

# Orofacial Function: Clinical Research in Dentistry and Speech Pathology

Proceedings of the Conference

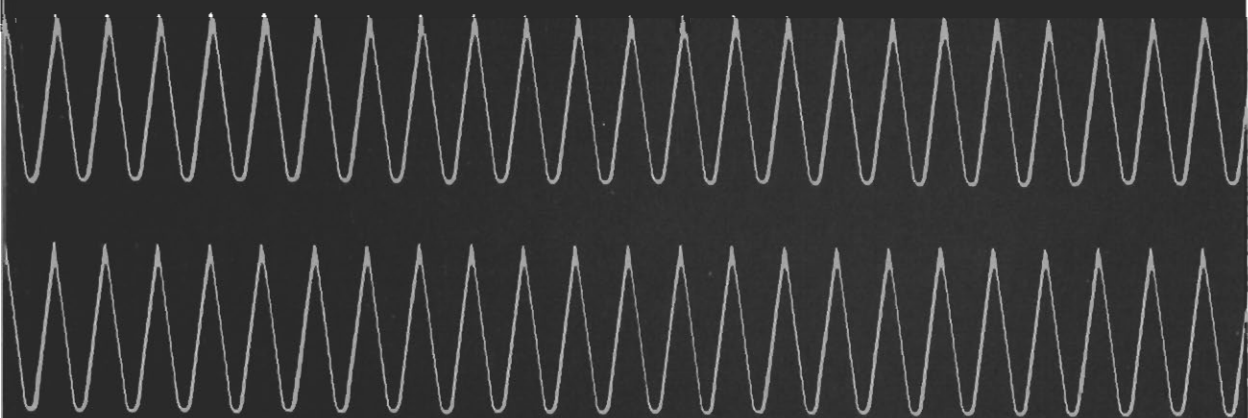

**ASHA** **REPORTS**

**NUMBER 7** A PUBLICATION OF THE AMERICAN SPEECH AND HEARING ASSOCIATION

PROCEEDINGS OF THE CONFERENCE  
OROFACIAL FUNCTION:  
CLINICAL RESEARCH IN DENTISTRY AND  
SPEECH PATHOLOGY

**This Conference was supported in part by  
NIH Training Grant DE 210-04  
National Institute of Dental Research  
U.S. Department of Health, Education, and Welfare**

Proceedings of the Conference

Orofacial Function:  
Clinical Research in Dentistry  
and Speech Pathology

Ann Arbor, Michigan  
March 1-3, 1971

*ASHA Reports 7*  
AMERICAN SPEECH AND HEARING ASSOCIATION  
Washington  
July 1972



A CONFERENCE ON  
OROFACIAL FUNCTION: CLINICAL RESEARCH  
IN DENTISTRY AND SPEECH PATHOLOGY

PLANNING COMMITTEE

Hughlett L. Morris, Ph.D.  
Sidney I. Silverman, D.D.S.  
Gary Smiley, D.D.S.  
Richard M. Cole, Ph.D., *Chairman*

JOINT COMMITTEE ON DENTISTRY AND  
SPEECH PATHOLOGY-AUDIOLOGY

Richard M. Cole, Ph.D.  
Sidney I. Silverman, D.D.S.  
Duane C. Spriestersbach, Ph.D.  
Raymond H. Steinacher, D.D.S.  
Donald W. Warren, D.D.S., Ph.D.  
H. Harlan Bloomer, Ph.D., *Chairman*  
James E. Fricke, Ph.D., *Executive Secretary*

ASHA REPORTS NUMBER 7

SERIES EDITOR

Robert T. Wertz, Ph.D.

REPORTS 7 EDITOR

Robert T. Wertz, Ph.D.

PROJECT DIRECTOR

Richard F. Curlee, Ph.D.

BUSINESS MANAGER

Kenneth O. Johnson, Ph.D.

PUBLICATIONS DEPARTMENT

Alfred K. Kawana, *Manager*  
Nancy Buell, *Editorial Assistant*

PUBLICATIONS BOARD

Frederic L. Darley, Ph.D., *Chairman*

Robert C. Bilger, Ph.D.

Margaret C. Byrne, Ph.D.

Elizabeth Carrow, Ph.D.

Katherine S. Harris, Ph.D.

William C. Healey, Ph.D.

Kenneth O. Johnson, Ph.D.

John P. Reneau, Ph.D.

Gerald M. Siegel, Ph.D.

Robert T. Wertz, Ph.D.

AMERICAN SPEECH AND HEARING ASSOCIATION

OFFICERS

*President*

Robert Goldstein, Ph.D.  
University of Wisconsin

*President-Elect*

Sylvia O. Richardson, M.D.  
University of Cincinnati College  
of Medicine

*Vice President for Administration*

Harold L. Luper, Ph.D.  
University of Tennessee

*Vice President for Education  
and Scientific Affairs*

Rolland J. Van Hattum, Ph.D.  
State University College at Buffalo

*Vice President for Standards and Ethics*

Frederick E. Garbee, M.Ed.  
California State Department of Education  
Los Angeles

*Vice President for Clinical Affairs*

Gerald G. Freeman, Ph.D.  
Oakland Schools Speech and Hearing Clinic  
Pontiac, Michigan

*Vice President for Planning*

Thelma Albritton, M.Ed.  
Eastern Michigan University

*Executive Secretary*

Kenneth O. Johnson, Ph.D.

## Contents

Preface	
<i>Joint Committee</i> .....	vii
Dental Maturation	
<i>Frederick M. Parkins</i> .....	1
Speech Maturation	
<i>Frederic K. W. Curry</i> .....	11
Changes in Communication Associated with Aging	
<i>Gerald J. Canter</i> .....	26
Degeneration of Dental and Orofacial Structures	
<i>Sidney I. Silverman</i> .....	33
Some New Techniques for Measuring the Biomechanical Events of Speech Production: One Laboratory's Experiences	
<i>Thomas J. Hixon</i> .....	68
Jaw Motion During Speech	
<i>Charles H. Gibbs and Theodore Messerman</i> .....	104
Speech Measures of Orofacial Function	
<i>Frank R. Kleffner</i> .....	113
Case Presentation and Discussion	
<i>H. Harlan Bloomer</i> .....	126
Collaborative Research Between Dentistry and Speech Pathology/Audiology	
<i>Richard M. Cole</i> .....	129
Summary Remarks	
<i>D. C. Priestersbach</i> .....	142
Conference Attendants .....	144



## PREFACE

Recognition of the rather sizable and potentially significant interface between the fields of dentistry and speech pathology-audiology prompted the American Association of Dental Schools and the American Speech and Hearing Association, with financial support from the National Institute of Dental Research, to establish a joint committee to investigate the nature and scope of this interface in service, training, and research.

The Joint Committee on Dentistry and Speech Pathology-Audiology, established in 1966 and consisting of three members from each parent organization, has (1) published articles of interest to the two fields; (2) presented programs at the annual conventions of the American Association of Dental Schools, the American Speech and Hearing Association, the American Cleft Palate Association, and other organizations; (3) conducted regional meetings of the deans of dental schools and heads of training programs in speech pathology and audiology; (4) surveyed by questionnaire the doctoral training programs in speech pathology and dental schools of this country regarding the nature and extent of the interaction between the two professions within their own institutions; (5) assisted in the placement of speech pathologists and audiologists in schools of dentistry; (6) created promotional materials which have demonstrated and advanced the philosophies of the Joint Committee; and (7) sponsored a series of three national conferences for identifying and evaluating the clinical and research contributions of mutual value to each profession, and delineating research frontiers of mutual concern to the two professional areas.

In planning the structure of the three annual conferences, the Joint Committee originally intended that each conference bring together 20 representatives from dental schools and 20 representatives from Ph.D. training programs in speech pathology and audiology, to provide them with current, complete information in specific areas of interest to both professions. Conference attendees were encouraged to engage in active discussion in each of the formal presentations. The first in the series of three conferences sponsored by the Joint Committee, entitled "Patterns of Orofacial Growth and Development," was held in March 1970 in Ann Arbor, Michigan. The proceedings of this conference were published in *ASHA Reports Number 6*. The discussion material was omitted from the conference proceedings and only the formal papers were presented in that publication. The proceedings of the second annual conference constitute the material for *ASHA Reports Number 7*.

The second annual conference and the present resulting publication represent several modifications of the planning which determined the format of the first conference and the ensuing publication. Greater attention was paid to audience selection, with an aim for achieving a better balance among re-

searchers, clinicians, and educators in each of the two professional areas. The program format was altered to provide relatively lengthy discussion periods, and a portion of the program was devoted to informal colloquium groups among the conference attendees.

The published proceedings of these annual conferences represent at least a partial realization of several of the primary goals of the Joint Committee: the development of widespread awareness of the mutually valuable clinical and research contributions of each profession; the exchange of current information between the two professions, with particular regard to research; and the education, orientation, and creation of researchers in each profession to undertake cooperative research with members of the other profession.

JOINT COMMITTEE (1971)  
*H. Harlan Bloomer, Ph.D., Chairman*  
*Richard M. Cole, Ph.D.*  
*Sidney Silverman, D.D.S.*  
*D. C. Priestersbach, Ph.D.*  
*Raymond H. Steinacher, D.D.S.*  
*Donald Warren, D.D.S., Ph.D.*  
*James E. Fricke, Ph.D.,*  
*Executive Secretary, JCDSP-A*

# DENTAL MATURATION

FREDERICK M. PARKINS

*University of Iowa, Iowa City, Iowa*

During the time the abilities of speech are being perfected, the dimensions and many of the components of the oral cavity are undergoing change. The nature of these changes and their effects on speech are of vital concern to the speech scientist and the dentist. This publication includes reports from a group of imminent investigators working on different aspects of the subject; therefore, I shall not attempt an academic *tour de force*. My presentation is designed to relate the maturation of a functional dentition as a series of working concepts the dental clinician uses in his treatment of children.

At birth the primitive maxilla and mandible house all 20 primary teeth and the crypts of the earlier erupting members of the permanent dentition. The infant has a relatively well-developed cranium. The lower face, like the rest of the body, is far less mature. Articulated, but underdeveloped, bony structures are seen.

We are fortunate that in the 1930s a dentist in England, Lilah Clinch (1934), had what one of her presentation's discussants described as the "pluck" to examine 500 newborn infants and to obtain a pair of intraoral impressions on 70 of them. She demonstrated the presence of "gum pads" along the maxillary and mandibular alveolar ridges. The ridges were somewhat segmented into individual prominences resembling in position the sites of the eruption of the primary teeth. On closure the pads met to form a primitive bite relationship, which varied among the infants because of their different states of mandibular development. The mandibular alveolar ridge was slightly lingual to the maxillary ridge in the incisor and molar regions in 70% of the cases. The mandibular ridge of the remaining infants was slightly lingual and distal to the maxillary ridge in the molar region, and definitely distal in the incisor region, with a few displaying a distal relationship along the entire perimeter. She was unable to find one case of mandibular protrusion among the entire 500 children examined.

To observe the effects of the erupting primary teeth, Clinch followed the children on whom she had obtained impressions, through their first two years. She found that the molar segments of the gum pads remained in contact, or occlusion, on closure. This posterior support created a space for the incisor teeth, the first to erupt. As the incisors neared full eruption, the respective

downward and upward growth of the maxillary and mandibular molar segments maintained the space. In this manner, the incisor eruption was accommodated without the soft tissue trauma seen with the occasional presence of an erupted tooth at birth.

At this point it is appropriate to consider the process of tooth formation. Teeth are among the few mineralized structures which do not undergo a continuous constituent replacement and structural remodeling. The usual alternating osteoclastic and osteoblastic activities do not affect them. The periodontal membrane normally isolates even the root structure from this process. Consequently, the events of formation and disease are relatively irreversible. Imperfectly formed teeth frequently bear a permanent blueprint for the timing of the disturbance during tooth formation which caused the defect. Schour and Massler (1941), in the early 1940s, developed a schematic description for the life cycle of the typical tooth. To this they added the more common aberrations in tooth development during the different categories of this life cycle (Schour and Massler, 1964). The life cycle of the tooth is presented in Figure 1, and the aberrations in tooth development are presented in Table 1. More recently, Kraus and Jordan (1965) have refined the description of tooth formation. Over a period of 15 years they intensively studied the morphology of the primary teeth and the permanent incisor and first molar teeth of human embryos. Their monograph of the "Human Dentition Before Birth" completely describes the maturation of each of these teeth up to the time of birth.

From approximately six months to the third year of life, the primary teeth erupt in an anterior to posterior sequence. The mechanism of tooth eruption is still not fully understood. The source of the outward force and the parting of the mucosa require investigation. Added to this enigma is the frequent systemic disturbance observed during the critical phase of tooth emergence. The brief period of fever, malaise, and irritability may possibly be associated with a bacterial infection of the eruption site. More likely, however, the symptoms relate directly to the eruption process itself.

The embryology of the periodontal structures has been more difficult to investigate. Individuals suffering from ectodermal dysplasia show that alveolar bone forms only in response to the presence of teeth. Teeth are embryologically derived from ectodermal tissue and are commonly absent in this disease. The bodies of the maxillary and mandibular bones grow to the usual adult dimensions. The deposition of bone to form the alveolar ridges, however, is almost completely absent. The alveolar bone also disappears after full mouth extraction. In contrast to the teeth, which undergo no routine changes, the alveolar bone is among the body's most labile and metabolically active mineralized tissue. It is of particular interest to note that with the exfoliation of a primary tooth, the bone and soft tissue associated with it are completely replaced. The permanent tooth is surrounded by newly formed alveolar bone, periodontal membrane, and fibrous attachment.

Because teeth form in an orderly sequence over many years, they afford a convenient opportunity to identify the state of an individual's maturation.

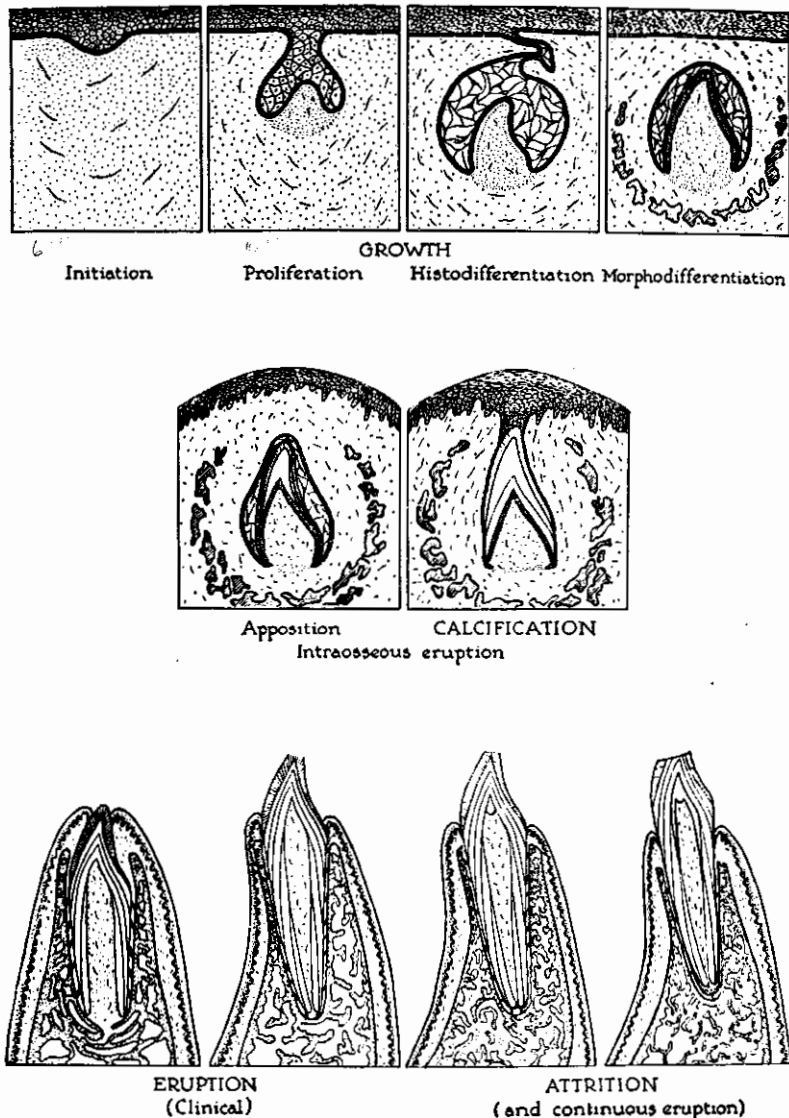

FIGURE 1. The life cycle of the tooth. (From Massler and Schour, 1958.)

The degrees of calcification, eruption, and root formation of the teeth can be used as milestones for facial growth and development. Frequent discrepancies are observed between chronologic age and the maturational stage of the face and dentition. Dental radiographs are used to identify a "dental age" for each patient. The situation is comparable to noting the development of ossicles in the wrist and has a greater relevance to events in the oral cavity.

The growth of the lower face, namely the nasomaxillary and mandibular



TABLE 1. Classifications of aberrations in tooth development. (From Schour and Massler, 1964.)

Character of Disturbance	Growth						Attrition	
	Initiation	Proliferation	Histodifferentiation	Morphodifferentiation	Apposition	Calcification		Eruption
	Abnormal Number	Atypical Structure	Atypical Structure	Atypical Forms and Sizes	Abnormal Amount	Abnormal Hardness	Abnormal Eruption	
Deficient Development	Anodontia—partial or complete	Amelogenesis imperfecta (ameloblasts)	Peg teeth	Hutchinson's incisor	Hypoplasias—systemic or local	Hypocalcification	Delayed eruption of teeth, single or multiple	Deficient wear
	Congenital absence of lateral incisors, third molars, bicuspid, etc.	Dentinogenesis imperfecta (odontoblasts)	Mulberry molars	Microdontia	Chronologic enamel hypoplasia	Mottled (chalky) enamel	Submerged denture	Restricted lateral excursion
Excessive Development		Vitamin A deficiency (odontogenic epithelium)	Extra cusps and roots	Dens in dente	Localized enamel pits	Malacotic enamel	Submerged teeth (ankylosis)	
			Macrodontia	Supernumerary teeth	Dentin hypoplasia (pulpal inclusions)	Interglobular dentin	Malposed teeth	
	Epithelial Rests	Odontogenic epithelium	Odontomes	Enamel nodules	Sclerotic dentin resulting from age, injury, or caries	Malocclusions	Excessive wear	Excessive wear
				Simple, compound, and complex odontomes		Excessive mesial and occlusal drift of teeth	Night grinding (bruxism)	
				Adamantinomas		Supraocclusion of teeth		
				Odontocoeles				

structures, is on a different time table from that of the cranial structures. The growth rates of all the components of the body have been divided into four categories: lymphoid, neural, general, and genital types. While the skull and basal structures associated with the upper face, including the orbit, form in accordance with the neural type of rate, the lower face most closely matches the general rate. The rate of maturation of teeth loosely compares with the rate of general systemic growth. The matching of an individual's height and weight to growth norms for his age, even when body type is considered, does not reveal the progress that particular individual has made toward his own mature dimensions. Therefore, the complete significance of "dental age" as a determinant of physiologic age is not clear. The possibility exists that this may be as accurate as the interpretations from wrist radiographs (Lamons and Gray, 1958).

Whether for genetic, endocrine, or other causes, discrepancies of plus or minus two to three years are commonly seen when an individual's dental maturation is compared to the norms given on standard charts and tables. Such a finding does not in itself indicate the presence of pathology. Youngsters demonstrating such discrepancies may be completely normal. By contrast, normal dental development is often seen in individuals suffering from physical and mental difficulties. For example, certain persons with cerebral palsy demonstrate a normal rate of dental maturation, although in other areas their maturation may be affected by congenital or developmental deformities. In many forms of mental retardation a patient also has dentition appropriate to his chronological age while his intellectual development is more typical of younger age groups.

At the time of birth the maxilla and mandible are too small to house a fully developed dentition. A similar statement holds for maxillary and mandibular size at the time the primary dentition is complete. Additional space is necessary for the second and third molar teeth.

The relative positions of upper and lower teeth on closure, the position I will refer to as "in occlusion," are dependent on the relative sizes and positions of the bones that contain them. Reference will be made to the alveolar bone as the natural denture base. The maxilla and the mandible grow downward and forward. Since this growth lags behind that of the cranium and its base, the concept has been adopted that these bones are growing downward and forward from the cranial base. The growth rate of these two bones must be synchronous or abnormal relationships between opposing teeth in the occlusal position will result.

Since the concepts of facial growth are fairly well known, I will touch only on key points for definition and review. The maxilla is separated from its cranial base by four pairs of sutures oriented in parallel. Their position at right angles to the normal direction of maxillary growth has made it attractive to consider pressures from growth within them as responsible for the linear movements. Recent evidence (Moss and Salentijn, 1969) suggests that sutural growth responds instead to a negative pressure produced by growth elsewhere. The

nasal septum and the resultant forces of muscular activity are presently credited with stimulating proliferation at the suture sites. For the purposes of this presentation, it is adequate to recognize the resultant downward and forward growth.

The mandible grows downward and forward principally through the growth centers in the condyles. Their proliferation appropriately propels the mandible away from its articulation with the temporal bone in the glenoid fossa. At the same time extensive remodeling of the mandibular ramus occurs. The coronoid process develops along the temporal muscle insertion. The entire anterior section of the ramus undergoes resorption while there is concomitant deposition along the entire distal border. In effect, a distal displacement of the entire ramus takes place. At the same time, adsorptive bone growth produces increasingly more mature contours along the periphery of the body of the mandible. By the second year the symphysis at the mandibular midline has closed, terminating the capacity for linear growth of the anterior portion of the mandible.

Instead of completely discussing the different mechanisms for bone growth, it should be sufficient to recall that the pacemakers for various components of maxillary and mandibular growth are believed to be somewhat dissimilar. Asynchrony in their growth rates can lead to undesirable relationships (1) of the two jaws to each other, (2) of one or both jaws to the cranial base, and (3) of the maxillary teeth to the mandibular teeth. It is of particular interest that a display of disharmony in their growth during the complete primary dentition stage is considered definitive evidence that the disharmony will persist and frequently become more severe. Techniques of "dentofacial orthopedics" which may suitably redirect asynchronous facial growth are presently being studied (Graber, 1969).

It is now pertinent to examine the primary dentition and discuss its characteristics. The individual primary teeth are smaller, except for a couple of dimensional discrepancies, than the permanent teeth which succeed them. Their pulp chambers are proportionately larger, and tend to follow their external contour more closely. The degree of mineralization appears somewhat less, and it has long been a clinical impression that the primary teeth are less sensitive to manipulative procedures. The term "milk teeth" has been applied because of their whiter coloration. This is especially true when they are compared with newly erupted permanent anterior teeth.

The alignment of the primary teeth is also unique. The plane established by their occlusal surfaces tends to be flat instead of resembling a segment of a sphere, as is the case with permanent teeth. The long axes of the primary teeth tend to be perpendicular to the occlusal plane. Their cusp height is less, reducing the amount of interdigitation between opposing teeth on closure. Attrition of the occlusal surfaces is common, further reducing the degree of interdigitation. The result is frequently the meeting of two flat surface areas on closure with little restriction imposed on mandibular movement. Because of the position and functional relationship of primary teeth, the tendency for

permanent teeth to migrate mesially does not appear until the first permanent molars erupt. Since the paths of eruption and the long axes of these first permanent molars are mesially inclined, they erupt against the distal surfaces of the second primary molars. This introduces a mesial component of force, which is augmented by the impact which occurs with their altered occlusal position. The positions of the first permanent molars also begin the warping of the occlusal plane toward its adult configuration.

The arc described by the alignment of the primary teeth along the denture base, commonly referred to as the "dental arch," follows a basically ovoid form. In the permanent dentition the buccal surfaces of the premolars and the first permanent molars are often distributed along a straight line. The permanent cuspid is located at a turning point producing a square arch form. The result of the primary dentition characteristics is an attractive, cherub-like appearance. This is the time to fill the family picture albums.

In addition to the physical characteristics, a chemical discrepancy must also exist. Children below the age of puberty seldom evidence calculus formation. The lack of calcified deposits on tooth surfaces, especially at the gingival margin, is in direct contrast to what is seen in the majority of adults. In adults, calculus formation is common and must be controlled for dental health. With rare exception, the appearance of calculus is first observed about the time of puberty. A more exact correlation between this obvious chemical change and the onset of puberty deserves future investigation.

On considering the locations of the maxillary and mandibular growth sites, it becomes obvious that the primary centers of linear change are not along the dental arches in positions mesial to the first permanent molars. Distal migration of the mandibular ramus and deposition of bone at the site of the maxillary tuberosities produce the additional alveolar length required for the eruption of the permanent molars. The broadening of the overall arch width is achieved primarily by the divergence of the distally forming posterior segments. Measurements of arch width increases between tooth pairs have shown only small increases in the order of two to five millimeters. Although the alveolar ridges are increasing in height, the length of their perimeter from first molar to first molar, commonly referred to as "arch length," is almost constant. Due to the concept of relatively consistent arch lengths, there is great clinical interest in the measure and conservation of arch lengths. The concern is greatly increased with the introduction of the mesial component of force brought about by the eruption of the first permanent molars. The placement of space maintainers to preserve the mesial distal dimension of the lost primary tooth, to accommodate the erupting permanent tooth, is considered essential in most cases.

The genetic coding for permanent tooth size is relatively consistent. Simply stated, if the early erupting permanent teeth are larger or smaller than their normal dimensions, the other permanent teeth can be expected to have similarly larger or smaller than normal dimensions. This observation is used extensively to judge the space which will be needed for permanent teeth which are not

yet erupted. The estimates are compared with measurements of the actual amount of space in the mouth. Such procedures have been categorized as "arch length analyses."

In addition to allowing us to perform arch length analyses, the eruption of the permanent anterior teeth involves other considerations. The exact sequence for exfoliation and eruption of the four incisors is highly variable. Whether the mandibular central incisors are followed by mandibular lateral incisors or maxillary central incisors is probably of little consequence. In certain instances, however, local conditions result in retarded eruption, especially of lateral incisors, or premature exfoliation of primary cuspids as the result of root resorptive effects by erupting lateral incisors. Of similar nature are clinical considerations associated with the early loss of primary incisors. It is frequently considered a disadvantage for a youngster to lose primary incisors before his peer group is undergoing a similar experience. The early existence of anterior spaces has led to concern about the development of noxious tongue habits, psychological trauma, and disturbances in the development of normal speech (Lindahl, 1961). These are primarily empirical considerations which require investigation for confirmation. Because primary anterior teeth frequently have spaces between them, and these spaces remain constant due to the lack of any growth potential in that area, the need for space maintenance is considered secondary. The question concerning the need for prosthetic replacement of the prematurely lost anterior teeth requires resolution.

The position of permanent anterior teeth as they erupt warrants discussion. The mandibular incisors enter in a position lingual to the primary incisors. If the primary incisors are not exfoliated at the time of eruption, difficulties ensue. Maxillary incisors may be displaced lingually and produce a cross-bite. Mandibular incisors may become severely jumbled. After their eruption, tongue pressure pushes these teeth forward into alignment. The theory has been held that these teeth move to a position of equilibrium between the muscle forces of the lip and tongue. Analyses of these forces with strain gage transducers have not confirmed this theory (Proffit, Chastain, and Norton, 1969). Further investigation of the forces which result in permanent anterior tooth placement is required. If space is sufficient, all four permanent anterior teeth in the mandible will be moved into normal alignment. A minor space discrepancy frequently exists which is resolved by the eruption of other permanent teeth later. As a result, a period of mild jumbling of lower incisors is common.

The maxillary incisors erupt at divergent angles. The long axes tend to meet at a point high in the nasal region. The resulting diastema and odd crown position frequently create parental alarm. On occasion, this leads to a resection of the labial frenum. The natural resolution of the situation is commonly brought about by the eruption force of the permanent cuspids. Since the permanent cuspid is the last tooth in the maxillary arch to succeed a primary tooth, a delay of several years ensues between incisor eruption and cuspid eruption. During this delay, parental anxiety frequently leads to unnecessary

freneotomies. It is recommended that such procedures be delayed until after the eruption of the permanent cuspids.

The primary teeth are smaller overall than their permanent successors. Analysis of individual dimensions, however, brings up a notable exception between the primary molars and their succeeding permanent bicuspid. The larger mesial-distal widths of the primary molars have led to the concept of "leeway space." This highly variable dimension, averaging 0.9 mm in the maxilla and 1.7 mm in the mandible, has been given extensive clinical consideration. One reason for this interest is the occlusal relationship seen most commonly between the erupted first permanent molars. Before the loss of the primary molars, the first permanent molars tend to be directly opposed, with their cusp tips in contact. This occurs because the distal surfaces of opposing second primary molars lie in a straight line. The normal relationship between first permanent molars can then only be established by the eruption of the mesial-distally smaller permanent premolars. Because a greater leeway space exists in the mandibular arch, the mandibular first permanent molar, responding to its mesial component of force, moves farther forward than does the maxillary counterpart. As a result, the mesial cusp of the maxillary first permanent molar meets the central fossa of the mandibular first permanent molar. This "mesial step" position constitutes the normal molar occlusal relationship.

The same mandibular leeway space is also considered useful for the space allowance required for proper alignment of the lower anterior teeth. In individual clinical cases, the resolution of both of these problems is subject to great variation.

An additional complication results when the normal sequence of eruption does not occur. The sequence which is particularly disturbing involves the eruption of the second permanent molars before the eruption of the second bicuspid. The increased mesial component of force derived from the eruption of the second permanent molars may reduce the space available for the second bicuspid during the brief period between exfoliation of the second primary molar and its eruption.

When all events occur ideally, the result is a functionally and esthetically beautiful dentition. Far too often, however, the outcome leaves much to be desired. In today's social climate it is imperative to know more about the significance of each of the deviations and to mobilize resources to cure the ones which will cause significant problems.

#### REFERENCES

- CLINCH, LILAH, Variations in the mutual relationships of the maxillary and mandibular gum pads in the newborn child. *Int. J. Orthodont. D.C.*, 20, 359-372 (1934).  
GRABER, T. M., Dentofacial orthopedics. *Current Orthodontic Concepts and Techniques*. Philadelphia: Saunders, 919-988 (1969).  
KRAUS, S., and JORDAN, R. E., *The Human Dentition Before Birth*. Philadelphia: Lea and Feibiger (1965).  
LAMONS, F. F., and GRAY, S. W., A study of the relationship between tooth eruption age,

- skeletal developmental age, and chronological age. *Amer. J. Orthodont.*, 44, 687-691 (1958).
- LINDAHL, R. L., Denture techniques suitable for growing arches. *Dent. Clin. N. Amer.*, 649-660 (Nov. 1961).
- MASSLER, M., and SCHOUR, I., Plates 7 and 8 in *Atlas of the Mouth*. (2nd ed.) Chicago: Amer. Dent. Ass. (1958).
- MOSS, M. L., and SALENTIJN, L., The primary role of functional matrices in facial growth. *Amer. J. Orthodont.*, 55, 566-577 (1969).
- PROFFIT, W. R., CHASTAIN, B. B., and NORTON, L. A., Linguopalatal pressure in children. *Amer. J. Orthodont.*, 55, 154-166 (1969).
- SCHOUR, I., and MASSLER, M., The development of the human dentition. *J. Amer. dent. Ass.*, 28, 1153-1160 (1941).

## SPEECH MATURATION

FREDERIC K. W. CURRY

*Siegel Institute for Communicative Disorders  
Michael Reese Hospital and Medical Center, Chicago, Illinois*

There are thousands of babies being born throughout the world at this very moment, uttering their first birth cries, who in the next 48 months will master something to an extent that most of us could not equal in the rest of our lifetimes. I refer, of course, to the mastering of a spoken language never heard before. For most of us, despite our education, degrees, fancy titles, and various sophistications, learning to speak a language we have never heard before would constitute an Herculean task, with or without formal instruction. Those of us who succeeded in reaching a level where we could converse spontaneously with a native speaker would continually betray our "foreignness" through mispronunciation, inaccurate stress and intonational patterns, errors of grammar and word order, and limited vocabulary. In contrast, our 7½-pound, 20-inch competitors will have achieved a high level of mastery of the spoken language of their parents in only four short years, and that with apparently effortless learning and without formal instruction. At that time they too will have problems making some of the speech sounds and getting the correct grammatical constructions, but they will be able to express themselves and be understood. Their vocabularies, however, will be ample and expand with little effort as their experiences and interests widen and as their cognitive development proceeds. Although the newborn infants of today will not have totally mastered the spoken language of their parents four years hence, they will have so mastered the code that no native speaker of the language would view them as being "foreigners." Furthermore, they will be able to generate utterances in the spoken language code which they have never heard spoken before. They will be originators of uniquely verbalized thoughts and ideas, not mere talking machines parroting back what others have said to them. It is the emergence of this uniquely human attribute of verbal communication which we are considering here, going from the neonatal state when speech is neither understood nor produced to that point in later childhood when linguistic competency is variously demonstrated through the child's capacity to understand the speech of others and to generate speech productions which are in turn meaningful to listeners.



## THE NATURE OF THE SPEECH ACQUISITION TASK

As a background to the topic of speech maturation it is of value to consider the nature of that which is being acquired, namely spoken language. Language may be broadly defined as a system of symbols which have arbitrarily assigned meanings used by a community for purposes of communication. Such a broad definition would include symbol systems employing a variety of transmission modes, the most common of which would be the spoken and written languages. Other transmission modes can and do exist, such as the manual-visual sign language system used by the deaf community. This discussion, however, will be limited to the spoken language system where the transmission mode is vocal-auditory. Let us first look briefly at the nature of the sound generator in this system.

### *The Speech-Sound Mechanism*

The speech-sound-generating mechanism of the human involves the respiratory and upper digestive tracts. Figure 1 shows a schematic view of a portion of this mechanism. In the broadest of terms, the system consists of a series of cavities which can be shaped and coupled to varying degrees. The cavities are the pharyngeal, the oral, and nasal cavities. The nasal cavity will or will not be coupled to the vocal tract system, depending on the activity of the velopharyngeal sphincter. The size and shape of the oral cavity are highly variable, depending on the positioning of the tongue, the lips, and the jaw. The pharyngeal cavity is also subject to some variation in shape. Varying the vocal tract configuration in relation to sound production is the process called *articulation*.

The source of energy for the production of speech sounds is the steady breathstream we exhale from the lungs. If this breathstream is set into rapid vibration, an audible sound will be produced. The nature of this sound will depend on such things as what causes the breathstream to vibrate; the size, shape, and coupling of the cavities; and the nature of the openings out of the cavities.

There are essentially three ways of producing the rapid vibrations of the breathstream to make speech sounds (Denes and Pinson, 1963). In the first way the vocal cords interrupt the breathstream at the level of the larynx. The vocal cords form a valve at the top of the trachea leading to and from the lungs. When the vocal cords are open, the airstream moves freely through. If the valve is closed, the pressure of the breathstream below the vocal cords will cause them to vibrate. As they vibrate, the breathstream moves into the vocal tract in a series of puffs, corresponding to the opening and closing of the cords. This will be heard as a buzzing tone. The vocal tract, which acts as a resonator, will further modify the character of this tone. As the shape of the resonator is changed, so will be the nature of the tone. A speech sound produced in this manner, with vocal cord vibration, is said to be a *voiced* sound.

The second way of causing breathstream vibration is by forming a constriction at some point in the vocal tract. As the breathstream is forced out

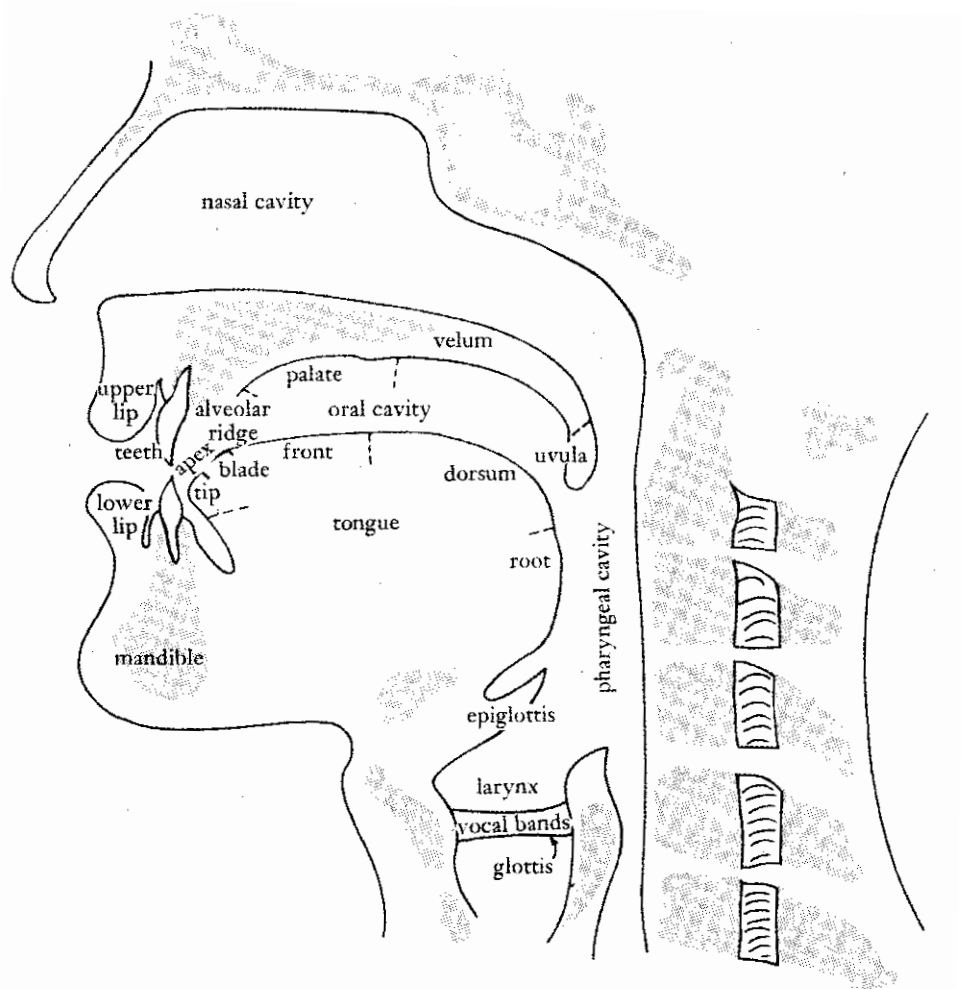

FIGURE 1. The speech-sound-generating mechanism. (From Francis, 1958, as cited in Brown, 1965.)

through the constriction, turbulence is created, producing a hissing sound such as /s/ or /ʃ/. Such sounds are called *fricatives*.

The third way of producing sound is to momentarily stop the flow of the breathstream by blocking it at some point in the vocal tract, such as at the lips. The air pressure built up behind that blockage is suddenly released, producing the sound, such as /p/. The sounds are called *plosives*. Sounds may be produced by using either a constriction or blockage of the vocal tract in simultaneous conjunction with vocal cord vibration, as in /b/ or /z/.

### *Structural Aspects of Spoken Language*

All spoken languages have certain structural similarities in common (Brown,

1965, p. 248). These include a finite set of sound categories, a set of meaningful units made up of combinations of these sound categories, and a set of rules for combining the meaningful units.

The first feature, the set of sound categories, constitutes the phonological system of the spoken language. Every language has a finite number of sounds its speakers use to produce all of the meaningful utterances in that language. Languages throughout the world vary considerably in the number and kinds of sounds they employ in their phonological systems. English uses approximately 40-45 sound categories, whereas other languages have from 15 to 85 (Brown, 1965, p. 247).

English speech sounds can be broadly classified into two groups, vowels and consonants. The vowel sounds are complex musical tones which are produced by vocal fold vibration and vocal tract resonance. A speaker of English will use approximately 14 vowel sounds. For the production of the range of these vowels, the resonance characteristics of the oral cavity are changed by varying configurations of the tongue and lips. Vowels are frequently described in physiological terms, by indicating the portion of the tongue acting as a mobile articulator, and the height of the tongue. Thus a vowel such as /i/, as in *heat*, would be called a high-front vowel because the front of the tongue is held close to the palate. The vowel /ɑ/ as in *father*, is a low-back vowel. A description of the lip configuration is sometimes also included in vowel descriptions.

The other broad grouping of sounds is the consonants. These are sounds which have greater noise components and which are produced by momentarily stopping the breathstream in the vocal tract, or constricting or diverting it. Consonant sounds may or may not be voiced. The physiological description of consonant sounds usually involves three dimensions—voicing, place of articulation, and mode of articulation. Place of articulation refers to the point of stopping or constriction. The common designations of place are labial, labio-dental, dental, alveolar, palatal, velar, and glottal. The mode of articulation describes the nature of the breathstream interruption. Common modes are plosive, fricative, affricative, nasal, and semivowel (glides). Table 1 summarizes some of the English consonants.

TABLE 1. Classification of English consonants. -V = voiceless; +V = voiced.

Place of Articulation	Mode of Articulation									
	Plosive		Fricative		Affricative		Semivowel		Nasal	
	-V	+V	-V	+V	-V	+V	-V	+V	-V	+V
Labial	p	b	-	-	-	-	-	w	-	m
Labial-Dental	-	-	f	v	-	-	-	-	-	-
Dental	-	-	th	th	-	-	-	-	-	-
Alveolar	t	d	s	z	-	-	-	y, l, r	-	n
Palatal	-	-	sh	zh	ch	j	-	-	-	-
Velar	k	g	-	-	-	-	-	-	-	ng
Glottal	-	-	h	-	-	-	-	-	-	-

The sound categories making up the phonological system of any spoken language are called *phonemes*.

A phoneme is not a single sound, but rather a group or range of sounds which the speakers of a common language treat as though they were identical (Carroll, 1964, p. 13). All of the sounds within a given category of phonemes will be heard as belonging to the same family even though there may be discernible acoustic differences among the individual sounds. For example, the final sound in the word *cat* can be made with an audible, "aspirated" release of the air pressure built up behind the tongue, or it can be made with a silent, "unaspirated" release. In both instances the listener will perceive the final sound as belonging to the /t/ category, ignoring the obvious acoustical difference, or perhaps even being totally unaware of the acoustical difference until it is pointed out. In every phonemic category in every language there are numerous sounds, and these sounds will all differ to some degree in their acoustic features or the way they are formed by the speech mechanism. These differences may result from (1) the improbability of a given speaker producing the same sound in an identical fashion on subsequent occasions, (2) differences arising when different speakers attempt to produce the same sound, and (3) differences which arise out of the speech-sound context in which they occur. An example of this latter difference is the tendency for English speakers to change the duration of a vowel sound, depending on whether or not the following consonant is made with the vocal cords vibrating. In the word pair *coat-code* one can easily hear that the /o/ is longer in *code* where it is followed by the /d/, which requires vocal cord vibration. This difference in duration, while discernible, is not critical to the listener's perception, and so the two sounds are judged to belong to the same phonemic family.

The corollary to the foregoing discussion is the concept that all of the sounds judged to belong to the same phonemic family share certain common attributes called *distinctive features*. Any sound not having all of the distinctive features of a particular phoneme will be perceived as belonging to a different phonemic category. Phonemes of a language will differ from one another by one or more distinctive features. For example, the phonemes /p/ and /b/ differ by only one distinctive feature, that of voicing (presence or absence of vocal cord vibration). Distinctive features defining the sounds of one language may vary from those of another language. For example, duration of a sound may be a critical variable in a language, so that two sounds that are identical except for length of utterance may be perceived by listeners as belonging to different phonemes. This does not happen to be the case in English, where we saw in the example of the word pair *coat-code* that the vowels in both words were perceived as belonging to the /o/ phoneme, despite durational differences. The distinctive features which are perceptually important for English, or for any other language, are not fully identified, and much of the work in this area is largely theoretical (Jakobson, Fant, and Halle, 1963; Chomsky and Halle, 1968).

The phonemes discussed thus far are segments of sound which are com-

bined with other segments to form larger elements of speech. These individual phoneme segments carry no meaning in the sense that they refer to, or stand for, something. They are, however, considered to be the smallest elements of spoken language which, if changed, will affect what the listener perceives and possibly confuse or change the meaning of what he hears. Referring back to the example of the word *cat*, we see that the final /t/ phoneme might be rendered in several different ways and the word still would be perceived as *cat*. However, if the speaker alters one of the distinctive features of /t/ by making it voiced instead of voiceless (adding vocal fold vibration), then the listener perceives the phoneme /d/ instead of /t/. This changes the perceived word from *cat* to *cad*.

In addition to the system of phoneme segments, there are other kinds of phonemes in the phonology of any language. These generally are classified as stress, pitch, and juncture phonemes. Such phonemes are not segments of sound, but rather they occur simultaneously with the phoneme segments, or separate them (Carroll, 1964, p. 16). *Stress* refers to the relative degree of intensity with which a syllable is uttered; *pitch* refers to the relative height of the tone of a syllable and to the contour or intonational pattern; and *juncture* refers to pauses or transitions between speech segments. Every language has such phonemes (sometimes called *suprasegmental phonemes*) which can alter meaning, but the nature of these suprasegmental phonemes will also vary from language to language.

It has been proposed that a relatively small number of attributes or features underlie the phonology systems of all languages, and that these features reflect the innate capacity and characteristics of man's sound-producing mechanism and ability to perceive sound (Lieberman, 1967; Menyuk, 1968; Stampe, 1969). One aspect, then, of the speech acquisition task is to "crack" the phonological code of the language. Ultimately this means the capacity to perceive and generate the acoustic speech signals according to the phonological rules of the language.

Earlier I mentioned that spoken languages have three common features. The feature discussed thus far has been phonology or sound structure. The other two features common to all languages are a set of meaningful units and rules for combining these meaningful units into larger utterances. Linguists call the smallest meaningful units of a language its *morphemes*. A morpheme consists of a sequence of phonemes combined according to the phonological rules of the language. All morphemes have some semantic content. Some morphemes can stand by themselves as words, such as *dog* or *cat*. Such morphemes cannot be reduced to smaller semantic units. However, not all morphemes correspond to words. For example, the word *dogs* is made up of two morphemes, *dog* and *s* (actually /z/). The first morpheme, called a *free morpheme*, can stand alone, but the second must always be in combination with another morpheme and so is called a *bound morpheme*. Nevertheless, it still has semantic content denoting plurality. Words in English are either free morphemes or various combinations of morphemes, free or bound.

Morphemes can be combined with one another to form words and larger constructions which we would commonly call phrases and sentences. Every language has a grammatical structure consisting of rules governing the building of words (morphology) and the building of sentences (syntax). It is this latter feature, the rules for building sentences, which permits an almost infinite number of utterances to be generated in a language.

Mastery of a spoken language by a child, then, will entail not only the cracking of the phonological code, but also learning to recognize and produce the morphemes of the language (a never-ending process), as well as developing competency in applying grammatical rules to understand and produce spoken language.

The discussion of spoken language thus far has dealt in broad terms with the structure of language, with little reference to meaning. Structure of language at the level of morphology and syntax is intimately related to meaning, but structure can exist independent of meaning, as illustrated by such non-sense verse as Lewis Carroll's:

'Twas brillig and the slithy tove  
Did gyre and gimble in the wabe . . .

(Also see Berko, 1958). Our language competency tells us that we are hearing correct English and we can almost "taste" the meaning, but it is hollow form. Meanings of morphemes are essentially arbitrary. There is usually no innate relationship between the meaning of a word and its referent. For the child learning a language, the meanings of the morphemes must be determined and memorized. It has been estimated that highly educated people may learn to recognize the meaning of 100,000 morphemes, but rarely produce more than one-tenth of these (Miller, 1951). Since the semantic content of a language reflects the cognitive operations of the speech community (and may also influence cognition as well—see Brown, 1958), the child must develop similar perceptual and cognitive organization of his world if he is to incorporate the word referents into his vocabulary. For the child, as well as for any speaker-listener, the meaningfulness of the infinite number of sentences heard will greatly depend on his knowledge of the meanings of the morphemes and his familiarity with the grammatical constructions and their meanings.

Mastery of a spoken language entails the development of a language competency which involves the establishment of certain cognitive categories and a "sense" of the underlying phonological and grammatical rules of a language which permit the individual to understand and generate utterances he has not previously heard. Although language competency is revealed through performance in talking or listening to speech, psycholinguists consider competency as being distinct from and underlying performance. Language performance, that is listening and speaking behavior, can be described, but if the regularities described are to be understood and explained, then it must be done with reference to the underlying language competency (McNeill, 1966).

### *Some Considerations About the Learner*

Thus far the discussion has been concerned primarily with aspects of the spoken language which are being acquired by the child. Let us now consider some aspects of the child who is the acquirer. The child acquiring language is a dynamic and changing organism. The period of life when language emerges is also the period when there is greatest physical maturation. The patterns, directions, and speed of all facets of development of the child are determined by the interaction between the innate, genetically endowed program and the environmental forces and influences. The nature and effects of this interaction will continually vary, depending upon the stage of maturation of the child.

The newborn child cannot be regarded as a miniature adult without speech, a *tabula rasa* onto which language will be imposed. Nor can he be considered nothing more than a helpless, hairless ape who will be different from the apes of the jungle only by virtue of his learning the language and social mores of the humans around him. If an infant could survive being reared by apes, he would be more than an ape, although without speech. Likewise an ape reared by humans will not attain the status of a human, nor learn language. The human infant is genetically endowed with the capacity to acquire spoken language (Lenneberg, 1967). This capacity gradually unfolds as the child matures. This maturation takes place in a linguistic environment, and at various stages in the unfolding process the child will respond to the linguistic environment in various ways. These responses show a degree of regularity from child to child, both in the order and in the time of emergence. This is true whether the spoken language of the environment is English, Russian, Chinese, or any other of the world's languages. A child acquires one language as easily as another. External influences cannot appreciably speed the maturation of a child's language acquisition system; they can, however, delay it. Furthermore, there is some evidence that there is a critical period early in life, possibly the prepubertal years, during which spoken language can most easily and spontaneously be acquired. Once this period is past, language learning or relearning becomes more laborious. This may well be related to man's pattern of neurophysiological development, going from a state of great plasticity and adaptability in infancy to one of increasing complexity and higher level of organization. The higher the level of organization, the lesser the adaptability.

The regularity in the development of spoken language from child to child among existing speech communities suggests that normal, healthy infants are endowed with similar predispositions to react to the world around them. The neurophysiological system places certain common constraints upon infants in sensory processing, integration, and motor output. Much human behavior has as its basis the development of hierarchies of categorization. For infants there may be certain natural tendencies, based upon neurophysiological constraints, to process and categorize sensory information in common ways. Just as a tuning fork has a natural frequency to which it will respond, the maturing infant may have the capacity to respond to certain contrasts contained in

incoming information. As the system matures, these contrasts will be elaborated and added to, and a hierarchy of superordinate-subordinate categories will be developed. Relating this to the perception of spoken language, certain aspects of the speech signal may be most easily distinguished early in infancy. Perhaps the grossest might be that which permits the infant to distinguish human speech sounds from the vast array of other sounds he hears. As the infant matures and the system permits, he gradually perceives stress and intonation patterns and the other acoustic features which form the distinctive attributes of speech. On the side of vocal output, the neurological-anatomical-physiological attributes of their sound-producing mechanisms impose similar constraints on all infants. They have an innate phonological capacity which will vary at different stages of development. For speech production this is intimately locked to sensory feedback mechanisms, particularly the auditory and tactile-kinesthetic mechanisms. Out of this natural, innate phonology emerges the phonology of the spoken language being learned through ordering, limiting, or suppressing certain innate phonological processes (Stampe, 1969).

Although the spoken languages of the world vary considerably in their structural attributes, they are, nevertheless, products of human beings. Many psycholinguists feel that there are universals which underlie all languages (Brown, 1965). The presence of these universals, the regularity and ordered emergence of speech, and the fact that any normal infant can learn any of the world's languages with apparently the same ease, suggest the intimate relationship between human genetic endowment and the learning of spoken language.

Having considered some aspects of spoken language structure and the child acquiring language, let us turn to a description of the emergence of spoken language.

#### EMERGENCE OF SPOKEN LANGUAGE

Taking a panoramic view of the emergence of spoken language, one sees a developmental process which ranges from a completely nonlinguistic state in infancy to a state of near linguistic mastery well before the first decade of life is completed. As one moves along the chronological age line, there are progressions from the involuntary to the voluntary, nondifferentiated to the differentiated, and nonpurposeful to the purposeful. One also sees a pattern of behavior indicating that auditory discrimination and comprehension precede spoken language production. Much of the study of the emergence of speech has dealt primarily with production. Relatively little is known about the developmental aspects of auditory reception and comprehension as well as the development of the coupling of production and reception through feedback mechanisms.

When the infant is born he is capable of responding to acoustic stimuli and producing sound. Actually, the capacity to respond to acoustic stimuli is developed well before birth, but it is not clear to what intensities and range of



frequencies the fetus can respond (Carmichael, 1954). The first sound production utilizing the vocal tract coupled with the respiratory system is the birth cry. This is a spontaneous reflexive sound which occurs in the first moments after birth when respiration is being established. It is the result of the passage of air activating the vocal cords and may occur on both inspiration and expiration. This represents the first time the infant hears his own voice.

The range and kinds of sounds the child produces during the very early weeks of life will be relatively independent of the speech stimulation provided by the environment. Even hearing children who are born to deaf parents (who cannot hear their children and who themselves produce deviant speech sounds) have been observed to make as much noise and go through the same sequence of vocalization at comparable ages as children with normally hearing parents (Lenneberg, 1967, p. 137). This is not meant to imply that early speech stimulation is unimportant, since it undoubtedly affects the nature of speech output at a later stage. The sounds infants make during these early months are primarily related to physiological states of comfort and discomfort. In the early weeks, crying and whimpering sounds associated with discomfort predominate, but gradually over the next several months, comfort sounds will begin to appear. An adult listener will perceive these early, comfort sounds as being predominantly vowel-like, similar to the vowels made toward the front of the oral cavity. Consonant-like sounds heard at this time, such as /k/ and glottal sounds such as /h/, tend to be produced toward the back of the oral cavity. By the time the child reaches his sixth month he will have produced most of the vowel elements and about half of the consonants. (See McCarthy, 1954, p. 509 and 510, for a summary of the studies by Irwin and Chen of early sound development.) Although the sounds the cooing infant produces at this time may be classifiable in terms of an adult listener's phonemic system, the sounds are not phonemic for the infant and not used linguistically. During these early months, hearing seems to play little part in the amount or kind of sound production. This is illustrated by the observation that until about the sixth month of life deaf children who are deprived of auditory feedback still produce sounds similar to those that hearing infants produce (Fry, 1966; Lenneberg, 1967, p. 139). Although the actual output seems little affected by the presense or absence of hearing in early life, it is quite probable that associations are beginning to be established in the child's brain between the sensory feedback systems of audition, touch, and kinesthesia, and the mechanisms of sound production.

The infant also is beginning response to events outside his body. At some time during his first two months, the infant seems to differentiate the sound of the human voice from other sounds and will attend and react positively (McCarthy, 1954). There is some recent evidence that infants as young as one month may be able to discriminate between certain acoustic cues which signal a phonemic difference for adults (Eimas et al., 1971). It would indeed be surprising if the child did not begin to attend to his auditory world and make auditory discriminations during these early months which will form the basis

of later phonemic categorization and speech comprehension and production.

Possibly beginning about the third or fourth months, but even more evident around the sixth month, is the gradual emergence of vocalization by the infant which seems to be related to his capacity to monitor himself, chiefly through hearing. This is the babbling stage, a period characterized by what has been called *vocal play*. During this stage there is an increase in the amount and variety of vocalization which seems to be related to self stimulation. During the babbling stage, at approximately six months, deaf infants begin to show differences from normals in their vocalizations. They may begin the babbling stage, but do not normally sustain it (Fry, 1966). Babbling occurs during comfort states and seems to be pleasurable for the child. Early in the babbling stage a sound produced by the child will evoke another sound. As the auditory-motor patterns are built up, sequences of the same and contrasting sounds will be made. During this vocal play a wide variety of sounds will be produced, far more than a child will ultimately need to learn the spoken language of his parents. Some observations suggest that early in the babbling period infants from varying language environments are not easily distinguishable, but as the babbling period goes on there is a drift toward the sounds, stress, and intonational patterns of the language of the parents. Such a drift can be detected as early as the sixth or seventh month (Weir, 1966). This drift obviously signals that the child is beginning to distinguish patterns and attributes of the language.

During this period the child has become much more of a social being. He will begin to signal emotions and needs vocally, and he will begin to respond to the speech of others with vocalizations. This gradually progresses to where there may be gross imitations or echoings of sounds, words, and inflected jargon. Signs of true comprehension also emerge around the ninth month. There will be differential responses to different intonational and stress patterns. A sharp "No" or "Bye-bye" will produce responses which show a degree of comprehension. At approximately 12 months the first meaningful word approximations will appear.

Much of the first year of life constitutes the prelinguistic stage of spoken language development. During the first half of the second year, prelinguistic behavior continues, in the form of continued vocal experimentation and jargon. The period from 12-18 months is not marked by great growth in spoken language production, although comprehension increases rapidly. The child will show understanding of simple commands, and will recognize many names of people and objects when named by others. By 18 months, his expressive vocabulary is usually still countable—perhaps 10 to 50 understandable words. He is not yet likely to combine words, but he will use a single word to express a whole idea. He will also produce completely unintelligible strings of jargon which may grossly adhere to the phonological rules of the language and have intonational and stress patterns which are linguistically appropriate, but which seem devoid of meaning. At this time he shows little frustration when not understood.

At some time around the twenty-fourth month the first productions showing syntactic development begin to appear in the form of simple, two-word phrases such as "More juice." Between this time and the age of three or four years, the child develops great verbal facility. Vocabulary, sentence-length, and sentence complexity all increase remarkably. A reflection of the child's language competency at the age of three years is that he will show all of the major parts of speech that an eight-year-old child will show, and in roughly the same proportion (Templin, 1957). The child of three or four will show many grammatical inaccuracies and still be producing many structurally incomplete sentences, but by then he will have abstracted major grammatical principles which underlie language comprehension and production.

Part of the developmental sequence in spoken language acquisition includes learning the phonological code. We can assume that when the child begins to respond differentially to spoken language sequences he is beginning to operate with the phonemic system of the language. This will eventually show itself expressively in successively closer approximations of correct speech-sound productions. Apparently the child does not learn the individual sounds of a language as isolated segments which he then combines into sequences to which are added meanings. Study of early speech development suggests that the child operates perceptually with larger segments and that part of the developmental process is the progressive discrimination of smaller segments. The learning of correct speech-sound production is thought to be understood best in relationship to the concept of distinctive features. In other words, instead of learning 45 different speech sounds as individual and completely distinct units, the English-speaking child learns a smaller number of distinctive features, which in various combinations will yield the speech sounds. The initial mastery of a few sounds, each consisting of a set of attributes, may provide a base from which all other sounds can be derived by various combinations of their distinctive features (Crocker, 1969).

Studies of the speech-sound development of American children show a process which is not completed until approximately the eighth year (Templin, 1957). There is substantial agreement that certain sounds are mastered earlier than others in the developmental period. In her study of 480 children, ages three to eight, Templin (1957) observed that vowel sounds seem to be learned earlier than consonants, and consonant blends, such as /st/ seem more difficult than single consonant units. Among various types of consonant sounds the ranking from most to least accurately produced seems to be nasals, plosives, semivowels, fricatives, and combinations. Considering specific consonant sounds, Templin found that 75% of the children had mastered the consonant sounds at the ages indicated in Table 2.

The mastery of consonants varies, depending on their position in a word. The general trend is for consonants to be more accurately produced at an earlier age when they occur in an initial or medial position in a word, rather than a final position.

Typically, the inaccuracies a child demonstrates in learning the speech

TABLE 2. Ages at which 75% of Templin's (1957) subjects mastered various consonant sounds.

Age	Sound
3	m, n, ng, p, f, h, w
3.5	y
4	k, b, d, g, r
4.5	s, sh, ch
6	t, th (voiceless), v, l
7	th (voiced), z, zh, j

sounds of a language will fall into one of these types: complete omission of a sound, substitution of one sound for another, or distortion in which there is an inaccurate approximation of the sound. Of these three types of errors, Templin found substitutions to be the most prevalent at all ages. The percentage of speech sound inaccuracies which take the form of omissions shows a marked drop as the child matures, and at the later ages inaccuracies are predominantly substitutions and distortions.

The judgment as to whether or not a child has an articulation problem has to be made in reference to the developmental emergence of sounds. Inaccurate production of a sound at one age may be quite normal, whereas it might be considered an articulation disorder at a later age. Of the various speech sounds, the ones which are most frequently seen as defective are those which tend to be learned later in the developmental progression, such as /r/, /s/, /l/, and /θ/ or /ð/ (Van Riper, 1963).

Such studies as Templin's, which shows results fairly consistent with earlier studies by Poole (1934) and Wellman et al. (1936), indicate that there is some degree of relatively orderly sequential development of speech sounds. These studies, however, provide little information about the processes of speech-sound acquisition, particularly the perceptual processes presumed to underlie production. Why certain sounds emerge consistently later than other sounds is still not known. This may be due to the perceptual and productive complexity of the sounds.

As I have already mentioned, it has been hypothesized that there is perceptual analysis and learning on the basis of distinctive features. If the hypothesis is so, the distinctive features critical for speech-sound acquisition have not yet been identified. Several distinctive feature systems have been proposed, such as the more traditional one, presented earlier, which includes voicing characteristic, manner of production, and place of articulation, as well as that proposed by Chomsky and Halle (1968) which includes such features on vocalic, consonantal, coronal, anterior, rounded, nasal, continuant, voiced, and strident. However, in a recent study of the perception of phonological opposites of three- and four-year-old children, Graham and House (1971) found that neither of these proposed distinctive feature systems, nor other modifications, adequately identified the perceptual parameters used to categorize the speech sounds.

## CHANGES IN COMMUNICATION ASSOCIATED WITH AGING

GERALD J. CANTER

*Northwestern University Speech Clinic, Evanston, Illinois*

This presentation surveys some of the changes in verbal communication associated with aging. A great range of alterations occurs. Some changes may be considered as normal expectations of the biological and psychological aspects of aging, while others are related to more or less specific pathologies which occur frequently in older persons. Another dimension to consider is the facet of communication involved. Though the division is somewhat arbitrary, we shall focus on four areas: voice, articulation, hearing, and language.

This discussion is intended merely to suggest the spectrum of communication deterioration. A complete presentation of the topic is beyond the scope of this paper, and indeed, beyond the scope of the writer.

### VOICE

There is a limited body of research literature concerning the voice characteristics of older persons. Most of this deals with vocal pitch and has been reviewed by Mysak (1966). Young adult males typically produce voice at a fundamental frequency of about 120 Hz to 130 Hz (Snidecor, 1943; Hanley, 1949). Toward middle age, vocal pitch continues to drop. Thus Mysak (1959) reported a median fundamental frequency of 110 Hz for a group of males with an average age of 48 years. Similarly, Canter (1963) found a median level of 106 Hz for a group averaging 57 years. With advanced age, the male voice tends to increase in pitch. Mysak (1959) studied two groups of older men with average ages of 73 and 85 years. The median fundamental frequency was 125 Hz in the first group and rose to 143 Hz in the second group. Among these older males there is also an increase in pitch variability. Mysak views this change as "an increase in uncontrolled variability, or vocal quavering . . . an involutory phenomenon" (1966, p. 155). He suggests several biological and psychological factors which might be related to the pitch changes noted in the voice of the elderly male. Among the biological factors are atrophy of the central nervous system; increased blood pressure; and a variety of respiratory, endocrinological, and muscular changes. He notes that tension and anxiety may affect pitch level and suggests several psychological factors which

could be expected to produce tension and anxiety, such as decreased self-sufficiency, forced retirement, and loss of family and friends.

The aging female does not seem to show vocal pitch changes. Linke (1953) reported a mean fundamental vocal frequency of 200 Hz in a group of young adult women. Almost identical findings emerged from the study of McGlone and Hollien (1963) of two female groups with average ages of 73 and 85 years. The lack of pitch changes in the female voice suggests that the aging female is more stable physiologically and socioemotionally than the aging male.

We will briefly consider frank vocal pathology as it occurs in the elderly. Many vocal pathologies could be discussed, including vocal changes due to hormonal deficiency. But by far the most serious vocal pathology occurring frequently among aging persons is laryngeal cancer. Obviously, this is a life-and-death medical problem. Speech pathologists have a particular interest in it, however, because an early symptom is apt to be alteration in voice quality, and because to the speech pathologist falls the challenging task of helping the postsurgical patient to develop an esophageal voice or to use an artificial voice source. Laryngeal cancer is a problem of increasing magnitude, and it has recently been estimated that over 2000 laryngectomies are performed in this country annually (Spahr, 1971).

#### ARTICULATION

Aside from the knowledge that the speaking rate tends to slow down somewhat with advancing age (Mysak, 1959), there is virtually no information as to what might constitute normal changes in articulation among the elderly. Of particular interest to this group are possible articulatory changes related to dental deterioration. Again, there is precious little data; however, clinical experience suggests that serious speech problems rarely arise on this basis, despite the prominent role the teeth play in speech-sound production. Bloomer (1957, pp. 640-641) states, "It is very doubtful if the absence of individual teeth in adult life can be considered to be a significant cause of articulatory disorders." He goes on to point out, "A completely edentulous person may have some difficulty in making fricative sounds clearly, and the [f] and [v] may be particularly difficult to enunciate. Properly constructed artificial dentures will usually bring a return of correct articulation."

Despite this generalization, Bloomer notes that there is a paucity of research on the effects of dental appliances on speech. He cites a paper by Tench (1927), however, which focused on the necessity to design artificial dentures with regard to the relation of tongue size and movement patterns to tooth position. Tench suggested that a very broad or a habitually retracted tongue might require a cross-bite arrangement of the molars to provide adequate lingual space. Tench also pointed out that the sounds [s] and [z] might be affected by excessive width of the maxillary arch, by excessive thickness of the incisors, or by incorrect anteroposterior positioning of the incisors. Landa (1953) suggested that the rugae be routinely omitted from dental plates to

avoid excess thickness which might take up valuable room required by the tongue for articulatory movements.

The most striking and severe disorders of motor speech in general, and of articulation in particular, in the aging population are the dysarthrias. Dysarthria has been defined as "a disturbance in the execution of motor patterns for speech, due to paralysis, weakness, or discoordination of the speech musculature" (Canter, 1967). Peripheral dysarthrias include those due to progressive degeneration of the cranial motor nerves serving the speech musculature. Progressive bulbar palsy (often one symptom of amyotrophic lateral sclerosis) is such a condition. Here we see a progressive, flaccid paralysis frequently affecting, in order, the tongue, soft palate, lips, and larynx. Articulation is often rendered wholly unintelligible. Velar weakness leads to hypernasal voice quality and to nasal emission on pressure consonants. Vocal-fold weakness causes breathy voice quality, though many patients die before laryngeal involvement becomes evident.

Central dysarthria may arise from damage to the pyramidal, extrapyramidal, or cerebellar components of the motor system. Unilateral upper motor neuron involvement,<sup>1</sup> usually causing a spastic hemiplegia, will often be accompanied by a central facial paresis on the same side as the hemiplegia. However, the effects of unilateral facial and lingual involvement on speech are usually mild and transitory (Brain, 1951; Canter, 1967). Most patients develop adequate compensatory movements for speech with little or no special training. Whenever a persistent speech disturbance is observed in such an individual, one should suspect possible bilateral impairment or the presence of a higher-order disturbance (apraxia or aphasia).

Bilateral involvement of the descending upper motor tracts, as in cases of multiple strokes or tumor, causes pseudobulbar palsy. Darley, Aronson, and Brown (1969) have contrasted the speech symptoms of this condition with those of progressive bulbar palsy. There is usually a marked reduction of precision of articulation, though usually not as severe as in progressive bulbar palsy. Hypernasal voice quality is usually present, also not as severe as in the lower motor neuron disorder. Hypertonia of the laryngeal muscles may lead to a forced, harsh vocal quality, as contrasted with the hypotonic vocal folds of progressive bulbar palsy and the associated breathy voice quality.

Lesions of extrapyramidal motor centers lead to a variety of dyskinesic disorders, all of which may affect speech. In athetosis, chorea, ballismus, and dystonia there is a great deal of involuntary movement and unpredictable shifting of muscle tone. Obviously such dysfunctions of the motor system will lead to breakdowns in articulation as well as to abnormalities of respiration and phonation. In Parkinson's disease, another extrapyramidal disorder, the predominant symptomatology, despite the presence of tremor, is hypokinetic. Slow, imprecise movements of the articulators directly affect articulation. Voice

---

<sup>1</sup>Though this type of involvement is often referred to as "pyramidal" clinically, it is typically based on combined damage to pyramidal and extrapyramidal tracts.

changes are also frequently observed. In this condition, there is frequently a reduction of automatic and associated movement in contrast to relative preservation of voluntary movement. Many of the speech problems of the patient with Parkinson's disease may relate to his inefficiency in using speech automatically and his necessity to consciously program his speech performance.

In ataxic dysarthria, caused by damage to the cerebellum or its projections, the general ataxic symptoms of dysmetria, decomposition of movement, and dysdiadochokinesis are manifest in speech behavior. Scanning speech, where the individual speaks in a syllable-by-syllable fashion, is common; there are some ataxic patients whose speech is markedly dysrhythmic and "explosive." Some of these patients, have a severe neurogenic form of stuttering. Neurogenic stuttering occurs not only in the dysarthrias, but also in some patients with apraxia and in some with aphasia (Canter, 1971).

#### HEARING

Presbycusis, hearing impairment related to aging, is common, presumably due to deterioration of the auditory end-organ and of the central auditory pathways. Spahr (1971), reviewing National Health Survey figures, estimates that between 13 and 25% of our population over age 65 have sufficient bilateral hearing impairment to cause problems in understanding speech and thus to restrict social efficiency. There are somewhere in the order of two and one-half million Americans with significant presbycusis.

The hearing loss of the elderly person often goes far beyond a mere reduction of auditory sensitivity as measured by the pure-tone audiometer. There are frequently problems of speech discrimination, dysacusis, which are not explainable on the basis of sensitivity loss. Such persons are aware of the presence of the speech signal, but they cannot perceive it accurately. The signal has somehow become garbled in its transmission from ear to brain. Amplification is typically not of value to such an individual; in fact, limited fidelity of the hearing aid may exaggerate their problem of discriminating speech. (This is not to say that hearing aids should not be considered for the elderly person. There are many with hearing losses who could profit enormously from amplification. An audiological evaluation should surely be made, to see if a hearing aid would help in any individual case.) When we add dysacusis individuals to those with losses of hearing sensitivity, one person in four over age 60 might be expected to have a handicapping hearing impairment (Subcommittee on Human Communication and Its Disorders, 1969).

The social and emotional impact of hearing impairment on the older individual are often serious. Some persons try to hide their handicap and live under the constant strain of being found out. Their responses to speech may be bizarre, because they would rather guess at what was said rather than ask to have it repeated. With severe losses, depression and paranoid feelings may develop. For those individuals still at work, the vocational ramifications of hearing impairment are profound and obvious.



In communicating with the older hearing-impaired person, one should get his attention before starting to speak specifically. Facing the listener gives him the opportunity to use visual clues to supplement what he gets auditorily. A somewhat reduced rate of speech will help, as will clear—but not exaggerated—articulation. Patients with cochlear involvement frequently have the problem of loudness recruitment, in which small changes in the physical intensity of the signal are perceived as large changes in loudness. The speaker must be sensitive to this kind of problem as he determines how much to raise his vocal intensity level to facilitate comprehension.

#### LANGUAGE

Little information is available regarding changes in language behavior that might be expected to be correlated with aging. However, considerable attention has been given to many of the psychosocial aspects of aging. We should anticipate that language, as a vehicle for expressing thought and feeling, might reflect certain of these changes. Wolff (1959) has reviewed much of this literature. For this paper, however, we will consider but a single contribution, a paper by Gitelson (1948). In this paper, Gitelson focused on six important aspects of psychosocial patterns of older persons: (1) decreased memory for recent events, (2) sharpened memory for past events, (3) increased self-assertiveness (perhaps compensatory for insecurity), (4) depression (caused by isolation), (5) introversion and paranoid attitudes, and (6) free-floating anxiety (in reaction to the death of peers). In our communication with the aged individual, we must be aware that what he says is often expressive of such states and feelings. He may have greater need to express himself in this regard than to express the information which we, as listeners, might be impatient to receive.

Of course, some changes in language behavior are not normal manifestations of aging. The most apparent and dramatic language pathologies are those due to cerebral lesions and catalogued as aphasia. Aphasia occurs in all age groups, but with cerebrovascular accidents being the most prominent etiological agents, it is clear that senior citizens constitute the greater part of this population. The Subcommittee on Human Communication and Its Disorders (1969) of NINDS has recently made a conservative estimate that some 600,000 Americans have survived various types of brain injury (such as strokes, trauma, tumors) with aphasic sequelae. The Subcommittee points out that "even those cases not considered aphasic may show subtle deviations of language and thought when examined by appropriate methods. These impairments may be of no consequence to a majority of patients; but for those whose work requires a high level of competence . . . these impairments may be grave" (p. 16).

Aphasia is usually viewed as a disturbance in language functioning due to unilateral cerebral damage. In the great majority of individuals, the left cerebral hemisphere is dominant for language, so that left brain injury is most

often associated with aphasia. One clinically useful and scientifically defensible breakdown of the aphasic population into more or less distinct syndromes recognizes three major varieties: amnesic (nominal) aphasia, Broca's (predominantly expressive) aphasia, and Wernicke's (predominantly receptive) aphasia. Patients with severe impairments of language in all modalities are frequently classified as having global aphasia.

Disturbances of word retrieval, or word finding, are a common feature of all aphasia syndromes (Schuell, Jenkins, and Jimenez-Pabon, 1964; Goodglass, Quadfasel, and Timberlake, 1964), and thus they are not of localizing significance. When such a problem occurs in relative isolation, we have amnesic aphasia. A patient with this problem usually understands rather well. He tends to speak fluently until he hits a word lapse. His inability to call up the needed word is not at all limited to nouns, but may occur with words of any grammatical class. Typically, it is the word which is most crucial to the communication which causes trouble—the psychological (not necessarily grammatical) subject of the sentence. Words with relatively low frequencies of occurrence in the language also tend to be particularly difficult.

When the damage causing the word-retrieval problem is in the frontal lobe, in the region of Broca's area (area 44), we find much increased difficulty in expression due to impairment of the neural mechanisms involved in organizing and programming motor speech. This impairment is a form of apraxia and renders the patient's speech slow, laborious, and inaccurate. Word-finding difficulties and verbal apraxia are frequently combined with reduced use of connective or function words (agrammatism) in Broca's aphasia. (Just as word-finding problems may occur in relative isolation, so does verbal apraxia [Johns and Darley, 1970]. Verbal apraxia is seen most often, however, in the context of the syndrome of Broca's aphasia.) Like the amnesic patient, the Broca's aphasic tends to have relatively well-preserved verbal comprehension.

In the third major variety of aphasia, Wernicke's aphasia, serious impairments of verbal comprehension are usually noted. It is generally conceded that the damage in Wernicke's aphasia is usually in the auditory association cortex (Wernicke's area). Apparently this damage directly causes the reduction of comprehension, and it indirectly causes the changes in expression which are invariably seen in Wernicke's aphasia. Released from the normal sensory guidance of the auditory association cortex, the frontal motor areas operate autonomously and lead to the production of bizarre misarticulations (literal paraphasia or secondary apraxia), incorrect word selection (verbal paraphasia), and often a copious but largely meaningless verbal output which may include both words and nonwords (neologisms).

#### SUMMARY

Changes in voice, articulation, hearing, and language occur commonly in association with aging. Some of these changes are to be more or less expected as a consequence of normal aging, while others are caused by specific pathol-

ogies occurring frequently among senior citizens. This paper has attempted to provide a survey of varieties of communication changes observed in the aging population.

#### REFERENCES

- BLOOMER, H. H., Speech defects associated with dental abnormalities and malocclusions. In L. E. Travis (Ed.), *Handbook of Speech Pathology*. New York: Appleton, pp. 608-652 (1957).
- BRAIN, W. R., *Diseases of the Nervous System*. (4th ed.) London: Oxford Medical Pub. (1951).
- CANTER, G. J., Speech characteristics of patients with Parkinson's disease: I. Intensity, pitch, and duration. *J. Speech Hearing Dis.*, **28**, 221-229 (1963).
- CANTER, G. J., Neuromotor pathologies of speech. *Amer. J. phys. Med.*, **40**, 659-666 (1967).
- CANTER, G. J., Observations on neurogenic stuttering. *Brit. J. Dis. Commun.*, **6**, 139-143 (1971).
- DARLEY, F. L., ARONSON, A. E., and BROWN, J. R., Differential diagnostic patterns of dysarthria. *J. Speech Hearing Res.*, **12**, 246-269 (1969).
- GITELSON, M., The emotional problems of elderly people. *Geriatrics*, **3**, 135-150 (1948).
- GOODGLASS, H., QUADFASSEL, F. A., and TIMBERLAKE, W. H., Phrase length and the type and severity of aphasia. *Cortex*, **1**, 133-153 (1964).
- HANLEY, T. D., An analysis of vocal frequency and duration characteristics of selected samples of speech from General American, Eastern American and Southern American dialect regions. Ph.D. dissertation, Univ. of Iowa (1949).
- JOHNS, D. F., and DARLEY, F. L., Phonemic variability in apraxia of speech. *J. Speech Hearing Res.*, **13**, 556-583 (1970).
- LANDA, J. H., The importance of phonetics in full denture prosthesis. *Dent. Dig.*, **41**, 154-160 (1953).
- LINKE, C. E., A study of pitch characteristics of female voices and their relationship to vocal effectiveness. Ph.D. dissertation, Univ. of Iowa (1953).
- MCCGLONE, R. E., and HOLLIEN, H., Vocal pitch characteristics of aged women. *J. Speech Hearing Res.*, **6**, 164-170 (1963).
- MYSAK, E. D., Pitch and duration characteristics of older males. *J. Speech Hearing Res.*, **2**, 46-54 (1959).
- MYSAK, E. D., Phonatory and resonatory problems. In R. W. Rieber and R. S. Brubaker (Eds.), *Speech Pathology: An International Study of the Science*. Amsterdam: North-Holland, pp. 150-181 (1966).
- SCHUELL, H., JENKINS, J. J., and JIMENEZ-PABON, E., *Aphasia in Adults*. New York: Hoeber (1964).
- SNIDECOR, J., A comparative study of the pitch and duration characteristics of impromptu speaking and oral reading. *Speech Monogr.*, **10**, 50-56 (1943).
- SPAHR, F. T., 1971 White House conference on aging. *Asha*, **13**, 14-17 (1971).
- SUBCOMMITTEE ON HUMAN COMMUNICATION AND ITS DISORDERS, *Human Communication and Its Disorders—An Overview*. Washington, D.C.: National Advisory Neurological Diseases and Stroke Council (1969).
- TENCH, R. W., The influence of speech habits on the design of full artificial dentures. *J. Amer. dent. Ass.*, **14**, 644-647 (1927).
- WOLFF, K., *The Biological, Sociological, and Psychological Aspects of Aging*. Springfield, Ill.: Charles C Thomas (1959).

## DEGENERATION OF DENTAL AND OROFACIAL STRUCTURES

SIDNEY I. SILVERMAN

*New York University College of Dentistry, New York, New York*

Degeneration is classically defined as a multifactorial process. It is described in its morphologic relationship as a retrogressive pathologic change in cells or tissues, in its physiologic relationships as a deterioration of mental or physical qualities and biologic activities, and as a function of normalcy it is discussed as a deviant change in structure or in function to a state or type other than normal.

Weiss (1968) further describes degeneration as "a continuous succession of processes of change and transformation, going on incessantly in uninterrupted sequences throughout the life span on an individual until death." He states further, "The rate of change for each tissue varies markedly for different periods and further, there is no abrupt discontinuity from which one could date the onset of deterioration or even of aging."

Degeneration is also associated with the unique biologic property of adaptation—a process whereby cells and organs, organ systems or individuals respond in part or in whole to noxious events. In the process of adaptation, these response mechanisms in health and disease states should enable the structures to retain their identity and stability of function. Thus, if any system endures beyond the changes of its parts, the structures are said to be in healthy equilibrium, that is, in harmony with their internal and external environment. When the response mechanism of a structure or system cannot retain its identity and function, the degeneration process ultimately leads to death of the cell, the organ, or the individual.

Thus clinicians and patients, reinforced by these definitions, usually consider the processes of degeneration as disease states which are described and annotated in pathological terms and symbols. These disorders are organized as syndromes, disease entities, or functional derangements which vary from some statistical normative state.

This disease-oriented model system for describing degeneration in general and dental deterioration in specific has skewed treatment, research, and education in dentistry toward extensive expenditures of energy and resources for the study of the pathologic and degenerative aspects of disease. Hence the professions are preoccupied with diagnosis and restorative and rehabilita-

tive procedures. On the other hand, it is my judgment that insufficient energy, insight, and study may have been mobilized for the investigation of the normal physiologic mechanisms of response to the disease. This lack of focus on the physiologic response mechanisms to disease processes explains in part the difficulty preventive health services have in being accepted by patients, by community agencies and resources, and even by the health professions.

This paper will discuss dental degeneration in some detail in each of the areas of definition mentioned above. However, I wish first to review some morphologic characteristics of the orofacial structures which are of mutual interest to the speech pathologist and the dentist. A joint bond is the fact that speech symptoms are diagnostic signs of systemic or behavioral disorders which affect dental therapy.

#### MORPHOGENESIS

The morphogenesis of the orofacial complex of skeletal, muscular, and epithelial derivatives indicates that the original design of the conducting digestive tube persists throughout the evolutionary process. The structure of the early stomadeum with its associated musculature—which engulfed food and which, by peristaltic action, moved nutritional elements through the digestive tract—was modified for more complex function by the introduction of skeletal elements and a more sophisticated nerve supply. The later superimposition of the respiratory requirements to pass air through the food tube required greater speed and specificity of motion of the musculoskeletal elements. The structures and the nervous system thus became more differentiated. The muscles became striated and multipennate in arrangement, the lever system became simplified, the number of head and neck bones were reduced, and the temporomandibular joints became diarthrodial ginglymus joints to serve more effectively these structures. In addition, the nervous system proliferated the brain stem, the higher cortical centers, and the assorted complex cranial nerve mechanisms, to provide the densest and most varied nerve supply in the body. These nerves, which included extensive visceral components of the branchial nerves V, VII, IX, X, and XI, permitted a blending and a continuum of both visceral and somatic functions of the orofacial complex.

For example, the nerve complex can mediate the activity of the lips, tongue, soft palate, and larynx, which are used in the most exquisite motor function of conscious effort, namely, speech. Yet the same structures can almost instantaneously provide vital respiratory protection to prevent aspiration of saliva and debris during the speech process. To effect these exquisite regulating mechanisms during the deglutitive and respiratory processes, the structures have evolved an ingenious valving system. The anatomic and schematic illustrations shown in Figures 1-9 indicate the skeletal support, the contours and tissue spaces of the split muscular conducting tube, and the valving mechanisms which regulate the flow of air and nutritional substances. These illustra-

tions describe the structural elements that dental and speech professions must examine, restore, train, and repair during treatment.

### *Valving Mechanisms*

Figure 1 is a midsagittal section through a cadaver, showing the two tubes



FIGURE 1. Midsagittal section of cadaver. The tubes demonstrate airway passage and food passage crossing anteroposteriorly in the oropharynx.

representing the food passage and the air passage. Note that the thicker food tube passes through the lips and the oral cavity into the oropharynx against the posterior wall of the pharynx, into the esophagus, and down to the stomach. The narrow air tube passes through the nares, through the nasal cavity and the nasopharynx, into the common oropharynx, and crosses forward as it enters the glottis, the larynx, and the trachea, and proceeds into the lungs. These two tubes represent the essential functions in which the maxillofacial structures must participate. Note further the placement of the soft palate which separates the air tube from the food tube in the superior region. Note too that the glottis and the larynx close off the air passage from the food passage in the lower regions of the pharynx. The soft palate

and the larynx in a highly synchronized and organized way can rapidly close off one passage or the other. People do not swallow and breathe simultaneously; they do one or the other in sequence and thus, when a person swallows, breathing momentarily stops. However, a person may chew and retain food in the oral cavity while breathing. This is effected by the depression of the soft palate and its constricting action associated with contact with the dorsum of the tongue. This valving action separates the oral cavity from the airway. It is in this constellation of structure and activity, in which the tissues are continuously and alternately swallowing and breathing, that dental care and speech procedures must be performed, and into which prostheses are placed. These replacements must conform to the activity of the structures, particularly to the action of the soft palate and the tongue, and to the movement patterns of the mandible.

Figures 2 and 3 show cross sections through the horizontal plane at the



FIGURE 2. Horizontal section of cadaver through the head at the level of the dorsum of the tongue, demonstrating the diameter of the oral cavity, and nasopharynx, and the base of the cranium.



FIGURE 3. Horizontal section of cadaver demonstrating the nasopharynx separated from the oral cavity space by the soft palate musculature.

level of the dorsum of the tongue of a cadaver. In this view, the oral cavity has an infinitely larger diameter than does the nasopharynx, which is rather narrow by comparison.

Figure 4 is a schematic drawing superimposed on the cadaver section which

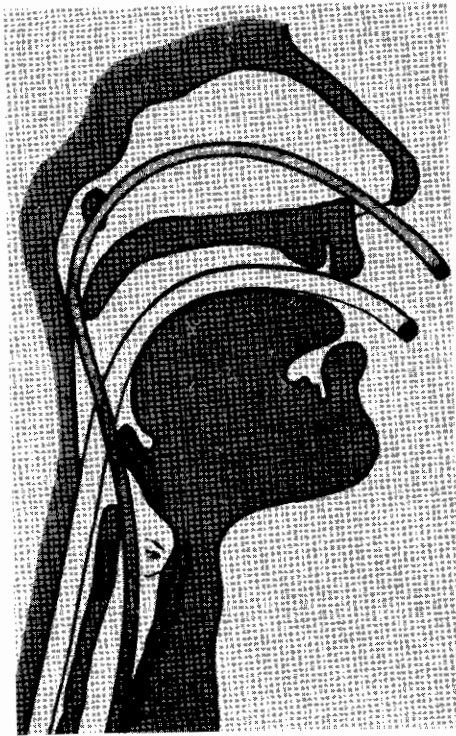

FIGURE 4. Schematic illustration demonstrating airway and food tubes in relation to the soft tissue mass and its oropharyngeal topography.

shows the soft tissue contours. Associated valving mechanisms are shown in Figure 5. Note that at the lowest end of the pharynx on the dorsal aspect there is the cricopharyngeal valve, which separates the lowest recesses of the pharynx from the esophagus. This valve is normally closed during respiration and it opens briefly only during the act of swallowing. In the same inferior recesses, anterior to the cricopharyngeus, is the laryngeal mechanism, which

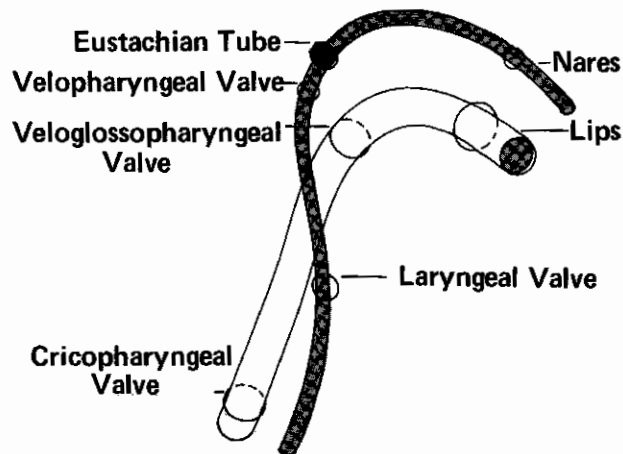

FIGURE 5. Schematic illustration demonstrating valving mechanisms in relation to airway and food passages.



protects the sensitive lungs and is used selectively for the passage of air during speech. At the superior most anterior recesses of the split tube one finds the lips, which provide the oral valving mechanism, and the nares, which are an incomplete valving mechanism brought into use only during forced respiration. The nares are also used in an abortive attempt to hold back the airflow during the production of a nasal snort. These orifices—the two below and the two superiorly—are the principle entrances into and out of the oropharyngeal tube. There are other valving mechanisms either smaller in size or intermediary in location. The eustachian tubes, on either side of the pharynx slightly dorsal and medial to the soft palate, provide a valving mechanism to the middle ear, which regulates the sound pressure levels in the middle hearing mechanism.

The most significant intermediary valve element is the soft palate, which elevates to reach the posterior wall of the pharynx to create the velopharyngeal valve. The soft palate also creates a valving mechanism with the dorsum of the posterior body of the tongue inferiorly and the palatoglossus muscle medially.

There are a series of subvalving mechanisms in which the tongue tip and blade contact the lingual alveolar ridges and the teeth to provide a variety of interruptions in the flow of air to produce consonants. The lips also engage in a valving mechanism with the teeth to produce the so-called "dental sounds."

### *Skeletal Scaffolding*

Figure 6 demonstrates the skeletal supporting mechanisms for the conducting tube. The cranial facial skeleton provides the superior skeletal support for the flexed tube. The cervical spine is the posterior supporting mechanism which lies dorsal to the tube. The two together—the cervical spine and the cranial facial skeleton—provide an appropriate scaffolding to support the suspended contours of the flexed tube. Anterior to the tube are the smaller skeletal elements which permit rapid movement and change in contour of the tube configuration. The mandible is in the most superior part and provides through its joint, and particularly with the external pterygoid and digastric muscles, a mechanism for rapidly enlarging or diminishing the gross contour of the oral cavity. This is significant for both chewing and speech, to provide the gross movement for changing the oral volume of space. The fine movements are then made possible by more subtle changes in the oral space configuration by either the tongue tip or the lips. This significant differentiation between the action of the masticatory muscles and of the tongue muscles is explained by the number of skeletal attachments of each muscle group. The masticatory muscles are attached to the cranial facial skeleton and to the mandible, and thus become two skeletal attachment muscles. This is differentiated from the one attachment or no bony attachment of the lips and tongue. The muscles of the lips on their dorsal end, for example, have just



FIGURE 6. Schematic illustration demonstrating skeletal scaffolding supporting the airway and food passages.

one bony attachment to the facial skeleton. The other ventral attachment is into the orbicularis oris. This relatively less rigid skeletal relationship permits the lips to go through a wide volume of space with rapid and subtle capacity for change in position in tension and in form.

The tongue tip, essentially the intrinsic muscles, on the other hand, has no bony attachments. The intrinsic muscles thus are able to curl, to furl, to roll, and to make fine movements in and about the oral cavity (Figures 7 and 8). The extrinsic muscles, however, have one bony attachment (Figure 8a). Of the structures in the mouth, the tongue has the richest nerve supply, the lips the next richest, and then the masticatory muscles. The density of nerve endings, the arrangement of bony attachments, and their relationship to the changing contours of the oral cavity seem to have been designed for their special functions. Teleologic as it may be, this is a reasonable description of the interrelationships.

The schematic representation in Figure 9 illustrates the skeletal arrangement and the reciprocal relationships of the muscle groups and skeletal elements of the head and neck region: a cranial-facial skeleton, including the upper face; the vertebral column; the shoulder girdle; the mandible; and the hyoid bone.

The hyoid bone and the laryngeal skeletal complex are below the mandible. Here the movement patterns are less differentiated than the mandibular movements, but no less important to the skeletal fixation necessary for either speech

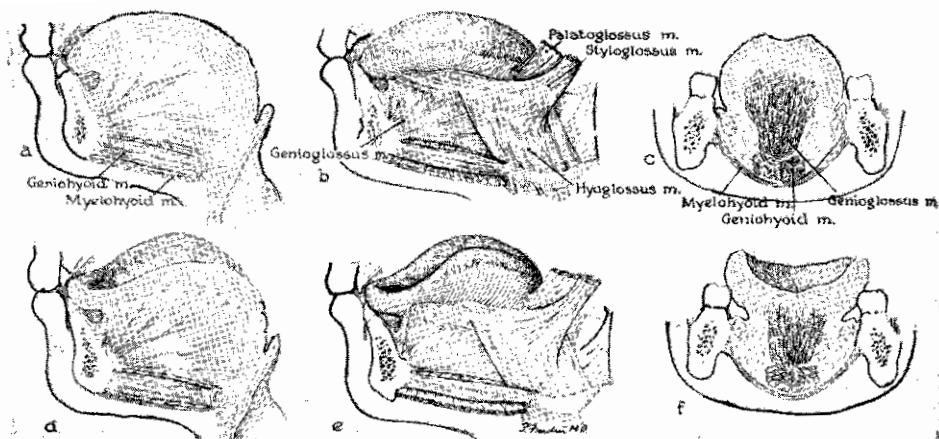

FIGURE 7. The intrinsic muscles have no bony attachments and can be moved for short distances through three planes of space. Therefore, they can execute fine, rapid, and sequential movements for the different acoustic effects required in consonant production.

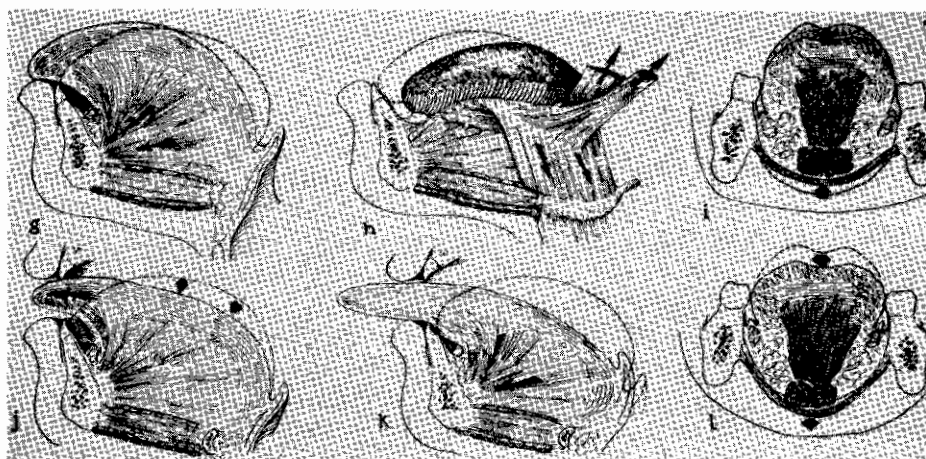

FIGURE 8. The extrinsic muscles have one bony attachment, and the other attachment terminates in the muscle mass of the body and blade of the tongue. The skeletal attachment allows the tongue to be moved as a single mass to varying positions within the oropharyngeal complex. This is a relatively gross movement compared to the movements effected by the intrinsic muscles of the tongue tip.

or swallowing. For example, when it is necessary to elevate the larynx to protect it as food goes into the esophagus, the mandible is fixed during swallowing so that the superior and inferior hyoid muscle complex can elevate the larynx and tuck it out of the way under the tongue. This action widens the lower pharyngeal region above the esophagus so food passes quickly into the stomach and protects the glottis and larynx. Maladaptive fixation is often associated with "tongue thrusting." Contrarily, when the patient is required to open the mandible wide, the hyoid laryngeal complex is relatively fixed

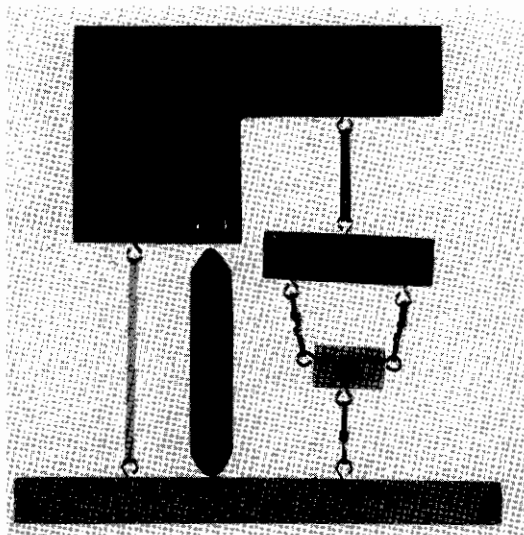

FIGURE 9. Schema of the cranio-facial and cervical skeleton supported by the shoulder girdle. The muscles relating to these elements are distributed to permit alternate fixation of the mandible and hyolaryngeal bones for either swallowing, speech, or respiration. For example, to depress the mandible, the infrahyoid muscles are fixed by agonist and antagonist muscle action to allow the suprahyoid muscles to move the mandible downward. To elevate the larynx and protect it during the act of swallowing, the mandible is fixed in position by the masticatory muscles. Tooth contact and tongue placement between the teeth or alveolar bones also assist in fixation. This action permits the larynx to be elevated by the contraction of the same suprahyoid groups of muscles.

and the mandible is depressed. This alternate fixation of the mandible or the hyoid laryngeal complex makes possible rapid movements and changes in position of the entire spectrum of contour relationships of the oropharyngeal tube.

The foregoing illustrations demonstrate the functional relationships between speech pathology and dentistry as they relate the skeleton and muscle to oropharyngeal space and to the nervous system.

### Summary

In review, the oropharyngeal tissues are a split tube wherein the valving mechanisms expedite the sequential and often simultaneous activities of breathing and speaking, chewing and swallowing. The skeleton expedites the activity of the muscles by a system of supportive and lever mechanisms for fixation. These elements provide the speed and specificity of motion necessary to perform a highly selective low energy movement for speech or a high energy movement for mastication.

The muscle groups, by their radial distribution and fiber arrangement, by the number and location of muscle attachments, and by their facial and connective tissue associations, create the movement and the contour of the spaces for either vowel production, trituration of foods, or ingestion of nutritional substances.

Finally, there are the valving mechanisms which, in consequence of the high neurologic innervation, are a remarkable synthesis of the activity of the orofacial structures. The cranial nerves which serve the orofacial structures are the apotheosis of the whole evolutionary history of the branchial arch derivatives. The cranial nerve complex has a high autonomic nervous system component which mediates the visceral function of the jaws, lips, tongue, and

pharynx, and yet also has a high somatic component which mediates the conscious and voluntary characteristics of tissue function.

#### RESEARCH EXPERIENCES

Insight into this dual visceral and somatic nervous system relationship will expedite and often simplify many therapeutic practices and provide new frontiers for joint research. For example, soft palate function and mandibular movement are two examples of how branchial characteristics of the nerves can be exploited for research and therapeutic purposes.

#### Soft Palate

The soft palate is an important soft tissue muscle mass which is employed to increase the retention of complete maxillary dentures by creating a posterior palatal peripheral seal. To achieve the seal and its associated denture retention, it is essential to control the displacement patterns of the soft palate during impression procedures. Since the soft palate is innervated by the branchial nerves IX and X with their high visceral components from the autonomic nervous system, the muscle mass does not respond as quickly as do, for example, tongue blade and tip to volitional stimuli for changes in tension, position, or movement (Figures 10 and 11). The anterior two-thirds of the

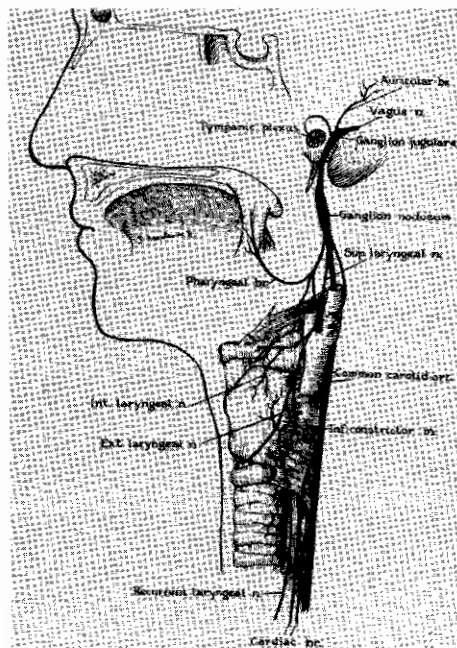

FIGURE 10. Distribution of the vagus nerve (X) fibers to the soft palate.

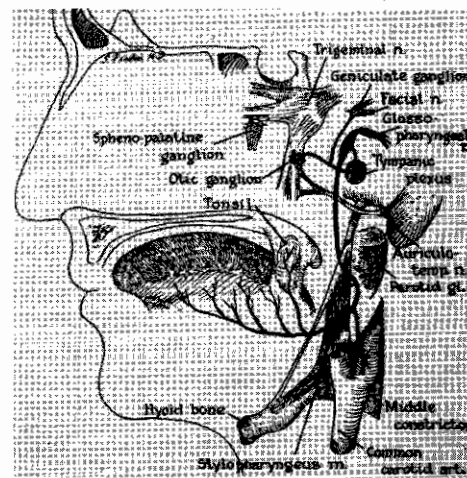

FIGURE 11. Distribution of the glossopharyngeal nerve (IX) to the soft palate and tongue.

tongue, however, is innervated by the XIIth nerve, which is all motor and somatic in origin, like the spinal nerves which are essentially under cortical control (Figure 12). The two muscle groups, fortunately, are joined by a common muscle, the palatoglossus, which sweeps obliquely and radially from the tongue to the soft palate through the anterior pillar of the fauces (Figure

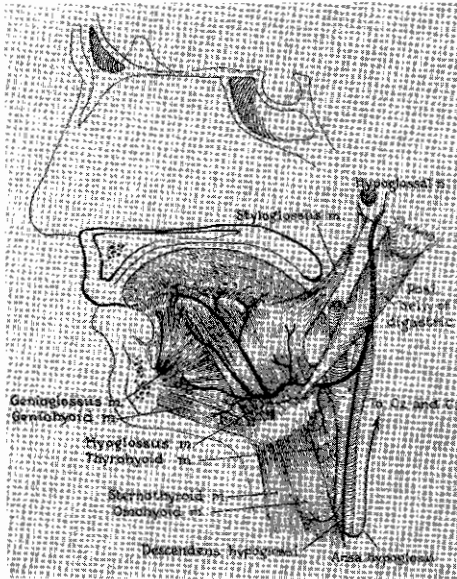

FIGURE 12. Distribution of the hypoglossal nerve (XII) to the tongue.

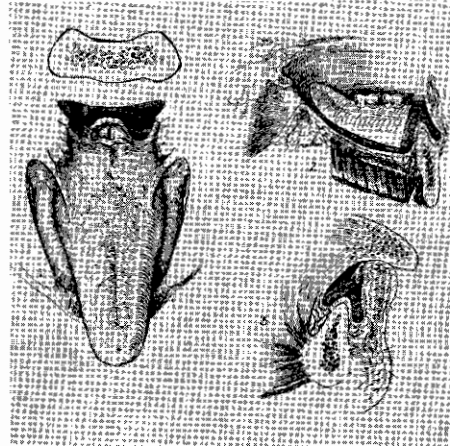

FIGURE 13. Demonstrates anterior placement of the anterior pillar of the fauces when the tongue is protruded. The action of the tongue is related to the soft palate because the palatoglossal muscle is common to the soft palate and the tongue.

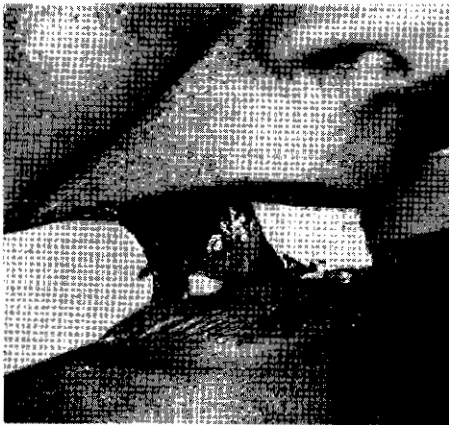

FIGURE 14. Tongue tip is placed under tension against the anterior teeth or impression trays to move the soft palate downward, medially, and forward.

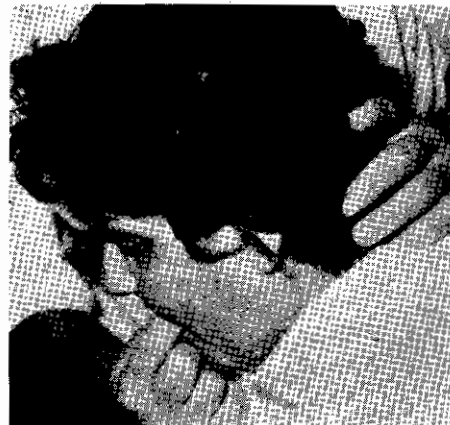

FIGURE 15. Head flexion of 30° provides anterior, downward placement of the soft palate during impressions.

13). It is therapeutically possible, therefore, to control and to modify, in part, the posture and position of the soft palate almost instantaneously by using the tongue tip to activate the soft palate. This can be effected because of the contiguity of the soft palate to the body of the tongue. For example, if the tongue tip is pushed, under tension, against the lower anterior teeth, and if the head is flexed  $30^\circ$ , the soft palate is moved forward medially and downward (Figures 14 and 15). Several studies have demonstrated this. A cineradiographic study (Storch, Silverman, and Landa, 1965) showed the tensor bulge and inferior angle (see Figures 16 and 17); a radiographic study showed the range of motion of the soft palate (Figures 18-21); and a clinical

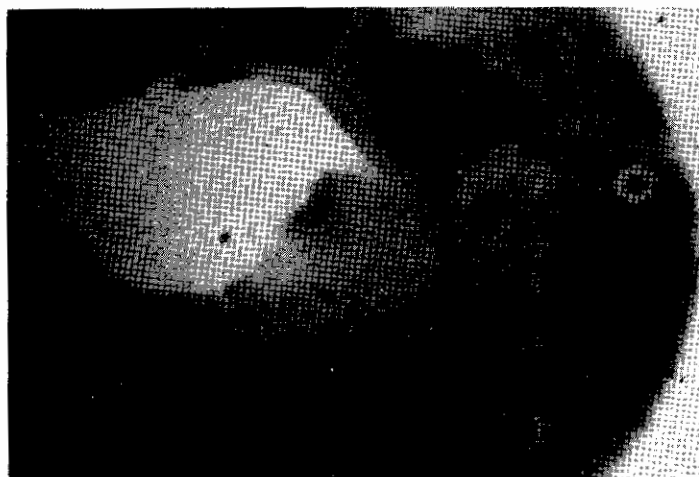

FIGURE 16. A photographic frame from a cineradiologic sequence during a swallow of radiopaque substance while the mass is essentially located in the oral cavity. The substance is just beginning to move into the oropharynx. Note the contour of the anterior surface of the soft palate. It is essentially a straight line extending in a downward and posterior direction from the posterior palatal spine.



FIGURE 17. The radiograph several frames later than that shown in Figure 16, when the radiopaque mass is well into the oropharynx. Note the anterior wall of the soft palate is separated into two parts by an obtuse angle. This angle is where the so-called secondary or "speaking" vibrating line is visible clinically and in the impression.



study (Silverman, 1971) showed the displacement patterns of the posterior palatal seal (Figures 22 and 23).

On the basis of these studies, dentures can now be made 8 to 12 mm longer (Figure 24), to improve retention for patients with very mobile or resorbed alveolar ridges (Figures 25 and 26). The same control of the soft



FIGURE 18. Cephalometric radiograph demonstrating a part of the tongue and the soft palate during speech production of /e/. Note the elevated and posterior position of the soft palate as it appears to contact the posterior wall of the pharynx.

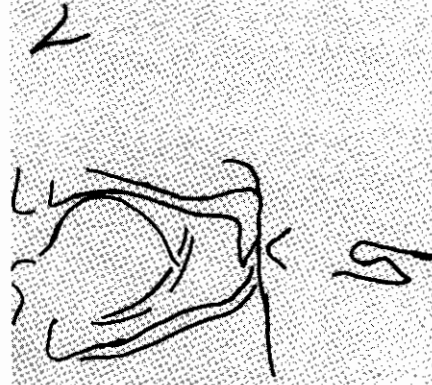

FIGURE 19. Cephalometric tracing of the radiograph shown in Figure 18.



FIGURE 20. Cephalometric radiograph demonstrating displacement of the soft palate when the head is held in 30° flexion and the tongue is held in active tension against the index finger in the position of the lower incisor. Note the relatively forward and downward displacement of the soft palate.

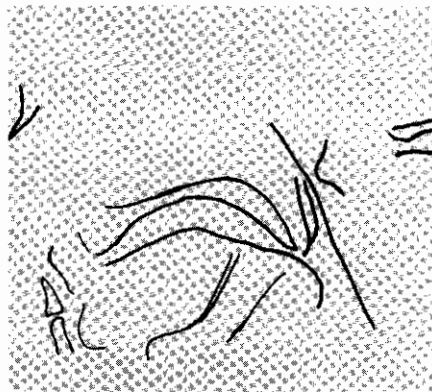

FIGURE 21. Cephalometric tracing of the radiograph shown in Figure 20.



palate makes it possible to make impressions for palatal lift prostheses for incompetent palates, or to teach patients to elevate the soft palate by modifying the position of the dorsum of the tongue.

The analysis of the nerve supply to each part of the tongue demonstrates the mechanism by which a voluntary act may induce a less voluntary act. The hypoglossal nerve serves the anterior two-thirds of the tongue, and the vagus and the glossopharyngeal serve the posterior wall of the pharynx, the soft palate, and the posterior third of the tongue. The contiguous activity of the palatoglossus forces the placement of the soft palate.



FIGURE 22. Photograph of an impression of the soft palate demonstrating tissue marked with indelible pencil. The anterior line is the vibrating line observed when a patient uses discontinuous, loud, vigorous, and abrupt production of /a/, /a/, /a/. This results in a movement at the anterior border of the soft palate. The second, more posterior line is the posterior or "speaking" line where the soft palate elevates posteriorly during normal connected speech. The tissue between the two vibrating lines has the minimum displacement pattern of the soft palate during speech and normal respiratory function and may be employed for complete denture border contact.



FIGURE 23. An impression and a complete denture prosthesis demonstrating the additional length of a denture covering the area between the anterior and posterior vibrating lines observed by speech production methods.

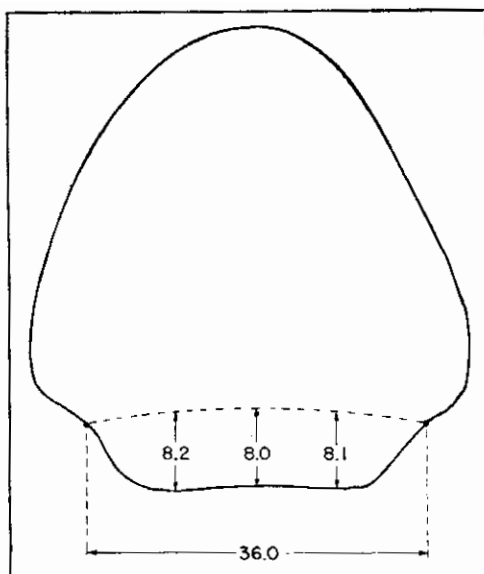

FIGURE 24. The average additional length of dentures which relate to the soft palate area. The distances shown are the mean extensions for 92 patients.

### *Mandibular Guidance Mechanisms*

The second example of how neurophysiological phenomena can be used relates to the faulty sibilant in the mandibular glide, now under study (E. T. Silverman and this author, work in progress at New York University). The study is predicated on the therapeutic practice of reducing or modifying the distances of the interincisal gap for the passage of a stream of air. This retraining process depends on two major muscle group functions in sequence. First, the masticatory muscles must move the mandible from the respiratory rest position or from another phoneme-producing position to an incisal gap position for the /s/.

The second sequential muscle action is the movement of the body of the tongue to the position in the oral cavity where the tongue tip and blade can groove to blow a stream of air through the incisal gap. In this sequence, the mandibular movement is the grosser skeletal movement required to permit the finer movements of the tongue to produce the /s/. This differentiation of the movement skills can be exploited in therapy. It is generally accepted therapy for /s/ treatment to have a patient or a child learn to manipulate his tongue. In some instances, therapy manuals suggest the movement of the jaws or the approximation of the teeth, a difficult task at best for many children and even for adults who are not able to quickly generate movement patterns with skill when they must find appropriate tooth gap distances. However, if the patient is permitted to incise several times on a tongue blade the thickness of an incisal gap (Figure 27), a proprioceptive stimulus is initiated. This position, assumed under pressure several times, conditions the patient



FIGURE 25. A patient whose loss of alveolar bone is so extensive that the use of the soft palate increased the retention of a denture. Note the collapse of the upper facial contours.



FIGURE 26. Alveolar bone loss of the patient shown in Figure 25.



FIGURE 27. The use of a tongue depressor to reinforce the incisal gap position for the production of a sibilant. Repeated closures of 10-sec duration induces a proprioceptive experience to reinforce the movement to the optimal mandibular position for production of /s/.

to move the mandible to the appropriate incisal gap position just before the tongue movement is effected. The low adaptive nature of proprioceptive stimuli to adventitious or repeated stimuli makes the training of new mandibular postures difficult. In effect, posture stimuli are habitual, and defective sibilant production may often resist reduction. However, if new, strong stimuli supersede the old habitual postures, the mandible can be deconditioned and conditioned to assume new postures.

The learning process of moving or gliding the mandible to the gap position can thus be facilitated by strong incisal biting pressures. Biting firmly several times on the tongue blade, or on a material positioned to create a proper incisal gap position which is associated with successive tongue actions, makes the reduction of the distorted sibilant a simple procedure providing there are no other dental or neurologic interferences. This learning procedure by the tongue is also made possible by the 1:4 nerve fiber to muscle fiber ratio which facilitates the deconditioning and subsequent conditioning of new habits.

#### DEGENERATIVE PROCESSES

There are many degenerative changes that may occur after maturation of the dental structures and their adnexae. They include metabolic disorders, the arthritides, dento-alveolar disease, degenerative muscle functions, asymmetries, epithelial degeneration, and nervous system degeneration.

##### *Metabolic Disorders*

The skeleton may have serious disturbances in its metabolic processes. For example, acromegaly may result from a tumor of the pituitary gland. The size of the bony contours increases, manifested in gross disproportionate growth patterns of the mandible and maxilla, elongation of the face, and changes in opposing tooth articulation; there are diastemas and soft tissue changes which often create speech disorders. The lips and tongue become grossly enlarged and lose some of their motor power. Even peripheral sensory degeneration may take place. There are, therefore, associated with these skeletal changes gross dental derangements and often secondary speech derangements. Figures 28, 29, and 30 demonstrate these changes in a patient with acromegaly.

##### *The Arthritides*

Arthritis of the vertebral column, the temporomandibular joint, or the hands will restrict motions in neck flexion and rotation in mandibular motion and is often associated with personality disorders (Figures 31 and 32). These symptoms may affect speech patterns as a result of lost energy levels. However, in those patients who wear prostheses, the postural disorders change the hinge relationship of the jaws, and patients may suffer tenderness to their



FIGURE 28. Profile of patient with acromegaly. Note the elongated facial skeleton and thickened soft tissues of the lips.



FIGURE 29. Full-face view of acromegaly patient. Notice that vertical length is increased to a relatively greater linear distance than is the width of the face.



FIGURE 30. The lips are markedly thickened in acromegaly, as is the tongue. This increased bulk is associated with degenerative processes. There is a loss of strength and speed of motion even though there is an increase in bulk. There is a pathologic hypertrophy often associated with distortion of speech.

normal, natural teeth. Other teeth with fillings which are quiescent, or in which nerves have died, may suffer from occlusal traumatism and become acutely painful. Patients who wear prostheses develop mucosal irritations because of altered joint function, and it is important not to overtreat or over-adjust these patients.

There are patients who suffer tumors of the jawbones, fractures, and other trauma—all of which result in marked bone loss, derangement of soft tissue, and occlusal dysfunctions. These disorders may also be associated with primary dental disorders and secondary speech defects.

#### *Dento-Alveolar Disease*

The loss of teeth and dental alveolar structures may result from dental disease processes. Often the denture replacements do not adequately restore facial height, facial topography, or dental arch form and tooth position, and speech distortions and impaired dental function often occur. Sherman (1970) discusses the effect of changes in vertical dimension on speech intelligibility (Figures 33 and 34). He finds that changes in vertical dimension of occlusion

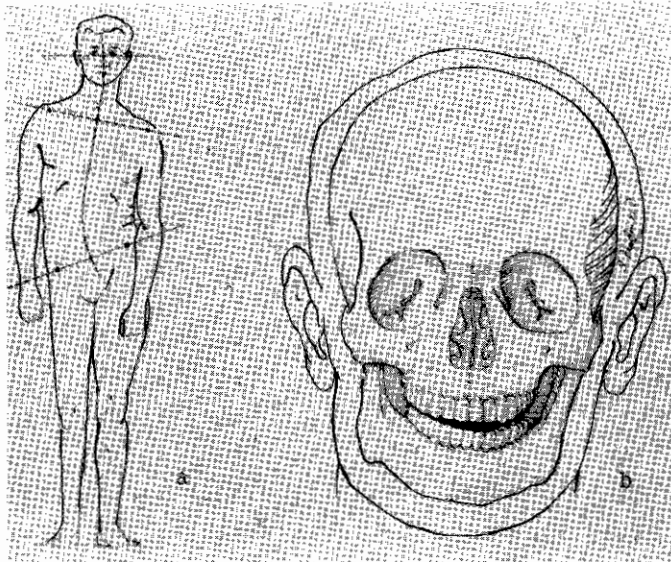

FIGURE 31. The figure schema (a) demonstrates how the head may be held erect (note eye line) even though the shoulder girdle and the hip line are deviated from the horizontal by disease of the joints. In (a) the mandible is suspended in part by gravity and may hold a favorable occlusion relationship to the maxilla. In (b), however, if the neck causes serious disturbance in the horizontal placement of the eye line plane, the mandible is held in an unfavorable occlusion position and a pathology inducing posture of the mandible may be assumed.

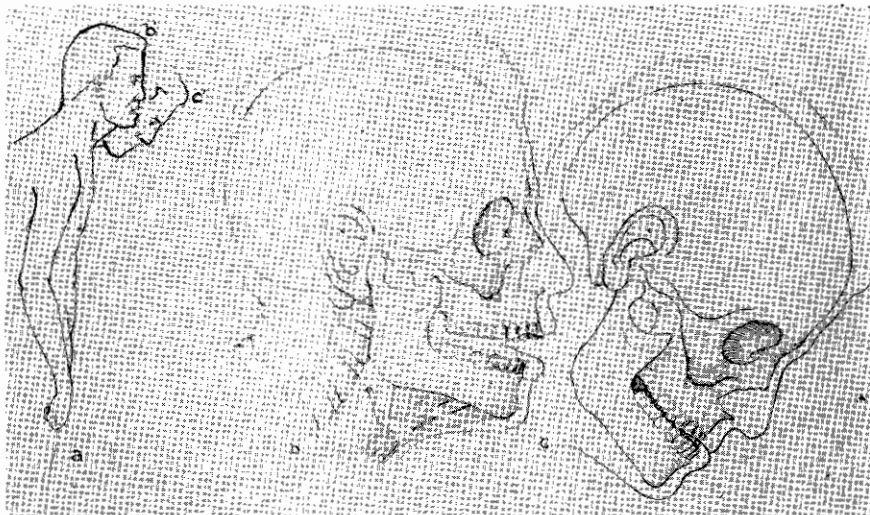

FIGURE 32. The figure schema in the midsagittal plane demonstrates in (b) that moderate flexion associated with joint disease causes an open-bite relationship, and in (c) a more extensive flexion of the neck is associated with anterior tooth prematurity. This prematurity occurs because to maintain a patent airway the mandible is displaced forward by a translation movement. The changes in posture are associated with maladaptive movements of the tongue and contour of the airway during speech.

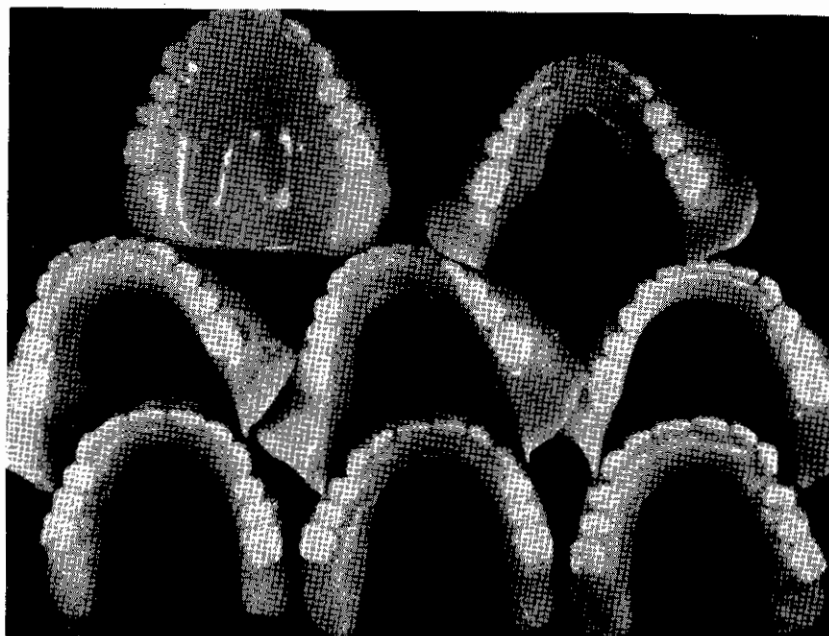

FIGURE 33. The dentures the patient wore in random order to test the number of speech distortions he produced with differing vertical dimensions of occlusion. The patient read the "Rainbow Passage" during a tape-recording session. Trained speech pathologists evaluated the distortions. The patient's speech was tested with (1) dentures he had worn for a long time, (2) another set with a closed vertical dimension, (3) a third set patently opened excessively, and (4) a fourth set with "appropriate" restoration of facial height generally practiced in dental care. It was attempted to vary only the vertical component of occlusion, keeping the arch forms essentially identical. (Photo courtesy of Herbert Sherman, 1970).

change the distortions in speech. Finally, esthetic derangement, such as demonstrated in Figures 35 and 36, is also associated with the sequelae of acquired or congenital micrognathia, macrognathia, asymmetries, and anodontia.

#### *Degenerative Muscle Functions*

Loss of teeth and the collapse of facial form often cause muscular hypertonicity. The tonicity of the facial muscles depends, in part, on support of the tooth and alveolar bone scaffolding. If these latter are lost, the muscles collapse, with gross disfigurement, loss of strength, and relatively unesthetic contours. These symptoms may be associated with paralysis and the loss of teeth, as in scleroderma (Figures 37-39).

Hypertonicity is also associated with malocclusions. For example, in the dynamic states of speech or swallowing there often is excessive perioral contracture, and in the static state of respiratory rest the lips may be fore-

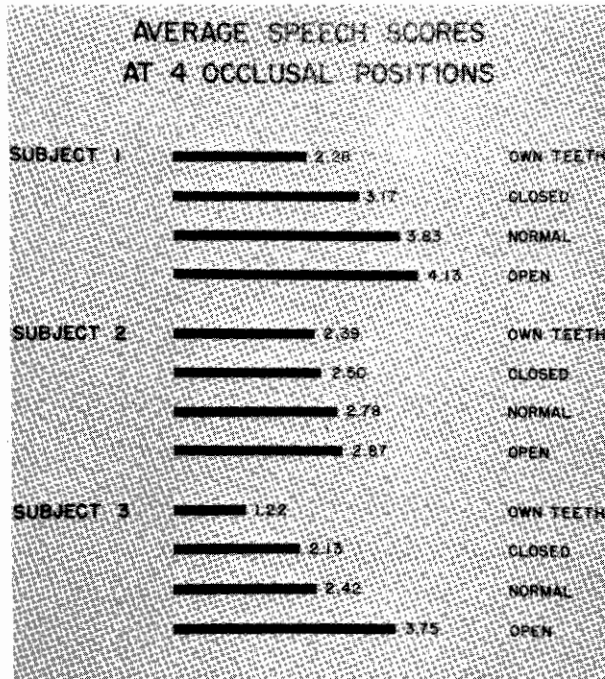

FIGURE 34. Speech scores of three patients using test dentures. (Courtesy of Herbert Sherman, 1970.)

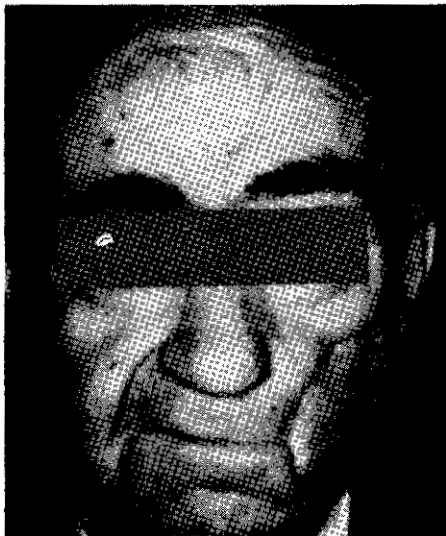

FIGURE 35. Seventy-two-year-old patient who had an invasive infection of the cheek (noma) at age six. A tube graft was taken from his forehead to repair the cheek defect. The full-face view shows the donor site on the forehead and the recipient site on the cheek.



FIGURE 36. Sagittal view of the cheek of the patient shown in Figure 35. The recipient site is 1.5 times larger than the donor site, which indicates the difference in the growth rate of the cranial and facial portions of the head. The patient has had masticatory and speech problems since the age of six.





FIGURE 37. Patient with scleroderma, a degenerative disease associated with collagen disorders. The skin loses its elasticity, and the patterns of lip movement are limited to a small displacement during vowel and consonant production in connected speech.

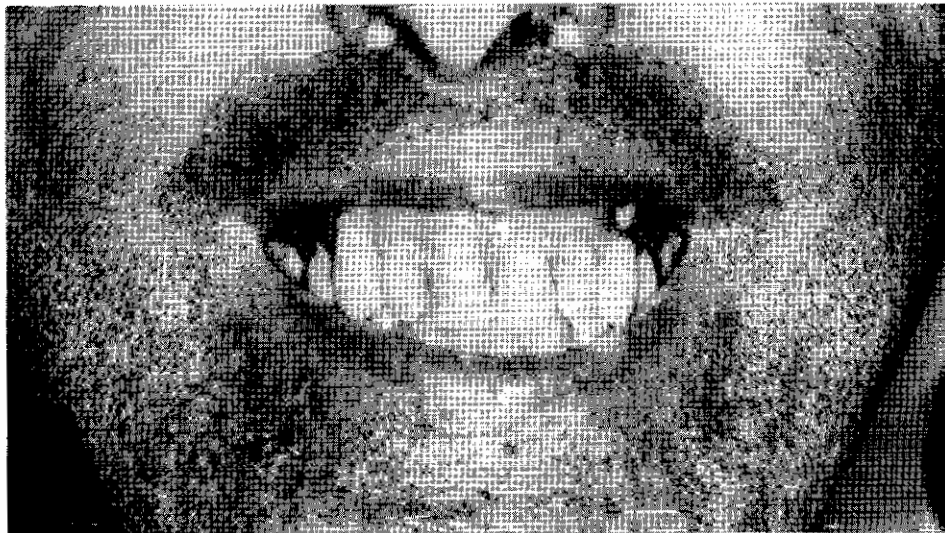

FIGURE 38. The maximum mouth opening the patient shown in Figure 37 could achieve during discrete sound production. This photo demonstrates the opening when producing /e/. Note the teeth are held in contact to provide more leverage for contraction of facial muscles.

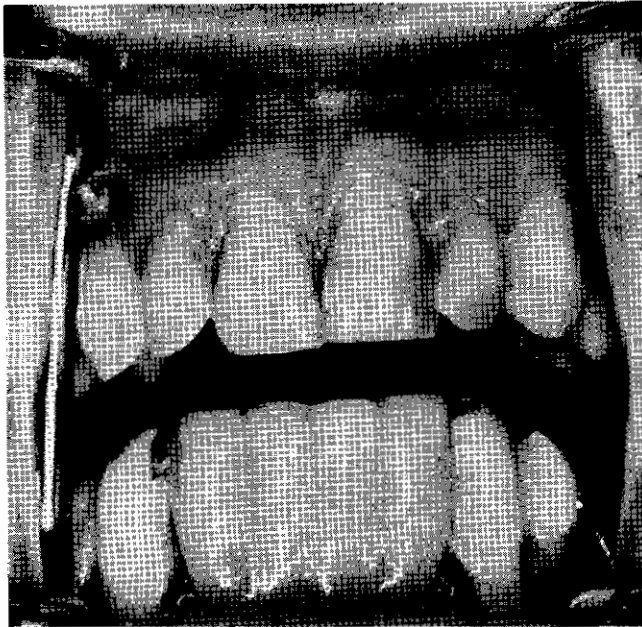

FIGURE 39. The maximum mouth opening the patient shown in Figures 37 and 38 could achieve for mastication. It was necessary to use a frame to hold his lips apart to photograph the interocclusal opening. The patient created therapeutic difficulties in restorative and prosthetic treatment.

shortened. Often in the patient with open bite the upper lip does not cover the teeth adequately at rest or during swallowing (Figures 40-42), and there is much *materia alba* on the teeth. In the edentulous patient, other hypertonic changes are associated with the increased tongue size. The tongue becomes the fixing element to stabilize the mandible during swallowing. It is also the principle masticatory organ. Hence the tongue's bulk strength and activity are increased.

#### *Asymmetries*

Patients who suffer from neurologic deficits such as Bell's palsy (Figures 43 and 44), cerebral palsy, Parkinsonism, or cerebral vascular accident develop irregular and unreciprocated muscle balance action which exacerbates dental disease and interferes not only with denture wearing but also with speech.

Finally, there are the degenerative processes such as muscular dystrophy or other wasting muscle diseases, associated with nerve loss. Clinicians also occasionally encounter problems of muscle agenesis.

#### *Epithelium*

There are also pertinent degenerative processes associated with the epithelial structures and their derivatives. For example, we find an increase in periodontal disease which is essentially a disease initiated in the marginal epithelium

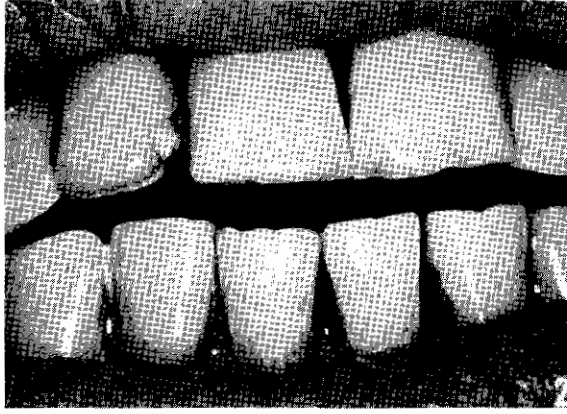

FIGURE 40. Patient with a closed occlusion contact position diagnosed as an open bite. The opening was developed in the adult dentition in association with cervical arthritis over 20 years, during which extensive dental fillings were placed, one at a time. The patient developed the open bite by (1) cervical arthritis, which allowed gravity to change the position of his mandible, and (2) iatrogenic processes in dental care requiring progressively placed gold inlays to accommodate changing hinge relationships of the temporomandibular joint.

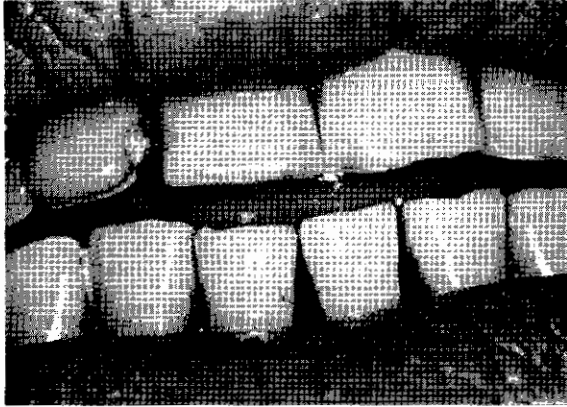

FIGURE 41. Patient shown in Figure 40, demonstrating tongue position during swallowing. The tongue is interposed between the incisal gap and is associated with tongue-thrust swallowing. Tongue pressures created periodontal disease and diastema of the anterior teeth.



FIGURE 42. Patient shown in Figures 40 and 41, demonstrating contraction of perioral musculature during tongue-thrust swallowing.

around teeth. The mucous membrane invades the periodontal ligament, causing loss of periodontal ligament and bone and the onset of tooth mobility and infectious disease. There is a series of other infectious processes of the mucous membrane, such as the mycoses, viral aphthous ulcerations, dyskeratosis, ranging from leukoplakias to the malignancies, and disturbances in salivary secretion, including xerostomia (the dry mouth) and excessive salivation (Figures 45-47).

With advancing age, secretory function so diminishes, we have patients suffering from the almost complete loss of salivary and other mucous secretions,

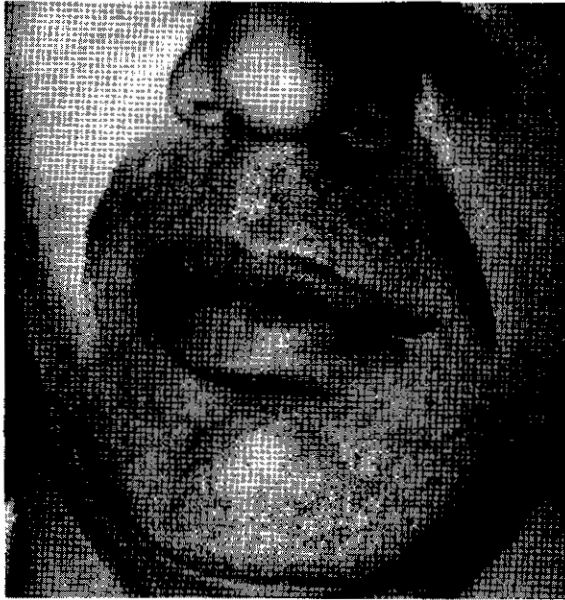

FIGURE 43. Patient with Bell's palsy demonstrating facial asymmetry.

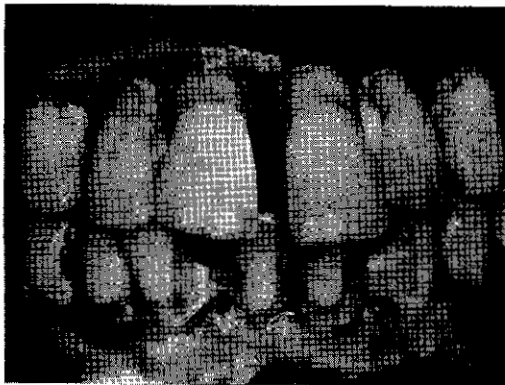

FIGURE 44. Patient shown in Figure 43, with severe periodontal disease associated with paralysis of the facial muscles which cannot maintain periodontal oral health by normal muscle function. The dental arch is disrupted by the loss of muscle equilibrium between the tonus of the abnormal facial muscles and the normal tongue.

which makes it difficult for them to wear dentures. The loss of saliva with its bacteriostatic and adhesive properties renders them more liable to injury and infectious processes.

### *Nervous System Structures*

Finally, we have degeneration of the nervous system and its effect on dental function. Patients often experience sufficient sensory deprivation and do not perceive many of the irritating processes; they may have difficulty in oral discrimination and localization. Most significantly, they experience sensory distortion which is associated with a syndrome called "the burning mouth syndrome" (Silverman, 1967). The problem is part endocrine, part personality dysfunction. These patients are unable to inhibit the minor traumas that

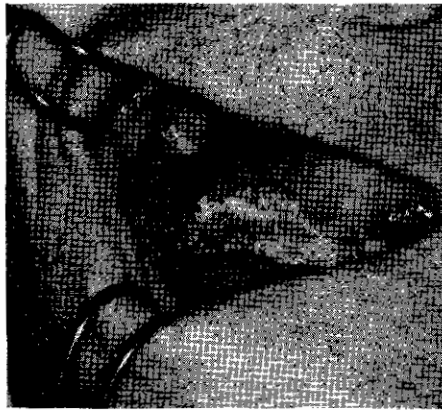

FIGURE 45. Patient with carcinoma of the lateral border of the tongue.

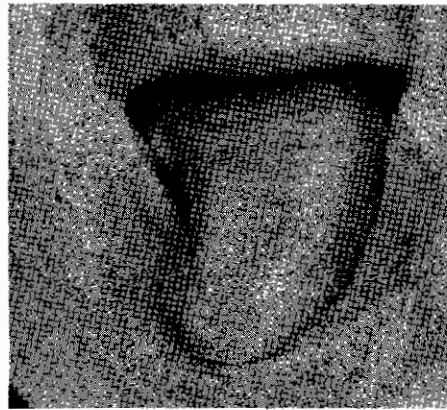

FIGURE 46. Patient shown in Figure 45, after surgical reduction of the carcinoma. Note the surgeon left the free tongue tip because it is essential for effective speech.

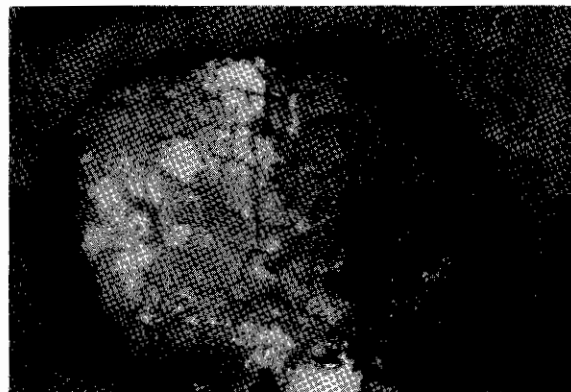

FIGURE 47. Patient with extension leukoplakia which inhibits the fine movements of the tongue and is associated, in this patient, with reduced sensory discrimination skills.

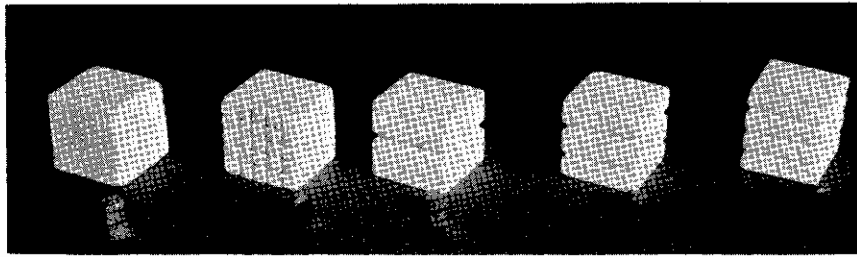

FIGURE 48. The rectilinear forms used in oral discrimination skill test administered to edentulous and dentulous patients. The larger plaster forms are used for visual identification cues after the smaller metal forms are placed in the mouth. Five additional forms with more curvilinear surfaces are also used in this test.

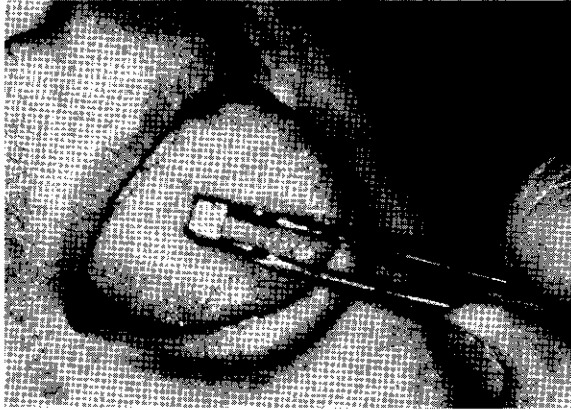

FIGURE 49. Method of placing the forms shown in Figure 48.

**MEAN STEREOGNOSTIC SCORES  
UNDER DIFFERENT CONDITIONS**

Dentulous Subjects

Age 20-31

Age 50-72

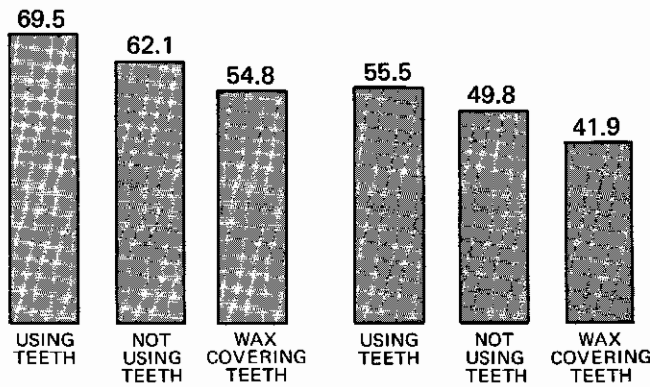

FIGURE 50. Mean scores in tests of oral discrimination skills. The highest numbers demonstrate the best skills in identification of the forms.

come from chewing and from wearing dentures, and they often are constantly aware of small irregularities in the contour of the teeth and the mucous membrane.

Denture wearers have a reduction in oral perceptual skills when compared with dentulous patients (Litvak, Silverman, and Garfinkel, 1971) (Figures 48-50). At New York University we are currently examining the oral discrimination skills of patients who require removable prostheses, to see if denture skill learning can be predicted on the basis of the test.

#### TISSUE RESPONSES TO DENTAL DISEASE

The tooth structure and the investing structures of gingiva, periodontal ligament, and alveolar bone may be considered a dental unit. Disease that affects any of these usually protects or destroys the others. For example, when excessive stress is placed on tooth structure in mastication, the enamel and dentin may abrade and thereby resolve the occlusal trauma before it can affect the periodontal and alveolar bone. On the other hand, if the tooth substance does not abrade, the excess forces may cause alveoclasia; when this is associated with plaque formation, periodontitis may develop, and tooth mobility, pathogenic gingival crevices, infrabony pockets, and other signs of overt clinical periodontal disease may result. Similar tooth mobility induced by prolonged occlusal trauma will move the tooth out of the stress-inducing area and thereby prevent a more acute pulpitis from causing pulp necrosis. Therefore, dental pathology may be in part a protective mechanism often manifest as a chronic disease state which by a feedback response mechanism aborts the disorders of dental disease processes.

Figures 51 and 52 demonstrate extreme abrasion to the gingiva line with little or no periodontal disease. Figures 53 and 54 show no wear of teeth but extreme precocious periodontal disease with exfoliation and malalignment

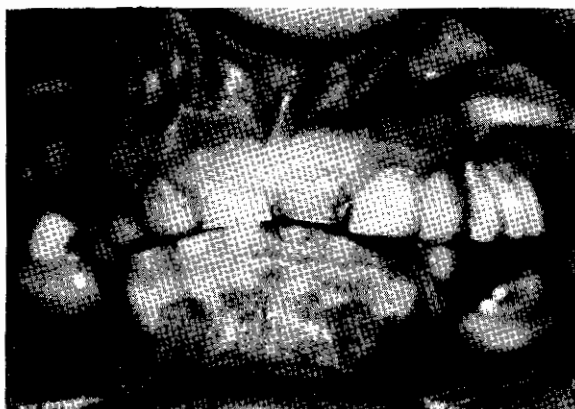

FIGURE 51. Patient with extreme abrasion, demonstrating marked loss of facial height in the respiratory rest position and in the occlusal contact position. This patient had marked speech distortion on sibilant and dento-alveolar sounds.





FIGURE 52. Open-mouth view of the patient shown in Figure 51, demonstrating the extreme abrasion of the lower teeth with no overt periodontal disease. Treatment required restoration of tooth length to increase vertical facial height at rest and for occlusion. Speech and facial esthetics improved by restoring tooth height.

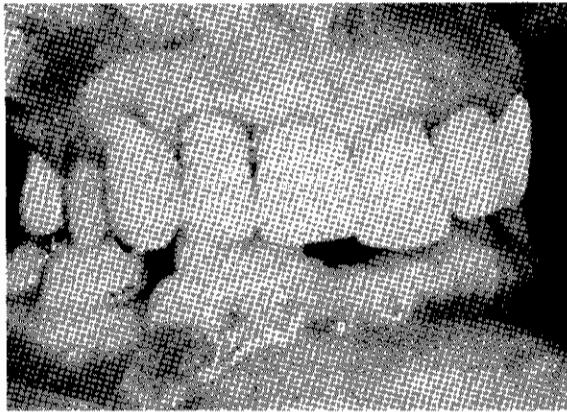

FIGURE 53. Patient with little abrasion of teeth although partially edentulous. This patient has marginal gingivitis in some areas and severe vertical loss of periodontal alveolar bone. The marked overbite and the missing teeth were associated with severely restricted jaw movement during incision and speech.

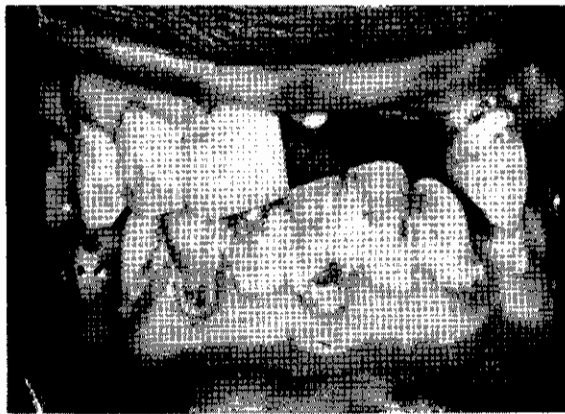

FIGURE 54. The extensive materia alba and his edentulous areas caused this patient to restrain opening his mouth when he spoke. He was embarrassed by the appearance of his "schmutz pyorrhoea." It inhibited his loudness level and his dento-alveolar sounds. The psychogenic and anatomic factors affected mastication and speech function.



of teeth. These clinical conditions induce both articulatory and voice distortions. The abraded teeth not only make it difficult to produce satisfactory linguodental, labiodental, and sibilant sounds, but also tend to require the patient to keep the oral volume diminished during vowel production. The patient tends to reduce the loudness level to reduce the distortion effect during louder levels of speech.

These degenerative processes are evident to dentists, and I urge that speech pathologists learn to read the biologic characteristics of tissue alteration and its relation to speech distortion. Often the arrangement and articulation of teeth can be used to improve speech; contrarily, poor arrangement of teeth will create speech problems. From a clinician's point of view, I would like to stress that speech signs are an important symptom for making judgments about dental treatment, particularly prostheses. Patients learn to wear prostheses, and it is important that motor performance be assessed for its basic neurologic reflex integrity, the availability of proper skeletal form and soft tissue relationships, and finally, the intactness of the nervous system from an oral perceptual level to an intellectual symbolic level. Speech rate, pattern of utterance, and meaning of speech are all important factors a dentist should consider when judging how much dental care a patient can cope with and what the extent of care should be. These phenomena suggest avenues for research.

#### PATHOPHYSIOLOGIC EQUILIBRIUM

I would like to summarize this part of my paper with a schematic representation of much of what I have stated. The chart in Figure 55 organizes the structure, functions, and diseases into a constellation which, in my instance, is viewed from the egocentric posture of the dentist in the axial position. A speech pathologist or any other health service scientist could place himself at the center and travel the same route to therapy or to research.

In this illustration, health represents a state of equilibrium between normal physiologic activity and the pathologic processes of disease. Shifts in this equilibrium are manifested as clinical symptoms. Dental therapeutics are directed toward preventing and reducing these signs. However, to achieve dental health, treatment must include management of the basic tissues, organs, and organ systems during their multiple and joint activity. This chart demonstrates the responsibility of the clinician to examine the symptoms against the background of the whole patient, to observe the morphology and activity of the tissues, to fractionate the separate functional systems, to note the interaction of these symptoms and their potential for repair and recovery, and then to determine a therapeutic procedure that will create a more favorable state of health. It is against this ebb and flow of health and disease that a dentist must provide dental service, not against the idealized condition for the nonexistent "normal" patient. Thus, for example, if a dentist wishes to reduce a clinical sign of pain or inability to chew, or if the speech clinician wishes to reduce a sibilant distortion, the dentist or clinician, starting in the center of the chart,

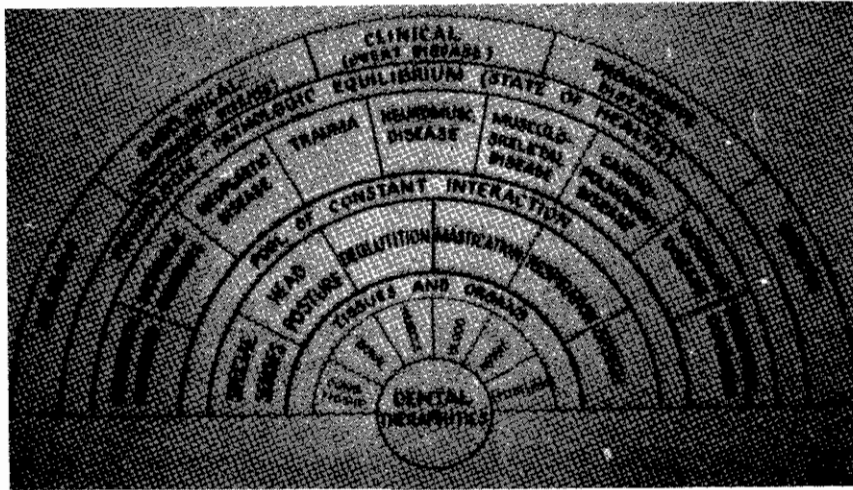

FIGURE 55. Chart demonstrating the relationships between dental therapy objectives, tissues and organs, oral function, and disease processes, and symptoms relating to health and disease.

must study the basic tissue structure, treat it, repair it, modify it, examine it, and in one way or another relate and manipulate it.

Thus, for example, if the mandible must be moved or the lips contracted, or a verbal auditory stimulus is directed to the nervous system, the functional response of the oral structures must be within the confines of the adjustment potential of a neuromuscular disease, a metabolic disorder, or a congenital disorder. Only as we are routed through the pathologic-physiologic equilibrium can we reduce the symptom. One cannot reduce the symptom without treating either a structure or a functional system.

#### LIFE SPECTRUM PROCESSES OF HEALTH AND DISEASE

There have been frequent references to equilibrium and normalcy. I would like to conclude with a discussion of the concept of equilibrium, and on the substance of what is implied by the term *normal*.

Clinicians, in my judgment, should view deterioration as they must view life and death, as a constellation wherein the equilibrium between normal physiologic processes are in equilibrium with the inevitable processes of disease. Figure 56 schematically represents a life spectrum review of the interaction of the several physiologic systems which regulate health and disease. In the child, disease is usually overcome and health is expressed as a state of positive equilibrium in physical and psychic function and continues to increase quantitatively through young adulthood. In middle adulthood, as people survive chronic illnesses and as degenerative processes qualify the physiologic processes, a series of maladaptive adjustments to stress, disease, and injury

creates the morphologic and physiologic alteration we call disease. Many clinicians and patients approach health and disease as simplistic alternatives, and jointly seek optimal health because they choose to identify themselves statistically with group norms rather than coping with the patient's own unique characteristic adjustment, both potential and real. My premise is that health is a state of equilibrium between a unique state of disease and a statistical norm. Treatment is directed to restoring as stable an equilibrium as possible where a patient functions with levels of performance appropriate to his unique biologic and psychosocial potentials. Finally, when the patient is in negative equilibrium—that is, when the disease continues to create marked equilibrium—the patient requires supportive therapy from his external environment. When the patient is in a positive equilibrium, therapeutic agents and processes should be incrementally removed until the patient's equilibrium is self-sustaining. However, there is a corollary. If one aspect of the patient's positive equilibrium tends to dominate and inhibit the other processes of adjustment, this excessive aberration must be restrained.

Has this model been heard before? Of course it has! Every clinician, every good teacher instinctively understands this method of instruction or care. Why do I restate it? Perhaps Goethe tells us why. His Faust expresses the

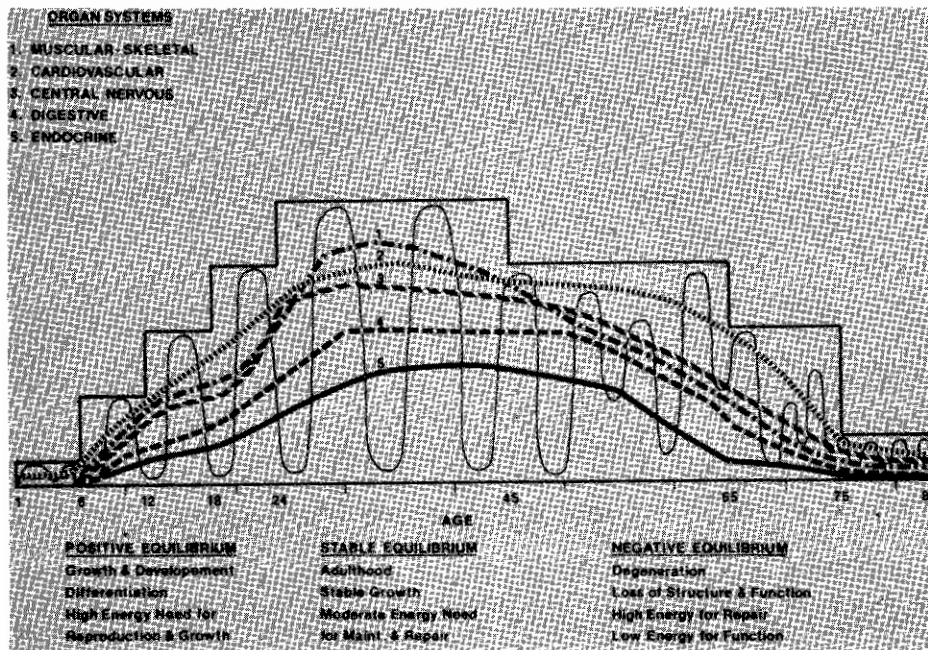

FIGURE 56. A life spectrum chart of organ system processes of growth, development, maturation, and degeneration relating to the state of homeostasis and equilibrium. The sinusoidal curve represents the steady-state interaction of the separate systems.

paradoxical desire of man to fix for eternity the beautiful moment and yet go on living. He exclaims against his own well-being, "Oh exquisite moment, you are so beautiful." So it is with patients who hope for optimal health, and for doctors seeking to restore optimal health when they are confronted with the paradox that treatment is traumatic, that recovery costs energy, that degeneration, decay, and death are everyone's ultimate reward. The admonition is clear. To seek unrealistic goals in therapy is destructive; too much treatment is unrewarding; obviously compromised function may be the ideal objective.

My message is, then, let us look at the processes of deterioration and disease and explore the mechanisms of repair, recovery, adjustment, and compromised function.

In summary, relative to equilibrium, one could say the diagnosis of diseases of the oral structures in the aging patient requires a careful history of the systemic and psychologic disorders of the patient. Systemic disorders may not only present oral symptoms, but may also potentiate the manifestations of dental disease. Changes in oral structures can appear in the teeth, the investing periodontium, in the alveolar bone, in the mucosa, the residual maxillary and mandibular alveolar structures, the temporomandibular joint, and the neuromuscular mechanisms which regulate mandibular motion and occlusion. The degenerative process can affect the oral tissues directly by interfering with the metabolism of the cells, or indirectly by disturbing the organ system functions of muscles and skeleton. It thus affects the dynamic equilibrium of the forces required to maintain the dental occlusion.

#### PATTERNS OF NORMALCY

There is a compelling need to conclude this paper with a discussion of normalcy. The inadequate concepts of normalcy are brought into glaring focus when one considers that the objectives for therapy for a disease state are generally directed toward recovery to a statistical norm, plus or minus the standard deviation for any known description of structure or function. This statistical norm, which is not specific for any given patient, may indeed be for him a disease-inducing state. In fact, many patients suffer from iatrogenic disorders related to the nonspecific objectives of the treatment of a given disease. In short, in the practice of dentistry patients can suffer more from the treatment than from the original disease process.

What is required, then, if our system of normative data is often inappropriate? I suggest that what is now intuitive for practitioners be developed into a systematic diagnostic and therapeutic practice. I propose that for each patient a unique hypothetical norm be evaluated and therapy be directed to this end. This will require that more indices of health in its relation to disease be examined. Figure 57 presents a schema for organizing the spectrum of knowledge appropriate to diagnosis and treatment.

Feinstein (1970) has postulated that a new basic science approach to clinical research must focus on the problem that physicians and statisticians

have committed major blunders in identifying the range of normalcy. They have not distinguished the statistical concepts of normal which are based on a patient's location on a curve of frequency distribution from epidemiological concepts drawn from an inadequate range of diversity in the investigated population, from the clinical concepts of normalcy that relate to the occurrence or future development of ill health.

He continues, "Most of our currently stated ranges of normal are grossly inadequate because the population under surveillance was usually restricted to healthy people working in the hospital where the test is developed."

Thus I propose that, for each patient, statistical norms be used merely as a guide which is scanned to locate the general area of the objective findings about the patient. And then, second, a system of functionally related criteria which holds a patient's processes of health and disease in equilibrium or in homeostasis, should be hypothesized for each treatment sequence as his provisional normal objective. Continuous reconfirmation of diagnosis and treatment response is needed. This goal having been reached, a patient's

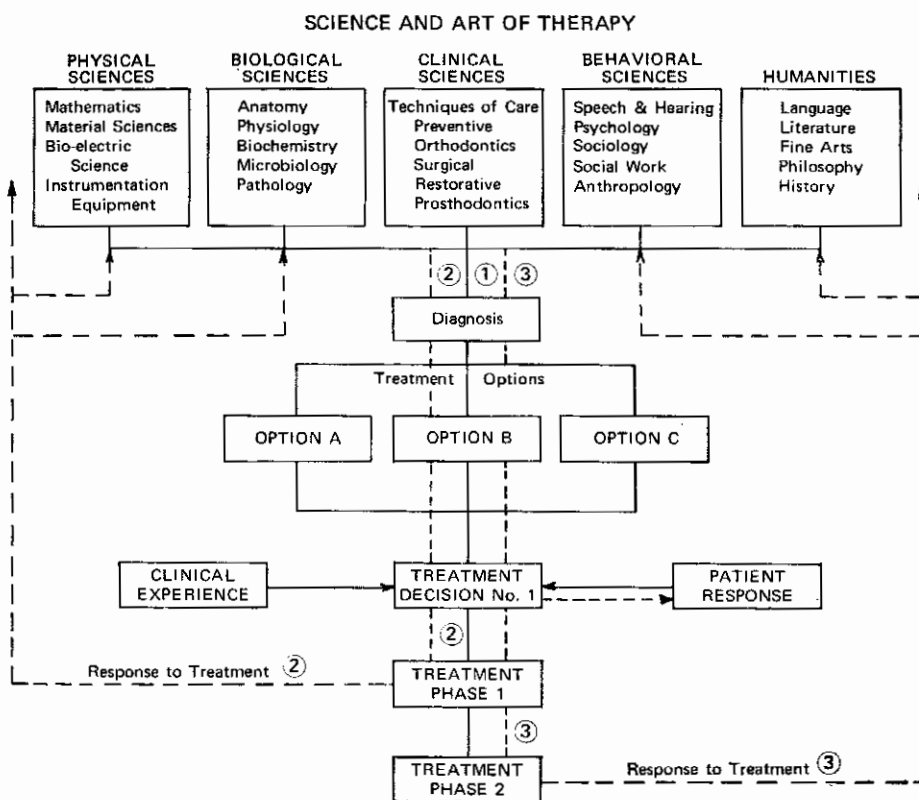

FIGURE 57. Schema for correlating the spectrum of knowledge in science and the arts appropriate for the processes of diagnosis, treatment, response to treatment, and reconfirmation of diagnosis and treatment plan.

constellation of pathophysiological adjustment must be reassessed and either the provisional norm be reconfirmed on a new level of equilibrium or a new level of equilibrium be hypothesized.

#### SUMMARY

I have reviewed in part, some of the biologic bases against which dental disease may be examined. I have given some instances where one can take physiological processes and exploit them more fully in the development of therapeutic procedures or even for exploring problems for research. Most significantly, I have directed our attention toward viewing degeneration as an adjusted state of health. It may be a good adjustment or a poor adjustment. Finally, I have suggested that we take another look at normative phenomena. I wish to suggest that the statistical norms be supplemented with the second value system unique to each patient—an individualized hypothetical norm which is appropriate to the condition surrounding the uniqueness of the events in a patient's life at any given time.

#### ACKNOWLEDGMENT

This report was supported in part by Grant No. 57-T-70 from the Social Rehabilitation Services Administration, Department of Health, Education, and Welfare.

#### REFERENCES

- FEINSTEIN, A. R., What kind of basic science for clinical medicine. *New eng. J. Med.*, **283**, 847-852 (1970).
- LITVAK, H., SILVERMAN, S. I., and GARFINKEL, L., Oral sterognosis in dentulous and edentulous subjects. *J. pros. Dent.*, **25**, 139-151 (1971).
- SHERMAN, H., Phonetic capability as a function of vertical dimension in complete denture wearers—A preliminary report. *J. pros. Dent.*, **23**, 621-632 (1970).
- SILVERMAN, S. I., Displacement patterns of posterior palatal seal. *J. pros. Dent.*, **25**, 470-488 (1971).
- SILVERMAN, S. I., The burning mouth syndrome—Restorative and prosthodontic treatment. *N.Y. st. dent. J.*, **33**, 459-466 (1967).
- STORCH, G., SILVERMAN, S. I., and LANDA, L., A cineradiographic study of normal incompetent palate subjects during deglutition. *IADR Prog. Abstr.*, **98**, 245 (1965).
- WEISS, P. A., *Dynamics of Development: Experiments and Inferences*. New York: Academic (1968).

SOME NEW TECHNIQUES FOR MEASURING  
THE BIOMECHANICAL EVENTS OF  
SPEECH PRODUCTION:  
ONE LABORATORY'S EXPERIENCES

THOMAS J. HIXON

*Speech Research Laboratory, Neurological and Rehabilitation Hospital  
University of Wisconsin, Madison, Wisconsin*

The human speech production apparatus is a remarkably engineered machine. Its function, at least from a mechanical viewpoint, is seemingly unequaled in complexity when compared to other learned motor skills that most of us perform routinely. Attempts to comprehensively analyze speech function in mechanical terms must bring to bear information on the structure of the speech apparatus, the muscular and nonmuscular forces applied to and by its various parts, and the movements of those parts as manifested geometrically and through volume and flow events (Hixon, in press). The variety of information required for such an analysis, together with the variety of body parts constituting our speaking machinery, demand that we have a substantial armamentarium of techniques for evaluating the mechanical events of speech. I have been asked to focus this paper on recent additions to this armamentarium, additions that are of importance to the study of both normal and disordered speech production. Because space limitations require that I be selective, I have chosen to emphasize new techniques that, with one exception, are currently being used in our own laboratory at the University of Wisconsin. Even with this provincial restriction, space dictates that I discuss only a few of our laboratory's recent developments, and even those not in much detail. The majority of techniques I have chosen to discuss reside in custom-designed prototype or first-generation instrumentation systems whose development has been directed toward the ends of providing (1) precision in measurements, (2) minimum or no encumbrances to the natural speech production process, (3) minimum hazards to those being studied, and (4) real-time data. The primary focus here will be on the techniques themselves and the nature of the information that can be obtained from their application. Measurement principles will be emphasized and little attention will be devoted to conventional hardware items in the various systems. Calibration procedures will not be considered.

It is beyond the scope of this paper to consider specific data; however,

many new insights about the speech production process have already been gained through use of some of the techniques to be considered here. Many of these techniques are being used routinely in our laboratory in the evaluation of organically based speech disorders. Our general approach is to apply the techniques to the study of normal speakers, and, while acquiring data on normal function, to use those data as a reference against which to compare disordered speakers. This turns out to be an excellent exchange between two major areas of study, since the study of the abnormal often tells us as much about normal function as the study of the normal contributes to our understanding of the abnormal. It will be obvious to the reader that at this time some of the techniques are more clinically applicable than others. Our own clinical applications of the techniques, while beyond the restricted aim of this paper, will be detailed in a forthcoming article (R. Netsell and T. Hixon, in preparation). We shall begin now with a discussion of respiratory measurements and then move on to the larynx and oral-facial complex, devoting roughly equal attention to each category. The general areas to be discussed include the following:

- I. Volume-Pressure Body Plethysmography
- II. Plethysmographic Measurement of Alveolar Pressure
- III. Body-Surface Measurements
- IV. Partitioning of Mechanical Forces: The Diaphragm as an Example
- V. Forced Oscillation Procedures: The Study of Laryngeal Mechanics as an Example
- VI. Strain-Gauge Measurements of Articulatory Events: Motion and Force
- VII. Electromagnetic Measurements of Articulatory Motions
- VIII. Upper Airway and Transglottal Flow Measurements
- IX. Simultaneous Measurements of Alveolar Pressure and Transglottal Flow: Variations on Two Themes
- X. Ultrasonic Scans of the Tongue
- XI. Laser Holographic Interferograms: The Study of Speech Movements.

#### VOLUME-PRESSURE BODY PLETHYSMOGRAPHY

In the respiratory pump, the net displacements of structures become expressed as volume changes. Volumes displaced by pulmonary structures of the pump are reflected in equivalent volume displacements of the body surface, since the chest wall is essentially incompressible. It is possible, therefore, to measure changes in lung volume through procedures which provide information on the volumes displaced by the body surface (Mead, 1960). Information of this nature is important in the study of speech physiology, primarily because many of the mechanical events of speech breathing are lung-volume dependent. One of the principal methods we use for measuring lung volume changes during speech is illustrated schematically in Figure 1. There, a



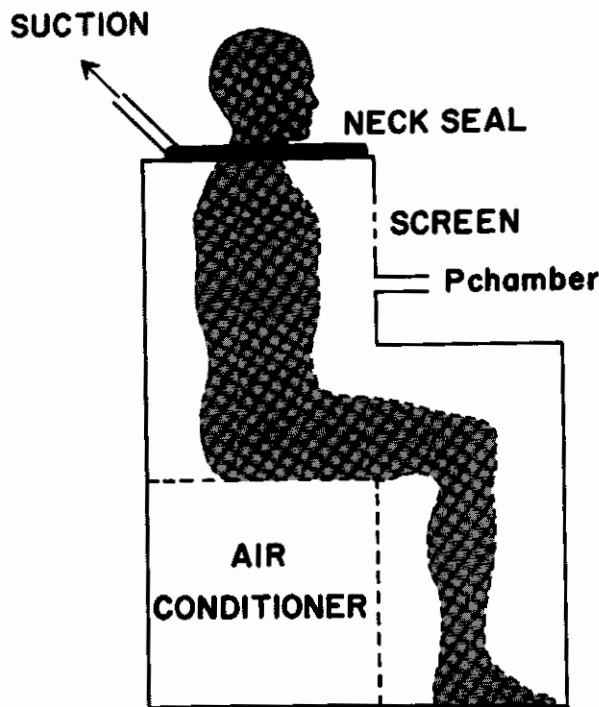

FIGURE 1. Body chamber configuration for making plethysmographic measurements of changes in lung volume during speech.

## VOLUME - PRESSURE BODY PLETHYSMOGRAPH

subject is seated inside a multipurpose wooden body chamber,<sup>1</sup> which, in this instance, is configured as a volume-pressure body plethysmograph (Mead, 1968). As shown, the subject is totally encased, except for his head and neck, which protrude through the top of the chamber. The lower part of the neck is encircled by a collar made of rubber dental dam and filled with tiny glass bubbles. This collar is shaped on each subject to provide an airtight seal between the chamber outlet and the neck; it is then hardened by active suction (Mead and Collins, 1954). An adjustable air-conditioner recirculates air within the chamber to keep the subject comfortable. As the subject performs breathing activities, chamber pressure increases with net inspiratory volume changes and decreases with net expiratory volume changes. As these volume changes occur, gas is displaced through a fine metal screen built into the

<sup>1</sup>Our chamber is custom-designed for speech research and incorporates into a single system the functional features of several systems developed as prototypes for research on respiratory mechanics. Jere Mead, Professor of Physiology, Harvard School of Public Health, introduced me to the prototype systems during a two-year visit to his laboratory as a Research Fellow, and he made many useful suggestions that are incorporated as design features in our present chamber.

front wall of the chamber. This screen acts as a linear flow-resistance so that the flow through it is directly proportional to the pressure differential between the chamber and atmosphere (P chamber). For slow changes in lung volume, essentially all of the volume change is included in the gas displaced through the metal screen. When rapid events are involved, however, part of the lung volume change goes into gas compression or expansion. No matter how rapid the volume events, all of the volume change can be taken into account at every instant by knowing the volume displaced through the screen and the volume change associated with gas compression or expansion. A measure of the volume displaced in and out of the chamber can be obtained by integrating the flow-proportional pressure signal sensed by a pressure transducer attached to the plethysmograph. Conveniently, the same chamber pressure signal provides a measure of the volume displacement related to gas compression or expansion (Mead, 1968). Since the total volume displacement is the sum of that related to gas compression or expansion and that related to displacement of gas in and out of the chamber, a measurement of the true lung volume change can be achieved by summing these two electronically (Grimby et al., 1968). Under the circumstances described, the accuracy with which rapid changes in lung volume can be recorded during speech is limited only by the response of the transducer selected and the speed of sound in air (Mead, 1968).<sup>2</sup> The system discussed here, then, meets the frequently raised criticism against using body plethysmographs in speech research (Lubker, 1970)—namely, that the response of such systems is too poor to permit accurate measurement of the volume events associated with rapid speech movements. Furthermore, the present method is more accurate than techniques which try to measure lung volume changes at the mouth during speech (Hardy and Edmonds, 1968), since volume recordings at the mouth (1) neglect lung volume changes due to gas compression or expansion (Agostoni and Mead, 1964), (2) include volume displacements not only of the lungs but also of the articulators, which themselves displace volumes during speech (Gilbert and Hixon, 1969), and (3) require that corrections be made to account for water vapor temperature changes in the gas (Collins, 1957). Finally, it is important to note that, since the subject's head is unencumbered in the present approach, there are no problems in making accurate acoustic recordings or of interfering with natural speech articulation as is the case in procedures that require the subject to be coupled to a mouthpiece or face-mask of some type (Hardy and Edmonds, 1968; Lubker, 1970).

#### PLETHYSMOGRAPHIC MEASUREMENT OF ALVEOLAR PRESSURE

The speech apparatus is a three-dimensional (acoustic) system whose

<sup>2</sup>Although our major concern in this section is with lung volume events, similar considerations about measurement accuracy, of course, apply to rates of volume change (flows) and volume accelerations. These latter two can be obtained as the first and second derivatives of lung volume change, respectively.

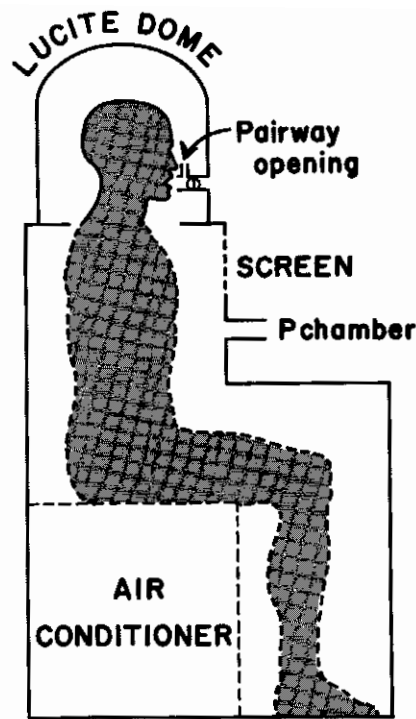

FIGURE 2. Chamber configuration for making plethysmographic measurements of alveolar pressure ( $P_{alv}$ ) during speech.

### $P_{alv}$ CONFIGURATION

net unbalanced forces are manifested in the form of pressures. Nearly continuous pressure fluctuations occur within the apparatus during speech, there being several regions along the airways where pressure measurements are especially telling of physiological mechanisms. Alveolar pressure is of particular interest in mechanical analyses of speech, since it represents the instantaneous net sum of all muscular and nonmuscular forces contributing to the respiratory driving pressure (DuBois, Botelho, and Comroe, 1956). Figure 2 schematically illustrates a method we use to measure alveolar pressure events during speech (Hixon and Warren, 1971). There our multipurpose chamber is configured without a neck seal and with a hinged, lucite dome swung down over the subject's head and latched hermetically to the top of the chamber. Recall, from the foregoing discussion, that during lung volume measurements the subject's airway opening was connected to the outside of the chamber (that is, was free to the room). Volume changes measured under such circumstances are due both to the compression (and decompression) of gas within the subject and to the displacement of gas by the subject, the latter component being of far greater magnitude than the former. In the present configuration, the subject is totally encased and his airway opening is coupled at different times during measurements either to a closed valve or to the inside of the chamber (it is in free communication with the chamber). In both airway-

opening conditions only the component of volume change related to gas compression (and decompression) is seen by the chamber. There is no displacement component when the subject is on a closed valve, since volume cannot be exchanged between the subject and the chamber. As for free breathing inside the chamber, the gas displaced in and out of the subject occupies the space created within the chamber by equivalent displacements of the body surface, and vice versa. The essence of alveolar pressure measurement via our approach is to determine alveolar pressure changes from values of compressional (and decompressional) volume changes as measured with the plethysmograph (Arutjunjan, Granstrem, and Kozhevnikov, 1967; Hixon and Warren, 1971). Such an approach capitalizes on the compressible nature of gas contained within the lungs and airways and the potential for quantifying the pressure-volume behavior of that gas through Boyle's law. In practice, measurements are made by first having the subject open his glottis and alternately compress and expand the gas within him by attempting to pant slowly through a mouthpiece against a closed valve at his airway opening. During this maneuver, simultaneous measurements are made of compressional volume changes and airway pressure changes. The former are accomplished as in volume-pressure body plethysmography (see above), the latter by a pressure transducer attached to a side tap on the mouthpiece. Because pressure is equal throughout a static fluid system, the pressure measured at the mouthpiece during compressional changes is also a measure of alveolar pressure at every instant. By relating airway pressure changes to volume changes measured at the body surface, a calibration is established which enables volume measurements to be used as measures of alveolar pressure at the absolute lung volume of concern. So calibrated, the subject comes off the mouthpiece-valve assembly, maintains the prevailing lung volume momentarily, and then speaks into the free space of the chamber. Where lung volume displacements are relatively small, such as for short utterances, only a single pre-utterance calibration maneuver needs to be performed. Utterances encompassing larger segments of the vital capacity require calibrations both before and after utterance to account for the changing calibration factor with changes in absolute lung volume (Hixon and Warren, 1971). Where large absolute lung volume changes are involved, an alternate means of calibration adjustment is on-line correction of the plethysmographic volume signal by adding to it an electrical signal proportional to the subject's instantaneous absolute lung volume (Finucane et al., 1970). Whatever the approach to calibration, once the subject is off the mouthpiece-valve assembly, the volume changes recorded by the plethysmograph represent real-time alveolar pressure measurements. Such measurements can also be taken as excellent approximations of subglottal pressure events during speech. This is possible because the impedance from the alveoli to the subglottal space (that is, along the lower airways) is sufficiently low to cause only a small pressure loss between the two regions (Bouhuys, Proctor, and Mead, 1966; Hixon and Warren, 1971). If highly accurate subglottal pressure estimates are required, this small impedance loss can be taken into account, although it appears to be an unimportant correction for most speech

research purposes. Contrasted with other available techniques for estimating subglottal pressure (Van den Berg, 1956; Draper, Ladefoged, and Whitteridge, 1959; Kunze, 1964; Perkins and Koike, 1969), the technique discussed here appears to hold several distinct advantages, the most important being that it (1) involves no discomfort for the subject, (2) presents no risk to the subject, (3) does not require the placement of measuring devices inside the body, and (4) does not require the assistance of a physician. Such advantages are of obvious interest to both the investigator and the subject, the first three being of heightened significance in the case of neurological patients where other procedures are generally impractical and often intolerable.

#### BODY-SURFACE MEASUREMENTS

From a functional perspective, the chest wall can be viewed as a two-part mechanical system, the parts being the rib cage and diaphragm-abdomen (Konno and Mead, 1967). Each part moves basically as a unit during speech, although there exists a substantial potential for independence of motion between the two. Witness to the latter is the ability to change lung volume mainly with either the rib cage or the diaphragm-abdomen, and the ability to produce paradoxical movements of one or the other of the subdivisions during breathing maneuvers. As each part moves during speech and displaces volume, points within the part go through motions that are uniquely related to the volumes displaced. More specifically, the volumes displaced by either the rib cage or the abdomen are essentially linearly related to the linear motions of points within the respective parts (Konno and Mead, 1967; Peyrot, Hertel, and Siebens, 1969). We take advantage of this relationship and estimate the separate volume displacements of the rib cage and abdomen during speech by measuring the anteroposterior diameter changes of the two parts (Hixon, Mead, and Goldman, 1970). As in total lung volume change during speech, measurements of the separate volume displacements of the rib cage and abdomen are important because many of the mechanical events within these subdivisions of the respiratory pump are volume-dependent (T. Hixon, M. Goldman, and J. Mead, in preparation). Measurements are accomplished along the lines illustrated in Figure 3. Changes in the diameter of the rib cage and abdomen are generally measured at the torso midline and at the levels of the nipples and slightly above the umbilicus, respectively. In our laboratory these measurements are made through the use of either of two transducer systems: the magnetometers (Mead et al., 1967) depicted in panel (a) of Figure 3 or the variable inductance linear displacement transducers (French, 1966) portrayed in panel (b). The magnetometer system consists of two pairs of coils, each pair having a coil to generate a magnetic field and an identical mate to sense the field generated. Distance changes between the mates (that is, diameter changes in the respiratory part of interest) are indicated by voltages induced in the sensing coil, with the magnitude of the voltage being inversely proportional to the cube of the dis-

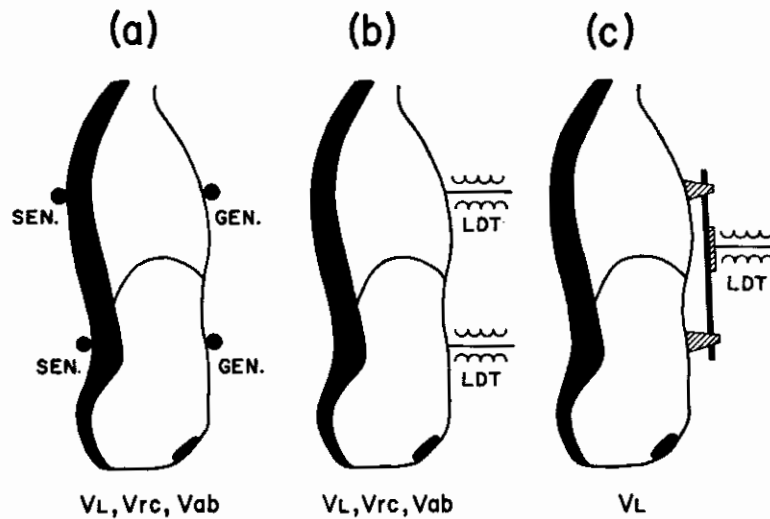

FIGURE 3. Methods for measuring changes in lung volume ( $V_L$ ), rib cage volume ( $V_{rc}$ ), and abdominal volume ( $V_{ab}$ ) from body surface movements during speech. (a) four-coil magnetometer system; (b) two linear displacement transducers; (c) a single linear displacement transducer and a rigid strut.

tance between the two coil mates. Because the range of torso motions encompassed during most speech is small compared to the absolute intercoil distances, the relationship between induced voltage change and diameter change is nearly linear. The linear displacement transducers we use are electromechanical devices custom built in our laboratory. Each of these transducers indicates with a relative DC output voltage the position of a point in reference to a fixed point in line with the axis of the device. A simple way to conceptualize the action of the devices is to consider their two coils as forming voltage dividers. As a ferrite armature is passed through the center of the coils, the relative inductance and, therefore, the impedance of each coil changes. The result is an output voltage that varies directly and linearly with the position of the armature. The armature itself is made of ferrite tubing attached to a spring-loaded fiberglass rod that is placed directly on the surface whose displacement is to be sensed. Although the results obtained with the magnetometer and displacement transducer systems are basically identical, the displacement transducer system is somewhat more difficult to use because the subject must maintain relatively stable posture against a back support. During measurements with the magnetometer system, the subject is permitted much greater freedom of movement. From data on the changes in anteroposterior diameter of the rib cage and abdomen, not only are the separate volume contributions of the two functional parts of the chest wall known, but it is also possible to determine the change in total lung volume during speech by summing the two diameter signals graphically or electronically (Hixon, 1970). Electrical summation results in a signal that

over a wide range of lung volumes is a practical equivalent of the volume events measured by more conventional techniques (Mead et al., 1967). A variation on the theme of measuring lung volume changes from body surface movements is illustrated in panel (c) of Figure 3. There a simple mechanical device and a single linear displacement transducer are used to obtain data on lung volume changes during speech. Since the chest wall is functionally a two-degree of freedom system, the displacements of the rib cage and abdomen can be resolved into a single displacement that is proportional to lung volume change (Peyrot et al., 1969). This is easily accomplished by running a post between the rib cage and abdomen and finding the point on this post which does not move during voluntary shifting of volume between the two parts of the system (the rib cage and abdomen) under isovolume conditions (that is, with the glottis closed). Once the location of this point is determined empirically, measurement of the displacement of the point during breathing or speech activities provides another means of recording total lung volume changes. Thus, without interference to acoustic recording or encumbrance to the natural speech articulation process, the techniques discussed in this section enable us to measure changes in the separate volumes of the rib cage and abdomen, and in the total lung volume during speech. The advantages discussed earlier for plethysmographic recording of volume events during speech over volume recordings at the airway opening also apply as advantages of these techniques.

#### PARTITIONING OF MECHANICAL FORCES: THE DIAPHRAGM AS AN EXAMPLE

Like many other complex machines, the behavior of the speech production apparatus is governed by the actions of a number of different mechanical parts. Since the actions of these parts are influenced by both muscular and nonmuscular forces, it is important to the understanding of speech mechanics to be able to partition these forces during measurements. One of the approaches we use for obtaining information on the forces regulating the behavior of one of these parts—namely, the diaphragm—is illustrated schematically in the upper part of Figure 4. The strategy there is to combine two measurement techniques, one to provide information on the electrical activity of the muscular portion of the diaphragm (Hixon, Minifie, Peyrot, and Siebens, 1968) and the other to provide information on the structure's transmural pressure (Agostoni and Rahn, 1960; Bouhuys et al., 1966). The electrical activity of the diaphragm is sensed by an EMG electrode of our own design (Hixon, Siebens, and Minifie, 1969). This electrode, shown in the lower part of Figure 4, is a bipolar surface unit that is passed pernasally into the esophagus and positioned at the level of the esophageal hiatus. The distance between the poles of the electrode (that is, the two silver spheres) is adjusted to obtain optimal recordings and then the electrode is anchored in the hiatus through inflation of a gastric balloon attached to the unit. In the

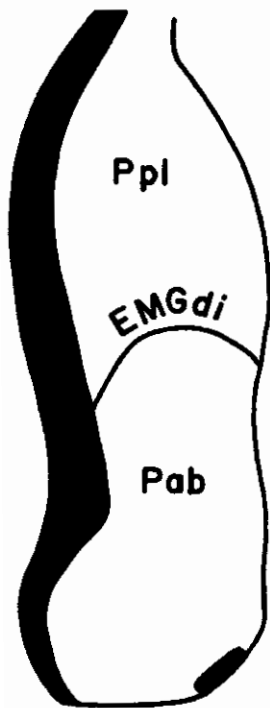

$$Ppl - Pab = Pdi$$

FIGURE 4a, b. Left (4a): Factors influencing diaphragmatic behavior during speech. Ppl = pleural pressure. Pab = abdominal pressure. EMGdi = electromyographic activity of the diaphragm. Pdi = transdiaphragmatic pressure. Below (4b): Miniature pressure transducers for obtaining estimates of Ppl and Pab, and a bipolar surface electrode for sensing the electrical signal from the diaphragmatic crurae.

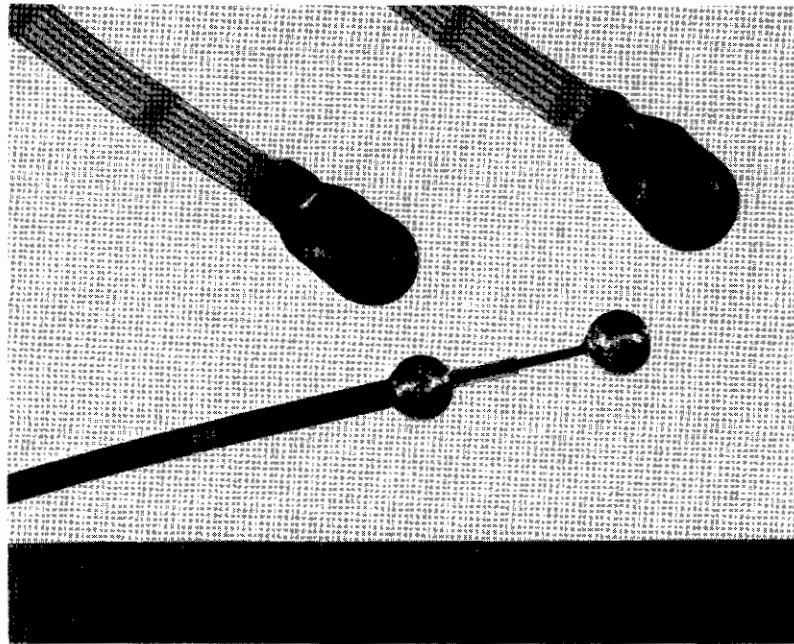



hiatus, the electrical activity of the crurae (pillars) of the diaphragm is sensed, activity which is comparable to that of the more major muscular portions of the structure (the costal fibers) (Hixon et al., 1969). With the electrode in position, the nearest skeletal muscles, other than the diaphragm, are the psoas and quadratus lumborum. Since hip flexion maneuvers do not modify the electromyogram, it seems highly unlikely that recordings could be contaminated by electrical activity from these or other more distant muscles. In addition to being recorded in its raw form, the EMG signal from the crurae is electronically conditioned through custom-built instrumentation which accomplishes a real-time elimination of the electrocardiogram interference and provides a voltage equivalent of the first integral of the raw signal (French and Siebens, 1969). To measure transmural pressure, simultaneous recordings of esophageal and gastric pressures are made using recently improved conventional latex balloon techniques (Milic-Emili et al., 1964) or using the miniature pressure transducers shown in the lower part of Figure 4 (Hixon, Minifie, Peyrot, and Siebens, 1968). The latter are commercially available sensors with excellent frequency response, although in some regards they are less desirable to work with and less accurate than balloon procedures.<sup>3</sup> Whichever sensing system is used, the devices are passed pernasally, one to the level of the middle third of the esophagus and the other into the stomach. The pressure recorded from the esophageal unit is taken as a measure of pleural pressure (Mead and Milic-Emili, 1964), and the gastric pressure signal is used to estimate abdominal pressure (Agostoni and Rahn, 1960). Gastric and abdominal pressures actually differ by an amount dependent upon the muscle tone of the stomach and the hydrostatic pressure gradient between the pleural surface and the stomach (Duomarco and Rimini, 1947). To a close approximation, the magnitude of this difference is indicated by the minimum difference between gastric and pleural pressures during relaxation above the resting expiratory level (Bouhuys et al., 1966). This difference is subtracted from the gastric pressure to correct it to abdominal pressure. As portrayed in Figure 4,

---

<sup>3</sup>One inconvenient aspect of using miniature pressure transducers is the difficulty in zeroing them to atmosphere once they are in position within the esophagus or stomach. Other problems relate to the temperature sensitivity of the devices. They must be calibrated at the temperature at which they will be operating during measurements in situ. We do this in a water bath heated to the subject's body temperature, which is in the neighborhood of 37°C. In situ temperature variations also affect measurements; however, these are negligible for measurement purposes within the esophagus and stomach. In applications where the transducer is placed in a flow stream (for example, in the mouth), flow-induced temperature changes render the use of the devices difficult. Finally, it should be recognized that esophageal pressure (Pes) measurements made with miniature transducers reveal local variations in pressure. Esophageal balloons, on the other hand, when encompassing a region of the esophagus where pressure is not uniform from point to point, will provide a measurement of pressure that approximates the most negative value in the region (Mead and Milic-Emili, 1964). Since it is the most negative value of pressure that is usually most significant from a mechanical perspective, the esophageal balloon would be preferred. Indeed, although miniature pressure transducers provide some advantages in size and frequency response, and perhaps even durability, the nature of the measurements to be made dictates whether they are reasonable substitutes for standard esophageal balloon techniques.

since the pressure acting on the pulmonary side of the diaphragm (the pleural pressure) as well as that acting on the abdominal side of the partition (abdominal pressure) can be specified, the transmural or transdiaphragmatic pressure acting on the structure at every instant can be designated (Bouhuys et al., 1966). By knowing the pressure differential across the diaphragm together with its own electrical activity, one can analyze the net forces regulating the structure into components of both muscular and nonmuscular origin (Hixon, Minifie, Peyrot, and Siebens, 1968). A typical approach to such an analysis would be first to have the subject relax his respiratory pump against an infinite resistance at different lung volumes throughout his vital capacity while simultaneously recording electrical activity and transdiaphragmatic pressure. Then by relating the electrical and pressure signals recorded during speech to those recorded during relaxation, it is possible to interpret departures from relaxation data as activity of either muscular or nonmuscular origin. In fact, combining data from such techniques with data on the separate volume changes of the rib cage and abdomen (Hixon, Minifie, Peyrot, and Siebens, 1968) allows us to make reasonable inferences concerning the nature of muscular activity—namely, whether it is isotonic, isometric, or pliometric. Aside from the unique mechanical information that the procedures described here provide, techniques of this type have the obvious advantage over x-ray procedures that they permit extensive study of the part in question without hazard to the subject. The discussion here has considered the study of diaphragmatic behavior only. The principles involved, however, have general applicability to the study of many other parts of the speech production apparatus (Hixon, Siebens, and Ewanowski, 1968).

FORCED OSCILLATION PROCEDURES:  
THE STUDY OF LARYNGEAL MECHANICS  
AS AN EXAMPLE

Forced oscillation techniques are a new and powerful approach to the study of the mechanics of speech and voice production. These techniques involve a wide variety of forced applications of either known pressure or volume changes to various parts of the speech apparatus. The results of such applications can be interpreted in terms of changes in the behavior of these parts, or in terms of changes in various aspects of the acoustic signal. For purposes of discussion here, we will consider only one of the many possibilities for applying forced oscillations in speech research, the application of forced transglottal pressure changes in the study of the mechanics of voice production. One of the approaches we use is to apply forced sinusoidal pressure oscillation to the body surface (Hixon, Klatt, and Mead, 1970). Figure 5 illustrates this approach schematically. There a subject is seated in our multipurpose chamber, which is configured in this instance as a pressure-oscillation device. The subject's head and neck protrude unencumbered through the top of the chamber and a loose-fitting but hardened collar encircles the subject's neck at the chamber outlet. Four loudspeakers, two series sets in parallel, are coupled to

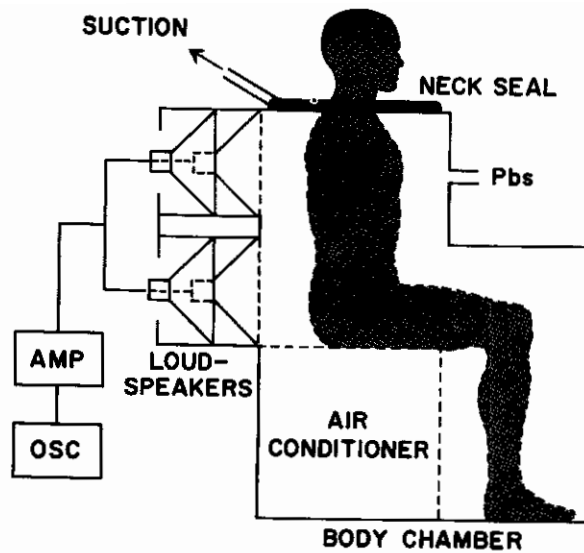
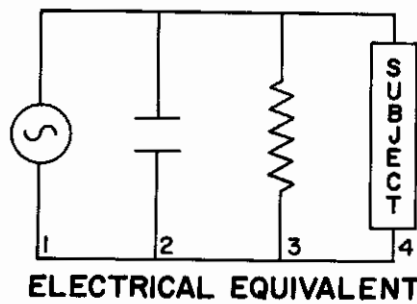

FIGURE 5. Upper: Body chamber configuration for applying forced oscillatory changes in pressure at the body surface ( $P_{bs}$ ). Lower: Electrical equivalent of the mechanical situation illustrated in the upper part of the figure. See discussion in text.



the back of the chamber and are controlled through a power amplifier by an oscillator. This chamber configuration permits sinusoidal pressure changes to be provided within the chamber (at the body surface) over a wide range of frequencies and at amplitudes of up to 6 cm H<sub>2</sub>O peak to peak. The lower part of Figure 5 depicts an electrical analogue of the mechanical situation of the chamber containing a subject. The loudspeakers (1) see in parallel the following: the gas in the chamber as a compliance (2), the leak across the loose-fitting neck seal as a resistance (3), and the subject as a complex, lumped component (4). The pressure applied to the subject during oscillation is spent in a complex fashion among opposing pressures of resistances, compliances, and inertances. At one particular frequency of oscillation, namely, the resonant frequency of the respiratory pump, opposing pressures related to inertance and compliance are equal and of opposite sign and thus cancel (DuBois, Brody, Louis, and Burgess, 1956; Grimby et al., 1968; Peslin, Ilixon, and Mead, 1971). At this frequency, the impedance of the respiratory apparatus is represented entirely by a flow-resistive term (Goldman et al., 1970). This frequency can be determined empirically in each subject by varying the frequency of applied

pressure until flow, as measured by a flowmeter at the subject's airway opening, is exactly in phase with transrespiratory pressure (that is, the pressure differential between the body surface and the airway opening). Under the conditions described, pressure changes generated at the body surface are realized as slightly smaller pressure changes at both the pleural surface and the subglottal space, since there is a small resistive pressure loss across the chest wall (Hixon, Klatt, and Mead, 1970). Thus, it is possible to impart known forced subglottal pressure changes to the larynx through the application of known forced body surface pressure changes corrected for this loss (Hixon, 1971b). In addition, it is possible to depart from the resonant frequency of the subject under certain circumstances and still have a good estimate of subglottal pressure changes from body surface pressure changes, since the high magnitude of the series resistance offered by the larynx during voice production renders the reactive components of the mechanical system relatively unimportant (Hixon, Klatt, and Mead, 1970).

Before considering the nature of the information that can be obtained about laryngeal function through the use of forced oscillation, we will discuss a second mode we use for applying forced pressure changes transglottally. This mode, shown schematically in Figure 6, involves the generation of sinusoidal pressure changes at the subject's airway opening (Grimby et al., 1968; Lieberman, Knudson, and Mead, 1969; Hixon, Klatt, and Mead, 1970). The configuration shown has the subject coupled at the mouth to the multipurpose chamber through a low resistance and low inertance tubing arrangement. A

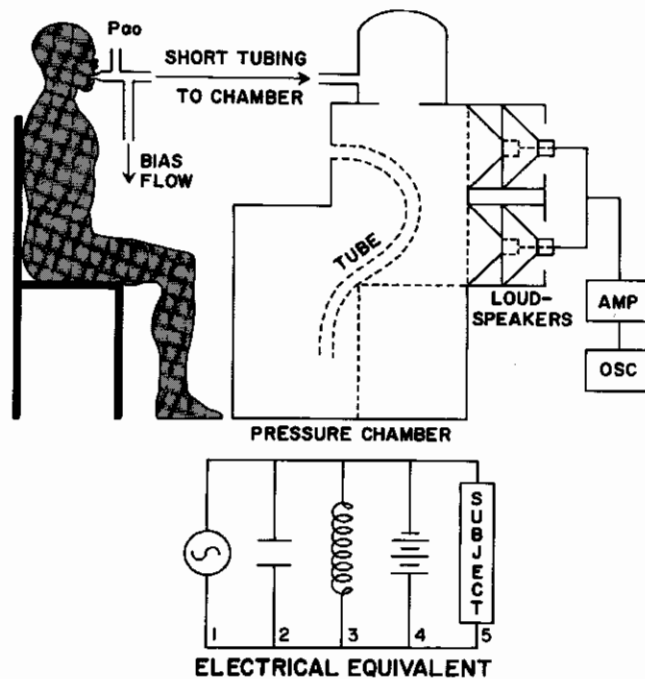

FIGURE 6. Upper: Chamber configuration for applying forced oscillatory changes in pressure at the airway opening ( $P_{ao}$ ). Lower: Electrical equivalent of the mechanical situation illustrated in the upper part of the figure. See discussion in text.

bias flow of constant magnitude is used to circulate air through the system and, thereby, reduce dead space. A long tube within the chamber and with one end to atmosphere accommodates the needed vent for the bias flow and for breathing and, at the same time, offers high inertial impedance at the frequencies of oscillation used for experimental manipulation. This latter feature makes it possible to develop the desired pressure levels within the chamber, despite the substantial vent leak (Grimby et al., 1968). The entire setup is so arranged that changes in the mechanical impedance of the subject (for example, increases in laryngeal impedance) have little influence on the pressure delivered at the airway opening. The bottom of Figure 6 shows the electrical equivalent of the mechanical situation depicted in the top of the figure. In this case, the loudspeakers (1) see in parallel the following: the gas in the chamber as a compliance (2), the gas in the long tube as an inertance (3), the DC bias flow as a battery (4), and the subject as a complex, lumped component incorporating compliances, resistances, and inertances (5). As with the body surface configuration, control of the four loudspeakers through an oscillator and power amplifier enables one to regulate chamber pressure and, thereby, permits variation of the pressure seen on the downstream (supraglottal) side of the larynx. Thus, with either of the two techniques discussed, it is possible to impose forced transglottal pressure changes, with these changes being applied to the pulmonary side of the larynx in the one case and to the upper airway side in the other.

With the capability for providing controlled changes in pressures acting on the larynx, we are in a position to study the influence of transglottal pressure events on various acoustical aspects of voice production and on the mechanical behavior of the laryngeal valve. Most of the information gathered to date has been obtained through application of forced oscillations while speakers phonate sustained vowels (Lieberman et al., 1969; Hixon, Klatt, and Mead, 1970). It is assumed that during such utterances, vocal fold adjustment remains constant so that changes in vocal output are attributable solely to variations in transglottal pressure. Although laryngeal electromyography must eventually be consulted in this regard, the observation that DC pressure and flow do not change when going from normal phonation to phonation under oscillation conditions suggests that contributory laryngeal adjustments are not made during oscillatory applications. Forced oscillation procedures, therefore, provide a means for partitioning the contribution of the respiratory pump under conditions where both the respiratory and laryngeal systems can influence various acoustical parameters of the voice (for example, vocal fundamental frequency and vocal intensity). These techniques, in addition, provide a means for studying the mechanical behavior of the larynx in response to pressure changes, that behavior being revealed in part through pressure-flow measurements during phonation. In this regard, it should be noted that oscillatory resistance measurements (Peslin et al., 1971) can be made during phonation without inserting various devices within the body to estimate subglottal pressure. Comparing our two modes of applying pressure, the body surface configuration has a distinct advantage over the airway opening appli-

cation in that the subject's speech apparatus is unencumbered and, therefore, interference with natural utterance or acoustic recording is not a problem.

#### STRAIN-GAUGE MEASUREMENTS OF ARTICULATORY EVENTS: MOTION AND FORCE

Some parts of machines move and exert forces; and so it is with the articulatory machinery. To comprehensively describe articulatory function at a mechanical level, we must be able to quantify the relation of motion to force in accordance with physical laws. Such quantification allows us to gain understanding of the underlying mechanisms and properties of the speech production apparatus. The mechanical actions of the articulators are difficult to measure because of both the complexity of speech behavior and the difficulties involved in tracking rapidly moving and, in some cases, relatively inaccessible structures. Recent advances in recording technology now make it possible to obtain real-time data on the motions and forces associated with various articulator activities. Some of these advances are in the form of strain-gauge systems, several of which are now in use in our laboratory. As examples of these, we will discuss four recently developed systems and their applications to studies of the mandible, lips, and velum.

An example of strain-gauge application to the monitoring of jaw displacement is illustrated in Figure 7. The unit depicted was constructed in our laboratory (Abbs, 1971) after a prototype by Sussman and Smith (1970). The subject wears an adjustable headband and support system to which one

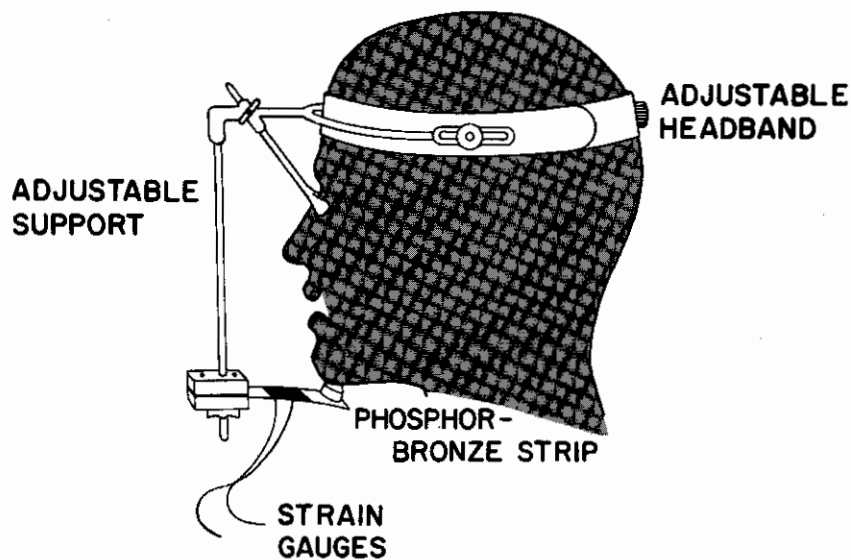

#### JAW DISPLACEMENT TRANSDUCER

FIGURE 7. Strain-gauge transducer for measuring vertical movements of the jaw during speech.

end of a phosphor-bronze strip is clamped. The other end of the strip presents an attached rubber knob that rests on the skin over the mental protuberance of the mandible such that some degree of initial strain is placed on the strip. Strain gauges are bonded to both sides of this metal strip and wired to form two arms of a four-arm Wheatstone bridge circuit. In the position shown, vertical movements of the jaw exert bending forces on the metal strip that are realized as resistance changes in the strain gauges. The result is an output voltage signal that is directly proportional to the component of mandibular motion that is resolved into the vertical dimension. Since the transducing system is fixed relative to the head, the subject is allowed reasonably free movement without risk of recording artifact. It has been shown that jaw movement transducing in this configuration is subject to negligible artifact from anteroposterior jaw movements in the range of movements characteristic of speech. More specifically, maximum jaw openings in the vertical dimension are about 5% smaller than those along the true movement path of the jaw as influenced by the temporomandibular joint articulation (Abbs, 1971). In addition to utilizing the voltage output from the transducer as an analogue of jaw displacement, most of the measurements now made in our laboratory incorporate differentiation of the voltage signal to obtain information on both the velocity and acceleration components of jaw motion (Abbs and Netsell, 1970). The latter component appears to provide information undiscernible from visual analyses of displacement tracings alone and, in fact, may well provide a means of examining the net muscular forcing function of the mandibular articulator (Abbs and Netsell, 1971).

Lip displacement during speech can be measured in a way similar to that just described for the jaw. As was the prototype of our jaw displacement transducer, the system for making lip measurements was developed by Sussman and Smith (1970) in the Behavioral Cybernetics Laboratory at the University of Wisconsin. As shown in the left side of Figure 8, this system is com-

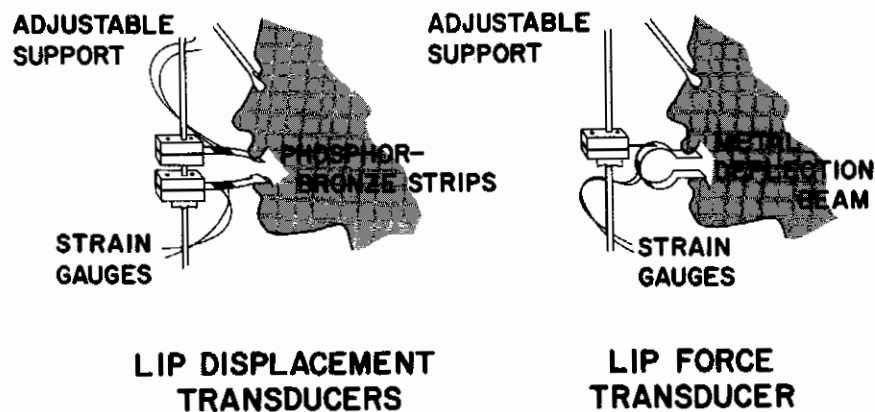

FIGURE 8. Left: Strain-gauge transducers for measuring vertical movements of the lips during speech. Right: Strain-gauge transducer for measuring the net force of lip activity during speech.

posed of two separate transducers, one for each lip. Each unit consists of a T-shaped phosphor-bronze strip with the bar portion of the T in contact with the lip. These strips are extremely flexible and present no significant interference with lip movement (Sussman and Smith, 1970). The transducers are positioned so that in a mouth-open position there is some initial strain on each strip. The resultant recoil of the metal strips and surface forces from the moist lip mucosa are sufficient in combination to keep the bars of the Ts in contact with the lips. As in the jaw transducer, pairs of strain gauges form two arms of a four-arm Wheatstone bridge for each unit, so that, when lip displacements place bending forces on the metal strips, resistance changes occur in the strain-gauge elements. The result is a changing output voltage that varies in direct proportion to the vertical displacement component of the lip being monitored. Again, as with the jaw-transducing unit, the analogue signals are in real-time and can be differentiated to determine the velocity and acceleration components of movement.

The right side of Figure 8 schematically illustrates a strain-gauge transducer recently developed by one of our students (Kim, 1971) to measure the force of lip activity. This unit provides a voltage output directly proportional to the net force generated by the activity of the two lips combined. As shown, a rigid strut supports a circular-shaped flat metal deflection beam whose ends come in contact with the upper and lower lips. The net displacement of the two lips induces a net strain on the metal beam that is reflected in the changing resistances of two strain gauges bonded to opposite sides of the circular beam. These gauges act as two arms of a four-arm Wheatstone bridge. Because the circular-shaped deflection beam is functionally similar to a spring, the net force generated by the lips in deflecting the ends of the beam is equal to the product of the spring constant and the net displacement of the beam's ends.

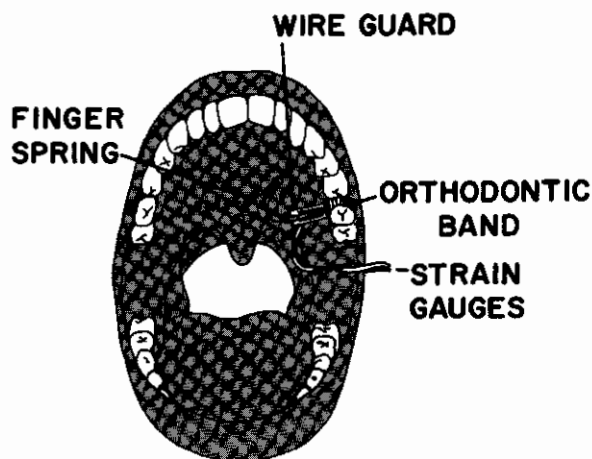

FIGURE 9. Strain-gauge transducer for measuring velar movements during speech.

### VELAR DISPLACEMENT TRANSDUCER



Within the range of displacements involved in speech, the system behaves in a manner predictable by Hooke's Law. Thus, it is possible to estimate the net force of lip activity during speech in terms of the net displacement of the two ends of the deflection beam. Although little work has yet been done with this transducer system, and although it does present some interference to labial activity, it appears to represent as good a system as is available for measuring this aspect of speech mechanics.

As a last example of strain-gauge instrumentation systems of recent origin, Figure 9 depicts a velar displacement transducer that is used in our laboratory. This unit was fabricated directly after the prototype transducer built by Christiansen (Moller and Christiansen, 1969; Christiansen and Moller, 1971; Moller, Martin, and Christiansen, 1971). The sensing unit consists of two strain gauges mounted on a cantilever beam that attaches by an orthodontic band or a tooth clip to a maxillary molar. A wire guard fixed to the assembly protects the cantilever beam inferiorly so that tongue movements will not create measurement artifacts by exerting forces on the beam. A finger-spring extends from the cantilever beam to contact the velum at the midline and at about its middle third longitudinally. Vertical movements of the velum during speech result in displacements of the finger-spring that in turn are resolved into bending of the cantilever beam. Strain gauges bonded to the beam respond to the bending forces, and, thereby, change the resistance in two arms of the Wheatstone circuit. The result, as with the other displacement devices just discussed, is an output voltage that represents velar displacement in an analogue form. Finally, as with the other techniques discussed derivatives of this signal can be taken to determine other components of motion.

#### ELECTROMAGNETIC MEASUREMENTS OF ARTICULATORY MOTIONS

In addition to measuring articulatory motions with strain-gauge transducers, we also use electromagnetic transducers called magnetometers (Mead et al., 1967; Hixon, 1971a). The general principles underlying magnetometer measurements were discussed earlier under "Body-Surface Measurements." Unlike body-surface measurements, where four coils are used, only one generating coil and either one or two sensing coils are used for measurements of articulatory motion. As an example of how electromagnetic techniques can be applied to measure articulatory motions, the left side of Figure 10 illustrates a method for measuring the vertical displacements of the mandible during speech (Hixon, 1971a). There a generating coil (encased in polyethylene) is fixed to the undersurface of the jaw with the long axis of the coil oriented perpendicular to the sagittal plane. An identically oriented sensing coil is positioned atop the head so that it cannot be moved by facial gestures. Recall from earlier discussion (see "Body-Surface Measurements") that with the long axes of the generating and sensing coils oriented parallel, the voltage induced in the sensor is inversely proportional to the cube of the distance between the

coils. Therefore, with the upper coil serving as a stable reference, vertical movements of the generating coil on the jaw induce voltage changes in the sensor and, thereby, provide a continuous real-time electrical equivalent of what may be conceptualized as the unidimensional movement of a point on the jaw. For practical purposes, this equivalent is linearly related to coil displacement, since the range of jaw motion encompassed in speech is small compared to the absolute intercoil distance. The sensing coil can be stabilized in other locations above or below the generating coil, but placement atop the head has the advantage of allowing the subject relatively free movement. Movement of the skin over the mandible results in some measurement artifact; however, the use of the generating coil on a special device attached to the lower incisors (Ohala et al., 1968) shows nearly comparable results to those obtained with the generator on the undersurface of the jaw. Additional information bearing on this point has been provided by Netsell,<sup>4</sup> who found displacement of a point on the undersurface of the jaw to agree, within a few percentage points, with vertical measurements obtained from tracings of cinefluorographic films showing displacement of the bony mandible.

The right side of Figure 10 shows a method for recording mandibular motions in two dimensions. There another sensing coil is added, this one positioned on the back of the subject's neck. Like its equivalent atop the head, the neck coil affords continuous measurement of the distance the generator is moved toward or away from it. With the two sensing coils stabilized and the gen-

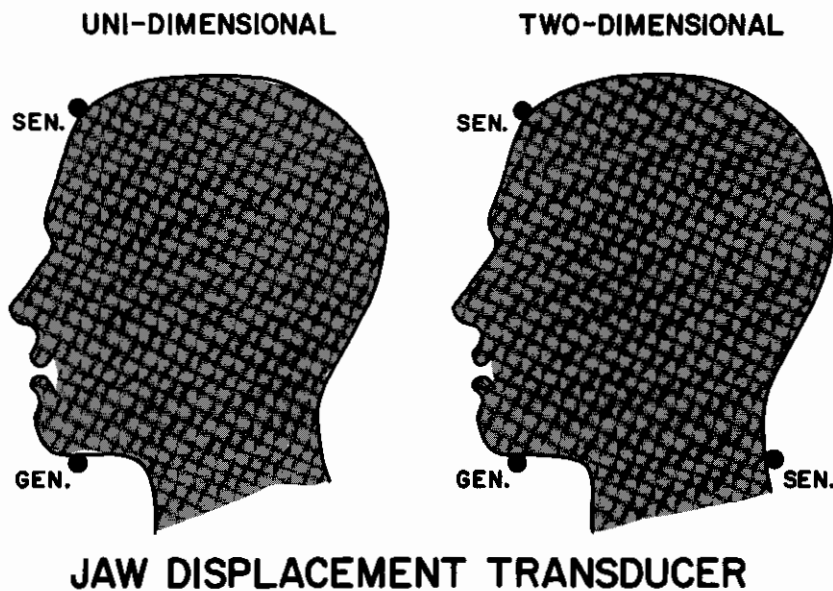

FIGURE 10. Left: Magnetometer coil arrangement for measuring vertical movements of the jaw during speech. Right: Coil arrangement for measuring simultaneous vertical and anteroposterior movements of the jaw.

<sup>4</sup>Netsell, R., personal communication (1970).

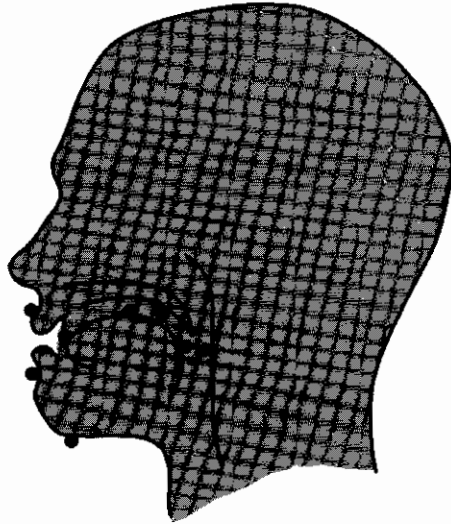

FIGURE 11. Strategic generating coil placements on the articulators where measurements with miniature magnetometers should be profitable.

## GENERATOR PLACEMENTS

erating coil riding with the mandible, simultaneous recordings of the two-dimensional movements of the generator are obtained. By displaying these two movements relative to each other, one can visualize the two-dimensional movement of a point on the jaw within the sagittal plane (Hixon, 1971a).

Attempts to measure the movements of other articulators have been encouraging; however, our present coils are too large (2 cm in length and 0.5 cm in diameter) for use within the vocal tract without significantly interfering with natural speech. We are now in the process of solving this particular problem by constructing miniature coils that are mounted on tiny suction cups that will fix the coils to intraoral structures. Figure 11 shows some of the strategic points we hope to soon be able to track in various dimensions during speech. Filled circles show locations on the lips, mandible, tongue (three points), velum, and posterior pharyngeal wall. The filled rectangle illustrates the long axis coil positioning that might be employed to study lateral pharyngeal wall movement. Of course, with the electromagnetic procedures considered in this section, we have the capability to examine both the velocity and acceleration of movements of the various articulatory structures, as we saw was the case for strain-gauge displacement monitors.

Finally, those wishing to pursue techniques based on electromagnetic principles might also consider the use of recently developed magnistors,<sup>5</sup> which are tiny magnetic-sensing transistor chips. These devices show promise of further miniaturization than may be possible with magnetometer coil systems.

<sup>5</sup>Manufactured by the Hudson Corporation, Box 867, Manchester, New Hampshire 03105.

## UPPER AIRWAY AND TRANSGLOTTAL FLOW MEASUREMENTS

An important manifestation of motion in the speech production apparatus is flow. Flow measurements are of interest in a number of locations, two of the most important of which are at the airway opening (at the mouth, the nose, or both) and transglottally (across the larynx). One of the procedures we use to measure flow from the upper airway during speech is illustrated in Figure 12. The system is a slightly improved version of a prototype system

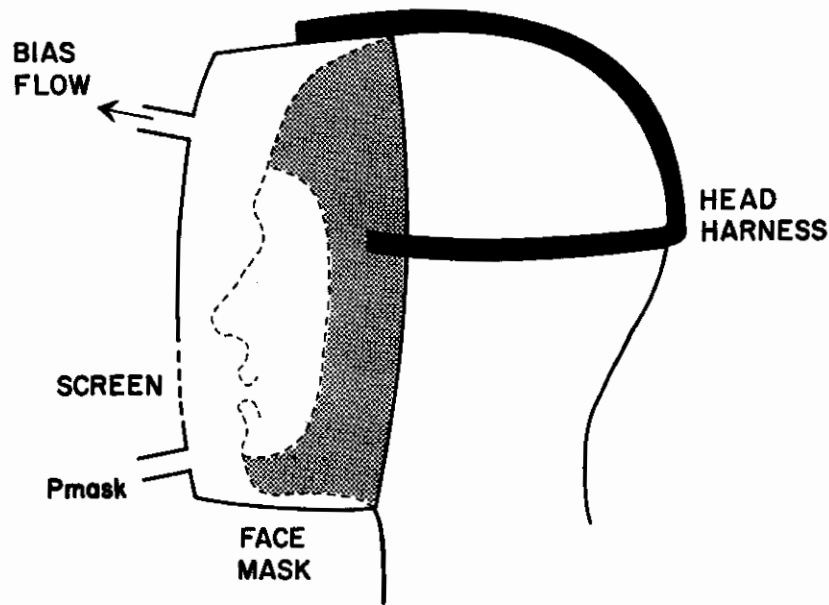

FIGURE 12. Full-face mask system for measuring flow at the airway opening ( $\dot{V}_{ao}$ ) during speech.

designed by Mead (Mead, 1960; Klatt, Stevens, and Mead, 1968). A large mask is placed over the subject's face and secured by a head harness. This mask contains a rubber diaphragm with a center opening into which the subject fits his face and which facilitates an airtight seal between the subject and the mask. The perimeter of the mask is firm but sufficiently compliant to permit the subject's articulators (including the jaw) rather free motion without significant encumbrance to natural articulation. The front wall of the mask is formed by a lucite face plate and contains a relatively large opening covered by a metal screen. This screen serves as a linear resistance to flow into and out of the mask during speech or breathing activities. A bias flow moves air at a constant rate through the mask and thereby serves several useful purposes: it prevents condensation of moisture on the metal screen (otherwise screen resistance would change), it helps to reduce dead space within the mask, and it helps to keep the subject relatively cool and comfortable. Pressure within the

mask is sensed by a transducer and taken as a measure of flow through the metal screen at every instant. Our mask is built so that a metal screen area of various sizes is available for different studies. Selection of screen size depends on the range of flows to be encountered in a given study, and is made to insure that the mask pressure signal will be linearly related to flow through the screen. The part of the mask pressure signal related to the bias flow can be taken into account as baseline offset or it can be zero suppressed electronically (Klatt et al., 1968). As the subject speaks into the mask system, flows from the airway opening are sensed along with flows related to changes in mask volume caused by displacements of various articulatory structures and the walls of the mask itself. The latter component of flow is an artifact for most measurement purposes; however, it is relatively small for most speakers and dependent upon the speech sampled. The overall system described here surmounts many of the measurement system objections that are routinely raised against the use of other types of masks for speech research (Hardy, 1965; Lubker and Moll, 1965; Hixon, 1966; Subtelny, Worth, and Sakuda, 1966; Lubker, 1970). First the present system places insignificant restriction on natural articulatory movements. Second, the bias flow feature surmounts all of the physiological objections that have been raised to the use of masks, such as problems with their dead space and discomfort for the subject. These are objections that can be met in any mask system simply by incorporating a bias flow into the system.

Techniques have not previously been available for measuring flows across the larynx during speech, except to the extent that such measurements can be made at the airway opening during utterances where the articulators are relatively stationary (for example, sustained vowels) and, therefore, are not themselves creating flows (Gilbert and Hixon, 1969). A procedure we use to circumvent the articulatory displacement problem and, thus, obtain a measure of transglottal flow, is illustrated schematically in Figure 13. The subject is seated in our multipurpose chamber, the door of the chamber being open in this configuration. Our collar is used to form an airtight seal between the subject's neck and the top of the chamber through which the subject's head and neck are protruding. A lucite dome is positioned over the subject's head and latched airtight to the top of the chamber. Together, the collar and dome form a small chamber that completely encases the speech apparatus from the larynx outward. A metal screen is built into the wall of the dome and serves as a linear resistance to flow into or out of the chamber. Dome pressure is taken as a measure of flow through this screen at every instant during speech. As in the flow system discussed previously, a bias flow is used to handle the problems of subject comfort, dead space, and moisture collection on the screen. The subject's articulatory apparatus is entirely free of the types of encumbrances offered by other flow-measuring devices routinely used. In addition, because the walls of the head chamber are rigid, unlike those of the face mask system previously discussed, articulatory motions cannot distort the shape of the chamber so that it itself will displace volume. During mo-

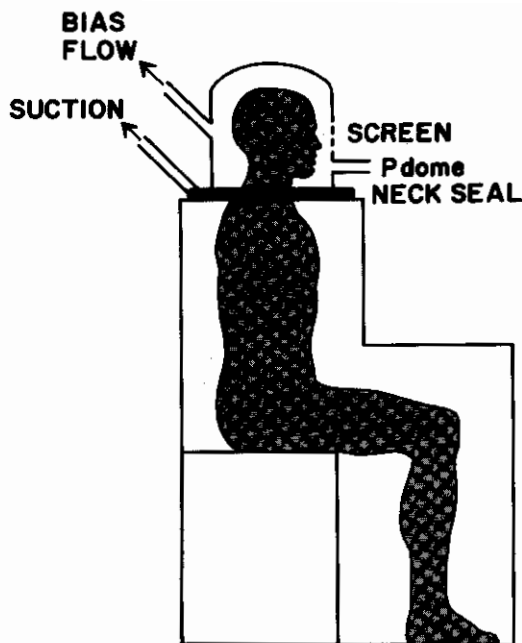

FIGURE 13. Chamber configuration for measuring transglottal flow ( $\dot{V}_{tg}$ ) during speech.

**BODY CHAMBER  
(DOOR OPEN)**

ments of articulation when the vocal tract is open to the dome, displacements of articulatory structures (for example, lips, cheeks, neck) are not registered as flow events, since the net volumes of the articulators themselves are not changing. During articulatory events where the vocal tract is closed to the dome (as during a voiced stop) an estimate of transglottal flow is still obtained, since flow through the larynx is reflected in displacements of the cheeks and neck which, in turn, cause volumes to be displaced inside the dome, these displacements being realized as flow through the dome screen. A small, but potential, source of error in such measurement is the compression or expansion of gas within the vocal tract. This can be taken into account through simultaneous measurements of oral pressure, although corrections for this factor represent very small adjustments. As discussed here, then, measurements of transglottal flow can be obtained during states where the vocal tract is either open or closed, the latter being a case where internal flow from the respiratory pump to the upper airway can be designated.<sup>6</sup> This

<sup>6</sup>Another approach we use to measure transglottal flow during speech utilizes the plethysmographic principles discussed under "Volume-Pressure Body Plethysmography." After correcting the volume signal from the chamber to make possible the measurement of rapid volume events, we differentiate the volume analogue to obtain a measure of flow at the chest wall. Such flow differs from transglottal flow only to the extent that part of the motion of the chest wall is related to gas compression (and decompression). This is

designation would be recognized by the experimental phonetician as an important bit of mechanical information during the stop phase of voiced plosives where voicing continues momentarily after closure of the vocal tract and flow continues transglottally. Such measurements are impossible with conventional flow-measuring devices (Isshiki and Ringel, 1964; Gilbert and Hixon, 1969), since closure at different valving points along the vocal tract precludes flow from the airway opening.

SIMULTANEOUS MEASUREMENTS OF ALVEOLAR  
PRESSURE AND TRANSGLOTTAL FLOW:  
VARIATIONS ON TWO THEMES

In preceding sections we have considered techniques for measuring transglottal flow and alveolar pressure. Each of these measurements gives information about the mechanical behavior of the speech apparatus. In combination, they become more than additive instructively, revealing much about the status of the laryngeal valve and how the respiratory pump acts upon and interacts with the larynx during speech. Figure 14 illustrates how these aerodynamic aspects of speech can be measured simultaneously by combining the essential features of the techniques previously discussed under "Plethysmographic Measurement of Alveolar Pressure" and "Upper Airway and Transglottal Flow Measurements" (Hixon and Warren, 1971). The subject is seated inside our chamber and is wearing a neck seal. The door of the chamber is closed, the lucite dome is over the subject's head and secured to the top of the chamber, and the air conditioner is turned on. A fine metal screen built into the body of the neck seal takes the place, in principle, of the screen within the wall of the dome, as previously described. Transglottal flow is measured as the pressure differential between the two sides of this screen (that is,  $P_{\text{dome}} - P_{\text{chamber}}$ ) with flow from the dome being directed back into the body chamber rather than being permitted to escape to the atmosphere. To insure accuracy of measurement of rapid events of interest, the mechanical time constants of the dome and body chambers are empirically adjusted to be equal. The feature of not permitting air to escape from the total system dictates that the only volume change seen by the plethysmograph is that related to compression (and decompression) of gas within the subject. This means that measurements of alveolar pressure can be made along the lines discussed in the section on "Plethysmographic Measurement of Alveolar Pressure." Having both transglottal flow and alveolar pressure in analogue forms, we are able not only to continuously record them but also to make use of on-line electronic computations to provide real-time readouts of aerodynamic power and impedance, respec-

---

a small component compared to the volume displacement component, so that flow of the chest wall reflects transglottal flow to a good approximation. The advantage of this approach over the dome approach discussed in text is that the head is unencumbered and accurate acoustic recordings can be made, if desired. We have chosen to emphasize the dome technique because it can be easily combined with our technique for measuring alveolar pressure.

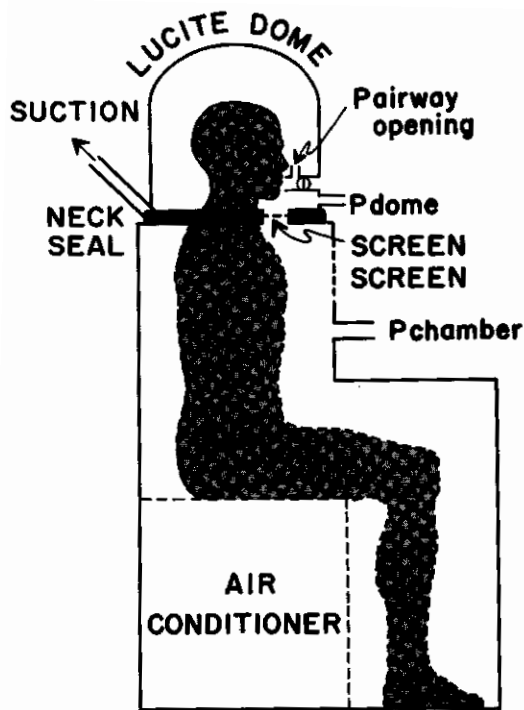

FIGURE 14. Chamber configuration for making simultaneous measurements of alveolar pressure ( $P_{alv}$ ) and transglottal flow ( $\dot{V}_{tg}$ ) during speech.

### $P_{alv}$ and $\dot{V}_{tg}$ CONFIGURATION

tively. Of final concern with reference to the configuration shown in Figure 14 is the fact that estimates of changes in lung volume can also be obtained along with measurements of transglottal flow and alveolar pressure. These estimates reside in the first time integral of our transglottal flow analogue, which as we have seen is provided via continuous measurement of the pressure differential across the screen of our neck seal (Chistovich and Kozhevnikov, 1969; Hixon and Warren, 1971).

### ULTRASONIC SCANS OF THE TONGUE

In speech, the mechanical significance of the upper airway depends in part on the changing geometry of the airway boundaries. An obvious major determiner of this geometry is the dorsal surface of the tongue, a boundary that can assume a variety of configurations and that runs nearly the entire length coordinate of the vocal tract. A new methodological development which enables us to visualize the tongue's dorsal surface when the tongue is stationary, is ultrasonic scanning. This technique, developed under the direction of my colleague Fred Minifie (Minifie et al., 1971), provides data



in the form of echograms of the dorsal surface of the tongue in different planes. As examples of the types of visualizations that are possible, longitudinal and transverse echograms will be considered here. In x-ray parlance, these represent the equivalent of lateral and coronal-oblique views, respectively. In the present method, pulsed ultrasound (Kelsey, Minifie, and Hixon, 1968) is generated by a 2.25 MHz transducer and transmitted through the tongue mass to the tissue-air interface along the dorsal surface of the tongue. The impedance change at this interface causes much of the transmitted energy to be reflected back to the generating site where it is sensed by the same transducer acting as a receiver. The echoes received are processed as a series of dots in a B-scan mode (Kelsey et al., 1968), the resulting composite of echoes providing a two-dimensional view of the tongue that is displayed on the screen of an ultrasonoscope.

The left side of Figure 15 shows the transducer movement pathway fol-

### LONGITUDINAL ECHOGRAMS

### TRANSVERSE ECHOGRAMS

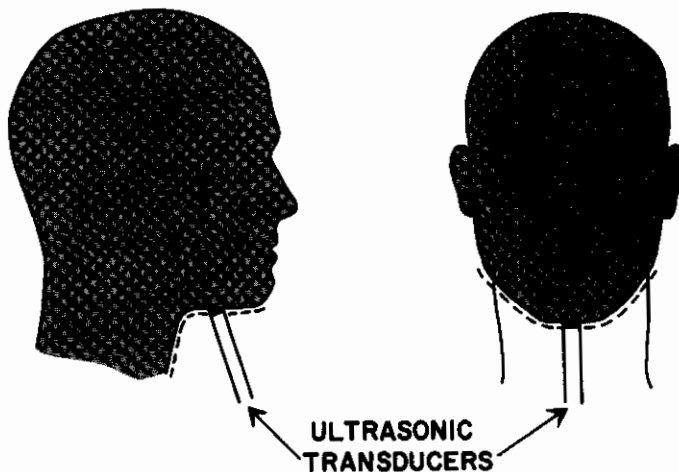

FIGURE 15. Transducer movement pathways for obtaining ultrasonic echograms of the dorsal surface of the tongue. Left: Longitudinal scan in the midsagittal plane. Right: Transverse scan in a coronal-oblique plane.

lowed to obtain longitudinal echograms of the dorsal surface of the tongue in the midsagittal plane. Such scans are obtained by moving the ultrasonic probe in compound sector motions from a midline position on the anterior neck wall at the level of the larynx upward to the mandibular symphysis. For a complete scan this procedure takes approximately three seconds, during which the subject must maintain a constant tongue position. A sample echogram obtained with the procedure described is shown in Figure 16. There the tongue is shown in a resting configuration, with the facial contour also being shown to aid in appreciating the relative position of the tongue within the head. The facial outline was obtained by passing the transducer probe over the subject's face with the ultrasonoscope set at minimum gain. This procedure

shows only the changing position of the ultrasonic probe itself. The diverging straight lines in Figure 16 are scan lines made by brightening the ultrasonoscope at various points to provide identification of locations for transverse scans that were made in the experiment from which this echogram is taken. Longitudinal echograms of the type shown in Figure 16 can be obtained during various speech utterances, the only provision being that the utterances must be of a sustainable nature to enable time for the scan to be completed.

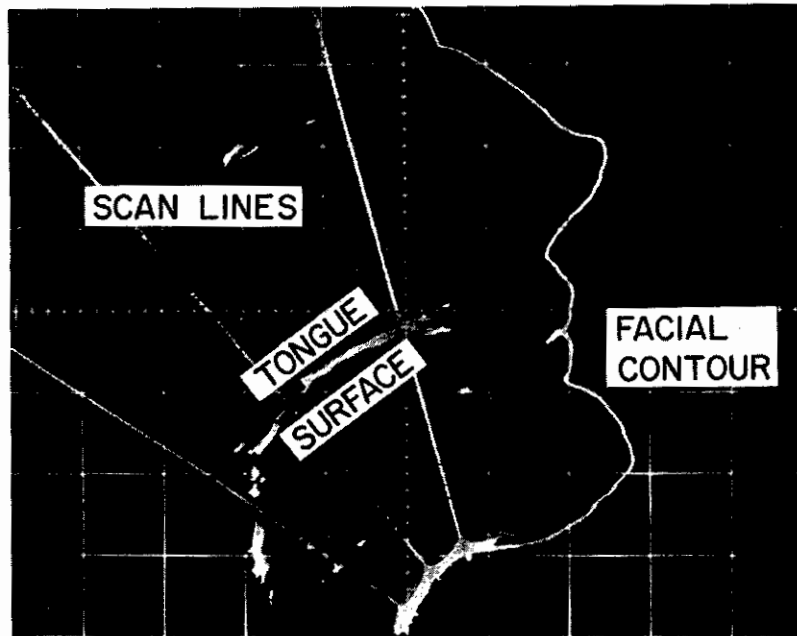

FIGURE 16. Longitudinal echogram of the dorsal surface of the tongue at rest. The facial contour is shown, as are three scan lines along which transverse scans are usually made. Reprinted by permission, from Minifie et al. (1971). Provided by courtesy of F. D. Minifie.

The right side of Figure 15 depicts the transducer movement pathway for obtaining transverse echograms of the tongue as well as coronal facial contours. There the scanning direction has been rotated  $90^\circ$  relative to the scanning direction for longitudinal echograms of the tongue. Again, scans are obtained by moving the transducer probe in compound sector motions in a given plane. Some sample transverse echograms are shown in Figure 17. Each of these was obtained by scanning in the coronal-oblique plane through the inferior surface of the chin and the tongue blade. The upper left echogram shows a slightly convex curvature of the tongue blade during a sustained /u/ production. The upper right echogram shows the markedly convex tongue blade configuration when the tongue is at rest, while the lower echogram depicts

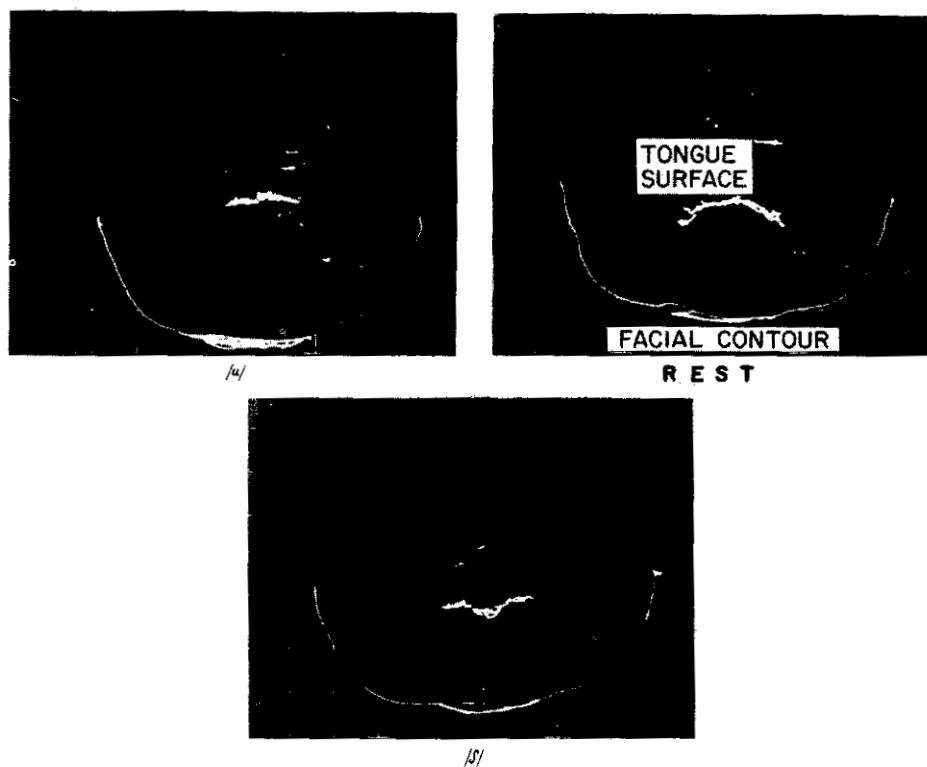

FIGURE 17. Transverse (coronal-oblique) echograms of the dorsal surface of the tongue, under three conditions. The jaw contour is shown. Upper left: Sustained /u/ production. Upper right: The tongue at rest. Below: Sustained /j/ production. Reprinted, by permission, from Minifie et al. (1971). Provided by courtesy of F. D. Minifie.

the concave surface of the tongue blade observed during a production of /j/. Facial contours in the three echograms show the inferior and lateral outline of the jaw.

Taken together the two scan views discussed here provide an effective means for mapping tongue contours during sustained utterances. Unfortunately, dynamic articulatory movements cannot be monitored with the techniques described, although such monitoring may be possible in the future. As pointed out by Minifie et al. (1971), commercial ultrasonic scanners are now available that make it possible to visualize linear scans at rates of 16 per second. Minifie et al. suggest that, if such scanners can be modified to provide rapid compound sector scans, it may be possible to monitor dynamic articulatory movements of the tongue during utterance. Such an advancement would be welcomed by speech physiologists concerned with comprehensive studies of tongue dynamics without the hazards of x-ray procedures.

## LASER HOLOGRAPHIC INTERFEROGRAMS: THE STUDY OF SPEECH MOVEMENTS

Some parts of the speech apparatus are arranged such that portions of their boundaries are visible on the exterior surface of the torso, head, or neck regions (such as the abdominal wall and the cheeks). Other parts lie deep to these visible surfaces but nevertheless have part of their boundaries revealed through external geometric landmarks that are more or less obvious in different speakers (for example, the costal margin and the thyroid prominence). Since the activities of both of these types of parts are to some extent reflected by the surface motions they create, it is instructive to be able to visualize the patterns of motion distributed over the exterior of the speech apparatus. A technique which shows rather provocative potential for being able to provide such a visualization is laser holographic interferometry. Although we have not yet used interferometry in our own laboratory and are only beginning to instrument along such lines, its successful use by Zivi and Humberstone (1970) in the study of respiratory physiology leads us to believe that interferograms will be a useful new tool for speech research.

Figure 18 illustrates schematically the experimental arrangement used to

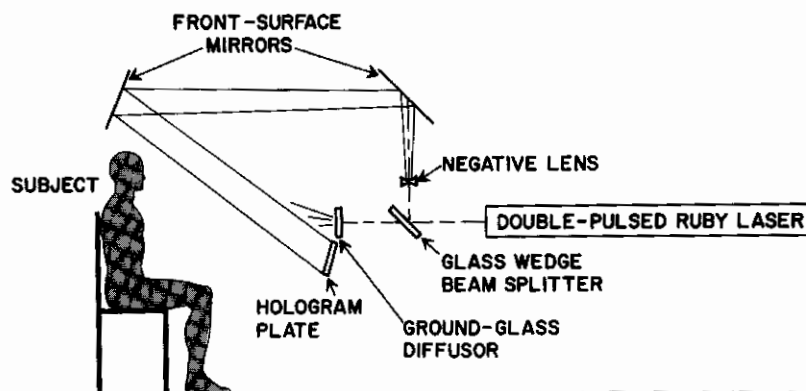

FIGURE 18. Experimental arrangement for obtaining laser holographic interferograms of the surface of a speaker. Modified from Zivi and Humberstone (1970).

obtain interferograms of the surface of a subject (Zivi and Humberstone, 1970). There, double-pulsed ruby laser holography is used to produce an image of the patterns of motion of a target, which in this instance is the anterior torso, neck, and head regions of a human. The data provided are in the form of a complex diffraction gradient on photographic film, a gradient caused by the interference of two coherent light beams from the same laser source. The target structures are located in one of the beams while a reference beam provides wavelength and phase information about the laser output. The reference beam and the light reflected by the target are combined at the photographic film with the interference between the two beams providing

the needed diffraction gradient. Subsequent illumination of the diffraction gradient by a laser simulating the reference beam results in diffracted rays that duplicate those that originally came from the target structure, the result being that a three-dimensional image of the target appears in the position previously occupied by the target. In the use of double-pulsed interferometry (Zivi and Humberstone, 1970) a double-exposure hologram is made of the target. Target movement between the two exposures results in a photographic image that shows the target in the two positions at the instants of the double pulsing of the laser. When the two images reconstructed by the hologram are superimposed, they show interference fringes on the imaged target, fringes that provide quantitative information on the movement of the target between the two exposures. Therefore, without touching the subject, it is possible to both visualize and measure the motions of body surfaces during physiological processes. This capability is illustrated in Figure 19, which shows a photograph of a reconstructed holographic image of a subject performing a maximally forced vital capacity maneuver into a mouthpiece. This somewhat psychedelic image was made by causing a ruby laser to double-pulse with an interval between pulses of 150 microseconds. Since the target moved only slightly between pulses, the subject himself does not appear to have moved; however, the interference fringes in the picture indicate the nature of the movement pattern which actually occurred between laser exposures. Dark fringes in the image show points on the subject that moved between exposures by an amount such that the light reflected from the second laser pulse was shifted one-half wavelength with respect to the corresponding ray from the first pulse (Zivi and Humberstone, 1970). Although quantitative interpretation of Figure 19 is possible, it will suffice here to interpret the interferogram qualitatively. Except for areas where motion of the target is not approximately toward the hologram, all points on a given dark fringe are traveling at the same velocity. Closed loops made by dark fringes indicate that the surface outlined by the loop is becoming more or less curved. The large number of fringes show that considerable movement occurred on the chest-abdomen surface during the vital capacity maneuver. From knowing the direction of body surface displacement, one can infer that the series of closed loops in this area shows the surface to be flattening during the expiration. The maximum displacement appears to be at the torso midline. Much less motion during the maneuver seems to have occurred in the lateral pectoral regions of the chest, because few fringes are noted there. The cheek area shows several closed loop fringes which seem to fit the reasonable interpretation that the cheek is moving outward like a drum membrane because of the large transmural pressure during the forced expiration. Areas of the neck also appear to move somewhat like a drum membrane, as can be noted below the mandible and above the suprasternal notch area.

We can only conjecture concerning the potential applications of interferograms in speech research. Any application where one is interested in the

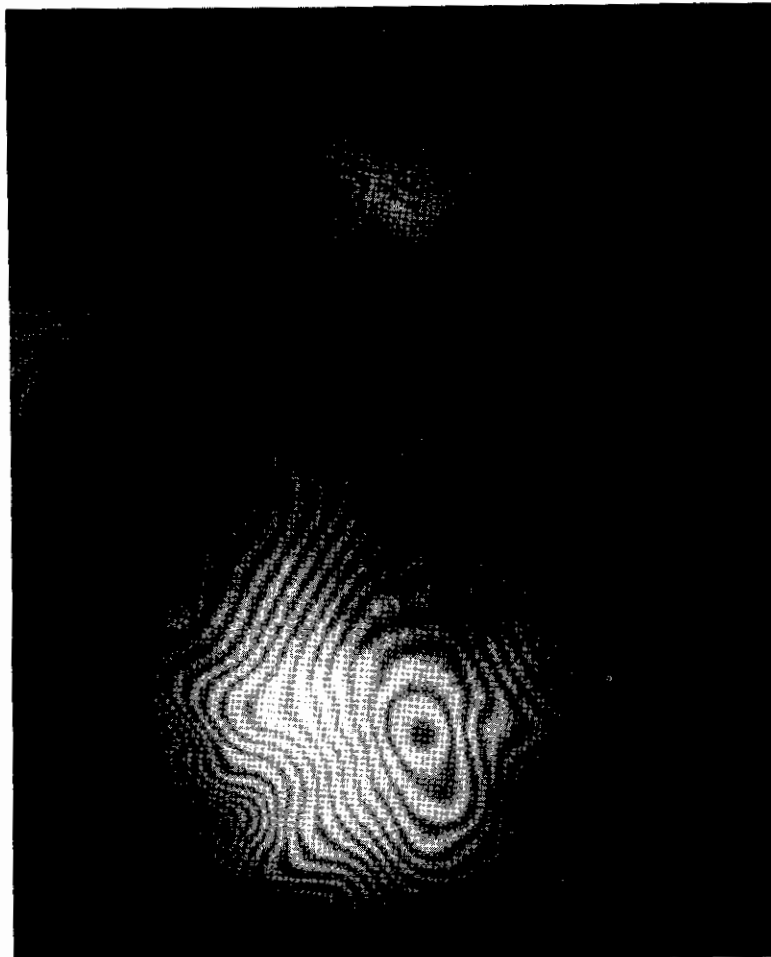

FIGURE 19. Photograph of a reconstructed holographic image of a subject during the performance of a maximally forced vital capacity maneuver. Provided by courtesy of S. M. Zivi, Laser Products Manager, Physical Research Center, TRW Instruments, El Segundo, California 90245.

nature of motion patterns is an obvious potential use of the holographic technique. The technique may be useful, for example, in estimating the volumes displaced by various parts of the speech apparatus. When combined with pressure measurements, such estimates may permit estimates of regional resistances and compliances. It has already been demonstrated that the technique can be used to study the influence of vocally induced vibrations as their effect is realized in surface motions of a speaker (Zivi and Humberstone, 1970). Since interferograms provide information about some structures near the external surface of the body, they seem a likely candidate for a method of tracking changes in laryngeal height during speech. Finally, Zivi and Humber-

stone (1970) have suggested that quantitative measurements could be made of the mechanical response of selected muscles as they are electrically stimulated. Such information would be of obvious value to those of us who are interested in the speech of patients with neurologically based disorders.

#### ET CETERA

This paper has been an attempt to bring to the awareness of those working in speech pathology and dentistry some new "ways of knowing" about the bio-mechanical behavior of the speech apparatus. I have considered some rather specific applications of these ways of knowing. I hope that I have at the same time provided a broad enough general treatment of the topics discussed herein that with a minimum of creativity they can be extended to the research and clinical problems of others. After reviewing what I said in the previous sections of this paper, I was struck by two things. The first is how much more we would probably understand about speech mechanisms if, in talking to ourselves about them, we considered the speech apparatus in total rather than as a collection of parts functioning somewhat independently of one another. The second is how many different "disciplines" have made contributions to the ideas outlined in this paper (for example, physiology, speech pathology, dentistry, biology, engineering, electronics, acoustics, physics). This second point particularly strikes me because I wonder how much further advanced we would be on topics such as "Oral-Facial Function: Clinical Research in Dentistry and Speech Pathology" were each of us a little less provincial in our approach to problems. This, of course, is what conferences such as this one are all about—broadening our perspective—, and that is why we met in Ann Arbor.

#### ACKNOWLEDGMENT

The preparation of this paper was supported by Research Grant No. NS 09656 and Research Career Development Award No. 1 K4 NS 41350 from the National Institute of Neurological Diseases and Stroke.

#### REFERENCES

- ABBES, J., The influence of the gamma motor system on jaw movement during speech. Doctoral dissertation, Univ. of Wisconsin (1971).
- ABBES, J., and NETSELL, R., The inferential role of the gamma loop in speech production: A new application of an old technique. Paper presented at the Annual Convention of the American Speech and Hearing Association, New York, New York (1970).
- ABBES, J., and NETSELL, R., An interpretation of continuous articulator acceleration as a muscle forcing function. Paper presented at the spring meeting of the Acoustical Society of America, Washington, D.C. (1971).
- AGOSTONI, E., and MEAD, J., Statics of the respiratory system. In W. Fenn and H. Rahn (Eds.), *Handbook of Physiology, Section 3, Respiration 1*. Washington, D.C.: Amer. Physiol. Soc., 387-409 (1964).
- AGOSTONI, E., and RAHN, H., Abdominal and thoracic pressures at different lung volumes. *J. appl. Physiol.*, 15, 1087-1092 (1960).
- ARUTJUNJAN, E., GRANSTREM, M., and KOZHEVNIKOV, V., Some characteristics of the

- respiratory system acting in speech. Paper presented to the Seventh International Conference on Medical and Biological Engineering, Stockholm (1967).
- BOUHUYS, A., PROCTOR, D., and MEAD, J., Kinetic aspects of singing. *J. appl. Physiol.*, **21**, 483-496 (1966).
- CHRISTOVICH, L., and KOZHEVNIKOV, V., Some aspects of the physiological study of speech. In L. D. Proctor (Ed.), *Biocybernetics of the Central Nervous System*. Boston: Little, Brown, 305-321 (1969).
- CHRISTIANSEN, R., and MOLLER, K., Instrumentation for recording velar movement. *Amer. J. Orthodont.*, **59**, 448-455 (1971).
- COLLINS, W. E., INC., *Clinical Spirometry: Instructions for Use of the Collins Respirometer and for Calculation and Interpretation of Data in Pulmonary Function and Basal Metabolism Testing*. Boston: Warren E. Collins, Inc. (1957).
- DRAPER, M., LADEFEGED, P., and WHITTERIDGE, D., Respiratory muscles in speech. *J. Speech Hearing Res.*, **2**, 16-27 (1959).
- DUBOIS, A., BOTELHO, S., and COMROE, J., JR., A new method for measuring airway resistance in man using a body plethysmograph: Values in normal subjects and in patients with respiratory disease. *J. clin. Invest.*, **35**, 327-335 (1956).
- DUBOIS, A., BRODY, A., LOUIS, D., and BURCESS, B., JR., Oscillation mechanics of lungs and chest in man. *J. appl. Physiol.*, **8**, 587-594 (1956).
- DUOMARCO, J., and RIMINI, R., *La Presion Intra-Abdominal en el Hombre*. Buenos Aires: El Aterneo (1947).
- FINUCANE, K., DAWSON, S., PHELAN, P., GREEN, I., WOHL, M., and MEAD, J., Frequency dependence of lower airway resistance in man. Paper presented at the 54th annual meeting of the Federation of American Societies for Experimental Biology, Atlantic City (1970).
- FRENCH, J., A variable inductance linear displacement transducer. *J. med. biol. Engng.*, **4**, 495-497 (1966).
- FRENCH, J., and SIEBENS, A., Real-time elimination of the electrocardiogram from the integrated electromyogram of the diaphragm. Paper presented at the Eighth International Conference on Medical and Biological Engineering, Chicago (1969).
- GILBERT, H., and HIXON, T., Oral airflow during stop consonant production. Paper presented at the Annual Convention of the American Speech and Hearing Association, Chicago (1969).
- GOLDMAN, M., KNUDSON, R., MEAD, J., PETERSON, N., SCHWABER, J., and WOHL, M., A simplified measurement of respiratory resistance by forced oscillation. *J. appl. Physiol.*, **28**, 113-116 (1970).
- GRIMBY, G., TAKISHIMA, T., GRAHAM, W., MACKLEM, P., and MEAD, J., Frequency dependence of flow resistance in patients with obstructive lung disease. *J. clin. Invest.*, **47**, 1455-1465 (1968).
- HARDY, J. C., Air flow and air pressure studies. *Proceedings of the Conference Communicative Problems in Cleft Palate. ASHA Reports Number 1*, 141-152 (April 1965).
- HARDY, J., and EDMONDS, T., Electronic integrator for measurement of partitions of the lung volume. *J. Speech Hearing Res.*, **11**, 777-786 (1968).
- HIXON, T., Turbulent noise sources for speech. *Folia phoniatr.*, **18**, 168-182 (1966).
- HIXON, T., Respiratory mechanics during speech production. Paper presented at the Annual Convention of the American Association for the Advancement of Science, Chicago (1970).
- HIXON, T., An electromagnetic method for transducing jaw movements during speech. *J. acoust. Soc. Amer.*, **49**, 603-606 (1971a).
- HIXON, T., Mechanical aspects of speech production, 1: The respiratory pump. Paper presented at the Annual Convention of the American Speech and Hearing Association, Chicago (1971b).
- HIXON, T., Respiratory function in speech. In F. Minifie, T. Hixon, and F. Williams (Eds.), *Normal Aspects of Speech, Hearing and Language*. Englewood Cliffs, New Jersey: Prentice-Hall (in press).
- HIXON, T., KLATT, D., and MEAD, J., Influence of forced transglottal pressure changes on vocal fundamental frequency. Paper presented at the fall meeting of the Acoustical Society of America, Houston (1970).
- HIXON, T., MEAD, J., and GOLDMAN, M., Separate volume changes of the rib cage and



- abdomen during speech. Paper presented at the Annual Convention of the American Speech and Hearing Association, New York, New York (1970).
- HIXON, T., MINIFIE, F., PEYROT, A., and SIEBENS, A., Mechanical behavior of the diaphragm during speech production. Paper presented at the fall meeting of the Acoustical Society of America, Cleveland (1968).
- HIXON, T., SIEBENS, A., and EWANOWSKI, S., Respiratory mechanics during speech production. Paper presented at the spring meeting of the Acoustical Society of America, Ottawa (1968).
- HIXON, T., SIEBENS, A., and MINIFIE, F., An EMG electrode for the diaphragm. *J. acoust. Soc. Amer.*, **46**, 1588-1590 (1969).
- HIXON, T., and WARREN, D., Use of plethysmographic techniques in speech research: Two laboratories' experiences. Paper presented at the Annual Convention of the American Speech and Hearing Association, Chicago (1971).
- ISSHIKI, N., and RINGEL, R., Air flow during the production of selected consonants. *J. Speech Hearing Res.*, **7**, 233-244 (1964).
- KELSEY, C., MINIFIE, F., and HIXON, T., Applications of ultrasound in speech research. *J. Speech Hearing Res.*, **12**, 564-575 (1968).
- KIM, B., A physiological study of the production mechanisms of Korean stop consonants. Doctoral dissertation, Univ. of Wisconsin (1971).
- KLATT, D., STEVENS, K., and MEAD, J., Studies of articulatory activity and airflow during speech. In A. BOUHUYS (Ed.), *Sound Production in Man. Ann. N.Y. Acad. Sci.*, **155**, 42-55 (1968).
- KONNO, K., and MEAD, J., Measurement of the separate volume changes of rib cage and abdomen during breathing. *J. appl. Physiol.*, **22**, 407-422 (1967).
- KUNZE, L., Evaluation of methods of estimating sub-glottal air pressure. *J. Speech Hearing Res.*, **7**, 151-164 (1964).
- LIEBERMAN, P., KNUDSON, R., and MEAD, J., Determination of the rate of change of fundamental frequency with respect to subglottal air pressure during sustained phonation. *J. acoust. Soc. Amer.*, **45**, 1537-1543 (1969).
- LUBKER, J. F., Aerodynamic and ultrasonic assessment techniques in speech-dentofacial research. *Proceedings of the Workshop Speech and the Dentofacial Complex: The State of the Art. ASHA Reports Number 5*, 207-223 (October 1970).
- LUBKER, J., and MOLL, K., Simultaneous oral-nasal air flow measurements and cinefluorographic observations during speech production. *Cleft Pal. J.*, **2**, 257-272 (1965).
- MEAD, J., Volume displacement body plethysmograph for respiratory measurements in human subjects. *J. appl. Physiol.*, **15**, 736-740 (1960).
- MEAD, J., A summary of one laboratory's experience with body plethysmography. In H. Herzog (Ed.), *Respiration*. Basel: S. Karger (1968).
- MEAD, J., and MILIC-EMILI, J., Theory and methodology in respiratory mechanics with glossary of symbols. In W. Fenn and H. Rahn (Eds.), *Handbook of Physiology, Section 3, Respiration I*. Washington, D.C.: Amer. Physiol. Soc., 363-376 (1964).
- MEAD, J., PETERSON, N., GRIMBY, G., and MEAD, J., Pulmonary ventilation measured from body surface movements. *Science*, **156**, 1383-1384 (1967).
- MEAD, W., and COLLINS, V., The principles of dilatancy applied to techniques of radiotherapy. *Amer. J. Roentgenol. rad. Ther. nucl. Med.*, **71**, 864-866 (1954).
- MILIC-EMILI, J., MEAD, J., TURNER, J., and GLAUSER, E., Improved technique for estimating pleural pressure from esophageal balloons. *J. appl. Physiol.*, **19**, 207-211 (1964).
- MINIFIE, F., KELSEY, C., ZAGZEBSKI, J., and KING, T., Ultrasonic scans of the dorsal surface of the tongue. *J. acoust. Soc. Amer.*, **49**, 1857-1860 (1971).
- MOLLER, K., and CHRISTIANSEN, R., Instrumentation for recording velar movement. Paper presented at the Annual Convention of the American Speech and Hearing Association, Chicago (1969).
- MOLLER, K., MARTIN, R., and CHRISTIANSEN, R., A technique for recording velar movement. *Cleft Pal. J.*, **8**, 263-276 (1971).
- OHALA, J., HIKI, S., HUBLER, S., and HARSHMAN, R., Photoelectric methods of transducing lip and jaw movements in speech. *Univ. Calif. (L.A.) Work. Papers Phonet.*, **10**, 135-144 (1968).
- PERKINS, W., and KOIKE, Y., Patterns of subglottal pressure variation during phonation. *Folia phoniatr.*, **21**, 1-8 (1969).
- PESLIN, R., HIXON, T., and MEAD, J., Variation des resistances thoracopulmonaires au cours

- du cycle ventilatoire etudiees par methode d'oscillation (Variations of thoraco-pulmonary resistance during the respiratory cycle, studied by forced oscillations). *Bull. Physio-Pathol. Res.*, **7**, 173-186 (1971).
- PEYROT, A., HERTEL, G., and SIEBENS, A., Pulmonary ventilation measured by a single linear displacement transducer. *J. med. biol. Engng.*, **7**, 1-2 (1969).
- SUBTELNY, J., WORTH, J., and SAKUDA, M., Intraoral pressure and rate of flow during speech. *J. Speech Hearing Res.*, **9**, 498-518 (1966).
- SUSSMAN, H., and SMITH, K., Transducer for measuring mandibular movements. *J. acoust. Soc. Amer.*, **48**, 857-858 (1970).
- VAN DEN BERG, J., Direct and indirect determination of the mean subglottic pressure. *Folia phoniatr.*, **8**, 1-24 (1956).
- ZIVI, S., and HUMBERSTONE, G., Chest motion visualized by holographic interferometry. *Med. Res. Engng.*, **9**, 5-7 (1970).

# JAW MOTION DURING SPEECH

CHARLES H. GIBBS *and* THEODORE MESSERMAN

*Case Western Reserve University, Cleveland, Ohio*

A collaborative research project undertaken by engineers, dentists, and computer scientists has been in progress at Case Western Reserve University since 1963. Although this project was originated to study jaw motions for contribution to advances in dentistry, the instrumentation and data analysis techniques that developed are applicable to the study of jaw motion during speech.

Because they were designed to be broad in scope, the instrumentation and data-processing system enabled us to explore many methods of data organization and pattern recognition techniques. The instrumentation measures the motion of the entire jaw as a function of time. Data outputs can be plotted or calculated for any combination of motion, velocity, acceleration, and time for any or all jaw points. During this preliminary investigation of jaw motion during speech, orbits of motion in three planes of the central incisor and condyles, vertical motion versus time of the central incisor and condyles, vertical velocity versus time, and vertical velocity versus vertical position of the central incisor were plotted.

The data on jaw motion during speech is presented in comparison with jaw motions during chewing, to show preliminary comparisons, rather than oriented to answer a particular research problem. These comparisons not only illustrate the use of the instrumentation and the data-processing system but also indicate areas for future study.

## METHOD

Gibbs, Reswick, and Messerman (1966) designed the Case Gnathic Replicator because existing systems did not record accurately motion of the entire jaw in a form that could be entered efficiently on a digital computer. The CGR tape-records jaw motion data in all six degrees of freedom so that the motions of all jaw points (condyles, coronoid processes, teeth, and so on) are known. The stored information can be analyzed by computer or played back to operate a cast which will duplicate the exact motion of the patient's jaw, as shown in Figure 1.

The measuring instrumentation, designed by Cannon, Reswick, and Messer-

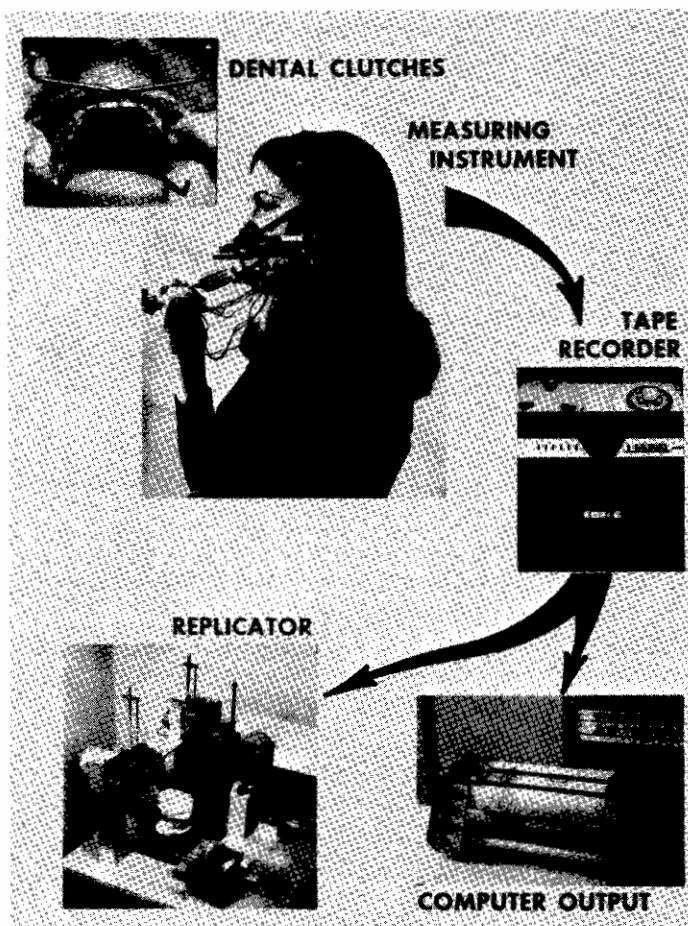

FIGURE 1. The Case Gnathic Replicator, for measuring jaw motion.

man (1964), consists of two face bows attached to the teeth by cast-formed clutches. The clutches are cemented to the labial surfaces of the teeth and do not interfere with articulation and occlusion. The clutches pass between the lips and allow the lips to seal at closure for swallowing. Six digital transducers mounted between the face bows measure the motion of the jaw with respect to the skull. There is no fixation or restraint on the postural movements of the head. The instrument is lightweight, compact, and free-working, and the connection to the subject's teeth is as minimal as possible to facilitate the accurate measurement of natural reflex movements during chewing and speech. The maximum measurement error is less than 0.005 inches ( $\frac{1}{40}$  mm) and the instrument weighs approximately 100 grams.

During a test of jaw motion, the subject may sit in an ordinary chair and the signals are recorded on magnetic tape in digital form. Digital transducers

and digital tape-recording were chosen over more common analogue systems to maintain high precision and to eliminate analogue-to-digital conversion on entry to a large digital computer. Digital-stepping motor drives were used in the replicator device because they can be controlled without feedback by the digitally recorded signals on tape. The replicator is controlled by the tape, played back at  $\frac{1}{10}$  speed. The slow motion playback may be of special value for visual study by students and researchers.

One advantage of this system over intraoral telemetry developed by Glickman, Pameijer, and Roeber (1968) and presently used at Tufts University is that the motion throughout the entire cycle is known rather than just the motion of a single point in a single line of movement near closure. Another advantage of this system is that the motion of all jaw points is known, so the motion of the condyles, for example, can be compared simultaneously with the motions of the teeth. A third advantage of this system is precision. The telemetry group has been using switch spacings of  $\frac{1}{2}$  mm. The basic step size of our system is  $\frac{1}{16}$  mm, which results in a maximum possible error of  $\frac{1}{8}$  mm; hence, our system is at least four times as precise.

Other research groups have extensively used motion photography of face bow points and cineradiography of the jaw itself. Although these methods have minimal attachment to the jaw, they usually require head fixation which may alter the natural reflex movements during speech and chewing. Their most serious disadvantage, however, is the difficulty in reducing the data frame by frame on an optical viewer. For example, if six measurements are taken for 32 frames each second, 11,520 measurements result for each minute of jaw motion. Therefore, it is prohibitive to make large comparative studies with these techniques. In comparison, our system computes this motion of any three jaw points 100 times per second and stores them on magnetic tape for computer plotting at about the rate of one minute of computer time per minute of recorded data.

If one can judge by patient reaction, our instruments do not interfere significantly with natural speech or chewing movements.

During the course of recording the jaw motion of 28 subjects, we have figured our cost to be about \$300 per subject. This includes clutch construction before the test, magnetic tapes for recording the data, and other supplies. The cost of computer time to calculate numerous parameters and statistical measures of these parameters, and computer time to plot the orbits of motion of three jaw points on five different chart papers is about \$60 per minute of jaw motion.

### *Data Processing*

To identify patterns of jaw motion, a wide variety of computer outputs were needed. The common approach, a number of unrelated computer-plotting programs, would entail many separate programs for the necessary combinations of scale sizes, projections of position, time and velocity, different jaw points, normalization, and so on.

A new processor language analyzer created by Szymanski (1968), which coordinates a collection of printer and plotter output routines, met these needs. The analyzer, though large and complex, is controlled by simple language which can be increased as project requirements increase. The analyzer language consists of functions for defining the type of plot; options for defining the axes to be plotted, scale size, normalization (if any), directional arrows, and parameters for defining the data to be plotted. Although the effort in developing it was considerable, the analyzer has been invaluable in utilizing the potential of the instrumentation.

## RESULTS

Figures 2 through 10 compare the speech and chewing motions of two subjects. These are data from two individuals and not averages or compilations of many cases. These speech data must be interpreted in this light.

The frontal view in Figure 2 shows jaw motions during speech and chewing of two subjects with ideal occlusion. The maximum vertical opening was typically two to four times more for chewing than for speech. Less than a 0.1-inch range of lateral movement appears in the speech movements in comparison to as much as 0.7 inch for chewing. Directional arrows on the closing orbits show

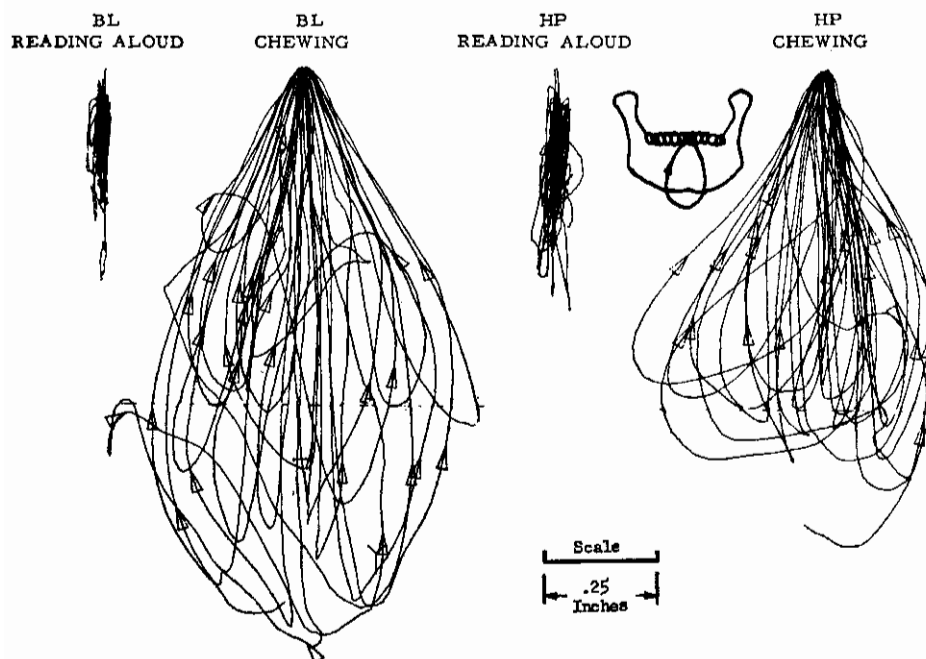

FIGURE 2. Orbits of motion of the central incisor in the frontal plane for speech and chewing.

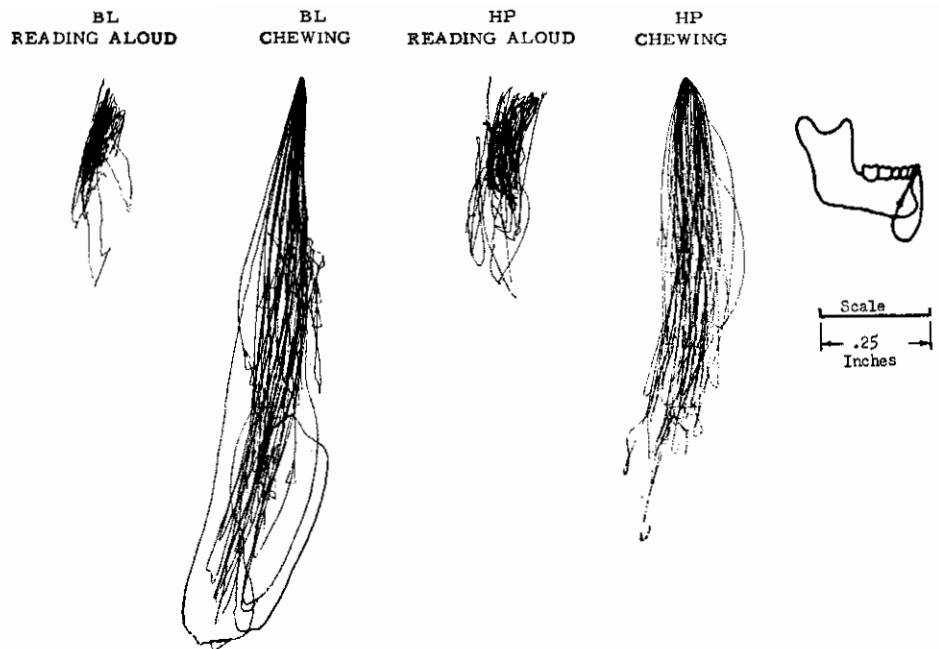

FIGURE 3. Orbits of motion of the central incisor in the sagittal plane for speech and chewing.

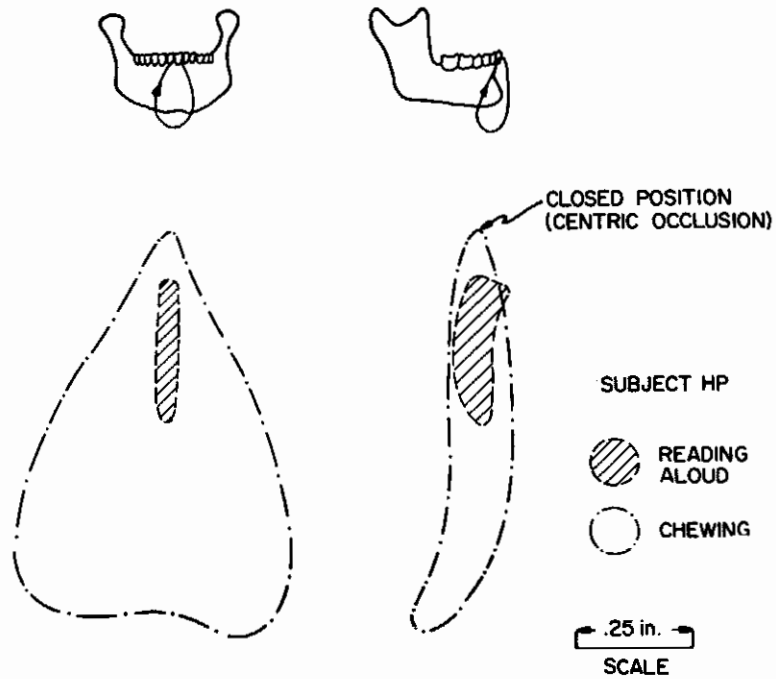

FIGURE 4. Typical areas of jaw motion during speech and chewing for Subject HP with ideal occlusion.

that during chewing the jaw opens medially and then moves laterally early in the closing stroke. A wide range of angles of approach on closing occurs during chewing.

Orbits of motions corresponding to those of Figure 2 but in the sagittal view are shown in Figure 3. The ratio of horizontal to vertical movements is greater for speech (about 1:3) than for chewing (about 1:7). Directional arrows on the closing orbits show that during chewing the jaw closes rearward of opening. The jaw seldom returns to the closed position during speech as it does during chewing.

Typical areas of jaw motion of one subject during speech and chewing are compared schematically in Figure 4. Figure 5 shows the vertical motion of the central incisor and condyles, versus time, for a subject with ideal occlusion chewing soft food. During the closing stroke, the left condyle reached its maximum height first (first vertical line in Figure 5); therefore, the left side is termed the working side and, from our past studies, the food is most likely on the left side. The right condyle and central incisor reached maximum height about the same time (second vertical line, Figure 5). The central incisor curve

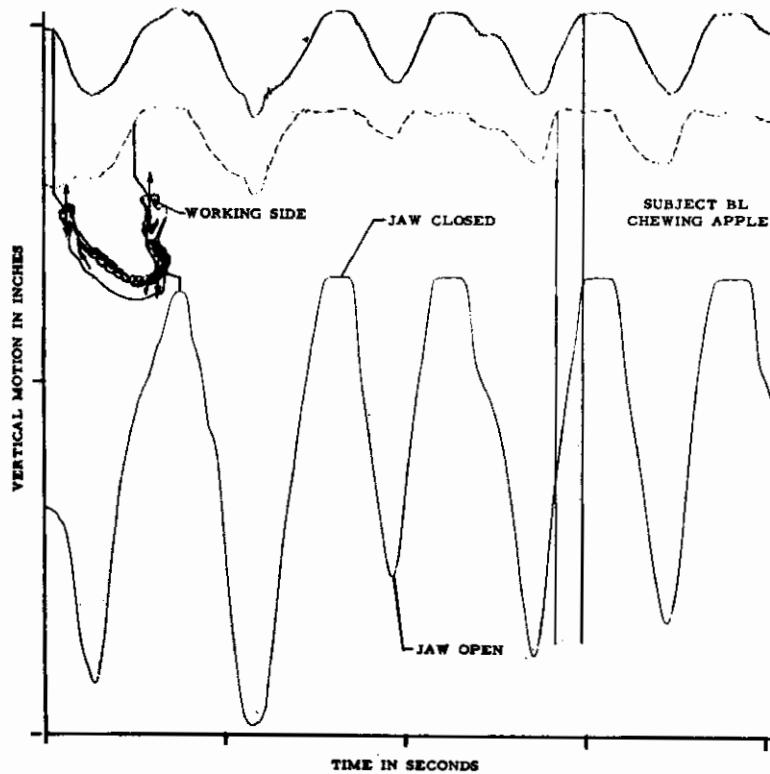

FIGURE 5. Vertical motion of the central incisor and condyles vs time for a subject with ideal occlusion during chewing.



shows a series of flat tops, indicating that the jaw stopped for about 0.2 seconds at closure.

Viewing extended position versus time plots similar to Figure 5 for 16 subjects with ideal occlusion chewing soft and hard food demonstrated three facts: (1) The first few chews do not produce full closure at the central incisor (food large and anterior), and when full closure is not attained, there is no stoppage of the jaw. (2) After the first few chews, full closure is reached at the central incisors; usually a decided period follows in which the jaw remains closed and motionless. (3) In the first chews of a series, one condyle (the working one) reached terminal position first. This pattern changed toward the end of the chewing series when the condyles moved more symmetrically.

Comparing the speech motions shown in Figure 6 with the chewing motions in Figure 5 indicates how little vertical condylar motion occurs during speech (about 0.05 inch for Subject BL and 0.1 inch for Subject HP). No stoppage of the jaw is indicated during speech. The average maximum velocities for Subject HP were: speech, 1.7 in./sec; chewing, 5.9 in./sec. For Subject BL: speech, 1.6 in./sec; chewing, 6.2 in./sec.

Figures 7, 8, 9, and 10 show the vertical motion versus time of the central incisor of six subjects pronouncing *wan*, *tus*, *reef*, and *nor*. These four special words were chosen for this study because of a previous sound analysis of them

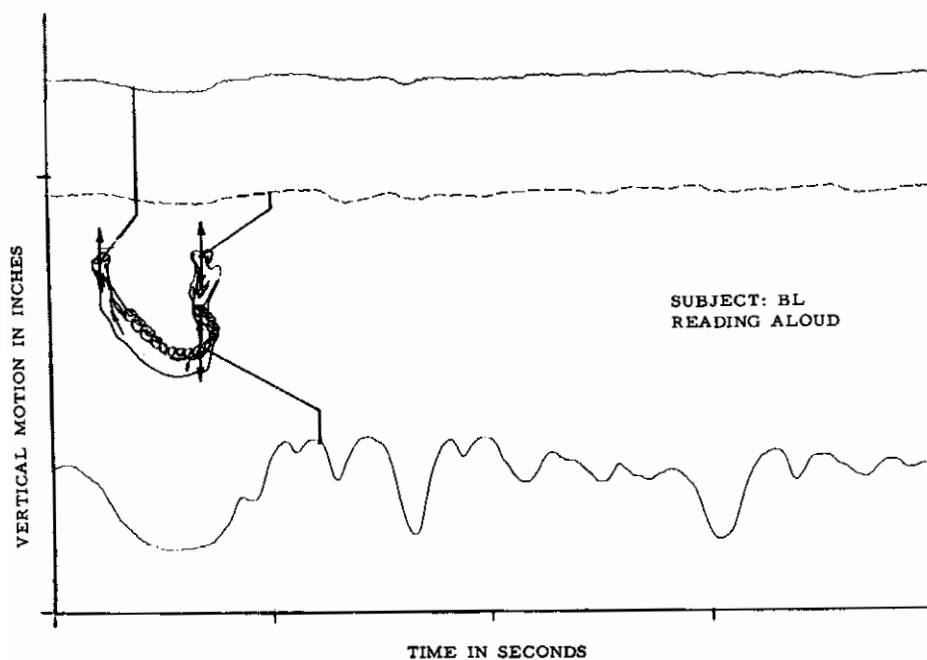

FIGURE 6. Vertical motion of the central incisor and condyles vs time for a subject with ideal occlusion reading aloud.

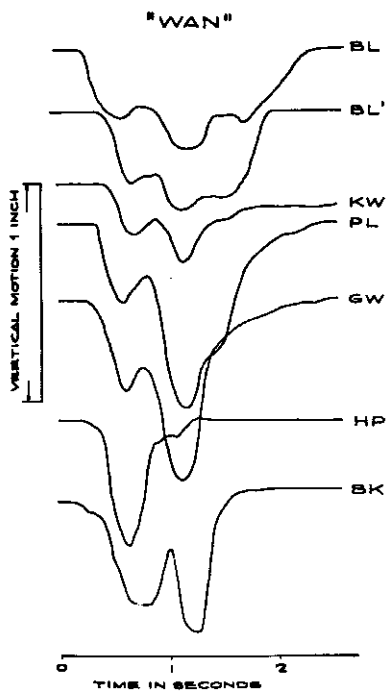

FIGURE 7. Vertical motion vs time of the central incisor for six subjects pronouncing *wan*.

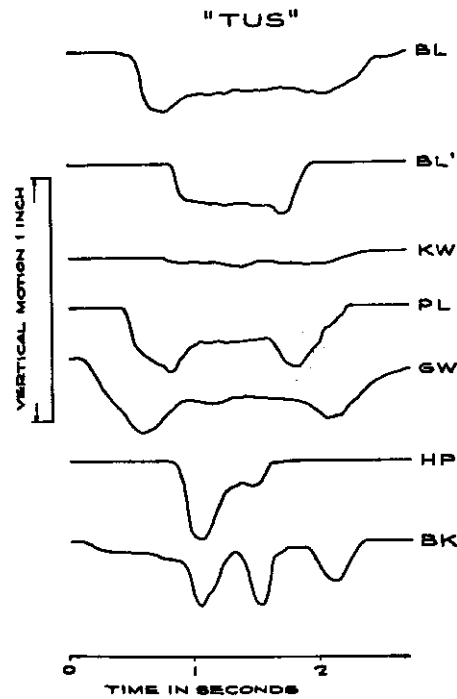

FIGURE 8. Vertical motion vs time of the central incisor for six subjects pronouncing *tus*.

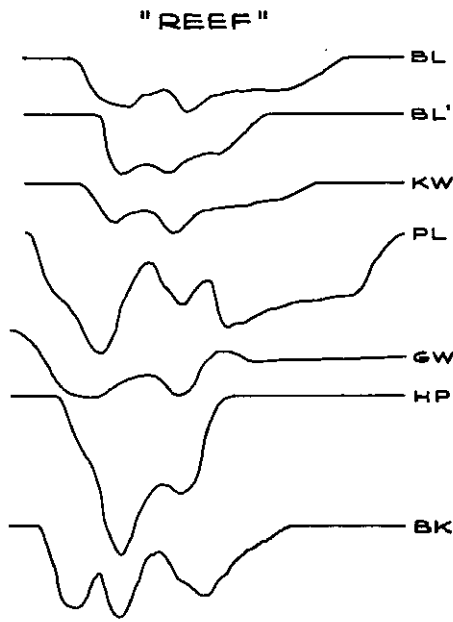

FIGURE 9. Vertical motion vs time of the central incisor for six subjects pronouncing *reef*.

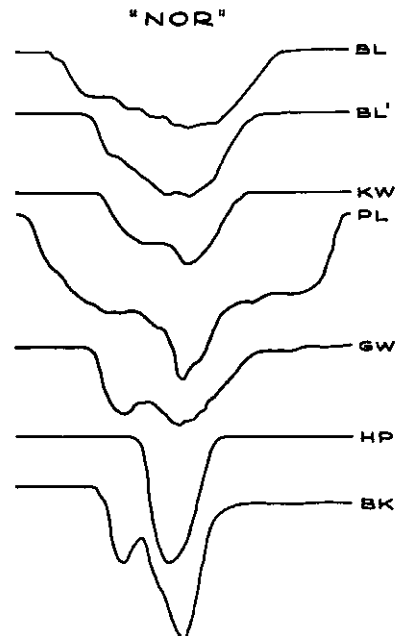

FIGURE 10. Vertical motion vs time of the central incisor for six subjects pronouncing *nor*.

by Snider (1967). Subject BK was unusual in that he had sustained a bilateral jaw fracture at the neck of both condyles.

#### DISCUSSION

This preliminary study showed that there is less jaw motion, especially laterally, during speech than during chewing; however, by percentage, horizontal motion is greater during speech. This indicates that much important speech data could be obtained by concentrating on measuring vertical and horizontal (planar) motion exclusively.

Assuming planar motion and a known condylar path, vertical and horizontal motion during speech could be measured with a less complex two-degrees of freedom system. Since lateral motions and variations in the condylar path are small, future research into speech motion seeking to measure all jaw motions simultaneously will require a six-degrees of freedom system with high precision, such as our system.

The vertical motion versus time plots of four special words—*wan*, *tus*, *reef*, and *nor*—to a degree are distinguishable by visual inspection. Normalization and correlation techniques may be used on the data for vertical and horizontal motion to produce additional means of recognizing the separate words. This preliminary research indicates that certain words may be distinguishable by machine. Perhaps jaw motion during speech would be useful to paralyzed persons in controlling devices such as motorized wheel chairs and artificial limbs. Jaw motions of speech could be learned easily and would be independent of environmental sounds.

#### ACKNOWLEDGMENT

This project was sponsored by the Public Health Service under the Department of Health, Education, and Welfare (Grant Number DE 03500).

#### REFERENCES

- CANNON, D. C., RESWICK, J. B., and MESSERMAN, T., Instrumentation for the investigation of mandibular movements. Report No. EDC 4-64-8, Engineering Design Center, Case Western Reserve Univ., Cleveland, Ohio (1964).
- GIBBS, C. H., RESWICK, J. B., and MESSERMAN, T., The Case Gnathic Replicator for the investigation of mandibular movements. Report No. EDC 4-66-14, Engineering Design Center, Case Western Reserve Univ., Cleveland, Ohio (1966).
- GLICKMAN, I., PAMEIJER, J. H. N., and ROEBER, F., Intra-oral occlusal telemetry, Part I: A multifrequency transmitter for registering tooth contacts in occlusion. *J. pros. Dent.*, 19, 60-68 (1968).
- SNIDER, D. L., Derivative analysis of speech contour for voice recognition. Ph.D. dissertation, Case Western Reserve Univ. (1967).
- SZYMANSKI, T. G., The processor concept for computer analysis of jaw motion data prepared for the Case Gnathic Replicator. Engineering Design Center, Case Western Reserve Univ., Cleveland, Ohio (1968).

## SPEECH MEASURES OF OROFACIAL FUNCTION

FRANK R. KLEFFNER

*Central Institute for the Deaf, St. Louis, Missouri*

There is virtually nothing to add to this topic beyond what Bradley and Noll presented in *ASHA Reports Number Five*. Bradley (1970) thoroughly reviewed current knowledge about oromuscular function in speech. Noll (1970) comprehensively covered the assessment of articulation, the speech measure most logically related to orofacial function. Since both of these papers are thoroughly documented, I refer you to them for references to the primary resources of research publication and clinical observation which comprise most of the fundamental knowledge and concepts regarding the relations between speech function and orofacial function.

My purpose in this presentation is to provide an overview of the concepts and issues which are pertinent to the clinical technology of the speech pathologist in his efforts to measure speech performance, with particular reference to orofacial function. Details of the technology of speech measures and documentation of the knowledge base for this technology will not be provided in this paper. A further limitation is that my presentation will give attention to those measures which depend on the speech pathologist's function as an expert judge of a speaker's performance during the act of speaking rather than to measures which require specialized hardware or instruments.

Four fundamental considerations must be taken into account in any discussion of speech measures. The first is that speech is a mode of linguistic transmission and, as such, it is both a product of and a portion of the speaker's linguistic capability. Speech performance as a mode of linguistic transmission manifests linguistic rules and requirements through the capabilities and limitations of the structures and functions of the speech production mechanisms. The influences of orofacial function on human speech behavior are subordinate to the influences of the linguistic code.

The second is that the most valid source of information regarding one's ability to talk is direct observation of the act of speaking. Although elaborate and sophisticated instruments and methods have been developed to study various aspects of the anatomy and physiology of the speech mechanism, these measures and instruments are not adequate substitutes for direct observation of the speaking act. Only in cases of relatively gross deviations or inadequacies of

sensory, motor, or physiologic function, or marked anatomic deviations, can we adequately infer speech proficiency without actually hearing the speech. Even then experience has taught us that we must validate such inferences by directly observing the speech act, since the human appears to be abundantly endowed with motivation, social and emotional need, and intellectual and physical capability for developing functional verbal communication abilities in spite of apparently significant impairments of one or another aspect of the speaking mechanism.

The third is that, in spite of the availability of sophisticated instrumentation, there are as yet no satisfactory methods for evaluating most aspects of speech performance which do not depend on the judgments of human listeners. Only the human listener can judge adequacy or describe variations in speech performance. The speech pathologist, of course, is considered to be an expert trained in making such judgments.

The fourth of these fundamental considerations is that although existing measures of speech ability provide descriptive information regarding deviations or variations in speech behavior they do not measure the degree of handicap. At best, we can only infer the degree to which any deviation from the norm in speech performance constitutes a true handicap to the speaker's social, emotional, academic, or economic attainment. Inadvertently, speech pathology has appeared to be in the position of equating variation with handicap. That this is naive, if not outright erroneous, is apparent in the extent to which the general public fails to perceive the same magnitude of need for the services of speech pathologists that speech pathologists project for themselves.

The totality of human verbal behavior requires that we view measures of speech performance within a perspective which at least includes reference to the assessment of hearing, voice production, and linguistic ability. These aspects of verbal communication are sufficiently interrelated that a measure of one ability is likely to have immediate and direct relevance to the others. Consequently, each will be considered at least briefly, to provide the perspective necessary for optimal appreciation of the significance of measures of the phonologic features of speech.

#### MEASURES OF HEARING

In the normally developing human, speech is "controlled by the ear." Infants from the beginning of life develop a dependent relation between the auditory receptive mechanism and the vocal-speech production mechanism. An infant's vocalizations begin early to show a distinguishable resemblance to the speech patterns they hear. Adult listeners, native speakers of a given language, can differentiate the vocalizations of infants seven to nine months of age exposed to the listener's language from the vocalizations of infants exposed to languages not native to the listener. Serious hearing impairment from birth interferes with all aspects of a child's learning of language. In contrast, however, when hearing is impaired after language and speech have been acquired, the levels

of linguistic competence already established will not be lost, even though the understanding of speech which is dependent on auditory capacity may be influenced adversely. Also, if the talker is deprived of auditory cues in monitoring his own speech, his control of speech performance will likely suffer. Clinical observation and research provide evidence that the effects of serious hearing impairment alter a number of aspects of orofacial function in speech. These effects are seen in slower speaking rates, reduced or deviant vocal intonation features, and the patterns of muscular activity of the tongue, lips, and jaw in articulation. Generally, the speech of the hearing-impaired talker is less accurate and more exaggerated. Electromyographic data comparing the speech of the deaf and normally hearing talkers has supported these clinical impressions (Huntington, Harris, and Sholes, 1968).

The most pertinent measures of hearing with respect to the reception of verbal communication are measures of auditory sensitivity and measures of speech reception. The audiometer, the primary instrument for testing auditory sensitivity, produces pure tones (single frequencies) in which frequency and intensity can be varied independently. This instrument permits threshold measures to be obtained for each ear at all frequencies within the range of human hearing. Though pure-tone tests provide important information regarding hearing, they do not provide adequate information regarding speech reception capability. Speech is also used as a stimulus in testing hearing because it has greater face validity than pure tones for determining speech reception ability, degree of handicap, and value in the use of a hearing aid. Speech reception thresholds provide information about the degree of loudness required for speech to be recognized. Tests of speech intelligibility provide measures of the hearer's ability to understand speech produced by normal talkers. In this context, intelligibility refers to the intelligibility of normal speech to the hearing-impaired subject. Some of the tests used in speech audiometry comprise lists of words selected to reflect the distribution of the sounds of the English language. These measures, though still important tools of the audiologist, are not as valuable as once thought; new knowledge about the lability of the phoneme and the effects of linguistic variables on speech reception make it necessary to interpret the results cautiously. Consult Davis and Silverman (1970) for comprehensive coverage of all aspects of hearing impairment.

#### MEASURES OF SPOKEN LANGUAGE

Informed reference to speech measures requires our full acknowledgment of the role of speech as a mode of linguistic transmission and requires us to recognize that measures of speech ability can serve as measures of linguistic ability. Many measures of linguistic ability are based on analysis of the verbal utterances of a speaker. Among the types of analyses made of verbal utterance are measures of length of utterance, vocabulary usage, word order, ratio of different words to total words, sentence complexity, quality and variety of syntactic structure, and prosody features. Speech utterances constitute an essential

part of the data on which to base any estimates of linguistic competence. No effort to assess language ability is complete without an assessment of spoken utterance. Further, speech performance always reveals the influences of the speaker's linguistic competence just as it may reveal information about his anatomical and physiological capabilities.

#### MEASURES OF VOICE

Attention to speech production implies or includes attention to vocal production. Primarily, of course, measures of vocal production give attention to the functions of the larynx, although resonance features which are not laryngeal are included. While orofacial function is not directly pertinent to the laryngeal aspects of vocal production, it is relevant to vocal resonance features, particularly those associated with oral-nasal-pharyngeal structures and functions. Generally, measures of vocal production have proved more difficult to standardize and objectify than measures of phonologic ability. Further, velopharyngeal incompetencies which influence voice also influence articulation and the relative effects are difficult to separate. Effects of vocal resonance and articulation are related to ratios of volume of oral cavity to nasal cavity, size of velopharyngeal port, direction and volume of airflow, and other concomitants of the physical communication and valving between the oral and the nasal passages. In any attempt to analyze the vocal resonance associated with velopharyngeal inadequacy, the judgments of the vocal features are easily contaminated by the quality of articulation and the intelligibility of the speech. That is, when there are obvious errors in consonant articulation, or when speech is unintelligible, listeners tend to judge vocal quality toward the hypernasal end of the scale. In efforts to improve the reliability of judgments of nasality, tape-recorded samples of degrees of hypernasality have been used as a standard for calibrating the judgments of listeners. Another technique is to tape-record the speech to be judged and then play the tape backward. This approach presumes to minimize the influences of intelligibility and articulation factors and thereby allow the listener to focus more on the vocal resonance features. None of the approaches has successfully eliminated the problems related to the variability of listener judgments or the difficulty in making judgments about the effects of vocal resonance in the presence of poor articulation or intelligibility.

#### MEASURES OF ARTICULATION

Experience accumulated in speech pathology has helped us to develop considerable skill and efficiency in measuring articulation ability. Primarily, the testing of articulation is based on observation of the subject's ability to produce the sounds of the language. Most approaches to articulation testing yield an inventory of the speaker's consonant production repertoire, although some tests also evaluate vowel production. Usually testing is based on observation of the speaker's production of each sound at least once in the various positions in

which it may occur within word units (initial, medial, or final). Most articulation tests consist of stimulus materials, usually pictures, designed to elicit the production of specific words. The words to be spoken have been selected to provide the examiner one or more opportunities to hear each sound tested. Other variations which are more difficult to control, but which are considered to provide more valid information than single word utterances, are the approaches designed to elicit connected speech utterances. As might be expected, the degree of control over the sample obtained and the reliability of listener judgments diminish as the speech samples move in the direction of spontaneous utterance of connected speech. Generally, however, an experienced, trained examiner can obtain reliable results with any approach to articulation testing. Data from numerous studies of reliability of single word tests show inter- and intratester agreement to be in the 85-90% range both in detecting the presence of error and in designating the type of error. When connected utterances and spontaneous speech are used, agreement is lower, ranging from 70 to 85%. Many of the studies reporting test-retest comparisons show correlations above 0.90 (Winitz, 1969).

Tests of the type just described yield information which can be studied for patterns of errors, compared to normative data, or expressed as a single numerical value representing an error score on the inventory included in the test. Some tests have been used to obtain normative data which provides percentile scores or arithmetic means for various age levels. Such numerical values are useful for comparison with the normal, for documenting change, and for determining numerical cutoff points between adequate and inadequate performance. Since many of the commercially available tests do not include their own normative data, the examiner who wishes to interpret results in relation to normal development has no alternative but to attempt to relate the test results he has obtained to other norms which often are not expressed in terms directly applicable to the test the examiner used. Inevitably something is lost in such interpolations. Articulation test approaches which would yield an articulation age would permit useful comparisons with the results of a number of other tests which are expressed in age terms (mental age, motor age, social maturity age, language age, vocabulary age) relative to chronologic age.

A somewhat different approach to articulation testing was devised by McDonald (1964), who proposed that speech production should be viewed as a series of overlapping movements in a continuous time sequence. He questioned the assumptions underlying the testing of sounds in words in a way in which those sounds could be regarded as initial, medial, or final, suggesting instead that the unit to test was the syllable rather than the word. In the McDonald Deep Test each consonant is tested as the initiating sound in a syllable and as the terminating sound in a syllable under conditions in which the influence of adjacent sounds can be determined. In this approach, each sound is observed as many as 40 or 50 times, each time in a different phonetic context. The fact that each sound is observed many times permits the test results to be expressed in terms of percentage correct or percentage of error for each sound. This pro-



vides some insight into the relative defectiveness of sounds in relation to each other, and may suggest some therapeutic approaches by identifying phonetic contexts within which the subject's production of a given sound is more likely to be correct. Also, the percentage score for each sound is a potentially more sensitive indicator of articulation change than the types of data yielded by the tests described earlier.

Other variations in articulation testing reflect the purposes of such testing. In some clinical activities an abbreviated sample of articulation may be obtained for screening purposes. In these approaches, no effort is made to obtain a full inventory of the speaker's control of the sounds of the language. Instead, testing is restricted to those items which are most sensitive in distinguishing between adequate and inadequate articulation performance. Screening tests often can be completed in under five minutes. In contrast to screening tests, diagnostic testing of articulation ability might have the more extensive purpose of identifying causes and prescribing the nature and focus of a remedial program. Testing of this kind is more tedious, often requiring several testing sessions in order to avoid fatigue, for subject and examiner. Diagnostic testing usually includes the collection of detailed information about the subject's ability to produce a wide range of sounds in a variety of types of utterance and in a variety of phonetic contexts.

Some articulation testing is conducted to obtain developmental data or establish normative data. Testing for these purposes might require additional or different sampling of speech production behavior from that necessary to establish a diagnosis for clinical remedial purposes.

A few testing approaches have been based on collecting restricted samples of an individual's phoneme repertoire to predict the need for therapy or to evaluate progress in therapy. Such approaches are in some respects similar to screening testing, in that the restricted set of test items includes only the items most sensitive in identifying subjects who will progress rapidly or slowly, or who will or will not need therapy in order to progress.

Finally, some restricted sets of test items are designed to assess some particular aspect of total articulation capability. The Iowa Pressure Test (Morris, Spriestersbach, and Darley, 1961) is such a test. This test is composed of a selection of words containing sounds which are highly dependent on the adequacy of velopharyngeal closure.

One additional feature in testing articulation is to test the subject's stimulability (Milisen, 1954; Goldman and Fristoe, 1969). In testing stimulability the tester provides a spoken model for the subject to imitate. The tester can vary the kind and intensity of stimulation in the model to observe the relative effects of such stimulation on the subject's imitative response. Testing for stimulability is at least a part of what any clinical appraisal of articulation ability might include. Almost all clinicians consider observations of this kind to provide important information on which to base clinical judgments and predictions. Stimulability tests have not been standardized or systematized to the same extent as tests of sounds in words using picture stimuli.

## SPEECH DEFECTS AND OROFACIAL FUNCTION

The history of speech pathology shows a steadily accumulating literature which documents the search for the relations among speech performance, anatomy, and physiology. Many of the specific investigations in that continuing search have focused on particular aspects of orofacial structure and function. The investigations have been varied and the findings often have appeared disparate, if not actually contradictory. The number of potentially significant variables which intrude into the interactions among speech, anatomy, and physiology makes it difficult to draw useful comparisons from one study to another and compels any summarizer to generalize cautiously. An inverse relation appears to have been established, however, between the accumulation of knowledge regarding defective development of speech and the significance accorded to the influences of orofacial musculature and function. Continuing study of the interactions among speech performance, anatomy, and physiology has steadily advanced our knowledge about speech defects and has led to an equally steady decrease in the causal significance we can ascribe to orofacial factors. See Winitz (1969, pages 139-235) for a comprehensive and detailed analysis of research literature relating speech behavior to physical factors and other variables.

In obvious orofacial pathologies such as clefts of lip and palate or muscular impairment there are clear cause-and-effect relations between organic factors and speech behavior. Even in such cases, however, the organic pathologies cannot account for all the speech deviations observed (Phipps, 1965; McWilliams, 1970). Also, there are indications that degree of defectiveness or amount of improvement in speech is subject to influences other than physical factors.

### *Motor Abilities*

A number of efforts have been made to determine whether or not poor development of speech articulation results from some generalized motor disability. The hypothesis that there is such a generalized motor deficit has not been supported. More detailed efforts have been made to determine whether poor articulation may result from poor function of orofacial musculature. While some evidence indicates that speech defectives are less capable than normal speakers in certain orofacial movements, there has been insufficient study of orofacial movement patterns which are free of the speaker's experience in producing sounds. As a consequence, we can say little more than that in tests of speech movements speech defectives as a group show poorer performance than normal speakers. The circularity of this reasoning is obvious, and until there are more detailed studies of orofacial muscular ability in nonspeech movements, our knowledge must be considered inconclusive.

### *Oral Structures*

Measures of dental deviations, particularly of alignment and occlusion, show

a low positive concomitance of deviant dental structure and deviant speech. Causal relationships between dental deviations and speech deviations have not been shown. Many measures of the physical features of palate, tongue, lip, and dental arch formation have been analyzed in relation to speech measures. Except in obvious oral pathologies, little relation has been shown.

#### *Oral Sensation and Perception*

Investigations of various aspects of oral sensation and perception have provided much new information about orofacial function (Ringel, 1970). As is true in many new areas of investigation, much of the early research has contributed more to the development of the research technology than to knowledge about the subject. Concepts about kinesthesia, proprioception, and tactile sensation in relation to oral function and speech have been given a more sharply defined place within the perspective of our total knowledge about speech performance. Thus far, the study of oral sensation and perception has not added as much to our insight about etiology and pathology as some had hoped. As the methods and instrumentation for the study of oral sensation have been developed, it has become clear that some aspects of oral sensation and perception are not more related to speech performance than others. There is value in studying the oral sensory abilities of persons with defective speech, to appropriately modify therapy when oral sensory deficiencies are present.

#### *Other Considerations*

Deficiencies in auditory memory span and auditory discrimination abilities (in persons with normal auditory sensitivity) have been hypothesized as contributing to poor speech development. Since many of the variables which can influence auditory perception have not been well determined, studies have lacked adequate control. Further, children vary greatly in their responses to the types of tests which have been used, particularly tests of auditory memory span and auditory discrimination. The findings in these areas have been either ambiguous or inconclusive and do not suggest clear hypotheses for future investigations.

A consistent finding in persons with defective speech is that, as a group, they show generally poor ability in lexical and grammatical aspects of verbal performance. Speech defectives when compared with normal speakers tend to do less well on vocabulary tests, use shorter sentences, and make more grammatical errors. Whether findings of this kind can be better interpreted as relating to the causes or the consequences of speech defects remains unanswered. Clearly, there are complex possibilities in the dynamics of the psychosocial impact of obviously deviant verbal communication behavior. There is some rationale for proposing that a reduced capacity to produce accurate or intelligible speech might have a generally depressing effect on other aspects of verbal development. Conversely, another equally rational observation is that

speech defectives as a group tend to perform less well on many kinds of tests, not necessarily related to speech.

### *Cleft Palate*

Palatopharyngeal structure and function are more significantly related to speech performance than any other musculature or structure in the orofacial complex. Palatopharyngeal defects can impair articulatory and vocal resonance features of speech production and indirectly may cause the speaker to develop deviant orofacial muscular functions in his compensatory efforts. Speakers with cleft palate show differences from normal speakers in their palatal and pharyngeal muscular function, linguopalatal contact, and linguapharyngeal contact. Any palatopharyngeal defect significant enough to affect speech will have concomitant effects on articulation and vocal resonance. There is a high correlation between palatopharyngeal function and normal articulation and voice quality. Nonnasal voice production requires more adequate velopharyngeal closure than does accurate consonant articulation. The negative effects of inadequate velopharyngeal function are greatest for continuant consonants; unvoiced consonants are affected more than voiced ones, and plosive consonants are affected least. With regard to the adequacy of velopharyngeal closure, there appears to be a critical point beyond which both vocal resonance and articulation features will show obvious adverse effects.

There are some indications that the adequacy of velopharyngeal closure is more essential to developing than to maintaining good articulation. Some of the investigations of speech therapy for cleft palate have illustrated the complexity of the interactions between structure and function. Therapy has been reported to have produced improvement in palatopharyngeal closure patterns. There also have been reports that speech therapy has improved speech intelligibility, in some instances without evidence of improving the function of the palatopharyngeal valve. Cinefluorographic observations have shown instances in which palatopharyngeal closure has not changed, even though articulation has improved. Shelton (1970) presents a review and critical analysis of studies of various remedial approaches to cleft palate.

When orofacial function for speech is inadequate because of cleft palate, the effects appear generally to depress social-linguistic development. Children with cleft palate tend to show generalized deficiencies in a number of aspects of language. This retardation of language development probably is a consequence of the combined difficulties these children encounter in attempting to speak intelligibly and the negative influence of facial appearance on their self perception and social success (Spriestersbach, 1965).

### *Summarizing Generalizations*

(1) Many of those with defective speech show depressed levels of performance on a variety of tests of nonspeech abilities, suggesting the presence of

disabilities which are sufficiently generalized in their effects that their influences are not confined to the interactions between speech production and orofacial function. (2) Speech which is sufficiently defective to impair intelligibility may produce generalized effects of its own through inhibiting or retarding influences on the speaker's social-linguistic development. (3) Most orofacial defects significant enough to interfere with speech will interfere with more than articulation ability. (4) There is sufficient strength in the combined social-emotional and intellectual capacities of humans to learn verbal communication that the effects on speech of most deviations of orofacial structure or function are minimal. (5) Poor development of articulation in the absence of obvious mental or physical pathologies should be viewed as faulty learning of the phonology of the language rather than as a consequence of faulty orofacial function.

#### SPEECH DEFECTS AND DISTINCTIVE FEATURE ANALYSIS

More than four decades of clinical work and research have made it clear that few fruitful insights into the nature and treatment of speech disorders are to be expected from continued study of the relation between speech production abilities and orofacial function. Though the search for the organic correlates of defective speech will not be abandoned entirely, it is likely to be largely replaced by an expanding search for linguistic correlates. The linguistic concept of distinctive feature analysis offers powerful possibilities for reorganizing and reinterpreting our present knowledge about speech production into new clinical applications and new hypotheses for research.

Much of our phonologic training in speech pathology has reflected knowledge about distinctive features. We have long classified sounds by their place of articulation, voicing, and manner of release. These are distinctive features. There are others. Phonologists have identified between nine and 12 distinctive features which presumably are adequate to specify the characteristics of the phonemes of all languages. A distinctive feature analysis of phonemes produces a description of each phoneme according to the presence or absence of each distinctive feature. Just as there are economies in viewing the acoustic events of a language by phonemes rather than word by word, there are similar advantages in viewing the phonemes of the language in terms of the significantly smaller number of distinctive features. The 45 or 46 sounds of English can be described adequately and economically in terms of 9 or 10 distinctive features which are combined in various ways for each sound. Each sound of a language is different from all the other sounds in that language in one or more of the distinctive features.

There are appealing possibilities in the intellectual economy the distinctive feature concept can introduce into our clinical and research efforts. Crocker (1969) points out how a child's learning of the sounds of the language represents a systematic progression in acquiring control over distinctive features in which the mastery of later sounds depends on the child's level of competence

with the features included in the sounds learned earlier. Those sounds learned latest, and particularly those which are most likely to develop defectively—such as /s/, /r/, and /l/—are sounds which have the most complex combinations of distinctive features. For many years, the patterns of speech errors of children with defective articulation have caused us to think of such disorders as being characterized by inconsistency. When considered from the point of view of distinctive features, however, orderly patterns often begin to emerge from what might otherwise have appeared to be a scatter of unrelated errors. Compton (1970) suggests that in studying the child with a speech defect we should assume that that child has developed a coherent system for using sounds and that the defects he shows can be better understood if a serious effort is made to discover the phonetic rules and principles governing his speech behavior. Compton further suggests that therapy should be directed toward changing or elaborating the phonetic principles underlying the child's speech rather than toward correcting sounds. Weber (1970) analyzed the patterns of deviant articulation in 18 children. He was able to show general principles or rules governing each child's speech behavior. There were from one to six patterns for each child, with most of them showing two or three. The relatively small number of patterns accounted for large numbers of errors and suggested promising simplifications over the more traditional sound-by-sound approaches to therapy.

The study of normal development of speech and approaches to therapy seem likely to benefit from applications of the distinctive feature concept. By applying this concept, we can interpret the child's speech development or his failures in speech development according to the rules that determine his phonologic behavior. This approach will enable us to determine where he is in the sequence of learning English phonologic rules. For the child with defective speech, we can organize our therapy to help him proceed from the rules which appear to govern his pattern of errors on into mastery of the remaining rules of the English phonologic system.

#### PROJECTIONS FOR THE FUTURE

Our approaches to testing speech, particularly articulation, are bogged down by the degree to which we have become committed to testing sounds in single word utterances. Though some efforts have been made to break from that tradition, no significant steps have been taken toward developing a technology for testing speech in spontaneous utterance. Recent studies further emphasize the need to expand articulation testing beyond the observation of sounds in words. The effects of coarticulation (the influence of adjacent sounds on each other) has been shown to extend over as many as four or five contiguous sounds (Daniloff and Moll, 1968). Faircloth and Faircloth (1970) made phonetic and spectrographic comparisons of a child's speech during single word utterances and connected speech. They found measurable differences for each word analyzed under the two conditions. The testing of articulation in single word

utterances simply is not a valid enough speech measure to continue to be of major value.

The growth of consumerism and the demand for accountability in education, health, and social service make it urgent that we seek means to measure the degree of handicap associated with the variations in speech behavior which we are able to measure. We need to be able to describe the significance of patterns of deviant speech behavior in terms which have meaning outside our professional circles. Though our knowledge base has grown steadily and though the prospects for even greater advances in the future appear good, we remain vulnerable in times when public support for costly forms of service can no longer be taken for granted. Discussions of syntax, phonology, or distinctive features will not validate the need for continued public or private support of clinical services or research.

As our knowledge of normal speech development and speech defects increases, it also becomes increasingly important for us to develop techniques for differentiating between speech deviations which will improve spontaneously and those which need therapeutic intervention. Some promising initial efforts have been made (Van Riper and Erickson, 1969), but others must follow in order to help document the value of clinical speech services and the efficiency of the utilization of those services.

Finally, a parting comment on the subject of this presentation, "Speech Measures of Orofacial Function." My underlying theme has been to stress the lack of reciprocal benefits between measures of speech ability and measures of orofacial function. I do not believe that the study of orofacial function can shed much light on our knowledge about speech, nor that the study of speech will enlighten regarding orofacial function. I do believe that as we increase our knowledge about speech we increase our knowledge about all aspects of human verbal communication and vice versa. Speech is a function of language, should be viewed as such, and will be understood best within that context. Having expressed this point in my own words in several ways, I will close with a quotation from MacNeilage and DeClerk (1969) which expresses what I believe to be the essence of the relation between speech and orofacial function: ". . . the speech production process is not an inefficient response to invariant central signals, but an elegantly controlled variability of response to the demand for a relatively constant end."

#### REFERENCES

- BRADLEY, DORIS P., Muscular functions of the dentofacial milieu: Speech. *Proceedings of the Workshop Speech and the Dentofacial Complex: The State of the Art. ASHA Reports Number 5*. Washington, D.C.: American Speech and Hearing Association, 76-91 (October 1970).
- COMPTON, A. J., Generative studies of children's phonological disorders. *J. Speech Hearing Dis.*, 35, 315-339 (1970).
- CROCKER, J. R., A phonological model of children's articulation competence. *J. Speech Hearing Dis.*, 34, 203-213 (1969).
- DANILOFF, R., and MOLL, K., Coarticulation of lip rounding. *J. Speech Hearing Res.*, 11, 707-721 (1968).

- DAVIS, H., and SILVERMAN, S. R., *Hearing and Deafness*. Chicago: Holt, Rinehart (1970).
- FAIRCLOTH, M. A., and FAIRCLOTH, S. R., An analysis of the articulatory behavior of a speech-defective child in connected speech and in isolated-word responses. *J. Speech Hearing Dis.*, 15, 51-61 (1970).
- GOLDMAN, R., and FRISTOE, M., *Test of Articulation* (Manual). Circle Pines, Minn.: Amer. Guid. Serv. (1969).
- HUNTINGTON, DOROTHY A., HARRIS, KATHERINE S., and SHOLES, G. N., An electromyographic study of consonant articulation in hearing-impaired and normal speakers. *J. Speech Hearing Res.*, 11, 147-158 (1968).
- MACNEILAGE, P. F., and DECLERK, J. L., On the motor control of coarticulation of CVC monosyllables. *J. acoust. Soc. Amer.*, 45, 1217-1233 (1969).
- MCDONALD, E., *Articulation Testing and Treatment: A Sensory-Motor Approach*. Pittsburgh, Pa.: Stanwix House (1964).
- MCWILLIAMS, BETTY JANE, Psychosocial development and modification. *Proceedings of the Workshop Speech and the Dentofacial Complex: The State of the Art. ASHA Reports Number 5*. Washington, D.C.: American Speech and Hearing Association, 165-187 (October 1970).
- MILISEN, R., *The Disorder of Articulation: A Systematical Clinical and Experimental Approach. J. Speech Hearing Dis. Monogr. Suppl. 4* (December 1954).
- MORRIS, H. L., SPRIESTERSBACH, D. C., and DARLEY, F. L., An articulation test for assessing competency of velopharyngeal closure. *J. Speech Hearing Res.*, 4, 48-55 (1961).
- NOLL, J. D., Articulatory assessment. *Proceedings of the Workshop Speech and the Dentofacial Complex: The State of the Art. ASHA Reports Number 5*. Washington, D.C.: American Speech and Hearing Association, 238-298 (October 1970).
- PHIPPS, G. T., Psychosocial aspects of cleft palate. *Proceedings of the Conference Communicative Problems in Cleft Palate. ASHA Reports Number 1*. Washington, D.C.: American Speech and Hearing Association, 103-111 (April 1965).
- RINGEL, R. L., Oral sensation and perception: A selective review. *Proceedings of the Workshop Speech and the Dentofacial Complex: The State of the Art. ASHA Reports Number 5*. Washington, D.C.: American Speech and Hearing Association, 188-206 (October 1970).
- SHELTON, R. L., Modification of oral-facial function during speech. *Proceedings of the Workshop Speech and the Dentofacial Complex: The State of the Art. ASHA Reports Number 5*. Washington, D.C.: American Speech and Hearing Association, 146-164 (October 1970).
- SPRIESTERSBACH, D. C., The effects of orofacial anomalies on the speech process. *Proceedings of the Conference Communicative Problems in Cleft Palate. ASHA Reports Number 1*. Washington, D.C.: American Speech and Hearing Association, 111-128 (April 1965).
- VAN RIPER, C., and ERICKSON, R., A predictive screening test of articulation. *J. Speech Hearing Dis.*, 34, 214-219 (1969).
- WEBER, J. L., Patterning of deviant articulation behavior. *J. Speech Hearing Dis.*, 35, 135-141 (1970).
- WINITZ, H., *Articulatory Acquisition and Behavior*. New York: Appleton (1969).



## CASE PRESENTATION AND DISCUSSION<sup>1</sup>

H. HARLAN BLOOMER

*University of Michigan, Ann Arbor, Michigan*

A television-taped demonstration has been prepared of the treatment Brien Lang and I devised for a postbulbar polio patient four years ago. The video tape has not been shown before. It is an experimental portrayal of the cooperation of a speech pathologist and a dentist in solving a clinical problem through joint professional effort. Specifically, it demonstrates construction of a lift appliance for a patient whose palate was paralyzed by an attack of bulbar polio several years ago. The conferences and procedures demonstrated are similar to those we have used in many of our clinical conferences involving appliance construction for patients with palatal incompetence or insufficiency.

In 1952, the late Paul Gibbons of the University of Michigan Dental School and I were faced with the problem of devising a treatment procedure for a comparable patient whose palate was paralyzed by an attack of polio. In an experimental approach to management of his palatopharyngeal incompetence, we devised the prototype of what has come to be known as the "lift appliance." Incidentally, that man, 19 years later, is still wearing a palatal lift appliance, with no signs of extruded teeth or inflammation of the oral mucosa. Its beneficial effects on speech enabled him to complete a college education in business administration and to be employed successfully. Since then, many of these appliances have been built in the prosthodontics clinic.

Lang and I put together this video tape in a day's time. It has had a minimum of editing. We also made a video-taped fluoroscopic record of the patient's speech, but unfortunately, due to equipment failure, the tape was of poor quality and cannot be shown.

The video tape presents the case of a 55-year-old man for whom a program of prosthetic treatment was evolved to enable him to compensate for a hypernasality which had been seriously handicapping to his employment as an administrator. His palatal paralysis was caused by bulbar polio, which had affected his palatopharyngeal function and, to a minor extent, his phonation and articulation. This patient has worn a lift appliance successfully for several years.

---

<sup>1</sup>This paper consisted of a TV-taped case presentation by H. Harlan Bloomer followed by a discussion of the case by the conference attendants. Richard Cole was session chairman.

The demonstration simulates the steps which were followed in constructing a lift appliance: (1) initial clinical evaluation by the prosthodontist (Lang) and the speech pathologist (Bloomer); (2) dental preparation; (3) speech recordings and analyses of speech qualities and intelligibility; (4) joint treatment-planning conference and data review; (5) prosthetic preparation, installation, evaluation, and modification; (6) appliance installation and summary of posttreatment assessment; and (7) patient's comments and evaluation of the treatment program.

The Joint Committee on Dentistry and Speech Pathology-Audiology commissioned the TV demonstration with the support of a grant from the National Institute of Dental Research to pay for the tape. The University of Michigan Dental School and the University Speech Clinic provided television time, technical personnel, and professional direction. It is an experimental production intended to demonstrate an activity in which two members of the related disciplines cooperate in a diagnosis and treatment program which neither member could have completed successfully if working alone. It was made with the expectation that such a demonstration may suggest other situations in which interdisciplinary clinical cooperation can be effected.

#### DISCUSSION

*Cole:* Are there comments or questions?

*Wertz:* This case presents a flaccid disarthria—lower motor neuron involvement resulting in imprecise consonants, hypernasality, and breathy voice quality. The palatal lift accounts for the reduced nasality and, probably, speech therapy helped him improve his articulation. However, I also heard an improvement in the breathiness. How do you account for this?

*Bloomer:* This improvement developed over the years. A similar change occurred in the first bulbar polio patient that we had. He had almost no control of the larynx when he started, couldn't even keep fluids out of his larynx. In time, this repaired itself, so that he acquired a fairly good voice and had no phonatory disability. This patient's voice is still slightly breathy, but, for all practical purposes, it is effective. There has been some normalizing reparative function, but I don't know whether it's because only one vocal fold was damaged and the other one compensates for it, or what happens.

*Wertz:* We seem to be hearing that he was a mouth-breather with the lift in place.

*Bloomer:* Yes.

*Wertz:* Does that account for the inhalation noise?

*Bloomer:* Yes. He was doing that.

*Wertz:* Finally, did you find it necessary to reduce the length of this patient's lift? Some cases require a reduction in their lifts. Initially, the lift fits fine

and the patient's speech improves. However, he may return and complain that the lift is too long and ask that the length be reduced. In some cases, several refittings are necessary. It almost appears that the lift stimulates some additional function. Have you noticed this in your patients?

*Bloomer:* We have noticed some return of function, to the extent that two patients could give up the appliance completely after two or three years of wearing it. Yes, modification may be necessary in response to a patient's return of function.

*Aten:* An exciting topic would be the relationship between changes in different functions with and without the lift. We have seen cases where we speculate, clinically, that nothing will be accomplished other than the patient will no longer be as hypernasal when wearing his lift. However, he now phonates in a different way, but without any change in vocal fold strength or closure. There must be a definite, dynamic relationship in these changes.

*Cole:* Yes. I think there are substantial pieces of evidence now that there are changes other than simply a blockage of airflow and a decrease in hypernasal resonance. Investigation of these changes and elaboration of them might well be profitable.

*Ritter:* I wonder whether this tape is available for use in other centers.

*Bloomer:* I see no reason why it couldn't be. We prepared it so that it could be presented to a group like this for your comments. If you're interested, we'll see about making it available.

*Kapur:* Did the patient have any problem in swallowing?

*Bloomer:* No, I don't recall that he did. Not at the time we saw him, anyway.

## COLLABORATIVE RESEARCH BETWEEN DENTISTRY AND SPEECH PATHOLOGY/AUDIOLOGY

RICHARD M. COLE

*St. Louis University Medical Center, St. Louis, Missouri*

This consideration of collaborative efforts between the professions of dentistry and speech pathology/audiology will be divided into two parts: some evidence of what has been done, and some indications of what could be done.

The survey of joint research is governed by several entirely arbitrary decisions. The survey is not intended to be exhaustive of the joint literature, but rather representative. I have chosen only works whose authors represented both fields, even though the research was collaborative. Thus, for example, relatively recent research from the University of Utah, concerned with tongue thrust, was not included since the authors were all speech pathologists. In instances where the same authors have published several articles dealing with selective aspects of a single broad topic, I have arbitrarily selected one of the articles to serve as representative, both of the authors and of the general topic. For example, Subtelny et al. have published two works concerned with pre- and postsurgical evaluations of patients undergoing pharyngeal flap surgery, in the January and July 1970 issues of the *Cleft Palate Journal*. I have included only the January 1970 article because of its somewhat broader range of subject material. Shelton et al. have published three works about pharyngeal wall activity and speech appliances, in the October 1969, January 1971, and April 1971 issues of *Cleft Palate Journal*. This survey includes only the April 1971 reference because it offers a resume of the earlier articles dealing with pharyngeal wall activity. For the same reason, only the October 1968 reference on cartilage pharyngoplasty, by Hagerty, Hess, and Mylin, appears in the survey, even though another article by them on the same general subject appeared in the April 1968 issue of *Cleft Palate Journal*. However, the same authors (Mylin et al.) reported on an entirely different subject in the July 1968 issue of the same journal, and that reference is included here. Not all of the references presented are concerned with research, per se. Some excellent articles elaborating various treatment techniques have appeared in the literature, and these references are included, as are references to articles about instrumentation and general treatises on the values of collaborative efforts between dentists and speech pathologists/audiologists.

The list of nearly 50 references would have approximately doubled if I had included all works published jointly by at least one member of the dental profession and one member of the speech pathology/audiology profession. Furthermore, a conservative guess is that the list would have more than trebled if it had included works concerned with joint clinical and research endeavors by members of either the dental profession or the speech pathology/audiology profession. It seems somewhat ironic that many of these articles have, in some fashion and to some degree, extolled the benefits of collaborative efforts between the two professions in teaching, service, and research—particularly the later two. The summary fact is that despite the arbitrary decisions which led to the limitations on the types of materials represented in this survey, the single factor which accounts most for the relative brevity of the list is the paucity of collaborative efforts between dentists and speech pathologist/audiologists as represented by the clinical and research literature.

#### SURVEY OF JOINT RESEARCH

##### *Emphasis on Interdisciplinary Efforts*

The relationship of speech pathology/audiology to dentistry is the subject of a series of articles by Lawson and Bond, one of which will be mentioned here (1968). Both the language and the topic are distinctly and refreshingly interdisciplinary, as the authors, in some detail, relate English phoneme production to orofacial structures and functions. The authors deal also with acoustic correlates of structural aberrations and of motor and sensory dysfunction. Ballard and Bond (1960) treat the importance of the relationship between the two professions, but dwell somewhat more upon articulatory deviations and the manner and degree to which they may be associated with atypical oral and facial structures and behaviors. The same subject is examined by Fawcus and Boyes (1968), who also mention the curiously contradictory research results reported in the literature about tongue thrust and oral stereognosis. They report some of their own research dealing with tests of lingual stereognosis and lingual mobility, where results showed a normal distribution of the abilities but no correlation with speech performance. In discussing oral structural deviations they conclude that "adaptation to extremely difficult mechanical and structural situations is a commonplace fact for which we see evidence every day. Martone and Black (1962), in one of the surprisingly rare articles on the subject, dwell at some length upon the applications of the findings of speech science research to full-denture prosthetics. There is little mention of the application of speech science research to the construction of cleft palate prostheses; however, on a number of occasions either speech pathologists or prosthodontists have treated this subject. I could find nothing of a similar nature relating speech science research findings to oral pathology, oral surgery, orthodontists, or pedodontics.

### *Emphasis on Anatomy and Physiology*

Over half of the articles in the "joint literature" dealing with various aspects of anatomy and physiology concern the presence, absence, or degree of palatopharyngeal closure. In most instances the subjects studied are individuals with cleft lip and palate. An increasing number of studies, however, are being devoted to the individual with congenital palatopharyngeal incompetence in the absence of overt clefting.

Graber, Bzoch, and Aoba (1959) conducted a roentgen cephalometric study of the movements of the velum and posterior pharyngeal wall in normal young adult subjects during the production of several consonant sounds. Although the study provided relatively precise data about velar and posterior pharyngeal wall activity during speech, it gave no information about a critical component in velopharyngeal closure—the mesial movement of the lateral pharyngeal walls. This fact prompted a study by Campos-Giral and Cole (1963) in which frontally oriented cephalometric radiographs were taken of subjects with cleft lip and palate wearing prosthetic speech appliances to which had been attached radiopaque coated balloons positioned in the nasopharynx. The technique provided relatively precise data about the nature, degree, and location of lateral pharyngeal wall activity. Mazaheri, Millard, and Erickson (1964) made a cinefluorographic comparison of soft palate structure and function and nasopharyngeal depth in normal subjects and in noncleft subjects with velopharyngeal inadequacy. Shelton et al. (1971) investigated differences in posterior pharyngeal wall activity in the presence of varying-sized pharyngeal bulb portions of prosthetic speech appliances.

Studies of the relationship between cranial base angle and nasopharyngeal depth have been relatively numerous and the results often contradictory. Engman, Spriestersbach, and Moll (1965) investigated this subject, comparing these dimensions in individuals with cleft lip and palate and individuals without clefts. Nasopharyngeal depth also was the subject of a recent study (Osborne, Pruzansky, and Koepp-Baker, 1971) in which a number of individuals with congenital palatopharyngeal incompetence and cervical spine anomalies were compared with a series of matched controlled subjects.

Other joint studies of anatomy and physiology include two studies of the pattern of deglutition referred to as tongue thrust. Attempts to clarify this ill-defined phenomenon were provided by Wildman, Fletcher, and Cox (1964) and by Hoffman and Hoffman (1965). (Other jointly conducted studies on tongue thrust will be presented later in this survey.) Collaborative studies of oral and nasal airflow and air pressure are rare. Notable exceptions are the studies by Subtelny, Worth, and Sakuda (1966) and Lubker, Schweiger, and Morris (1970). Equally rare are collaborative studies of motor and sensory attributes of the tongue. This is particularly curious, since the delicate transducers and measuring instruments generally employed in such studies may be shaped, positioned, and attached in a precise manner by dental specialists. Examples of joint studies in this area are provided by McGlone, Proffitt, and

Christiansen (1967) in their study of lingual pressures associated with alveolar consonants, and by Hochberg and Kabcenell (1967) and Grossman, Hattis, and Ringel (1965) in studies of oral stereognostic and oral tactile skills, respectively. Warren, Wood, and Bradley (1969) conducted a joint study of respiratory volumes during speech in normal and cleft-palate individuals.

### *Emphasis on Speech and Hearing*

The greatest number of articles under joint authorship by at least one member of the dental profession and one member of the speech or hearing profession relate to some aspect of the speech and hearing processes, but particularly the former. As was the case with articles dealing with anatomy and physiology, well over 50% of the articles about speech and hearing are concerned with the cleft-lip and palate condition and velopharyngeal incompetence. A number of articles have reported studies of the effects of surgical, prosthetic, or orthodontic treatment on oral-nasal resonance balance, articulation, and speech intelligibility. I was able to locate only one study demonstrating a collaborative relationship between dentistry and audiology. King, Reid, and Belting (1970) studied the effects of extraction and replacement of teeth on the hearing levels of their adult subjects.

Changes in articulatory proficiency following some form of dental treatment has been the subject of a number of studies. Frowine and Moser (1944) discussed various dental problems and their effects on speech, stressing the ability of most patients to adapt to unusual dental configurations and intraoral conditions in general. Rathbone and Snidecor (1959) studied phoneme production of patients before and after orthodontic treatment, and Snidecor and Kaires (1965) studied the effects of prosthetic correction of anterior open bite on the production of the /s/ and /z/. Changes in articulatory patterns following placement of a full-denture prosthesis were studied as early as 1937 by Kimball and Muyskens. Shelton et al. (1968) studied the effects on articulation of the gradual reduction of the speech bulb portion of prosthetic speech appliances. This was part of a larger investigation of the effects of speech bulb reduction on oral and nasal sound pressure levels, on cinefluorographically observed articulatory movements, and on articulation skills.

Several authors have studied changes in oral-nasal resonance balance as well as in articulation and speech intelligibility. Owsley et al. (1970) studied these dimensions in connection with patients having received superiorly based pharyngeal flaps versus those who had received inferiorly based pharyngeal flap surgery for the correction of palatopharyngeal insufficiency. The Subtelny et al. (1970) study also was of pharyngeal flap surgery, but did not distinguish between superiorly based and inferiorly based pharyngeal flaps. However, their study did include pre- and postoperative measures of intraoral air pressure and nasal airflow. Hagerty, Hess, and Mylin (1968) were interested in whether the age at which their patients received cartilage pharyngoplasty had an effect on soft palate mobility, velopharyngeal closure, and speech pro-

iciency. Rosen and Bzoch (1958) presented the general effects of prosthetic speech appliances on resonance balance and articulation. Later, Subtelny, Sakuda, and Subtelny (1966) studied the effects of the removal of speech appliances on such dimensions as intranasal pressure, intraoral pressure, speech intelligibility, and resonance balance in their cleft-palate subjects.

Studies considering primarily the presence and degree of hypernasal resonance associated with some treatment or anatomic condition are exemplified by Mazaheri and Millard (1965) in their study of changes in nasal resonance associated with the size and location of the speech bulb portion of prosthetic speech appliances, and by Starr et al. (1971), who studied the presence and degree of nasality in patients with cleft uvula.

Collaborative studies of the influence of arch characteristics on articulation skills are few. Foster and Greene (1960) reported on the incidence of maxillary arch collapse, lateral open bite, and maxillary alveolar gaps in cleft-palate children with and those without lateralized sibilant distortions. Maxillary arch dimensions, such as volume and surface area, in cleft-palate and noncleft-palate children is the subject of an unpublished study by this author, with Jill E. Cole and M. Mazaheri (1971), in which we relate these dimensions to the speech proficiency of our subjects.

Reports on the triumvirate of tongue-thrust swallow, malocclusion, and articulatory variations have appeared in the clinical literature since 1958. Curiously, few have been written jointly by speech pathologists and orthodontists. Particularly interesting is that the majority of such articles are by married couples—for example, the Hoffmans (Hoffman and Hoffman, 1965), the Janns (Ward, Malone, Jann, and Jann, 1961; Jann, Ward, and Jann, 1964), and the Subtelny's (Subtelny and Subtelny, 1962; Subtelny, Mestre, and Subtelny, 1964). These articles may provide some insight into the requisites for good reporting in this area. However, it probably would be unwise to assume that tongue-thrust research leads to marriage or vice versa.

#### *Emphasis on Treatment*

Articles written jointly by dentists and speech pathologists/audiologists with an emphasis on treatment of some form have been almost entirely concerned with cleft lip, cleft palate, and palatopharyngeal incompetence. Examples of joint studies of the surgical correction of palatopharyngeal incompetence are those by Hagerty, Hess, and Mylin (1968), mentioned earlier, and by Georgiade et al. (1969) concerning the island flap procedure for correcting cleft palate. The establishment of normal arch form and stabilization of the maxillary arch segments in patients with cleft lip and palate was the subject of an article by Mylin, Hagerty, and Hess (1968), who advocated the use of a pin-retained expansion prosthesis. Horton, Adamson, and Cooper (1964) also advocated the use of expansion prostheses in cleft-lip and -palate infants with intramaxillary collapse. The authors went on to advocate primary bone grafting of the cleft alveolus once the arch segments are properly positioned.



Several approaches have been offered for the correction of velopharyngeal insufficiency due to deficiencies in size or mobility of palatal and pharyngeal structures. Massengill et al. (1968) studied the effects of blowing, sucking, and swallowing exercises on the size of the velopharyngeal gap in patients with cleft lip and palate. A prosthetic device, somewhat similar in appearance to a palatal lift prosthesis, was the subject of a study by Lubit and Larsen (1969). The palatal portion of the appliance is inflatable and acts as a therapeutic agent in increasing the mobility and the range of motion of the soft palate during function. Gonzalez and Aronson (1970) have advocated the palatal lift prosthesis in the treatment of cases of velopharyngeal insufficiency due to anatomic and neurologic causes. Hardy et al. (1969) advocated the application of prosthetic speech appliances to the management of velopharyngeal dysfunction in cerebral palsy. The principles of construction of the appliances, their interaction with the palatal and pharyngeal musculature, and their improvement of oral-nasal resonance balance virtually are identical in selected patients with cerebral palsy and patients with cleft palate and velopharyngeal insufficiency.

#### *Emphasis on Measurement*

Few jointly written studies concerned with data recording or instrumentation systems have appeared in the literature. Those that have appeared are quite diverse in their nature and range of applicability. Millard, Balber, and Phillips (1967) developed a series of forms that constitute a data collection system for surgically evaluating cleft-lip and -palate patients. Two papers about the application of cephalometrics to cinefluorography (Sloan et al., 1964) and the application of roentgenography to the study of speech (Subtelny, Pruzansky, and Subtelny, 1957) present some of the fundamental requirements for applying roentgenography to the study of patients with speech and orthodontic problems. Subtelny et al. (1968) describe instrumentation which allows them to acquire simultaneous synchronized data from cinefluorographic portrayal of the speech mechanism during function, vocal intensity during speech, nasal and oral airflow, and oral and nasal air pressure during speech. Moller, Martin, and Christiansen (1971) have reported a technique that promises not to interfere with the function of the structure under study. There is evidence of increasing use of pressure transducers to assess lingual and buccal muscle forces during speech, mastication, and deglutition. Proffit et al. (1966) described a technique which makes possible the dynamic calibration of lingual pressure transducers. There is every reason to believe that the same technique would apply to the calibration of other pressure transducers used in the oral cavity.

#### *A Survey of the Survey*

I have cited 49 references as representative of the clinically and research-

oriented articles written by at least one member of the speech pathology/audiology profession and one member of the dental profession. At the outset of this survey I described the entirely arbitrary guidelines used in selecting these references. An examination of the references for content, authorship, and source revealed the information that follows.

*Content.* Thirty-seven percent emphasized some aspect of speech production; 29% emphasized quantification of some aspect of anatomy or physiology; 15% emphasized various treatment techniques; 11% dealt primarily with measurement systems; and 8% considered the advantages of cooperative research involving dental specialists and speech pathologists/audiologists. Fifty-three percent dealt with some aspect of the cleft-lip and -palate condition or palatopharyngeal insufficiency, congenital or acquired; and 15% dealt with tongue-thrust swallowing.

*Authorship.* Forty-two percent of the authors hold at least one dental degree, and of these approximately 44% were orthodontists and 30% were prosthodontists; 41% received their basic training in speech pathology; 20% hold the M.D. degree, alone or in conjunction with a dental degree; and 5% represent diverse backgrounds and professions, such as electrical engineering and physiology. As mentioned earlier, only one article pertained to hearing and only one author was an audiologist. Thirty-one percent of the authors appeared in two or more articles. Fourteen percent of the articles were written entirely or in part by the Subtelny's.

*Source.* Forty-five percent of the references cited appeared in the *Cleft Palate Journal*; 26% appeared in various dental journals, but primarily the *American Journal of Orthodontics* and the *Angle Orthodontist*; 18% appeared either in the *Journal of Speech and Hearing Research* or the *Journal of Speech and Hearing Disorders*; 11% appeared in journals representing a variety of professional interests.

#### SOME CONSIDERATIONS FOR JOINT RESEARCH

The foregoing survey, though limited, does indicate something of the nature and extent of the relationship between dentistry and speech pathology/audiology. While that relationship seems somewhat more than a "summer romance," to use the analogy of Flower and Lawson, one may be left with the impression that, for the most part, the relationship has been "effected on the basis of superficial glimpses of compatibility" (Flower and Lawson, 1971, p. 56). As may or may not be obvious from this survey, there are a number of issues that are both appropriate for and amenable to joint research. At least two previous papers by me (1970, 1971) have dealt with some of these issues, and I shall attempt to avoid duplication here.

The fact that 53% of the joint research literature, as represented by this survey, is concerned with cleft lip and palate and palatopharyngeal incompetence need not be troubling unless one realizes that a number of quite fundamental issues in this area remain unresolved. Warren (1970) has provided

a recent and excellent survey of treatment-oriented research in cleft lip and palate. Consequently, I shall limit my remarks in this area. There are some issues, however, that should trouble some of us since it appears that their resolution is not close at hand, and also because some writers give the impression that these same issues already have been resolved. I will elaborate on only one of these.

To use the language structure of Warren (1970) in his effective summary, some maxillary arches collapse and some do not, whether they are cleft or noncleft. The cleft arch may demonstrate intramaxillary collapse at birth or it may collapse only after lip closure. Other cleft arches may collapse after palate closure, and some never collapse. A somewhat similar condition may be seen in the noncleft patient. Buccal segment cross-bites may appear in the deciduous dentition and not in the permanent dentition, or vice versa. Some orthodontic results relapse markedly if the retainer is not worn for a day or two, while other results are quite stable though the retainers are not worn for long periods of time. The fact is that we know virtually nothing of the mechanisms predisposing to maxillary arch collapse, in the cleft or the noncleft individual. To my knowledge, only Pruzansky and Aduss (1967) have attempted systematically to account for some of the variables which may dictate whether the cleft arch will collapse or not.

During the past 17 years, an impressive number of articles have appeared in the dental and surgical literature pertaining to early maxillary orthopedics and primary bone grafting of the cleft alveolus in infants and young children with unilateral and bilateral cleft lip and palate. The rationales for either of these approaches, or the two combined, are many and varied. Basically, however, there are two assumptions underlying the use of these techniques: (1) The establishment of normal maxillary arch form early in life very likely will, in any given patient, obviate the need for orthodontic treatment of the permanent dentition, or will minimize the amount of treatment necessary; and (2) early primary bone grafting in the cleft alveolus will maintain, once it has been established, normal maxillary arch form, and will prevent intramaxillary collapse. Yet, whatever the rationale and with or without the treatment, some arches collapse and some do not.

The dilemma is considered by Pruzansky (1970, p. 168), who states that "whether you use maxillary orthopedics and/or bone grafting, or whether you do not, some cases succeed and some fail. We must now address ourselves to the question 'Why?' Never mind the percentages. Everyone knows that you do not achieve 100% success. The question 'Why' concerns mechanisms. What are the mechanisms for success and failure. Is it the kind of surgery? Is it the age at which you operate? Where is the difference?" Areas of possible difference that have not been subjected to systematic, longitudinal investigation include vascularization; the microstructure or ultrastructure of the alveolar tissues and the bony base; nerve supply to the area; and, incredibly, the differential forces of the oral, facial, and pharyngeal musculature during rest and function.

There is a paucity of carefully documented information about the influence

on speech development and articulatory proficiency of such conditions as the protruding premaxilla in cleft lip and palate, maxillary arch collapse in cleft or noncleft patients, and extreme hypertrophy of the tonsils and adenoids in cleft or noncleft patients. If we are unable, as yet, to answer the why of these conditions, we should at least be able to address ourselves to the question of whether any one of these conditions represents, in a given patient, "a difference that makes a difference." Much of this information will be provided by the collaborative efforts of speech pathologists and dental specialists, with their relatively precise records of such phenomena. But until the information is at hand, surgeons will continue to resect premaxillas, to bone graft infant alveoli, and to excise or retain hypertrophied tonsils and adenoids, with little more than their clinical intuition as a basis for doing so.

There are numerous possibilities for collaborative research between dentists and speech pathologists/audiologists. For example, let us quantify, and thereby help define, some of the entities that we so freely label, such as micrognathia and macroglossia. Let us relate the degree of movement and the tonicity of certain soft tissues, such as the lips, to arch form and articulatory proficiency. Certainly there are enough short, scarred, taut postoperative cleft lips still available to permit an evaluation of the relationships among lip function, arch form, and speech.

What are the likely consequences of retaining or removing hypertrophied tonsils and adenoids? The feelings of many orthodontists that greatly enlarged tonsils may create or at least perpetuate certain forms of malocclusion, and of otologists that adenoid hypertrophy may lead to or perpetuate chronic otitis media, stand in sharp contrast to those of some plastic surgeons who insist that tonsils and adenoids be retained out of the fear that their removal will lead to limitations of soft palate mobility or to hypernasal speech. Indeed, we have found evidence to the contrary (W. B. Slaughter, R. M. Cole, and M. Cutler, unpublished research, 1968). Removal of greatly enlarged tonsils through careful dissection may lead to an increase in velar mobility. Adenoid retention may only delay the inevitable, since resorption of this tissue is a fact of life. Roentgen cephalometry, as routinely practiced by the orthodontists, will give a relatively accurate portrayal of the location and extent of lymphoid tissues as well as velar length with respect to nasopharyngeal depth, and thus allow the speech pathologist, the orthodontist, and the otologist to assist the plastic surgeon in planning an appropriate and realistic treatment program for these patients.

What is the importance of mandibular movement to speech proficiency? (The instrumentation described by Gibbs and Messerman, elsewhere in this *Report*, easily could be applied to this question.) We are told that "speech is often affected by temporomandibular joint disturbances" and that the correction of occlusal aberrations such as overbites and open bites will "generally produce a marked improvement in the effective speech" (Balber et al., 1962). Yet our clinical experience with cases of temporomandibular joint ankylosis and various forms and degrees of malocclusion, as well as the impressive

review of this literature by Bloomer (1971), leave us with the strong impression that "compensation" decidedly is the rule, since the majority of these patients manage to function quite well. But what are the mechanisms of compensation in these patients? More important, what are the variables that will enable us to predict which patients will compensate and which will not compensate for a given condition?

#### CONCLUDING REMARKS

Our state of knowledge has not, as yet, come close to allowing us to justify such procedures as early maxillary orthopedics, primary bone grafting, rapid maxillary expansion, or tongue-thrust therapy on the grounds that they will lead to certain and lasting improvement in speech or arch form. There is little evidence that will allow definitive statements regarding the interaction of type and degree of cleft, type and timing of surgery, and resultant function in our cleft-palate patients. As we examine the many possibilities for collaborative efforts between dentists and speech pathologists/audiologists, let us constantly reexamine several general considerations that seem appropriate for joint research efforts. What is the applicability of our data and our measurement tools to infants and young children? Do our transducers interfere with or alter the function under study? Will our investigative approaches enable us to minimize or avoid repeated radiation to our patients? Above all, let us exercise a judicious and thoughtful selection of research questions. The fact that we possess the capacity for speech must not be construed as providing license to investigate every movement, muscle, and molecule presumed to play a role in speech production. There must be a careful ordering of priorities, not only because of the shrinking federal research dollar, but also because of the great number of valid and vital research issues that confront us.

#### ACKNOWLEDGMENT

This work was supported by Research Grant DE 02172 from the National Institute of Dental Research.

#### REFERENCES

- BALBER, G., CORET, F., LITOWITZ, R., ROSENTHAL, A., and SEITLIN, J., Dentofacial aspects of speech disturbances. Ch. 20 in N. M. Levin (Ed.), *Voice and Speech Disorders: Medical Aspects*. Springfield, Ill.: Charles C Thomas (1962).
- BALLARD, C. F., and BOND, E. K., Clinical observations on the correlation between variations of jaw form and variations of oro-facial behavior, including those for articulation. *Speech Pathol. Ther.*, 3, 55-62 (1960).
- BLOOMER, H. H., Speech defects associated with dental malocclusions and related abnormalities. Ch. 28 in L. Travis (Ed.), *Handbook of Speech Pathology and Audiology*. New York: Appleton (1971).
- CAMPOS-GIRAL, R., and COLE, R. M., A method for evaluating the degree of mesial movements of the lateral pharyngeal walls. *Cleft Pal. Bull.*, 13, 64-66 (1963).
- COLE, R. M., Cleft lip and palate: Progress and problems. *Chicago med. School Quart.*, 3, 129-136 (1966).

- COLE, R. M., Speech. *Proceedings of the Conference Patterns of Orofacial Growth and Development*. ASHA Reports Number 6. Washington, D.C.: American Speech and Hearing Association, 79-95 (March 1971).
- COLE, R. M., The speech pathologist in cases with orofacial deformities. *Schweiz.Mschr.-Zahnheilk.*, **80**, 418-435 (1970).
- ENGMAN, L. T., SPRIESTERSBACH, D. C., and MOLL, K. L., Cranial base angle and nasopharyngeal depth. *Cleft Pal. J.*, **2**, 32-39 (1965).
- FAWCUS, R., and BOYES, J., Dental problems in speech pathology. *Proc. roy. Soc. Med.*, **61**, 619-622 (1968).
- FLOWER, R. M., and LAWSON, LUCIE I., Neuromuscular dysfunction and the rehabilitation of children with coincident speech and orofacial problems. *Proceedings of the Conference Patterns of Orofacial Growth and Development*. ASHA Reports Number 6. Washington, D.C.: American Speech and Hearing Association, 48-57 (March 1971).
- FOSTER, T. D., and GREENE, M. C. L., Lateral speech defects and dental irregularities in cleft palate. *Brit. J. plast. Surg.*, **12**, 367-372 (1960).
- FROWINE, V. K., and MOSER, H., Relationship of dentition to speech. *J. Amer. dent. Ass.*, **31**, 1081-1090 (1944).
- GEORGIADIS, N. G., MLADICK, R. A., THORNE, F. L., and MASSENGILL, R., Preliminary evaluation of the island flap in cleft palate repair. *Cleft Pal. J.*, **6**, 488-494 (1969).
- GONZALEZ, J. B., and ARONSON, A. E., Palatal lift prosthesis for treatment of anatomic and neurologic palatopharyngeal insufficiency. *Cleft Pal. J.*, **7**, 91-104 (1970).
- GRABER, T. M., BZOCH, K. R., and AOBA, T., A functional study of the palatal and pharyngeal structures. *Angle Orthodont.*, **9**, 30-40 (1959).
- GROSSMAN, R., HATTIS, B., and RINGEL, R., Oral tactile experience. *Arch. oral Biol.*, **10**, 691-705 (1965).
- HAGERTY, R. F., HESS, D. A., and MYLIN, W. K., Velar motility, velopharyngeal closure, and speech proficiency in cartilage pharyngoplasty: The effect of age at surgery. *Cleft Pal. J.*, **5**, 317-326 (1968).
- HARDY, J. C., NETSELL, R., SCHWEIGER, J. W., and MORRIS, H. L., Management of velopharyngeal dysfunction in cerebral palsy. *J. Speech Hearing Dis.*, **34**, 123-136 (1969).
- HOCHBERG, I., and KABCENELL, J., Oral stereognosis in normal and cleft palate individuals. *Cleft Pal. J.*, **4**, 47-57 (1967).
- HOFFMAN, J. A., and HOFFMAN, R. L., Tongue-thrust and deglutition: Some anatomical, physiological, and neurological considerations. *J. Speech Hearing Dis.*, **30**, 105-120 (1965).
- HORTON, C. E., ADAMSON, J. E., and COOPER, R., The prevention of maxillary collapse in congenital lip and palate cases. *Cleft Pal. J.*, **1**, 25-31 (1964).
- JANN, GLADYS R., WARD, MARION M., and JANN, H. W., A longitudinal study of articulation and malocclusion. *J. Speech Hearing Dis.*, **29**, 424-435 (1964).
- KIMBALL, H. D., and MUYSKENS, J. H., Speech reconstruction after prosthesis. *J. Amer. dent. Ass. dent. Cosmos*, **24**, 1158-1168 (1937).
- KING, W. H., REID, P., and BELTING, C. M., The influence of extraction and replacement of teeth on hearing. *Pros. Dent.*, **23**, 148-153 (1970).
- LAWSON, W. ALAN, and BOND, E. K., Speech and its relation to dentistry: II. The influence of oral structures on speech. *Dent. Practit.*, **4**, 113-118 (1968).
- LUBIT, E. C., and LARSEN, R. E., The Lubit palatal exerciser: A preliminary report. *Cleft Pal. J.*, **6**, 120-133 (1969).
- LUBKER, J. F., SCHWEIGER, J. W., and MORRIS, H. L., Nasal airflow characteristics during speech in prosthetically managed cleft palate speakers. *J. Speech Hearing Res.*, **13**, 326-338 (1970).
- MARTONE, A. L., and BLACK, J. W., The phenomenon of function in complete denture prosthodontics. An approach to prosthodontics through speech science. *Pros. Dent.*, **12**, 409-419 (1962).
- MASSENGILL, R., QUINN, G. W., PICKRELL, K. L., and LEVINSON, C., Therapeutic exercise and velopharyngeal gap. *Cleft Pal. J.*, **5**, 44-47 (1968).
- MAZAHERI, M., and MILLARD, R. T., Changes in nasal resonance related to differences in location and dimension of speech bulbs. *Cleft Pal. J.*, **2**, 167-175 (1965).
- MAZAHERI, M., MILLARD, R. T., and ERICKSON, D. M., Cineradiographic comparison of normal to noncleft subjects with velopharyngeal inadequacy. *Cleft Pal. J.*, **1**, 199-209 (1964).
- MCGLONE, R. E., PROFFIT, W. R., and CHRISTIANSEN, R. L., Lingual pressures associated with alveolar consonants. *J. Speech Hearing Res.*, **10**, 606-615 (1967).

- MILLARD, R., BALBER, G., and PHILLIPS, B. W., A data collection system for cleft lip and palate: I. Surgical evaluation. *Cleft Pal. J.*, 4, 277-290 (1967).
- MOLLER, K. T., MARTIN, R. R., and CHRISTIANSEN, R. L., A technique for recording velar movement. *Cleft Pal. J.*, 8, 263-276 (1971).
- MYLIN, W. K., HAGERTY, R. F., and HESS, D. A., The pin-retained prosthesis in cleft palate orthopedics. *Cleft Pal. J.*, 5, 219-228 (1968).
- OSBORNE, G. S., PRUZANSKY, S., and KOEPP-BAKER, H., Upper cervical spine anomalies and osseous nasopharyngeal depth. *J. Speech Hearing Res.*, 14, 14-22 (1971).
- OWSLEY, J. Q., LAWSON, L. I., MILLER, E. R., HARVOLD, E. P., CHIERICI, G., and BLACKFIELD, H. M., Speech results from the high attached pharyngeal flap operation. *Cleft Pal. J.*, 7, 306-307 (1970).
- PROFFIT, W. R., FOGLE, J. L., HEITLINGER, L. W., CHRISTIANSEN, R. L., and MCCLONE, R. E., Dynamic calibration of lingual pressure transducers. *J. appl. Physiol.*, 21, 1417-1420 (1966).
- PRUZANSKY, S., Informal address. In R. M. Cole (Ed.), *Early Treatment of Cleft Lip and Palate: Proceedings of the Second International Symposium*. Chicago, Ill.: Northwestern Univ. Cleft Palate Institute, 163-169 (1970).
- PRUZANSKY, S., and ADUSS, H., Prevalence of arch collapse and malocclusion in complete unilateral cleft lip and palate. *Europ. orthodont. Soc. Rep. Congr.*, 43, 365-382 (1967).
- RATHBONE, J. S., and SNIDECOR, J. C., Appraisal of speech defects in dental anomalies with reference to speech improvement. *Angle Orthodont.*, 29, 54-59 (1959).
- ROSEN, M. S., and BZOCH, K. R., The prosthetic speech appliance in rehabilitation of patients with cleft palate. *J. Amer. dent. Ass.*, 57, 203-210 (1958).
- SHELTON, R. L., LINDQUIST, A. F., CHISUM, L. ARNDT, W. B., YOUNGSTROM, K. A., and STICK, S. L., Effect of prosthetic speech bulb reduction on articulation. *Cleft Pal. J.*, 5, 195-204 (1968).
- SHELTON, R. L., LINDQUIST, A. F., KNOX, A. W., WRIGHT, V. L., ARNDT, W. B., and YOUNGSTROM, K. A., The relationship between pharyngeal wall movements and exchangeable speech appliance sections. *Cleft Pal. J.*, 8, 145-158 (1971).
- SLOAN, R. F., RICKETTS, R. M., BENCH, R. W., HAHN, ELISE, WESTOVER, J., and BRUMMETT, S., The application of cephalometrics to cinefluorography. *Angle Orthodont.*, 34, 132-141 (1964).
- SNIDECOR, J. C., and KAIRE, A. K., A speech corrective prosthesis for anterior "open bite" malocclusion and its effect on two postdental fricative sounds. *Pros. Dent.*, 15, 779-784 (1965).
- STARR, C. D., MESKIN, L. H., SHAPIRO, B. L., and WEIST, KAREN, Nasality and cleft uvula. *Cleft Pal. J.*, 8, 189-195 (1971).
- STOCKLI, P. W., Application of a quantitative method for arch form evaluation in complete unilateral cleft lip and palate. *Cleft Pal. J.*, 8, 322-341 (1971).
- SUBTELNY, JOANNE, McCORMACK, R. M., CURTIN, J. W., SUBTELNY, J. D., and MUSGRAVE, K. S., Speech, intraoral air pressure, nasal airflow—before and after pharyngeal flap surgery. *Cleft Pal. J.*, 7, 68-90 (1970).
- SUBTELNY, J. D., McCORMACK, R. M., SUBTELNY, JOANNE, WORTH, J. H., CRAMER, L. M., RUNYON, J. C., and ROSENBLUM, R. M., Synchronous recording of speech with associated physiological and pressure-flow dynamics: Instrumentation and procedures. *Cleft Pal. J.*, 5, 93-116 (1968).
- SUBTELNY, JOANNE, MESTRE, J. C., and SUBTELNY, J. D., Comparative study of normal and defective articulation of /s/ as related to malocclusion and deglutition. *J. Speech Hearing Dis.*, 29, 269-285 (1964).
- SUBTELNY, J. D., PRUZANSKY, S., and SUBTELNY, JOANNE, The application of roentgenography in the study of speech. In L. Kaiser (Ed.), *Manual of Phonetics*. Amsterdam: North Holland, 167-179 (1957).
- SUBTELNY, JOANNE, SAKUDA, M., and SUBTELNY, J. D., Prosthetic treatment for palatopharyngeal incompetence: Research and clinical implications. *Cleft Pal. J.*, 3, 130-158 (1966).
- SUBTELNY, J. D., and SUBTELNY, JOANNE, Malocclusion, speech, and deglutition. *Amer. J. Orthodont.*, 48, 685-697 (1962).
- SUBTELNY, JOANNE, WORTH, J. H., and SAKUDA, M., Intraoral pressure and rate of flow during speech. *J. Speech Hearing Res.*, 9, 499-518 (1966).
- WARD, MARION, MALONE, HELEN, JANN, GLADYS, and JANN, H. W., Articulation variations

associated with visceral swallowing and malocclusion. *J. Speech Hearing Dis.*, **26**, 334-341 (1961).

WARREN, D. W., Restorative treatment of the dentofacial complex. *Proceedings of the Workshop Speech and the Dentofacial Complex: The State of the Art. ASHA Reports Number 5*. Washington, D.C.: American Speech and Hearing Association, 132-145 (October 1970).

WARREN, D. W., WOOD, M. T., and BRADLEY, DORIS, Respiratory volumes in normal and cleft palate speech. *Cleft Pal. J.*, **6**, 449-460 (1969).

WILDMAN, A. J., FLETCHER, S. G., and COX, BARBARA, Patterns of deglutition. *Angle Orthodont.*, **34**, 271-291 (1964).



## SUMMARY REMARKS

D. C. SPRIESTERSBACH

*University of Iowa, Iowa City, Iowa*

We now come to the end of the second conference designed to bring dentists, speech pathologists, and audiologists together to explore further the possible common bonds that may profitably exist between us. I am not going to take time to review the substantive material, but I should like to make several observations which may place these proceedings in perspective.

It is evident that this conference created various degrees of tension. Comments were made that the papers were too elementary, too inconsequential, too abstract, too thin, too this, too that. These reactions are typical from groups with different skills, different interests, different knowledges who try to work together. But we can never work together unless we are willing to take the time to develop the common understandings required for common efforts. To do so means that some of us have to be willing to endure the review of familiar material or plow through unfamiliar material some of the time. However, this problem of establishing effective communication and mutual respect should not be new to any of us, for it exists between the teachers, researchers, and clinicians within our respective professions as well as between our professions. So I hope we will continue to be willing to begin where we are and to take one step at a time toward effective interprofessional interaction.

During this conference I heard the expression "In my/his hands." This phrase has interested me for a long time. It is used sincerely, but it is rarely helpful. It allows us a comfortable way to escape the difficult and disturbing search for the question to be answered, the clear statement of the appropriate hypotheses to be tested, the specification of the criteria to be used in the evaluation of our observations. I refuse to accept the notion that there is a mystique about some of the work that we do that forever defies systematic observation and the accumulation of data from which we can make generalizations.

I was pleased to hear repeated mention of many of the established requirements of scientific inquiry: the need to establish the critical parameters of population to be studied; the care with which cause and effect relationships should be proposed on the basis of correlated phenomena; the need for the operational definition of terms; the need to be aware of the uniqueness as well as the similarities between individuals in given populations; the awareness of

the possible interactions between subsystems; the need to identify and state assumptions; the need for the establishment of base lines of data on normal function before attempting to evaluate and explain the functions of abnormal and pathological systems; and so on. We are becoming more sophisticated in our approach to the problems we must solve, but we still have far to go.

One of my mentors, Wendell Johnson, used to say that "You can talk until you are 80 and you will only say what you know." Many of us, particularly those of us who graduated from training programs more than five years ago, have had poor training for understanding the complexities of the clinical problems and the research methodologies as they are understood by some today. Many of us have taught or are teaching at superficial levels because we were taught by teachers who also had a superficial, second-hand understanding of the material. But there is no need to apologize or to be defensive—just a need to be aware of our shortcomings. And I am convinced that even those of us who are freshly trained will rarely find that they can function with impunity as self-sufficient teachers, researchers, or clinicians in this field. All of us have got to learn to work together. It's going to take time. It's going to be difficult and frustrating. We are going to lose some of our freedom, both personally and professionally. But we have no other choice.

I believe we have found some areas of overlap of interest and concern during this conference. Some interesting and exciting research ideas have emerged. I suspect some of our training material will be changed. If I am correct, this conference will have been worthwhile.

## CONFERENCE ATTENDANTS

- Frank Andrews, M.A.*, University of Wisconsin.  
*James L. Aten, Ph.D.*, University of Denver.  
*Ysaye Barnwell, M.Ed.*, Howard University.  
*Asa J. Berlin, Ph.D.*, Pennsylvania State University.  
*Helen L. Blain, D.D.S.*, University of Missouri School of Dentistry.  
*Larry Blauhvietz, M.A.*, University of Illinois.  
\**H. Harlan Bloomer, Ph.D.*, University of Michigan.  
*Donald F. Bowers, D.D.S.*, Medical College of Georgia School of Dentistry.  
\**Gerald J. Canter, Ph.D.*, Northwestern University.  
*Ann L. Carey, Ph.D.*, Southern Illinois University.  
\**Richard M. Cole, Ph.D.*, St. Louis University School of Dentistry.  
*Donald T. Counihan, Ph.D.*, University of Oklahoma Medical Center.  
*Zilpha B. Crouch, M.A.*, University of Kansas Medical Center.  
\**Frederic K. W. Curry, Ph.D.*, Michael Reese Hospital, Chicago.  
*Billie Daniel, M.A.*, University of Wisconsin.  
*Alexander Davidovitch, D.M.D.*, University of Pennsylvania School of Dentistry.  
*Leo V. Deal, Ph.D.*, Michigan State University.  
*Armand Dumas, D.D.S.*, Georgetown University School of Dentistry.  
*Samuel R. Faircloth, Ph.D.*, Florida State University.  
*Mervyn L. Falk, Ph.D.*, Wayne State University.  
*James E. Fricke, Ph.D.*, American Speech and Hearing Association.  
*Donald J. Fucci, Ph.D.*, Ohio University.  
*Tanya Gallagher, M.A.*, University of Illinois.  
\**Charles H. Gibbs, Ph.D.*, Case Western Reserve University.  
*Ronald Goldman, Ph.D.*, Bill Wilkerson Hearing and Speech Center, Nashville.  
*Lloyd A. Green, D.D.S.*, Medical College of Virginia.  
*Zora Griffo, Ph.D.*, National Institute of Dental Research, U.S. Public Health Service.  
*Marvin L. Hanson, Ph.D.*, University of Utah.  
*Kenneth Hisaoka, Ph.D.*, National Institute of Dental Research, U.S. Public Health Service.  
\**Thomas J. Hixon, Ph.D.*, University of Wisconsin.  
*Lisa Holstead, M.A.*, University of Illinois.  
*Kenneth P. Hopkins, D.D.S.*, University of Tennessee College of Dentistry.  
*Dee Jay Hubbard, Ph.D.*, University of Kansas.

---

\* Participant presenting a paper.

*Maurice Joselson, Ph.D.*, Wellesley, Massachusetts.  
*Krisham Kapur, D.D.S.*, Harvard University.  
 \**Frank R. Kleffner, Ph.D.*, Central Institute for the Deaf.  
*Joseph A. Kools, Ph.D.*, University of Georgia.  
*Robert B. Mahaffey, Ph.D.*, University of Southern Mississippi.  
*Tom Marshall, M.A.*, University of Wisconsin.  
*Marion D. Meyerson, M.A.*, University of Illinois.  
*Robert E. Moyers, D.D.S., Ph.D.*, Center for Human Growth and Development, University of Michigan.  
 \**Frederick M. Parkins, D.D.S.*, University of Iowa College of Dentistry.  
*Judith Pratt, M.A.*, University of Illinois.  
*Elisha R. Richardson, D.D.S.*, Meharry Medical College.  
*Robert L. Ringel, Ph.D.*, Purdue University.  
*E. Gene Ritter, Ph.D.*, Indiana University.  
*Sara E. Runyan, M.A.*, University of Kentucky Medical Center.  
*Robert Saporto, D.D.S.*, New York University.  
*John H. Saxman, Ph.D.*, University of Wisconsin.  
*Robert P. Scapino, D.D.S.*, University of Illinois College of Dentistry.  
*Robert Schallhorn, D.D.S.*, University of Colorado School of Dentistry.  
*Martin F. Schwartz, Ph.D.*, Temple University.  
*Frederick R. Shiere, D.D.S.*, Tufts University School of Dental Medicine.  
 \**Sidney I. Silverman, D.D.S.*, New York University College of Dentistry.  
*Gary Smiley, D.D.S.*, University of North Carolina School of Dentistry.  
*Robert M. Sommerfeld, D.D.S.*, Loyola University.  
 \**Duane C. Priestersbach, Ph.D.*, University of Iowa.  
*Ray H. Steinacher, D.D.S.*, University of Nebraska School of Dentistry.  
*Arlene Tarlow, M.A.*, University of Wisconsin.  
*J. Bruce Tomblin, Ph.D.*, Syracuse University.  
*Rolland J. Van Hattum, Ph.D.*, State University College at Buffalo.  
*Donald W. Warren, D.D.S., Ph.D.*, University of North Carolina School of Dentistry.  
*Bernd Weinberg, Ph.D.*, Indiana University Medical Center.  
*Robert T. Wertz, Ph.D.*, University of Colorado.  
*Nann A. Wickwire, D.D.S.*, University of Kentucky College of Dentistry.

