

भारत की राष्ट्रीय भवन निर्माण संहिता 2016 खण्ड 2

NATIONAL BUILDING CODE OF INDIA 2016 VOLUME 2

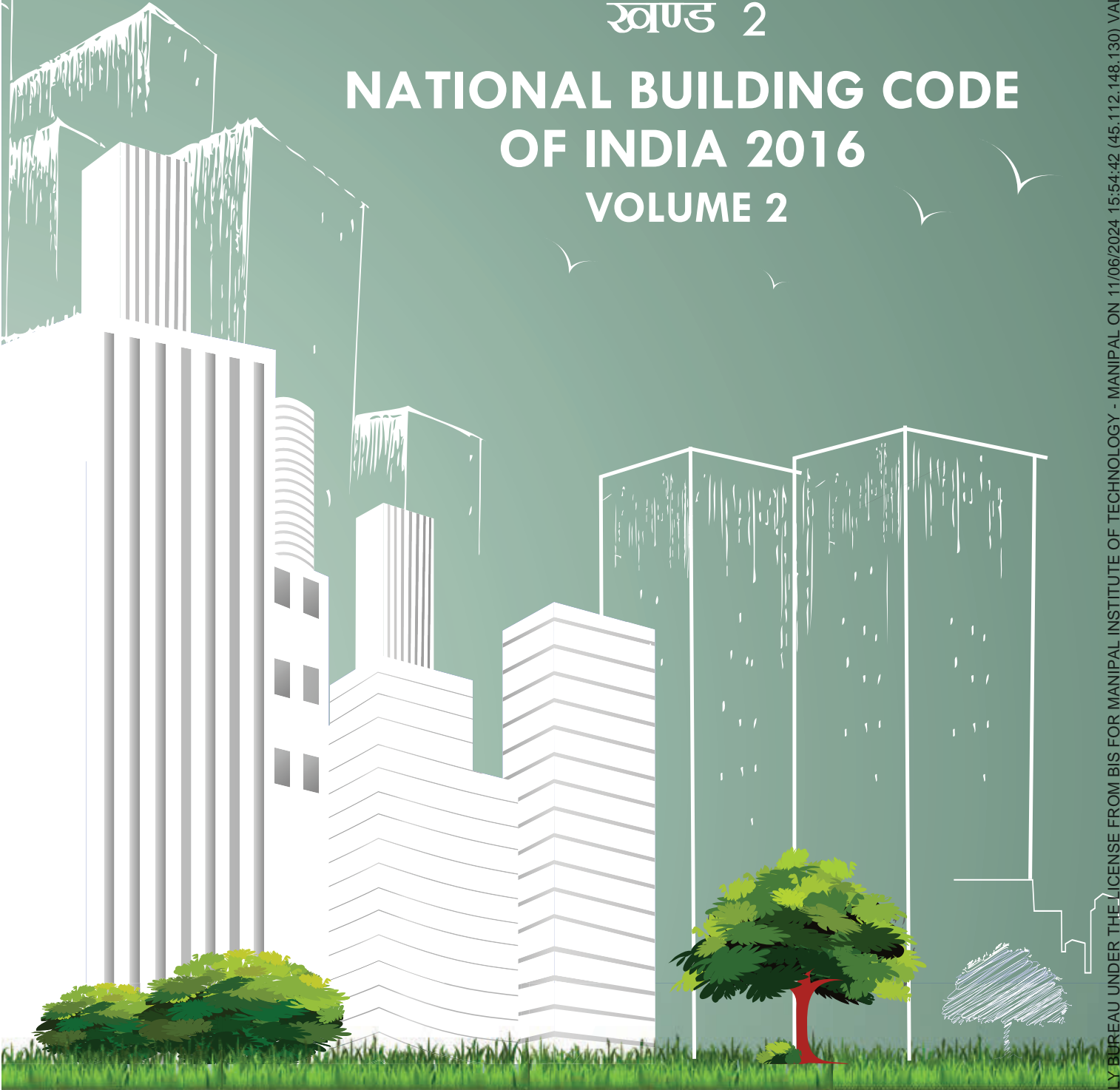

भारतीय मानक ब्यूरो
BUREAU OF INDIAN STANDARDS

भारत की राष्ट्रीय
भवन निर्माण संहिता 2016
खण्ड 2

**NATIONAL BUILDING CODE
OF INDIA 2016
VOLUME 2**



भारतीय मानक ब्यूरो
BUREAU OF INDIAN STANDARDS

SP 7 : 2016

FIRST PUBLISHED 1970

FIRST REVISION 1983

SECOND REVISION 2005

THIRD REVISION 2016

© BUREAU OF INDIAN STANDARDS

ICS 01.120; 91.040.01

PRICE ₹ 13,760
(Vol. 1 & 2)

PUBLISHED BY BUREAU OF INDIAN STANDARDS, MANAK BHAVAN, 9 BAHADUR SHAH ZAFAR MARG, NEW DELHI 110002; TYPESET AT SUNSHINE GRAPHICS, 263, TELIWARA, SHAHDARA, DELHI 110032; PRINTED AT J. J. OFFSET PRINTERS, A-24, SECTOR 68, NOIDA, GAUTAM BUDH NAGAR, UTTAR PRADESH (INDIA).

CONTENTS

Volume 1

FOREWORD	...	(v)
COMMITTEE COMPOSITION	...	(ix)
IMPORTANT EXPLANATORY NOTE FOR USERS OF THE CODE	...	(xxx)
INFORMATION FOR THE USERS ABOUT AVAILABILITY OF THE CODE IN GROUPS	...	(xxxi)
		<i>Total Pages</i>
PART 0 INTEGRATED APPROACH — PREREQUISITE FOR APPLYING PROVISIONS OF THE CODE	...	12
PART 1 DEFINITIONS	...	28
PART 2 ADMINISTRATION	...	32
PART 3 DEVELOPMENT CONTROL RULES AND GENERAL BUILDING REQUIREMENTS	...	150
PART 4 FIRE AND LIFE SAFETY	...	116
PART 5 BUILDING MATERIALS	...	46
PART 6 STRUCTURAL DESIGN		
Section 1 Loads, Forces and Effects	...	134
Section 2 Soils and Foundations	...	60
Section 3 Timber and Bamboo		
3A Timber	...	56
3B Bamboo	...	30
Section 4 Masonry	...	86
Section 5 Concrete		
5A Plain and Reinforced Concrete	...	118
5B Prestressed Concrete	...	52
Section 6 Steel	...	138
Section 7 Prefabrication, Systems Building and Mixed/Composite Construction		
7A Prefabricated Concrete	...	42
7B Systems Building and Mixed/Composite Construction	...	12
Section 8 Glass and Glazing	...	80

Volume 2

IMPORTANT EXPLANATORY NOTE FOR USERS OF THE CODE	...	(iv)
INFORMATION FOR THE USERS ABOUT AVAILABILITY OF THE CODE IN GROUPS	...	(v)
		<i>Total Pages</i>
PART 7 CONSTRUCTION MANAGEMENT, PRACTICES AND SAFETY	...	76
PART 8 BUILDING SERVICES		
Section 1 Lighting and Natural Ventilation	...	56
Section 2 Electrical and Allied Installations	...	172
Section 3 Air Conditioning, Heating and Mechanical Ventilation	...	86
Section 4 Acoustics, Sound Insulation and Noise Control	...	46
Section 5 Installation of Lifts, Escalators and Moving Walks		
5A Lifts	...	96
5B Escalators and Moving Walks	...	44
Section 6 Information and Communication Enabled Installations	...	28
PART 9 PLUMBING SERVICES (INCLUDING SOLID WASTE MANAGEMENT)		
Section 1 Water Supply	...	44
Section 2 Drainage and Sanitation	...	82
Section 3 Solid Waste Management	...	16
Section 4 Gas Supply	...	18
PART 10 LANDSCAPE DEVELOPMENT, SIGNS AND OUTDOOR DISPLAY STRUCTURES		
Section 1 Landscape Planning, Design and Development	...	34
Section 2 Signs and Outdoor Display Structures	...	24
PART 11 APPROACH TO SUSTAINABILITY	...	98
PART 12 ASSET AND FACILITY MANAGEMENT	...	98

Important Explanatory Note for Users of the Code

In any Part/Section of this Code, where reference is made to ‘good practice’ in relation to design, constructional procedures or other related information, and where reference is made to ‘accepted standard’ in relation to material specification, testing, or other related information, the Indian Standards listed at the end of the Part/Section shall be used as a guide to the interpretation.

At the time of publication, the editions indicated in the standards were valid. All standards are subject to revision and parties to agreements based on any Part/Section are encouraged to investigate the possibility of applying the most recent editions of the standards.

In the list of standards given at the end of a Part/Section, the number appearing within parentheses in the first column indicates the number of the reference of the standard in the Part/Section. For example:

- a) Good practice [7(2)] refers to the Indian Standard given at serial number (2) of the list of standards given at the end of Part 7, that is, IS 16416 : 2016 ‘Construction project management: Project formulation and appraisal — Guidelines’.
- b) Good practice [8-1(6)] refers to the Indian Standard given at serial number (6) of the list of standards given at the end of Section 1 of Part 8, that is, IS 3362 : 1977 ‘Code of practice for natural ventilation of residential buildings (*first revision*)’.
- c) Good practice [8-3(16)] refers to the Indian Standard given at serial number (16) of the list of standards given at the end of Section 3 of Part 8, that is, IS 4831 : 1968 ‘Recommendation on units and symbols for refrigeration’.
- d) Accepted standard [8-5A(6)] refers to the Indian Standard given at serial number (6) of the list of standards given at the end of Subsection 5A of Part 8, that is, IS 14665 (Part 3/Sec 1 and 2) : 2000 ‘Electric traction lifts: Part 3 Safety rules, Section 1 Passenger and goods lifts, Section 2 Service lifts’.
- e) Accepted standards [8-6(2)] refers to the Indian Standards given at serial number (2) of the list of standards given at the end of Section 6 of Part 8, that is, IS 9537 (Part 3) : 1983 ‘Specification for conduits for electrical installations: Part 3 Rigid plain conduits for insulating materials’ and IS 3419 : 1989 ‘Specification for fittings for rigid non-metallic conduits (*second revision*)’.
- f) Accepted standard [9-1(1)] refers to the Indian Standard given at serial number (1) of the list of standards given at the end of Section 1 of Part 9, that is, IS 10446 : 1983 ‘Glossary of terms relating to water supply and sanitation’.

INFORMATION FOR THE USERS ABOUT AVAILABILITY OF THE CODE IN GROUPS

For the convenience of the users, the National Building Code of India 2016 is available as a comprehensive volume as well as in the following five groups, each incorporating the related Parts/Sections dealing with particular area of building activity:

Group 1	For Development/ Building Planning and Related Aspects	Part 0	Integrated Approach — Prerequisite for Applying Provisions of the Code
		Part 1	Definitions
		Part 2	Administration
		Part 3	Development Control Rules and General Building Requirements
		Part 4	Fire and Life Safety
		Part 5	Building Materials
		Part 10	Landscape Development, Signs And Outdoor Display Structures
		Section 1	Landscape Planning, Design and Development
		Section 2	Signs and Outdoor Display Structures
		Part 11	Approach to Sustainability
		Group 2	For Structural Design and Related Aspects
Part 6	Structural Design		
Section 1	Loads, Forces and Effects		
Section 2	Soils and Foundations		
Section 3	Timber and Bamboo		
3A	Timber		
3B	Bamboo		
Section 4	Masonry		
Section 5	Concrete		
5A	Plain and Reinforced Concrete		
5B	Prestressed Concrete		
Section 6	Steel		
Section 7	Prefabrication, Systems Building and Mixed/ Composite Construction		
7A	Prefabricated Concrete		
7B	Systems Building and Mixed/ Composite Construction		
Section 8	Glass and Glazing		
Part 11	Approach to Sustainability		
Group 3	For Aspects Relating to Construction, and Asset/ Facility Management	Part 0	Integrated Approach — Prerequisite for Applying Provisions of the Code
		Part 7	Construction Management, Practices and Safety
		Part 11	Approach to Sustainability
		Part 12	Asset and Facility Management
Group 4	For Aspects Relating to Building Services	Part 0	Integrated Approach — Prerequisite for Applying Provisions of the Code
		Part 8	Building Services
		Section 1	Lighting and Natural Ventilation
		Section 2	Electrical and Allied Installations
		Section 3	Air Conditioning, Heating and Mechanical Ventilation
		Section 4	Acoustics, Sound Insulation and Noise Control
		Section 5	Installation of Lifts, Escalators and Moving Walks
		5A	Lifts
		5B	Escalators and Moving Walks
		Section 6	Information and Communication Enabled Installations
		Part 11	Approach to Sustainability
Group 5	For Aspects Relating to Plumbing Services and Solid Waste Management	Part 0	Integrated Approach — Prerequisite for Applying Provisions of the Code
		Part 9	Plumbing Services (including Solid Waste Management)
		Section 1	Water Supply
		Section 2	Drainage and Sanitation
		Section 3	Solid Waste Management
		Section 4	Gas Supply
		Part 11	Approach to Sustainability

The information contained in different groups will serve the concerned professionals dealing with the respective areas. However, it is advisable that professionals essentially dealing with any of the above groups should also refer the other groups.

NATIONAL BUILDING CODE OF INDIA

PART 7 CONSTRUCTION MANAGEMENT, PRACTICES AND SAFETY

BUREAU OF INDIAN STANDARDS

CONTENTS

FOREWORD	... 3
1 SCOPE	... 7
2 TERMINOLOGY	... 7
3 GENERAL	... 7
SECTION 1 CONSTRUCTION MANAGEMENT	
4 CONSTRUCTION PROJECT MANAGEMENT	... 8
SECTION 2 CONSTRUCTION PLANNING AND SITE MANAGEMENT	
5 PLANNING ASPECTS	... 17
SECTION 3 CONSTRUCTION PRACTICES	
6 CONSTRUCTION CONTROL AND PRACTICES	... 19
7 TEMPORARY WORKS	... 21
8 STORAGE, STACKING AND HANDLING PRACTICES	... 23
SECTION 4 SAFETY IN CONSTRUCTION	
9 SAFETY IN CONSTRUCTION OF ELEMENTS OF A BUILDING	... 34
10 SAFETY IN DEMOLITION OF BUILDINGS	... 52
SECTION 5 REPAIRS, RETROFITTING AND STRENGTHENING OF BUILDINGS	
11 MAINTENANCE MANAGEMENT	... 57
12 PREVENTION OF CRACKS	... 57
13 REPAIRS AND SEISMIC STRENGTHENING OF BUILDINGS	... 58
SECTION 6 HABITAT AND WELFARE REQUIREMENTS FOR WORKERS	
14 HABITAT AND OTHER WELFARE REQUIREMENTS FOR CONSTRUCTION WORKERS	... 59
ANNEX A CHECK LIST FOR STACKING AND STORAGE OF MATERIALS	... 63
LIST OF STANDARDS	... 64

FOREWORD

This Code (Part 7) covers construction project management; construction planning, site management and building construction practices; storage, stacking and handling of materials; and safety of personnel during construction operations for all elements of a building and demolition of buildings; and habitat and welfare requirements for workers. It also covers guidelines relating to repairs, retrofitting and strengthening of buildings.

The principles enunciated in the various sections of this Part are to be ultimately utilized and implemented in the physical construction of the buildings with the required infrastructure. This would require sound construction practices and efficient management thereof in order to ensure that the implementation of the project is carried out within the estimated cost and planned period to the required quality standards and in a safe and sustainable manner. Workers in large number, both skilled and unskilled, are engaged in the innumerable construction works. Due to increased tempo of such a building activity and large scale mechanization, hazards of accidents could increase considerably. It is, therefore, imperative that adequate safety rules are laid down for every phase of construction work. It is also important to give due cognizance to habitat and welfare requirements of workers at construction site. This Part also deals with these aspects.

Planning the various construction operations before hand and making adequate arrangements for procurement and storage of materials, and the machinery to get work done is as important as carrying out these construction operations in accordance with good practice. Lack of planning or defective planning may result in avoidable delay in the completion of work and consequently increased hazards from the point of view of fire, health and structural soundness. This Part covers provisions in this regard.

A construction project is an endeavour undertaken by a project team on behalf of owner/client to create a built facility suited to the defined functional objectives. From inception to commissioning, the project goes through various distinct stages leading to progressive achievement of project objectives. Each stage involves specific inputs, processes (both technical and managerial) and deliverables. Typically, the life cycle of a project from commencement to completion involves the following stages:

- a) *Project formulation and appraisal* — Inception, feasibility and strategic planning;
- b) *Project development* — Project brief development, planning and design, finalization of proposals, procurement strategy, construction documentation including tender drawings, working drawings, specifications, cost estimates, bills of quantities, procurement documents;
- c) *Planning for construction* — Sequencing of project components, planning tools, resource planning and time cost trade off;
- d) *Tender action* — Open competitive bidding/pre-qualification of agencies, issue of tender documents, evaluation of bids, negotiation if required and award of work;
- e) *Construction* — Execution, monitoring, control, work acceptance; and
- f) *Commissioning and handing over* — Contractual closeout, financial closeout, defect liability commencement, facility handing over.

The distinct features of a construction project include the temporary nature of the organizations involved, the evolutionary process of project deliverables during project development stages and the unique output of the built facility. As a result of these features, unless there is efficient and effective project management, a construction project is faced with challenges of uncertainties leading to time over-runs, cost over-runs, changes in project parameters, loss of quality and inability to meet the functional objectives. While technical soundness of a proposal is an important aspect of a construction project, the management aspects, which involve techno-legal, financial and other issues, have also a significant role in the success of a project. Therefore, management functions and technical processes in a construction project need to be integrated towards achieving project objectives. Top management commitment plays an important role in harmoniously achieving these project objectives. In some of the public sector projects, it may be necessary to share relevant information with public at large through appropriate

means. The overall management of a building construction project is very important to ensure that the objectives of such a project are achieved through scope management, procurement management, time management, cost management, quality management, risk management, communication management, human resources management, safety, health and environment management and integration management. This Part, therefore, gives guidelines on these areas.

The first version of this Part was formulated in 1970, which was subsequently revised in 1983 and 2005. In the first revision, information regarding handling operations that is unloading, stacking, lifting, loading and conveying of building materials, was also given along with the storage practices. Additional information regarding the use of ladders; safety requirements for floor and wall openings, railings and toe boards; piling and other deep foundations; constructions involving use of hot bituminous materials; and erection of structural steel work and concrete framed structures, etc, were included.

In the second revision, the Section 1 'Construction Practices' of this Part, had been revamped to include the planning and management aspects. Further, provisions on construction using bamboo were also incorporated. The other important modifications incorporated in the second revision included comprehensive updating of the provisions with regard to stacking and storage of building materials and components, which were comprehensively covered in line with the revised IS 4082 : 1996 'Recommendations on stacking and storage of construction materials and components at site (*second revision*)'; addition of provisions of safety requirements of hoists/lifts for worker during construction; incorporation of aspects like preventive measures such as falling material hazards prevention, fall prevention, disposal of debris, fire protection, etc, with regard to safety at work site; addition of provisions regarding safety management at work sites; addition of a new section on 'Maintenance management, repairs, retrofitting and strengthening of buildings', covering aspects like maintenance management, prevention of cracks, and repairs and seismic strengthening of buildings; and updating of safety provisions with respect to demolition of buildings.

As a result of experience gained in implementation of 2005 version of this Part and feedback received as well as in view of formulation of new standards in the field of construction project management and construction practices and revision of some existing standards, including those on safety, a need to revise this Part was felt. This revision has, therefore, been prepared to take care of these aspects. This Part has been divided into six sections as follows, under which all technical provisions relating to their subject areas, have been given:

- Section 1 Construction Management
- Section 2 Construction Planning and Site Management
- Section 3 Construction Practices
- Section 4 Safety in Construction
- Section 5 Repairs, Retrofitting and Strengthening of Buildings
- Section 6 Habitat and Welfare Requirements for Workers

The significant changes incorporated in this revision include:

- a) This Part has been divided into six Sections under which the provisions have been rearranged in a logical sequence;
- b) Provisions on construction project management have been detailed which also now includes project formulation and appraisal.
- c) Safety provisions with respect to scaffolding, piling and other deep foundations, blasting and related drilling operations, and construction involving use of hot bituminous materials have been updated;
- d) A new clause on habitat and other welfare requirements for construction workers has been introduced;
- e) A new clause on urban/city roads planning and construction, has been added;
- f) A new clause on temporary works has been included;
- g) Provisions on construction using bamboo has been shifted to Part 6 'Structural Design, Section 3B Bamboo, and a reference to the same has been given in this Part;
- h) Provisions on maintenance management has been shifted to Part 12 'Asset and Facility Management' of the Code and a reference to the same has been given in this Part; and
- j) References to all the concerned Indian Standards have been updated.

Users are encouraged to employ suitable construction management software as an aid to implement provisions of

this Code. The guidelines may be applicable in general to all construction projects. However, for smaller projects, the applicability of various provisions may be decided appropriately by the parties concerned.

Provisions on sustainable building construction practices are covered in Part 11 ‘Approach to Sustainability’ of the Code.

The information contained in this Part is largely based on the following Indian Standards and Special Publications:

IS 3696	Safety code for scaffolds and ladders:
(Part 1) : 1987	Scaffolds
(Part 2) : 1991	Ladders
IS 3764 : 1992	Code of practice for excavation work (<i>first revision</i>)
IS 4082 : 1996	Recommendations on stacking and storage of construction materials and components at site (<i>second revision</i>)
IS 4130 : 1991	Safety code for demolition of buildings (<i>second revision</i>)
IS 4912 : 1978	Safety requirements for floor and wall openings, railing and toe boards (<i>first revision</i>)
IS 5121 : 2013	Code of safety for piling and other deep foundations (<i>first revision</i>)
IS 5916 : 2013	Safety code for construction involving use of hot bituminous materials (<i>first revision</i>)
IS 7205 : 1974	Safety code for erection of structural steel work
IS 7969 : 1975	Safety code for handling and storage of building materials
IS 8989 : 1978	Safety code for erection of concrete framed structures
IS 13415 : 1992	Safety code for protective barrier in and around buildings
IS 13416	Recommendations for preventive measures against hazards at work places:
(Part 1) : 1992	Falling material hazards prevention
(Part 2) : 1992	Fall prevention
(Part 3) : 1994	Disposal of debris
(Part 4) : 1994	Timber structures
(Part 5) : 1994	Fire protection
IS 13430 : 1992	Code of practice for safety during additional construction and alteration to existing buildings
IS 15883 (Part 1) : 2009	Guidelines for construction project management: Part 1 General
IS 16601 : 2016	Guidelines for habitat and welfare requirements for construction workers

A reference to SP 62 : 1992 ‘Handbook on building construction practices (excluding electrical works)’ and SP 70 : 2001 ‘Handbook on construction safety practices’, may also be made.

All standards, whether given herein above or cross-referred to in the main text of this Part, are subject to revision. The parties to agreement based on this Part are encouraged to investigate the possibility of applying the most recent editions of the standards.

For the purpose of deciding whether a particular requirement of this Code is complied with, the final value, observed or calculated, expressing the result of a test or analysis, shall be rounded off in accordance with IS 2 : 1960 ‘Rules for rounding off numerical values (*revised*)’. The number of significant places retained in the rounded off value should be the same as that of the specified value in this Part.

NATIONAL BUILDING CODE OF INDIA

PART 7 CONSTRUCTION MANAGEMENT, PRACTICES AND SAFETY

1 SCOPE

1.1 This Code (Part 7) covers construction project management; construction planning, site management and building construction practices; storage, stacking and handling of materials; and safety of personnel during construction operations for all elements of a building and demolition of buildings; and habitat and welfare requirements for workers. It also covers guidelines relating to repairs, retrofitting and strengthening of buildings.

1.2 The provisions in respect of sustainable building construction practices are covered in Part 11 'Approach to Sustainability' of the Code which shall be used in conjunction with this Part.

1.3 Provisions relating to maintenance management are covered in Part 12 'Asset and Facility Management' of the Code which has been referred to in this Part.

2 TERMINOLOGY

For the purpose of this Part, the following definitions shall apply, and for other terms those given in the accepted standards [7(1)] shall apply.

2.1 Authority Having Jurisdiction

The authority which has been created by a statute and which for the purpose of administering the Code/Part, may authorize a committee or an official to act on its behalf; hereinafter called the 'Authority'.

2.2 Definitions Relating to Safety in Construction

2.2.1 Construction Equipment — All equipment, machinery, tools and temporary retaining structures and working platforms, that is, tools, derricks, staging, scaffolds, runways, ladders and all material, handling equipment including safety devices.

2.2.2 Floor Hole — An opening measuring less than 300 mm but more than 25 mm in its least dimension, in any floor, platform, pavement, or yard, through which materials but not persons may fall; such as, a belt hole, pipe opening or slot opening.

2.2.3 Floor Opening — An opening measuring 300 mm or more in its least dimension, in any floor, platform, pavement or yard through which person may fall; such as hatch way, stair or ladder opening, pit or large manhole.

2.2.4 Guard Railing — A barrier erected along exposed edges of an open side floor opening, wall opening,

ramp, platform, or catwalk or balcony, etc, to prevent fall of persons.

2.2.5 Materials Handling Hoists — A platform, bucket or similar enclosure exclusively meant for the lifting or lowering of construction material, the hoists being operated from a point outside the conveyance.

2.2.6 Pile Rig — The complete pile driving equipment comprising piling frame, leader, hammer, extractor winch and power unit. Complete pile driving rig may be mounted on rafts or pontoon or rails. Pile rig may also be a mobile unit mounted on trailers or trucks, or a special full revolving rig for raking piles.

2.2.7 Platform — A working space for persons, elevated above the surrounding floor or ground, such as balcony or platform for the operation of machinery and equipment.

2.2.8 Scaffold — A temporary structure consisting of standards, putlogs, ledgers, generally of bamboo, *Ballies*, timber or metal to provide a working platform for workers and materials in the course of construction, maintenance, repairs and demolition, and also to support or allow hoisting and lowering of workers, their tools and materials.

2.2.9 Toe Board — A vertical barrier erected along exposed edge of a floor opening, wall opening, platform, catwalk or ramp to prevent fall of materials or persons.

2.2.10 Wall Hole — An opening in any wall or partition having height of less than 750 mm but more than 25 mm and width unrestricted.

2.2.11 Wall Opening — An opening in any wall or partition having both height of at least 750 mm and width of at least 450 mm.

3 GENERAL

3.1 A general overview of construction project management and information regarding the applicable tools and techniques are covered in Section 1 'Construction Management' of this Part, which also demarcates various stages of a construction project and activities thereunder. Section 1 gives brief guidelines on project formulation and appraisal, and various construction project management functions; and for detailed guidelines on each of these, gives reference to the available good practices.

Construction planning and site management, plays an

important role in smooth progress of a building construction activity and are covered in Section 2 'Construction Planning and Site Management'. The knowledge of actual technical provisions in regard to practices relating to various building components starting from sub-structure to super-structure, play a key role in achieving the quality of building construction. Also, temporary enabling works; proper stacking and storage of materials; and well planned handling operations, have important role in proper, safe and smooth progress in construction work at site. The provisions in respect of these are covered in Section 3 'Construction Practices'.

The objectives of sound construction of buildings having requisite quality, durability and finish has to be duly dovetailed with the goals of safety whether during construction of a new building or addition/alteration to an existing building part thereof or during demolition of an existing building. Section 4 'Safety in Construction' covers provisions to these effects.

Section 5 'Repairs, Retrofitting and Strengthening of Buildings' covers repair, retrofitting and strengthening of existing buildings and Section 6 'Habitat and Welfare Requirements for Workers' deals with habitat and other welfare requirements for construction workers at site.

3.2 The objective of universal design and accessibility is to ensure that all users, including those with disabilities and elderly people are able to access all the facilities within the built environment including in the public buildings, on an equal basis. Requirements for accessibility in built environment for the elderly and for persons with disabilities as given in 13 of Part 3 'Development Control Rules and General Building Requirements' of the Code shall be complied with at all stages of the construction project.

SECTION 1 CONSTRUCTION MANAGEMENT

4 CONSTRUCTION PROJECT MANAGEMENT

4.1 General

4.1.1 A project is generally a non-recurring task having a definable beginning and end, with a definite mission and has a set of objectives and achievements. Project management is application of knowledge, skills, tools and techniques to achieve the objectives of a defined project with the aim to ensure that a project is completed within the scheduled time, authorized cost and to the requirement of quality standards. Construction project management refers to such project management when applied to construction of built facility. Project objectives depend on the requirements of the built facility. From the point of view of construction project management, project objectives may be defined in

terms of scope, time, cost and quality. This may usually take place in project appraisal stage and shall be done in accordance with the good practice [7(2)]. Information and guidelines given under **4.1.2** to **4.1.6** shall be appropriately utilized under different stages of construction project.

4.1.2 Stakeholder

Stakeholder is a person, group of persons or organizations who are actively involved in the project or those who have an interest in the success of a project and its environment. Generally in a construction project, besides the owner/client, the project manager, consultants, construction agencies and the users are the stakeholders. In addition, depending on the nature of the project, there may be other stakeholders such as financier, government and public at large.

4.1.3 Construction Project Life Cycle

Construction project life cycle consists of project formulation and appraisal, project development, planning for construction, tender action, construction, and commissioning and handing over, as main stages. These stages involve defined decisions, deliverables and completion of mile-stones for control of project, ensuring that the adverse impact of uncertainties is overcome at each stage in the progress. Accordingly, the responsibilities of project team should be defined and measured for acceptance, and liabilities determined objectively.

Project objectives, drawn out of feasibility established in the appraisal stage, are achieved progressively through each of the project life cycle stages. The stage-wise break-up of project objectives, tasks, compliance and authorization to proceed further in the next stage should be structured comprehensively through various stages of life cycle. Each stage of construction project life cycle may be considered as a subproject, thus making overall complexities of a project more manageable.

A typical construction project life cycle is given in Fig. 1.

4.1.4 Construction Project Delivery Models

Project delivery model determines the manner in which the project is planned, designed, executed and contract administration carried out. It also determines the contractual relationships between the owner/client, design consultants and construction agency. The delivery model shall define the span of control and role and responsibilities of each of the above parties. The main types of project delivery models that are in vogue in construction projects are: (a) Traditional design-bid-build, (b) Design-build with variants, (c) Turn-key and (d) Build, operate and transfer and its variants. Each

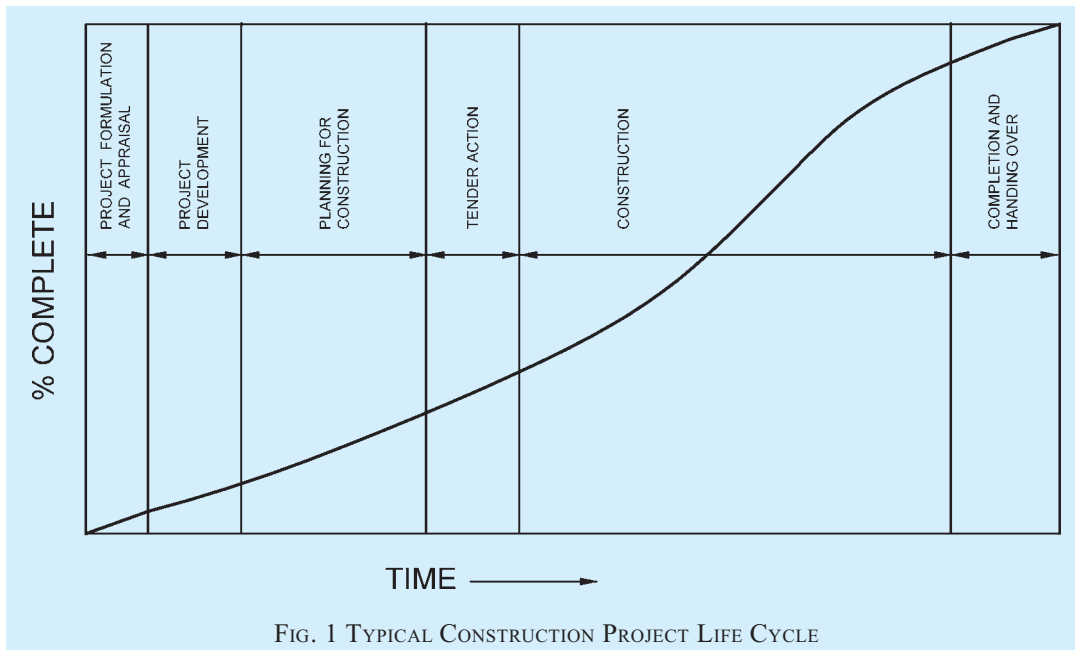

FIG. 1 TYPICAL CONSTRUCTION PROJECT LIFE CYCLE

of the delivery models can adopt different types of contracts depending upon the suitability of the contract type in relation to the nature and type of projects, project objectives and other project specific considerations.

4.1.5 Construction Methodologies and Techniques

Suitable construction methodologies and techniques, such as, conventional, prefabrication, systems building approach, mixed/composite construction, mechanization in construction and other innovative technologies, shall be defined considering design principles adopted and also considering the project objectives in terms of factors, like, scope, time, cost and quality requirements. Method statement may be made for all critical items of work.

4.1.6 Organizational Structures

Organizational structure depends on the project delivery model. As an example, a typical organization chart for Design-Bid-Build model is given in Fig. 2.

4.1.6.1 Construction project management organizational teams

For any given project delivery model, an appropriate organizational structure shall be selected so as to facilitate constitution of teams across various agencies involved. Such teams are fundamental functional units generally specific to each of the life cycle stages of a project.

Health, Safety and Environment (HSE) and quality set up shall directly report to the Project Manager.

4.2 Stages of a Construction Project

4.2.1 Typically a construction project (whether small or large) may be considered to involve the following distinct broad stages:

- a) Project formulation and appraisal stage:
 - 1) Inception,
 - 2) Feasibility, and
 - 3) Strategic planning.
- b) Pre-construction stage:
 - 1) Project development,
 - 2) Planning for construction, and
 - 3) Tender action.
- c) Construction stage, and
- d) Commissioning and handing over stage.

4.2.2 Project Formulation and Appraisal Stage

For successful management of construction projects, the earlier stages when the construction project is conceived, formulated and its feasibility assessed, leading to decision to implement the project, are equally important. The guidelines given in the good practice [7(2)] should be employed during project formulation and appraisal stage of a construction project.

NOTE — This stage of a construction project is basically the preliminary stage covering activities up to the stage of preparation of proposals for obtaining approval for implementing the project including financial approval and includes inception, pre-feasibility, feasibility, related project strategic planning and viability assessment and review prior to approval of project.

For all other above stages, the relevant construction management function guidelines given in 4.3 should be employed for achieving the intended objectives.

4.2.3 Pre-Construction

4.2.3.1 Project development

This shall involve the following:

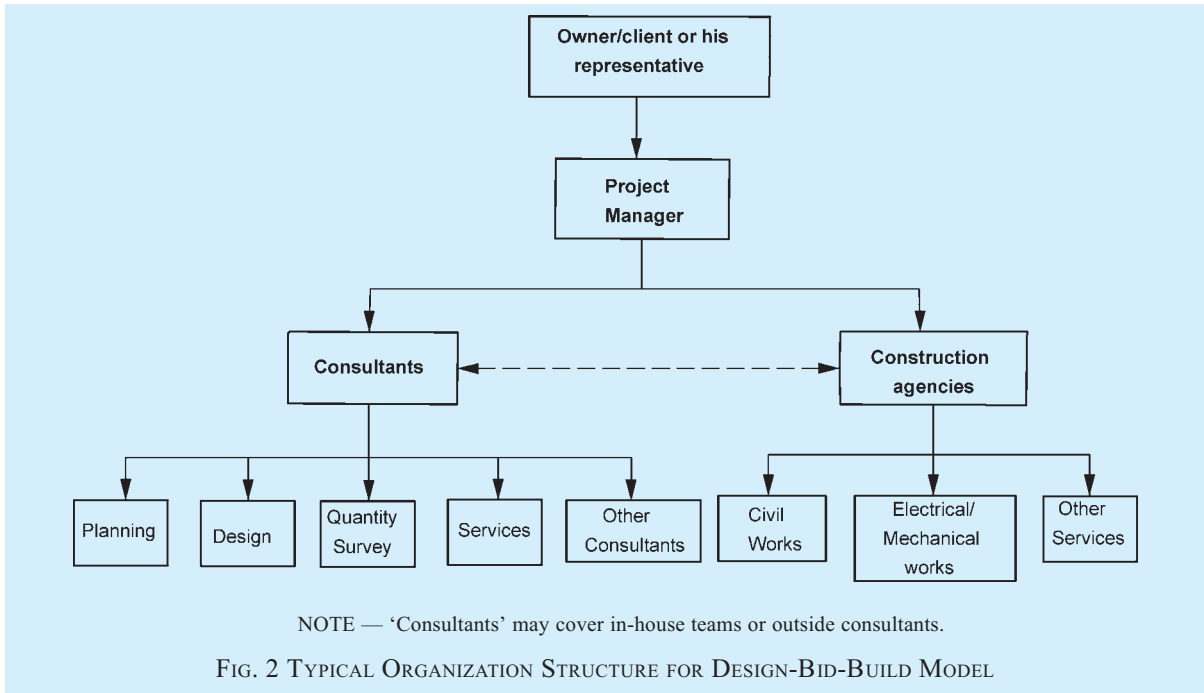

- a) Formalization of design brief;
- b) Site survey and soil investigation;
- c) Hazard risk vulnerability analysis;
- d) Alternative concept designs with costing and finalization;
- e) Preliminary designs and drawings;
- f) Development of design of each discipline and their integration;
- g) Obtaining statutory approvals;
- h) Selection of construction methodology;
- j) Preliminary cost estimates;
- k) Detailed planning and design of each discipline;
- m) Construction working drawings and related specifications with integration of engineering inputs of all concerned disciplines;
- n) Detailed cost estimates;
- p) Detailed specifications and bills of quantities; and
- q) Tender documents.

Peer review/proof checking of the drawings/designs/estimates shall be done in case of important projects, depending upon their complexity and sensitivity. Environment impact analysis and social impact analysis shall be done in applicable cases.

4.2.3.2 Planning for construction

The following aspects shall be considered:

- a) Sequencing of project components,
- b) Planning tools:
 - 1) Work breakdown structures (WBS),

- 2) Bar charts, and
- 3) Network techniques and scheduling.
- c) Resource planning, and
- d) Time cost trade off.

4.2.3.2.1 Sequencing of project components

Methodology of construction shall be detailed before the start of the project. Sequencing of project components shall be done on the basis of methodology adopted and availability of resources. This shall be reviewed during the progress of the project and revised, if necessary.

4.2.3.2.2 Planning tools

The planning tools described below may be employed for effective management of a construction project:

- a) *Work breakdown structure (WBS)* — The WBS shall identify the total scope of works involved in the project and shall form the basis for the development of detailed project schedule. Through WBS, the project shall be subdivided into major subdivisions (work packages) and each major subdivision shall be further subdivided into additional levels as required up to the level of activities that could form the basis for monitoring and control of project performance in terms of time, cost and quality parameters. WBS shall provide activity listing with associated cost account codes for the preparation of project schedule either by bar charts or by network diagramming methods.
- b) *Bar chart* — Bar chart is the simplest form of

project scheduling and used for small and complex projects and in preliminary planning and tender-stages of major projects. A typical bar chart form of project schedule depicts the various activities on a calendar time scale in the form of bars in their relative positions with start and finish dates and length of bar indicating probable activity duration. Linked bars represent the interdependencies between the activities. Bar chart type of schedule shall be used to comprehend, summarize and display the results of complex project network analysis and further monitoring and controlling process.

c) *Network techniques and scheduling*

- 1) *Network diagramming methods* — Network based project schedule shall be used for major and complex projects. In this method, the network of project activities identified through WBS is developed incorporating their logical relationships and interdependencies. The two available approaches for network diagramming techniques are arrow diagramming method (ADM) and precedence diagramming method (PDM).
- 2) *Network analysis and scheduling* — The project network incorporating the activity durations and logical relationships shall be analyzed with forward and backward pass schedule calculations to establish early and late start and finish time of activities with their available floats, critical activities, critical path and overall project duration. The project schedule is prepared in terms of calendar dates of start and finish of activities with available floats. The network schedule shall also be presented in the form of linked bar chart or in tabular format.

For details on network preparation and analysis, reference shall be made to good practices [7(3)]. Network schedule shall be prepared for all disciplines and they shall be integrated into a master control schedule.

4.2.3.2.3 Resource planning

This shall involve the following:

- a) *Resource allocation* — The feasibility of the network shall be checked with respect to manpower, equipment, materials, other resources required at the site.
- b) *Resource levelling* — It shall be done by re-allocating the slack resources from non-critical path to critical path activity in order

to obtain a reduction of time or by shifting the activities within the floats available with them, to obtain optimum uniform resource requirements.

- c) *Resource schedule* — Schedule of following resource requirements with respect to time shall be prepared on the basis of network developed and kept in the database for project control purposes:
 - 1) Technology,
 - 2) Manpower:
 - i) Technical staff,
 - ii) Skilled labour,
 - iii) Unskilled labour,
 - 3) Machinery,
 - 4) Materials, and
 - 5) Cash flow.

Resource schedule shall be prepared separately for client, consultant and construction agency.

4.2.3.2.4 Time cost trade off

Time cost trade off analysis shall be done to obtain a minimum total cost of the project within the specified time. This shall be done taking into consideration direct cost and indirect cost of the project.

4.2.3.3 Tender action

4.2.3.3.1 Preparation of tender documents

The bill of quantities, specifications, drawings and conditions of contract should be prepared on the basis of design and details finalized in project proposal development stage (*see 4.2.3.1*) keeping in view the construction project delivery model selected. The format, terminologies and terms and conditions should be as per the standard engineering practices. In case of any special item or condition, the same shall be described clearly to avoid any ambiguity.

4.2.3.3.2 Selection of construction agency

Selection of construction agency shall be done by either:

- a) *Open competitive bidding* — In this case, tender notice should be publicized adequately to obtain competitive tenders from competent agencies for the project; or

NOTE — Electronic tendering could also be considered.

- b) *Limited competitive bidding* — In large, specialized and important works, prequalification of contractors shall be done considering their financial capability, bid capacity, experience of similar type of works, past performance, technical staff, and plants and machinery available.

4.2.3.3.3 *Bid evaluation, negotiation and award of work*

After due evaluation and negotiation with the bidders, if required, the work shall be awarded to the construction agency based on competitive technical and financial bids.

4.2.4 *Construction*

This is one of the most important stages of construction management where pre-construction stage outputs are realized into physical tangible form within the constraints of time and cost. The intent or need for functional and physical characteristics, defined in the pre-construction stage outputs through specifications, drawings and consolidated project brief is realized through various construction project management functions described in 4.3 and particularly through procurement management, time management, cost management, quality management and health, safety and environment management.

4.2.5 *Commissioning and Handing Over*

After all construction activities of the project are complete as per specifications and designs, project commissioning and handing over stage follows. It shall need the compliance of the following:

- a) Clearing of site,
- b) Removal of all defects at the time of completion and during defect liability period,
- c) Preparation of list of inventories,
- d) Certification and settlement of construction agency's final bills for payment,
- e) Obtaining completion certificate from local government bodies/departments,
- f) Preparation of maintenance manual,
- g) Performance compliance verification of built facility,
- h) Handing over all other required documents, including guarantees, to the client/owner,
- j) Restoration of surroundings, and
- k) Preparation and handing over all as-built drawings.

4.3 **Construction Project Management Functions**

Construction project management consists of number of processes and these can be grouped under the following management functions:

- a) Scope management,
- b) Procurement management,
- c) Time management,
- d) Cost management,
- e) Quality management,

- f) Risk management,
- g) Communication management,
- h) Human resources management,
- j) Health and safety management,
- k) Sustainability management,
- m) Integration management, and
- n) Other management processes.

The project management functions briefly described below may be employed for effective management of construction project during its different stages as applicable. Some of the processes may, however, overlap more than one function.

4.3.1 *Scope Management*

It should be ensured that project concept, details and functions which are established and recorded during the finalization stage, remain same except minor changes and/or authorized variations. Scope management includes the processes of scope planning, scope definition, scope verification, scope monitoring, and change control.

Scope planning, scope definition and scope verification are associated with the preconstruction phase of the project. Scope monitoring and change control are critical to the construction/installation stage in order to control time and cost over-runs. The work break down structure of the project shall be the basic tool for defining the scope baseline. Scope control should aim to identify factors influencing scope change, determine the impact of scope changes and establish the system for scope change approval and revision of scope baseline. Accordingly, a detailed scope management plan should be drawn to lay down all the necessary practices including technical and organizational interfaces.

For detailed guidelines, reference shall be made to good practice [7(4)].

4.3.2 *Procurement Management*

Procurement management includes processes for purchase of materials, equipment, products, soliciting services of consultants and engaging agencies for execution of works under a contract. Project procurement processes, which depend on type of project delivery model include identification of procurement needs, preparation for procurement, soliciting proposals, selection of suppliers/consultants/works contractors, administering of contract, contract management and closure of contract. Project manager is charged with the responsibility to help structure and develop contract to suit the specific needs of the project. As contract, which is an output of project procurement management processes, is a legal document, the procurement processes should follow detailed

procedures with adequate review and stakeholder appraisal opportunities.

One of the fundamental issues in construction projects, managed through project managers, is to determine what needs may be met by procuring products, services and works from external agencies and what should be accomplished by the project team. This decision is best arrived at the earlier stages of the project (so that the opportunities of procurement initiation at earlier stages is not lost) and reviewed at each of the subsequent life cycle stages of the project. Such decisions should draw inputs from the time, cost, quality and scope management processes. Various procurement routes should be analysed on their suitability to both time and cost criteria of project. As a strategy for procurement, a project procurement management plan should be developed to document: contract types to be used; procurement documents; coordination of procurement with schedules; constraints and assumptions; risk mitigation activities (performance bonds, insurances, etc); and pre-qualification of suppliers. In addition, specifications, quality standards, performance data at work locations, etc, which are part of project scope statement, should be described. Inventory management plays an important role in the procurement management process.

Provision of establishment of suitable dispute redressal system should be inbuilt to take care of any disputes that may arise.

For detailed guidelines, reference shall be made to good practice [7(5)].

4.3.3 Time Management

Time management aims to complete the project within the stipulated time period. Time management essentially involves the following processes:

- a) Defining project scope in the form of work breakdown structure to generate activity identification and listing,
- b) Activity duration estimating,
- c) Activity sequencing with interactivity dependencies,
- d) Project schedule development, and
- e) Project schedule control.

Work breakdown structure should be used as a tool to prepare the project schedule by defining the project scope and identifying and listing of the activities in the work packages. For the quantum of work involved in the activities, the activity durations are estimated based on the standard productivity norms for different trades of work. Past-documented experience and expertise should also be used for determination of the activity durations with the construction technology adopted and

manpower and equipment resources used. Based on the construction methodology proposed with the consideration of project specific constraints, the sequencing and interdependencies of the activities are determined and the graphical representation of activities in the form of network should be prepared. The network thus prepared should be analysed to develop the project schedule with information on early and late start and finishing of activities with their available floats and the critical path/critical activities on the network. Incorporating the calendar dates, the baseline schedule may be finalized with the incorporation of milestones for subsequent schedule monitoring and control processes.

During the construction stage, schedule monitoring involves methods of tracking and comparing the actual schedule with the baseline schedule and schedule control activities should ensure to remove deficiencies and slippages corrected to acceptable levels.

Project scheduling and monitoring is a dynamic process and periodic schedule updating should be done for effective monitoring and control process. In the process, the status of each activity should be examined. For completed activities, actual durations utilized, are incorporated; and for activities in progress, balance to complete revised durations and estimated finish dates are determined and incorporated. If the actual schedule lags behind the baseline schedule, various options should be considered to control and bring back the schedule to acceptable levels. The possible control actions, which may be considered, are: possible reduction in activity duration of future activities with alternate technology options, increasing the resources, alteration in the construction logic and activity sequencing, etc.

For detailed guidelines, reference shall be made to good practice [7(6)].

4.3.4 Cost Management

The objective of the project cost management is to ensure that the project is completed within the authorized budget. The major processes involved in the cost management are: resource planning, cost estimation, cost budgeting/cost planning and cost monitoring and control. The resource planning involves determination of various types of resources, such as appropriate technology, workforce, materials, equipment and infrastructure facilities, their quantum and their requirements during different stages of the project. Preliminary cost estimate with defined scope of work is required for obtaining the project sanction. Detailed item wise cost estimates with bill of quantities and specifications should be made for tendering and subsequent project execution. The type of contract

adopted such as item rate, percentage rate, lump sum and cost plus, influences the cost management strategy.

Most of the cost optimization techniques through value engineering studies are achieved during the preconstruction stage of the project. Value engineering is a useful technique for application in cost management. It is a systematic multi-disciplinary effort directed towards analyzing the functions of project or item for the purpose of achieving the best value at the lowest overall life cycle project cost. It is an established technique for determining value based decisions rather than cost reduction based on change in specifications. Suitability of construction techniques, selection of equipment for specific purposes, considering alternative materials and other design changes are some of the areas of application of value engineering.

During construction stage, the efforts are more on control mode for adherence to the budgeted cost. For the purpose of cost control during execution, the time based cost baseline of the project which forms the basis for the measurement and monitoring of cost performance, should be generated. The cost baseline is generated by allocating the overall cost estimate to individual project activities based on the project schedule. Using the cost baseline, the cost control, which comprises the following, should be exercised:

- a) Periodical cost reporting,
- b) Comparison of the actual cost against the planned cost,
- c) Obtaining early warning for corrective actions,
- d) Control and monitoring cost changes,
- e) Forecasting of final cost at completion based on cost trend and cost changes, and
- f) Modification of the cost baseline for authorized cost changes and preparation of revised estimates.

For detailed guidelines, reference shall be made to good practice [7(7)].

4.3.5 Quality Management

Quality management in construction aims to achieve required functional and physical characteristics of a constructed facility through management actions including planning, direction and control. Quality is the key determinant of requirements which is expressed through drawings and specifications. Main function of quality management is to achieve quality objective of satisfying requirements through performance evaluation of construction processes and ensure that they are directed towards overall quality. Quality management during construction stage assumes that the design and specifications comprehensively incorporate requirements of users and other stakeholders. Prior to

setting out for the construction, the client should completely understand the implications of changes to the design and specifications during the construction stage, which may affect quality.

Although quality is an all-encompassing concept which also has bearing on time and cost aspects, the specific scope of quality management may be limited to its key functions of quality planning, quality assurance and quality control. Quality planning refers to the identification of relevant quality standards and determining how to satisfy them. Quality assurance activities include consistent evaluation of project performance to provide confidence that the project satisfies the relevant quality standards. Quality control monitors project results related to the compliance to quality standards and identifying means to eliminate non-conformity.

On-site operations constitute most of the construction processes. Scope of quality management for on-site operations may be categorized broadly in three distinct stages. In the receiving stage, materials and supplies are inspected and tested for conformance to the specified standards. During 'in-process stage', materials and supplies are processed to form project product components wherein process control ensures conformance to the specified standards. In the 'final stage', inspections and tests monitor the functional and physical performance of the product/service to ensure that they satisfy the requirements.

Planning being an integral part of the quality management, may also consider efficient site layout and its management for on-site operations. In addition to time and cost implications of the site management, the quality performance improves by efficient organization of activities by way of providing adequate and appropriate conditions for the work processes. Site management needs to consider construction technology constraints with reference to aspects related to space availability such as permanent services, access to site, temporary services, location of material stores, stacking and storage areas and plants, fencing and other temporary structures.

The various organizations connected with the project should have their own quality management systems.

For detailed guidelines, reference shall be made to good practice [7(8)].

4.3.6 Risk Management

Project risks have an impact on the project objectives and need a planned response. Project risk management processes ensure proper planning, identification, analysis, monitoring and control to the best interest of the project.

Risk management planning processes develop an approach to risk management activities which include planning, execution and monitoring. A risk management plan should define lead and support role responsibilities of project team in relation to management, budgeting, risk responsive scheduling, classification of risk activities based on risk break-down structure and explanation of probability and impact for risk context.

Risk response planning determines actions required for reducing impact of risks. Risk responses are established and assigned to appropriate project participants. Suitable risk mitigation measures should be evolved for identified risks.

For detailed guidelines, reference shall be made to good practice [7(9)].

4.3.7 Communication Management

For communication management, Management Information System (MIS) is used as an important tool for systemized approach to furnish information. It comprises a system that collects, stores, sorts and analyses data to generate and communicate information. It may be a combination of manual and computerized systems.

At the construction stage of a project, there are many agencies involved like client, architect, engineer, project manager, various consultants, material suppliers, construction agencies and sub-contractors. Each agency is divided into top level management taking policy decisions, middle level management monitoring the project and lower level management involved in day to day operations of the project.

Each level of management requires information of varying details, at different periodicities and in different formats. Project progress information flows from lower level to the top level management and policy decisions flow from top level to the lower level management.

MIS integrates the work and information flow within each agency and flow of information between different agencies.

In construction stage of the projects, the information may be in the form of data reflecting status of project in terms of actual execution time for each activity, cost incurred, resources used, quality control, material management, bills, organization management and other administrative aspects like disputes that may come up. This data should be analysed to understand the overall progress achieved and to update schedules of the project.

Basic objectives of MIS of a construction project may be summarized as:

- a) Providing benchmark against which to

measure or compare progress and costs, like time network schedules, cost estimates, material and labour schedules, specifications, working drawings.

- b) Providing an organized and efficient means of measuring, collecting, verifying and reflecting the progress and status of operations on the project with respect to progress, cost, resources and quality.
- c) Providing an organized, accurate and efficient means of converting the data from operations into information.
- d) Reporting the correct and necessary information in the required format and at the required level of detail to managers at all levels and to the supervisors.
- e) Identifying and isolating the most important and critical information at various stages to be communicated to the managers and supervisors for taking decisions.
- f) Communicating the information to the managers and supervisors in time so that decisions may be taken at the right time.

Total MIS configuration of the construction project may be divided into the following modules:

- 1) Planning and scheduling module,
- 2) Cost control and accounting module,
- 3) Trend and forecast module,
- 4) Project administrative and financial module, and
- 5) Historical and documentation module.

All modules should be interlinked in flow of information and generation of reports.

For large public projects, suitable mechanism may be established for communication of relevant information to public at large.

For detailed guidelines, reference shall be made to good practice [7(10)].

4.3.8 Human Resource Management

All construction projects involve large number of skilled/unskilled persons. Human resources in a project should be adequately qualified, trained and competent.

Quality of construction work depends on the quality of labour resource. For skilled and un-skilled labour, the requirement for technical knowledge, skill and general awareness are varied for different construction processes. Labourers are required to understand their respective responsibilities especially towards the work. Therefore, construction management practices should emphasize on development of competence of this critical human resource through training programmes.

The critical activities should be identified from the point of view of technological innovations, workmanship and environmental conditions which determine labour behaviour and performance. In each construction project, there are certain work related peculiarities which call for job specific orientation. There should be a clearly defined competence requirement for the workers. Progressively, a formal training or a certified course undertaken should be a preferred selection criterion for the workers. All efforts should also be made to impart on site skilling/training of construction workers for specific tasks. A periodic review of the performance may be made to establish the nature of training required and methods for imparting training. There is a need to address the motivational aspects, for better performance.

For detailed guidelines, reference shall be made to good practice [7(11)].

4.3.9 Health and Safety Management

4.3.9.1 Health management issues include looking into the risk factors to health of construction personnel and providing hygienic conditions at construction sites and methods of their management. It includes managing,

- a) occupational/physical health hazards.
- b) short term as well as long-term ill effects of the activities and the working environment of the construction sites.
- c) provision of personal protective equipment required for specific health hazards.
- d) laying down of construction hygiene control methods.

4.3.9.2 Safety management issues include managing work processes, equipment and material handling at site for striving to achieve zero accident status at site. For prevention and management of accidents, a proper organizational and administrative mechanism is required. Following steps should be taken for achieving the same:

- a) Laying down of safety regulations or mandatory prescriptions concerning different work processes.
- b) Standardization of work processes and management actions.
- c) Regular and stipulated inspection of works and machinery/equipment for enforcement of mandatory regulations.
- d) Providing education and training to workers on safety issues.
- e) Publicity and appeal to develop safety consciousness.
- f) Insurance of built facilities, construction personnel and third party.

- g) Regular safety audit of construction sites and post audit actions.
- h) Effective post-accident action including accident analysis and reporting.
- j) Effective post-accident management including corrective measures to avoid repetition of such accidents.

Safety Officer shall be appointed in accordance with the concerned provisions of the *Building and Other Construction Workers (Regulation of Employment and Conditions of Service) Act, 1996*. Safety officer who is posted at a medium to major construction site shall:

- 1) Look after the safety of the personnel, safe handling of materials and machinery, safe work practices and standard operating procedures.
- 2) Be responsible for compliance of all statutory obligations of the employer in regard to safety of personnel and structures.
- 3) Guide and assist the site managers/engineers to make their sites safe and accident free.
- 4) Train personnel in construction safety, conduct safety surveys and design suitable documents for recording and promoting safety on sites and in the construction industry.
- 5) Arrange for safety briefing for all the persons entering the construction area.

For detailed guidelines, reference shall be made to good practice [7(12)].

4.3.10 Sustainability Management

4.3.10.1 Sustainability management issues include the following:

- a) Minimizing adverse environmental impact of activities, products and services.
- b) Limiting any adverse impact within the laws/prescribed norms and their monitoring.
- c) Safety of environment while working with hazardous materials and maintaining material safety data sheets.
- d) Management of disposal of waste from the construction sites.
- e) Considering positive environmental contribution particularly after completion of construction.
- f) Mechanism to review concerns of interested parties.

For detailed guidelines, reference shall be made to good practice [7(13)].

4.3.11 Integration Management

Integration management aims to provide processes

necessary for coordination amongst various organizations and their teams involved. It ensures that various organizational teams perform in an integrated manner, with their actions coordinated to the mutual interests towards the project. Integrated management processes provide opportunities for resolving conflicts and competing interests through appropriate tradeoffs. Integration is necessary where processes interact, especially when process responsibilities belong to different organizational groups. Such process interactions need organizational interfaces to be defined and resolved at an overall level.

Integration management may also be required for specific situations when impact of one management function is a cause for concern for other management functions. For example, if there is a time delay in performing a particular construction process, it may often have impact on the cost aspects of not only that process but other processes involving other organizational groups; the rescheduling may affect coordination amongst performing groups in the downstream processes and activities.

For detailed guidelines, reference shall be made to good practice [7(14)].

SECTION 2 CONSTRUCTION PLANNING AND SITE MANAGEMENT

5 PLANNING ASPECTS

Construction planning aspects aim to identify and develop various stages of project execution on site which should be consistent with the management considerations. Planning aspects evolve out of the objectives of project and requirements of the final completed constructed facility. These objectives could relate to the time constraints, cost considerations, quality standards, safety standards, environmental considerations and health considerations. Construction practices would, then have to satisfy these objectives during construction phase of the project.

Having established objectives of the construction phase, planning determines processes, resources (including materials, equipment, human and environmental) and monitoring system to ensure that the practices are appropriately aligned. Adequate knowledge about preconstruction phase evolution of project, especially related to customer's requirements, is an essential prerequisite for construction planning.

5.1 Preconstruction Phase

5.1.1 Besides the design aspects, preconstruction phase should also address all the issues related to the implementation of the design at the site through suitable construction strategy. During the design stage, the site

conditions should be fully understood with anticipated difficulties and avoid the risk of subsequent delays and changes after the construction has started.

5.1.2 The selection of construction methods, building systems and materials, components, manpower and equipment and techniques are best done in the preconstruction phase. Such selection is influenced by the local conditions like terrain, climate, vulnerability for disasters, etc.

5.1.3 Construction in busy localities of cities needs special considerations and meticulous planning due to restricted space, adjoining structures, underground utilities, traffic restrictions, noise and environmental pollution and other specific site constraints.

5.1.4 The constructability aspects of the proposed construction methods needs to be carefully evaluated at the planning stage to ensure ease of construction besides optimizing the construction schedule and achieving quality, reliability and maintainability of the constructed facilities.

5.1.5 Construction practices in hilly regions needs to take into considerations the problem of landslides, slope stability, drainage, etc, besides ensuring no adverse impact on the fragile environmental conditions.

5.1.6 Durability of constructions in corrosive atmospheric conditions like coastal regions and aggressive ground situations with high chlorides and sulphates should also be taken care of with appropriate construction practices.

5.1.7 Construction practices in disaster prone areas need specific planning. The type of construction, use of materials, construction techniques require special considerations in such areas.

5.1.8 Adverse weather conditions have strong bearing on construction phase. Situations wherein constructions are to be carried out in adverse weather conditions, such as heavy and continuous rain fall, extreme hot or cold weather, dust storms, etc, the practices have to address the relevant aspects. Accordingly, suiting the site conditions, the design and field operations should be adapted or redefined based on considerations, such as the following:

- a) Site layout which enables accessibility in adverse weather.
- b) Adequate protected storage for weather sensitive materials/equipment.
- c) Protection to personnel from extreme hot/cold conditions.
- d) Scheduling to allow maximization of outdoor activities during fair weather conditions.
- e) Special design and construction provisions for

activities in extreme temperature conditions like hot or cold weather concreting, stability of false work in extreme wind conditions (gusts).

- f) Adequate lighting for shorter days in winter/night work.
- g) Design for early enclosure.

5.2 Resource Planning

Resource planning aims to identify requirement, availability and regulatory/control processes related to resources. Resource planning is a generic expression but the actual process of planning is specific to the resources considered (*see also 4.2.3.2.3*).

In construction phases, the resources could be categorized as materials, manufactured products, equipment for construction, installation and fabrication, human resources as a part of overall organization, information resources such as reference standards and other practice documents, environmental conditions for work on site, infrastructure facilities and cash flow. Therefore, the resource planning encompasses identification, estimation, scheduling and allocation of resources. Resource planning needs to establish a control system for controlling consumption monitoring, corrective action and resource reappropriation in the event of favourable deviation. Organizational capability, commitment to the project requirements and other constraints such as time and cost, need to be considered as inputs while planning resources. Techniques of management and planning such as Programme Evaluation and Review Technique (PERT) and Critical Path Method (CPM) may be used.

Non-availability of basic building materials (brick, stone, aggregate, etc) within reasonable lead would influence the construction practice by alternative materials. The construction practices also get decided by the local skills of the manpower for construction activities. The equipment selection would also be governed by the site constraints. Source of funding of the project and its timeliness with reference to requirement of cash flow should also merit consideration. Therefore, as, the resource planning is critical to the project viability itself, the inputs to the resource planning need to be validated appropriately and established for such management. Resource planning should establish a proper system of data collection so as to facilitate effective resources control mechanism. Resource planning responsibility has to be specifically defined in the overall organizational setup.

5.3 Construction Phase

5.3.1 Organizational Structure

The site management should be carried out through

suitable site organization structure with roles and responsibilities assigned to the construction personnel for various construction related functions.

5.3.2 Site Management

5.3.2.1 Site layout

The layout of the construction site should be carefully planned keeping in view the various requirements of construction activities and the specific constraints in terms of its size, shape, topography, traffic, and other restrictions, in public interest. A well planned site layout would enable safe smooth and efficient construction operations. The site layout should take into considerations the following factors:

- a) Easy access and exit, with proper parking of vehicle and equipment during construction
- b) Properly located material stores for easy handling and storage.
- c) Adequate stack areas for bulk construction materials.
- d) Optimum location of plants and equipment (batching plants, etc).
- e) Layout of temporary services (water, power, power suppression unit, hoists, cranes, elevators, etc).
- f) Adequate yard lighting and lighting for night shifts.
- g) Temporary buildings; site office and shelter for workers (*see 14*) with use of non-combustible materials as far as possible including emergency medical aids.
- h) Roads for vehicular movement with effective drainage plan.
- j) Construction safety with emergency access and evacuations and security measures.
- k) Fabrication yards for reinforcement assembly, concrete precasting and shuttering materials.
- m) Fencing, barricades and signages.

5.3.2.2 Access for firefighting equipment vehicles

Access for firefighting equipment shall be provided to the construction site at the start of construction and maintained until all construction work is completed. Free access from the street to fire hydrants/static water tanks, where available, shall be provided and maintained at all times. No materials for construction shall be placed within 3 m of hydrants/static water tanks. During building operations, free access to permanent, temporary or portable first-aid firefighting equipment shall be maintained at all times.

5.3.2.3 Access to the upper floors during construction

In all buildings over two storeys high, at least one

stairway shall be provided in usable condition at all times. This stairway shall be extended upward as each floor is completed. There shall be a handrail on the staircase.

5.3.2.4 Electrical installations

Electrical installations, both permanent and temporary, for construction and demolition sites, including electrical installations for transportable construction buildings (site sheds) shall be in accordance with 12 of Part 8 'Building Services, Section 2 Electrical and Allied Installations' of the Code.

5.3.3 Construction Strategy and Construction Sequence

Construction strategy and construction methods are to be evolved at the planning and design stage specific to the conditions and constraints of the project site and implemented by the site management personnel to ensure ease of construction and smooth flow of construction activities. Sites of high water table conditions with aggressive chemical contents of subsoil needs special design considerations. Buildings with basement in sites of high water table should be planned with dewatering scheme with appropriate construction sequence. Duration of dewatering should continue till sufficient dead loads are achieved to stabilize the buoyancy loads with adequate factor of safety. The construction sequence should be planned taking into consideration the following aspects:

- a) Availability of resources (men, material and equipment);
- b) Construction methods employed including prefabrication;
- c) Planned construction time;
- d) Design requirements and load transfer mechanism;
- e) Stability of ground like in hilly terrain;
- f) Ensuring slope stability with retaining structure before the main construction;
- g) Installation and movement of heavy equipment like cranes and piling equipment;
- h) Effect of weather; and
- j) Minimum time to be spent on working below ground level.

SECTION 3 CONSTRUCTION PRACTICES

6 CONSTRUCTION CONTROL AND PRACTICES

6.1 Professional Services and Responsibilities

The responsibility of professionals with regard to planning, designing and supervision of building

construction work, etc and that of the owner shall be in accordance with Part 2 'Administration' of the Code. All applications for permits and issuance of certificates, etc shall be as given in Part 2 'Administration' of the Code. Employment of trained workers shall be encouraged for building construction activity.

6.2 Site Preparation

6.2.1 While preparing the site for construction, bush and other wood, debris, etc, shall be removed and promptly disposed of so as to minimise the attendant hazards.

6.2.2 Temporary buildings for construction offices and storage shall be so located as to cause the minimum fire hazards and shall be constructed from non-combustible materials as far as possible.

6.3 Habitat for Construction Workers at Site

The habitat and other welfare measures for construction workers shall meet the requirements specified in 14.

6.4 Construction of All Elements

6.4.1 Construction of all elements of a building shall be in accordance with good practice [7(15)]. It shall also be ensured that the elements of structure satisfy the appropriate fire resistance requirements as specified in Part 4 'Fire and Life Safety' of the Code, and quality of building materials/components used shall be in accordance with Part 5 'Building Materials' of the Code.

6.4.2 Construction of all accessibility features/elements in a building and its built environment shall be as per the requirements given in 13 of Part 3 'Development Control Rules and General Building Requirements' of the Code.

6.4.3 All mechanical, electrical and plumbing (MEP) and other services in a building shall be installed in accordance with approved designs as per Part 8 'Building Services' of the Code and Part 9 'Plumbing Services including Solid Waste Management' of the Code. Proper sequencing of installation of various services shall be done for ensuring smooth construction activities.

6.4.4 Necessary temporary works required to enable permanent works, shall be executed in accordance with 7.

6.5 Low Income Housing

For low income housing, appropriate planning and selection of building materials and techniques of construction have to be judiciously done and applied in practice. Requirements of low income housing specified in Part 3 'Development Control Rules and

General Building Requirements' of the Code shall be followed. However, all requirements regarding structural safety, health safety and fire safety shall be in accordance with this Part.

6.6 Use of New/Alternative Construction Techniques

The provisions of this Part are not intended to prevent use of any construction techniques including any alternative materials, not specifically prescribed by the Code, provided any such alternative has been approved. The Authority may approve any such alternative, such as, ferrocement construction; stretcher bond in filler slab; glass fibre reinforced gypsum (GFRG) panel system using composite of GFRG panel and reinforced concrete; pre-engineered steel structures with reinforced concrete expanded polystyrene core based panel/other in-fill walls; light gauge steel framed structures with suitable water resistant wall panels like cement bonded particle board, provided it is found that the proposed alternative is satisfactory and conforms to the provisions of relevant parts regarding material, design and construction and that material, method, or work offered is, for the purpose intended, at least equivalent to that prescribed in the Code in quality, strength, compatibility, effectiveness, fire and water resistance, durability and safety.

6.7 Urban Roads/City Roads Planning and Construction

6.7.1 The urban roads, which are commonly known as city roads/streets have been under constant development. The emphasis has been primarily on providing essentially required width of metalled surface for the movement of vehicles (both motorized and non-motorized). Footpaths of various widths and heights are required to be provided.

The space between the buildings and the city roads should be treated as valuable and important space allowing for a comfortable and safe use by the pedestrians, hawkers, cyclists including non-motorized vehicle (NMV) drivers, and adequate space for drainage, utilities, street lighting poles, transformers and trees. Thus, the objective should be to create urban streets/roads that are efficiently planned, safe for vehicles as well as pedestrians, universally user friendly, and sustainable.

The elements required in an efficiently planned street, such as, kerb stones; kerb channels; kerb ramps; tactile ground surface indicators; silt chambers with manhole cover; drain cover slabs; drain manhole covers; service pipes; manhole covers for electrical services; manhole covers for telecom services; cycle tracks (NMV); bollards across pedestrian paths; tree gratings; lighting poles on main roads and service roads; table tops on free left turns; pedestrian paths at intersections/

T-junctions; pedestrian paths on traffic islands; pedestrian paths across central verge; pedestrian paths near rotaries (un-signaled); pedestrian paths below flyovers; signages; traffic signals; cable ducting by discoms; central verge irrigation system; central verge, footpath and traffic islands plantation; street furniture; bus queue shelters; public art, public toilets, etc. should be identified. These elements should be integrated at the planning stage, indicating the methodology of execution, taking care of the following while complying with the relevant rules/regulations:

- a) Road cross-section planning based on land-use with emphasis on smooth vehicular movements.

NOTE — This may be achieved by rationalizing lane widths based on norms laid down by Indian Roads Congress.

- b) Design of road intersections, fixing of geometrics of roads, providing provision of entry and exits from the service roads.
- c) Coordination between the traffic police, transport authorities and the executing agencies to be ensured for efficient location of traffic signals, zebra crossings and the bus queue shelters and the pickup stands for the para-transport.
- d) Standardization of kerb stones, kerb ramps and kerb channels.
- e) Appropriate selection of materials, like, paver blocks, tiles, stone slabs or plain cement concrete for footpaths, plazas, etc, so that they add to aesthetics of buildings and roads.
- f) Standardization of access manhole covers for various utilities.
- g) Providing footpath at one level by adjusting the drain cover slab levels.
- h) Integration of bus queue shelters with the footpath.
- j) Pedestrian friendly access across the roads to the foot-over bridges, subways and public toilets.
- k) Access to gates of residential/commercial properties integrated with the road through the footpath in front.
- m) Sharing of NMV with footpath necessary at many locations.
- n) Adequate provision of public conveniences and dust bins.
- p) Street lighting for proper illumination of roads and service roads including modifications of street lighting along with central verge and the service roads blocked by existing trees.
- q) Low height plantation on central verges, avoiding plantation of trees.

- r) Removal of crooked trees on footpaths for proper and safe utilization of footpath.
- s) Removal of trees obstructing the carriage ways and their replantation, wherever feasible.
- t) Freeing of trees embedded in the compound wall/dwarf walls on footpaths to save both the trees and the walls.
- u) Providing planters in the central verge in the deck portion of flyover to ensure proper glare cutting during night hours and improving aesthetics during the day.
- w) Proper location of signage boards so as to be safe from moving traffic near the footpath edges and give clear visibility.
- y) Selection, procurement and installation of street furniture.
- z) Selection, procurement and installation in respect of accessibility features as per the requirements given in 13 of Part 3 'Development Control Rules and General Building Requirements' of the Code.

NOTE — The relevant standards/publications of Indian Roads Congress may be referred to.

6.7.2 The road work zones are areas of conflict between normal operating traffic, construction workers, road building machineries and construction traffic. If it is a construction of new road, normal operating traffic will not be there but the care has to be taken to avoid and or remove conflicts between workers and construction machineries and construction traffic. Problem becomes more serious if it is an urban road with significant proportion of vulnerable road users. The road work zones and the traffic around them should be so planned and managed so as to ensure traffic safety, facilitate smooth and efficient flow of traffic and also provide safe working environment for the workers.

NOTE — For guidance on management of pedestrians/cyclists/vehicles near road construction sites, reference may be made to IRC SP 55 : 2014 'Guidelines on traffic management in work zones'.

6.8 Measures against pollution and hazard due to dust, smoke and debris, such as screens and barricading shall be installed at the site during construction. Plastic/tarpaulin sheet covers shall be used for trucks transporting fine materials liable to cause environmental pollution.

7 TEMPORARY WORKS

7.1 The construction of most types of permanent works requires the use of some form of temporary works. Temporary works are the parts of a construction project that are needed to enable the permanent works to be built. Usually the temporary works are removed after use, for example, access, scaffolds, props, shoring,

excavation support, false work and formwork, etc. Sometimes the temporary works are incorporated into the permanent works, for example, haul road foundations and crane or piling platforms which may be used for hard standing or road foundations. The same degree of care and attention should be given to the design and construction of temporary works as to the design and construction of the permanent works. Considering that as temporary works may be in place for only a short while, there is a tendency to assume they are less important, which is incorrect. Lack of care in design, selection, assembly, etc, leaves temporary works liable to fail or collapse. While organizing the temporary works, aspects as given below should be followed:

- a) The person organizing the temporary works should be aware of the problems that can occur at each stage of the process and how to prevent these. They need to coordinate design, selection of equipment, appointment of contractors, supervision of work, checking completion, authorization to load and removal.
- b) If so required, a temporary works co-ordinator (TWC) may be employed in case of medium and large projects, whose requisite qualification and experience should be specified. The role of TWC and supervisor should be decided. The coordinator shall have adequate field training for temporary works. The contractor shall ensure that work is allocated and carried out in a manner that does not create unacceptable risk of harm to workers or members of the public. On projects with relatively simple temporary works needs, a TWC may be avoided, however, it shall be ensured that temporary works are properly managed.
- c) The cost of any temporary works is generally included in the build-up of the tender.
- d) Temporary works are often taken from site to site and re-used and it is important to consider the robustness of components in their design. However, temporary works that are designed only to be used during construction shall not be removed until the satisfactory safety criteria for their use has been met.
- e) Proper planning and co-ordination should be done in respect of sequence and timely execution of temporary works, as also for ensuring that they are correctly installed, used, checked and maintained.
- f) In each of the cases of temporary works, the person organizing the temporary works should assess the soil conditions to be sure that it is

suitable for the equipment involved, and check that any assumptions made in the calculations for the standard solution are valid for this particular situation and the conditions on site. On a simple job, the supplier's data will allow an experienced person to consider the necessary issues without further calculation.

- g) Propping using standard equipment such as screw props (acrows) needs careful consideration. To select the type, size, number and decide spacing, information is needed about the loads that will act on the props. This will include the wall above and the additional load from any other floor or roof beams, etc, that enter the wall above or close to the opening. Even with proprietary equipment, the support system shall be worked out.
- h) A local failure within the temporary works should not initiate a global collapse of the structure. Therefore, additional care should be taken while removing temporary works.

The different types of temporary works can be scaffolding, crane supports, falsework, formwork, and trench support. Detailed knowledge about each type of temporary work is necessary for safe construction. The requirements as given in 7.2 to 7.6 shall be satisfied in case of temporary works.

Proprietary equipment supplier should be identified and approved. It should be ascertained, whether following has been performed:

- 1) They have designed the foundations,
- 2) Any assumption made that have to be confirmed/investigated,
- 3) Independent checking done and by whom,
- 4) Status of drawings, and
- 5) Procedures checked at site.

In management of temporary works, the owner/client has to ensure,

- i) checks on competence on designers;
- ii) steps taken to ensure co-operation between the permanent and temporary works designers;
- iii) coordination at site meetings; and
- iv) advise clients on the suitability of the initial construction phase plan, that is, the arrangements for controlling significant site risks.

7.2 Scaffolding

Scaffolding includes providing a temporary safe working platform for erection, maintenance, construction, repair, access, and inspection. Scaffolding and their erection shall be in accordance with the good practice [7(16)].

7.3 Tower Cranes

Tower cranes are usually supplied on a hire basis, with the client being responsible for the design and construction of the base upon which the crane is erected. Details of loading are provided by the crane supplier and the base is most commonly designed as a temporary structure, though sometimes a crane base is incorporated into the permanent structure to save on cost and time.

Loads are given in two forms, 'in service' loads, where the crane is functioning and wind speeds are restricted (that is, cranes will not operate at high wind speeds), and 'out of service' loads, where the crane is not being used but maximum wind speeds may occur.

The location for a crane should be carefully selected to provide a maximum working radius, and when two cranes are being used on the same site, mast heights and jib lengths shall be considered.

Cranes should typically be structured around two rails at their base between 4.5 m and 10 m apart with wheels in each corner. Cranes should not normally be tied down, so sufficient kentledge should be provided so as to ensure that vertical loading from the crane passes through the rails and into the foundation. The foundation shall be so designed that the unfactored loading from the crane and the unfactored pressure is less than the allowable bearing pressure of the soil.

Various foundation types can be selected depending on the ground conditions. Where possible a structural fill can be compacted and used to support a crane with the load spreading through layers of track support at 45° in to the soil strata below. When loads from the crane increase, reinforced concrete foundations may be required. This can involve a series of reinforced concrete beams used to support line loads as a result of the crane loading.

When ground conditions are particularly poor, pile foundations may be necessary. The design shall ensure that reinforcement at the top of the pile top should not cause problems for positioning the mast base section of the crane.

Tower cranes shall embody all fundamental principles of design in accordance with the good practice [7(17)] so as to secure reliability and safety in operation. The particular requirements for controls for tower cranes and the arrangement of basic control used for positioning loads shall be in accordance with the good practice [7(18)].

7.4 Falsework

Falsework involves a temporary structure used to

support other permanent structures until they can support themselves. Falsework shall be designed and erected in accordance with the good practice [7(19)].

7.5 Formwork

Formwork is the term used for a temporary mould into which concrete is poured and formed. Traditional formwork is fabricated using timber, but it can also be constructed from steel, glass fiber reinforced plastics and other materials.

Timber formwork is normally constructed on site using timber and plywood. It is easy to produce, although it can be time consuming for larger structures. Re-usable plastic formwork is generally used for quick pours of concrete. The formwork is assembled either from interlocking panels or from a modular system and is used for relatively simple concrete structures. It is not as versatile as timber formwork due to the prefabrication requirements and is best suited for low-cost, repetitive structures such as mass housing schemes.

Stay-in-place structural formwork is generally assembled on site using prefabricated fibre-reinforced plastic. It is used for concrete columns and piers and stays in place, acting as permanent axial and shear reinforcement for the structural member. It also provides resistance to environmental damage to both the concrete and reinforcing bars. Proprietary systems are used to support vertical formwork while concrete cures, consisting of series of tubes and ties.

When selecting formwork the type of concrete and temperature of the pour are important considerations as they both effect the pressure exerted on the formwork. Striking of formwork shall be governed by Part 6 'Structural Design, Section 5 Concrete: Subsection 5A Plain and Reinforced Concrete' of the Code.

High quality workmanship and inspection are necessary to ensure a high standard of work including finish.

7.6 Trench Support

A trench is defined as an excavation when its length greatly exceeds its depth. Shallow trenches are usually considered to be less than 6 m deep and deep trenches have depth greater than 6 m. Depending on the dimensions of a trench, excavation can either be carried out by hand or by using a mechanical digger. Trenches are commonly required to allow services, pipelines or foundations to be laid.

Water ingress into the trench is often a major issue and ground water table locations and soil strata should be investigated before any extensive excavation takes

place. Over short periods of time, for relatively shallow depths most soil types will stand almost vertically without any problems. However, trenches other than those which are relatively shallow may require a trench support scheme. Traditionally, trenching involved using timber to support horizontal and vertical soil loads and this technique is still used today. Timber trenching is generally used for low risk, narrow trenches, shafts or headings. The timber solutions require good workmanship and are reasonably labour-intensive; however, they are versatile and the equipment required is easy to handle and transport.

Trench boxes are suitable for low-risk situations in stable, dry ground and can be placed in pre-excavated trenches or installed using the 'dig and push' technique. The system requires at least two struts at each panel for stability which should be considered when access is required for construction work or piping.

Trench sheets are the most adaptable of the systems available, and are most commonly used to retain poorer soil. They can support deeper trenches with larger surcharges and provide a continuous support. They require multiple levels of strut support and the slenderness of the sheets can often limit the depth of the trench as they are installed by light machinery and could buckle under large vertical loads.

While making deep excavation near an existing structure, it is necessary that the lateral force caused by the existing structure should be taken care of.

Trench supports shall be provided in accordance with the good practice [7(20)].

8 STORAGE, STACKING AND HANDLING PRACTICES

8.1 General

8.1.1 Planning and Storage Layout

8.1.1.1 For any site, there should be proper planning of the layout for stacking and storage of different materials, components and equipment with proper access and proper manoeuvrability of the vehicles carrying the material. While planning the layout, the requirements of various materials, components and equipment at different stages of construction shall be considered.

8.1.1.2 Materials shall be segregated as to kind, size and length and placed in neat, orderly piles that are safe against falling. If piles are high they shall be stepped back at suitable intervals in height. Piles of materials shall be arranged so as to allow a passageway of not less than 1 m width in between the piles or stacks for inspection or removal. All passageways shall be kept clear of dry vegetation.

8.1.1.3 Materials shall be stored, stacked and handled in such a manner as to prevent deterioration or intrusion of foreign matter and to ensure the preservation of their quality and fitness for the work.

8.1.1.4 Materials shall be stacked on well drained, firm and unyielding surface. Materials shall not be stacked so as to impose any undue stresses on walls or other structures.

8.1.1.5 Materials shall be stacked in such a manner as not to constitute a hazard to passerby. At such places the stacks shall have suitable warning signs in day time and red lights on and around them at night.

8.1.1.6 Stairways, passageways and gangways shall not become obstructed by storage of building materials, tools or accumulated rubbish.

8.1.2 Protection Against Atmospheric Agencies

Materials stored at site, depending upon the individual characteristics, shall be protected from atmospheric actions, such as rain, sun, winds and moisture, to avoid deterioration.

8.1.3 Protection Against Fire and Other Hazards

8.1.3.1 Materials, like timber, bamboo, coal, paints, etc, shall be stored in such a way that there may not be any possibility of fire hazards. Inflammable materials like kerosene and petrol, shall be stored in accordance with the relevant rules and regulations so as to ensure the desired safety during storage. Stacks shall not be piled so high as to make them unstable under fire fighting conditions and in general they shall not be more than 4.5 m in height. The provisions given in good practice [7(21)] shall be followed. Explosives like detonators shall be stored in accordance with the existing regulations of *The Explosives Act, 1884*.

8.1.3.2 Materials which are likely to be affected by subsidence of soil like precast beams, slabs and timber of sizes shall be stored by adopting suitable measures to ensure unyielding supports.

8.1.3.3 Materials liable to be affected by floods, tides, etc, shall be suitably stored to prevent their being washed away or damaged due to floods, tides, etc.

8.1.4 Manual Handling

When heavy materials have to be handled manually each workman shall be instructed by his foreman or supervisor for the proper method of handling such materials. Each workman shall be provided with suitable equipment for his personal safety as necessary. All workers shall wear adequate clothing to protect themselves from direct sun-rays and other irritants. Supervisors shall also take care to assign enough men to each such job depending on the weight and the distance involved.

8.2 Storage, Stacking and Handling of Materials

8.2.1 The storage, stacking and handling of materials generally used in construction shall be as given in **8.2.2** to **8.2.31**, which have been summarized in the form of a check list in Annex A. Exposure to asbestos fibres/dust is known to be harmful to health of human beings. Prescribed guidelines in accordance with good practice [7(22)] shall be followed for handling and usage of asbestos cement products.

8.2.2 Cement

a) *Storage and stacking* — Cement shall be stored at the work site in a building or a shed which is dry, leak-proof and as moisture-proof as possible. The building or shed for storage should have minimum number of windows and close fitting doors and these should be kept closed as far as possible.

Cement received in bags shall be kept in such a way that the bags are kept free from the possibility of any dampness or moisture coming in contact with them. Cement bags shall be stacked off the floor on wooden planks in such a way as to keep them about 150 mm to 200 mm clear above the floor. The floor may comprise lean cement concrete or two layers of dry bricks laid on a well consolidated earth. A space of 600 mm minimum shall be left around between the exterior walls and the stacks (*see* Fig. 3). In the stacks the cement bags shall be kept close together to reduce circulation of air as much as possible. Owing to pressure on bottom layer of bags sometimes 'warehouse pack' is developed in these bags. This can be removed easily by rolling the bags when cement is taken out for use. Lumped bags, if any should be removed and disposed of.

The height of stack shall not be more than 10 bags to prevent the possibility of lumping up under pressure. The width of the stack shall be not more than four bags length or 3 m. In stacks more than 8 bags high, the cement bags shall be arranged alternately length-wise and cross-wise so as to tie the stacks together and minimise the danger of toppling over. Cement bags shall be stacked in a manner to facilitate their removal and use in the order in which they are received; a table showing date of receipt of cement shall be put on each stack to know the age of cement.

For extra safety during monsoon, or when it is expected to store for an unusually long period, the stack shall be completely enclosed by a water proofing membrane such as polyethylene, which shall close on the top of the stack. Care shall be taken to see that the waterproofing membrane is not damaged any time during the use.

Cement in gunny bags, paper bags and polyethylene bags shall be stored separately.

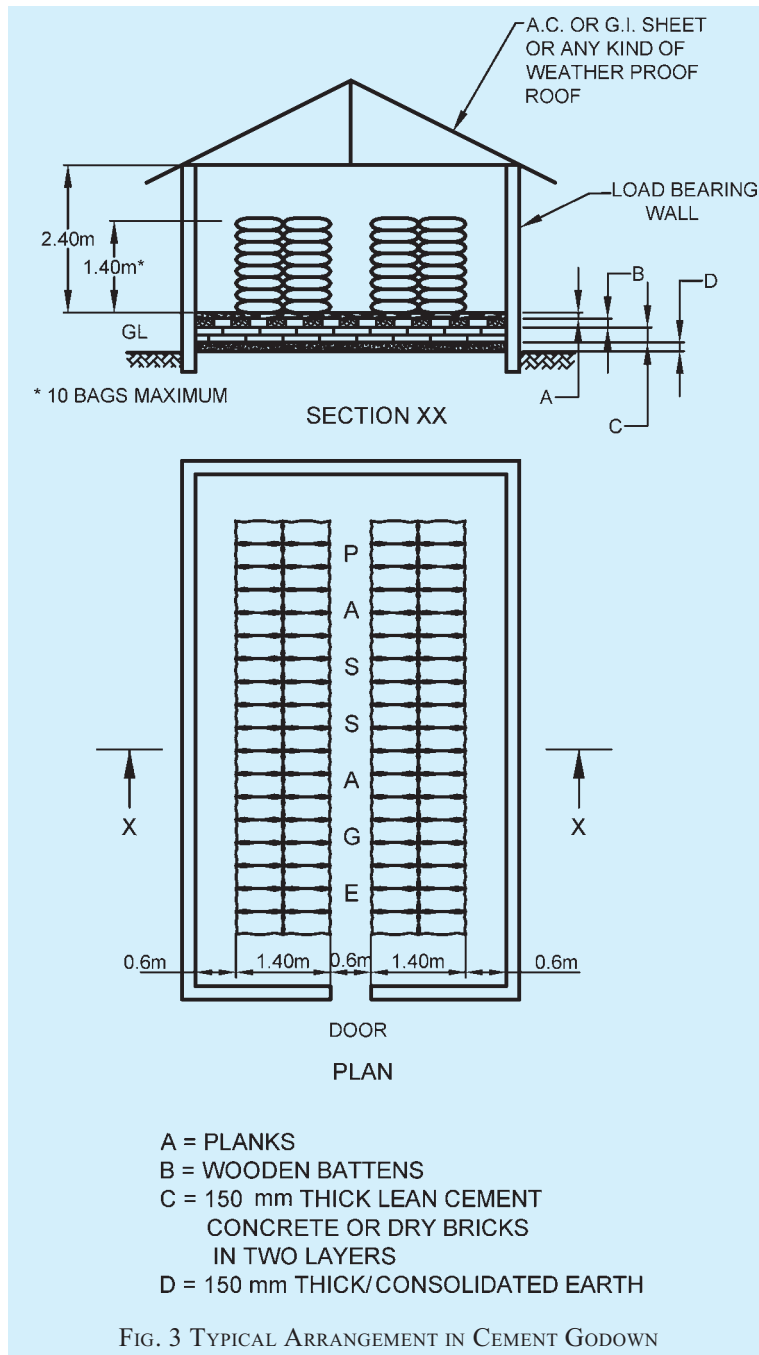

In case cement is received in drums, these shall be stored on plane level ground, as far as possible near the concrete mixing place. After taking out the required quantity of cement, the lid of the drum shall be securely tied to prevent ingress of moisture.

In case cement is received in silos, the silos shall be placed near the concrete batching plant. Proper access shall be provided for the replacement of silos.

Different types of cements shall be stacked and stored separately.

b) *Handling* — Hooks shall not be used for handling

cement bags unless specifically permitted by the engineer-in-charge. Bags shall be removed uniformly from the top of the piles to avoid tipping of the stack.

For information regarding bulk handling of cement (see 8.2.4).

8.2.3 Lime

8.2.3.1 Quicklime before slaking

- a) *Storage and stacking* — Quicklime should be slaked as soon as possible. If unavoidable it may be stored in compact heaps having only the minimum of exposed area. The heaps shall

be stored on a suitable platform and covered to avoid direct contact with rain or being blown away by wind. In case quick lime is stored in a covered shed, a minimum space of 300 mm should be provided all-round the heaps to avoid bulging of walls.

Unslaked lime shall be stored in a place inaccessible to water and because of fire hazards, shall be segregated from the combustible materials.

- b) *Handling* — See 8.2.4.

8.2.3.2 Hydrated lime

- a) *Storage and stacking* — Hydrated lime is generally supplied in containers, such as jute bags lined with polyethylene or craft paper bags. It should be stored in a building to protect the lime from dampness and to minimise warehouse deterioration.

The building should be with a concrete floor and having least ventilation to eliminate draughts through the walls and roof. In general, the recommendations given in 8.2.2 for storing of cement shall be applicable for hydrated lime. When air movement is reduced to a practical minimum, hydrated lime can be stored for up to three months without appreciable change.

- b) *Handling* — See 8.2.4.

8.2.3.3 Dry slaked lime

- a) *Storage and stacking* — The lime shall be stored in a dry and closed godown.

- b) *Handling* — See 8.2.4.

8.2.4 Handling of Cement and Lime

Workers, handling bulk cement or lime shall wear protective clothing, respirators, and goggles; shall be instructed in the need of cleanliness to prevent dermatitis, and shall be provided with hand cream, petroleum jelly, or similar preparation for protection of exposed skin. Workers handling cement, who are continually exposed to it, shall, in addition to the above be equipped with hand gloves and dust mask.

Bulk cement stored in silos or bins may fail to feed to the ejection system. When necessary to enter a silo or bin for any purpose, the ejection system employed shall be shut down and locked out electrically as well as mechanically. When necessary for a workman to enter such storage area, he shall wear a life-line, with another workman outside the silo or hopper attending the rope.

8.2.5 Masonry Units

- a) *Stones* — Stones of different sizes, types and

classification shall be stored separately. Stones shall be stacked on dry firm ground in a regular heap not more than 1 m in height. Veneering stones shall be stacked against vertical support on a firm dry ground in tiers, upto a height of 1.2 m. A distance of about 0.8 m shall be kept between two adjacent stacks.

- b) *Bricks* — Bricks shall be stacked in regular tiers as and when they are unloaded to minimise breakage and defacement. These shall not be dumped at site. In the case of bricks made from clays containing lime *Kankar*, the bricks in stack should be thoroughly soaked in water (docked) to prevent lime bursting.

Bricks shall be stacked on dry firm ground. For proper inspection of quality and ease in counting, the stacks shall be 50 bricks long, 10 bricks high and not more than 4 bricks in width, the bricks being placed on edge, two at a time along the width of the stack. Clear distance between adjacent stacks shall not be less than 0.8 m. Bricks of each truck load shall be put in one stack. Bricks of different types, such as, clay bricks, clay fly ash bricks, fly ash lime bricks, sand lime (calcium silicate) bricks shall be stacked separately. Bricks of different classifications from strength consideration and size consideration (such as, conventional and modular) shall be stacked separately. Also bricks of different types, such as, solid, hollow and perforated shall be stacked separately.

- c) *Blocks* — Blocks are available as hollow and solid concrete blocks, hollow and solid light weight concrete blocks, autoclaved aerated concrete blocks, concrete stone masonry blocks and soil based blocks. Blocks shall be unloaded one at a time and stacked in regular tiers to minimise breakage and defacement. These shall not be dumped at site. The height of the stack shall not be more than 1.2 m, the length of the stack shall not be more than 3.0 m, as far as possible and the width shall be of two or three blocks. Normally blocks cured for 28 days only should be received at site. In case blocks cured for less than 28 days are received, these shall be stacked separately. All blocks should be water cured for 10 to 14 days and air cured for another 15 days; thus no blocks with less than 28 days curing shall be used in building construction. Blocks shall be placed close to the site of work so that least effort is required for their transportation. The date of manufacture of the blocks shall be suitably marked on the stacks of blocks

manufactured at factory or site.

- d) *Handling* — Brick stacks shall be placed close to the site of work so that least effort is required to unload and transport the bricks again by loading on pallets or in barrows. Unloading of building bricks or handling in any other way likely to damage the corners or edges or other parts of bricks shall not be permitted.

8.2.6 Floors, Wall and Roof Tiles

- a) *Storage and stacking* — Floor, wall and clay roof tiles of different types, such as, cement concrete tiles (plain, coloured and terrazzo) and ceramic tiles (glazed and unglazed) shall be stacked on regular platform as far as possible under cover in proper layers and in tiers and they shall not be dumped in heaps. In the stack, the tiles shall be so placed that the mould surface of one faces that of another. Height of the stack shall not be more than one metre.

Tiles of different quality, size and thickness shall be stacked separately to facilitate easy removal for use in work. Tiles when supplied by manufacturers packed in wooden crates shall be stored in crates. The crates shall be opened one at a time as and when required for use.

- b) *Handling* — Ceramic tiles and roof tiles are generally supplied in cartons which shall be handled with care to avoid breakage. It is preferable to transport these at the site on platform trolleys.

8.2.7 Aggregate

- a) *Storage and stacking* — Aggregates shall be stored at site on a hard dry and level patch of ground. If such a surface is not available, a platform of planks or old corrugated iron sheets, or a floor of bricks, or a thin layer of lean concrete shall be made so as to prevent the mixing with clay, dust, vegetable and other foreign matter.

Stacks of fine and coarse aggregate shall be kept in separate stock piles sufficiently removed from each other to prevent the material at the edges of the piles from getting intermixed. On a large job it is desirable to construct dividing walls to give each type of aggregates its own compartment. Fine aggregates shall be stacked in a place where loss due to the effect of wind is minimum.

- b) *Handling* — When withdrawals are made from stock piles, no overhang shall be permitted.

Employees required to enter hoppers shall be equipped with safety belts and life-lines, attended by another person. Machine driven hoppers, feeders, and loaders shall be locked in the off position prior to entry, electrically as well as mechanically.

8.2.8 Pulverized Fuel Ash/Fly Ash/Silica

- a) *Storage and stacking* — Fly ash/Silica fume shall be stored in such a manner as to permit easy access for proper inspection and identification of each consignment. Fly ash in bulk quantities shall be stored in stack similar to fine aggregates, avoiding any intrusion of foreign matter. Fly ash in bags shall be stored in stacks not more than 10 bags high. Silica fume, in general, shall be stored similar to cement/fly ash storage depending upon the storage requirements in bags/bulk form.
- b) *Handling* — See 8.2.4.

8.2.9 Cinder

Cinder shall be stored in bulk quantities in stacks similar to coarse aggregates avoiding any extrusion of foreign matter.

8.2.10 Timber

- a) *Storage and stacking* — Timber shall be stored in stacks upon well treated and even surfaced beams, sleepers or brick pillars so as to be above the ground level by at least 150 mm to ensure that the timber will not be affected by accumulation of water under it. Various members shall preferably be stored separately in different lengths, and material of equal lengths shall be piled together in layers with wooden battens, called crossers, separating one layer from another. The crossers shall be of sound wood, straight and uniform in thickness. In case, where separate crossers are not available smaller sections of the available structural timber may be employed in their place. In any layer an air space of about 25 mm shall be provided between adjacent members. The longer pieces shall be placed in the bottom layers and shorter pieces in the top layers but one end of the stack shall be in true vertical alignment. The crossers in different layers shall be in vertical alignment. The most suitable width and height of a stack are recommended to be about 1.5 m and 2.0 m. Distance between adjacent stacks is recommended to be at least 450 mm. In case the stacking with the help of battens is not possible, the timber may be close piled in heaps on raised foundations with the

precautions specified above.

The stacks shall be protected from hot dry winds or direct sun and rain. Heavy weights, such as metal rails or large sections of wood, are recommended to be placed on the top of the stack to prevent distortion or warping of the timber in the stack. In case timber is to be stored for about a year or more, to prevent end-cracking in the material, the ends of all members shall be coated with coal tar, aluminium leaf paints (hardened gloss oil), microcrystalline wax or any other suitable material.

- b) Care must be taken that handler or workers are not injured by rails, straps, etc, attached to the used timber. This applies particularly to planks and formwork for shuttering.

8.2.11 *Bamboo*

8.2.11.1 The site shall be properly inspected and termite colonies or mounds, if detected, shall be destroyed.

All refuse and useless cellulosic materials shall be removed from the site. The ground may then be disinfected by suitable insecticides. The area should have good drainage.

8.2.11.2 Bamboo may preferably be stacked on high skids or raised platform at least 300 mm above ground. Storage under cover reduces the liability to fungal attack. Good ventilation and frequent inspection are important.

8.2.11.3 Bamboo dries by air-seasoning under cover in the storage yards from 6 to 12 weeks' time.

8.2.11.4 Prophylactic treatment of bamboo during storage prevents losses due to fungi and insects even under open storage. Following chemicals have been found suitable at a coverage rate of 24 litre per tonne:

- a) Sodium pentachlorophenate : 1 percent solution.
- b) Boric acid + borax (1:1) : 2 percent solution.
- c) Sodium pentachlorophenate : 2.5 percent solution + boric acid + borax (5:1:1).

A mixture of these compounds yields the best results.

NOTE — For better protection of structural bamboo (if stored outside), repetition of the treatment after four to six months is desirable.

8.2.12 *Partially Prefabricated Wall and Roof Components*

- a) *Storage and stacking* — The wall components comprise blocks, sills, lintels, etc. The blocks shall be stacked in accordance with 8.2.5 (c). These shall be stacked on plane level ground having a floor of bricks or a thin layer of lean concrete.

The roof components such as precast RC joists, prefabricated brick panels, RC planks, channel units, cored units, waffle units, L-panel, single tee and double tee sections, ferrocement panels, etc shall be unloaded as individual components. These shall be stacked on plane level ground having a floor of bricks or a thin layer of lean concrete. RC planks, prefabricated brick panels and ferrocement panels shall be stacked against a brick masonry wall in slightly inclined position on both sides of the wall. Channel units, cored units and L-panels shall be stacked one over the other up to five tiers. The waffle units shall be stacked upside down as individual units. The RC joists, single tee and double tee sections shall be stacked as individual units one adjacent to the other. The distance between any two adjacent stacks shall not be less than 450 mm.

- b) *Handling* — The components shall be handled by holding the individual components at specified points so that the stresses due to handling are minimised.

8.2.13 *Steel*

- a) *Storage and stacking* — For each classification of steel, separate areas shall be earmarked. It is desirable that ends of bars and sections of each class be painted in distinct separate colours. Steel reinforcement shall be stored in a way as to prevent distortion and corrosion. It is desirable to coat reinforcement with cement wash before stacking to prevent scaling and rusting.

Bars of different classification, sizes and lengths shall be stored separately to facilitate issues in such sizes and lengths as to minimise wastage in cut from standard lengths.

In case of long storage or in coastal areas, reinforcement bars shall be stacked above ground level by at least 150 mm and a coat of cement wash shall be given to prevent scaling and rusting.

Structural steel of different sections, sizes and lengths shall be stored separately. It shall be stored above ground level by at least 150 mm upon platforms, skids or any other suitable supports to avoid distortion of sections. In case of coastal areas or in case of long storage, suitable protective coating of cement wash shall be given to prevent scaling and rusting.

- b) *Handling* — Tag lines shall be used to control the load in handling reinforcements or structural steel when a crane is employed.

Heavy steel sections and bundles shall be lifted and carried with the help of slings and tackles and shall not be carried on the shoulders of the workers.

8.2.14 Aluminium Sections

- a) *Storage and stacking* — Aluminium sections of different classification, sizes and lengths shall be stored separately, on a level platform under cover.
- b) *Handling* — The aluminium sections shall not be pulled or pushed from the stack nor shall be slid over each other, to protect the anodizing layer.

8.2.15 Doors, Windows and Ventilators

- a) *Storage and stacking* — Metal and plastic doors, windows and ventilators shall be stacked upright (on their sills) on level ground preferably on wooden battens and shall not come in contact with dirt or ashes. If received in crates they shall be stacked according to manufacturer's instructions and removed from the crates as and when required for the work. Metal and plastic frames of doors, windows and ventilators shall be stacked upside down with the kick plates at the top. These shall not be allowed to stand for long in this manner before being fixed so as to avoid the door frames getting out of shape and hinges being strained and shutters drooping.

During the period of storage of aluminium doors, windows and ventilators, these shall be protected from loose cement and mortar by suitable covering, such as tarpaulin. The tarpaulin shall be hung loosely on temporary framing to permit circulation of air to prevent moisture condensation.

All timber and other lignocellulosic material based frames and shutters shall be stored in a dry and clean covered space away from any infestation and dampness. The storage shall preferably be in well-ventilated dry rooms. The storage shall preferably be in well-ventilated dry rooms. The frames shall be stacked one over the other in vertical stacks with cross battens at regular distances to keep the stack vertical and straight. These cross battens should be of uniform thickness and placed vertically one above the other. The door shutters shall be stacked in the form of clean vertical stacks one over the other and at least 80 mm above ground on pallets or suitable beams or rafters. The top of the stack shall be

covered by a protecting cover and weighted down by means of scantlings or other suitable weights. The shutter stack shall rest on hard and level surface.

If any timber or other lignocellulosic material based frame or shutter becomes wet during transit, it shall be kept separate from the undamaged material. The wet material may be dried by stacking in shade with battens in between adjacent boards with free access of dry air. Separate stacks shall be built up for each size, each grade and each type of material. When materials of different sizes, grades and types are to be stacked in one stack due to shortage of space, the bigger size shall be stacked in the lower portion of the stacks. Suitable pallets or separating battens shall be kept in between the two types of material.

Precast concrete door and window frames shall be stored in upright position adopting suitable measures against risk of subsidence of soil/support.

- b) *Handling* — While unloading, shifting, handling and stacking timber or other lignocellulosic material based, metal and plastic door and window frames and shutters, care shall be taken that the pieces are not dragged one over the other as it may cause damage to their surface particularly in case of the decorative shutters. The pieces should be lifted and carried preferably flat avoiding damage to corners or sides.

8.2.16 Roofing Materials

8.2.16.1 Roofing sheets shall be stored and stacked in such a manner as not to damage them in any way.

8.2.16.2 Asbestos cement sheet

- a) *Storage and stacking* — Asbestos cement sheets shall be stacked horizontally to a height of not more than 1 m on a firm and level ground, with timber or other packing beneath them. If stacked in exposed position, they shall be protected from damage by wind. Asbestos cement sheets of same variety and size shall be stacked together. Damaged sheets shall not be stacked with sound materials. All damaged sheets shall be salvaged as early as possible.
- b) *Handling* — Not more than two sheets shall be first pushed forward along the valley line say about one fourth of the sheet length and preferably carried by two workers. Asbestos cement sheets shall be lowered or raised gently and not thrown.

8.2.16.3 Corrugated galvanized iron sheets and aluminium sheets

- a) *Storage and stacking* — Corrugated galvanized iron sheets and aluminium sheets shall be stacked horizontally to a height of not more than 0.5 m on a firm and level ground, with timber or other packing beneath them. To protect them from dust and rain water, these shall be covered with tarpaulin or polyethylene sheets.
- b) *Handling* — In bulk handling of CGI sheets, workers shall be provided with suitable hand protection.

8.2.16.4 Plastic sheets and glass reinforced plastic (GRP) sheets

- a) *Storage and stacking* — Plastic sheets and glass reinforced plastic (GRP) sheets shall be stacked under a shed to a height of not more than 0.5 m on a firm and level ground with timber or other packing beneath them.
- b) *Handling* — Handling shall be done to avoid any damage to the sheets.

8.2.17 Boards

8.2.17.1 Gypsum boards

- a) *Storage and stacking* — Gypsum boards shall be stored flat in a covered clean and dry place.
- b) *Handling* — See 8.2.17.2 (b).

8.2.17.2 Plywood, fibre board, particle board, block board, etc

- a) *Storage and stacking* — Plywood, fibre board, particle board, block board, etc, shall not be stored in the open and exposed to direct sun and rain. The boards shall be stacked on a flat dunnage, on the top of which a wooden frame shall be constructed with battens of 50 mm × 25 mm (*Min*) in such a way that it supports all four edges and corners of the boards with intermediate battens placed at suitable intervals to avoid warping. If required, the stack shall be adequately raised above ground level to ensure that it will not be affected by accumulation of water under it.
The board shall be stacked in a solid block in a clear vertical alignment. The top sheet of each stack shall be suitably weighed down to prevent warping, wherever necessary.
- b) *Handling* — The board shall be unloaded and stacked with utmost care avoiding damage to the corners and surface. In case of decorative plywood and decorative boards, the surfaces

of which are likely to get damaged by dragging one sheet over another, it is advisable that these are lifted as far as possible in pairs facing each other.

8.2.18 Plastic and Rubber Flooring Sheets and Tiles

- a) *Storage and stacking* — Plastic and rubber sheets have tendency to break-down during storage. Plastic and rubber sheets shall be stored according to manufacturer's instructions.

The coolest store room available shall be utilized for the storage of the sheets. The store rooms where the sheets are stored shall be well ventilated and direct light should not be allowed to fall on them.

The sheets shall be stored away from electric generators, electric motors, switchgears and other such electrical equipment as they produce harmful odour/gases.

Contamination of the sheets with vegetable and mineral oils; greases; organic solvents; acids and their fumes; alkalies; dust and grit shall be prevented. Where greasy contamination occurs, this shall be removed immediately with petrol and the sheets and tiles thoroughly wiped dry and dusted with chalk.

Undue stretch and strain, kinks, sharp bends or folds of the sheets and tiles shall be avoided. In case of long storage, the sheets shall be turned over periodically and treated with chalk powder, if necessary.

- b) *Handling* — While handling plastic and rubber sheets, workers shall lift the sheets and carry them flat to avoid sharp bends or folds of the sheets.

8.2.19 Glass Sheets

- a) *Storage and stacking* — The special glasses shall be stored and handled as per manufacturer's instructions. It is important that all glass sheets whether stored in crates or not shall be kept dry. Suitable covered storage space shall be provided for the safe storage of the glass sheets. The glass sheets shall be lifted and stored on their long edges and shall be put into stacks of not more than 25 panes, supported at two points by fillets of wood at about 300 mm from each end. The first pane laid in each stack shall be so placed that its bottom edge is about 25 mm from the base of the wall or other support against which the stack rests. The whole stack shall be as close and as upright as possible. To prevent

slipping on smooth floor, the floor shall be covered with gunny bags. The glass sheets of different sizes, thickness and type shall be stacked separately. The distance between any two stacks shall be of the order of 400 mm.

- b) *Handling* — Workers handling glass panes, waste glass pieces and fibre glass shall be provided with suitable hand protection. In removing glass sheets from crates, due care shall be taken to avoid damages. Glass edges shall be covered or otherwise protected to prevent injuries to workers. Special glasses shall be stored and handled as per manufacturer's instructions.

8.2.20 Cast Iron, Galvanized Iron and Asbestos Cement Pipes and Fittings

- a) *Storage and stacking* — The pipes shall be unloaded where they are required, when the trenches are ready to receive them.

Storage shall be provided at the bottom layer to keep the stack stable. The stack shall be in pyramid shape or the pipes placed lengthwise and crosswise in alternate layers. The pyramid stack is advisable in smaller diameter pipes for conserving space in storing them. The height of the stack shall not exceed 1.5 m.

Each stack shall contain only pipes of same class and size, with consignment or batch number marked on it with particulars or suppliers wherever possible.

Cast iron detachable joints and fittings shall be stacked under cover and separated from the asbestos cement pipes and fittings.

Rubber rings shall be kept clean, away from grease, oil, heat and light.

- b) *Handling* — Pipes in the top layer shall be handled first. At a time only one pipe shall be handled by two labourers while carrying to the actual site and shall be carried on shoulders. Fittings shall be handled individually.

8.2.21 Polyethylene Pipes

- a) *Storage and stacking* — Black polyethylene pipes may be stored either under cover or in the open. Natural polyethylene pipes, however, should be stored under cover and protected from direct sunlight.

Coils may be stored either on edge or stacked flat one on top of the other, but in either case they should not be allowed to come into contact with hot water or steam pipes and should be kept away from hot surface.

Straight lengths should be stored on horizontal

racks giving continuous support to prevent the pipe taking on a permanent set. Storage of pipes in heated areas exceeding 27°C should be avoided.

- b) *Handling* — Removal of pipe from a pile shall be accomplished by working from the ends of the pipe.

8.2.22 Unplasticized PVC Pipes

- a) *Storage and stacking* — Pipes should be stored on a reasonably flat surface free from stones and sharp projections so that the pipe is supported throughout its length. The pipe should be given adequate support at all times. In storage, pipe racks should be avoided. Pipe should not be stacked in large piles especially under warm temperature conditions as the bottom pipes may distort thus giving rise to difficulty in jointing. Socket and spigot pipes should be stacked in layers with sockets placed at alternate ends of the stacks to avoid lopsided stacks.

It is recommended not to store a pipe inside another pipe. On no account should pipes be stored in a stressed or bend condition or near a source of heat. Pipes should not be stacked more than 1.5 m high. Pipes of different sizes and classes should be stacked separately.

In tropical conditions, pipes should be stored in shade. In very cold weather, the impact strength of PVC is reduced making it brittle.

The ends of pipe should be protected from abrasion particularly those specially prepared for jointing either spigot or socket solvent welded joints or soldered for use with couplings.

If due to unsatisfactory storage or handling, a pipe becomes kinked, the damaged portion should be cut out completely. Kinking is likely to occur only on very thin walled pipes.

- b) *Handling* — Great care shall be exercised in handling these pipes in wintry conditions as these become brittle in very cold weather.

8.2.23 Pipes of Conducting Materials

- a) *Storage and stacking* — Pipes shall be stacked on solid level sills and contained in a manner to prevent spreading or rolling of the pipe. Where quantity storage is necessary, suitable packing shall be placed between succeeding layers to reduce the pressure and resulting spreading of the pile.

In stacking and handling of pipes and other conducting materials, the following minimum safety distances shall be ensured from the

overhead power lines:

- 1) 11 kV and below : 1.40 m
 - 2) Above 11 and below 33 kV : 3.60 m
 - 3) Above 33 and below 132 kV : 4.70 m
 - 4) Above 132 and below 275 kV : 5.70 m
 - 5) Above 275 and below 400 kV : 6.50 m
- b) *Handling* — Removal of pipes from a pile shall be accomplished by working from the ends of the pipe. During transportation, the pipes shall be so secured as to ensure against displacement.

8.2.24 Piles and Poles

- a) *Storage and stacking* — Piles and poles shall be carefully stacked on solid, level sills so as to prevent rolling or spreading of the pile. The storage area shall be maintained free of vegetation and flammable materials.
- b) *Handling* — When placing piles or poles on the stack, workers shall work from the ends of the piles/poles. Similar precautions shall be observed in removal of piles/poles from the stack. Tag lines shall be used to control piles and poles when handling for any purpose.

In stacking and handling of piles and poles, precautions as laid down in 8.2.18 (a) shall be followed.

8.2.25 Paints, Varnishes and Thinners

- a) *Storage and stacking* — Paints, varnishes, lacquers, thinners and other flammable materials shall be kept in properly sealed or closed containers. The containers shall be kept in a well ventilated location, free from excessive heat, smoke, sparks or flame. The floor of the paint stores shall be made up of 100 mm thick loose sand.

Paint materials in quantities other than required for daily use shall be kept stocked under regular storage place.

Where the paint is likely to deteriorate with age, the manner of storage shall facilitate removal and use of lots in the same order in which they are received.

Temporary electrical wirings/fittings shall not be installed in the paint store. When electric lights, switches or electrical equipment are necessary, they shall be of explosion proof design.

- b) *Handling* — Adequate ventilation to prevent the accumulation of flammable vapours to hazardous levels of concentration shall be provided in all areas where painting is done.

When painting is done in confined spaces where flammable or explosive vapours may develop, any necessary heat shall be provided through duct work remote from the source of flame.

Sources of ignition, such as open flame and exposed heating elements, shall not be permitted in area or rooms where spray painting is done nor shall smoking be allowed there.

Care should be taken not to use any naked flame inside the paint store. Buckets containing sand shall be kept ready for use in case of fire. Fire extinguishers when required shall be of foam type conforming to accepted standards [7(23)] {see also good practice [7(24)]}.

Each workman handling lead based paints shall be issued ½ litre milk per day for his personal consumption.

8.2.26 Bitumen, Road Tar, Asphalt, etc

- a) *Storage and stacking* – Drums or containers containing all types of bitumen, road tar, asphalt, etc, shall be stacked vertically on their bottoms in up to 3 tiers. Leaky drums shall be segregated. Empty drums shall be stored in pyramidal stacks neatly in rows.
- b) *Handling* — See 9.13.3.1.2 and 9.13.3.4.

8.2.27 Bituminous Roofing Felts

- a) *Storage and stacking* — Bituminous roofing felts shall be stored away from other combustible materials and shall be kept under shade.
- b) *Handling* — Bituminous roofing felts should be handled in a manner to prevent cracking and other damages.

8.2.28 Flammable Materials

- a) *Storage and stacking* — In addition to the requirements as laid down in 8.1.3, the following provisions shall also apply:
- 1) Outdoor storage of drums requires some care to avoid contamination because moisture and dirt in hydraulic brake and transmission fluid, gasoline, or lubricants may cause malfunction or failure of equipment, with possible danger to personnel. The storage area should be free of accumulations of spilled products, debris and other hazards.
 - 2) Compressed gases and petroleum products shall not be stored in the same building or close to each other. Storage of petroleum products should be as per *Petroleum Rules, 2002*, as amended from time-to-time.

- b) *Handling* — Petroleum products delivered to the job site and stored there in drums shall be protected during handling to prevent loss of identification through damage to drum markings, tags, etc. Unidentifiable petroleum products may result in improper use, with possible fire hazard, damage to equipment or operating failure.

Workers shall be required to guard carefully against any part of their clothing becoming contaminated with flammable fluids. They shall not be allowed to continue work when their clothing becomes so contaminated.

8.2.29 *Water*

Water to be stored for construction purposes shall be stored in proper tanks to prevent any ingress of organic impurities. The aggregate capacity of storage tanks shall be determined after taking into account the requirements of firefighting.

8.2.30 *Sanitary Appliances*

- a) *Storage and stacking* — All sanitary appliances shall be carefully stored under cover to prevent damage. When accepting and storing appliances, consideration shall be given to the sequence of removal from the store to the assembly positions. Vitreous fittings shall be stacked separately from the metal ones.
- b) *Handling* — Bigger sanitary appliances shall be handled one at a time. Traps, water seals and gullies shall be handled separately. While handling sanitary fittings they shall be free from any oil spilling, etc. The hands of the workers shall also be free from any oily substance. Before lowering the appliances in their position the supporting brackets, pedestals, etc, shall be checked for their soundness and then only the fixtures be attached.

8.2.31 *Other Materials*

Polymeric materials such as coatings, sheeting, reflective surfacing/sheeting, etc, shall be stored as per the manufacturers' instructions. Special precautions shall be taken in case of storage, handling and usage of toxic materials.

Small articles like screws, bolts, nuts, door and window fittings, polishing stones, protective clothing, spare parts of machinery, linings, packings, water supply and sanitary fittings, and electrical fittings, insulation board, etc, shall be kept in suitable and properly protected containers or store rooms. Valuable small materials shall be kept under lock and key.

8.2.32 *Special Considerations*

8.2.32.1 Materials constantly in use shall be relatively nearer to the place of use.

8.2.32.2 Heavy units like precast concrete members shall be stacked near the hoist or the ramp.

8.2.32.3 Materials which normally deteriorate during storage shall be kept constantly moving, by replacing old materials with fresh stocks. Freshly arrived materials shall never be placed over materials which had arrived earlier.

8.2.32.4 Appropriate types of fire extinguishers shall be provided at open sites where combustible materials are stored and for each storage shed/room where flammable/combustible materials are stored. For guidance regarding selection of the appropriate types of fire extinguishers reference may be made to good practice [7(24)]. It is desirable that a minimum of two extinguishers are provided at each such location.

8.2.32.5 Workers handling excavated earth from foundation, particularly if the site happens to be reclaimed area or marshy area or any other infected area, shall be protected against infection affecting their exposed body portions.

8.2.32.6 *House keeping*

Stairways, walkways, scaffolds, and access ways shall be kept free of materials, debris and obstructions. The engineer-in-charge/the foreman shall initiate and carry out a programme requiring routine removal of scrap and debris from scaffolds and walkways.

8.2.32.7 Where stacking of the materials is to be done on road side berms in the street and other public place, the owner shall seek permission from the Authority for such stacking and also for removing the remnants of the same after the construction is over, so as to avoid any hazard to the public.

8.3 *Unloading Rail/Road Wagons and Motor Vehicles*

8.3.1 *Loading and unloading from rail/road wagons*

8.3.1.1 Appropriate warning signals shall be displayed to indicate that the wagons shall not be coupled or moved.

8.3.1.2 The wheels of wagons shall always be sprigged or chained while the wagons are being unloaded. The brakes alone shall not be depended upon.

8.3.1.3 Special level bars shall preferably be used for moving rail wagons rather than ordinary crow bars.

8.3.1.4 Where gangplanks are used between wagons and platforms of piles (heaps), cleats at lower end of

gangplank, or pin through end of gangplanks, shall be used to prevent sliding. If gangplank is on a gradient, cleats or abrasive surface shall be provided for the entire length.

8.3.1.5 When rail/road wagons are being loaded or unloaded near passageways or walkways, adequate warning signals shall be placed on each end of the wagon to warn pedestrians.

8.3.2 Loading and Unloading from Motor Vehicles

8.3.2.1 The motor vehicles shall be properly blocked while being loaded or unloaded; brakes alone shall not be depended upon to hold them.

8.3.2.2 When motor vehicles are being loaded or unloaded near passageways or walkways, adequate warning signs shall be placed on each end of the vehicle to warn the pedestrians.

8.3.2.3 Adequate lighting shall be provided while loading/unloading.

8.3.3 Handling Heavy/Long Items

8.3.3.1 Loading and unloading of heavy items, shall, as far as possible, be done with cranes or gantries. The workman shall stand clear of the material being moved by mechanical equipment. The slings and the ropes used shall be of adequate load carrying capacity, so as not to give way and result in accidents.

8.3.3.2 While heavy and long components are being manually loaded into motor vehicle, wagons, trailer, etc, either wooden sleepers or steel rails of sufficient length and properly secured in position shall be put in a gentle slope against the body of the wagon/vehicle at 3 or 4 places for loading. These long items shall be dragged, one by one, gently and uniformly along these supports by means of ropes, being pulled by men with feet properly anchored against firm surface. As soon as the items come on the floor of the vehicle, the same may be shifted by crowbars and other suitable leverage mechanism, but not by hands to avoid causing accident to the workers.

8.3.3.3 Similar procedure as outlined under **8.3.3.2** shall be followed for manual unloading of long or heavy items.

SECTION 4 SAFETY IN CONSTRUCTION

9 SAFETY IN CONSTRUCTION OF ELEMENTS OF A BUILDING

9.1 General

9.1.1 The provisions of this section shall apply to the erection/alteration of the various parts of a building or similar structure. The construction of the different elements shall conform to **6.4**.

9.1.2 Other Laws

Nothing herein stated shall be construed to nullify any rules, regulations, safety standards or statutes of the local state governments or those contained in the various Acts of the Government of India. The specific rules, regulations and acts pertaining to the protection of the public or workers from health and other hazards, wherever specified by the Local/State Authority or in the Acts of the Government take precedence over whatever is herein specified in case of a doubt or dispute.

9.1.3 Safety Management

9.1.3.1 The safety of personnel engaged in building construction should be ensured through a well planned and well organized mechanism by employing the guidelines given in good practice [7(12)].

9.1.3.2 Notwithstanding the guidelines given in **9.1.3.1**, all provisions given in relevant Act/Rules/Regulations as amended from time to time shall be followed; in this regard, reference shall also be made to the *Building and other Construction Workers (Regulation of Employment and Conditions of Service) Act, 1996* and the rules/regulations framed thereunder.

9.2 Temporary Construction, Use of Side Walls and Temporary Encroachments

9.2.1 Temporary Construction

The plans and specifications of temporary constructions, which are likely to interfere with facilities or right of way provided by the Authority, shall be submitted to the Authority for approval showing clearly the layout, design and construction.

9.2.1.1 Temporary structure referred to in **9.2.1** shall apply to the following types of structures :

- a) Structures with roof or walls made of straw, hay, ulugrass, golpatta, hogle, darma, mat, canvas cloth or other like materials not adopted for permanent or continuous occupancy.
- b) Site-work sheds, truck-runways, trestles, foot-bridges, etc.

9.2.2 For detailed information regarding fire safety aspects in respect of construction, location, maintenance and use of temporary structures [mentioned in **9.2.1.1(a)**] including pandals used by public for outdoor assembly, reference may be made to good practice [7(25)].

9.2.3 Special permits shall be obtained for the storage of the materials on side walks and highways. It shall be ensured that the material dump or the storage shed does not create a traffic hazard, nor it shall interfere with the free flow of the pedestrian traffic. Special permits

shall also be obtained for the use of water and electricity from the public facilities. Whenever such utilities are made use of, adequate safety precautions regarding drainage and elimination of contamination and hazards from electricity shall be taken.

9.2.4 In order to ensure safety for the adjoining property, adequate temporary protective guards are to be provided. In case these protective devices project beyond the property, the consent of the Authority and that of the owner of the adjoining property shall be obtained.

9.3 Testing

9.3.1 Tests

No structure, temporary support, scaffolding or any construction equipment during the construction or demolition of any building or structure shall be loaded beyond the allowable loads and working stresses as provided for in Part 6 'Structural Design' of the Code {see also good practices [7(26)]}.

9.3.1.1 Whenever any doubt arises about the structural adequacy of a scaffolding, support or any other construction equipment, it shall be tested to two and a half times the superimposed dead and imposed loads to which the material or the equipment is subjected to and the member/material shall sustain the test load without failure if it is to be accepted.

9.3.2 Notwithstanding the test mentioned above, if any distress in any member is visible, the member shall be rejected.

9.4 Inspection and Rectification of Hazardous Defects

9.4.1 Inspection

The Authority shall inspect the construction equipment and if during the inspection, it is revealed that unsafe/illegal conditions exist, the Authority shall intimate the owner and direct him to take immediate remedial measures to remove the hazard/violation.

9.4.2 Rectification

The owner shall proceed to rectify the defect, hazardous condition or violation within 24 h of the receipt of the notice from the Authority. The Authority shall have full powers to rectify the unsafe condition and all expenses incurred in this connection is payable by the owner of the property. Illegal encroachments and non-payment of money due, in respect of the rectification of unsafe conditions may vest a lien on the property with the Authority (see also Part 2 'Administration' of the Code).

9.4.3 When the strength and adequacy of any scaffold

or other construction equipment is in doubt or when any complaint is made, the Authority shall get the same inspected before use.

9.5 Foundations

9.5.1 General

The distribution of the supporting foundation shall be such as to avoid any harmful differential settlement of the structure. The type and design of the foundation adopted shall ensure safety to workers during construction and residents of the neighbouring property. Sufficient care shall be taken in areas, where withdrawal of ground water from surrounding areas could result in damages to such foundations. During the construction of the foundation, it shall be ensured that the adjoining properties are not affected by any harmful effects.

9.5.2 Adjoining Properties

The person causing excavation shall, before starting the work, give adequate notices in writing to the owner of the adjoining properties, safety of which is likely to be affected due to excavation. After having given such notices, wherein details regarding the type of protective works that are anticipated to be incorporated in the excavation are shown, written permission shall be obtained for such excavation from the adjoining property owners. Where necessary, the person causing excavation shall make adequate provision to protect the safety of adjacent property. If on giving such notices and the precautionary measures having been approved by the Authority, the adjoining property owner still refuses to give necessary facilities to the person causing excavation for protecting/providing both temporary and permanent supports to such property, the responsibility for any damage to the adjoining property shall be that of the adjoining property owner. The person causing excavation shall be absolved of responsibility for any loss of property or life in the adjoining property.

9.5.2.1 Protection to neighbouring structures and adjoining services

In driven piles, vibration is set up which may cause damage to adjoining structures or service lines depending on the nature of soil condition and the construction standard of such structures and service lines. Possible extent of all such damages shall be ascertained in advance and operation and mode of driving shall be planned with appropriate measures to ensure safety.

Wherever in the vicinity of a site where bored or driven piling works are to be carried out there are old structures which are likely to be damaged, tell-tales shall be fixed on such structures to watch their behaviour and timely precautions taken against any undesirable effect.

In case of bored piles, measures shall be taken to ensure,

that there is no appreciable movement of soil mass into the borehole which may cause subsidence to any existing foundation in the close proximity. In wet holes where such possibilities are likely to be there the same shall be minimised by approved technique and the operation should be planned.

9.5.3 During construction, inspection shall be made by the engineer-in-charge to ensure that all protective works carried out to safe-guard the adjoining property are sufficient and in good order to ensure safety (see Part 2 'Administration' of the Code).

9.5.4 Before carrying out any excavation work/pile driving, the position, depth and size of underground structures, such as water pipes, mains, cables or other services in the vicinity to the proposed work, may be obtained from the Authority to prevent accidents to workers engaged in excavation work and calamities for the general public.

Prior to commencement of excavation detailed data of the type of soils that are likely to be met with during excavation shall be obtained and the type of protective works by way of shoring timbering, etc, shall be decided upon for the various strata that are likely to be encountered during excavation. For detailed information regarding safety requirements during excavation reference may be made to good practice [7(20)].

9.6 General Requirements and Common Hazards During Excavation

9.6.1 Location of Machinery and Tools

Excavating machinery consisting of both heavy and light types shall be kept back from the excavation site at a distance which would be safe for such type of equipment. Heavy equipment, such as excavating machinery and road traffic shall be kept back from the excavated sites at a distance of not less than the depth of trench or at least 6 m for trench deeper than 6 m. Care shall also be taken to keep excavating tools and materials far away from the edge of trench to prevent such items being inadvertently knocked into the trench.

9.6.2 Excavated Materials

Excavated materials shall be kept back from the edges of the trench to provide clear berm of safe width. Where this is not feasible, the protective works designed for the trenches shall take into consideration, the additional load due to overburden of materials.

9.6.2.1 Other surcharges

Proximity of buildings, piles of lumber, crushed rocks, sand and other construction materials, large trees, etc, may impose surcharges on the side of the trench to cause sliding, etc. Under these conditions additional protective works shall be provided to support the sides of the trench.

9.6.3 Type of Strata

Adequate precautions, depending upon the type of strata met with during excavation (like quick sand, loose fills and loose boulder) shall be taken to protect the workers during excavation. Effect of climatic variations and moisture content variations on the materials under excavation shall be constantly watched and precautions taken, where necessary, immediately to prevent accidents at work site.

9.6.4 Overhang and Slopes

During any excavation, sufficient slopes to excavated sides by way of provision of steps or gradual slopes shall be provided to ensure the safety of men and machine working in the area.

9.6.5 Blasting for foundation of building is prohibited unless special permission is obtained from the Authority. Where blasting technique has to be resorted to, prior inspection for the stability of slopes shall be carried out. After blasting, overhangs or loose boulders shall be cleared by expert workers carrying out blasting prior to continuation of the excavation by normal working parties.

9.6.5.1 Burrowing or mining or what is known as 'gophering' shall not be allowed. In any trench where such methods have been followed, the cavities felt shall be eliminated by cutting back the bare slope before removing any further material from the section of the trench.

9.6.6 Health Hazards

Where gases or fumes are likely to be present in trenches, sufficient mechanical ventilation, to protect the health and safety of persons working there, shall be provided. If necessary, the personnel working there, shall be provided with respiratory protective equipment when work in such unhealthy conditions has to be carried out. The precautionary measures provided shall be inspected by the local health authorities prior to commencement of the work.

9.6.7 Safety of Materials

Materials required for excavation, like ropes, planks for gangways and walkways, ladders, etc, shall be inspected by the engineer-in-charge who shall ensure that no accident shall occur due to the failure of such materials (see Part 5 'Building Materials' of the Code).

9.6.8 Fencing and Warning Signals

Where excavation is going on, for the safety of public and the workers, fencing shall be erected, if there is likelihood of the public including cattle frequenting the area. Sufficient number of notice boards and danger sign lights shall be provided in the area to avoid any

member of public from inadvertently falling into the excavation. When excavations are being done on roads, diversion of the roads shall be provided with adequate notice board and lights indicating the diversion well ahead. Where necessary, recourse may be had for additional precautionary measures by way of watchmen to prevent accident to the general public, especially during hours of darkness.

9.6.9 Effect of Freezing and Thawing

Due to expansion of water when freezing, rock fragments, boulders, etc, are frequently loosened. Therefore, the side walls of the excavation shall be constantly watched for signs of cracks during a thaw. When depending in whole or in part on freezing to support the side walls, great care shall be taken during thaws to provide suitable bracing or remedy the condition by scaling of the loose material from the sides.

9.6.10 Vibrations from Nearby Sources

Vibration due to adjacent machinery, vehicles, railroads, blasting, piling and other sources require additional precautions to be taken.

9.6.11 Precautions While Using Petroleum Powered Equipment

At the site of excavation, where petroleum powered equipment is used, petroleum vapours are likely to accumulate at lower levels and may cause fire explosion under favourable circumstances. Care should, therefore, be taken to avoid all sources of ignition in such places.

9.7 Piling and Other Deep Foundations

9.7.1 General

9.7.1.1 Safety programme

All operations shall be carried out under the immediate charge of a properly qualified and competent foreman who shall also be responsible for the safety arrangements of the work.

9.7.1.2 For work during night, lighting of at least 100 lux intensity shall be provided at the work site.

9.7.1.3 Barricading/fencing shall be provided, wherever necessary, around the working area or the watchmen provided to prevent onlookers from trespassing into the construction sites. In case of digging a bore hole, precautions shall be taken that it is properly barricaded and is not left open to avoid accidental fall into the bore well.

9.7.1.4 The working area shall be investigated to ascertain the presence of any buried obstruction and actual position of all service lines passing through the work site shall be known before the work commences. Particular attention shall be given in case live electrical

cables pass underground, which may interfere within the depth of the foundation.

9.7.1.5 The safety provisions shall be brought to the notice of all concerned and matters needing special attention shall be displayed at a prominent place at the work spot.

9.7.1.6 All necessary personal protective equipment like full body harnesses, safety helmets and safety shoes, as considered suitable, shall be kept available for the use of persons employed on the site and maintained in condition suitable for immediate use.

9.7.1.7 A first-aid kit shall be maintained at the site near the place of work, to comply with the requirements and provisions for the work.

9.7.1.8 Those engaged in mixing and stacking of cement bags or any other material injurious to human body shall be provided with protective wear suitable for the purpose. Welders engaged in the work of welding shall use welding goggles/shields, helmets and gloves.

9.7.1.9 Every crane driver or hoisting appliance operator shall be competent to the satisfaction of the engineer-in-charge and no person under the age of 21 years should be in-charge of any hoisting machine including any scaffolding winch, or give signals to operator. Crane driver and hoisting appliance operator shall possess the knowledge of inherent risks involved in the operation of lifting appliances by undergoing a formal training at any institution of national importance acceptable to the employer and is medically examined periodically including in compliance to the requirement as may be specified in the *Building and other Construction Workers' (Regulation of Employment and Conditions of Service Central) Rules, 1998*.

9.7.1.10 Working in compressed air, in case of deep foundations, requires several precautions to be observed to safeguard the workers against severe hazards to life, compressed air disease and related ailments. For detailed information regarding safety requirements, reference may be made to good practice [7(27)].

9.7.2 Piling Rig

9.7.2.1 There are numerous types of piling rigs in piling work, depending on the need for the site conditions. While utilizing specialized rigs the instructions issued by the suppliers shall be kept in view.

9.7.2.1.1 Pile drivers shall not be erected in dangerous proximity to electric conductors.

9.7.2.1.2 If two pile drivers are erected at one place these shall be separated by a distance at least equal to the longest leg in either rig.

9.7.2.2 The frame of any rig shall be structurally safe

for all anticipated dead, live or wind loads. Whenever there is any doubt about the structural strength, suitable test shall be carried out by the foreman and the results of the test recorded. No pile-driving equipment shall be taken into use until it has been inspected and found to be safe.

9.7.2.3 Pile drivers shall be firmly supported on heavy timber sills, concrete beds or other secure foundation. If necessary, to prevent danger, pile drivers shall be adequately guyed.

When the rig is not in use, extra precautionary measures for stability, such as securing them with minimum four guys, shall be adopted to prevent any accidents due to wind, storm, gales and earthquake.

9.7.2.4 Access to working platforms and the top pulley shall be provided by ladders. Working platforms shall be protected against the weather.

9.7.2.4.1 In tall driven piling rigs or rigs of similar nature where a ladder is necessary for regular use, the ladder shall be securely fastened and extended for the full height of the rig. The ladder shall also be maintained in good condition at all times.

9.7.2.5 Exposed gears, fly wheels, etc, shall be fully enclosed. Boilers, hoisting drums and brakes shall be kept in good condition and sheltered from weather, wherever possible.

9.7.2.6 Pile driving equipment in use shall be inspected by a competent engineer at regular intervals not exceeding three months. Also a register shall be maintained at the site of work for recording the results of such inspections. Pile lines and pulley blocks shall be inspected by the foreman before the beginning of each shift for any excess wear or any other defect.

9.7.2.6.1 Defective parts of pile drivers, such as sheaves, mechanism slings and hose shall be repaired by only competent person and duly inspected by foreman-in-charge of the rig and the results recorded in the register. No steam or air equipment shall be repaired while it is in operation or under pressure. Hoisting ropes on pile drivers shall be made of galvanized steel.

9.7.2.7 All bolts and nuts which are likely to be loosened due to vibration during pile driving shall be checked regularly and tightened.

9.7.2.8 Steam and air lines shall be controlled by easily accessible shut-off valves. These lines shall consist of armoured hose or its equivalent. The hose of steam and air hammers shall be securely lashed to the hammer so as to prevent it from whipping if a connection breaks. Couplings of sections of hose shall be additionally secured by ropes or chains.

9.7.2.9 When not in use, the hammer shall be in dropped

position and shall be held in place by a cleat, timber or any other suitable means.

9.7.2.10 For every hoisting machine and for every chain ring hook, shackle, swivel and pulley block, used in hoisting or as means of suspension, the safe working loads shall be ascertained. In case of doubt actual testing shall be carried out and the working load shall be taken as half of the tested load. Every hoisting machine and all gears referred to above shall be plainly marked with the safe working load. In case of a hoisting machine having a variable safe working load, each safe working load together with the conditions under which it is applicable shall be clearly indicated. No part of any machine or any gear shall be loaded beyond the safe working load except for the purpose of testing.

All hoisting appliances should be fitted with automatic safe load indicator, boom angle indicator, swing alarm, back horn, over lift boom alarm. A register shall be maintained containing a system of identification of all tools and tackles, their date of purchase, safe working load and date of examination by competent person. All loads shall have tag-lines attached in order to ensure that the load can be controlled at all times.

9.7.2.11 Motor gearing, transmission, electrical wiring and other dangerous parts of hoisting appliances should be provided with efficient safeguards. Hoisting appliances shall be provided with such means as will reduce, to the minimum, the risk of accidental descent of the load and adequate precautions shall be taken to reduce to the minimum, the risk of any part of suspended load becoming accidentally displaced. When workers are employed on electrical installations which are already energized, insulating mats and wearing apparel, such as gloves, etc, as may be necessary, shall be provided. Sheaves on pile drivers shall be guarded so that workers may not be drawn into them.

When loads have to be inclined, they shall be adequately counter-balanced and the tilting device shall be secured against slipping.

9.7.2.12 Adequate precautions shall be taken to prevent a pile driver from overturning, if a wheel breaks.

9.7.2.13 Adequate precautions shall be taken by providing stirrups or by other effective means, to prevent the rope from coming out of the top pulley or wheel.

9.7.2.14 Adequate precautions shall be taken to prevent the hammer from missing the pile.

9.7.2.15 If necessary to prevent danger, long piles and heavy sheet piling should be secured against falling.

9.7.2.16 Wherever steam boilers are used, the safety regulations of boiler shall be strictly followed and safety

valves shall be adjusted to 0.07 N/mm² in excess of working pressure accurately.

9.7.2.17 Where electricity is used as power for piling rig, only armoured cable conforming to the relevant Indian Standard shall be used and the cable shall be thoroughly waterproofed.

9.7.3 Operation of Equipment

9.7.3.1 Workers employed in the vicinity of pile drivers shall wear helmets conforming to accepted standard [7(28)].

9.7.3.2 Piles shall be prepared at a distance at least equal to twice the length of the longest pile from the pile driver.

9.7.3.3 Piles being hoisted in the rig should be so slung that they do not have to be swung round, and may not inadvertently, swing or whip round. A hand rope shall be fastened to a pile that is being hoisted to control its movement. While a pile is being guided into position in the leads, workers shall not put their hands or arms between the pile and the inside guide or on top of the pile, but shall use a rope for guiding.

9.7.3.4 While a pile is being hoisted all workers not actually engaged in the operation shall keep at a distance which ensures safety. Piles shall not be slewed over public areas without stopping the pedestrians and road traffic first.

9.7.3.5 Before a wood pile is hoisted into position it shall be provided with an iron ring or cap over the driving end to prevent brooming.

9.7.3.6 When creosoted wood piles are being driven, adequate precautions shall be taken, such as the provision of personal protective equipment and barrier creams to prevent workers receiving eye or skin injuries from splashes of creosote.

9.7.3.7 When piles are driven at an inclination to the vertical, if necessary to prevent danger, these should rest in a guide.

9.7.3.8 No steam or air line shall be blown down until all workers are at a safe distance.

9.7.4 Sheet Piling

9.7.4.1 If necessary to prevent danger from wind or other sources, a hand rope shall be used to control the movement of steel sheet sections that are being transported.

9.7.4.2 Workers who have to sit on a steel sheet section to interlock sheets shall be provided with stirrups or other devices to afford them a safe seat. Workers shall not stand or sit on sheet piling while it is being released from the slings, lowered or moved into position.

9.7.4.3 Workers handling sheets should wear gloves.

9.7.4.4 If necessary to prevent danger from displacement by the current, steel sheet sections shall be braced until they are firmly in position. If necessary to prevent danger from undercutting of the cofferdam by the current a substantial berm shall be installed upstream.

9.7.4.5 Adequate pumping facilities shall be available at cofferdams to keep them clear of water. Also adequate means of escape, such as ladders and boats shall be provided at cofferdams for the protection of workers in case of flooding.

9.7.4.6 Adequate supplies of life-saving equipment shall be provided for workers employed on cofferdams.

9.7.4.7 When sheet sections are being removed, their movements shall be controlled by cables or other effective means.

9.8 Walls

9.8.1 General

Depending on the type of wall to be constructed the height of construction per day shall be restricted to ensure that the newly constructed wall does not come down due to lack of strength in the lower layers. Similarly, in long walls adequate expansion/crumple joints shall be provided to ensure safety.

9.8.2 Scaffold

Properly designed and constructed scaffolding built by competent workers shall be provided during the construction of the walls to ensure the safety of workers. The scaffolding may be of timber, metal or bamboo sections and the materials in scaffolding shall be inspected for soundness, strength, etc, at site by the engineer-in-charge prior to erection of scaffolds. Steel scaffolds intended for use in normal building construction work shall conform to accepted standard [7(29)]. Bamboo and timber scaffolds shall be properly tied to the junctions with coir ropes of sufficient strength or mechanical joints to ensure that joints do not give way due to the load of workers and material. Joining the members of scaffolds only with nails shall be prohibited as they are likely to get loose under normal weathering conditions. In the erection or maintenance of tall buildings, scaffoldings shall be of non-combustible material especially when the work is being done on any building in occupation. After initial construction of the scaffolding, frequent inspections of scaffolding shall be carried out regularly. The platforms, gangways and runways provided on the scaffoldings shall be of sufficient strength and width to ensure safe passage for the workers working on the scaffolding. The joints provided in these gangways, platforms, etc, shall be such as to ensure a firm foot-hold to the workers. Where necessary, cross bars shall be provided

to the full width of gangway or runway to facilitate safe walking. For detailed information regarding safety requirements for erection, use and dismantling of scaffolds, reference may be made to good practices [7(30)].

9.8.2.1 The engineer-in-charge shall ensure by frequent inspections that gangways of scaffolding have not become slippery due to spillage of material. Loose materials shall not be allowed to remain on the gangways. Where necessary, because of height or restricted width, hand-rails shall be provided on both sides. Workers shall not be allowed to work on the scaffolding during bad weather and high winds.

9.8.2.2 In the operations involved in the erection or maintenance of outside walls, fittings, etc, of tall buildings, it is desirable to use one or more net(s) for the safety of the workers when the workers are required to work on scaffoldings.

9.8.3 Ladders

All ladders shall be constructed of sound materials and shall be capable of carrying their intended loads safely. The ladders shall have not only adequate strength but rigidity as well. If a ladder shows tendency to spring, a brace shall be attached to its middle and supported from some other non-yielding fixed object. No ladder having a missing or defective rung or one which depends for its support solely on nails, shall be used. Ladders shall not be used as guys, braces or skids or for any other purpose for which they are not intended. They shall not be used in horizontal position as runways. They shall not be overcrowded. Wherever possible, ladders shall not be spliced. Where splicing is unavoidable, it shall be done only under the supervision of engineer-in-charge. Ladders leading to landings or walkways shall extend at least 1 m above the landing and shall be secured at the upper end. To prevent slipping, a ladder shall be secured at the bottom end. If this cannot be done, a person shall be stationed at the base whenever it is in use. As a further precaution, the pitch at which a lean-to-ladder is used shall be such that the horizontal distance of its foot from the vertical plane of its top shall be not more than one quarter of its length. If the surface of the floor on which the ladder rests is smooth or sloping, the ladder shall be provided with non-slip bases. If the use of a ladder is essential during strong winds, it shall be securely lashed in position. No ladder shall be placed or leant against window pane, sashes or such other unsafe or yielding objects, nor placed in front of doors opening towards it. If set up in driveways, passageways or public walkways, it shall be protected by suitable barricades. When ascending or descending, the user shall face the ladder, use both his hands and place his feet near the ends of the rungs rather than near the middle. It is dangerous to lean more than 30 cm

to side in order to reach a larger area from a single setting of the ladder. Instead, the user shall get down and shift the ladder to the required position.

Metal ladders shall not be used around electrical equipment or circuits of any kind where there is a possibility of coming in contact with the current. Metal ladders shall be marked with signs reading 'CAUTION—DO NOT USE NEAR ELECTRICAL EQUIPMENT'.

Wooden ladders shall be inspected at least once in a month for damage and deterioration. Close visual inspection is recommended in preference to load testing. This condition is particularly applicable to rope and bamboo ladders wherein fraying of ropes and damage to bamboo is likely to occur due to materials falling on them. When a ladder has been accidentally dropped it shall be inspected by the engineer-in-charge prior to re-use. Overhead protection shall be provided for workers under ladder. For detailed information regarding safety requirements for use of ladders, reference may be made to good practice [7(31)].

9.8.4 Opening in Walls

Whenever making of an opening in the existing wall is contemplated, adequate supports against the collapse or cracking of the wall portion above or roof or adjoining walls shall be provided.

9.8.4.1 Guarding of wall openings and holes

Wall opening barriers and screens shall be of such construction and mounting that they are capable of withstanding the intended loads safely. For detailed information reference may be made to good practice [7(32)]. Every wall opening from which there is a drop of more than 1 200 mm shall be guarded by one of the following:

- a) *Rail, roller, picket fence, half door or equivalent barrier* — The guard may be removable but should preferably be hinged or otherwise mounted so as to be conveniently replaceable. Where there is danger to persons working or passing below on account of the falling materials, a removable toe board or the equivalent shall also be provided. When the opening is not in use for handling materials, the guards shall be kept in position regardless of a door on the opening. In addition, a grab handle shall be provided on each side of the opening. The opening should have a sill that projects above the floor level at least 25 mm.
- b) Extension platform, into which materials may be hoisted for handling, shall be of full length of the opening and shall have side rails or equivalent guards.

9.8.4.2 Every chute wall opening from which there is a

drop of more than 1 200 mm shall be guarded by one or more of the barriers specified in 9.8.4.1 or as required by the conditions.

9.8.5 Projection from Walls

Whenever projections cantilever out of the walls, temporary formwork shall be provided for such projections and the same shall not be removed till walls over the projecting slabs providing stability load against overturning are completely constructed.

9.9 Common Hazards During Walling

9.9.1 Lifting of Materials for Construction

Implements used for carrying materials to the top of scaffoldings shall be of adequate strength and shall not be overloaded during the work. Where workers have to work below scaffoldings or ladder, overhead protection against the falling materials shall be provided. Care shall be taken in carrying large bars, rods, etc, during construction of the walls to prevent any damage to property or injury to workers.

9.9.2 Haulage of Materials

9.9.2.1 In case of precast columns, steel beams, etc, proper precautions shall be taken to correctly handle, use and position them with temporary arrangement of guys till grouting of the base.

9.9.2.2 Manila or sisal rope shall not be used in rainy season for hoisting of heavy materials as they lose their strength with alternate wetting and drying.

9.9.3 Electrical Hazards

No scaffolding, ladder, working platform, gangway runs, etc, shall exist within 3 m from any uninsulated electric wire.

9.9.4 Fire Hazards

Gangways and the ground below the scaffolding shall be kept free from readily combustible materials including waste and dry vegetation at all times.

Where extensive use of blow torch or other flame is anticipated scaffoldings, gangways, etc, shall be constructed with fire resistant materials. A portable dry powder extinguisher of 3 kg capacity shall be kept handy.

9.9.5 Mechanical Hazards

Care shall be taken to see that no part of scaffolding or walls is struck by truck or heavy moving equipment and no materials shall be dumped against them to prevent any damage. When such scaffoldings are in or near a public thoroughfare, sufficient warning lights and boards shall be provided on the scaffoldings to make them clearly visible to the public.

9.9.6 Fragile Materials

During glazing operations, adequate precautions shall be taken to ensure that the fragments of fragile materials do not cause any injury to workers or general public in that area by way of providing covering to such material, side protection at work site, etc.

9.10 Roofing

9.10.1 Prevention of accidental falling of workers during the construction of roofs shall be ensured by providing platforms, catch ropes, etc. If the materials are to be hoisted from the ground level to the roof level, adequate precautions shall be taken by way of correct technique of handling, hoists of sufficient strength to cater for the quantity of stores to be hoisted and prevention of overloading such hoists or buckets, prevention of overturning of hoists or buckets. Where in a multi-storeyed building, the floor of one storey is to be used for storage of materials for the construction of roofs, it shall be ensured that the quantum of stores kept on the floor along with the load due to personnel engaged in the construction work shall not exceed the rated capacity of the floors.

9.10.2 While roofing work is being done with corrugated galvanized iron or asbestos cement sheets, it shall be ensured that joints are kept secured in position and do not slip, thus causing injury to workers. Workers should not be allowed to walk on asbestos cement sheets but should be provided with walking boards. While working with tiles, it shall be ensured that they are not kept loose on the roof site resulting in falling of tiles on workers in lower area. In slopes of more than 30° to the horizontal, the workers shall use ladders or other safety devices to work on the roof.

9.10.3 If any glass work is to be carried out in the roof, it shall be ensured that injury to passerby due to breaking of glass is prevented. During wet conditions, the workers shall be allowed to proceed to work on a sloping roof, only if the engineer-in-charge has satisfied himself that the workers are not likely to slip due to wet conditions.

9.10.4 Flat Roof

In any type of flat roof construction, any formwork provided shall be properly designed and executed to ensure that it does not collapse during construction. During actual construction of roof, frequent inspection of the formwork shall be carried out to ensure that no damage has occurred to it.

9.10.5 While using reinforcement in roofs, it shall be ensured that enough walking platforms are provided in the reinforcement area to ensure safe walking to the concreting area. Loose wires and unprotected rod ends shall be avoided.

9.10.6 Guarding of Floor Openings and Floor Holes

9.10.6.1 Every temporary floor opening shall have railings, or shall be constantly attended by someone. Every floor hole into which persons can accidentally fall shall be guarded by either,

- a) a railing with toe board on all exposed sides; or
- b) a floor hole cover of adequate strength and it should be hinged in place. When the cover is not in place, the floor hole shall be constantly attended by someone or shall be protected by a removable railing.

9.10.6.2 Every stairway floor opening shall be guarded by a railing on all exposed sides, except at entrance to stairway. Every ladder way floor opening or platform shall be guarded by a guard railing with toe board on all exposed sides (except at entrance to opening), with the passage through the railing either provided with a swinging gate or so offset that a person cannot walk directly into the opening.

9.10.6.3 Guarding of open-side floors and platform

Every open-sided floor or platform 1 200 mm or more above adjacent floor or ground level shall be guarded by a railing (or the equivalent) on all open sides, except where there is entrance to ramp, stair-way, or fixed ladder. The railing shall be provided with a toe board beneath the open sides wherever,

- a) persons may pass;
- b) there is moving machinery; or
- c) there is equipment with which falling materials could create a hazard.

For detailed information, reference may be made to good practice [7(32)].

9.11 Additional Safety Requirements for Erection of Concrete Framed Structures (High-Rise Buildings)

9.11.1 Handling of Plant

9.11.1.1 Mixers

All gears, chains and rollers of mixers shall be properly guarded. If the mixer has a charging skip the operator shall ensure that the workers are out of danger before the skip is lowered. Railings shall be provided on the ground to prevent anyone walking under the skip while it is being lowered.

All cables, clamps, hooks, wire ropes, gears and clutches, etc, of the mixer, shall be checked and cleaned, oiled and greased, and serviced once a week. A trial run of the mixer shall be made and defects shall be removed before operating a mixer.

When workers are cleaning the inside of the drums, operating power of the mixer shall be locked in the off position and all fuses shall be removed and a suitable notice hung at the place.

9.11.1.2 Cranes

Crane rails where used shall be installed on firm ground and shall be properly secured. In case of tower cranes, it shall be ensured that the level difference between the two rails remains within the limits prescribed by the manufacturer to safeguard against toppling of the crane. Requirements for tower cranes as given in 7.3 shall also be complied with.

Electrical wiring which can possibly touch the crane or any member being lifted shall be removed, or made dead by removing the controlling fuses and in their absence controlling switches.

All practical steps shall be taken to prevent the cranes being operated in dangerous proximity to a live overhead power line. In particular, no member of the crane shall be permitted to approach within the minimum safety distances as laid down in 8.2.23 (a).

If it becomes necessary to operate the cranes with clearances less than those specified above, it shall be ensured that the overhead power lines shall invariably be shut off during the period of operation of cranes. Location of any underground power cables in the area of operation shall also be ascertained and necessary safety precautions shall be taken.

Cranes shall not be used at a speed which causes the boom to swing.

A crane shall be thoroughly examined at least once in a period of 6 months by a competent person who shall record a certificate of the check.

The operator of the crane shall follow the safe reach of the crane as shown by the manufacturer.

No person shall be lifted or transported by the crane on its hook or boom.

Toe boards and limit stops should be provided for wheel barrows on the loading/unloading platforms. Material should be loaded securely with no projections.

Concrete buckets handled by crane or overhead cableway shall be suspended from deep throated hooks, preferably equipped with swivel and safety latch. In the concrete buckets, both bottom drop type and side drop type, closing and locking of the exit door of the bucket shall always be checked by the man-in-charge of loading concrete in the bucket to avoid accidental opening of the exit door and consequent falling of concrete.

Interlocking or other safety devices should be installed

at all stopping points of the hoists. The hoists shaft way should be fenced properly.

When the bucket or other members being lifted are out of sight of the crane operator, a signaller shall be posted in clear view of the receiving area and the crane operator.

A standard code of hand signals shall be adopted in controlling the movements of the crane, and both the driver and the signaller shall be thoroughly familiar with the signals.

The driver of the crane shall respond to signals only from the appointed signaller but shall obey stop signal at any time no matter who gives it.

If a travelling gantry crane is operating over casting beds, a warning signal which sounds automatically during travel should be provided to avoid accidents to workers crossing or standing in the path of the moving loads.

9.11.1.3 Trucks

When trucks are being used on the site, traffic problems shall be taken care of. A reasonably smooth traffic surface shall be provided. If practicable, a loop road shall be provided to permit continuous operation of vehicles and to eliminate their backing. If a continuous loop is not possible, a turnout shall be provided. Backing operations shall be controlled by a signaller positioned so as to have a clear view of the area behind the truck and to be clearly visible to the truck driver. Movement of workers and plant shall be routed to avoid crossing, as much as possible, the truck lanes.

9.11.1.4 Concrete pumps (Air compressor operated)

Safety requirements in accordance with good practice [7(33)] shall be followed.

9.11.2 Formwork

9.11.2.1 Formwork shall be designed after taking into consideration spans, setting temperature of concrete, dead load and working load to be supported and safety factor for the materials used for formwork {see also with good practice [7(26)]}.

9.11.2.2 All timber formwork shall be carefully inspected before use and members having cracks and excessive knots shall be discarded.

9.11.2.3 As timber centering usually takes an initial set when vertical load is applied, the design of this centering shall make allowance for this factor.

9.11.2.4 The vertical supports shall be adequately braced or otherwise secured in position that these do not fall when the load gets released or the supports are accidentally hit.

9.11.2.5 Tubular steel centering shall be used in accordance with the manufacturer's instructions. When tubular steel and timber centering is to be used in combination necessary precautions shall be taken to avoid any unequal settlement under load.

9.11.2.6 A thorough inspection of tubular steel centering is necessary before its erection and members showing evidence of excessive resting, kinks, dents or damaged welds shall be discarded. Buckled or broken members shall be replaced. Care shall also be taken that locking devices are in good working order and that coupling pins are effectively aligned to frames.

9.11.2.7 After assembling the basic unit, adjustment screws shall be set to their approximate final adjustment and the unit shall be level and plumb so that when additional frames are installed the tower shall be in level and plumb. The centering frames shall be tied together with sufficient braces to make a rigid and solid unit. It shall be ensured that struts and diagonals braces are in proper position and are secured so that frames develop full load carrying capacity. As erection progresses, all connecting devices shall be in place and shall be fastened for full stability of joints and units.

9.11.2.8 In case of timber posts, vertical joints shall be properly designed. The connections shall normally be with bolts and nuts. Use of rusted or spoiled threaded bolts and nuts shall be avoided.

9.11.2.9 Unless the timber centering is supported by a manufacturer's certificate about the loads it can stand, centering shall be designed by a competent engineer.

9.11.2.10 Centering layout shall be made by a qualified engineer and shall be strictly followed. The bearing capacity of the soil shall be kept in view for every centering job. The effect of weather conditions as dry clay may become very plastic after a rainfall and show marked decrease in its bearing capacity.

9.11.2.11 Sills under the supports shall be set on firm soil or other suitable material in a pattern which assures adequate stability for all props. Care shall be taken not to disturb the soil under the supports. Adequate drainage shall be provided to drain away water coming due to rains, washing of forms or during the curing of the concrete to avoid softening of the supporting soil strata.

9.11.2.12 All centering shall be finally, inspected to ensure that,

- a) footings or sills under every post of the centering are sound.
- b) all lower adjustment screws or wedges are snug against the legs of the panels.
- c) all upper adjustment screws or heads of jacks are in full contact with the formwork.

- d) panels are plumb in both directions.
- e) all cross braces are in place and locking devices are in closed and secure position.
- f) In case of *Chhajjas* and balconies, the props shall be adequate to transfer the load to the supporting point.

9.11.2.13 During pouring of the concrete, the centering shall be constantly inspected and strengthened, if required, wedges below the vertical supports tightened and adjustment screws properly adjusted as necessary. Adequate protection of centering shall be secured from moving vehicles or swinging loads.

While pouring concrete, it should be placed in such a manner that the load should be transmitted to the support of formwork uniformly without causing high eccentric load.

Caution shall be exercised to avoid heap storage of bricks/sand in roof/floor slab as it may lead to failure of slab.

9.11.2.14 Forms shall not be removed earlier than as laid down in the specifications and until it is certain that the concrete has developed sufficient strength to support itself and all loads that will be imposed on it. Only workers actually engaged in removing the formwork shall be allowed in the area during these operations. Those engaged in removing the formwork shall wear helmets, gloves and heavy soled shoes and approved safety belts if adequate footing is not provided above 2 m level. While cutting any tying wires in tension, care shall be taken to prevent backlash which might hit a workman.

9.11.2.14.1 The particular order in which the supports are to be dismantled should be followed according to the instructions of the site engineer.

9.11.3 Ramps and Gangways

9.11.3.1 Ramps and gangways shall be of adequate strength and evenly supported. They shall either have a sufficiently flat slope or shall have cleats fixed to the surface to prevent slipping of workers. Ramps and gangways shall be kept free from grease, mud, snow or other slipping hazards or other obstructions leading to tripping and accidental fall of a workman.

9.11.3.1.1 Ramps and gangways meant for transporting materials shall have even surface and be of sufficient width and provided with skirt boards on open sides.

9.11.4 Materials Hoists

9.11.4.1 The hoist should be erected on a firm base, adequately supported and secured. All materials supporting the hoist shall be appropriately designed and strong enough for the work intended and free from defects.

9.11.4.2 The size of the drum shall match the size of the rope. Not less than two full turns of rope shall remain on the drum at all times. Ropes shall be securely attached to the drum.

9.11.4.3 All ropes, chains and other lifting gear shall be properly made of sound materials, free from defects and strong enough for the work intended. They shall be examined by a competent person who shall clearly certify the safe working load on each item and the system.

9.11.4.4 Hoistways shall be protected by a substantial enclosure at ground level, at all access points and wherever persons may be struck by any moving part.

9.11.4.5 Gates at access points should be at least 2 m high, wherever possible. Gates shall be kept closed at all times except when required open for immediate movement of materials at that landing place.

9.11.4.6 All gates shall be fitted with electronic or mechanical interlocks to prevent movement of the hoist in the event of a gate being opened.

9.11.4.7 Winches used for hoists shall be so constructed that a brake is applied when the control lever or switch is not held in the operating position (dead-man's handle).

9.11.4.8 The hoist tower shall be tied to a building or structure at every floor level or at least every 3 m. The height of the tower shall not exceed 6 m after the last tie or a lesser height as recommended by the manufacturer. All ties on a hoist tower shall be secured using right angled couples.

9.11.4.9 The hoist shall be capable of being operated only from one position at a time. It shall not be operated from the cage. The operator shall have a clear view of all levels or, if he has not, a clear and distinct system of signaling shall be employed.

9.11.4.10 All hoist platform shall be fitted with guards and gates to a height of at least 1 m, to prevent materials rolling/falling from the platform.

9.11.4.11 Where materials extend over the height of the platform guards, a frame shall be fitted and the materials secured to it during hoisting/lowering. Care should be taken to ensure that neither the frame nor materials interfere or touch any part of the hoisting mechanism.

9.11.4.12 The platform of a goods hoist shall carry a notice stating,

- a) the safe working load; and
- b) that passengers shall not ride on the hoist.

9.11.4.13 All hoist operators shall be adequately trained

and competent, and shall be responsible for ensuring that the hoist is not overloaded or otherwise misused.

9.11.4.14 All hoists shall be tested and thoroughly examined by a competent person before use on a site, after substantial alteration, modification or repair of hoists, and at least every 6 months.

9.11.4.15 Every hoist shall be inspected at least once each week by a competent person and a record of these inspections kept.

9.11.5 *Prestressed Concrete*

9.11.5.1 In pre-stressing operations, operating, maintenance and replacement instructions of the supplier of the equipment shall be strictly adhered to.

9.11.5.2 Extreme caution shall be exercised in all operations involving the use of stressing equipment as wires/strands under high tensile stresses become a lethal weapon.

9.11.5.3 During the jacking operation of any tensioning element(s) the anchor shall be kept turned up close to anchor plate, wherever possible, to avoid serious damage, if a hydraulic line fails.

9.11.5.4 Pulling-headers, bolts and hydraulic jacks/rams shall be inspected for signs of deformation and failure. Threads on bolts and nuts should be frequently inspected for diminishing cross section. Choked units shall be carefully cleaned.

9.11.5.5 Care shall be taken that no one stands in line with the tensioning elements and jacking equipment during the tensioning operations and that no one is directly over the jacking equipment when deflection is being done. Signs and barriers shall be provided to prevent workers from working behind the jacks when the stressing operation is in progress.

9.11.5.6 Necessary shields should be put up immediately behind the prestressing jacks during stressing operations.

9.11.5.7 Wedges and other temporary anchoring devices shall be inspected before use.

9.11.5.8 The prestressing jacks shall be periodically examined for wear and tear.

9.11.5.9 Prestressing shall be done in accordance with Part 6 'Structural Design, Section 5 Plain, Reinforced and Prestressed Concrete, Subsection 5B Prestressed Concrete' of the Code.

9.11.6 *Erection of Prefabricated Members*

9.11.6.1 A spreader beam shall be used wherever possible so that the cable can be as perpendicular to the members being lifted as practical. The angle between the cable and the members to be lifted shall not be less than 60°.

9.11.6.2 The lifting wires shall be tested for double the load to be handled at least once in six months. The guy line shall be of adequate strength to perform its function of controlling the movement of members being lifted.

9.11.6.3 Temporary scaffolding of adequate strength shall be used to support precast members at predetermined supporting points while lifting and placing them in position and connecting them to other members.

9.11.6.4 After erection of the member, it shall be guyed and braced to prevent it from being tipped or dislodged by accidental impact when setting the next member.

9.11.6.5 Precast concrete units shall be handled at specific picking points and with specific devices. Girders and beams shall be braced during transportation and handled in such a way as to keep the members upright. Lifting, handling and installation of prefabricated members shall be in accordance with Part 6 'Structural Design, Section 7 Prefabrication and Systems Building: Subsection 7A Prefabricated Concrete' of the Code.

9.11.6.6 Methods of assembly and erection specified by the designer, shall be strictly adhered to at site. Immediately on erecting any unit in position, temporary connections or supports as specified shall be provided before releasing the lifting equipment. The permanent structural connections shall be established at the earliest opportunity.

9.11.7 *Heated Concrete*

When heaters are being used to heat aggregates and other materials and to maintain proper curing temperatures, the heaters shall be frequently checked for functioning and precautions shall be taken to avoid hazards in using coal, liquid, gas or any other fuel.

9.11.8 *Structural Connections*

9.11.8.1 When reliance is placed on bond between precast and *in-situ* concrete the contact surface of the precast units shall be suitably prepared in accordance with the specifications.

9.11.8.2 The packing of joints shall be carried out in accordance with the assembly instructions.

9.11.8.3 Levelling devices, such as wedges and nuts which have no load bearing function in the completed structure shall be released or removed as necessary prior to integrating the joints.

9.11.8.4 If it becomes necessary to use electric power for *in-situ* work, the same should be stepped down to a safe level as far as possible.

9.11.9 Workers working in any position where there is a falling hazard shall wear safety belts or other adequate

protection shall be provided.

9.12 Additional Safety Requirements for Erection of Structural Steel Work

9.12.1 Safety Organization

The agency responsible for erecting the steel work should analyze the proposed erection scheme for safety; the erection scheme should cover safety aspects right from the planning stage up to the actual execution of the work.

9.12.2 Safety of Workpersons

9.12.2.1 General

While engaging persons for the job the supervisor should check up and make sure that they are skilled in the particular job they have to perform.

The helmets shall be worn properly and at all times during the work and shall conform to the accepted standard [7(28)].

The safety goggles shall be used while performing duties which are hazardous to eye like drilling, cutting and welding. The goggles used shall conform to the accepted standard [7(34)] and should suit individual workers.

The welders and gas cutters shall be equipped with proper protective equipment like gloves, safety boots, aprons and hand shields [see accepted standard 7(35)]. The filter glass of the hand shield shall conform to the accepted standard [7(34)] and should be suitable to the eyes of the particular worker.

When the work is in progress, the area shall be cordoned off by barricades to prevent persons from hitting against structural components, or falling into excavated trenches or getting injured by falling objects.

Warning signs shall be displayed where necessary to indicate hazards, for example (a) '440 V', (b) 'DO NOT SMOKE', (c) 'MEN WORKING AHEAD', etc. Hand lamps shall be of low voltage preferably 24 V to prevent electrical hazards.

All electrically operated hand tools shall be provided with double earthing.

9.12.2.2 Anchors for guys or ties shall be checked for proper placement. The weight of concrete in which the anchors are embedded shall be checked for uplift and sliding. Split-end eye anchors shall only be used in good, solid rock. The first load lifted by a guy derrick shall be kept at a small height for about 10 min and the anchors immediately inspected for any signs or indications of failure.

9.12.2.3 When a number of trusses or deep girders are loaded in one car or on one truck, all but one being

lifted shall be tied back unless they have been tied or braced to prevent their falling over and endangering men unloading.

9.12.2.4 The erection gang shall have adequate supply of bolts, washers, rivets, pins, etc, of the correct size. Enough number of bolts shall be used in connecting each piece using a minimum of two bolts in a pattern to ensure that the joint will not fail due to dead load and erection loads. All splice connections in columns, crane girders, etc, shall be completely bolted or riveted or welded as specified in the drawing before erection.

9.12.2.5 Girders and other heavy complicated structural members may require special erection devices like cleats and hooks, which can be shop assembled and bolted or riveted or welded to the piece and may be left permanently in the place after the work.

9.12.2.6 If a piece is laterally unstable when picked at its centre, use of a balance beam is advisable, unless a pair of bridles slings can be placed far enough apart, for them to act as safe lifting points. The top flange of a truss, girder or long beam may be temporarily reinforced with a structural member laid flat on top of the member and secured temporarily.

9.12.2.7 On deep girders, and even on some trusses, a safety 'bar' running their full length will aid the riggers, fitters and others employed on the bottom flange or bottom chord to work with greater safety. This can be a single 16 mm diameter wire rope through vertical stiffeners of such members about 1 m above the bottom flange and clamped at the ends with wire rope clamps. If the holes cannot be provided, short eye bolts can be welded to the webs of the girder at intervals to be removed and the surface chipped or ground to leave it smooth after all work on the piece has been completed.

9.12.2.8 Safety belts shall always be available at work spot to be used, whenever necessary. The rope shall be chemically treated to resist dew and rotting. These shall not be tied on sharp edges of steel structures. They shall be tied generally not more than 2 m to 3 m away from the belt.

9.12.2.9 On a guy derrick or climbing crane job, the tool boxes used by the erection staff shall be moved to the new working floor each time the rig is changed. On a mobile crane job, the boxes shall be moved as soon as the crane starts operating in a new area not too far away for the men to reach the boxes conveniently. While working a tall and heavy guy derrick, it is advisable to control tension in guys by hand winches to avoid jerks, which may cause an accident.

9.12.2.10 The proper size, number and spacing of wire rope clamps shall be used, depending on the diameter of the wire rope. They shall be properly fixed in

accordance with the procedure given in the accepted standard [7(36)]. They shall be checked as soon as the rope has been stretched, as the rope, especially if new, tends to stretch under the applied load, which in turn may cause it to shrink slightly in diameter. The clamps shall then be promptly tightened to take care of this new condition. In addition, the clamps shall be inspected frequently to be sure that they have not slipped and are tight enough.

9.12.2.11 When the men can work safely from the steel structure itself, this is preferable to hanging platforms or scaffolds, as it eliminates additional operations, which in turn, reduces the hazard of an accident. To aid men working on floats or scaffolds, as well as men in erection gangs, or other gangs using small material, such as bolts and drift pins, adequate bolt baskets or similar containers with handles of sufficient strength and attachment to carry the loaded containers, shall be provided. The men should be trained to use such containers, and to keep small tools gathered up and put away in tool boxes when not in use. Material shall not be dumped overboard when a scaffold is to be moved. Rivet heaters shall have safe containers or buckets for hot rivets left over at the end of the day.

9.12.2.12 During the erection of tall buildings, it is desirable to use nylon nets of sufficient width at a height of 3 m to 4 m from ground to provide safety to people. The safety net should be made from man-made or machine-made fibre ropes which are UV stabilized and conforming to the accepted standard [7(37)].

9.12.2.13 *Safety against fire*

A fire protection procedure is to be set up if there is to be any flame cutting, burning, heating, riveting or any operation that could start a fire. For precautions to be observed during welding and cutting operations, reference may be made to good practice [7(38)]. The workers should be instructed not to throw objects like hot rivets, cigarette stubs, etc, around. Sufficient fire extinguishers shall be placed at strategic points. Extinguishers shall always be placed in cranes, hoists, compressors and similar places. Where electrical equipment are involved, CO₂ or dry powder extinguishers shall be provided {see also good practice [7(24)]}.

9.12.2.14 Riding on a load, tackle or runner shall be prohibited.

9.12.2.15 The load shall never be allowed to rest on wire ropes. Ropes in operation should not be touched. Wire rope with broken strand shall not be used for erection work. Wire ropes/manila ropes conforming to acceptable standards [7(39)] shall be used for guying.

9.12.2.16 *Lifting appliances*

Precautions as laid down in **9.11.1.2** shall be followed.

9.12.2.17 *Slings*

Chains shall not be joined by bolting or wiring links together. They shall not be shortened by tying knots. A chain in which the links are locked, stretched or do not move freely shall not be used. The chain shall be free of kinks and twists. Proper eye splices shall be used to attach the chain hooks.

Pulley blocks of the proper size shall be used to allow the rope free play in the sheave grooves and to protect the wire rope from sharp bends under load. Idle sling should not be carried on the crane hook alongwith a loaded sling. When idle slings are carried they shall be hooked.

While using multilegged slings, each sling or leg shall be loaded evenly and the slings shall be of sufficient length to avoid a wide angle between the legs.

9.12.2.18 *Riveting operations*

9.12.2.18.1 *Handling rivets*

Care shall be taken while handling rivets so that they do not fall, strike or cause injury to men and material below. Rivet catchers shall have false wooden bottoms to prevent rivets from rebounding.

9.12.2.18.2 *Riveting dollies*

Canvas, leather or rope slings shall be used for riveting dollies. Chain shall not be used for the purpose.

9.12.2.18.3 *Riveting hammers*

Snaps and plungers of pneumatic riveting hammers shall be secured to prevent the snap from dropping out of place. The nozzle of the hammer shall be inspected periodically and the wire attachment renewed when worn.

9.12.2.18.4 *Fire protection*

The rivet heating equipment should be as near as possible to the place of work. A pail of water shall always be kept ready for quenching the fire during riveting operations and to prevent fires when working near inflammable materials.

9.12.2.19 *Welding and gas cutting*

9.12.2.19.1 For safety and health requirements in electric gas welding and cutting operations, reference may be made to good practice [7(40)]. The recommendations given in **9.12.2.19.2** to **9.12.2.19.4** are also applicable.

9.12.2.19.2 All gas cylinders shall be used and stored in the upright position only and shall be conveyed in trolleys. While handling by cranes they shall be carried in cages. The cylinders shall be marked 'full' or 'empty' as the case may be. Gas cylinders shall be stored away

from open flames and other sources of heat. Oxygen cylinders shall not be stored near combustible gas, oil, grease and similar combustible materials. When the cylinders are in use, cylinder valve key or wrench shall be placed in position. Before a cylinder is moved, cylinder valve shall be closed. All cylinder valves shall be closed when the torches are being replaced or welding is stopped for some reason. The cylinder valve and connections shall not be lubricated.

9.12.2.19.3 Gas cutting and welding torches shall be lighted by means of special lighters and not with matches. The cables from welding equipment should be placed in such a way that they are not run over by traffic. Double earthing shall be provided. Before undertaking welding operations near combustible materials, suitable blanketing shall be provided and fire extinguishers kept nearby. Welding shall not be undertaken in areas where inflammable liquids and gases are stored.

9.12.2.19.4 Gas lines and compressed air lines shall be identified by suitable colour codes for easy identification, to avoid confusion and to prevent fire and explosion hazards.

9.12.3 Safety of Structure

9.12.3.1 General

The structure itself should be safeguarded during its erection. The first truss of the roof system shall be guyed on each side before the hoisting rope is detached from it. After the subsequent trusses and roof purlins are erected, protective guides shall be firmly established and the required wind bracings shall be erected to prevent the whole structure being blown over by a sudden gale at night. Bracing and guying precautions shall be taken on every structure until it is complete. Guying shall be specifically done for trusses and structural components which after their erection form an erection device. On structures used for temporary material storage overloading shall be avoided.

9.12.3.1.1 Erection of columns shall be immediately followed by vertical bracing between columns before the roof structure is erected.

9.13 Miscellaneous Items

9.13.1 Staircase Construction

While staircase is under construction, depending on the type of construction, namely, concrete or brickwork, etc, suitable precautions shall be taken by way of support, formworks, etc, to prevent any collapse. Workers or any other person shall not be allowed to use such staircases till they are tested and found fit for usage by the Authority/engineer-in-charge. Till the permanent handrails are provided, temporary provisions

like ropes, etc, shall be provided on staircases prior to commencement of use of such staircases.

9.13.2 Lift Wells

Till the installation of the lift is completed, lift wells shall be protected with check boards or railings together with notice boards, danger lights, etc, to prevent persons accidentally falling into the wells. The handrails provided shall be capable of withstanding pressure exerted due to normal bumping of an individual against the same.

9.13.3 Construction Involving the Use of Hot Bituminous Tar Materials

9.13.3.1 Safety programme

9.13.3.1.1 General

On all major works, an experienced and competent foreman or supervisor shall be placed in-charge of the work, and shall be made responsible for the strict observance of the safety rules. He shall stock the necessary protective equipment, fire extinguishing equipment, first-aid kit, etc. He shall also keep a record of the accidents taking place on any particular job, with reasons thereof, and shall suggest suitable remedial measures to the management for prevention thereof.

9.13.3.1.2 Protective covering

Workers engaged on jobs involving handling of hot bitumen, tar, and bituminous mixtures shall use protective wears, such as boots and gloves, preferably of asbestos or otherwise of rubber; goggles and helmet. No workers shall be permitted to handle such materials without wearing the needed protective covering.

9.13.3.1.3 Fire fighting arrangements

When heating and handling of hot bituminous materials is to be done in the open, sufficient stocks of clean dry sand or loose earth shall be made available at the work site to cope with any resultant fires. When neither such materials are available, nor are any suitable type of fire extinguishers provided at the work site in the open, and reliance has to be on using water for fighting any fire, the water supply available should be in abundance and the water shall be applied to the fire in the form of spray. When heating of bituminous materials is carried out in enclosed spaces, sufficient number of properly maintained dry powder fire extinguisher or foam extinguisher conforming to accepted standards [7(23)] shall be kept in readiness on the work site.

9.13.3.2 Sprayer, spreader/paver

9.13.3.2.1 Sprayer

The sprayer shall be provided with a fire resisting screen. The screen shall have an observation window.

Piping for hot tar and bitumen shall be adequately insulated to protect workers from injury by burns. Flexible piping work under positive pressure shall be of metal which shall be adequately insulated. Workers shall not stand facing the wind directions while spraying hot binder, lest it may fall on them causing burns.

9.13.3.2.2 Spreader/Paver

Spreaders in operation shall be protected by signals, signs or other effective means. People should be warned against walking over hot mixture laid. Gravel spreaders shall always keep a safe distance from sprayer. Elevated platforms on spreaders shall be protected by suitable railing and be provided with an access ladder.

9.13.3.3 Equipment for heating of bitumen and tars

9.13.3.3.1 Tanks, vats, kettles, pots, drums and other vessels for heating tar, bitumen and other bituminous materials shall be,

- a) adequately resistant to damage by heat, transportation, etc;
- b) capable of holding a full load without danger of collapse, bursting or distortion;
- c) provided with a close fitting cover suitable for smothering a fire in the vessel or protection from rain; and
- d) leak proof, and provided with suitable outlets which can be controlled for taking out the hot material.

9.13.3.3.2 Suitable indicator gauges shall be used to ascertain level and temperature of the material in the boiler. On no account shall workers be allowed to peep into the boiler for this purpose. For ascertaining levels, in small plants, dipstick may also be used.

9.13.3.3.3 Gas and oil-fired bitumen and tar kettles or pots shall be equipped with burners, regulators and safety devices of types approved by the Authority. Heating appliances for vessels shall distribute the heat uniformly over the heating surface so as to avoid overheating. In case of bituminous mixtures using mineral aggregates filler together with bitumen, it is preferable to have some means for stirring as well. Only vessels heated by electricity shall be used inside buildings. Tar boilers shall never be used on combustible roof.

9.13.3.3.4 Buckets for hot bitumen, bituminous materials of tar shall have,

- a) the bail or handle firmly secured; and
- b) a second handle near the bottom for tipping.

9.13.3.3.5 Bitumen or tar boilers mounted on wheels for easy transport or towing shall preferably be provided with hand pumps for spraying purposes.

9.13.3.3.6 Vessels in operation shall be kept at a safe distance from combustible materials. When vessels are used in confined spaces, the gases, fumes and smoke generated shall be removed by exhaust ventilation or by forced ventilations. Vessels that are being heated shall not be left unattended. Pieces of bituminous material shall not be thrown into the hot vessels so as to cause splashing. Covers shall be kept closed when vessels are not in use. Containers shall not be filled with hot bitumen or tar to a level that might cause danger when they are carried or hoisted. Enough space shall be left in vessels for expansion of binder, when heated.

9.13.3.3.7 Bitumen/tar shall be kept dry and to avoid fire due to foaming, boiler shall have a device that prevents foam from reaching the burners or anti-foaming agents shall be used to control the same. Alternatively, to avoid fire due to foaming, the heating shall be at low temperature till the water entrapped, if any, is completely evaporated. Any water present in the boiler shall also be drained before using it for heating binders. No open light shall be used for ascertaining the level of binder in boilers. If a burner goes out, the fuel supply shall be cut off and the heating tube shall be thoroughly blown out by the fan so as to prevent a back fire.

9.13.3.3.8 Cutbacks shall not be heated over an open flame unless a water jacket is used. While they are being heated the vessel shall be kept open.

9.13.3.3.9 Piping shall not be warmed with burning rags and instead blow-lamps or similar devices shall be used.

9.13.3.3.10 Spilled bitumen or tar shall be promptly cleaned up around boilers.

9.13.3.3.11 Inspection openings shall not be opened while there is any pressure in the boiler.

9.13.3.3.12 When tanks are cleaned by steam, adequate precautions shall be taken to prevent any build up of pressure.

9.13.3.4 Handling bitumen/tar

Bitumen/tar shall not be heated beyond the temperature recommended by the manufacturer of the product. While discharging heated binder from the boiler, workers shall not stand opposite to the jet so as to avoid the possibility of hot binder falling on them. The container shall be handled only after closing the control valve. While handling hot bitumen/tar, workers shall exercise scrupulous care to prevent accidental spillage thereof. The buckets and cans in which the hot material is carried from boiler shall be checked before use to ensure that they are intact and safe. Mops and other applicators contaminated with bituminous materials shall not be stored inside buildings.

9.13.3.5 Bitumen plants

Safety requirements shall be in accordance with good practice [7(41)].

9.13.4 Timber Structure

Preventive measures against hazards in work places involving construction of timber structures shall be taken in accordance with good practice [7(42)].

9.14 Finishes**9.14.1 Painting, Polishing and Other Finishes**

Only the quantity of paint, thinner and polish required for the day's work should be kept at the work spot.

9.14.1.1 All containers of paint, thinner and polish which are not in actual use should be closed with tight fitting lids and kept at a safe place away from the actual work site.

9.14.1.2 A 5 kg dry powder fire extinguisher conforming to the accepted standard [7(43)] shall be kept handy.

9.14.1.3 Metal receptacles with pedal operated metal lids shall be kept handy at the work site for depositing used cotton rags/waste. The contents of such receptacles shall be disposed off before the end of each day's work at a safe place, preferably by burning under proper supervision.

9.14.1.4 All containers of paint shall be removed from the work site and deposited in the paint store before the close of day's work. Used paint brushes shall be cleaned and deposited in the store along with the containers.

9.14.1.5 Some paints/polishing and finishing materials are injurious to the health of workers. Adequate protective clothing, respiratory equipment, etc, shall be provided for the use of workers during such operations where necessary.

9.15 Fragile Fixtures

It shall be ensured that sufficient number of workers and equipment are provided to carry the fragile fixtures like sanitary fittings, glass panes, etc, to prevent injury to workers due to accidental dropping of such fixtures.

9.16 Safety in Special Operations

Safety in compressed air work, drilling, blasting and welding operations shall be in accordance with good practices [7(44)].

9.17 Electrical Installations and Lifts**9.17.1 Temporary Electrical Wiring**

9.17.1.1 Frayed and/or bare wires shall not be used for temporary electrical connections during construction.

All temporary wiring shall be installed and supervised by a competent electrician. Adequate protection shall be provided for all electrical wiring laid on floor which may have to be crossed over by construction machinery or by the workers. All flexible wiring connecting the electrical appliances shall have adequate mechanical strength and shall preferably be enclosed in a flexible metal sheath. Overhead wires/cables shall be so laid that they leave adequate head room.

9.17.1.2 All electrical circuits, other than those required for illumination of the site at night, shall be switched off at the close of day's work. The main switch board from which connections are taken for lighting, power operated machinery, etc, shall be located in an easily accessible and prominent place. No articles of clothing nor stores shall be kept at the back of or over the board or anywhere near it. One 3 kg/4.5 kg CO₂ extinguisher or one 5 kg dry powder extinguisher conforming to the accepted standard [7(43)] shall be provided near the switch board.

9.7.1.3 Requirements as given in 12 of Part 8 'Building Services, Section 2 Electrical and Allied Installations' of the Code shall also be complied with.

9.17.2 Permanent Electrical Installations

Besides the fire safety measures for electrical installations covered under 9.17.1, safety in electric installations in buildings and installations of lifts shall be in accordance with 12 of Part 8 'Building Services, Section 2 Electrical and Allied Installations' of the Code, and Part 8 'Building Services, Section 5 Installation of Lifts, Escalators and Moving Walks' of the Code, respectively.

9.18 General Safety Requirements for Workplace**9.18.1 Sanitation**

- a) Adequate toilet facilities shall be provided for the workers within easy access of their place of work. The total number to be provided shall be not less than one per 30 employees in any one shift.
- b) Toilet facilities shall be provided from the start of building operations, and connection to a sewer shall be made as soon as practicable.
- c) Every toilet shall be so constructed that the occupant is sheltered from view and protected from the weather and falling objects.
- d) Toilet facilities shall be maintained in a sanitary condition. A sufficient quantity of disinfectant shall be provided. Natural or artificial illumination shall be provided.

- e) An adequate supply of drinking water shall be provided, and unless connected to a municipal water supply, samples of the water shall be tested at frequent intervals by the Authority.

9.18.2 Fire Protection

9.18.2.1 In addition to the provision of fire extinguishers, as specified in this part of the Code, other fire extinguishing equipment shall also be provided and conveniently located within the building under construction or on the building site, as required by the Authority.

9.18.2.1.1 All fire extinguishers shall be maintained in a serviceable condition at all times in accordance with good practice [7(24)] and all necessary guidelines regarding fire protection at workplaces followed in accordance with good practice [7(21)].

9.18.2.1.2 It shall be ensured that all workers and supervisory staff are fully conversant with the correct operation and use of fire extinguishers provided at the construction site.

9.18.2.1.3 Telephone number of local fire brigade should be prominently displayed near each telephone provided at construction site.

9.18.2.1.4 Watch and ward services should be provided at construction sites during holidays and nights.

9.18.2.2 Access shall be provided and maintained at all times to all fire fighting equipment, including fire hose, extinguishers, sprinkler valves and hydrants.

9.18.2.2.1 Approach roads for fire fighting should be planned, properly maintained and kept free from blockage. Width of approach road should be not less than 5 m to facilitate fire fighting operations.

9.18.2.2.2 Emergency plan and fire order specifying the individual responsibility in the event of fire should be formulated and mock drills should be practised periodically in case of large and important construction sites to ensure upkeep and efficiency of fire fighting appliances.

9.18.2.2.3 Periodical inspection should be carried out to identify any hazard and proper records maintained and follow up action taken.

9.18.2.2.4 Evacuation facilities and fire exits should be provided at all locations susceptible to fire hazards.

9.18.2.3 Where the building plans require the installation of fixed fire fighting equipment, such as hydrants, stand pipes, sprinklers and underground water mains or other suitable arrangements for provision of water shall be installed, completed and made available for permanent use as soon as possible, but in any case not later than the stage at which the hydrants, etc, are

required for use as specified in **9.18.2.3.1** to **9.18.2.3.4**.

9.18.2.3.1 A stand pipe system (landing valves), permanent in nature shall be installed and made available before the building has reached the height of 15 m above the grade, and carried up with each floor.

9.18.2.3.2 The standpipe (landing valve/internal fire hydrant) and its installation shall conform to the accepted standards [7(45)].

9.18.2.3.3 The standpipe shall be carried up with each floor and securely capped at the top. Top hose outlets, should at all times, be not more than one floor below the floor under construction.

9.18.2.3.4 A substantial box, preferably of metal, should be provided and maintained near each hose outlet. The box should contain adequate lengths of hose to reach all parts of the floor as well as a short branch fitted with 12 mm or 20 mm nozzle.

9.18.2.4 Close liaison shall be maintained with the local Fire Brigade, during construction of all buildings above 15 m in height and special occupancies, like educational, assembly, institutional, industrial, storage, hazardous and mixed occupancies with any of the aforesaid occupancies having area more than 500 m² on each floor.

9.18.2.5 It is desirable that telephone system or other means of inter-communication system be provided during the construction of all buildings over 15 m in height or buildings having a plinth area in excess of 1 000 m².

9.18.2.6 All work waste, such as scrap timber, wood shavings, sawdust, paper, packing materials and oily waste shall be collected and disposed of safely at the end of each day's work. Particular care shall be taken to remove all waste accumulation in or near vertical shaft openings like stairways, lift-shaft, etc.

9.18.2.7 An independent water storage facility shall be provided before the commencement of construction operations for fire-fighting purposes. It shall be maintained and be available for use at all times.

9.18.2.8 Fire cut-offs

Fire walls and exit stairways required for a building should be given construction priority. Where fire doors, with or without automatic closing devices, are stipulated in the building plans they should be hung as soon as practicable and before any significant quantity of combustible material is introduced in the building.

9.18.2.8.1 As the work progresses, the provision of permanent stairways, stairway enclosures, fire walls and other features of the completed structure which will prevent the horizontal and vertical spread of fire should be ensured.

9.18.3 *Clothing*

9.18.3.1 It shall be ensured that the clothes worn by the workers be not of such nature as to increase the chances of their getting involved in accident to themselves or to others. As a rule, wearing of *Chaddars* or loose garments shall be prohibited.

9.18.3.2 Workers engaged in processes which splash liquid or other materials which will injure the skin shall have enough protective clothing to cover the body.

9.18.3.3 Individuals engaged in work involving use of naked flames (such as welding) shall not wear synthetic fibre or similar clothing which increases the risk of fire hazards.

9.18.4 *Safety Measures Against Fall Prevention*

Persons working at heights may use safety belts and harnesses. Provision of cat-walks, wire mesh, railings reduces chances of fall-ladder and scaffoldings, stagings, etc, should be anchored on firm footing and should be secured and railing should be provided as far as possible. All accesses should be barricaded to prevent accidental fall. For details as fall prevention reference may be made to good practice [7(46)].

9.18.5 *Falling Materials Hazard Prevention*

Preventive measures against falling materials hazards in work places shall be taken in accordance with good practice [7(47)].

9.18.6 *Disposal of Debris*

Preventive measures against hazards relating to disposal of debris shall be taken in accordance with [7(48)].

9.19 **Construction Machinery**

9.19.1 Specification and requirements of construction machinery used in construction or demolition work shall conform to accepted standards [7(49)].

9.19.2 For safety requirements for working with construction machinery, reference may be made to good practice [7(50)].

9.19.3 Petroleum powered air compressors, hoists, derricks, pumps, etc, shall be so located that the exhausts are well away from combustible materials. Where the exhausts are pipes to outside the building under construction, a clearance of at least 150 mm shall be maintained between such piping and combustible material.

9.19.4 Earthing/grounding of electrically powered equipment/tools shall be ensured. Also all electric powered equipment should be switched off from mains, after completion of day's job.

10 **SAFETY IN DEMOLITION OF BUILDINGS**

10.1 The safety requirements for carrying out demolition/dismantling work shall be as given in **10.2** to **10.15**.

10.2 **Planning**

Before beginning the actual work of demolition a careful study shall be made of the structure which is to be pulled down and also of all its surroundings. This shall, in particular, include study of the manner in which the various parts of the building to be demolished are supported and how far the stage by stage demolition will affect the safety of the adjoining structure. A definite plan of procedure for the demolition work, depending upon the manner in which the loads of the various structural parts are supported, shall be prepared and approved by the engineer-in-charge and this shall be followed as closely as possible, in actual execution of the demolition work. Before the commencement of each stage of demolition, the foreman shall brief the workers in detail regarding the safety aspects to be kept in view.

It should be ensured that the demolition operations do not, at any stage, and endanger the safety of the adjoining buildings. Moreover, the nuisance effect of the demolishing work on the use of the adjacent buildings should be kept to the minimum.

No structure or part of the structure or any floor or temporary support or scaffold, side wall or any device for equipment shall be loaded in excess of the safe carrying capacity, in its then existing condition.

Electrical installations for demolition sites shall be in accordance with **12** of Part 8 'Building Services, Section 2 Electrical and Allied Installations' of the Code.

10.3 **Precautions Prior to Demolition**

10.3.1 On every demolition job, danger signs shall be conspicuously posted all around the structure and all doors and openings giving access to the structure shall be kept barricaded or manned except during the actual passage of workers or equipment. However, provisions shall be made for at least two independent exits for escape of workers during any emergency.

10.3.2 During nights, red lights shall be placed on or about all the barricades.

10.3.3 Where in any work of demolition it is imperative, because of danger existing, to ensure that no unauthorized person shall enter the site of demolition during the outside hours; a watchman should be employed. In addition to watching the site he shall also be responsible for maintaining all notices, lights and barricades.

10.3.4 All the necessary safety appliances shall be issued to the workers and their use explained. It shall be ensured that the workers are using all the safety appliances while at work.

10.3.5 The power on all electrical service lines shall be shut off and all such lines cut or disconnected at or outside the property line, before the demolition work is started. Prior to cutting of such lines, the necessary approval shall be obtained from the electrical authorities concerned. The only exception will be any power lines required for demolition work itself.

10.3.6 All gas, water steam and other service lines shall be shut off and capped or otherwise controlled at or outside the building line, before demolition work is started.

10.3.7 All the mains and meters of the building shall be removed or protected from damage.

10.3.8 If a structure to be demolished has been partially wrecked by fire, explosion or other catastrophe, the walls and damaged roofs shall be shored or braced suitably.

10.3.9 Protection of the Public

10.3.9.1 Safety distances to ensure safety of the public shall be clearly marked and prominently sign posted. Every sidewalk or road adjacent to the work shall be closed or protected. All main roads, which are open to the public, shall be kept open to the public clear and unobstructed at all times. Diversions for pedestrians shall be constructed, where necessary for safety.

10.3.9.2 If the structure to be demolished is more than two storeyed or 7.5 m high, measured from the side walk or street which cannot be closed or safely diverted, and the horizontal distance from the inside of the sidewalk to the structure is 4.5 m or less, a substantial sidewalk shed shall be constructed over the entire length of the sidewalk adjacent to the structure, of sufficient width with a view to accommodating the pedestrian traffic without causing congestion. The side walk shed shall be lighted sufficiently to ensure safety at all times. For detailed information reference may be made to good practice [7(51)].

A toe board of at least 1 m high above the roof of the shed shall be provided on the outside edge and ends of the sidewalk shed. Such boards may be vertical or inclined outward at not more than 45°.

Except where the roof of a sidewalk shed solidly abuts the structure, the face of the sidewalk shed towards the building shall be completely closed by providing sheeting/planking to prevent falling material from penetrating into the shed.

The roof of sidewalk sheds shall be capable of

sustaining a load of 73 N/mm². Only in exceptional cases, say due to lack of other space, the storing of material on a sidewalk shed may be permitted in which case the shed shall be designed for a load of 146 N/mm². Roof of sidewalk shed shall be designed taking into account the impact of the falling debris. By frequent removal of loads it shall be ensured that the maximum load, at any time, on the roof of work shed is not more than 6 000 N/m². The height of sidewalk shed shall be such as to give a minimum clearance of 2.4 m.

Sidewalk shed opening, for loading purposes, shall be kept closed at all time except during actual loading operations.

The deck flooring of the sidewalk shed shall consist of plank of not less than 50 mm in thickness closely laid and deck made watertight. All members of the shed shall be adequately braced and connected to resist displacement of members or distortion of framework.

10.3.9.3 When the horizontal distance from the inside of the sidewalk to the structure is more than 4.5 m and less than 7.5 m, a sidewalk shed or fence or a substantial railing shall be constructed on the inside of the sidewalk or roadway along the entire length of the demolition side of the property with movable bars as may be necessary for the proper execution of the work.

NOTE — For guidance on management of pedestrians/cyclists/vehicles near road construction sites, reference may be made to IRC SP 55 : 2014 'Guidelines on traffic management in work zones'.

10.4 Precautions During Demolition

10.4.1 Prior to commencement of work, all material of fragile nature like glass shall be removed.

10.4.2 All openings shall be boarded up.

10.4.3 Dust shall be controlled by suitable means to prevent harm to workers.

10.4.4 Stacking of materials or debris shall be within safe limits of the structural member. Additional supports, where necessary, shall be given.

10.4.5 Adequate natural or artificial lighting and ventilation shall be provided for the workers.

10.5 Sequence of Demolition Operations

10.5.1 The demolition work shall be proceeded with in such a way that,

- a) it causes the least damage and nuisance to the adjoining building and the members of the public; and
- b) it satisfies all safety requirements to avoid any accidents.

10.5.2 All existing fixtures required during demolition

operations shall be well protected with substantial covering to the entire satisfaction of the rules and regulations of the undertakings or they shall be temporarily relocated.

10.5.3 Before demolition work is started, glazed sash, glazed doors and windows, etc, shall be removed. All fragile and loose fixtures shall be removed. The lath and all loose plaster shall be stripped off throughout the entire building. This is advantageous because it reduces glass breakage and also eliminates a large amount of dust producing material before more substantial parts of the buildings are removed.

10.5.4 All well openings which extend down to floor level shall be barricaded to a height of not less than one metre above the floor level. This provision shall not apply to the ground level floor.

10.5.5 All floor openings and shafts not used for material chutes shall be floored over and be enclosed with guard rails and toe boards.

10.5.6 The demolition shall always proceed systematically storey by storey in descending order. All work in the upper floor shall be completed and approved by the engineer-in-charge prior to disturbance to any supporting member on the lower floor. Demolition of the structure in sections may be permitted in exceptional cases, if proper precautions are ensured to prevent injuries to persons and damage to property.

10.6 Walls

10.6.1 While walls of sections of masonry are being demolished, it shall be ensured that they are not allowed to fall as single mass upon the floors of the building that are being demolished so as to exceed the safe carrying capacity of the floors. Overloading of floors shall be prevented by removing the accumulating debris through chutes or by other means immediately. The floor shall be inspected by the engineer-in-charge before undertaking demolition work and if the same is found to be incapable to carry the load of the debris, necessary additional precautions shall be taken so as to prevent any possible unexpected collapse of the floor.

10.6.2 Walls shall be removed part by part. Stages shall be provided for the men to work on if the walls are less than one and a half brick thick and dangerous to work by standing over them.

10.6.3 Adequate lateral bracing shall be provided for walls which are unsound. For detailed information reference may be made to good practice [7(51)].

10.7 Flooring

10.7.1 Prior to removal of masonry or concrete floor adequate support centering shall be provided.

10.7.2 When floors are being removed, no worker or person shall be allowed to work in the area, directly underneath and such area shall be barricaded to prevent access to it.

10.7.3 Planks of sufficient strength shall be provided to give workers firm support to guard against any unexpected floor collapse.

10.8 Demolition of Steel Structures

10.8.1 When a derrick is used, care shall be taken to see that the floor on which it is supported is amply strong for the loading so imposed. If necessary heavy planking shall be used to distribute the load to floor beam and girders.

10.8.2 Overloading of equipment shall not be allowed.

10.8.3 Tag lines shall be used on all materials being lowered or hoisted up and a standard signal system shall be used and the workers instructed on the signals.

10.8.4 No person shall be permitted to ride the load line.

10.8.5 No beams shall be cut until precautions have been taken to prevent it from swinging freely and possibly striking any worker or equipment or to any part of the structure being demolished.

10.8.6 All structural steel members shall be lowered from the building and shall not be allowed to drop.

10.9 Catch Platform

10.9.1 In demolition of exterior walls of multistorey structures, catch platform of sufficient strength to prevent injuries to workers below and public shall be provided, when the external walls are more than 20 m in height.

10.9.2 Such catch platform shall be constructed and maintained not more than 3 storeys below the storey from which exterior wall is being demolished. When demolition has progressed to within 3 storeys of ground level, catch platform will not be considered necessary.

10.9.3 Catch platform shall be capable of sustaining a live load of not less than 6 100 N/m².

10.9.4 Materials shall not be dumped on the catch platform nor shall they be used for storage of materials.

10.10 Stairs, Passageways and Ladders

10.10.1 Stairs with railings, passageways and ladders shall be left in place as long as possible and maintained in a safe condition.

10.10.2 All ladders shall be secured against, slipping out at the bottom and against movement in any direction at the top.

10.11 Mechanical Demolition

When demolition is to be performed by mechanical devices, such as weight ball and power shovels, the following additional precautions may be observed:

- a) The area shall be barricaded for a minimum distance of 1½ times the height of the wall;
- b) While the mechanical device is in operation, no worker shall be allowed to enter the building being demolished;
- c) The device shall be so located as to avoid falling debris; and
- d) The mechanical device, when being used, shall not cause any damage to adjacent structure, power line, etc.

10.12 Demolition of Certain Special Types and Elements of Structures

10.12.1 Roof Trusses

If a building has a pitched roof, the structure should be removed to wall plate level by hand methods. Sufficient purlins and bracing should be retained to ensure stability of the remaining roof trusses while each individual truss is removed progressively.

10.12.1.1 Temporary bracing should be added, where necessary, to maintain stability. The end frame opposite to the end where dismantling is commenced, or a convenient intermediate frame should be independently and securely guyed in both directions before work starts.

10.12.1.2 On no account should the bottom tie of roof trusses be cut until the principal rafters are prevented from making outward movement.

10.12.1.3 Adequate hoisting gears suitable for the loads shall be provided. If during demolition any thing is to be put on the floor below the level of the truss, it shall be ensured that the floor is capable of taking the load.

10.12.2 Heavy Floor Beams

Heavy baulks of timber and steel beams should be supported before cutting at the extremities and should then be lowered gently to a safe working place.

10.12.3 Jack Arches

Where tie rods are present between main supporting beams, these should not be cut until after the arch or series of arches in the floor have been removed. The floor should be demolished in strips parallel to the span of the arch rings (at right angles to the main floor beams).

10.12.4 Brick Arches

Expert advice should be obtained and, at all stages of the demolition, the closest supervision should be given

by persons fully experienced and conversant in the type of work to ensure that the structure is stable at all times.

However, the following points may be kept in view:

- a) On no account should the restraining influence of the abutments be removed before the dead load of the spandrel fill and the arch rings are removed.
- b) A single span arch can be demolished by hand by cutting narrow segments progressively from each springing parallel to the span of the arch, until the width of the arch has been reduced to a minimum which can then be collapsed.
- c) Where deliberate collapse is feasible, the crown may be broken by the demolition ball method working progressively from edges to the centre.
- d) Collapse of the structure can be affected in one action by the use of explosives. Charges should be inserted into bore holes drilled in both arch and abutments.
- e) In multi-span arches, before individual arches are removed, lateral restraint should be provided at the springing level. Demolition may then proceed as for single span; where explosives are used it is preferable to ensure the collapse of the whole structure in one operation to obviate the chance of leaving unstable portion standing.

10.12.5 Cantilever (Not Part of a Framed Structure)

Canopies, cornices, staircases and balconies should be demolished or supported before tailing down load is removed.

10.12.6 In-situ Reinforced Concrete

Before commencing demolition, the nature and condition of the concrete, the condition and position of reinforcement, and the possibility of lack of continuity of reinforcement should be ascertained.

Demolition should be commenced by removing partitions and external non-load bearing cladding.

10.12.6.1 Reinforced concrete beams

A supporting rope should be attached to the beam. Then the concrete should be removed from both ends by pneumatic drill and the reinforcement exposed. The reinforcement should then be cut in such a way as to allow the beam to be lowered under control to the floor.

10.12.6.2 Reinforced concrete columns

The reinforcement should be exposed at the base after restraining wire guy ropes have been placed round the member at the top. The reinforcement should then be

cut in such a way as to allow it to be pulled down to the floor under control.

10.12.6.3 Reinforced concrete walls

These should be cut into strips and demolished as for columns.

10.12.6.4 Suspended floors and roofs

The slab should be cut into strips parallel to the main reinforcement and demolished strip by strip. Where ribbed construction has been used, the principle of design and method of construction should be determined before demolition is commenced. Care should be taken not to cut the ribs inadvertently.

10.12.7 Precast Reinforced Concrete

Due precautions shall be taken to avoid toppling over of prefabricated units or any other part of the structure and whenever necessary temporary supports shall be provided.

10.12.8 Prestressed Reinforced Concrete

Before commencing of the demolition work, advice of an engineering expert in such demolition shall be obtained and followed.

10.13 Lowering, Removal and Disposal of Materials

10.13.1 Dismantled materials may be thrown to the ground only after taking adequate precautions. The material shall preferably be dumped inside the building. Normally such materials shall be lowered to the ground or to the top of the sidewalk shed where provided by means of ropes or suitable tackles.

10.13.2 Through Chutes

10.13.2.1 Wooden or metal chutes may be provided for removal of materials. The chutes shall preferably be provided at the centre of the building for efficient disposal of debris.

10.13.2.2 Chutes, if provided at an angle of more than 45° from the horizontal, shall be entirely enclosed on all the four sides, except for opening at or about the floor level for receiving the materials.

10.13.2.3 To prevent the descending material attaining a dangerous speed, chute shall not extend in an unbroken line for more than two storeys. A gate or stop shall be provided with suitable means for closing at the bottom of each chute to stop the flow of materials.

10.13.2.4 Any opening into which workers dump debris at the top of chute shall be guarded by a substantial guard rail extending at least one metre above the level of the floor or other surface on which men stand to dump the materials into the chute.

10.13.2.5 A toe board or bumper, not less than 50 mm

thick and 150 mm high shall be provided at each chute openings, if the material is dumped from the wheel barrows. Any space between the chute and the edge of the opening in the floor through which it passes shall be solidly planked over.

10.13.3 Through Holes in the Floors

10.13.3.1 Debris may also be dropped through holes in the floor without the use of chutes. In such a case the total area of the hole cut in any intermediate floor, one which lies between floor that is being demolished and the storage floor shall not exceed 25 percent of such floor area. It shall be ensured that the storage floor is of adequate strength to withstand the impact of the falling material.

10.13.3.2 All intermediate floor openings for passage of materials shall be completely enclosed with barricades or guard rails not less than one metre high and at a distance of not less than 1 m from the edge of general opening. No barricades or guard rails shall be removed until the storey immediately above has been demolished down to the floor line and all debris cleared from the floor.

10.13.3.3 When the cutting of a hole in an intermediate floor between the storage floor and the floor which is being demolished makes the intermediate floor or any portion of it unsafe, then such intermediate floor shall be properly shored. It shall also be ensured that the supporting walls are not kept without adequate lateral restraints.

10.13.4 Removal of Materials

10.13.4.1 As demolition work proceeds, the released serviceable materials of different types shall be separated from the unserviceable lot (hereinafter called 'Malba') at suitable time intervals and properly stocked clear of the spots where demolition work is being done.

10.13.4.2 The *Malba* obtained during demolition shall be collected in well-formed heaps at properly selected places, keeping in view safe conditions for workers in the area. The height of each *Malba* heap shall be limited to ensure its toppling over or otherwise endangering the safety of workers or passersby.

10.13.4.3 The *Malba* shall be removed from the demolition site to a location as required by the local civil authority. Depending on the space available at the demolition site, this operation of conveying *Malba* to its final disposal location may have to be carried out a number of times during the demolition work. In any case, the demolition work shall not be considered as completed and the area declared fit for further occupation till all the *Malba* has been carried to its final disposal location and the demolition areas tidied up.

10.13.4.4 Materials which are likely to cause dust nuisance or undue environmental pollution in any other way, shall be removed from the site at the earliest and till then they shall be suitably covered. Such materials shall be covered during transportation also.

10.13.4.5 Following other requirements should also be met:

- a) Glass and steel should be dumped or buried separately to prevent injury.
- b) Workman should be provided with suitable protective gears for personal safety during works, like safety helmets, boots, hand gloves, goggles, special attire, etc.
- c) Work of removal of debris should be carried out during day. In case of poor visibility artificial light may be provided.
- d) Debris should first be removed from top. Early removal from bottom or sides of dump may cause collapse of debris, causing injuries.

10.14 Miscellaneous

10.14.1 No demolition work should be carried out during night as far as possible, especially when the structure to be demolished is in an inhabited area. If such night work has to be done, additional precautions by way of additional red warning signals, working lights and watchmen, shall be provided to avoid any injury to workers and public. Demolition work shall not be carried out during storm and heavy rain.

10.14.2 Warning devices shall be installed in the area to warn the workers in case of any danger.

10.14.3 Safety devices like industrial safety helmets conforming to the accepted standards [7(28)] and goggles made of celluloid lens, shall be issued to the workers. Foreman-in-charge of the work areas shall ensure that all the workers are wearing the safety devices before commencing any work.

10.14.4 Construction sheds and tool boxes shall be so located as to protect workers from injuries from the falling debris.

10.14.5 Where there is a likelihood of injuries to hands of workers when demolishing RCC, steel structures, etc, gloves of suitable materials shall be worn by workers.

10.14.6 Sufficient protection by way of both overhead cover and screens shall be provided to prevent injuries to the workers and the public.

10.14.7 Safety belts or ropes shall be used by workers when working at higher levels.

10.14.8 Grading of Plot

When a building has been demolished and no building operation has been projected or approved, the vacant

plot shall be filled, graded and maintained in conformity to the established street grades at kerb level. The plot shall be maintained free from the accumulation of rubbish and all other unsafe and hazardous conditions which endangers the life or health of the public; and provisions shall be made to prevent the accumulation of water or damage to any foundations on the premises or the adjoining property.

10.15 First-Aid

10.15.1 A copy of all pertinent regulations and notices concerning accidents, injury and first-aid shall be prominently exhibited at the work site.

10.15.2 Depending on the scope and nature of the work, a person, qualified in first-aid shall be available at work site to render and direct first-aid to casualties. He shall maintain a list of individuals qualified to serve in first-aid work. Enough first-aid kit, including a stretcher and a cot with accessories shall be provided at site. A telephone may be provided to first-aid assistant with telephone numbers of the hospitals prominently displayed.

Complete reports of all accidents and action taken thereon shall be forwarded to the competent authorities.

SECTION 5 REPAIRS, RETROFITTING AND STRENGTHENING OF BUILDINGS

11 MAINTENANCE MANAGEMENT

Maintenance management of building is the art of preserving over a long period what has been constructed. Whereas construction stage lasts for a short period, maintenance continues for comparatively very large period during the useful life of building. Inadequate or improper maintenance adversely affects the environment in which people work, thus affecting the overall output. In the post construction stage the day to day maintenance or upkeep of the building shall certainly delay the decay of the building structure. Though the building may be designed to be very durable it needs maintenance to keep it in good condition. The maintenance management of buildings shall be done in accordance with Part 12 'Asset and Facility Management' of the Code.

12 PREVENTION OF CRACKS

12.1 Cracks in buildings are of common occurrence. A building component develops cracks whenever stress in the component exceeds its strength. Stress in a building component could be caused by externally applied forces, such as dead, imposed, wind or seismic loads, or foundation settlement or it could be induced internally due to thermal movements, moisture changes, chemical action, etc.

12.2 Cracks could be broadly classified as structural or non-structural. Structural cracks are those which are due to incorrect design, faulty construction or overloading and these may endanger the safety of a building. Extensive cracking of an RCC beam is an instance of structural cracking. Non-structural cracks are mostly due to internally induced stresses in building materials and these generally do not directly result in structural weakening. In course of time, however, sometime non-structural cracks may, because of penetration of moisture through cracks or weathering action, result in corrosion of reinforcement and thus may render the structure unsafe. Vertical cracks in a long compound wall due to shrinkage or thermal movement is an instance of non-structural cracking. Non-structural cracks, normally do not endanger the safety of a building, but may look unsightly, or may create an impression of faulty work or may give a feeling of instability. In some situations, cracks may, because of penetration of moisture through them, spoil the internal finish, thus adding to cost of maintenance. It is, therefore, necessary to adopt measures of prevention or minimization of these cracks.

12.3 For complete details on causes and prevention of non-structural cracks, reference shall be made to good practice SP 25:1984 'Handbook on causes and prevention of cracks in buildings'.

13 REPAIRS AND SEISMIC STRENGTHENING OF BUILDINGS

13.1 General Principles and Concepts

13.1.1 Non-structural/Architectural Repairs

13.1.1.1 The buildings affected by earthquake may suffer both non-structural and structural damages. Non-structural repairs may cover the damages to civil and electrical items, including the services in the building. Repairs to non-structural components need to be taken up after the structural repairs and retrofitting work are carried out. Care should be taken about the connection details of architectural components to the main structural components to ensure their stability.

13.1.1.2 Non-structural and architectural components get easily affected/ dislocated during the earthquake. These repairs involve one or more of the following:

- a) Patching up of defects such as cracks and fall of plaster;
- b) Repairing doors, windows, replacement of glass panes;
- c) Checking and repairing electric conduits/wiring;
- d) Checking and repairing gas pipes, water pipes and plumbing services;
- e) Rebuilding non-structural walls, smoke

chimneys, parapet walls, etc;

- f) Replastering of walls, as required;
- g) Rearranging disturbed roofing tiles;
- h) Relaying cracked flooring at ground level; and
- j) Redecoration – white washing, painting, etc.

The architectural repairs as stated above do not restore the original structural strength of structural components in the building and any attempt to carry out only repairs to architectural/non-structural elements, neglecting the required structural repairs, may have serious implications on the safety of the building. The damage would be more severe in the event of the building being shaken by a similar shock because original energy absorption capacity of the building would have been reduced.

13.1.2 Structural Repairs/Restoration

13.1.2.1 Prior to taking up of the structural repairs for restoration of original strength and any strengthening measures, it is necessary to conduct detailed damage assessment to determine,

- a) the structural condition of the building to decide whether a structure is amenable for repair; whether continued occupation is permitted; to decide the structure as a whole or a part require demolition, if considered dangerous;
- b) if the structure is considered amenable for repair then detailed damage assessment of the individual structural components (mapping of the crack pattern, distress location; crushed concrete, reinforcement bending/yielding, etc). Non-destructive testing techniques could be employed to determine the residual strength of the members; and
- c) to work out the details of temporary supporting arrangement of the distressed members so that they do not undergo further distress due to gravity loads.

13.1.2.2 After the assessment of the damage of individual structural elements, appropriate repair methods are to be carried out component-wise depending on the extent of damage. The restoration work may consist of the following:

- a) Removal of portions of cracked masonry walls and piers and rebuilding them in richer mortar. Use of non-shrinking mortar will be preferable.
- b) Addition of reinforcing mesh on both faces of the cracked wall, holding it to the wall through spikes or bolts and then covering it, suitably, with cement mortar or micro-concrete (maximum size of aggregate limited

to 6 mm or less as suitable), and may be with use of micro-reinforcement as fibre or ferro-cement.

- c) Injecting cement, polymer-cement mixture or epoxy materials, which are strong in tension, into the cracks in walls.
- d) The cracked reinforced concrete elements may be repaired by epoxy grouting and could be strengthened by epoxy or polymer mortar application like shotcreting, jacketing, etc.

NOTE — In mortar for masonry or plaster, fibres can be used.

13.1.3 Seismic Strengthening

The main purpose of the seismic strengthening is to upgrade the seismic resistance of a damaged building while repairing so that it becomes safer under future earthquake occurrences. This work may involve some of the following actions:

- a) Increasing the lateral strength in one or both directions by increasing column and wall areas or the number of walls and columns.
- b) Giving unity to the structure, by providing a proper connection between its resisting elements, in such a way that inertia forces generated by the vibration of the building can be transmitted to the members that have the ability to resist them. Typical important aspects are the connections between roofs or floors and walls, between intersecting walls and between walls and foundations.
- c) Eliminating features that are sources of weakness or that produce concentration of stresses in some members. Asymmetrical plan distribution of resisting members, abrupt changes of stiffness from one floor to the other, concentration of large masses and large openings in walls without a proper peripheral reinforcement are examples of defects of this kind.
- d) Avoiding the possibility of brittle modes of failure by proper reinforcement and connection of resisting members.

13.1.4 Seismic Retrofitting

Many existing buildings do not meet the seismic strength requirements of present earthquake codes due to original structural inadequacies and material degradation due to time or alterations carried out during use over the years. Their earthquake resistance can be upgraded to the level of the present day codes by appropriate seismic retrofitting techniques, such as mentioned in 13.1.3.

13.1.5 Strengthening or Retrofitting Versus Reconstruction

13.1.5.1 Replacement of damaged buildings or

existing unsafe buildings by reconstruction is, generally, avoided due to a number of reasons, the main ones among them being,

- a) higher cost than that of strengthening or retrofitting;
- b) preservation of historical architecture; and
- c) maintaining functional social and cultural environment.

In most instances, however, the relative cost of retrofitting to reconstruction cost determines the decision. As a thumb rule, if the cost of repair and seismic strengthening is less than about 50 percent of the reconstruction cost, the retrofitting is adopted. This may also require less working time and much less dislocation in the living style of the population. On the other hand reconstruction may offer the possibility of modernization of the habitat and may be preferred by well-to-do communities.

13.1.5.2 Cost wise the building construction including the seismic code provisions in the first instance, works out to be the cheaper in terms of its own safety and that of the occupants. Retrofitting an existing inadequate building may involve as much as 4 to 5 times the initial extra expenditure required on seismic resisting features. Repair and seismic strengthening of a damaged building may even be 5 to 10 times as expensive. It is, therefore, very much safe as well as cost-effective to construct earthquake resistant buildings at the initial stage itself according to the relevant seismic IS codes.

13.2 For detailed guidelines for repairs and seismic strengthening of masonry buildings, reference shall be made to good practice [7(52)].

13.3 For detailed guidelines for improving earthquake resistance of low strength masonry buildings, reference shall be made to good practice [7(53)].

13.4 For detailed guidelines for improving earthquake resistance of earthen buildings, reference shall be made to good practice [7(54)].

13.5 For detailed guidelines for seismic evaluation and strengthening of existing reinforced concrete buildings, reference shall be made to good practice [7(55)].

SECTION 6 HABITAT AND WELFARE REQUIREMENTS FOR WORKERS

14 HABITAT AND OTHER WELFARE REQUIREMENTS FOR CONSTRUCTION WORKERS

14.1 The following aspects relating to habitat and other welfare requirements for construction workers at site

shall be met with, in accordance with **14.2 to 14.16:**

- a) Habitat site selection criteria;
- b) Area requirements for the various facilities of the habitat;
- c) Design of the habitat including the construction materials;
- d) Specifications of living area, height of the rooms, windows and doors, ventilation;
- e) Specification and requirements for kitchen and other sanitary facilities, such as toilets, bathrooms, etc;
- f) Fire and safety requirements;
- g) First aid and medical requirements;
- h) Crèches;
- j) Habitat operation and maintenance;
- k) Security;
- m) Recreational facilities;
- n) Waste management;
- p) Habitat inspection and monitoring; and
- q) Other facilities.

The project authorities should, depending on size of the project, number of workers employed, location of the project, etc, provide these facilities for the workers. They should also decide the nature of facilities that should be provided at the workplace within working hours.

14.2 Habitat Site Selection Criteria

14.2.1 The criteria given in **14.2.1.1 to 14.2.1.5** shall be met while selecting habitat site for construction workers.

14.2.1.1 Workers habitat shall be located away from overhead electrical lines. If due to non-availability of space, the habitat need to be located in the proximity of electrical line, minimum clearances as given in Part 3 'Development Control Rules and General Building Requirements' of the Code shall be provided.

14.2.1.2 Workers' habitat shall be located sufficiently away from areas like sewage channels, effluent treatment plants, garbage dumping yards, etc.

14.2.1.3 The site selected shall be such that it does not get flooded during monsoon and drainage system available around the site for run-off water.

14.2.1.4 The site shall be separated from the construction site/public area by physical barrier such as fences.

14.2.1.5 Appropriate provisions shall be made for access to the site; and depending upon the location thereof, transportation of workers from their habitat to work locations.

14.3 Minimum Area Requirements

The area requirements as given in Table 1 shall be adopted in a construction workers' habitat.

For female workers and if workers' accommodation is provided for families of workers, separate sanitation facility for women with adequate privacy shall be provided as per Table 1.

Table 1 Area Requirements in Construction Workers' Habitat
(Clause 14.3)

Sl No. (1)	Description (2)	Quantity (3)
i)	Minimum floor area per person	3.6 m ²
ii)	Maximum number of persons per room	10
iii)	Minimum height of the room	2.7 m, if two tier beds are provided 3 m
iv)	Minimum area of kitchen per person	0.60 m ²
v)	Number of lavatories, <i>Min</i>	1 per 10 person
vi)	Number of bathrooms, <i>Min</i>	1 unit per 15 person
vii)	Number of urinals, <i>Min</i>	1 per 25 person

14.4 Minimum Facilities to be Provided in Rooms

Following minimum facilities shall be provided in rooms of construction workers:

- a) Adequate natural light during the day time and adequate artificial light;
- b) Adequate ventilation to ensure sufficient movement of air in all conditions of weather and climate;
- c) Lockable doors and windows, provided with mosquito screens where conditions warrant;
- d) A separate bed for each worker;
- e) Adequate furniture for each worker to secure his or her personal belongings, such as, a ventilated clothes locker which can be locked by the occupant to ensure privacy;
- f) Separate storage for work boots and other personal protection equipment to be provided depending on conditions;
- g) As far as practicable, sleeping rooms be so arranged that shifts are separated and that no workers working during the day share a room with workers on night shifts;
- h) Beds not to be arranged in tiers of more than two.

14.5 Design and Construction of the Habitat

Design and construction of the workers' habitat meeting

the requirements given in 14.2 to 14.4 shall be structurally sound and may be constructed at site or erected as prefabricated single/two storied accommodation.

14.6 Sanitary Facilities

Following sanitary facilities shall be provided at habitat for construction workers at site:

- a) Every lavatory shall be under cover and so partitioned off as to secure privacy, and shall have a proper door and fastenings.
- b) Where both male and female building workers are employed, separate sanitary facilities shall be provided for female workers. There shall be displayed outside each block of lavatories or urinals a notice containing therein 'For Men Only' or 'For Women Only', as the case may be, written in the language understood by the majority of such workers. Such notice shall also bear the figure of a man or of a woman, as the case may be.
- c) Every lavatory or urinal shall be conveniently situated and accessible to building workers at all times.
- d) Every lavatory or urinal and washing facilities shall be adequately lighted and shall be maintained in a clean and sanitary condition at all times.
- e) Every lavatory or urinal other than those connected with a flush sewage system shall comply with the requirements of the public health authorities.
- f) Water seal lavatories may be provided on the basis of community toilets or shared toilets as per the recommendation given in good practice [7(56)].
- g) Water shall be provided by means of a tap or otherwise so as to be conveniently accessible in or near every lavatory or urinal.
- h) The walls, ceilings and partitions of every lavatory or urinal shall be white-washed or colour-washed once in every period of six months.
- j) Waste water from wash areas, bathrooms and toilets shall be drained in septic tanks/soak pits and suitably disposed in municipal sewerage systems. For very large habitat, sewage treatment plant may be installed. No waste water shall be discharged to ground or other sources without proper treatment.
- k) Septic tanks/soak pits shall be located at a minimum distance of 18 m from the wells. Location of septic tank shall meet the requirements of good practice [7(57)].

14.7 Drinking Water Requirements

14.7.1 Sufficient quantity of potable water shall be made available for drinking. Drinking water shall meet the requirements of the accepted standard [7(58)] and water quality shall be monitored regularly.

14.7.2 Drinking water outlet shall be so located such that the distance to travel to nearest outlet shall not be more than 30 m. Drinking water tanks should be legibly marked 'Drinking Water' in a language understood by a majority of the workers and shall be located at least 6 m away from washing place, urinal or lavatory.

14.7.3 Sampling and testing of drinking water for checking its conformity to meet the requirements of 14.7.1 should be carried out quarterly through accredited laboratory.

14.7.4 Storage tanks shall be cleaned as part of regular maintenance procedure to prevent growth of slime and collection of sediments.

14.8 First Aid and Medical Facilities

14.8.1 First aid centre shall be established in the habitat with the required medical facilities. Trained first aiders/male nurse/doctor shall be employed in the First Aid Centre depending on the number of workers accommodated. Sufficient number of first-aid boxes shall be provided and maintained and the box shall be distinctly marked 'First-aid' and shall be equipped with specified articles.

14.8.2 An emergency vehicle shall be provided or an arrangement shall be made with an identified nearby hospital for providing ambulance for transportation of serious cases of accident or sickness of workers to the hospital promptly. Such vehicle should be maintained in good repair and should be equipped with standard facilities. The contact details, including phone numbers of such nearby hospitals shall be readily available to different managers/supervisors/first-aid facility in-charge. These phone numbers shall also be suitably displayed at site.

14.8.3 Details of all the first-aid/medical treatments shall be logged in the first aid register.

14.8.4 Lighting of 300 lux shall be maintained in the first aid centre.

14.8.5 Health check-up of all the workers shall be done at least once in six months by a registered medical practitioner.

14.8.6 The medical facilities shall meet the provisions of *Building and other Construction Workers (Regulation of Employment and Conditions of Service) Act, 1996* and rules framed thereunder.

14.9 Cooking Area

Cooking shall not be permitted in the living area. Separate designated kitchen shall be provided meeting the minimum area requirements given in 14.3. Canteen and cooking facilities should provide sufficient space for preparing food and eating, as well as conform to hygiene and safety requirements. When workers can individually cook their meals, they should be provided with a space separate from the sleeping areas. Facilities must be kept in a clean and sanitary condition.

14.10 Crèches

In every place wherein more than fifty female building workers are ordinarily employed, there shall be provided and maintained, a suitable room or rooms for the use of children under the age of six years of such female workers. Such rooms shall,

- a) provide adequate accommodation;
- b) be adequately lighted and ventilated;
- c) be maintained in a clean and sanitary condition; and
- d) be under the charge of women trained in the care of children and infants.

14.11 Habitat Operation and Maintenance

14.11.1 A detailed plan shall be prepared for the operation and maintenance of the habitat facilities. The plan shall cover all aspects of the operation, preventive and routine maintenance.

14.11.2 Qualified and experienced in-house electrical/maintenance personnel shall be present and available. A supervisor shall be appointed to supervise hygiene in the habitat facilities. Sufficient cleaners shall be employed to ensure that the buildings and sanitary facilities are always clean and hygienic.

14.11.3 Regular pest and insect control measures shall be taken up to avoid mosquito/pest breeding. This may be done through an approved agency.

14.11.4 Worker's transportation may be done with standard passenger vehicle/bus, where required.

14.12 Fire Prevention

14.12.1 Fire extinguishers shall be provided such that one should not have to travel more than 15 m distance to access a fire extinguisher.

14.12.2 Diesel generator shed and inflammable liquid storage areas shall be provided with foam type fire extinguishers and fire buckets.

14.12.3 Electrical fittings in the inflammable storage areas shall be flame proof.

14.12.4 'No Smoking' boards shall be displayed in gas cylinder and flammable liquid storage areas.

14.12.5 All the security and habitat maintenance personnel, habitat residents and site workers shall be trained on use of fire extinguishers.

14.13 Recreation

Internal and external recreational facilities may be made available depending on the number of workers to be accommodated. Reasonable access to telephone or other modes of communications, with any charges for the use of these services being reasonable in amount, shall be provided.

14.14 Security

14.14.1 Adequate number of security personnel shall be deployed. Specific security personnel shall be deployed at the main entry gate for restricting unauthorized entry and checking vehicle/material exit and entry.

14.14.2 Security staff shall receive adequate training on first aid, firefighting and emergency preparedness. Security staff shall have a good understanding about the importance of respecting workers' rights and the rights of the communities. Security staff shall have the emergency lights, torches and other accessories required to facilitate during emergency situations.

14.14.3 A minimum of 50 lux lighting shall be maintained in the roads, parking area, boundary wall and other general areas of the habitat.

14.15 Other Facilities

Other facilities like provisional stores with separate counters for vegetables, etc, may also be provided in a construction workers habitat.

Facilities like induction/initiation room may be planned as the part of habitat for awareness, education and other related work site requirements.

14.16 Habitat Inspection

Periodical inspection of the habitat shall be carried out by an identified team preferably once in a month. The team shall record their findings on the Inspection Report form and team shall also review and follow-up implementation of the suggested measures. The above periodic inspection report of the habitat should be submitted to Project-in-Charge.

14.17 Notwithstanding the requirements given in 14.1 to 14.16, all provisions given in relevant Act/Rules/Regulations as amended from time to time shall be followed; in this regard, reference shall also be made to the *Building and other Construction Workers (Regulation of Employment and Conditions of Service) Act, 1996* and the rules/regulations framed thereunder.

ANNEX A
(Clause 8.2.1)

CHECK LIST FOR STACKING AND STORAGE OF MATERIALS

Sl No.	Material/ Component	Base			Stack				Type of Cover		
		Firm Level Ground	Hard Floor	Off-Floor	Heaps	Tiers	Flat	Vertical	Open	Open but Covered	Under Shed
(1)	(2)	(3)	(4)	(5)	(6)	(7)	(8)	(9)	(10)	(11)	(12)
1.	Cement			✓		✓					✓
2.	Lime:										
	a) Quick lime		✓		✓					✓	
	b) Hydrated lime			✓		✓					✓
3.	Stones and aggregates:										
	a) Stones, aggregates, fly ash and cinder	✓			✓				✓		
	b) Veneering stones	✓				✓		✓	✓		
4.	Bricks and blocks	✓				✓			✓		
5.	Tiles:										
	a) Clay and concrete floor, wall and roof tiles	✓				✓	✓		✓		
	b) Ceramic tiles		✓			✓	✓				✓
6.	Partially pre-fabricated wall and roof components:										
	a) RC planks, prefabricated brick panels and ferro-cement panels	✓						✓	✓		
	b) Channel units, cored units and L-Panels	✓				✓			✓		
	c) Waffle units, RC joists, single tee and double tee	✓					✓		✓		
7.	Timber			✓		✓					✓
8.	Steel	✓					✓		✓		
9.	Aluminium sections		✓				✓				✓
10.	Doors, windows and ventilators		✓					✓			✓
11.	Roofing sheets:										
	a) AC	✓				✓	✓		✓		
	b) GI and aluminium sheets	✓				✓	✓			✓	
	c) Plastic sheets			✓		✓	✓				✓
12.	Boards like plywood, particle boards, fibre boards, blockboards and gypsum board			✓		✓	✓				✓

ANNEX A — (Concluded)

(1)	(2)	(3)	(4)	(5)	(6)	(7)	(8)	(9)	(10)	(11)	(12)
13.	Plastic and rubber flooring:										
	a) Sheets in rolls	✓						✓			✓
	b) Tiles	✓				✓	✓				✓
14.	Glass sheets		✓					✓			✓
15.	Glass bricks/blocks		✓			✓					✓
16.	CI, GI and AC pipes and fittings:										
	a) Pipes	✓				✓	✓		✓		
	b) CI and GI fittings		✓				✓				✓
	c) AC fittings		✓				✓		✓		
17.	Polyethylene pipes			✓		✓	✓				✓
18.	Unplasticized PVC pipes	✓				✓	✓		✓		
19.	Bitumen, road tar, asphalt, etc, in drums	✓				✓			✓		
20.	Oil paints		✓			✓					✓
21.	Sanitary appliances			✓			✓				✓

LIST OF STANDARDS

The following list records those standards which are acceptable as 'good practice' and 'accepted standards' in the fulfillment of the requirements of the Code. The latest version of a standard shall be adopted at the time of enforcement of the Code. The standards listed may be used by the Authority for conformance with the requirements of the referred clauses in the Code.

In the following list, the number appearing in the first column within parantheses indicates the number of the reference in this Part.

	<i>IS No.</i>	<i>Title</i>	<i>IS No.</i>	<i>Title</i>
			(Part 1) : 1998	Management, planning, review, reporting and termination procedures
			(Part 2) : 2006	Use of graphic techniques
			(4) 15883 (Part 6) : 2015	Guidelines for construction project management: Part 6 Scope management
			(5) 15883 (Part 7)	Guidelines for construction project management: Part 7 Procurement management (<i>under preparation</i>)
(1)	7337 : 2010	Glossary of terms in project management (<i>second revision</i>)	(6) 15883 (Part 2) : 2013	Guidelines for construction project management: Part 2 Time management
	10400 : 2013	Glossary of terms in inventory management (<i>second revision</i>)	(7) 15883 (Part 3) : 2015	Guidelines for construction project management: Part 3 Cost management
	15198 : 2014	Glossary of terms in human resource development	(8) 15883 (Part 4) : 2015	Guidelines for construction project management: Part 4 Quality management
(2)	16416 : 2016	Construction project management: Project formulation and appraisal — Guidelines	(9) 15883 (Part 8) : 2015	Guidelines for construction project management: Part 8 Risk management
(3)	14580	Use of network analysis for project management	(10) 15883 (Part 9)	Guidelines for construction

<i>IS No.</i>	<i>Title</i>	<i>IS No.</i>	<i>Title</i>
(11) 15883 (Part 10)	project management: Part 8 Communication management (<i>under preparation</i>) Guidelines for construction project management: Part 10	(Part 1) : 1982	and construction of machine foundations Foundations for reciprocating type machines (<i>second revision</i>)
(12) 15883 (Part 5) : 2013	Human resource management (<i>under preparation</i>) Guidelines for construction project management: Part 5	(Part 2) : 1980	Foundations for impact type machines (hammer foundations) (<i>first revision</i>)
(13) 15883 (Part 11)	Health and safety management Guidelines for construction project management: Part 11	(Part 3) : 1992	Foundations for rotary type machines (medium and high frequency) (<i>second revision</i>)
(14) 15883 (Part 12) : 2016	Sustainability management (<i>under preparation</i>) Guidelines for construction project management: Part 12	(Part 4) : 1979	Foundations for rotary type machines of low frequency (<i>first revision</i>)
(15) a) <i>Foundations</i>	Integration management	(Part 5) : 1987	Foundations for impact machines other than hammers forging and stamping press pig breakers (drop crusher and jolter) (<i>first revision</i>)
1080 : 1985	Code of practice for design and construction of shallow foundations on soils (other than raft, ring and shell) (<i>second revision</i>)	9456 : 1980	Code of practice for design and construction of conical and hyperbolic paraboloidal types of shell foundations
1904 : 1986	Code of practice for design and construction of foundations in soils: General requirements (<i>third revision</i>)	9556 : 1980	Code of practice for design and construction of diaphragm walls
2911	Code of practice for design and construction of pile foundations	12070 : 1987	Code of practice for design and construction of shallow foundations on rock
(Part 1/Sec 1) : 2010	Concrete piles, Section 1 Driven cast <i>in-situ</i> concrete piles (<i>second revision</i>)	13094 : 1992	Guidelines for selection of ground improvement techniques for foundation in weak soils
(Part 1/Sec 2) : 2010	Concrete piles, Section 2 Board cast <i>in-situ</i> concrete piles (<i>second revision</i>)	14593 : 1998	Design and construction of bored cast-in-situ piles founded on rocks — Guidelines
(Part 1/Sec 3) : 2010	Concrete piles, Section 3 Precast driven concrete piles (<i>second revision</i>)	15284	Design and construction for ground improvement:
(Part 1/Sec 4) : 2010	Concrete piles, Section 4 Precast concrete piles in prebored holes (<i>first revision</i>)	(Part 1) : 2003 (Part 2) : 2004	Stone columns Preconsolidation using vertical drains
(Part 2) : 1980	Timber piles (<i>first revision</i>)		
(Part 3) : 1980	Under-reamed piles (<i>first revision</i>)	b) <i>Masonry</i> <i>IS No.</i> 1597	<i>Title</i> Code of practice for construction of stone masonry
(Part 4) : 2013	Load test on piles (<i>second revision</i>)	(Part 1) : 1992	Rubble stone masonry (<i>first revision</i>)
2974	Code of practice for design		

<i>IS No.</i>	<i>Title</i>	<i>IS No.</i>	<i>Title</i>
(Part 2) : 1992	Ashlar masonry (<i>first revision</i>)	3670 : 1989	Code of practice for construction of timber floors (<i>first revision</i>)
2110 : 1980	Code of practice for <i>in-situ</i> construction of walls in buildings with soil-cement (<i>first revision</i>)	4913 : 1968	Code of practice for selection, installation and maintenance of timber doors and windows
2212 : 1991	Code of practice for brickwork (<i>first revision</i>)	4983 : 1968	Code of practice for design and construction of nail laminated timber beams
2250 : 1981	Code of practice for preparation and use of masonry mortars (<i>first revision</i>)	5390 : 1984	Code of practice for construction of timber ceilings (<i>first revision</i>)
2572 : 2005	Code of practice for construction of hollow and solid concrete block masonry (<i>first revision</i>)	11096 : 1984	Code of practice for design and construction of bolt-jointed timber construction
3630 : 1992	Code of practice for construction of non-load bearing gypsum block partitions (<i>first revision</i>)	12506 : 1988	Code of practice for improved thatching of roof with wrought and fire retardant treatment
4407 : 1967	Code of practice for reed walling	d) <i>Concrete</i>	
		<i>IS No.</i>	<i>Title</i>
4441 : 1980	Code of practice for use of silicate type chemical resistant mortars (<i>first revision</i>)	456 : 2000	Code of practice for plain and reinforced concrete (<i>fourth revision</i>)
4442 : 1980	Code of practice for use of sulphur type chemical resistant mortars (<i>first revision</i>)	457 : 1957	Code of practice for general construction of plain and reinforced concrete for dams and other massive structures
4443 : 1980	Code of practice for use of resin type chemical resistant mortars (<i>first revision</i>)	1343 : 2012	Code of practice for pre-stressed concrete (<i>second revision</i>)
6041 : 1985	Code of practice for construction of autoclaved cellular concrete block masonry (<i>first revision</i>)	2502 : 1963	Code of practice for bending and fixing of bars for concrete reinforcement
6042 : 1969	Code of practice for construction of light weight concrete block masonry (<i>first revision</i>)	2541 : 1991	Code of practice for preparation and use of lime concrete (<i>second revision</i>)
		3370	Code of practice for concrete structures for the storage of liquids:
c) <i>Timber and Bamboo</i>		(Part 1) : 2009	General requirements (<i>first revision</i>)
<i>IS No.</i>	<i>Title</i>	(Part 2) : 2009	Reinforced concrete structures (<i>first revision</i>)
1634 : 1992	Code of practice for design and constructions of wood stair for houses (<i>second revision</i>)	(Part 3) : 1967	Prestressed concrete structures
2366 : 1983	Code of practice for nail-jointed timber construction (<i>first revision</i>)	3558 : 1983	Code of practice for use of immersion vibrators for consolidating concrete (<i>first revision</i>)

<i>IS No.</i>	<i>Title</i>	<i>IS No.</i>	<i>Title</i>
4926 : 2003	Code of practice for ready-mixed concrete (<i>second revision</i>)	(Part 1) : 1989	chimneys: Mechanical aspects (<i>first revision</i>)
5817 : 1992	Code of practice for preparation and use of lime pozzolana mixture concrete in buildings and roads (<i>first revision</i>)	(Part 2) : 1989	Structural aspects (<i>first revision</i>)
7246 : 1974	Recommendations for use of table vibrators for consolidating concrete	8629 (Parts 1 to 3) : 1977	Code of practice for protection of iron and steel structures from atmospheric corrosion
7861	Code of practice for extreme weather concreting:	9077 : 1979	Code of practice of corrosion protection of steel reinforcement in RB and RCC construction
(Part 1) : 1975	Recommended practice for hot weather concreting	9172 : 1979	Recommended design practice for corrosion prevention of steel structures
(Part 2) : 1981	Recommended practice for cold weather concreting		
10262 : 2009	Guidelines for concrete mix design proportioning (<i>first revision</i>)	f) <i>Flooring and Roofing</i>	
10359 : 1982	Code of practice for manufacture and use of lime pozzolana concrete blocks for paving	658 : 1982	Code of practice for magnesium oxychloride composition floors (<i>second revision</i>)
14687 : 1999	Guidelines for falsework for concrete structures	1196 : 1978	Code of practice for laying bitumen mastic flooring (<i>second revision</i>)
e) <i>Steel</i>		1197 : 1970	Code of practice for laying of rubber floors (<i>first revision</i>)
<i>IS No.</i>	<i>Title</i>		
800 : 2007	Code of practice for general construction in steel (<i>third revision</i>)	1198 : 1982	Code of practice for laying, fixing and maintenance of linoleum floor (<i>first revision</i>)
801 : 1975	Code of practice for use of cold formed light gauge steel structural members in general building construction (<i>first revision</i>)	1443 : 1972	Code of practice for laying and finishing of cement concrete flooring tiles (<i>first revision</i>)
805 : 1968	Code of practice for use of steel in gravity water tanks	2118 : 1980	Code of practice for construction of jack-arch type of building floor or roof (<i>first revision</i>)
806 : 1968	Code of practice for use of steel tubes in general building construction (<i>first revision</i>)	2119 : 1980	Code of practice for construction of brick-cum-concrete composite (Madras terrace) floor or roof (<i>first revision</i>)
4000 : 1992	Code of practice for high strength bolts in steel structures (<i>first revision</i>)	2204 : 1962	Code of practice for construction of reinforced concrete shell roof
4180 : 1967	Code of practice for corrosion protection of light gauge steel sections used in building	2571 : 1970	Code of practice for laying in-situ cement concrete flooring (<i>first revision</i>)
6533	Code of practice for design and construction of steel		

<i>IS No.</i>	<i>Title</i>	<i>IS No.</i>	<i>Title</i>
2394 : 1984	Code of practice for application of lime plaster finish (<i>first revision</i>)		<i>in-situ</i> granolithic concrete floor topping
2395	Code of practice for painting concrete, masonry and plaster surfaces	6278 : 1971	Code of practice for white-washing and colour washing
(Part 1) : 1994	Operations and workmanship (<i>first revision</i>)	6494 : 1988	Code of practice for waterproofing of underground water reservoirs and swimming pools (<i>first revision</i>)
(Part 2) : 1994	Schedule (<i>first revision</i>)		
2402 : 1963	Code of practice for external rendered finishes	7198 : 1974	Code of practice for damp-proofing using bitumen mastic
2441 : 1984	Code of practice for fixing ceiling covering (<i>first revision</i>)	7290 : 1979	Recommendations for use of polyethylene film for waterproofing of roofs (<i>first revision</i>)
2524	Code of practice for painting of non-ferrous metals in buildings	9918 : 1981	Code of practice for in-situ waterproofing and damp-proofing treatments with glass fibre tissue reinforced bitumen
(Part 1) : 1968	Pre-treatment		
(Part 2) : 1968	Painting		
3036 : 1992	Code of practice for laying lime concrete for a waterproofed roof finish (<i>second revision</i>)	10439 : 1983	Code of practice for patent glazing
3067 : 1988	Code of practice for general design details and preparatory work for damp-proofing and waterproofing of buildings (<i>first revision</i>)	16135 : 2014	Code of practice for dry lining and partitioning using gypsum plasterboards
		16231	Code of practice of use of glass in buildings
3140 : 1965	Code of practice for painting asbestos cement building products	(Part 1) : 2016	General methodology and selection
4101	Code of practice for external facing and veneers	(Part 2) : 2016	Energy and light
(Part 1) : 1967	Stone facing	(Part 3) : 2016	Fire and loading
(Part 2) : 1967	Cement concrete facing	(Part 4) : 2014	Safety related to human impact
(Part 3) : 1985	Wall tiling and mosaics (<i>first revision</i>)		
		h) <i>Piping</i>	
4365 : 1967	Code of practice for application of bitumen mastic for waterproofing of roofs	<i>IS No.</i>	<i>Title</i>
		783 : 1985	Code of practice for laying of concrete pipes (<i>first revision</i>)
4597 : 1968	Code of practice for finishing of wood and wood based products with nitrocellulose and cold catalysed materials	3114 : 1994	Code of practice for laying of cast iron pipes (<i>second revision</i>)
		4127 : 1983	Code of practice for laying of glazed stoneware pipes (<i>first revision</i>)
4631 : 1986	Code of practice for laying of epoxy resin floor toppings (<i>first revision</i>)	5329 : 1983	Code of practice for sanitary pipe work above ground for buildings (<i>first revision</i>)
5491 : 1969	Code of practice for laying		

<i>IS No.</i>	<i>Title</i>	<i>IS No.</i>	<i>Title</i>
5822 : 1994	Code of practice for laying of welded steel pipes for water supply (<i>second revision</i>)	(Part 14) : 1984	Glazing (<i>third revision</i>)
6530 : 1972	Code of practice for laying of asbestos cement pressure pipes	(Part 15) : 1987	Paining, polishing, varnishing, etc (<i>fourth revision</i>)
7634	Code of practice for plastics pipe work for portable water supplies	(Part 16) : 1979	Laying of water and sewer lines including appurtenant items (<i>third revision</i>)
(Part 1) : 1975	Choice of materials and general recommendations	(Part 17) : 1985	Roadwork including air field pavements (<i>third revision</i>)
(Part 2) : 2012	Laying and jointing polyethylene (PE) pipes (<i>first revision</i>)	(Part 18) : 1974	Demolition and dismantling (<i>third revision</i>)
(Part 3) : 2003	Laying and jointing of unplasticized PVC pipes	(Part 19) : 1981	Water supply, plumbing and drains (<i>third revision</i>)
13916 : 1994	Code of practice for installation of glass fibre reinforced plastic piping system	(Part 20) : 1981	Laying of gas and oil pipe lines (<i>third revision</i>)
		(Part 21) : 1973	Woodwork and joinery (<i>second revision</i>)
		(Part 23) : 1988	Piling (<i>fourth revision</i>)
		(Part 24) : 1983	Well foundations (<i>third revision</i>)
		(Part 27) : 2013	Earth work done by mechanical appliances
		3861 : 2002	Method of measurement of plinth, carpet and rentable areas of buildings (<i>second revision</i>)
j) Measurements			
<i>IS No.</i>	<i>Title</i>	<i>IS No.</i>	<i>Title</i>
1200	Method of measurement of building and civil engineering works		
(Part 1) : 1992	Earthwork (<i>fourth revision</i>)		
(Part 2) : 1974	Concrete work (<i>third revision</i>)		
(Part 3) : 1976	Brickwork (<i>third revision</i>)		
(Part 4) : 1976	Stone masonry (<i>third revision</i>)		
(Part 5) : 2013	Formwork (<i>fourth revision</i>)		
(Part 6) : 1974	Refractory work (<i>second revision</i>)		
(Part 7) : 2013	Hardware (<i>third revision</i>)		
(Part 8) : 1993	Steel work and iron work (<i>fourth revision</i>)		
(Part 9) : 1973	Roof covering (including cladding) (<i>second revision</i>)		
(Part 10) : 2013	Ceiling and linings (<i>third revision</i>)		
(Part 11) : 2013	Paving, floor finishes dado and skirting (<i>fourth revision</i>)		
(Part 12) : 1976	Plastering and pointing (<i>third revision</i>)		
(Part 13) : 1994	White washing, colour washing, distempering and painting of building surfaces (<i>fifth revision</i>)		
k) Others			
<i>IS No.</i>	<i>Title</i>	<i>IS No.</i>	<i>Title</i>
1081 : 1960	Code of practice for fixing and glazing of metal (steel and aluminium) doors, windows and ventilators		
1649 : 1962	Code of practice for design and construction of flues and chimneys for domestic heating appliances		
1946 : 1961	Code of practice for use of fixing devices in walls, ceilings and floors of solid construction		
2470	Code of practice for installation of septic tanks		
(Part 1) : 1985	Design criteria and construction (<i>second revision</i>)		
(Part 2) : 1985	Secondary treatment and disposal of septic tank effluent (<i>second revision</i>)		
2527 : 1984	Code of practice for fixing rain-water gutters and down		

<i>IS No.</i>	<i>Title</i>	<i>IS No.</i>	<i>Title</i>
	pipes for roof drainage (<i>first revision</i>)	(16) 2750 : 1964	Specification for steel scaffoldings
3414 : 1968	Code of practice for design and installation of joints in buildings	14687 : 1999	Guidelines for falsework for concrete structures
3548 : 1988	Code of practice for glazing in buildings (<i>first revision</i>)	3696 (Part 1) : 1987	Safety code for scaffolds and ladders: Part 1 Scaffolds
3558 : 1983	Code of practice for use of immersion vibrators for consolidating concrete (<i>first revision</i>)	4014	Code of practice for steel tubular scaffolding
3935 : 1966	Code of practice for composite construction	(Part 1) : 1967	Definitions and materials
4326 : 2013	Code of practice for earthquake resistant design and construction of buildings (<i>third revision</i>)	(Part 2) : 2013	Safety regulations for scaffolding (<i>first revision</i>)
4913 : 1968	Code of practice for selection, installation and maintenance of timber doors and windows	(17) 6521 (Part 1) : 1972	Code of practice for design of tower cranes: Part 1 Static and rail mounted
6313	Code of practice for anti- termite measures in buildings	(18) 13558 (Part 3) : 1995	Cranes — control — layout and characteristics: Part 3 Tower cranes
(Part 1) : 1981	Constructional measures (<i>first revision</i>)	(19) 14687 : 1999	Guidelines for falsework for concrete structures
(Part 2) : 2013	Pre-constructional chemical treatment measures (<i>third revision</i>)	(20) 3764 : 1992	Safety code for excavation work (<i>first revision</i>)
(Part 3) : 2013	Treatment for existing buildings (<i>third revision</i>)	(21) 13416 (Part 5) : 1994	Recommendations for preventive measure against hazards at workplaces : Part 5 Fire protection
6924 : 1973	Code of practice for the construction of refuse chutes in multistoreyed buildings	(22) 11769 (Part 1) : 1987	Guidelines for safe use of products containing asbestos : Part 1 Asbestos cement products
7246 : 1974	Recommendation for use of table vibrators for consolidating concrete	(23) 15683 : 2006	Specification for portable fire extinguishers — Performance and construction
8147 : 1976	Code of practice for use of aluminium alloys in structures	16018 : 2012	Specification for wheeled fire extinguishers — Performance and construction
15345 : 2003	Code of practice for installation of frameless door and window shutters	(24) 2190 : 2010	Code of practice for selection, installation and maintenance of first-aid fire extinguishers (<i>fourth</i> <i>revision</i>)
15916 : 2010	Code of practice for build- ing design and erection using prefabricated concrete	(25) 8758 : 2013	Code of practice for fire precautionary measures in construction of temporary structures and pandals (<i>second revision</i>)
15917 : 2010	Code of practice for building design and erection using mixed/ composite construction	(26) 10439 : 1983	Code of practice patent glazing
		14687 : 1999	Guidelines for falsework for concrete structures

<i>IS No.</i>	<i>Title</i>	<i>IS No.</i>	<i>Title</i>
(27) 4138 : 1977	Safety code for working in compressed air (<i>first revision</i>)	(42) 13416 (Part 4) : 1994	Recommendations for preventive measure against hazards at workplaces : Part 4 Timber structure
(28) 2925 : 1984	Specification for industrial safety helmets (<i>second revision</i>)	(43) 15683 : 2006	Portable fire extinguishers — Performance and construction — Specification
(29) 2750 : 1964	Specification for steel scaffoldings	(44) 819 : 1957	Code of practice for resistance spot welding for light assemblies in mild steel
(30) 3696 (Part 1) : 1987	Safety code for scaffolds and ladders: Part 1 Scaffolds	1261 : 1959	Code of practice for seam welding in mild steel
4014 (Part 2) : 2013	Code of practice for steel tubular scaffolding: Part 2 Safety provisions for scaffolding (<i>first revision</i>)	3016 : 1982	Code of practice for fire precautions in welding and cutting operations (<i>first revision</i>)
(31) 3696 (Part 2) : 1991	Safety code for scaffolds and ladders: Part 2 Ladders	4081 : 2013	Blasting and related drilling operations — Code of Safety (<i>second revision</i>)
(32) 4912 : 1978	Safety requirements for floors and wall openings, railing and toe boards (<i>first revision</i>)	4138 : 1977	Safety code for working in compressed gas (<i>first revision</i>)
(33) 11461 : 1985	Code of practice for compressor safety	9595 : 1996	Recommendations for metal arc welding of carbon and carbon manganese steels (<i>first revision</i>)
(34) 5983 : 1980	Specification for eye-protectors (<i>first revision</i>)	10178 : 1995	Recommended procedure for CO ₂ gas shielded metal-arc welding of structural steels (<i>first revision</i>)
(35) 1179 : 1967	Specification for equipment for eye and face protection during welding (<i>first revision</i>)	(45) 3844 : 1989	Code of practice for installation and maintenance of internal fire hydrants and hose reels on premises (<i>first revision</i>)
(36) 2361 : 2002	Specification for bull-dog grips (<i>third revision</i>)	5290 : 1993	Specification for landing valves (<i>third revision</i>)
(37) 11057 : 1984	Specification for industrial safety nets	(46) 13416 (Part 2) : 1992	Recommendation for preventive measures against hazards at work places: Part 2 Fall prevention
(38) 3016 : 1982	Code of practice for fire precautions in welding and cutting operations (<i>first revision</i>)	(47) 13416 (Part 1) : 1992	Recommendation for preventive measures against hazards at work places: Part 1 Falling material hazard prevention
(39) 1084 : 2005	Specification for manila ropes (<i>fifth revision</i>)	(48) 13416 (Part 3) : 1994	Recommendation for preventive measures against hazards at work
2266 : 2002	Specification for steel wire ropes for general engineering purposes (<i>forth revision</i>)		
(40) 818 : 1968	Code of practice for safety and health requirements in electric and gas welding and cutting operations (<i>first revision</i>)		
(41) 5916 : 2013	Constructions involving use of hot bituminous materials — Code of safety		

<i>IS No.</i>	<i>Title</i>	<i>IS No.</i>	<i>Title</i>
	places: Part 3 Disposal of debris	(Part 3) : 1999	Emulsion (<i>third revision</i>)
(49) 274	Specification for shovels	2431 : 1963	Specification for steel wheel barrows (single wheel-type)
(Part 1) : 1981	General purpose shovels (<i>third revision</i>)	2438 : 1963	Specification for roller pan mixer
(Part 2) : 1981	Heat-treated shovels (<i>third revision</i>)	2505 : 1992	Specification for concrete vibrators, immersion type (General requirements) (<i>third revision</i>)
663 : 1980	Specification for adzes (<i>second revision</i>)	2506 : 1985	General requirements for screed board concrete vibrators (<i>first revision</i>)
704 : 1984	Specification for crow bars and claw bars (<i>second revision</i>)	2514 : 1963	Specification for concrete vibrating tables
841 : 1983	Specification for steel hammers (<i>second revision</i>)	2587 : 1975	Specification for pipes vices (open side type and fixed sides type) (<i>first revision</i>)
844	Specification for screw drivers	2588 : 1975	Specification for black-smith's vices (<i>first revision</i>)
(Part 2) : 1979	Dimensions (<i>second revision</i>)	2722 : 1964	Specification for portable swing weigh batchers for concrete (single and double bucket type)
(Part 3) : 1979	Dimensions for screw drivers for recessed head screws (<i>second revision</i>)	2852 : 1998	Specification for carpenters augers (<i>first revision</i>)
1630 : 1984	Specification for Mason's tools for plaster work and pointing work (<i>first revision</i>)	3066 : 1965	Specification for hot asphalt mixing plants
1759 : 1986	Specification for <i>Powrahs</i> (<i>second revision</i>)	3251 : 1965	Specification for asphalt paver finisher
1791 : 1985	Specification for batch type concrete mixers (<i>second revision</i>)	3365 : 1965	Specification for floor polishing machines
1930 : 2003	Woodworking tools — Chisels and gouges (<i>third revision</i>)	3559 : 1966	Specification for pneumatic concrete breakers
1931 : 2000	Specification for engineer's files (<i>third revision</i>)	3587 : 1986	Specification for rasps (<i>second revision</i>)
2028 : 2004	Specification for open jaw wrenches (spanners) (<i>fourth revision</i>)	3650 : 1981	Specification for combination side cutting pliers (<i>second revision</i>)
2029 : 1998	Specification for ring wrenches (spanners) (<i>fourth revision</i>)	3938 : 1983	Specification for electric wire rope hoists (<i>second revision</i>)
2030 : 1989	Specification for box spanners (<i>second revision</i>)	4003	Specification for pipe wrenches
2094	Specification for heater for bitumen (tar) and emulsion (<i>second revision</i>)	(Part 1) : 1978	General purposes (<i>first revision</i>)
(Part 1) : 1996	Specification (<i>second revision</i>)	(Part 2) : 1986	Heavy duty (<i>first revision</i>)
(Part 2) : 1999	Bitumen sprayer (<i>third revision</i>)		

<i>IS No.</i>	<i>Title</i>	<i>IS No.</i>	<i>Title</i>
4017 : 1992	Specification for carpenters squares (<i>first revision</i>)	6078 : 1986	Specification for Lineman's pliers (<i>second revision</i>)
4095 : 1991	Specification for pincers (<i>second revision</i>)	6087 : 1971	Specification for metal cutting shears
4183 : 1967	Specification for metal hand rammers	6118 : 1991	Specification for multiple slip joint pliers (<i>first revision</i>)
4184 : 1967	Specification for steel wheel barrows (with two wheels)	6149 : 1984	Specification for single ended open jaw adjustable wrenches (<i>first revision</i>)
4508 : 1992	Specification for open ended slugging wrenches (spanners) (<i>first revision</i>)	6375 : 1991	Specification for wood splitting wedges (<i>first revision</i>)
4915 : 1968	Specification for welders chipping hammer	6389 : 1998	Specification for combination wrenches with equal openings (<i>second revision</i>)
5066 : 1969	Specification for glass pliers	6428 : 1972	Specification for pile frame
5067 : 1969	Specification for fencing pliers	6430 : 1985	Specification for mobile air compressor for construction purposes (<i>first revision</i>)
5087 : 1969	Specification for wire stripping pliers	6433 : 1972	Specification for guniting equipment
5098 : 1969	Specification for cross cut and rip saws	6546 : 1989	Specification for claw hammers (<i>first revision</i>)
5123 : 1969	Specification for tenon and dovetail saws	6836 : 1973	Specification for hand snaps and set-ups for solid rivets
5169 : 1986	Specification for hack-saw frames (<i>first revision</i>)	6837 : 1973	Specification for three wheel type pipe cutter
5200 : 1998	Specification for bolt clippers (<i>first revision</i>)	6841 : 1973	Specification for wrecking bars
5658 : 1990	Specification for snipenose pliers (<i>first revision</i>)	6861 : 1973	Specification for engineers' scrapers
5663 : 1970	Specification for brick and mason's chisels	6881 : 1973	Specification for link type pipe cutters
5684 : 1970	Specification for pipe vices (chain type)	6891 : 1973	Specification for carpenter's auger bits
5697 : 1970	Specification for ripping chisels	6892 : 1973	Specification for black-smith's brick-iron
5889 : 1994	Specification for vibratory plate compactor (<i>first revision</i>)	7041 : 1973	Specification for carpenter's plain brace
5890 : 2004	Mobile hot mix asphalt plants, light duty — Requirements (<i>first revision</i>)	7042 : 1973	Specification for carpenter's ratchet brace
5891 : 1970	Specification for hand-operated concrete mixer	7077 : 1973	Specification for bending bars
5995 : 1971	Specification for pipe grip pliers	7958 : 1976	Specification for hand vices
6007 : 1971	Specification for pipe vices (hinged type)	8202 : 1999	Specification for carpenter's wooden bodied planes (<i>first revision</i>)

<i>IS No.</i>	<i>Title</i>	<i>IS No.</i>	<i>Title</i>
8671 : 1977	Specification for nail puller	(54) 13827 : 1993	Improving earthquake resistance of earthen buildings — Guidelines
(50) 7293 : 1974	Safety code for working with construction machinery	(55) 15988 : 2013	Seismic evaluation and strengthening of existing reinforced concrete buildings — Guidelines
(51) 4130 : 1991	Safety code for demolition of buildings (<i>second revision</i>)	(56) 13727 : 1993	Guidelines for requirements of cluster planning for housing
(52) 13935 : 2009	Guidelines for repair and seismic strengthening of masonry buildings (<i>first revision</i>)	(57) 2470 (Part 1) : 1985	Code of practice for installation of septic tanks: Part 1 design, criteria and construction (<i>second revision</i>)
(53) 13828 : 1993	Improving earthquake resistance of low strength masonry buildings — Guidelines	(58) 10500 : 2012	Specification for drinking water (<i>second revision</i>)

NATIONAL BUILDING CODE OF INDIA

PART 8 BUILDING SERVICES

Section 1 Lighting and Natural Ventilation

BUREAU OF INDIAN STANDARDS

C O N T E N T S

FOREWORD	... 3
1 SCOPE	... 5
2 TERMINOLOGY	... 5
3 ORIENTATION OF BUILDING	... 8
4 LIGHTING	... 11
5 VENTILATION	... 35
ANNEX A METHOD OF CALCULATING SOLAR LOAD ON VERTICAL SURFACES OF DIFFERENT ORIENTATION	... 46
ANNEX B SKY COMPONENT TABLES	... 49
LIST OF STANDARDS	... 55

FOREWORD

This Code (Part 8/Section 1) covers requirements and methods for lighting and natural ventilation of buildings.

Illumination levels for different tasks are recommended to be achieved either by daylighting or artificial lighting or a combination of both. This Section, read together with Part 8 'Building Services, Section 2 Electrical and Allied Installations' of the Code, adequately covers the illumination levels required and methods of achieving the same.

Ventilation requirements to maintain air quality and control body odours in terms of air changes per hour and to ensure thermal comfort and heat balance of body are laid for different occupancies and the methods of achieving the same by natural means are covered in this Section. The provisions on mechanical ventilation are covered in Part 8 'Building Services, Section 3 Air conditioning, Heating and Mechanical Ventilation' of the Code.

Climatic factors which normally help in deciding the orientation of the buildings to get desirable benefits of lighting and natural ventilation inside the buildings are also covered in this Section.

This Section was first published in 1970. The first revision of the Section was brought out in 1983. In the second revision, some provisions were updated based on the information given in the SP 41:1987 'Handbook on functional requirements of buildings (other than industrial buildings)'; other major changes in the last revision included rationalization of definitions and inclusion of definitions for some more terms; inclusion of climatic classification map of India based on a new criteria; updating of data on total solar radiations incident on various surfaces of buildings for summer and winter seasons; inclusion of design guidelines for natural ventilation; reference to Part 8 'Building Services, Section 3 Air Conditioning, Heating and Mechanical Ventilation' of the Code for guidelines on mechanical ventilation, was made, where these provisions were covered exhaustively; inclusion of rationalized method for estimation of desired capacity of ceiling fans and their optimum height above the floor for rooms of different sizes; incorporation of design sky illuminance values for different climatic zones of India, etc. Energy efficiency was another important aspect which was taken care of in the last revision of the Code. Accordingly, the relevant requirements for energy efficient system for lighting and natural ventilation were duly included in the concerned provisions under the Section.

As a result of experience gained on implementation of 2005 version of the Code and feedback data received, a need was felt to revise this Section. This draft revision has, therefore, been formulated to take care of these. The significant changes incorporated in this revision are:

- a) Calculation for solar load has been elaborated, and a detailed 'Method of Calculating Solar Load on Vertical Surfaces in Different Orientation' has been added in Annex A, supporting the relevant provisions.
- b) Detailed provisions on sky component calculation procedure have been included along with examples in Annex B supporting the relevant clauses.
- c) Reference to SP 41 : 1987 for obtaining coefficient utilization for determination of luminous flux has been included.
- d) Provisions relating to efficient artificial light source and luminaires have been updated.
- e) Modern lighting techniques such as LED and induction light have been included *vis-à-vis* their energy consumption.
- f) Provisions relating to photocontrols for artificial lights have been updated.
- g) Definitions and enabling provision for lighting shelves and light pipes have been included.
- h) Provisions related to thermal comfort clause have been elaborated including therein indices such as effective temperature, adaptive thermal comfort along with elaborations on tropical summer index.
- j) Design guidelines for natural ventilation have been elaborated with illustrations.
- k) Provisions related to determination of rate of ventilation, particularly on combined effect of wind and thermal actions, have been elaborated.

- m) Provision on colour rendering has been included in line with that in SP 72 : 2010 'National Lighting Code 2010'.
- n) Various other existing provisions have been updated based on the latest technical developments in the field.

The provisions of this Section are without prejudice to the various acts, rules and regulations including the *Factories Act, 1948* and rules and regulations framed thereunder.

The information contained in this Section is largely based on the following Indian Standards/Special Publications:

IS 2440 : 1975	Guide for daylighting of buildings (<i>second revision</i>)
IS 3103 : 1975	Code of practice for industrial ventilation (<i>first revision</i>)
IS 3362 : 1977	Code of practice for natural ventilation of residential buildings (<i>first revision</i>)
IS 3646 (Part 1) : 1992	Code of practice for interior illumination: Part 1 General requirements and recommendations for working interiors (<i>first revision</i>)
IS 7662 (Part 1) : 1974	Recommendations for orientation of buildings : Part 1 Non-industrial buildings
IS 11907 : 1986	Recommendations for calculation of solar radiation on buildings
SP 32 : 1986	Handbook on functional requirements of industrial buildings (lighting and ventilation)
SP 41 : 1987	Handbook on functional requirements of buildings other than industrial buildings

Provisions given in National Lighting Code, 'SP 72 : 2010' may also be referred.

The following publication has also been referred to in the formulation of this Section:

Report on energy conservation in buildings, submitted to Department of Power, Ministry of Energy by CSIR-Central Building Research Institute, Roorkee.

All standards, whether given herein above or cross-referred to in the main text of this Section, are subject to revision. The parties to agreement based on this Section are encouraged to investigate the possibility of applying the most recent editions of the standards.

For the purpose of deciding whether a particular requirement of this Section is complied with, the final value, observed or calculated, expressing the result of a test or analysis, shall be rounded off in accordance with IS 2 : 1960 'Rules for rounding off numerical values (*revised*)'. The number of significant places retained in the rounded off value should be the same as that of the specified value in this Section.

NATIONAL BUILDING CODE OF INDIA

PART 8 BUILDING SERVICES

Section 1 Lighting and Natural Ventilation

1 SCOPE

1.1 This Code (Part 8/Section 1) covers requirements and methods for lighting and natural ventilation of buildings.

1.2 The provisions in respect of lighting and ventilation in sustainable buildings are covered in Part 11 'Approach to Sustainability' of the Code which shall be used in conjunction with this Section.

1.3 For all buildings and facilities open to and used by the public, including all forms of public housing by the government/civic bodies and private developers, adequate lighting and ventilation for barrier free access and movement within and around buildings by elderly and persons with disabilities shall be ensured in accordance with 13 of Part 3 'Development Control Rules and General Building Requirements' of the Code.

2 TERMINOLOGY

For the purpose of this Section, the definitions given below shall apply.

2.1 Lighting

2.1.1 *Altitude* (θ) — The angular distance of any point of celestial sphere, measured from the horizon, on the great circle passing through the body and the zenith (see Fig. 1).

2.1.2 *Azimuth* (Φ) — The angle measured between meridians passing through the north point and the point in question (point C in Fig. 1).

2.1.3 *Brightness Ratio or Contrast* — The variations or contrast in brightness of the details of a visual task, such as white print on blackboard.

2.1.4 *Candela* (cd) — The SI unit of luminous intensity.

Candela = 1 lumen per steradian

2.1.5 *Central Field* — The area of circle around the point of fixation and its diameter, subtending an angle of about 2° at the eye. Objects within this area are most critically seen in both their details and colour.

2.1.6 *Clear Design Sky* — The distribution of luminance of such a sky is non-uniform; the horizon is brighter than the zenith, and when L_z is the brightness at zenith, the brightness at an altitude (θ) in the region away from the sun, is given by the expression:

$$L_\theta = L_z \operatorname{cosec} \theta \quad (\text{for } 15^\circ < \theta \leq 90^\circ)$$

$$L_\theta = L_z \operatorname{cosec} 15^\circ \quad (\text{for } 0^\circ \leq \theta \leq 15^\circ) = 3.8637 L_z$$

2.1.7 *Colour Rendering Index (CRI)* — Measure of the degree to which the psychophysical colour of an

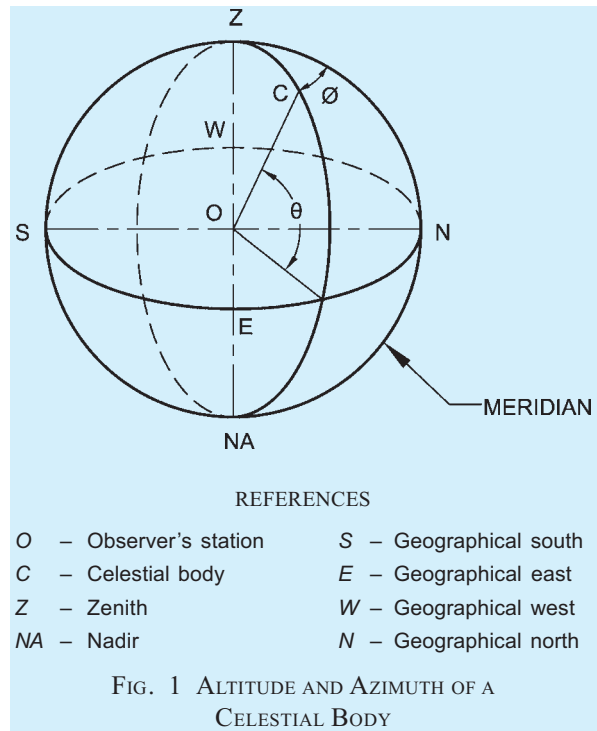

object illuminated by the test illuminant conforms to that of the same object illuminated by the reference illuminant, suitable allowance having been made for the state of chromatic adaptation.

2.1.8 *Correlated Colour Temperature (CCT) (K)* — The temperature of the Planckian radiator whose perceived colour most closely resembles that of a given stimulus at the same brightness and under specified viewing conditions.

2.1.9 *Daylight Area* — The superficial area on the working plane illuminated to not less than a specified daylight factor, that is, the area within the relevant contour.

2.1.10 *Daylight Factor* — The measure of total daylight illuminance at a point on a given plane expressed as the ratio (or percentage) which the illuminance at the point on the given plane bears to the simultaneous illuminance on a horizontal plane due to clear design sky at an exterior point open to the whole sky vault, direct sunlight being excluded.

2.1.11 *Daylight Penetration* — The maximum distance to which a given daylight factor contour penetrates into a room.

2.1.12 *Direct Solar Illuminance* — The illuminance from the sun without taking into account the light from the sky.

2.1.13 External Reflected Component (ERC) — The ratio (or percentage) of that part of the daylight illuminance at a point on a given plane which is received by direct reflection from external surfaces as compared to the simultaneous exterior illuminance on a horizontal plane from the entire hemisphere of an unobstructed clear design sky.

2.1.14 Glare — A condition of vision in which there is discomfort or a reduction in the ability to see significant objects or both due to an unsuitable distribution or range of luminance or due to extreme contrasts in space and time.

2.1.15 Illuminance — At a point on a surface, the ratio of the luminous flux incident on an infinitesimal element of the surface containing the point under consideration to the area of the element.

NOTE — The unit of illuminance (the measurement of illumination) is lux which is 1 lumen per m².

2.1.16 Internal Reflected Component (IRC) — The ratio (or percentage) of that part of the daylight illuminance at a point in a given plane which is received by direct reflection or inter-reflection from the internal surfaces as compared to the simultaneous exterior illuminance on a horizontal plane due to the entire hemisphere of an unobstructed clear design sky.

2.1.17 Light Output Ratio (LOR) or Efficiency (η) — The ratio of the luminous flux emitted from the luminaire to that emitted from the lamp(s) (nominal luminous flux). It is expressed in percent.

2.1.18 Light Pipe — A conduit made of a highly reflective material, which is capable of channeling light from one end to the other through successive internal reflections. Such a pipe may be flexible or rigid.

2.1.19 Light Shelf — A daylighting system based on sun path geometry used to bounce the light off a ceiling, project it deeper into a space, distribute it from above, and diffuse it to produce a uniform light level below.

2.1.20 Lumen (lm) — SI unit of luminous flux. The luminous flux emitted within unit solid angle (one steradian) by a point source having a uniform intensity of one candela.

2.1.21 Luminance (At a point of a Surface in a Given Direction) (Brightness) — The quotient of the luminous intensity in the given direction of an infinitesimal element of the surface containing the point under consideration by the orthogonally projected area of the element on a plane perpendicular to the given direction. The unit is candela per square metre (cd/m²).

2.1.22 Luminous Flux (ϕ) — The quantity characteristic of radiant flux which expresses its capacity to produce visual sensation evaluated according to the values of relative luminous efficiency for the light adapted eye:

- a) *Effective Luminous Flux* (ϕ_e) — Total luminous flux which reaches the working plane.
- b) *Nominal Luminous Flux* (ϕ_o) — Total luminous flux of the light sources in the interior.

2.1.23 Maintenance Factor (d) — The ratio of the average illuminance on the working plane after a certain period of use of a lighting installation to the average illuminance obtained under the same conditions for a new installation.

2.1.24 Meridian — It is the great circle passing through the zenith and nadir for a given point of observation.

2.1.25 North and South Points — The point in the respective directions where the meridian cuts the horizon.

2.1.26 Orientation of Buildings — In the case of non-square buildings, orientation refers to the direction of the normal to the long axis. For example, if the length of the building is east-west, its orientation is north-south.

2.1.27 Peripheral Field — It is the rest of the visual field which enables the observer to be aware of the spatial framework surrounding the object seen.

NOTE — A central part of the peripheral field, subtending an angle of about 30° on either side of the point of fixation, is chiefly involved in the perception of glare.

2.1.28 Reflected Glare — The variety of ill effects on visual efficiency and comfort produced by unwanted reflections in and around the task area.

2.1.29 Reflection Factor (Reflectance) — The ratio of the luminous flux reflected by a body (with or without diffusion) to the flux it receives. Some symbols used for reflection factor are:

- r_c = reflection factor of ceiling.
- r_w = reflection factor of parts of the wall between the working surface and the luminaires.
- r_f = reflection factor of floor.

2.1.30 Reveal — The side of an opening for a window.

2.1.31 Room Index (k_r) — An index relating to the shape of a rectangular interior, according to the formula:

$$k_r = \frac{LW}{(L+W)H_m}$$

where L and W are the length and width respectively of the interior, and H_m is the mounting height, that is, height of the fittings above the working plane.

NOTES

1 For rooms where the length exceeds 5 times the width, L shall be taken as $L = 5W$.

2 If the reflection factor of the upper stretch of the walls is less than half the reflection factor of the ceiling, for indirect or for the greater part of indirect lighting, the value H_m is measured between the ceiling and the working plane.

2.1.32 Sky Component (SC) — The ratio (or percentage) of that part of the daylight illuminance at a point on a given plane which is received directly from the sky as compared to the simultaneous exterior illuminance on a horizontal plane from the entire hemisphere of an unobstructed clear design sky.

2.1.33 Solar Load — The amount of heat received into a building due to solar radiation which is affected by orientation, materials of construction and reflection of external finishes and colour.

2.1.34 Utilization Factor (Coefficient of Utilization) (μ) — The ratio of the total luminous flux which reaches the working plane (effective luminous flux, ϕ_n) to the total luminous flux of the light sources in the interior (nominal luminous flux, ϕ_o).

2.1.35 Visual Field — The visual field in the binocular which includes an area approximately 120° vertically and 160° horizontally centering on the point to which the eyes are directed. The line joining the point of fixation and the centre of the pupil of each eye is called its primary line of sight.

2.1.36 Working Plane — A horizontal plane at a level at which work will normally be done (see 4.1.4.3 and 4.1.4.4).

2.2 Ventilation

2.2.1 Air Change per Hour — The amount of air leakage into or out of a building or room in terms of the number of times the building volume or room volume exchanged.

2.2.2 Axial Flow Fan — A fan having a casing in which the air enters and leaves the impeller in a direction substantially parallel to its axis.

2.2.3 Centrifugal Fan — A fan in which the air leaves the impeller in a direction substantially at right angles to its axis.

2.2.4 Contaminants — Dusts, fumes, gases, mists, vapours and such other substances present in air that are likely to be injurious or offensive to the occupants.

2.2.5 Dilution Ventilation — Supply of outside air to reduce the airborne concentration of contaminants in the building.

2.2.6 Dry Bulb Temperature — The temperature of the air, read on a thermometer, taken in such a way so as to avoid errors due to radiation.

2.2.7 Effective Temperature (ET) — An arbitrary index which combines into a single value the effect of temperature, humidity and air movement on the sensation of warmth or cold felt by the human body and its numerical value is that of the temperature of still saturated air which would induce an identical sensation.

2.2.8 Exhaust of Air — Removal of air from a building or a room and its disposal outside by means of a mechanical device, such as a fan.

2.2.9 Fresh Air or Outside Air — Air of that quality, which meets the criteria of Table 1 and in addition shall be such that the concentration of any contaminant in the air is limited to within one-tenth the threshold limit value (TLV) of that contaminant.

NOTES

1 Where it is reasonably believed that the air of quality is not expected as indicated above, sampling and analysis shall be carried out by a competent authority having jurisdiction and if the outside air of the specified quality is not available, filtration and other treatment devices shall be used to bring its quality to or above the levels mentioned in Table 1.

Odour is to be essentially unobjectionable.

2 The above list of contaminants is not exhaustive and available special literature may be referred for data on other contaminants.

Table 1 Maximum Allowable Contaminant Concentrations for Ventilation Air
(Clause 2.2.9)

Sl No.	Contaminants	Annual Average (Arithmetic Mean)	Short Term Level (Not to Exceed More than Once a Year)	Averaging Period
(1)	(2)	$\mu\text{g}/\text{m}^3$ (3)	$\mu\text{g}/\text{m}^3$ (4)	h (2)
i)	Suspended particulates	60	150	24
ii)	Sulphur oxides	80	400	24
iii)	Carbon monoxide	20 000	30 000	8
iv)	Photochemical oxidant	100	500	1
v)	Hydrocarbons (not including methanes)	1 800	4 000	3
vi)	Nitrogen oxide	200	500	24

2.2.10 General Ventilation — Ventilation, either natural or mechanical or both, so as to improve the general environment of the building, as opposed to local exhaust ventilation for contamination control.

2.2.11 Globe Temperature — The temperature measured by a thermometer whose bulb is enclosed in a matt black painted thin copper globe of 150 mm diameter. It combines the influence of air temperature and thermal radiations received or emitted by the bounding surfaces.

2.2.12 Humidification — The process whereby the absolute humidity of the air in a building is maintained at a higher level than that of outside air or at a level higher than that which would prevail naturally.

2.2.13 Humidity, Absolute — The mass of water vapour per unit volume.

2.2.14 Humidity, Relative — The ratio of the partial pressure or density of the water vapour in the air to the saturated pressure or density, respectively of water vapour at the same temperature.

2.2.15 Local Exhaust Ventilation — Ventilation effected by exhaust of air through an exhaust appliance, such as a hood with or without fan located as closely as possible to the point at which contaminants are released, so as to capture effectively the contaminants and convey them through ducts to a safe point of discharge.

2.2.16 Make-Up Air — Outside air supplied into a building to replace the indoor air.

2.2.17 Mechanical Ventilation — Supply of outside air either by positive ventilation or by infiltration by reduction of pressure inside due to exhaust of air, or by a combination of positive ventilation and exhaust of air.

2.2.18 Natural Ventilation — Supply of outside air into a building through window or other openings due to wind outside and convection effects arising from temperature or vapour pressure differences (or both) between inside and outside of the building.

2.2.19 Positive Ventilation — The supply of outside air by means of a mechanical device, such as a fan.

2.2.20 Propeller Fan — A fan in which the air leaves the impeller in a direction substantially parallel to its axis designed to operate normally under free inlet and outlet conditions.

2.2.21 Spray-Head System — A system of atomizing water so as to introduce free moisture directly into a building.

2.2.22 Stack Effect — Convection effect arising from temperature or vapour pressure difference (or both) between outside and inside of the room and the difference of height between the outlet and inlet openings.

2.2.23 Tropical Summer Index (TSI) — The temperature of calm air at 50 percent relative humidity which imparts the same thermal sensation as the given environment.

2.2.24 Threshold Limit Value (TLV) — Refers to airborne concentration of contaminants currently accepted by the American Conference of Governmental Industrial Hygienists and represents conditions under which it is believed that nearly all occupants may be repeatedly exposed, day after day, without adverse effect.

2.2.25 Velocity, Capture — Air velocity at any point in front of the exhaust hood necessary to overcome opposing air currents and to capture the contaminants in air at that point by causing the air to flow into the exhaust hood.

2.2.26 Ventilation — Supply of outside air into, or the removal of inside air from an enclosed space.

2.2.27 Wet Bulb Temperature — The steady temperature finally given by a thermometer having its bulb covered with gauze or muslin moistened with distilled water and placed in an air stream of not less than 4.5 m/s.

3 ORIENTATION OF BUILDING

3.1 The chief aim of orientation of buildings is to provide physically and psychologically comfortable living inside the building by creating conditions which suitably and successfully ward off the undesirable effects of severe weather to a considerable extent by judicious use of the recommendations and knowledge of climatic factors.

3.2 Basic Zones

3.2.1 For the purpose of design of buildings, the country may be divided into the major climatic zones as given in Table 2, which also gives the basis of this classification.

Sl No.	Climatic Zone	Mean Monthly Maximum Temperature °C	Mean Monthly Relative Humidity Percent
(1)	(2)	(3)	(4)
i)	Hot-dry	Above 30	Below 55
ii)	Warm-humid	Above 30	Above 55
		Above 25	Above 75
iii)	Temperate	25-30	Below 75
iv)	Cold	Below 25	All values
v)	Composite		see 3.2.2

The climatic classification map of India is shown in Fig. 2.

3.2.2 Each climatic zone does not have same climate for the whole year; it has a particular season for more than six months and may experience other seasons for the remaining period. A climatic zone that does not have any season for more than six months may be called as composite zone.

3.3 Climatic Factors

From the point of view of lighting and natural ventilation, the following climatic factors influence the optimum orientation of the building:

- a) Solar radiation and temperature,
- b) Relative humidity, and
- c) Prevailing winds.

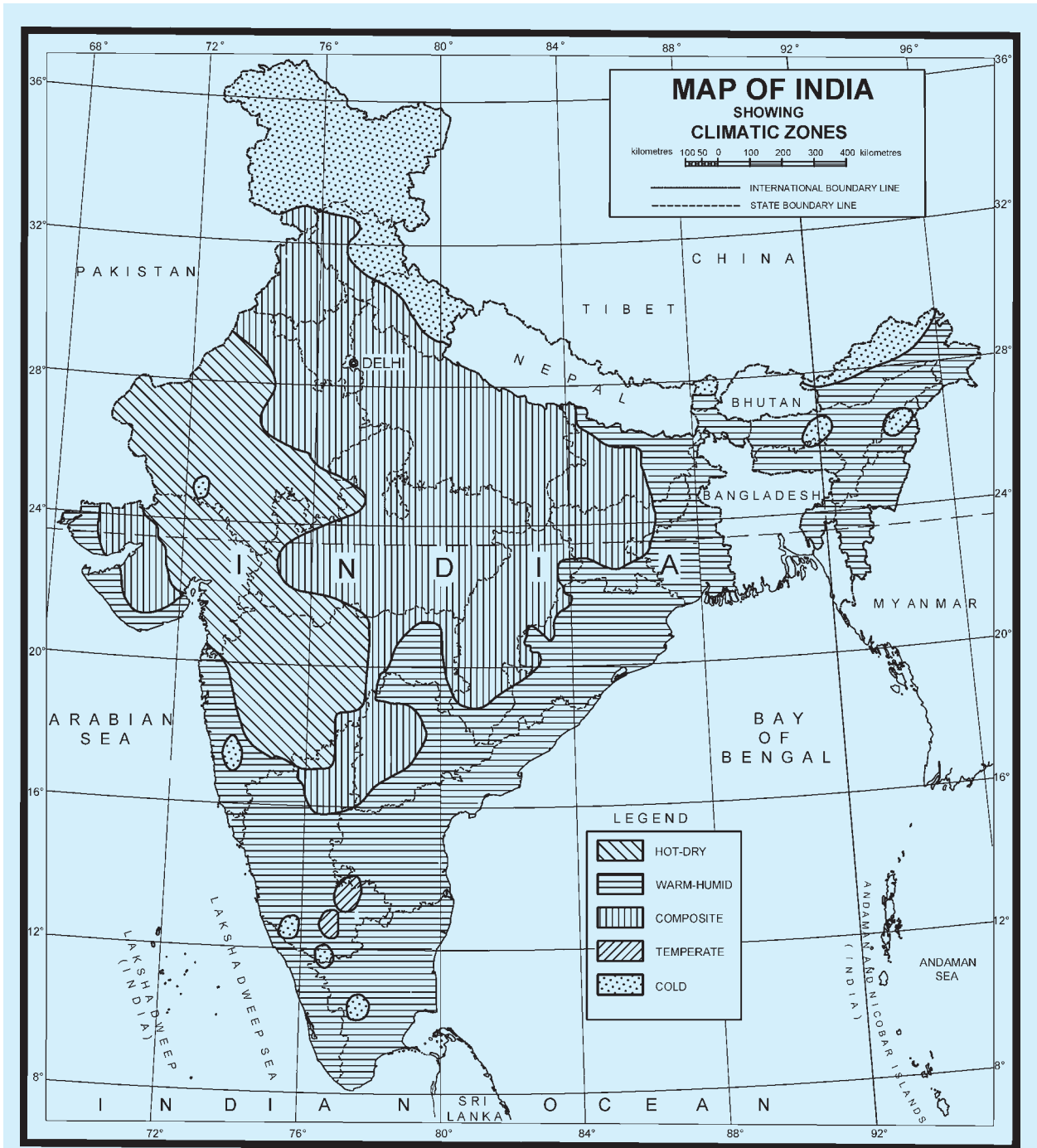

Based upon Survey of India Political map printed in 2002. © Government of India Copyright, 2016

The territorial waters of India extend into the sea to a distance of twelve nautical miles measured from the appropriate baseline.

The interstate boundaries between Arunachal Pradesh, Assam and Meghalaya shown on this map are as interpreted from the North-Eastern Areas (Reorganization) Act, 1971, but have yet to be verified.

The external boundaries and coastlines of India agree with the Record/Master Copy certified by Survey of India.

The responsibility for the correctness of internal details rest with the publisher.

FIG. 2 CLIMATIC ZONES OF INDIA

3.4 Solar Radiation

3.4.1 The best orientation from solar point of view requires that the building as a whole should receive the maximum solar radiation in winter and the minimum in summer. For practical evaluation, it is necessary to know the duration of sunshine, and hourly solar intensity on the various external surfaces on representative days of the seasons. The total direct plus diffused diurnal solar loads per unit area on vertical surface facing different directions are given in Table 3 for two days in the year, that is, 22 June and 22 December, representative of summer and winter, for latitudes corresponding to some important cities all over India. From Table 3, the total heat intake can be calculated for all possible orientations of the building for these extreme days of summer and winter. Solar load on vertical surfaces of different orientation can be calculated as per the method given in Annex A.

3.4.1.1 Except in cold climatic zone, suitable sun-breakers have to be provided to cut off the incursion of direct sunlight to prevent heat radiation and to avoid glare.

3.5 Relative Humidity and Prevailing Winds

3.5.1 The discomfort due to high relative humidity in air when temperatures are also high can be counteracted, to a great extent, by circulation of air with electric fans or by ventilation. In the past, simultaneously with heavy construction and surrounding *Verandahs* to counter the effect of sun’s radiation, there was also an over emphasis on prevailing winds to minimise the adverse effects of high humidity

with high temperatures. With the introduction of electric fan to effectively circulate air and owing to taking into account the rise in cost of construction of buildings, emphasis should be placed on protection from solar radiation where temperatures are very high. When, however, there is less diurnal variation between morning and mean maximum temperatures along with high humidity, as in coastal areas, the emphasis should be on prevailing winds.

3.5.1.1 For the purpose of orientation, it is necessary to study the velocity and direction of the wind at each hour and in each month instead of relying on generalizations of a month or a period or for the year as a whole. This helps to spot the right winds for a particular period of day or night.

3.5.1.2 It is generally found that variation up to 30° with respect to the prevalent wind direction does not materially affect indoor ventilation (average indoor air speed) inside the building.

3.5.2 In hot-dry climate, advantage can be taken of evaporative cooling in summer to cool the air before introducing it into the building. But in warm humid climate, it is desirable either to regulate the rate of air movement with the aid of electric fans or to take advantage of prevailing winds.

3.6 Aspects of Daylighting

Since the clear design sky concept for daylighting takes care of the worst possible situation, orientation is not a major problem for daylighting in buildings, except that

Table 3 Total Solar Radiation (Direct Plus Diffused) Incident on Various Surfaces of Buildings, in W/m²/day, for Summer and for Winter Seasons
(Clause 3.4.1)

Sl No.	Orientation		Latitude					
			9°N	13°N	17°N	21°N	25°N	29°N
	(1)	(2)	(3)	(4)	(5)	(6)	(7)	(8)
i)	North	Summer	1 494	1 251	2 102	1 775	2 173	1 927
		Winter	873	859	840	825	802	765
ii)	North-East	Summer	2 836	2 717	3 144	3 092	3 294	3 189
		Winter	1 240	1 158	1 068	1 001	912	835
iii)	East	Summer	3 344	3 361	3 475	3 598	3 703	3 794
		Winter	2 800	2 673	2 525	2 409	2 211	2 055
iv)	South-East	Summer	2 492	2 660	2 393	2 629	2 586	2 735
		Winter	3 936	3 980	3 980	3 995	3 892	3 818
v)	South	Summer	1 009	1 185	1 035	1 117	1 112	1 350
		Winter	4 674	4 847	4 958	5 059	4 942	4 981
vi)	South-West	Summer	2 492	2 660	2 393	2 629	2 586	2 735
		Winter	3 936	3 980	3 980	3 995	3 892	3 818
vii)	West	Summer	3 341	3 361	3 475	3 598	3 703	3 794
		Winter	2 800	2 673	2 525	2 409	2 211	2 055
viii)	North-West	Summer	2 836	2 717	3 144	3 092	3 294	3 189
		Winter	1 240	1 158	1 068	1 001	912	835
ix)	Horizontal	Summer	8 107	8 139	8 379	8 553	8 817	8 863
		Winter	6 409	6 040	5 615	5 231	4 748	4 281

direct sunshine and glare should be avoided. However, due allowance should be given to the mutual shading effects of opposite facades.

3.7 Planting of Trees

Planting of trees in streets and in open spaces should be done carefully to take advantage of both shades and sunshine without handicapping the flow of natural winds. Their advantage in abating glare and in providing cool and/or warm pockets in developed areas should also be taken. Some trees shed leaves in winter while retaining thick foliage in summer. Such trees will be very advantageous, particularly where southern and western exposures are concerned, by allowing maximum sun during winter and effectively blocking it in summer.

3.8 For detailed information regarding orientation of buildings and recommendations for various climatic zones of country, reference may be made to good practice [8-1(1)].

4 LIGHTING

4.1 Principles of Lighting

4.1.1 Aims of Good Lighting

Good lighting is necessary for all buildings and has three primary aims. The first aim is to promote work and other activities carried out within the building; the second aim is to promote the safety of the people using the building; and the third aim is to create, in conjunction with the structure and decoration, a pleasing environment conducive to interest of the occupants and a sense of their well-being.

4.1.1.1 Realization of these aims involves the following:

- a) Careful planning of the brightness and colour pattern within both the working areas and the surroundings so that attention is drawn naturally to the important areas, detail is seen quickly and accurately and the room is free from any sense of gloom or monotony (*see 4.1.4*);
- b) Using directional lighting, where appropriate, to assist perception of task detail and to give good modeling;
- c) Controlling direct and reflected glare from light sources to eliminate visual discomfort;
- d) In artificial lighting installations, minimizing flicker from certain types of lamps and paying attention to the colour rendering properties of the light;
- e) Correlating lighting throughout the building to prevent excessive differences between adjacent areas so as to reduce the risk of accidents; and
- f) Installing emergency lighting systems, where necessary.

4.1.2 Planning the Brightness Pattern

The brightness pattern seen within an interior may be considered as composed of three main parts — the task itself, immediate background of the task and the general surroundings of walls, ceiling, floor, equipment and furnishings.

4.1.2.1 In occupations where the visual demands are small, the levels of illumination derived from a criterion of visual performance alone may be too low to satisfy the other requirements. For such situations, therefore, illuminance recommendations are based on standards of welfare, safety and amenity judged appropriate to the occupations; they are also sufficient to give these tasks brightness which ensured that the visual performance exceeds the specified minimum. Unless there are special circumstances associated with the occupation, it is recommended that the illuminance of all working areas within a building should generally be 150 lux.

4.1.2.2 Where work takes place over the whole utilizable area of room, the illumination over that area should be reasonably uniform and it is recommended that the uniformity ratio (minimum illuminance divided by average illuminance levels) should be not less than 0.7 for the working area.

4.1.2.3 When the task brightness appropriate to an occupation has been determined, the brightness of the other parts of the room should be planned to give a proper emphasis to visual comfort and interest.

A general guide for the brightness relationship within the normal field of vision should be as follows:

- | | | |
|----|---|---------|
| a) | For high task brightness (above 100 cd/m ²): | Maximum |
| | 1) Between the visual task and the adjacent areas like table tops | 3:1 |
| | 2) Between the visual task and the remote areas of the room | 10:1 |
| b) | For low and medium task brightness (below 100 cd/m ²): The task should be brighter than both the background and the surroundings; the lower the task brightness, the less critical is the relationship. | |

4.1.2.4 In case of all buildings and facilities open to and used by the public including all forms of public housing by the government/civic bodies and private developers, the requirements for visual contrast as given in 13 and Annex B of Part 3 'Development Control and Rules and General Building Requirements' of the Code shall also be complied with for ensuring visual comfort for elders and persons with disabilities.

4.1.3 Glare

Excessive contrast or abrupt and large changes in

brightness produce the effect of glare. When glare is present, the efficiency of vision is reduced and small details or subtle changes in scene cannot be perceived. It may be,

- a) direct glare due to light sources within the field of vision;
- b) reflected glare due to reflections from light sources or surfaces of excessive brightness; and
- c) veiling glare where the peripheral field is comparatively very bright.

4.1.3.1 An example of glare sources in daylighting is the view of the bright sky through a window or skylight, especially when the surrounding wall or ceiling is comparatively dark or weakly illuminated. Glare can be minimised in this case either by shielding the open sky from direct sight by louvers, external hoods or deep reveals, curtains or other shading devices or by cross lighting the surroundings to a comparable level. A gradual transition of brightness from one portion to the other within the field of vision always avoids or minimises the discomfort from glare.

For electric lamps the minimum shielding angles for lamp luminance shall not be less than the values given in the table below:

<i>Lamp Luminance</i> kcd/m ²	<i>Minimum Shielding Angle</i> Degree
1 to 20	10
20 to 50	15
50 to 500	20
≥ 500	30

The above mentioned shielding angle should not be applied to luminaires that do not appear in the field of view of a worker during usual work and/or do not give the worker any noticeable disability glare.

Table 4 also gives recommended value of quality class of direct glare limitation for different tasks. These are numbers assigned to qualitative limits of direct glare: high, medium and low quality as 1, 2 and 3, respectively. For more details reference may be made to good practice [8-1(2)].

4.1.4 Recommended Values of Illuminance

Table 4 gives recommended values of illuminance commensurate with the general standards of lighting described in this Section and related to many occupations and buildings. These are valid under most of the conditions whether the illumination is by daylighting, artificial lighting or a combination of the two. The great variety of visual tasks makes it impossible to list them all and those given should be regarded as representing types of task.

4.1.4.1 The different locations and tasks are grouped within the following four sections:

- a) Industrial buildings and process;
- b) Offices, schools and public buildings;
- c) Surgeries and hospitals; and
- d) Hotels, restaurants, shops and homes.

4.1.4.2 The illumination levels recommended in Table 4 are those to be maintained at all time on the task. As circumstances may be significantly different for different interiors used for the same application or for different conditions for the same kind of activity, a range of illuminances is recommended for each type of interior or activity instead of a single value of illuminance. Each range consists of three successive steps of the recommended scale of illuminances. They represent good practice and should be regarded as giving order of illumination commonly required rather than as having some absolute significance. For working interiors the middle value of each range represents the recommended service illuminance that would be used unless one or more of the factors mentioned below apply.

4.1.4.2.1 The higher value of the range should be used when,

- a) unusually low reflectances or contrasts are present in the task;
- b) errors are costly to rectify;
- c) visual work is critical;
- d) accuracy or higher productivity is of great importance; and
- e) visual capacity of the worker makes it necessary.

4.1.4.2.2 The lower value of the range may be used when,

- a) reflectances or contrast are unusually high;
- b) speed and accuracy is not important; and
- c) the task is executed only occasionally.

4.1.4.3 Where a visual task is required to be carried out throughout an interior, general illumination level to the recommended value on the working plane is necessary; where the precise height and location of the task are not known or cannot be easily specified, the recommended value is that on horizontal plane 850 mm above floor level.

NOTE — For an industrial task, working plane for the purpose of general illumination levels is that on a work place which is generally 750 mm above the floor level. For certain purposes, such as viewing the objects of arts, the illumination levels recommended are for the vertical plane at which the art pieces are placed.

4.1.4.4 Where the task is localized, the recommended value is that for the task only; it need not, and sometimes should not, be the general level of illumination used

throughout the interior. Some processes, such as industrial inspection process, call for lighting of specialized design, in which case the level of illumination is only one of the several factors to be taken into account.

4.1.4.5 In case of all buildings and facilities open to and used by the public, including all forms of public housing by the government/civic bodies and private developers, the minimum luminance level as given in **13** and Annex B of Part 3 'Development Control Rules and General Building Requirements' of the Code shall also be complied with for ensuring sufficient lighting for accessibility by elders and persons with disabilities.

4.1.5 Lighting for Movement About a Building

Most buildings are complexes of working areas and other areas, such as passages, corridors, stairways, lobbies and entrances. The lighting of all these areas shall be properly correlated to give safe movement within the building at all times.

In case of all buildings and facilities open to and used by the public, including all forms of public housing by the government/civic bodies and private developers, the illuminance in these areas shall comply with requirements given in **13** and Annex B of Part 3 'Development Control Rules and General Building Requirements' of the Code.

4.1.5.1 Corridors, passages and stairways

Accidents may result if people leave a well-lighted working area and pass immediately into corridors or on to stairways where the lighting is inadequate, as the time needed for adaptation to the lower level may be too long to permit obstacles or the treads of stairs to be seen sufficiently quickly. For the same reason, it is desirable that the illumination level of rooms which open off a working area should be fairly high even though the rooms may be used only occasionally.

It is important, when lighting stairways, to prevent disability from glare caused by direct sight of bright sources to emphasize the edges of the treads and to avoid confusing shadows. The same precautions should be taken in the lighting of catwalks and stairways on outdoor industrial plants.

4.1.5.2 Entrances

The problems of correctly grading the lighting within a building to allow adequate time for adaptation when passing from one area to another area are particularly acute at building entrances. These are given below:

- a) By day, people entering a building will be adapted to the very high levels of brightness usually present outdoors and there is risk of accident if entrance areas, particularly any steps, are poorly lighted. This problem may often be overcome by arranging windows to

give adequate natural lighting at the immediate entrance, grading to lower levels further inside the entrance area. Where this cannot be done, supplementary artificial lighting should be installed to raise the level of illumination to an appropriate value.

- b) At night it is desirable to light entrance halls and lobbies so that the illumination level reduces towards the exit and so that no bright fittings are in the line of sight of people leaving the building. Any entrance steps to the building should be well-lighted by correctly screened fittings.

4.1.6 Colour Rendering

The colour appearance of light and its colour rendering capability are different aspects of the light sources. A faithful reproduction of an object colour depends on the colour rendering capability of the light source. In 1965 International Commission on Illumination (CIE) developed a quantitative method of assignment of colour rendering property, and is denoted as Colour Rendering Index (CRI).

CRI is arrived at by a test by which a number of specified samples are tested under a standard or reference light source and the chromaticity coordinate are plotted on the IE triangle as given in Fig. 7 of Part 2 'Physics of Light, Section 3 Colour' of National Lighting Code 2010. The same test is repeated under the source under test and corresponding chromaticity coordinate are plotted on the same plot. The difference between the position of each sample for test and standard source is measured to scale. The general colour rendering index (Ra) is obtained by the average value for eight samples (see Fig. 8 of Part 2 'Physics of Light, Section 3 Colour' of National Lighting Code 2010). For perfect agreement of colour, the R1 value should be 100. In general:

$$Ra = 1/ (R1 + R2 + R3 + R4 ++ R8)$$

The specific colour rendering index for an individual sample is given by:

$$Ri = 100 - 4.6\Delta Ei$$

where

ΔEi = chromaticity shift on the CIE chromaticity diagram for each sample.

From the obtained value of Ra, as calculated above, the colour rendering shall be evaluated as mentioned in the following table:

<i>Colour Rendering Evaluated</i>	<i>Ra (General Colour Rendering Index)</i>
True	90 - 100
Good	70 - 90
Moderate	50 - 70

Table 4 Recommended Values of Illuminance
(Clauses 4.1.3.1, 4.1.4, 4.1.4.2, 4.3.2 and 4.3.2.1)

Sl No.	Type of Interior or Activity	Range of Service Illuminance (See Note) lux	Quality Class of Direct Glare Limitation (See Note)	Remarks
(1)	(2)	(3)	(4)	(5)
1	AGRICULTURE AND HORTICULTURE			
1.1	Inspection of Farm Produce where Colour is Important	300-500-750	1	Local lighting may be appropriate
	Other Important Tasks	200-300-500	2	Local lighting may be appropriate
1.2	Farm Workshops			
1.2.1	General	50-100-150	3	
1.2.2	Workbench or machine	200-300-500	2	Local or portable lighting may be appropriate
1.3	Milk Premises	50-100-150	3	
1.4	Sick Animal Pets, Calf Nurseries	30-50-100	3	
1.5	Other Firm and Horticultural Buildings	20-30-50	3	
2	COAL MINING (SURFACE BUILDINGS)			
2.1	Coal Preparation Plant			
2.1.1	Walkways, floors under conveyors	30-50-100	3	
2.1.2	Wagon loading, bunkers	30-50-100	3	
2.1.3	Elevators, chute transfer pits, wash box area	50-100-150	3	
2.1.4	Drum filters, screen, rotating shafts	100-150-200	3	
2.1.5	Picking belts	150-200-300	3	Directional and colour properties of lighting may be important for easy recognition of coal and rock
2.2	Lamp Rooms			
2.2.1	Repair section	200-300-500	2	
2.2.2	Other areas	100-150-200	3	
2.3	Weight Cabins, Fan Houses	100-150-200	3	
2.4	Winding Houses	100-150-200	3	
3	ELECTRICITY GENERATION, TRANSMISSION AND DISTRIBUTION			
3.1	General Plant			
3.1.1	Turbine houses (operating floor)	150-200-300	2	
3.1.2	Boiler and turbine house basements	50-100-150	3	
3.1.3	Boiler houses, platforms, areas around burners	50-100-150	3	
3.1.4	Switch rooms, meter rooms, oil plant rooms, HV substations (indoor)	100-150-200	2	
3.1.5	Control rooms	200-300-500	1	Localized lighting of control display and the control desks may be appropriate
3.1.6	Relay and telecommunication rooms	200-300-500	2	
3.1.7	Diesel generator rooms, compressor rooms	100-150-200	3	
3.1.8	Pump houses, water treatment plant houses	100-150-200	3	
3.1.9	Battery rooms, chargers, rectifiers	50-100-150	3	
3.1.10	Precipitator chambers, platforms, etc	50-100-150	3	
3.1.11	Cable tunnels and basements, circulating water culverts and screen chambers, storage tanks (indoor), operating areas and filling points at outdoor tanks	30-50-100	3	
3.2	Coal Plant			
3.2.1	Conveyors, gantries, junction towers, unloading hoppers, ash handling plants, settling pits, dust hoppers outlets	50-100-150	3	
3.2.2	Other areas where operators may be in attendance	100-150-200	3	

Table 4 — (Continued)				
(1)	(2)	(3)	(4)	(5)
3.3	Nuclear Plants			
	Gas Circulation Bays, Reactor Area, Boiler Platform, Reactor Charges and Discharge Face	100-150-200	2	
4	METAL MANUFACTURE			
4.1	Iron Making			
4.1.1	Sinter plant:			
	Plant floor	150-200-300	3	
	Mixer drum, fan house, screen houses, coolers, transfer stations	100-150-200	3	
4.1.2	Furnaces, cupola:			
	General	100-150-200	3	
	Control platforms	200-300-500	2	Local lighting may be appropriate
	Conveyor galleries, walkways	30-50-100	3	
4.2	Steel Making			
4.2.1	Electric melting shops	150-200-300	3	
4.2.2	Basic oxygen steel making plants			
4.2.2.1	General	100-150-200	3	
4.2.2.2	Convertor floor, teeming bay	150-200-300	3	
4.2.2.3	Control platforms	200-300-500	2	Local lighting may be appropriate
4.2.2.4	Scrap bays	100-150-200	3	
4.3	Metal Forming and Treatment			
4.3.1	Ingot stripping, soaking pits, annealing and heat treatment bays, acid recovery plant Picking and cleaning bays, roughing mills, cold mills, finishing mills, tinning and galvanizing lines, cut up and rewind lines	150-200-300	3	
4.3.2	General	100-150-200	3	
4.3.3	Control platforms	200-300-500	2	Local lighting may be appropriate
4.3.4	Wire mills, product finishing, steel inspection and treatment	200-300-500	3	
4.3.5	Plate/strip inspection	300-500-700	2	
4.3.6	Inspection of tin plate, stainless steel, etc	—	—	Special lighting to reveal faults in the specular surface of the material will be required
4.4	Foundries			
4.4.1	Automatic plant			
4.4.1.1	Without manual operation	30-50-100	3	
4.4.1.2	With occasional manual operation	100-150-200	3	
4.4.1.3	With continuous manual operation	150-200-300	3	
4.4.1.4	Control room	200-300-500	1	Localized lighting of the control display and the control desks may be appropriate
4.4.1.5	Control platforms	200-300-500	2	
4.4.2	Non-automatic plants			
4.4.2.1	Charging floor, pouring, shaking out, cleaning, grinding fettling	200-300-500	3	
4.4.2.2	Rough moulding, rough core making	200-300-500	3	
4.4.2.3	Fine moulding, fine core making	300-500-750	2	
4.4.2.4	Inspection	300-500-750	2	
4.5	Forges (Severe vibration is likely to occur)			
4.5.1	General	200-300-500	2	
4.5.2	Inspection	300-500-750	2	
5	CERAMICS			
5.1	Concrete Products			
	Mixing, Casting, Cleaning	150-200-300	3	
5.2	Potteries			
5.2.1	Grinding, moulding, pressing, cleaning, trimming, glazing, firing	200-300-500	3	
5.2.2	Enamelling, colouring	500-750-1 000	1	
5.3	Glass Works			
5.3.1	Furnace rooms, bending, annealing	100-150-200	3	
5.3.2	Mixing rooms, forming, cutting, grinding, polishing, toughening	200-300-500	3	
5.3.3	Beveling, decorative cutting, etching, silvering	300-500-750	2	
5.3.4	Inspection	300-500-750	2	

Table 4 — (Continued)

(1)	(2)	(3)	(4)	(5)
6	CHEMICALS			
6.1	Petroleum, Chemical and Petrochemical Works			
6.1.1	Exterior walkways, platforms, stairs and ladders	30-50-100	3	
6.1.2	Exterior pump and valve areas	50-100-150	3	
6.1.3	Pump and compressor houses	100-150-200	3	
6.1.4	Process plant with remote control	30-50-100	3	
6.1.5	Process plant requiring occasional manual intervention	50-100-150	3	
6.1.6	Permanently occupied work stations in process plant	150-200-300	3	
6.1.7	Control rooms for process plant	200-300-500	1	
6.2	Pharmaceutical Manufacturer and Fine Chemicals Manufacturer			
6.2.1	Pharmaceutical manufacturer grinding, granulating, mixing, drying, tableting, sterilizing, washing, preparation of solutions, filling, capping, wrapping, hardening	300-500-750	2	
6.2.2	Fine chemical manufacture			
6.2.2.1	Exterior walkways, platforms, stairs and ladders	30-50-100	3	
6.2.2.2	Process plant	50-100-150	3	
6.2.2.3	Fine chemical finishing	300-500-750	2	
6.2.2.4	Inspection	300-500-750	1	Local lighting may be appropriate
6.3	Soap Manufacture			
6.3.1	General area	200-300-500	2	
6.3.2	Automatic processes	100-200-300	2	
6.3.3	Control panels	200-300-500	1	Local lighting may be appropriate
6.3.4	Machines	200-300-500	2	
6.4	Paint Works			
6.4.1	General	200-300-500	2	
6.4.2	Automatic processes	150-200-300	2	
6.4.3	Control panels	200-300-500	2	
6.4.4	Special batch mixing	500-750-1 000	2	
6.4.5	Colour matching	750-1 000-1 500	1	
7	MECHANICAL ENGINEERING			
7.1	Structural Steel Fabrication			
7.1.1	General	200-300-500	3	
7.1.2	Marking off	300-500-750	3	Local lighting may be appropriate
7.2	Sheet Metal Works			
7.2.1	Pressing, punching, shearing, stamping, spinning, folding	300-500-750	2	
7.2.2	Benchwork, scribing, inspection	500-750-1 000	2	
7.3	Machine and Tool Shops			
7.3.1	Rough bench and machine work	200-300-500	3	
7.3.2	Medium bench and machine work	300-500-750	2	
7.3.3	Fine bench and machine work	500-750-1 000	2	
7.3.4	Gauge rooms	750-1000-1 500	1	Optical aids may be required
7.4	Die Sinking Shops			
7.4.1	General	300-500-750	2	
7.4.2	Fine work	1 000-1 500-2 000	1	Flexible local lighting is desirable
7.5	Welding and Soldering Shops			
7.5.1	Gas and arc welding, rough spot welding	200-300-500	3	
7.5.2	Medium soldering, brazing, spot welding	300-500-750	3	
7.5.3	Fine soldering, fine spot welding	750-1 000-1 500	2	Local lighting is desirable
7.6	Assembly Shops			
7.6.1	Rough work for example, frame and heavy machine assembly	200-300-500	3	The lighting of vertical surface may be important
7.6.2	Medium work, for example, engine assembly, vehicle body assembly	300-500-750	2	
7.6.3	Fine work, for example, office machinery assembly	500-750-1 000	1	Localized lighting may be useful
7.6.4	Very fine work, for example, instrument assembly	750-1 000-1 500	1	Local lighting and optical aids are desirable
7.6.5	Minute work, for example, watch making	1 000-1 500-2 000	1	Local lighting and optical aids are desirable

Table 4 — (Continued)				
(1)	(2)	(3)	(4)	(5)
7.7	Inspection and Testing Shops			
7.7.1	Coarse work, for example, using go/no go gauges, inspection of large sub-assemblies	300-500-750	2	Local or localized lighting may be appropriate
7.7.2	Medium work, for example, inspection of painted surfaces	500-750-1 000	1	Local or localized lighting may be appropriate
7.7.3	Fine work, for example, using calibrated scales, inspection of precision mechanisms	750-1 000-1 500	1	Local or localized lighting may be appropriate
7.7.4	Very fine work, for example, inspection of small intricate parts	1 000-1 500-2 000	1	Local lighting and optical aids are desirable
7.7.5	Minute work, for example, inspection of very small instruments	2 000	1	Local lighting and optical aids are desirable
7.8	Points Shops and Spray Booths			
7.8.1	Dipping, rough spraying	200-300-500	3	
7.8.2	Preparation, ordinary painting, spraying and finishing	200-500-750	2	
7.8.3	Fine painting, spraying and finishing	500-750-1 000	2	
7.8.4	Inspection, retouching and matching	750-1 000-1 500	2	
7.9	Plating Shops			
7.9.1	Vats and baths	200-300-500	3	
7.9.2	Buffing, polishing burnishing	300-500-750	2	
7.9.3	Final buffing and polishing	500-750-1 000	2	
7.9.4	Inspection	—	—	Special light to reveal fault in the surface of the material will be required
8	ELECTRICAL AND ELECTRONIC ENGINEERING			
8.1	Electrical Equipment Manufacture			
8.1.1	Manufacture of cables and insulated wires, winding, varnishing and immersion of coils, assembly of large machines, simple assembly work	200-300-500	3	
8.1.2	Medium assembly, for example, telephones, small motors	300-500-750	3	Local lighting may be appropriate
8.1.3	Assembly of precision components, for example, telecommunication equipment, adjustment, inspection and calibration	750-1 000-1 500	1	Local lighting is desirable. Optical aids may be useful
8.1.4	Assembly of high precision parts	1 000-1 500-2 000	1	Local lighting is desirable. Optical aids may be useful
8.2	Electronic Equipment Manufacture			
8.2.1	Printed circuit board			
8.2.1.1	Silk screening	300-500-750	1	Local lighting may be appropriate
8.2.1.2	Hand insertion of components, soldering	500-750-1 000	1	Local lighting may be appropriate
8.2.1.3	Inspection	750-1 000-1 500	1	A large, low luminance luminaire overhead ensures specular reflection conditions which are helpful for inspection of printed circuits
8.2.1.4	Assembly of wiring harness, cleating harness, testing and calibration	500-750-1 000	1	Local lighting may be appropriated.
8.2.1.5	Chassis assembly	750-1 000-1 500	1	Local lighting may be appropriated.
8.2.2	Inspection and testing			
8.2.2.1	Soak test	150-200-300	2	
8.2.2.2	Safety and functional tests	200-300-500	2	
9	FOOD, DRINK AND TOBACCO			
9.1	Slaughter Houses			
9.1.1	General	200-300-500	3	
9.1.2	Inspection	300-500-750	2	
9.2	Canning, Preserving and Freezing			
9.2.1	Grading and sorting of raw materials	500-750-1 000	2	Lamp of colour rendering group 1A or 1B will be required, if colour judgement is required
9.2.2	Preparation	300-500-750	3	
9.2.3	Canned and bottled goods			
9.2.3.1	Retorts	200-300-500	3	
9.2.3.2	Automatic processes	150-200-300	3	
9.2.3.3	Labelling and packaging	200-300-500	3	

Table 4 — (Continued)				
(1)	(2)	(3)	(4)	(5)
9.2.4	Frozen foods			
9.2.4.1	Process area	200-300-500	3	
9.2.4.2	Packaging and storage	200-300-500	3	
9.3	Bottling, Brewing and Distilling			
9.3.1	Keg washing and handling, bottle washing	150-200-300	3	
9.3.2	Keg inspection	200-300-500	3	
9.3.3	Bottle inspection			Special lighting will be required
9.3.4	Process areas	200-300-500	3	
9.3.5	Bottle filling	500-750-1 000	3	
9.4	Edible Oils and Fats Processing			
9.4.1	Refining and blending	200-300-500	3	
9.4.2	Production	300-500-750	2	
9.5	Mills-Milling, Filtering and Packing	200-300-500	3	
9.6	Bakeries			
9.6.1	General	200-300-500	2	
9.6.2	Hand decorating, icing	300-500-750	2	
9.7	Chocolate and Confectionery Manufacture			
9.7.1	General	200-300-500	3	
9.7.2	Automatic processes	150-200-300	3	
9.7.3	Hand decoration, inspection, wrapping and packing	300-500-750	2	If accurate colour judgements are required, lamps of colour rendering group 1A or 1B are used
9.8	Tobacco Processing			
9.8.1	Material preparation, making and packing	300-500-750	2	
10	TEXTILES			
10.1	Fibre Preparation			
10.1.1	Bale breaking, washing	200-300-500	3	
10.1.2	Stock dyeing, tinting	200-300-500	3	
10.2	Yarn Manufacture			
10.2.1	Spinning, roving, winding, etc	300-500-750	2	
10.2.2	Healding (drawing in)	750-1000-750	2	
10.3	Fabric Production			
10.3.1	Knitting	300-500-750	2	
10.3.2	Weaving			
10.3.2.1	Jute and hemp	200-300-500	2	
10.3.2.2	Heavy woolens	300-500-750	1	
10.3.2.3	Medium worsteds, fine woolens, cottons	500-750-1 000	1	
10.3.2.4	Fine worsteds, fine linens, synthetics	750-1 000-1 500	1	
10.3.2.5	Mending	1 000-1 500-2 000	1	
10.3.2.6	Inspection	1 000-1 500-2 000	1	
10.4	Fabric Finishing			
10.4.1	Dyeing	200-300-500	3	
10.4.2	Calendaring, chemical treatment, etc	300-500-750	2	
10.4.3	Inspection			
10.4.3.1	'Grey' cloth	750-1 000-1 500	1	
10.4.3.2	Final	1 000-1 500-2 000	1	
10.5	Carpet Manufacture			
10.5.1	Winding, beaming	200-300-500	3	
10.5.2	Setting pattern, turving cropping, trimming, fringing, latexing and latex drying	300-500-750	2	
10.5.3	Designing, weaving, mending	500-750-1 000	2	
10.5.4	Inspection			
10.5.4.1	General	750-1 000-1 500	1	Local lighting may be appropriate
10.5.4.2	Piece dyeing	500-750-1 000	1	Local lighting may be appropriate
11	LEATHER INDUSTRY			
11.1	Leather Manufacture			
11.1.1	Cleaning, tanning and stretching, vats, cutting, fleshing, stuffing	200-300-500	3	
11.1.2	Finishing, scarfing	300-500-750	2	
11.2	Leather Working			
11.2.1	General	200-300-500	3	
11.2.2	Pressing, glazing	300-500-750	2	

Table 4 — (Continued)

(1)	(2)	(3)	(4)	(5)
11.2.3	Cutting, splitting, scarfing, sewing	500-750-1 000	2	Directional lighting may be useful.
11.2.4	Grading, matching		2	Local lighting may be appropriate
12	CLOTHING AND FOOTWEAR			
12.1	Clothing Manufacture			
12.1.1	Preparation of cloth	200-300-500	2	
12.1.2	Cutting	500-750-1 000	1	
12.1.3	Matching	500-750-1 000	1	
12.1.4	Sewing	750-1 000-1 500	1	
12.1.5	Pressing	300-500-750	2	
12.1.6	Inspection	1 000-1 500-2 000	1	Local lighting may be appropriate
12.1.7	Hand tailoring	1 000-1 500-2 000	1	Local lighting may be appropriate
12.2	Hosiery and Knitwear Manufacture			
12.2.1	Flat bed knitting machines	300-500-750	2	
12.2.2	Circular knitting machines	500-750-1000	2	
12.2.3	Lockstitch and overlocking machine	750-1 000-1 500	1	
12.2.4	Linking or running on	750-1 000-1 500	1	
12.2.5	Mending, handfinishing	1 000-1 500-3 000	-	Local lighting may be appropriate
12.2.6	Inspection	1 000-1 500-2 000	2	Local lighting may be appropriate
12.3	Glove Manufacture			
12.3.1	Sorting and grading	500-750-1 000	1	
12.3.2	Pressing, knitting, cutting	300-500-750	2	
12.3.3	Sewing	500-750-1 000	2	
12.3.4	Inspection	1 000-1 500-2 000	-	Local lighting may be appropriate
12.4	Hat Manufacture			
12.4.1	Stiffening, braiding, refining, forming, sizing, pounding, ironing	200-300-500	2	
12.4.2	Cleaning, flanging, finishing	300-500-750	2	
12.4.3	Sewing	500-750-1000	2	
12.4.4	Inspection	1 000-1 500-2 000	-	Local lighting may be appropriate
12.5	Boot and Shoe Manufacture			
12.5.1	Leather and synthetics			
12.5.2	Sorting and grading	750-1 000-1 500	1	
12.5.3	Clicking, closing	750-1 000-1 500	2	Local or localized lighting may be appropriate
12.5.4	Preparatory operations	750-1 000-1 500	2	Local or localized lighting may be appropriate
12.5.5	Cutting tables and pressure	1 000-1 500-2 000	1	Local or localized lighting may be appropriate
12.5.6	Bottom stock preparation, lasting, bottoming finishing, shoe rooms	750-1 000-1 500	1	Local or localized lighting may be appropriate
12.5.7	Rubber			
12.5.7.1	Washing, compounding, coating, drying, varnishing, vulcanizing, calendaring, cutting	200-300-500	3	
12.5.7.2	Lining, making and finishing	300-500-750	2	
13	TIMBER AND FURNITURE			
13.1	Sawmills			
13.1.1	General	150-200-300	3	
13.1.2	Head saw	300-500-750	2	Localized lighting may be appropriate
13.1.3	Grading	500-750-1 000	2	Directional lighting may be useful
13.2	Woodwork Shops			
13.2.1	Rough sawing, bench work	200-300-500	2	
13.2.2	Sizing, planing, sanding, medium machining and bench work	300-500-750	2	
13.2.3	Fine bench and machine work, fine sanding, finishing	500-750-1 000	2	Localized lighting may be appropriate
13.3	Furniture Manufacture			
13.3.1	Raw material stores	50-100-150	3	
13.3.2	Finished goods stores	100-150-200	3	
13.3.3	Wood matching and assembly, rough sawing, cutting	200-300-500	2	
13.3.4	Machining, sanding and assembly, polishing	300-500-750	2	Localized lighting may be appropriate
13.3.5	Tool room	300-500-750	2	
13.3.6	Spray booths			
13.3.6.1	Colour finishing	300-500-750	2	
13.3.6.2	Clear finishing	200-300-500	2	
13.3.7	Cabinet making			
13.3.7.1	Veneer sorting and grading	750-1 000-1 500	1	
13.3.7.2	Marquetry, pressing, patching and fitting	300-500-750	1	

Table 4 — (Continued)				
(1)	(2)	(3)	(4)	(5)
13.3.7.3	Final inspection	500-750-1 000	1	Special lighting will be required
13.4	Upholstery Manufacture			
13.4.1	Cloth inspection	1 000-1 500-2 000	1	Special lighting will be required
13.4.2	Filling, covering	300-500-750	2	
13.4.3	Slipping, cutting, sewing	500-750-1 000	2	
13.4.4	Mattress making			
13.4.5	Assembly	300-500-750	2	
13.4.6	Tape edging	750-1 000-1 500	2	Local lighting may be appropriate
14	PAPER AND PRINTING			
14.1	Paper Mills			
14.1.1	Pulp mills, preparation plants	200-300-500	3	
14.1.2	Paper and board making			
14.1.2.1	General	200-300-500	3	
14.1.2.2	Automatic process	150-200-300	3	Supplementary lighting may be necessary for maintenance work
14.1.2.3	Inspection, sorting	300-500-750	1	
14.1.3	Paper converting processes			
14.1.3.1	General	200-300-500	3	
14.1.3.2	Associated printing	300-500-750	2	
14.2	Printing Works			
14.2.1	Type foundries			
14.2.1.1	Matrix making, dressing type, hand and machine coating	200-300-500	3	
14.2.1.2	Front assembly, sorting	500-750-1 000	2	
14.2.2	Composing rooms			
14.2.2.1	Hand composing, imposition and distribution	500-750-1 000	1	
14.2.2.2	Hot metal keyboard	500-750-1 000	1	
14.2.2.3	Hot metal casting	200-300-500	2	
14.2.2.4	Photo composing keyboard or setters	300-500-750	1	
14.2.2.5	Paste up	500-750-1 000	1	
14.2.2.6	Illuminated tables – general lighting	200-300-500		Dimming may be required
14.2.2.7	Proof presses	300-500-750	2	
14.2.2.8	Proof reading	500-750-1 000	1	
14.2.3	Graphic Reproduction			
14.2.3.1	General	300-500-750	2	
14.2.3.2	Precision proofing, retouching, etching	750-1 000-1 500	1	Local lighting may be appropriate
14.2.3.3	Colour reproduction and inspection	750-1 000-1 500	1	
14.2.4	Printing machine room			
14.2.4.1	Presses	300-500-750	2	
14.2.4.2	Premake ready	300-500-750	2	
14.2.4.3	Printed sheet inspection	750-1 000-1 500	1	
14.2.5	Binding			
14.2.5.1	Folding, pasting, punching and stitching	300-500-750	2	
14.2.5.2	Cutting, assembling, embossing	500-750-1 000	2	
15	PLASTIC AND RUBBER			
15.1	Plastic Products			
15.1.1	Automatic plant			
15.1.1.1	Without manual control	30-50-100	3	
15.1.1.2	With occasional manual control	50-100-150	3	
15.1.1.3	With continuous manual control	200-300-500	3	
15.1.1.4	Control rooms	200-300-500	1	
15.1.1.5	Control platforms	200-300-500	2	Local lighting may be appropriate
15.1.2	Non-automatic plant			
15.1.2.1	Mixing, calendaring, extrusion, injection, compression and blow moulding, sheet fabrication	200-300-500	3	
15.1.2.2	Trimming, cutting, polishing, cementing	300-500-750	2	
15.1.2.3	Printing, inspection	750-1 000-1 500	1	
15.2	Rubber Products			
15.2.1	Stock preparation – plasticizing, milling	150-200-300	3	
15.2.2	Calendaring, fabric preparation, stock-cutting	300-500-750	3	

Table 4 — (Continued)				
(1)	(2)	(3)	(4)	(5)
15.2.3	Extruding, moulding	300-500-750	2	
15.2.4	Inspection	750-1 000-1 500	-	
16	DISTRIBUTION AND STORAGE			
16.1	Work Stores	100-150-200	3	Avoid glare to drivers of vehicles approaching the loading bay
16.1.1	Unpacking, sorting	150-200-300	3	Avoid glare to drivers of vehicles approaching the loading bay
16.1.2	Large item storage	50-100-150	3	Avoid glare to drivers of vehicles approaching the loading bay
16.1.3	Small item rack storage	200-300-500	3	Avoid glare to drivers of vehicles approaching the loading bay
16.1.4	Issue counter, records, storeman's desk	300-500-750	2	Local or localized lighting may be appropriate
16.2	Warehouses and Bulk Stores			
16.2.1	Storage of goods where identification requires only limited preparation of detail	50-100-150	3	
16.2.2	Storage of goods where identification requires perception of detail	100-150-200	3	
16.2.3	Automatic high bay rack stores			
16.2.3.1	Gangway	20		
16.2.3.2	Control station	150-200-300	3	
16.2.3.3	Packing and dispatch	200-300-500	3	
16.2.3.4	Loading bays	100-150-200	3	Avoid glare to drivers of vehicles approaching the loading bay
16.3	Cold Stores			
16.3.1	General	200-300-500	3	
16.3.2	Breakdown, make-up and dispatch	200-300-500	3	
16.3.3	Loading bays	100-150-200	3	Avoid glare to drivers of vehicles approaching the loading bay
17	COMMERCE			
17.1	Offices			
17.1.1	General offices	300-500-750	1	
17.1.2	Deep plan general offices	500-750-1000	1	
17.1.3	Computer work stations	300-500-750	1	
17.1.4	Conference rooms, executive offices	300-500-750	1	
17.1.5	Computer and data preparation rooms	300-500-750	1	
17.1.6	Filing rooms	200-300-500	1	
17.2	Drawing Offices			
17.2.1	General	300-500-750	1	
17.2.2	Drawing boards	500-750-1 000	1	
17.2.3	Computer aided design and drafting			Special lighting is required
17.2.4	Print rooms	200-300-500	1	
17.3	Banks and Building Societies			
17.3.1	Counter, office area	300-500-750	1	
17.3.2	Public area	200-300-500	1	
18	SERVICES			
18.1	Garages			
18.1.1	Interior parking areas	20-30-50	3	
18.1.2	General repairs, servicing, washing, polishing	200-300-500	2	
18.1.3	Workbench	300-500-750	1	Local or localized lighting may be appropriate
18.1.4	Spray booths	300-500-750	1	
18.1.5	External apron			
18.1.5.1	General	30-50-100		Care should be taken to avoid glare to drivers and neighbouring residents
18.1.5.2	Pump area (retail sales)	200-300-500		See 'Retailing'
18.2	Appliance servicing			
18.2.1	Workshop			
18.2.1.1	General	200-300-500	2	
18.2.1.2	Workbench	300-500-750	2	Localized lighting may be appropriate
18.2.1.3	Counter	200-300-500	2	Localized lighting may be appropriate
18.2.1.4	Stores	200-300-500	3	
18.3	Laundries			
18.3.1	Commercial laundries			
18.3.2	Receiving, sorting, washing, drying, ironing, despatch, dry-cleaning, bulk machine work	200-300-500	3	

Table 4 — (Continued)				
(1)	(2)	(3)	(4)	(5)
18.3.3	Head ironing, pressing, mending, spotting, inspection	300-500-750	3	
18.3.4	Launderettes	200-300-500	3	
18.4	Sewage Treatment Works			
18.4.1	Walkways	30-50-100	3	
18.4.2	Process areas	50-100-150	3	
19	RETAILING			The service illuminance should be provided on the horizontal plane of the counter. Where wall displays are used, a similar illuminance on the walls is desirable
19.1	Small Shops with Counters	300-500-750	1	
19.2	Small Self-Service Shops with Island Displays	300-500-750	1	
19.3	Super Markets, Hyper-Markets			
19.3.1	General	300-500-750	2	
19.3.2	Checkout	300-500-750	2	
19.3.3	Showroom for large objects, for example, cars, furniture	300-500-750	1	
19.3.4	Shopping precincts and arcades	100-150-200	2	
20	PLACES OF PUBLIC ASSEMBLY			
20.1	Public Rooms, Village Halls, Worship Halls	200-300-500	1	
20.2	Concert Halls, Cinemas and Theatres			
20.2.1	Foyer	150-200-300		
20.2.2	Booking office	200-300-500		Local or localized lighting may be appropriate
20.2.3	Auditorium	50-100-150		Dimming facilities will be necessary. Special lighting of the aisles is desirable
20.2.4	Dressing rooms	200-300-500		Special mirror lighting for make-up may be required
20.2.5	Projection room	100-150-200		
20.3	Churches			
20.3.1	Body of church	100-150-200	2	
20.3.2	Pulpit, lectern	200-300-500	2	Use local lighting
20.3.3	Choir stalls	200-300-500	2	Local lighting may be appropriate
20.3.4	Alter, communion table, chancel	100-150-200	2	Additional lighting to provide emphasis is desirable
20.3.5	Vestries	100-150-200	2	
20.3.6	Organ	200-300-500		
20.4	Hospitals			
20.4.1	Anaesthetic rooms			
20.4.1.1	General	200-300-500		
20.4.1.2	Local	750-1 000-1 500		
20.4.2	Consulting areas			
20.4.2.1	General	200-300-500		
20.4.2.2	Examination	750-1 000-1 500		
20.4.3	Corridors			
20.4.3.1	General	100-150-200		
20.4.4	Ward corridors			
20.4.4.1	Day, screened from bays	150-200-300		
20.4.4.2	Day, open to natural light	150-200-300		
20.4.4.3	Morning/evening	100-150-200		
20.4.4.4	Night	5-10		
20.4.5	Cubicles			
20.4.5.1	General	200-300-500		
20.4.5.2	Treatment	750-1 000-1 500		
20.4.6	Examination			
20.4.6.1	General	200-300-500		
20.4.6.2	Local inspection	750-1 000-1 500		
20.4.7	Intensive therapy			
20.4.7.1	Bad head	30-50		
20.4.7.2	Circulation between bed ends	50-100-150		
20.4.7.3	Observation	200-300-500		
20.4.7.4	Local observation	750-1 000-1 500		
20.4.7.5	Staff base (day)	200-300-500		
20.4.7.6	Staff base (night)	30		
20.4.8	Laboratories			
20.4.8.1	General	200-300-500		
20.4.8.2	Examination	300-500-750		
20.4.9	Nurses' stations			

Table 4 — (Continued)				
(1)	(2)	(3)	(4)	(5)
20.4.9.1	Morning/day/evening	200-300-500		
20.4.9.2	Night desks	30		
20.4.9.3	Night, medical trolleys	50-100-150		
20.4.10	Operating theatres			
20.4.10.1	General	300-500-750		
20.4.10.2	Local	10 000 to 50 000		Special operating lights are used.
20.4.11	Pathology departments			
20.4.11.1	General	200-300-500		
20.4.11.2	Examination	300-500-750		
20.4.11.3	Pharmacies	200-300-500		
20.4.11.4	Reception/enquiry	200-300-500		
20.4.11.5	Recovery rooms	200-300-500		
20.4.12	Ward-circulation			
20.4.12.1	Day	50-100-150		
20.4.12.2	Morning/evening	50-100-150		
20.4.12.3	Night	3-5		
20.4.13	Ward-bed head			
20.4.13.1	Morning/evening	30-50		
20.4.13.2	Reading	100-150-200		
20.4.14	Night			
20.4.14.1	Adult	0.1-1		
20.4.14.2	Pediatric	1		
20.4.14.3	Psychiatric	1-5		
20.4.14.4	Watch	5		
20.4.15	X-Ray areas			
20.4.15.1	General	150-200-300		
20.4.15.2	Diagnostic	150-200-300		
20.4.15.3	Operative	200-300-500		
20.4.15.4	Process dark room	50		
20.4.16	Surgeries			
20.4.16.1	General	200-300-500		
20.4.16.2	Waiting rooms	100-150-200		
20.4.17	Dental surgeries			
20.4.17.1	Chair	Special lighting		
20.4.17.2	Laboratories	300-500-750		
20.4.18	Consulting rooms			
20.4.18.1	General	200-300-500		
20.4.18.2	Desk	300-500-750		
20.4.18.3	Examination couch	300-500-750		
20.4.18.4	Ophthalmic wall and near-vision charts	300-500-750		
20.5	Hotels			
20.5.1	Entrance halls	50-100-150		
20.5.2	Reception, cashier's and porters' desks	200-300-500		Localized lighting may be appropriate.
20.5.3	Bars, coffee base, dining rooms, grill rooms, restaurants, lounges	50-200		The lighting should be designed to create an appropriate atmosphere
20.5.4	Cloak rooms, baggage rooms	50-100-150	3	
20.5.5	Bed rooms	30-50-100		Supplementary local lighting at the bed head, writing table should be provided
20.5.6	Bathroom	50-100-150		Supplementary local lighting near the mirror is desirable
20.5.7	Food preparation and stores, cellars, lifts and corridors			See 'General Building Areas'
20.6	Libraries			
20.6.1	Lending library			
20.6.1.1	General	200-300-500	1	
20.6.1.2	Counters	300-500-750	1	Localized lighting may be appropriate.
20.6.1.3	Bookshelves	100-150-200	2	The service illuminance should be provided on the vertical face at the bottom of the bookstack
20.6.1.4	Reading rooms	200-300-500	1	
20.6.1.5	Reading tables	200-300-500	1	Localized lighting may be appropriate
20.6.2	Catalogues			
20.6.2.1	Card	100-150-200	2	
20.6.2.2	Microfiche/Visual display units	100-150-200	2	
20.6.3	Reference libraries			
20.6.3.1	General	200-300-500	1	
20.6.3.2	Counters	300-500-750	1	Localized lighting may be appropriate.

Table 4 — (Continued)

(1)	(2)	(3)	(4)	(5)
20.6.3.3	Bookshelves	100-150-200	2	The service illuminance should be provided on a vertical surface at the foot of the bookshelves
20.6.3.4	Study tables, carrels	300-500-750	1	
20.6.3.5	Map room	200-300-500	1	
20.6.4	Display and exhibition areas			
20.6.4.1	Exhibits insensitive to light	200-300-500		
20.6.4.2	Exhibit sensitive to light, for example, pictures, prints, rare books in archives	50 to 150		
20.6.5	Library workrooms			
20.6.5.1	Book repair and binding	300-500-750	2	
20.6.5.2	Catalogue and sorting	300-500-750	2	
20.6.5.3	Remote book stores	100-150-200	3	
20.7	Museums and Art Galleries			
20.7.1	Exhibits insensitive to light	200-300-500		
20.7.2	Light sensitive exhibits, for example, oil and temper paints, undyed leather, bone, ivory, wood, etc	150		This is a maximum illuminance to be provided on the principal plane of the exhibit
20.7.3	Extremely light sensitive exhibits, for example, textiles, water colours, prints and drawings, skins, botanical specimens, etc	50		This is the maximum illuminance to be provided on the principal plane of the object
20.7.4	Conservation studies and workshops	300-500-750	1	
20.8	Sports Facilities			
	Multi-purpose sports halls	300-750		This lighting system should be sufficiently flexible to provide lighting suitable for the variety of sports and activities that take place in sports halls. Higher illuminance of 1000-2000 lux would be required for television coverage
21	EDUCATION			
21.1	Assembly Halls			
21.1.1	General	200-300-500	3	
21.1.2	Platform and stage			Special lighting to provide emphasis and to facilitate the use of the platform/ stage is desirable
21.2	Teaching Spaces			
	General	200-300-500	1	
21.3	Lecture Theatres			
21.3.1	General	200-300-500	1	
21.3.2	Demonstration benches	300-500-750	1	Localized lighting may be appropriate
21.4	Seminar Rooms	300-500-750	1	
21.5	Art Rooms	300-500-750	1	
21.6	Needlework Rooms	300-500-750	1	
21.7	Laboratories	300-500-750	1	
21.8	Libraries	200-300-500	1	
21.9	Music Rooms	200-300-500	1	
21.10	Sports Halls	200-300-500	1	
21.11	Workshops	200-300-500	1	
22	TRANSPORT			
22.1	Airports			
22.1.1	Ticket counters, checking desks, and information desks	300-500-750	2	Localized lighting may be appropriate
22.1.2	Departure lounges, other waiting areas	150-200-300	2	
22.1.3	Baggage reclaim	150-200-300	2	
22.1.4	Baggage handling	50-100-150	2	
22.1.5	Customs and immigration halls	300-500-750	2	
22.1.6	Concourse	150-200-300	2	
22.2	Railway Stations			
22.2.1	Ticket office	300-500-750	2	Localized lighting may be appropriate
22.2.2	Information office	300-500-750	2	Localized lighting over the counter may be appropriate
22.2.3	Parcels office, left			
22.2.4	Luggage office			
22.2.4.1	General	50-100-150	2	
22.2.4.2	Counter	150-200-300	2	
22.2.5	Waiting rooms	150-200-300	2	
22.2.6	Concourse	150-200-300	2	

Table 4 — (Concluded)

(1)	(2)	(3)	(4)	(5)
22.2.7	Time table	150-200-300	2	Localized lighting may be appropriate
22.2.8	Ticket barriers	150-200-300	2	Localized lighting may be appropriate
22.2.9	Platforms (covered)	30-50-100	2	Care should be taken to light and mark the edge of the platform clearly
22.2.10	Platforms (open)	20		Care should be taken to light and mark the edge of the platform clearly
22.3	Coach Stations			
22.3.1	Ticket offices	300-500-750	2	Localized lighting over the counter may be appropriate
22.3.2	Information offices	300-500-750	2	Localized lighting over the counter may be appropriate
22.3.3	Left luggage office			
22.3.3.1	General	50-100-150	3	
22.3.3.2	Counter	150-200-300	3	Localized lighting is appropriate
22.3.4	Waiting rooms	150-200-300	2	
22.3.5	Concourse	150-200-300	2	
22.3.6	Time tables	150-200-300	2	Local lighting is appropriate
22.3.7	Loading areas	100-150-200	3	
23	GENERAL BUILDING AREAS			
23.1	Entrance			
23.1.1	Entrance halls, lobbies, waiting rooms	150-200-300	2	
23.1.2	Enquiry desks	300-500-750	2	Localized lighting may be appropriate
23.1.3	Gatehouses	150-200-300	2	
23.2	Circulation Areas			
23.2.1	Lifts	50-100-150		
23.2.2	Corridors, passageways, stairs	50-100-150	2	
23.2.3	Escalators, revelators	100-150-200		
23.3	Medical and First Aid Centres			
23.3.1	Consulting rooms, treatment rooms	300-500-750	1	
23.3.2	Rest rooms	100-150-200	1	
23.3.3	Medical stores	100-150-200	2	
23.4	Staff Rooms			
23.4.1	Changing, locker and cleaners rooms, cloakrooms, lavatories	50-100-150		
23.4.2	Rest rooms	100-150-200	1	
23.5	Staff Restaurants			
23.5.1	Canteens, cafeterias, dining rooms, mess rooms	150-200-300	2	
23.5.2	Servery, vegetable preparation, washing-up area	200-300-500	2	
23.5.3	Food preparation and cooking	300-500-750	2	
23.5.4	Food stores, cellars	100-150-200	2	
23.6	Communications			
23.6.1	Switchboard rooms	200-300-500	2	
23.6.2	Telephone apparatus rooms	100-150-200	2	
23.6.3	Telex room, post room	300-500-750	2	
23.6.4	Reprographic room	200-300-500	2	
23.7	Building Services			
23.7.1	Boiler houses			
23.7.1.1	General	50-100-150	3	
23.7.1.2	Boiler front	100-150-200	3	
23.7.1.3	Boiler control room	200-300-500	2	Localized lighting of the control display and the control desk may be appropriate
23.7.1.4	Control rooms	200-300-500	2	Localized lighting of the control display and the control desk may be appropriate
23.7.1.5	Mechanical plant room	100-150-200	2	
23.7.1.6	Electrical power supply and distribution rooms	100-150-200	2	
23.7.1.7	Store rooms	50-100-150	3	
23.8	Car Parks			
23.8.1	Covered car parks			
23.8.1.1	Floors	5-20		
23.8.1.2	Ramps and corners	30		
23.8.1.3	Entrances and exits	50-100-150		
23.8.1.4	Control booths	150-200-300		
23.8.1.5	Outdoor car parks	5-20		

NOTE — For details on use of the ranges of illumination given in three steps in this table, reference shall be made to 4.1.4.2, 4.1.4.2.1 and 4.1.4.2.2. For details on quality class of direct glare limitation, reference shall be made to 4.1.3.1.

4.1.7 For detailed information regarding principles of good lighting, reference may be made to good practice [8-1(2)].

4.2 Daylighting

The primary source of lighting for daylighting is the sun. The light received by the earth from the sun consists of two parts, namely, direct solar illuminance and sky illuminance. For the purposes of daylighting design, direct solar illuminance shall not be considered and only sky illuminance shall be taken as contributing to illumination of the building interiors during the day.

4.2.1 The relative amount of sky illuminance depends on the position of the sun defined by its altitude, which in turn, varies with the latitude of the locality, the day of the year and the time of the day, as indicated in Table 5.

4.2.2 The external available horizontal sky illuminance (diffuse illuminance) values which are exceeded for about 90 percent of the daytime working hours may be taken as outdoor design illuminance values for ensuring adequacy of daylighting design. The outdoor design sky illuminance varies for different climatic regions of the country. The recommended design sky illuminance values are 6 800 lux for cold climate, 8 000 lux for composite climate, 9 000 lux for warm humid climate, 9 000 lux for temperate climate and 10 500 lux for hot-dry climate. For integration with the artificial lighting during daytime working hours an increase of 500 lux in the recommended sky design illuminance for daylighting is suggested.

4.2.3 The daylight factor is dependent on the sky luminance distribution, which varies with atmospheric conditions. A clear design sky with its non-uniform distribution of luminance is adopted for the purposes of design in this Section.

4.2.4 Components of Daylight Factor

Daylight factor is the sum of all the daylight reaching on an indoor reference point from the following sources:

- a) Direct sky visible from the point,
- b) External surfaces reflecting light directly to the point (*see* Note 1), and
- c) Internal surfaces reflecting and inter-reflecting light to the point.

NOTES

1 External surface reflection may be computed approximately only for points at the centre of the room, and for detailed analysis procedures are complicated and these may be ignored for actual calculations.

2 Each of the three components, when expressed as a ratio or percent of the simultaneous external illuminance on the

horizontal plane, defines respectively the sky component (SC), the external reflected component (ERC) and the internal reflected component (IRC) of the daylight factor.

4.2.4.1 The daylight factors on the horizontal plane only are usually taken, as the working plane in a room is generally horizontal; however, the factors in vertical planes should also be considered when specifying daylighting values for special cases, such as daylighting on classrooms, blackboards, pictures and paintings hung on walls.

4.2.5 Sky Component (SC)

Sky component for a window of any size is computed by the use of the appropriate table of Annex B.

- a) The recommended sky component level should be ensured generally on the working plane at the following positions:
 - 1) At a distance of 3 m to 3.75 m from the window along the central line perpendicular to the window,
 - 2) At the centre of the room if more appropriate, and
 - 3) At fixed locations, such as school desks, blackboards and office tables.
- b) The daylight area of the prescribed sky component should not normally be less than half the total area of the room.

4.2.5.1 The values obtainable from the tables are for rectangular, open unglazed windows, with no external obstructions. The values shall be corrected for the presence of window bars, glazing and external obstructions, if any. This assumes the maintenance of a regular cleaning schedule.

4.2.5.2 Corrections for window bars

The corrections for window bars shall be made by multiplying the values read from tables in Annex B by a factor equal to the ratio of the clear opening to the overall opening.

4.2.5.3 Correction for glazing

Where windows are glazed, the sky components obtained from Annex A shall be reduced by 10 to 20 percent, provided the panes are of clear and clean glass. Where glass is of the frosted (ground) type, the sky components read from Annex A may be reduced by 15 to 30 percent. In case of tinted or reflective glass the reduction is about 50 percent. Higher indicated correction corresponds to larger windows and/or near reference points. In the case of openings and glazings which are not vertical, suitable correction shall be taken into account.

Table 5 Solar Altitudes (to the Nearest Degree) for Indian Latitudes

(Clause 4.2.1)

Period of Year	22 June						21 March and 23 September						22 December					
	07 00	08 00	09 00	10 00	11 00	12 00	07 00	08 00	09 00	10 00	11 00	12 00	07 00	08 00	09 00	10 00	11 00	12 00
Hours of Day (Sun or Solar) Latitude	17 00	16 00	15 00	14 00	13 00	—	17 00	16 00	15 00	14 00	13 00	—	17 00	16 00	15 00	14 00	13 00	—
(1)	(2)	(3)	(4)	(5)	(6)	(7)	(8)	(9)	(10)	(11)	(12)	(13)	(14)	(15)	(16)	(17)	(18)	(19)
10°N	18	31	45	58	70	77	15	30	44	59	72	80	9	23	35	46	53	57
13°N	19	32	46	60	72	80	15	29	44	58	70	77	8	21	33	43	51	54
16°N	20	33	47	61	74	83	14	29	43	56	68	74	7	19	31	41	48	51
19°N	21	34	48	62	75	86	14	28	42	55	66	71	5	18	29	48	45	48
22°N	22	35	49	62	75	89	14	28	41	53	64	68	4	16	27	36	42	45
25°N	23	36	49	63	76	88	13	27	40	52	61	65	3	14	25	34	39	42
28°N	23	36	49	63	76	86	13	26	39	50	59	62	1	13	23	31	37	39
31°N	24	37	50	62	75	82	13	25	37	48	56	56	—	11	21	28	34	36
34°N	25	37	49	62	73	79	12	25	36	46	53	56	—	9	18	26	31	33

4.2.5.4 Correction for external obstructions

There is no separate correction, except that the values from tables in Annex B shall be read only for the unobstructed portions of the window.

4.2.6 External Reflected Component (ERC)

The value of the sky component corresponding to the portion of the window obstructed by the external obstructions may be found by the use of methods described in Annex C of good practice [8-1(3)].

These values when multiplied by the correction factors, corresponding to the mean elevation of obstruction from the point in question as given in Table 6, can be taken as the external reflected components for that point.

Table 6 Correction Factor for ERC

(Clause 4.2.6)

SI No.	Mean Angle of Elevation	Correction Factor
(1)	(2)	(3)
i)	5°	0.086
ii)	15°	0.086
iii)	25°	0.142
iv)	35°	0.192
v)	45°	0.226
vi)	55°	0.274
vii)	65°	0.304
viii)	75°	0.324
ix)	85°	0.334

4.2.6.1 For method of calculating ERC, reference may be made to accepted standard (see Examples 10 and 11 given in Annex B of good practice [8-1(3)]).

4.2.7 Internal Reflected Component (IRC)

The component of daylight factor contributed by reflection from the inside surfaces varies directly as the window area and inversely as the total area of internal surfaces, and depends on the reflection factor of the floor, wall and roof surfaces inside and of the ground outside. For rooms white-washed on walls and ceiling and windows of normal sizes, the IRC will have sizeable value even at points far away from the window. External obstructions, when present, will proportionately reduce IRC. Where accurate values of IRC are desired, the same may be done in accordance with the good practice [8-1(3)].

4.2.8 General Principles of Openings to Afford Good Lighting

4.2.8.1 Generally, while taller openings give greater penetrations, broader openings give better distribution of light. It is preferable that some area of the sky at an altitude of 20° to 25° should light up the working plane.

4.2.8.2 Broader openings may also be equally or more efficient, provided their sills are raised by 300 mm to 600 mm above the working plane.

NOTE — It is to be noted that while placing window with a high sill level might help natural lighting, this is likely to reduce ventilation at work levels. While designing the opening for ventilation also, a compromise may be made by providing the sill level about 150 mm below the head level of workers.

4.2.8.3 For a given penetration, a number of small openings properly positioned along the same, adjacent or opposite walls will give better distribution of illumination than a single large opening. The sky component at any point, due to a number of openings may be easily determined from the corresponding sky

component contour charts appropriately superposed. The sum of the individual sky component for each opening at the point gives the overall component due to all the openings. The same charts may also facilitate easy drawing of sky component contours due to multiple openings.

4.2.8.4 Unilateral lighting from side openings will, in general, be unsatisfactory if the effective width of the room is more than 2 to 2.5 times the distance from the floor to the top of the opening. In such cases provision of light shelves is always advantageous.

4.2.8.5 Openings on two opposite sides will give greater uniformity of internal daylight illumination, especially when the room is 7 m or more across. They also minimise glare by illuminating the wall surrounding each of the opposing openings. Side openings on one side and clerestory openings on the opposite side may be provided where the situation so requires.

4.2.8.6 Cross-lighting with openings on adjacent walls tends to increase the diffused lighting within a room.

4.2.8.7 Openings in deep reveals tend to minimise glare effects.

4.2.8.8 Openings shall be provided with *Chajjahs*, louvers, baffles or other shading devices to exclude, as far as possible, direct sunlight entering the room. *Chajjahs*, louvers, etc, reduce the effective height of the opening for which due allowance shall be made. Broad and low openings are, in general, much easier to shade against sunlight entry. Direct sunlight, when it enters, increases the inside illuminance very considerably. Glare will result if it falls on walls at low angles, more so than when it falls on floors, especially when the floors are dark coloured or less reflective.

4.2.8.9 Light control media, such as translucent glass panes (opal or matt) surfaced by grinding, etching or sandblasting, configurated or corrugated glass, certain types of prismatic glass, tinted glass and glass blasts are often used. They should be provided, either fixed or movable outside or inside, especially in the upper portions of the openings. The lower portions are usually left clear to afford desirable view. The chief purpose of such fixtures is to reflect part of the light on to the roof and thereby increase the diffuse lighting within, light up the farther areas in the room and thereby produce a more uniform illumination throughout. They will also prevent the opening causing serious glare discomfort to the occupants but will provide some glare when illuminated by direct sunlight.

4.2.9 Availability of Daylight in Multistoreyed Block

Proper planning and layout of building can add appreciably to daylighting illumination inside. Certain

dispositions of building masses offer much less mutual obstruction to daylight than others and have a significant relevance, especially when intensive site planning is undertaken. As guidance, the relative availability of daylight in multi-storeyed blocks (up to 4 storeys) of different relative orientations may be taken as given in Table 7.

Table 7 Relative Availability of Daylight on the Window Plane at Ground Level in a Four-Storeyed Building Blocks (Clear Design-Sky as Basis, Daylight Availability Taken as Unity on an Unobstructed Facade, Values are for the Centre of the Blocks)
(Clause 4.2.9)

Sl No.	Distance of Separation Between Blocks	Infinitely Long Parallel Blocks	Parallel Blocks Facing Each Other (Length = 2 × Height)	Parallel Blocks facing Gaps Between Opposite Blocks (Length = 2 × Height)
(1)	(2)	(3)	(4)	(5)
i)	0.5 Ht	0.15	0.15	0.25
ii)	1.0 Ht	0.30	0.32	0.38
iii)	1.5 Ht	0.40	0.50	0.55
iv)	2.0 Ht	0.50	0.60	0.68

NOTE — Ht = Height of building.

4.2.10 For specified requirements for daylighting of special occupancies and areas, reference may be made to good practice [8-1(4)].

4.3 Artificial Lighting

4.3.1 Artificial lighting may have to be provided,

- a) where the recommended illumination levels have to be obtained by artificial lighting only;
- b) to supplement daylighting when the level of illumination falls below the recommended value; and
- c) where visual task may demand a higher level of illumination.

4.3.2 Artificial Lighting Design for Interiors

For general lighting purposes, the recommended practice is to design for a level of illumination on the working plane on the basis of the recommended levels for visual tasks given in Table 4 by a method called ‘Lumen method’. In order to make the necessary detailed calculations concerning the type and quantity of lighting equipment necessary, advance information on the surface reflectances of walls, ceilings and floors is required. Similarly, calculations concerning the brightness ratio in the interior call for details of the interior decoration and furnishing. Stepwise guidance regarding designing the interior lighting systems for a

building using the ‘Lumen method’ is given in 4.3.2.1 to 4.3.2.4.

4.3.2.1 Determination of the illumination level

Recommended value of illumination shall be taken from Table 4, depending upon the type of work to be carried out in the location in question and the visual tasks involved.

4.3.2.2 Selection of the light sources and luminaires

The selection of light sources and luminaires depends on the choice of lighting system, namely, general lighting, directional lighting and localized or local lighting.

4.3.2.3 Determination of the luminous flux

- a) The luminous flux (F) reaching the working plane depends upon the following:
 - 1) Lumen output of the lamps,
 - 2) Type of luminaire,
 - 3) Proportion of the room (room index) (k_r),
 - 4) Reflectance of internal surfaces of the room,
 - 5) Depreciation in the lumen output of the lamps after burning their rated life, and
 - 6) Depreciation due to dirt collection on luminaires and room surface.
- b) *Coefficient of utilization or utilization factor*
 - 1) The compilation of tables for the utilization factor requires a considerable amount of calculations, especially if these tables have to cover a wide range of lighting practices. For every luminaire, the exact light distribution has to be measured in the laboratory and their efficiencies have to be calculated and measured exactly. These measurements comprise,
 - i) the luminous flux radiated by the luminaires directly to the measuring surface;
 - ii) the luminous flux reflected and re-reflected by the ceiling and the walls to the measuring surface; and
 - iii) the inter-reflections between the ceiling and wall which result in the measuring surface receiving additional luminous flux.

All these measurements have to be made for different reflection factors of the ceiling and the walls for all necessary room indices. These tables have also to indicate the maintenance factor to be taken for the luminous flux depreciation

throughout the life of an installation due to ageing of the lamp and owing to the deposition of dirt on the lamps and luminaires and room surfaces.

- 2) The values of the reflection factor of the ceiling and of the wall are as follows:

White and very light colours :	0.7
Light colours :	0.5
Middle tints :	0.3
Dark colours :	0.1

For the walls, taking into account the influence of the windows without curtains, shelves, almirahs and doors with different colours, etc, should be estimated.

- c) *Calculation for determining the luminous flux [see Table 22 of SP : 41 (S&T) — 1987 ‘Handbook on functional requirements of buildings other than industrial buildings’]*

$$E_{av} = \frac{\mu \cdot \phi}{A}$$

or, $\phi = \frac{E_{av} \cdot A}{\mu}$, for new condition, and

$$\phi = \frac{E_{av} \cdot A}{\mu \cdot d}$$
, for working condition

where

- ϕ = total luminous flux of the light sources installed in the room, in lumens;
- E_{av} = average illumination level required on the working plane, in lux;
- A = area of the working plane, in m²;
- μ = utilization factor in new conditions; and
- d = maintenance factor.

In practice, it is easier to calculate straightaway the number of lamps or luminaires from:

$$N_{lamp} = \frac{E_{av} \cdot A}{\mu \cdot d \cdot \phi_{lamp}}$$

$$N_{luminaires} = \frac{E_{av} \cdot A}{\mu \cdot d \cdot \phi_{luminaires}}$$

where

- ϕ_{lamp} = luminous flux of each lamp, in lumens
- $\phi_{luminaires}$ = luminous flux of each luminaire, in lumens
- N_{lamp} = total number of lamps
- $N_{luminaires}$ = total number of luminaires.

4.3.2.4 Arrangement of the luminaires

This is done to achieve better uniformly distributed illumination. The location of the luminaires has an important effect on the utilization factor.

- a) In general, luminaires are spaced 'x' metre apart in either direction, while the distance of the end luminaire from the wall is '0.5x' metre. The distance 'x' is more or less equal to the mounting height 'H_m' between the luminaire and the working plane. The utilization factor tables are calculated for this arrangement of luminaires [see Table 22 of SP : 41 (S&T) – 1987 'Handbook on functional requirements of buildings other than industrial buildings'].
- b) For small rooms where the room index (k_r) is less than 1, the distance 'x' should always be less than H_m, since otherwise luminaires cannot be properly located. In most cases of such rooms, four or two luminaires are placed for good general lighting. If, however, in such rooms only one luminaire is installed in the middle, higher utilization factors are obtained, but the uniformity of distribution is poor. For such cases, references should be made to the additional tables for k_r = 0.6 to 1.25 for luminaires located centrally.

4.3.3 Artificial Lighting to Supplement Daylighting

4.3.3.1 The need for general supplementary artificial lighting arises due to diminishing of daylighting beyond

design hours, that is, for solar altitude below 15° or when dark cloudy conditions occur.

4.3.3.2 The need may also arise for providing artificial lighting during the day in the innermost parts of the building which cannot be adequately provided with daylighting, or when the outside windows are not of adequate size or when there are unavoidable external obstructions to the incoming daylighting.

4.3.3.3 The need for supplementary lighting during the day arises, particularly when the daylighting on the working plane falls below 100 lux and the surrounding luminance drops below 19 cd/m².

4.3.3.4 The requirement of supplementary artificial lighting increases with the decrease in daylighting availability. Therefore, conditions near sunset or sunrise or equivalent conditions due to clouds or obstructions, etc, represent the worst conditions when the supplementary lighting is most needed.

4.3.3.5 The requirement of supplementary artificial lighting when daylighting availability becomes poor may be determined from Fig. 3 for an assumed ceiling height of 3.0 m, depending upon floor area, fenestration percentage and room surface reflectance. Cool daylight fluorescent tubes are recommended with semi-direct luminaires. To ensure a good distribution of illumination, the mounting height should be between 1.5 m and 2.0 m above the work plane for a separation of 2.0 m to 3.0 m between the luminaires. Also the number of lamps should preferably be more in the rear half of the room than in the vicinity of windows. The

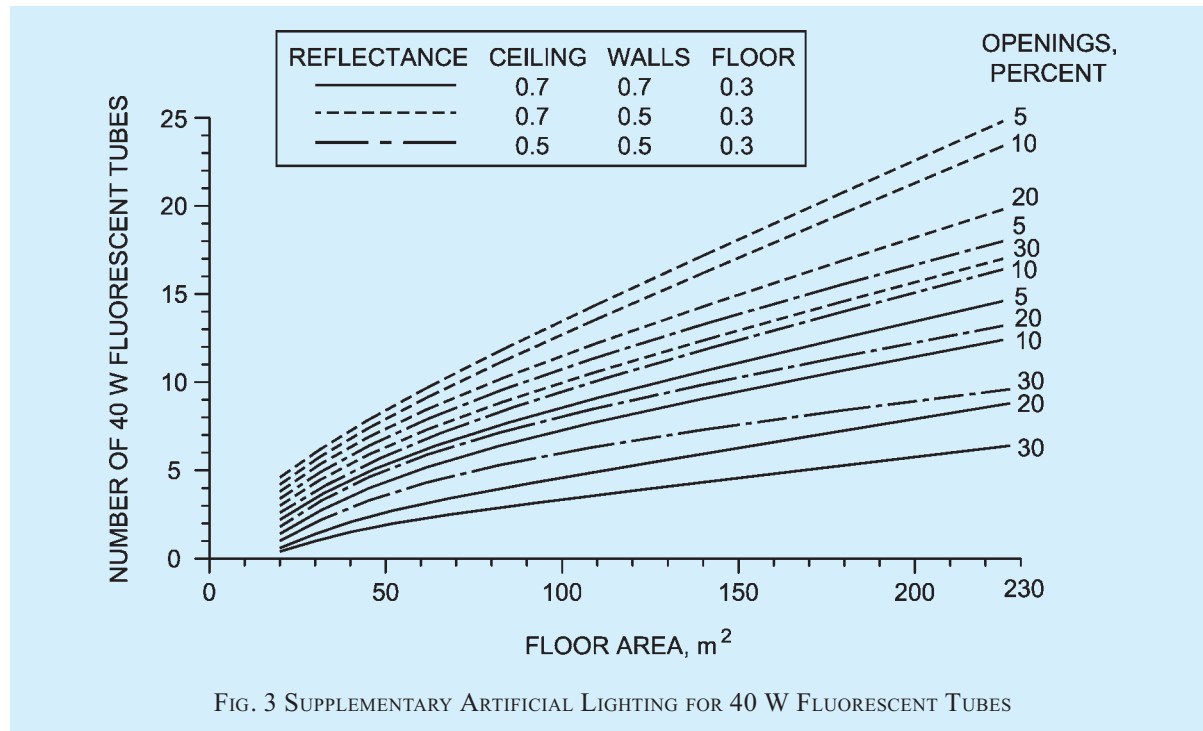

FIG. 3 SUPPLEMENTARY ARTIFICIAL LIGHTING FOR 40 W FLUORESCENT TUBES

following steps may be followed for using Fig. 3 for determining the number of fluorescent tubes required for supplementary daylighting.

- a) Determine fenestration percentage of the floor area, that is,

$$\frac{\text{Window area}}{\text{Floor area}} \times 100$$

- b) In Fig. 3, refer to the curve corresponding to the percent fenestration determined above and the set of reflectances of ceiling, walls and floor actually provided.
- c) For the referred curve of Fig. 3 read, along the ordinate, the number of 40 W fluorescent tubes required, corresponding to the given floor area on the abscissa.

4.3.4 For detailed information on the design aspects and principles of artificial lighting, reference may be made to good practice [8-1(2)].

4.3.5 For specific requirements for lighting of special occupancies and areas, reference may be made to good practice [8-1(5)].

4.3.6 Electrical installation aspect for artificial lighting shall be in accordance with Part 8 'Building Services, Section 2 Electrical and Allied Installations' of the Code.

4.4 Energy Conservation in Lighting

4.4.1 A substantial portion of the energy consumed on lighting may be saved by utilization of daylight and rational design of supplementary artificial lights.

4.4.2 Daytime use of artificial lights may be minimised by proper design of windows for adequate daylight indoors. Daylighting design should be according to 4.2.

4.4.3 Fenestration expressed as percentage of floor area required for satisfactory visual performance of a few tasks for different separation to height (S/H) ratio of external obstructions such as opposite buildings may be obtained from the design nomogram (see Fig. 4). The obstructions at a distance of three times their height or more ($S/H > 3$) from a window façade are not significant and a window facing such an obstruction may be regarded as a case of unobstructed window.

4.4.3.1 The nomogram consists of horizontal lines indicating fenestration percentage of floor area and vertical lines indicating the separation to height ratio of external obstructions such as opposite buildings. Any vertical line for separation to height ratio other than already shown in the nomogram (1.0, 2.0 and 3.0) may be drawn by designer, if required. For cases where there is no obstruction, the ordinate corresponding to the value 3.0 may be used. The value of percentage

fenestration and separation to height ratio are marked on left hand ordinate and abscissa, respectively. The illumination levels are marked on the right hand ordinate. The values given within brackets are the illumination levels on the work plane at center and rear of the room. The wattage of fluorescent tubes required per m^2 of the floor area for different illumination levels is shown on each curve.

4.4.3.2 Following assumptions have been made in the construction of the nomogram:

- a) An average interior finish with ceiling white, walls off white and floor grey has been assumed.
- b) Ceiling height of 3 m, room depths up to 10 m and floor area between 30 m^2 and 50 m^2 have been assumed. For floor area beyond 50 m^2 and less than 30 m^2 , the values of percent fenestration as well as wattage per m^2 should be multiplied by a factor of 0.85 and 1.15, respectively.
- c) It is assumed that windows are of metallic sashes with louvers of width up to 600 mm or a *Chhajja* (balcony projection) at ceiling level of width up to 2.0 m. For wooden sashes, the window area should be increased by a factor of about 1.1.
- d) Luminaires emanating more light in the downward direction than upward direction (such as reflectors with or without diffusing plastics) and mounted at a height of 1.5 m to 2.0 m above the work plane have been considered.

4.4.3.3 Method of use

The following steps shall be followed for the use of nomogram:

- a) *Step 1* — Decide the desired illumination level depending upon the task illumination requirement in the proposed room and read the value of watts per m^2 on the curve corresponding to the required illumination level.
- b) *Step 2* — Fix the vertical line corresponding to the given separation to height ratio of opposite buildings on the abscissa. From the point of intersection of this vertical line and the above curve move along horizontal, and read the value of fenestration percent on the left hand ordinate.
- c) *Step 3* — If the floor area is greater than 50 m^2 or if it is less than 30 m^2 , the value of watt per m^2 as well as fenestration percent may be easily determined for adequate daylighting and supplemental artificial lighting for design

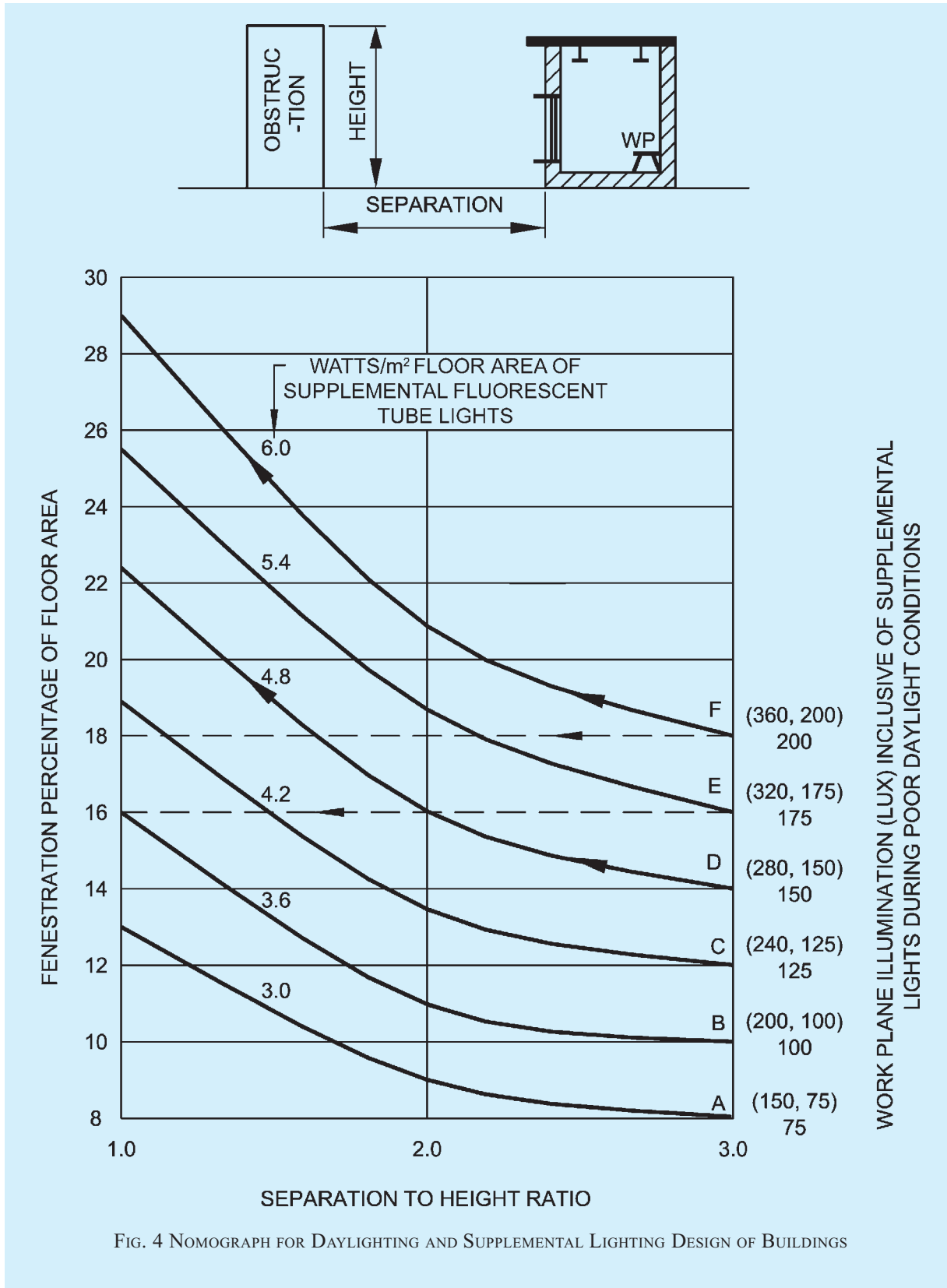

FIG. 4 NOMOGRAPH FOR DAYLIGHTING AND SUPPLEMENTAL LIGHTING DESIGN OF BUILDINGS

purposes. However, if the fenestration provided is less than the required value, the wattage of supplementary artificial lights should be increased proportionately to make up for the deficiency of natural illumination.

4.4.4 For good distribution of day light on the working plane in a room, window height, window width and height of sill should be chosen in accordance with the following recommendations:

- a) In office buildings windows of height 1.2 m or more in the centre of a bay with sill level at 1.0 to 1.2 m above floor and in residential buildings windows of height 1.0 m to 1.1 m with sill height as 0.7 m to 0.9 m above floor are recommended for good distribution of daylight indoors. Window width can accordingly be adjusted depending upon the required fenestration percentage of the floor area.
- b) If the room depth is more than 10 m, windows should be provided on opposite sides for bilateral lighting.
- c) It is desirable to have a white finish for ceiling and off white (light colour) to white for walls. There is about 7 percent improvement in lighting levels in changing the finish of walls from moderate to white.

4.4.5 For good distribution and integration of daylight with artificial lights the following guidelines are recommended:

- a) Employ cool daylight fluorescent tubes for supplementary artificial lighting.
- b) Distribute luminaires with a separation of 2 m to 3 m in each bay of 3 m to 4 m width.
- c) Provide more supplementary lights such as twin tube luminaires in work areas where daylight is expected to be poor, for example in the rear region of a room having single window and in the central region of a room having windows on opposite walls. In the vicinity of windows only single tube luminaires should be provided.

4.4.6 Artificial Lighting

Energy conservation in lighting is affected by reducing wastage and using energy effective lamps and luminaires without sacrificing lighting quality. Measures to be followed comprise utilization of daylight, energy effective artificial lighting design by providing required illumination where needed, turning off artificial lights when not needed, maintaining lighter finishes of ceiling, walls and furnishings, and implementing periodic schedule for cleaning of

luminaires and group replacement of lamps at suitable intervals. Choice of light sources with higher luminous efficacy and luminaires with appropriate light distribution is the most effective means of energy saving in lighting. However, choice of light sources also depends on the other lighting quality parameters like colour rendering index and colour temperature or appearance. For example, high pressure sodium vapour lamps, which have very high luminous efficacy, are not suitable for commercial interiors because of poor colour rendering index and colour appearance, but are highly desirable in heavy industries. Also the choice of light sources depends on the mounting height in the interiors. For example, fluorescent lamps are not preferred for mounting beyond 7 m height, when high pressure gas discharge lamps are preferred because of better optical control due to their compact size.

4.4.6.1 Efficient artificial light sources and luminaires

Luminous efficacies of some of the lamps used in lighting of buildings are given in Table 8 along with average life in burning hours, colour rendering index and colour temperature.

Following recommendations may be followed in the choice of light sources for different locations:

- a) For supplementary artificial lighting of work area in office building care should be taken to use fluorescent lamps, which match with colour temperature of the daylight.
- b) For residential buildings fluorescent lamps and/or CFLs of proper CRI and CCT are recommended to match with the colours and interior design of the room.
- c) For commercial interiors, depending on the mounting heights and interior design, fluorescent lamps, CFLs and low wattage metal halide lamps are recommended. For highlighting the displays in show windows, hotels, etc, low wattage tubular or dichroic reflector type halogen lamps can be used.
- d) For industrial lighting, depending on the mounting height and colour consideration fluorescent lamps, high pressure mercury vapour lamps or high pressure sodium vapour lamps are recommended.

4.4.6.2 For the same lumen output, it is possible to save 50 to 70 percent energy if CFL lamps are replaced with induction lighting, and 40 to 60 percent if replaced with LED lamps. Similar energy effective solutions are to be chosen for every application area.

Similarly with white fluorescent tubes recommended for corridors and staircases, the electrical consumption reduces to 1/4.5 of the energy consumption with incandescent lamps.

Table 8 Luminous Efficacy, Life, Lumen Maintenance and Colour Rendition of Light Sources

(Clause 4.4.6.1)

Sl No.	Light Source	Wattage Range W	Efficacy lm/W	Average Life h	Lumen Maintenance	Colour Rendition
(1)	(2)	(3)	(4)	(5)	(6)	(7)
i)	Incandescent lamps	15 to 200	12 to 20	500 to 1 000	Fair to good	Very good
ii)	Tungsten halogen	300 to 1 500	20 to 27	200 to 2 000	Good to very good	Very good
iii)	Standard fluorescent lamps	20 to 80	55 to 65	5 000	Fair to good	Good
iv)	Compact fluorescent lamps (CFL)	5 to 40	60 to 70	7 500	Good	Good to very good
v)	Slim line fluorescent	18 to 58	57 to 67	5 000	Fair to good	Good
v)	High pressure mercury vapour lamps	60 to 1 000	50 to 65	5 000	Very low to fair	Federate
vi)	Blended - light lamps	160 to 250	20 to 30	5 000	Low to fair	Federate
vii)	High pressure sodium vapour lamps	50 to 1 000	90 to 125	10 000 to 15 000	Fair to good	Low to good
viii)	Metal halide lamps	35 to 2 000	80 to 95	4 000 to 10 000	Very low	Very good
ix)	Low pressure sodium	10 to 180	100 to 200	10 000 to 20 000	Good to very good	Poor
x)	LED	0.5 to 2.0	60 to 100	10 000	Very good	Good for white LED

NOTES

- 1 The table includes lamps and wattages currently in use in buildings in India.
- 2 Luminous efficacy varies with the wattage of the lamp.
- 3 Average life values are from available Indian Standards. Where Indian Standard is not available, values given are only indicative.
- 4 For exact values, it is advisable to contact manufacturers.

4.4.6.3 Efficient luminaire also plays an important role for energy conservation in lighting. The choice of a luminaire should be such that it is efficient not only initially but also throughout its life. Following luminaries are recommended for different locations:

- a) For offices semi-direct type of luminaries are recommended so that both the work plane illumination and surround luminance can be effectively enhanced.
- b) For corridors and stair cases direct type of luminaries with wide spread of light distributions are recommended.
- c) In residential buildings, bare fluorescent tubes are recommended. Wherever the incandescent lamps are employed, they should be provided with white enameled conical reflectors at an inclination of about 45° from vertical.

4.4.7 Cleaning Schedule for Window Panes and Luminaires

Adequate schedule for cleaning of window panes and luminaries will result in significant advantage of enhanced daylight and lumen output from luminaries. This will tend to reduce the duration over which artificial lights will be used and minimise the wastage of energy. Depending upon the location of the building a minimum of three to six months interval for periodic cleaning of luminaries and window panes is

recommended for maximum utilization of daylight and artificial lights.

4.4.8 Photocontrols for Artificial Lights

There is a considerable wastage of electrical energy in lighting of buildings due to carelessness in switching off lights even when sufficient daylight is available indoors. In offices and commercial buildings, occupants may switch on lights in the morning and keep them on throughout the day. When sufficient daylight is available inside, suitable photo controls can be employed to switch off the artificial lights and thus prevent the wastage of energy.

The photocontrol should have the following features:

- a) An integrated photocontrol system continually measures the amount of visible light under the lighting fixture and maintains the lux levels as referred in Table 4.
- b) An integrated photocontrol system should maintain six daylighting scenarios that can be adjusted by the user namely; daytime occupied, daytime unoccupied, sunset occupied, sunset unoccupied, night time occupied and night time unoccupied.
- c) The photocontrol sensor should have a 60° cone of reference to measure the amount of light on the work surface.

4.4.9 Solar Photovoltaic Systems (SPV)

Solar photovoltaic system enables direct conversion of sunlight into electricity and is a viable option for lighting purpose in remote nongrid areas. The common SPV lighting systems are:

- a) Solar lantern,
- b) Fixed type solar home lighting system, and
- c) Street lighting system.

4.4.9.1 SPV lighting system should preferably be provided with CFL for energy efficiency.

4.4.9.2 Inverters used in buildings for supplying electricity during the power cut period should be charged through SPV system.

4.4.9.3 Regular maintenance of SPV system is necessary for its satisfactory functioning.

4.4.10 Lighting shelves and light pipes may be explored for utilization and integration in the lighting design.

5 VENTILATION

5.1 General

Ventilation of buildings is required to supply fresh air for respiration of occupants, to dilute inside air to prevent vitiation by body odours and to remove any products of combustion or other contaminants in air and to provide such thermal environments as will assist in the maintenance of heat balance of the body in order to prevent discomfort and injury to health of the occupants.

5.2 Design Considerations

5.2.1 Respiration

Supply of fresh air to provide oxygen for the human body for elimination of waste products and to maintain carbon dioxide concentration in the air within safe limits rarely calls for special attention as enough outside air for this purpose normally enters the areas of occupancy through crevices and other openings.

5.2.1.1 In normal habitable rooms devoid of smoke generating source, the content of carbon dioxide in air rarely exceeds 0.5 percent to 1 percent and is, therefore, incapable of producing any ill effect. The amount of air required to keep the concentration down to 1 percent is very small. The change in oxygen content is also too small under normal conditions to have any ill effects; the oxygen content may vary quite appreciably without noticeable effect, if the carbon dioxide concentration is unchanged.

5.2.2 Vitiation by Body Odours

Where no products of combustion or other

contaminants are to be removed from air, the amount of fresh air required for dilution of inside air to prevent vitiation of air by body odours, depends on the air space available per person and the degree of physical activity; the amount of air decreases as the air space available per person increases, and it may vary from 20 m³ to 30 m³ per person per hour. In rooms occupied by only a small number of persons such an air change will automatically be attained in cool weather by normal leakage around windows and other openings and this may easily be secured in warm weather by keeping the openings open.

No standards have been laid down under *Factories Act, 1948* as regards the amount of fresh air required per worker or the number of air changes per hour. Section 16 of the *Factories Act, 1948* relating to overcrowding requires that at least 14 m³ to 16 m³ of space shall be provided for every worker and for the purpose of that section no account shall be taken of any space in a work room which is more than 4.25 m above the floor level.

NOTE — Vitiation of the atmosphere can also occur in factories by odours given off due to contaminants of the product itself, say for example, from tobacco processing in a ‘*Beedi*’ factory. Here the ventilation will have to be augmented to keep odours within unobjectionable levels.

5.2.2.1 Recommended values for air changes

The standards of general ventilation are recommended/ based on maintenance of required oxygen, carbon dioxide and other air quality levels and for the control of body odours when no products of combustion or other contaminants are present in the air; the values of air changes should be as follows:

<i>Sl No.</i>	<i>Application</i>	<i>Air Change per Hour</i>
(1)	(2)	(3)
1.	Assembly rooms	4-8
2.	Bakeries	20-30
3.	Banks/building societies	4-8
4.	Bathrooms	6-10
5.	Bedrooms	2-4
6.	Billiard rooms	6-8
7.	Boiler rooms	see Note 2
8.	Cafes and coffee bars	10-12
9.	Canteens	8-12
10.	Cellars	3-10
11.	Changing rooms	6-10
12.	Churches	1-3
13.	Cinemas and theatres	10-15
14.	Club rooms	12, <i>Min</i>
15.	Compressor rooms	10-12
16.	Conference rooms	8-12
17.	Corridors	5-10

Sl No. (1)	Application (2)	Air Change per Hour (3)
18.	Dairies	8-12
19.	Dance halls	12, <i>Min</i>
20.	Dye works	20-30
21.	Electroplating shops	10-12
22.	Engine rooms/DG Rooms/GG Rooms	<i>see Note 2</i>
23.	Entrance halls	3-5
24.	Factories and work shops	8-10
25.	Foundries	15-30
26.	Garages	6-8
27.	Glass houses	25-60
28.	Gymnasium	6, <i>Min</i>
29.	Hair dressing saloon	10-15
30.	Hospitals sterilising	15-25
31.	Hospital wards	6-8
32.	Hospital domestic	15-20
33.	Laboratories	6-15
34.	Launderettes	10-15
35.	Laundries	10-30
36.	Lavatories	6-15
37.	Lecture theatres	5-8
38.	Libraries	3-5
39.	Lift cars	20, <i>Min</i>
40.	Living rooms	3-6
41.	Mushroom houses	6-10
42.	Offices	6-10
43.	Paint shops (not cellulose)	10-20
44.	Photo and X-ray dark room	10-15
45.	Public house bars	12, <i>Min</i>
46.	Recording control rooms	15-25
47.	Recording studios	10-12
48.	Restaurants	8-12
49.	Schoolrooms	5-7
50.	Shops and supermarkets	8-15
51.	Shower baths	15-20
52.	Stores and warehouses	3-6
53.	STP rooms	30, <i>Min</i>
54.	Squash courts	4, <i>Min</i>
55.	Swimming baths	10-15
56.	Toilets	6-10
57.	Underground vehicle parking	6, <i>Min</i>
58.	Utility rooms	15-30
59.	Welding shops	15-30

NOTES

- 1 The ventilation rates may be increased by 50 percent where heavy smoking occurs or if the room is below the ground.
- 2 The ventilation rate shall be as per 11.2.2 of Part 8 'Building Services, Section 3 Air Conditioning, Heating and Mechanical Ventilation' of the Code.

5.2.3 Heat Balance of Body

Especially in hot weather, when thermal environment inside the room is worsened by heat given off by machinery, occupants and other sources, the prime need for ventilation is to provide such thermal environment as will assist in the maintenance of heat balance of the body in order to prevent discomfort and injury to health. Excess of heat either from increased metabolism due to physical activity of persons or gains from a hot environment has to be offset to maintain normal body temperature (37°C). Heat exchange of the human body with respect to the surroundings is determined by the temperature and humidity gradient between the skin and the surroundings and other factors, such as age of persons, clothing, etc, and the latter depends on air temperature (dry bulb temperature), relative humidity, radiation from the solid surroundings and rate of air movement. The volume of outside air to be circulated through the room is, therefore, governed by the physical considerations of controlling the temperature, air distribution or air movement. Air movement and air distribution may, however, be achieved by recirculation of the inside air rather than bringing in all outside air. However, fresh air supply or the circulated air will reduce heat stress by dissipating heat from body by evaporation of the sweat, particularly when the relative humidity is high and the air temperature is near body temperature.

5.2.3.1 Indices of thermal comfort

Thermal comfort is that condition of thermal environment under which a person can maintain a body heat balance at normal body temperature and without perceptible sweating. Limits of comfort vary considerably according to studies carried out in India and abroad.

The thermal indices which find applications for Indian climate are as follows:

- a) Effective temperature (ET),
- b) Tropical summer index (TSI), and
- c) Adaptive thermal comfort.

5.2.3.1.1 Effective temperature (ET)

Effective temperature is defined as the temperature of still, saturated air which has the same general effect upon comfort as the atmosphere under investigation. Combinations of temperature, humidity and wind velocity producing the same thermal sensation in an individual are taken to have the same effective temperature.

Initially two scales were developed, one of which referred to men stripped to the waist, and called the basic scale. The other applies to men fully clad in indoor clothing and called the normal scale of effective

temperature. Bedford (1946) proposed the use of globe temperature reading instead of the air temperature reading to make allowance for the radiant heat. This scale is known as the corrected effective temperature (CET) scale. No allowance, however, was made for the different rates of energy expenditure. The scale was compiled only for men either seated or engaged in light activity.

Figure 5 represents the corrected effective temperature nomogram. The CET can be obtained by connecting the appropriate points representing the dry bulb (or globe) and wet bulb temperatures and reading the CET value at the intersection of this line with the relevant air velocity curve from the family of curves for various air velocities running diagonally upwards from left to right.

The effective temperature scale may be considered to be reasonably accurate in warm climates where the heat stress is not high but it may be misleading at high levels of heat stress. There appears to be an inherent error in this scale if used as an index of physiological strain, the error increasing with the severity of the environmental conditions. For low and moderate degrees of heat stress, the effective temperature scales

appear to assess climatic heat stress with an accuracy which is acceptable for most practical purposes.

5.2.3.1.2 Tropical summer index (TSI)

The TSI is defined as the temperature of calm air, at 50 percent relative humidity which imparts the same thermal sensation as the given environment. The 50 percent level of relative humidity is chosen for this index as it is a reasonable intermediate value for the prevailing humidity conditions. Mathematically, TSI (°C) is expressed as:

$$TSI = 0.745t_g + 0.308t_w - 2.06\sqrt{v + 0.841}$$

where

- t_w = wet bulb temperature, in °C;
- t_g = globe temperature, in °C; and
- V = air speed, in m/s.

The thermal comfort of a person lies between TSI values of 25°C and 30°C with optimum condition at 27.5°C. Air movement is necessary in hot and humid weather for body cooling. A certain minimum desirable wind speed is needed for achieving thermal comfort at different temperatures and relative humidities. Such

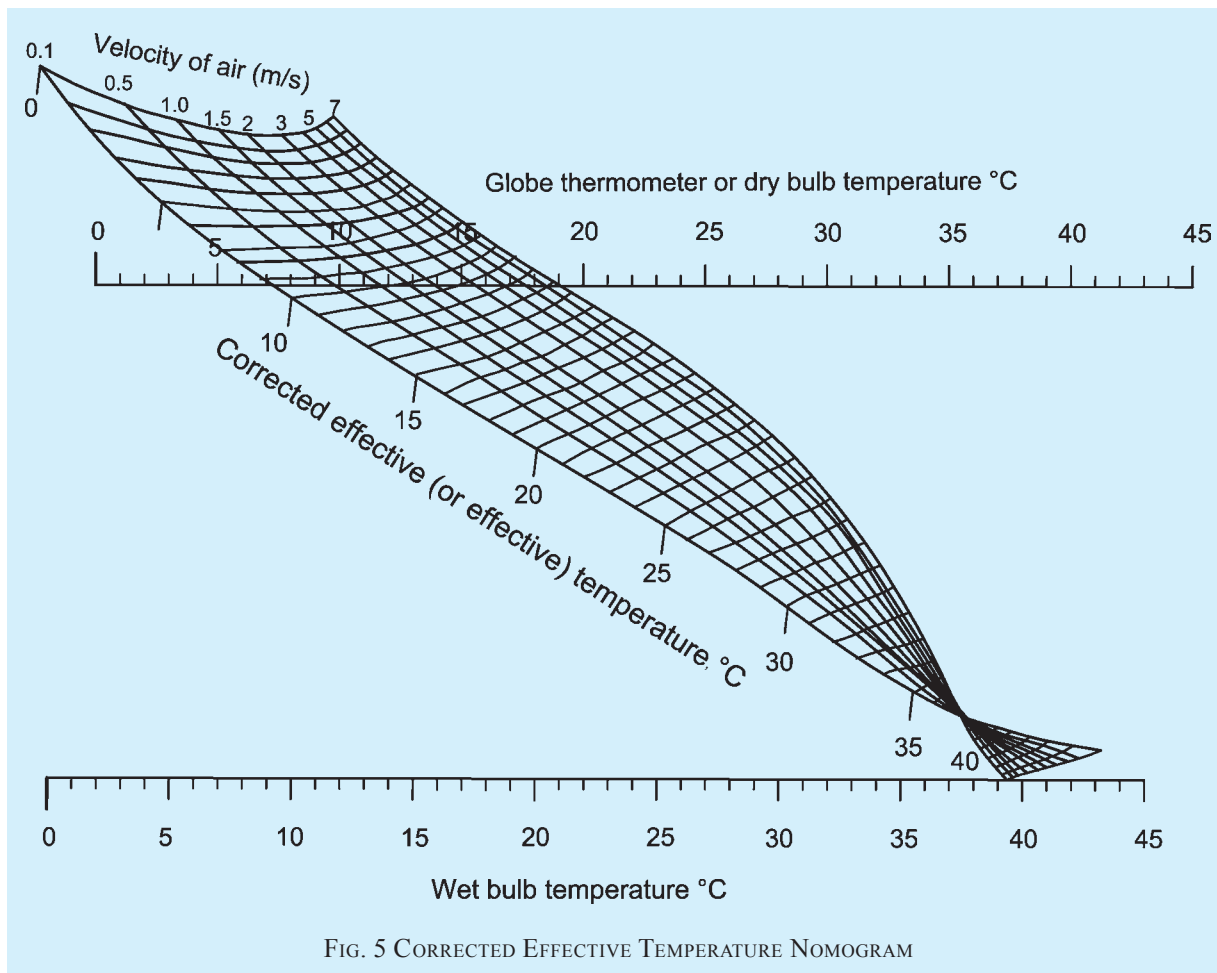

FIG. 5 CORRECTED EFFECTIVE TEMPERATURE NOMOGRAM

wind speeds are given in Table 9. These are applicable to sedentary work in offices and other places having no noticeable sources of heat gain. Where somewhat warmer conditions are prevalent, such as in godowns and machine shops and work is of lighter intensity, and higher temperatures can be tolerated without much discomfort, minimum wind speeds for just acceptable warm conditions are given in Table 10. For obtaining values of indoor wind speed above 2.0 m/s, mechanical means of ventilation may have to be adopted (*see also* Part 8 ‘Building Services, Section 3 Air Conditioning, Heating and Mechanical Ventilation’ of the Code).

The warmth of the environment was found tolerable between 30°C and 34°C (TSI), and too hot above this limit. On the lower side, the coolness of the environment was found tolerable between 19°C and 25°C (TSI) and below 19°C (TSI), it was found too cold.

Table 9 Desirable Wind Speeds (m/s) for Thermal Comfort Conditions
(Clause 5.2.3.1.2)

Sl. No.	Dry Bulb Temperature °C	Relative Humidity Percent						
		30	40	50	60	70	80	90
(1)	(2)	(3)	(4)	(5)	(6)	(7)	(8)	(9)
i)	28	1)	1)	1)	1)	1)	1)	1)
ii)	29	1)	1)	1)	1)	1)	0.06	0.19
iii)	30	1)	1)	1)	0.06	0.24	0.53	0.85
iv)	31	1)	0.06	0.24	0.53	1.04	1.47	2.10
v)	32	0.20	0.46	0.94	1.59	2.26	3.04	2)
vi)	33	0.77	1.36	2.12	3.00	2)	2)	2)
vii)	34	1.85	2.72	2)	2)	2)	2)	2)
viii)	35	3.20	2)	2)	2)	2)	2)	2)

1) None.
2) Higher than those acceptable in practice.

Table 10 Minimum Wind Speeds (m/s) for Just Acceptable Warm Conditions
(Clause 5.2.3.1.2)

Sl. No.	Dry Bulb Temperature °C	Relative Humidity Percent						
		30	40	50	60	70	80	90
(1)	(2)	(3)	(4)	(5)	(6)	(7)	(8)	(9)
i)	28	1)	1)	1)	1)	1)	1)	1)
ii)	29	1)	1)	1)	1)	1)	1)	1)
iii)	30	1)	1)	1)	1)	1)	1)	1)
iv)	31	1)	1)	1)	1)	1)	0.06	0.23
v)	32	1)	1)	1)	0.09	0.29	0.60	0.94
vi)	33	1)	0.04	0.24	0.60	1.04	1.85	2.10
vii)	34	0.15	0.46	0.94	1.60	2.26	3.05	2)
viii)	35	0.68	1.36	2.10	3.05	2)	2)	2)
ix)	36	1.72	2.70	2)	2)	2)	2)	2)

1) None.
2) Higher than those acceptable in practice.

5.2.3.1.3 Adaptive thermal comfort

For details on adaptive thermal comfort, reference shall be made to Part 8 ‘Building Services, Section 3 Air Conditioning, Heating and Mechanical Ventilation’ of this Code.

5.2.3.2 There will be a limit of heat tolerance when air temperatures are excessive and the degree of physical activity is high. This limit is determined when the bodily heat balance is upset, that is, when the bodily heat gain due to conduction, convection and the radiation from the surroundings exceeds the bodily heat loss, which is mostly by evaporation of sweat from the surface of the body. The limits of heat tolerance for Indian workers are based on the study conducted by the Chief Adviser Factories, Government of India, Ministry of Labour and are given in his report on Thermal Stress in Textile Industry (Report No. 17) issued in 1956. According to this Report, where workers in industrial buildings wearing light clothing are expected to do work of moderate severity with the energy expenditure in the range 273 to 284 W, the maximum wet bulb temperature shall not exceed 29°C and adequate air movement subject to a minimum air velocity of 30 m/min shall be provided, and in relation to the dry bulb temperature, the wet bulb temperature of air in the work room, as far as practicable, shall not exceed that given in Table 11.

Table 11 Maximum Permissible Wet Bulb Temperatures for Given Dry Bulb Temperatures
(Clause 5.2.3.2)

Sl. No.	Dry Bulb Temperature °C	Maximum Wet-Bulb Temperature °C
(1)	(2)	(3)
i)	30	29.0
ii)	35	28.5
iii)	40	28.0
iv)	45	27.5
v)	50	27.0

NOTES

1 These are limits beyond which the industry should not allow the thermal conditions to go for more than 1h continuously. The limits are based on a series of studies conducted on Indian subjects in psychrometric chamber and on other data on heat casualties in earlier studies conducted in Kolar Gold Fields and elsewhere.

2 Figures given in this table are not intended to convey that human efficiency at 50°C will remain the same as at 30°C, provided appropriate wet bulb temperatures are maintained. Efficiency decreases with rise in the dry bulb temperature as well, as much as possible. Long exposures to temperature of 50°C dry bulb/27°C wet bulb may prove dangerous.

3 Refrigeration or some other method of cooling is recommended in all cases where conditions would be worse than those shown in this table.

5.3 Methods of Ventilation

General ventilation involves providing a building with relatively large quantities of outside air in order to improve general environment of the building. This may be achieved in one of the following ways:

- a) Natural supply and natural exhaust of air;
- b) Natural supply and mechanical exhaust of air;
- c) Mechanical supply and natural exhaust of air; and
- d) Mechanical supply and mechanical exhaust of air.

5.3.1 Control of Heat

Although it is recognized that general ventilation is one of the most effective methods of improving thermal environmental conditions in factories, in many situations, the application of ventilation should be preceded by and considered along with some of the following other methods of control. This would facilitate better design of buildings for general ventilation, either natural or mechanical or both, and also reduce their cost.

5.3.1.1 Isolation

Sometimes it is possible to locate heat producing equipment, such as furnaces in such a position as would expose only a small number of workers to hot environment. As far as practicable, such sources of heat in factories should be isolated.

In situations where relatively few people are exposed to severe heat stress and their activities are confined to limited areas as in the case of rolling mill operators and crane operators, it may be possible to enclose the work areas and provide spot cooling or supply conditioned air to such enclosures.

5.3.1.2 Insulation

A considerable portion of heat in many factories is due to the solar radiation falling on the roof surfaces, which, in turn, radiate heat inside the building. In such situations, insulations of the roof or providing a false ceiling or double roofing would be very effective in controlling heat. Some reduction can also be achieved by painting the roof in heat reflective shades.

Hot surfaces of equipment, such as pipes, vessels, etc, in the building should also be insulated to reduce their surface temperature.

5.3.1.3 Substitution

Sometimes, it is possible to substitute a hot process by a method that involves application of localized or more efficiently controlled method of heating. Examples include induction hardening instead of conventional

heat treatment, cold riveting or spot welding instead of hot riveting, etc.

5.3.1.4 Radiant shielding

Hot surfaces, such as layers of molten metal emanate radiant heat, which can best be controlled by placing a shield having a highly reflecting surface between the source of heat and the worker, so that a major portion of the heat falling on the shield is reflected back to the source. Surfaces such as of tin and aluminium have been used as materials for shields. The efficiency of the shield does not depend on its thickness, but on the reflectivity and emissivity of its surface. Care should be taken to see that the shield is not heated up by conduction and for this purpose adequate provision should be made for the free flow upwards of the heated air between the hot surface and the shield by leaving the necessary air space and providing opening at the top and the bottom of the sides.

5.3.2 Volume of Air Required

The volume of air required shall be calculated by using both the sensible heat and latent heat gain as the bases. The larger of the two values obtained should be used in actual practice.

In places without sufficient wind speeds and/or in buildings where effective cross ventilation is not possible due to the design of the interior, the indoor air may be exhausted by a fan, with outdoor air entering the building through the open windows.

5.3.2.1 Volume of air required for removing sensible heat

When the amount of sensible heat given off by different sources, namely, the sun, the manufacturing processes, machinery, occupants and other sources, is known and a suitable value for the allowable temperature rise is assumed, the volume of outside air to be provided for removing the sensible heat may be calculated from:

$$Q_1 = \frac{2.976 \ 8 \ K_s}{t}$$

where

Q_1 = quantity of air, in m³/h;

K_s = sensible heat gained, in W; and

t = allowable temperature rise, in °C.

5.3.2.2 Temperature rise refers mainly to the difference between the air temperatures at the outlet (roof exit) and at the inlet openings for outside air. As very little inlet data exist on allowable temperature rise values for supply of outside air in summer months, the values given in Table 12 related to industrial buildings may be used for general guidance.

Table 12 Allowable Temperature Rise Values
(Clause 5.3.2.2)

Sl No.	Height of Outlet Opening m	Temperature Rise °C
(1)	(2)	(3)
i)	6	3 to 4.5
ii)	9	4.5 to 6.5
iii)	12	6.5 to 11

NOTES

1 The conditions are limited to light or medium heavy manufacturing processes, freedom from radiant heat and inlet openings not more than 3 to 4.5 m above floor level.

2 At the working zone between floor level and 1.5 m above floor level, the recommended maximum allowable temperature rise for air is 2°C to 3°C above the air temperature at the inlet openings.

5.3.2.3 Volume of air required for removing latent heat

If the latent heat gained from the manufacturing processes and occupants is also known and a suitable value for the allowable rise in the vapour pressure is assumed:

$$Q_2 = \frac{4\ 127.26\ K_1}{h}$$

where

- Q_2 = quantity of air, in m³/h;
- K_1 = latent heat gained, in W; and
- h = allowable vapour pressure difference of mercury, in mm.

NOTE — In majority of the cases, the sensible heat gain will far exceed the latent heat gain, so that the amount of outside air to be drawn by ventilating equipment can be calculated in most cases on the basis of the equation given in 5.3.2.1.

5.3.2.4 Ventilation is also expressed as m³/h/m² of floor area. This relationship fails to evaluate the actual heat relief provided by a ventilation system, but it does give a relationship which is independent of building height. This is a more rational approach, because, with the same internal load, the same amount of ventilation air, properly applied to the work zone with adequate velocity, will provide the desired heat relief quite independently of the ceiling height of the space, with few exceptions. Ventilation rates of 30 to 60 m³/h/m² have been found to give good results in many plants.

5.4 Natural Ventilation

The rate of ventilation by natural means through windows or other openings depends on,

- a) direction and velocity of wind outside and sizes and disposition of openings (wind action); and
- b) convection effects arising from temperature of vapour pressure difference (or both)

between inside and outside the room and the difference of height between the outlet and inlet openings (stack effect).

5.4.1 Ventilation of Non-Industrial Buildings

Ventilation in non-industrial buildings due to stack effect, unless there is a significant internal load, could be neglected, except in cold regions, and wind action may be assumed to be predominant.

5.4.1.1 In hot dry regions, the main problem in summer is to provide protection from sun’s heat so as to keep the indoor temperature lower than those outside under the sun. For this purpose windows and other openings are generally kept closed during day time and only minimum ventilation is provided for the control of odours or for removal of products of combustion.

5.4.1.2 In warm humid regions, the problem in the design of non-industrial buildings is to provide free passage of air to keep the indoor temperature as near to those outside in the shade as possible, and for this purpose the buildings are oriented to face the direction of prevailing winds and windows and other openings are kept open on both windward and leeward sides.

5.4.1.3 In winter months in cold regions, the windows and other openings are generally kept shut, particularly during night; and ventilation necessary for the control of odours and for the removal of products of combustion can be achieved either by stack action or by some infiltration of outside air due to wind action.

5.4.2 Ventilation of Industrial Buildings

In providing natural ventilation of all industrial buildings having significant internal heat loads due to manufacturing process, proper consideration should be given to the size and distribution of windows and other inlet openings in relation to outlet openings so as to give, with due regard to orientation, prevailing winds, size and configuration of the building and manufacturing processes carried on, maximum possible control of thermal environment.

5.4.2.1 In the case of industrial buildings wider than 30 m, the ventilation through windows may be augmented by roof ventilation.

5.4.3 Design Guidelines for Natural Ventilation

5.4.3.1 By wind action

- 1) A building need not necessarily be oriented perpendicular to the prevailing outdoor wind; it may be oriented at any convenient angle between 0° and 30° without losing any beneficial aspect of the breeze. If the prevailing wind is from East or West, building may be oriented at 45° to the incident wind so

as to diminish the solar heat without much reduction in air motion indoors.

- 2) Inlet openings in the buildings should be well distributed and should be located on the windward side at a low level, and outlet openings should be located on the leeward side. Inlet and outlet openings at high levels may only clear the top air at that level without producing air movement at the level of occupancy.
- 3) Maximum air movement at a particular plane is achieved by keeping the sill height of the opening at 85 percent of the critical height (such as head level) for the following recommended levels of occupancy:
 - a) For sitting on chair 0.75 m,
 - b) For sitting on bed 0.60 m, and
 - c) For sitting on floor 0.40 m.
- 4) Inlet openings should not as far as possible be obstructed by adjoining buildings, trees, sign boards or other obstructions or by partitions inside in the path of air flow.
- 5) In rooms of normal size having identical windows on opposite walls the average indoor air speed increases rapidly by increasing the width of window up to two-third of the wall width; beyond that the increase is in much smaller proportion than the increase of the window width. The air motion in the working zone is maximum when window height is 1.1m. Further increase in window height promotes air motion at higher level of window, but does not contribute additional benefits as regards air motion in the occupancy zones in buildings.
- 6) Greatest flow per unit area of openings is obtained by using inlet and outlet openings of nearby equal areas at the same level.

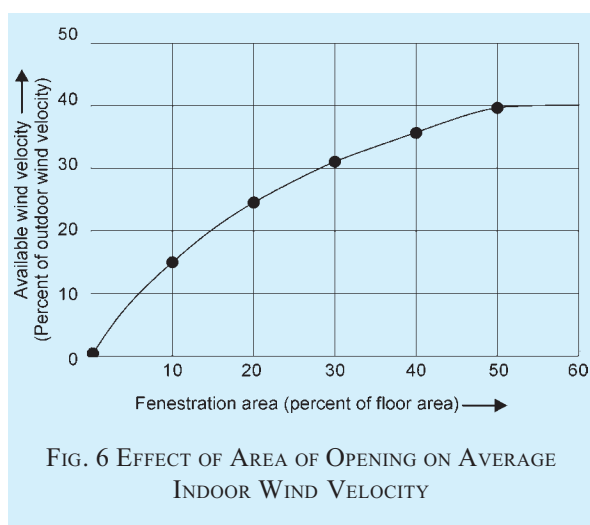

- 7) For a total area of openings (inlet and outlet) of 20 percent to 30 percent of floor area, the average indoor wind velocity is around 30 percent of outdoor velocity. Further increase in window size increases the available velocity but not in the same proportion as shown in Fig. 6. In fact, even under most favourable conditions the maximum average indoor wind speed does not exceed 40 percent of outdoor velocity.
- 8) Where the direction of wind is quite constant and dependable, the size of the inlet should be kept within 30 to 50 percent of the total area of openings and the building should be oriented perpendicular to the incident wind. Where direction of the wind is quite variable the openings may be arranged so that as far as possible there is approximately equal area on all sides. Thus no matter what the wind direction be, there would be some openings directly exposed to wind pressure and others to air suction and effective air movement through the building would be assured.
- 9) Windows of living rooms should open directly to an open space. In places where building sites are restricted, open space may have to be created in the buildings by providing adequate courtyards.
- 10) In the case of rooms with only one wall exposed to outside, provision of two windows on that wall is preferred to that of a single window.
- 11) Windows located diagonally opposite to each other with the windward window near the upstream corner give better performance than other window arrangements for most of the building orientations.
- 12) Horizontal louvers, that is, sunshades atop windows deflect the incident wind upward and reduce air motion in the zone of occupancy. A horizontal slot between the wall and horizontal louver prevents upward deflection of air in the interior of rooms. Provision of inverted L type (Γ) louver increases the room air motion provided that the vertical projection does not obstruct the incident wind (see Fig. 7).
- 13) Provision of horizontal sashes inclined at an angle of 45° in appropriate direction helps to promote the indoor air motion. Sashes projecting outward are more effective than projecting inward.
- 14) Air motion at working plane 0.4 m above the floor can be enhanced by 30 percent using a pelmet type wind deflector (see Fig. 8).

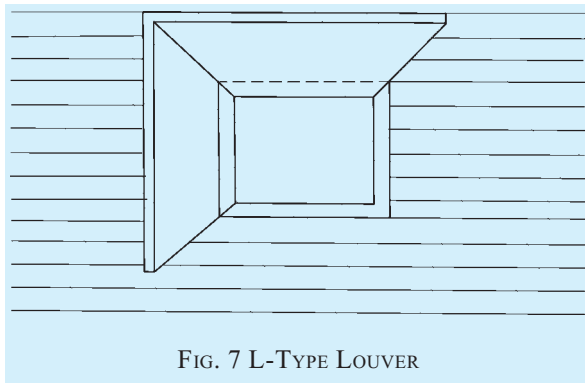

FIG. 7 L-TYPE LOUVER

- 15) Roof overhangs help promoting air motion in the working zone inside buildings.
- 16) In case of room with windows on one wall, with single window, the room wind velocity inside the room on the windward side is 10 percent of outdoor velocity at points up to a distance of one-sixth of room width from the window and then decreases rapidly and hardly any air movement is produced in the leeward half portion of the room. The average indoor wind velocity is generally less than 10 percent of outdoor velocity. When two windows are provided and wind impinges obliquely on them, the inside velocity increases up to 15 percent of the outdoor velocity.

- 17) Cross ventilation can be obtained through one side of the building to the other, in case of narrow buildings with the width common in the multistoreyed type by the provision of large and suitably placed windows or combination of windows and wall ventilators for the inflow and outflow of air.
- 18) *Verandah* open on three sides is to be preferred since it causes an increase in the room air motion for most of the orientations of the building with respect to the outdoor wind.
- 19) A partition placed parallel to the incident wind has little influence on the pattern of the air flow, but when located perpendicular to the main flow, the same partition creates a wind shadow. Provision of a partition with spacing of 0.3 m underneath helps augmenting air motion near floor level in the leeward compartment of wide span buildings.
- 20) Air motion in a building unit having windows tangential to the incident wind is accelerated when another unit is located at end-on position on downstream side (see Fig. 9).
- 21) Air motion in two wings oriented parallel to the prevailing breeze is promoted by connecting them with a block on downstream side.

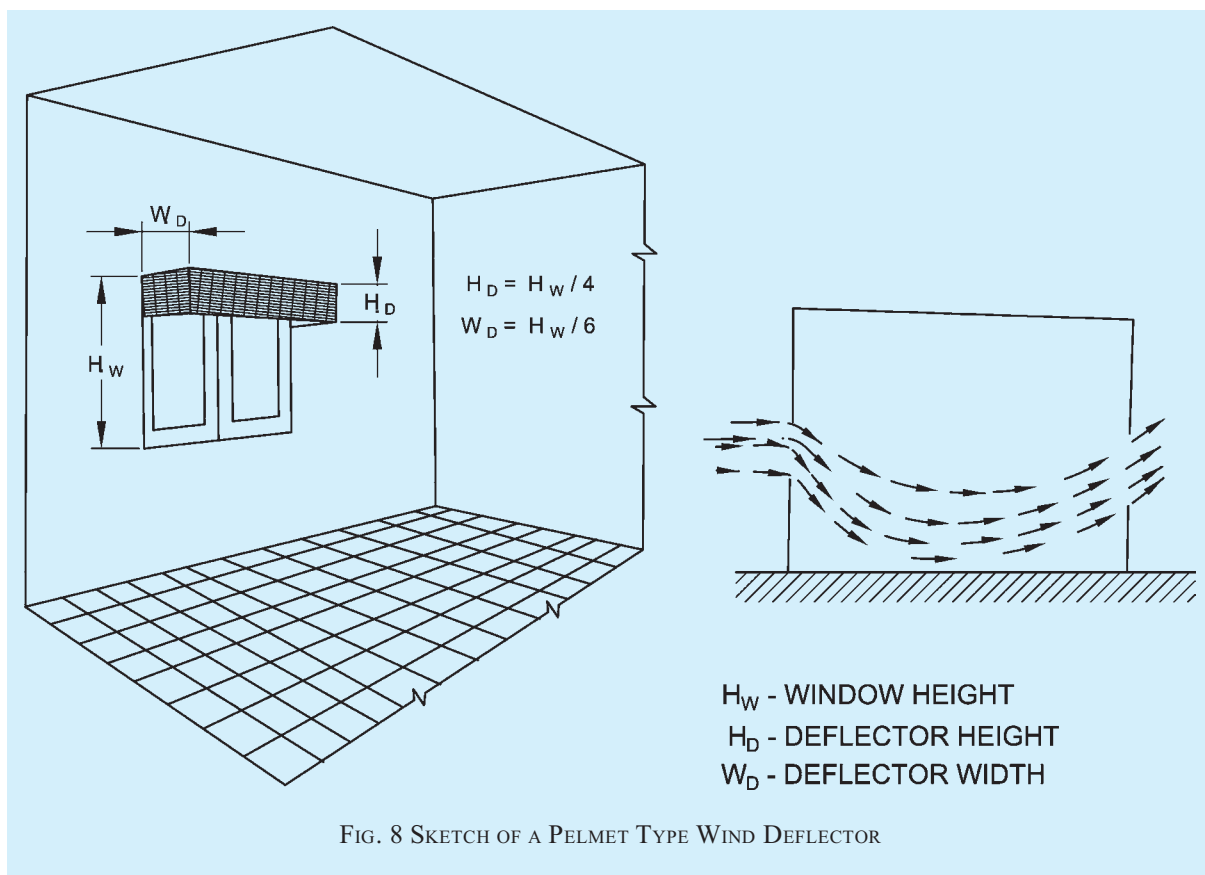

FIG. 8 SKETCH OF A PELMET TYPE WIND DEFLECTOR

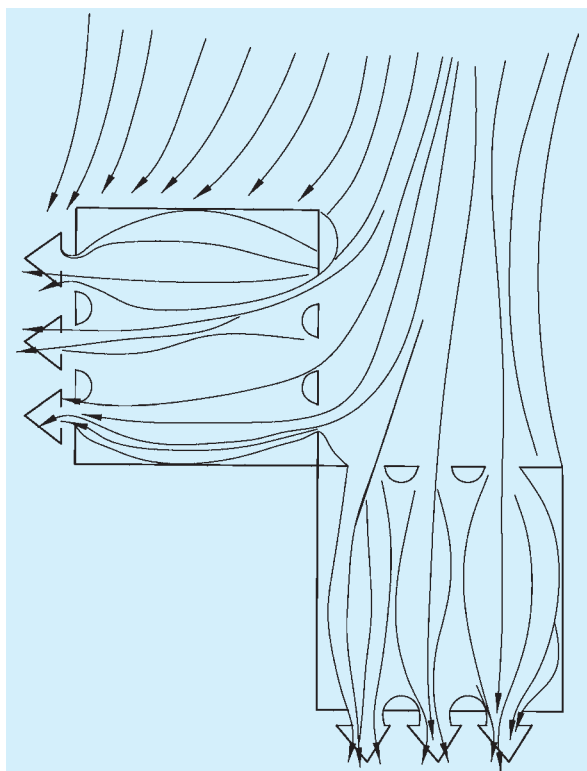

FIG. 9 TWO UNITS LOCATED AT THE END-ON POSITION

- 22) Air motion in a building is not affected by constructing another building of equal or smaller height on the leeward side; but it is slightly reduced if the leeward building is taller than the windward block.
- 23) Air motion in a shielded building is less than that in an unobstructed building. To minimise shielding effect, the distances between two rows should be $8H$ for semi-detached houses and $10H$ for long rows houses. However, for smaller spacing the shielding effect is also diminished by raising the height of the shielded building.
- 24) Hedges and shrubs deflect the air away from the inlet openings and cause a reduction in indoor air motion. These elements should not be planted at a distance of about $8m$ from the building because the induced air motion is reduced to minimum in that case. However, air motion in the leeward part of the building can be enhanced by planting a low hedge at a distance of $2m$ from the building.
- 25) Trees with large foliage mass having trunk bare of branches up to the top level of window, deflect the outdoor wind downwards and promotes air motion in the leeward portion of buildings,
- 26) Ventilation conditions indoors can be ameliorated by constructing buildings on earth

mound having a slant surface with a slope of 10° on upstream side.

- 27) In case of industrial buildings the window height should be about $1.6m$ and width about two-third of wall width. These should be located at a height of $1.1m$ above the floor. In addition to this, openings around $0.9m$ high should be provided over two-third length of the glazed area in the roof lights.
- 28) Height of industrial buildings, although determined by the requirements of industrial processes involved, generally kept large enough to protect the workers against hot stagnant air below the ceiling as also to dilute the concentration of contaminant inside. However, if high level openings in roof or walls are provided, building height can be reduced to $4m$ without in any way impairing the ventilation performance.
- 29) The maximum width up to which buildings of height usually found in factories, being effectively ventilated by natural means by wind action, is $30m$, beyond which sufficient reliance cannot be placed on prevailing winds. Approximately half the ventilating area of openings should be between floor level and a height of $2.25m$ from the floor.

NOTE — For data on outdoor wind speeds at a place, reference may be made to 'The Climatic Data Handbook' prepared by Central Building Research Institute, Roorkee, 1999'.

5.4.3.2 By stack effect

Natural ventilation by stack effect occurs when air inside a building is at a different temperature than air outside. Thus in heated buildings or in buildings wherein hot processes are carried on and in ordinary buildings during summer nights and during pre-monsoon periods, the inside temperature is higher than that of outside, cool outside air will tend to enter through openings at low level and warm air will tend to leave through openings at high level. It would, therefore, be advantageous to provide ventilators as close to ceilings as possible. Ventilators can also be provided in roofs as, for example, cowl, vent pipe, covered roof and ridge vent.

5.5 Mechanical Ventilation

The requirements of mechanical ventilation shall be in accordance with Part 8 'Building Services, Section 3 Air Conditioning, Heating and Mechanical Ventilation' of the Code.

5.6 Determining Rate of Ventilation

5.6.1 Natural Ventilation

This is difficult to measure as it varies from time to

time. The amount of outside air through windows and other openings depends on the direction and velocity of wind outside (wind action) and/or convection effects arising from temperature or vapour pressure differences (or both) between inside and outside of the building (stack effect).

5.6.1.1 Wind action

For determining the rate of ventilation based on wind action the wind may be assumed to come from any direction within 45° of the direction of prevailing wind. Ventilation due to external wind is given by the following formula:

$$Q_w = K.A.V$$

where

- Q_w = rate of air flow, in m³/h;
- K = coefficient of effectiveness, which may be taken as 0.6 for wind perpendicular to openings and 0.3 for wind at an angle less than 45° to the openings;
- A = free area of inlet openings, in m²; and
- V = wind speed, in m/h.

NOTE — For wind data at a place, the local Meteorological Department may be consulted.

5.6.1.2 Stack effect (thermal action)

Ventilation due to convection effects arising from temperature difference between inside and outside is given by:

$$Q_T = 7.0 A \sqrt{h (t_r - t_o)}$$

where

- Q_T = rate of air flow, in m³/h;
- A = free area of inlet openings, in m²;
- h = vertical distance between inlets and outlets, in m;
- t_r = average temperature of indoor air at height h , in °C; and
- t_o = temperature of outdoor air, in °C.

NOTE — The equation is based on 0.65 times the effectiveness of openings. This should be reduced to 0.50, if conditions are not favourable.

5.6.1.3 When areas of inlet and outlet openings are unequal, the value of A may be calculated using the equation:

$$\frac{2}{A^2} = \frac{1}{A_{inlet}^2} + \frac{1}{A_{outlet}^2}$$

5.6.1.4 Combined Effect of Wind and Thermal Action

When both forces (wind and thermal) act together in the same direction, even without interference, the

resulting air flow is not equal to the two flows estimated separately.

When acting simultaneously, the rate of air flow through the building may be computed by the following equation:

$$Q^2 = Q_w^2 + Q_t^2$$

where

- Q = resultant volume of air flow, in m³/min;
- Q_w = volume of air flow due to wind force, in m³/min; and
- Q_t = volume of air flow due to thermal force, in m³/min.

Wind velocity and direction, outdoor temperature, and indoor distribution cannot be predicted with certainty, and refinement in calculation is not justified. A simple method is to calculate the sum of the flows produced by each force separately. Then using the ratio of the flow produced by thermal forces to the aforementioned sum, the actual flow due to the combined forces can be approximated from Fig. 10. When the two flows are equal, the actual flow is about 30 percent greater than the flow caused by either force acting independently (see Fig. 10).

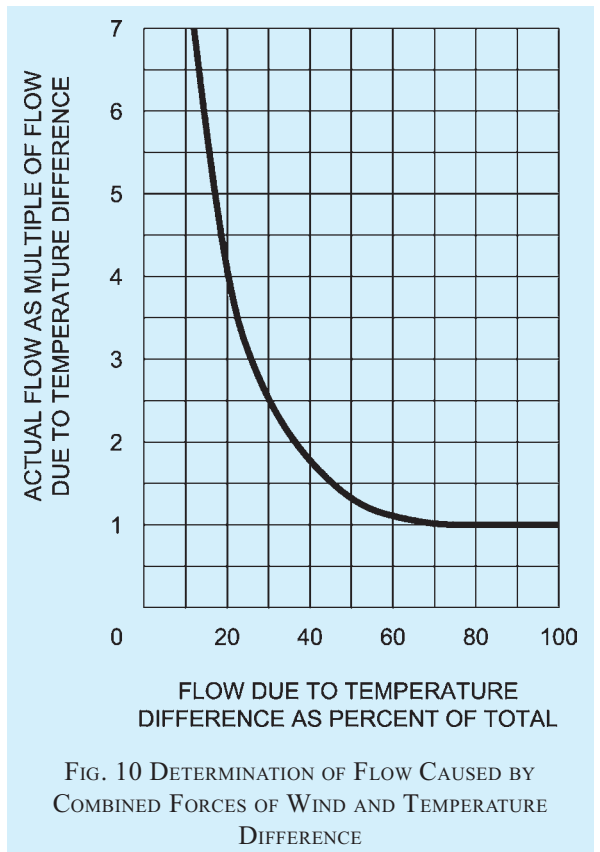

FIG. 10 DETERMINATION OF FLOW CAUSED BY COMBINED FORCES OF WIND AND TEMPERATURE DIFFERENCE

Judgment is necessary for proper location of openings in a building specially in the roof, where heat, smoke and fumes are to be removed. Usually, windward

monitor openings should be closed, but if wind is so slight that temperature head can overcome it, all openings may be opened.

5.6.1.5 For method for determining the rate of ventilation based on probable indoor wind speed with typical illustrative example for residential building, reference may be made to A-4 of good practice [9-1(6)].

5.6.2 Mechanical Ventilation

The determination of rate of ventilation in case of mechanical ventilation shall be done in accordance with Part 8 ‘Building Services, Section 3 Air Conditioning, Heating and Mechanical Ventilation’ of the Code.

5.6.3 Combined effect of Different Methods of Ventilation

When combination of two or more methods of general ventilation is used, the total rate of ventilation shall be reckoned as the highest of the following three, and this rule shall be followed until an exact formula is established by research:

- a) 1.25 times the rate of natural ventilation,
- b) Rate of positive ventilation, and
- c) Rate of exhaust of air.

5.6.4 Measurement of Air Movement

The rate of air movement of turbulent type at the working zone shall be measured either with a Kata thermometer (dry silvered type) or heated thermometer or properly calibrated thermocouple anemometer. Whereas anemometer gives the air velocity directly, the Kata thermometer and heated thermometer give cooling power of air and the rate of air movement is found by reference to a suitable nomogram using the ambient temperature.

5.7 Energy Conservation in Ventilation System

5.7.1 Maximum possible use should be made of wind induced natural ventilation. This may be accomplished by following the design guidelines given in 5.7.1.1.

5.7.1.1 Adequate number of circulating fans should be installed to serve all interior working areas during summer months in the hot dry and warm humid regions to provide necessary air movement at times when ventilation due to wind action alone does not afford sufficient relief.

5.7.1.1.1 The capacity of a ceiling fan to meet the requirement of a room with the longer dimension *D* metre should be about $55D$ m³/min.

5.7.1.1.2 The height of fan blades above the floor should be $(3H + W)/4$, where *H* is the height of the room, and *W* is the height of work plane.

5.7.1.1.3 The minimum distance between fan blades and the ceiling should be about 0.3 m.

5.7.2 Electronic regulators should be used instead of resistance type regulators for controlling the speed of fans.

5.7.3 When actual ventilated zone does not cover the entire room area, then optimum size of ceiling fan should be chosen based on the actual usable area of room, rather than the total floor area of the room. Thus smaller size of fan can be employed and energy saving could be achieved.

5.7.4 Power consumption by larger fans is obviously higher, but their power consumption per square metre of floor area is less and service value higher. Evidently, improper use of fans irrespective of the rooms’ dimensions is likely to result in higher power consumption. From the point of view of energy consumption, the number of fans and the optimum sizes for rooms of different dimensions are given in Table 13.

Table 13 Optimum Size/Number of Fans for Rooms of Different Sizes
(Clause 5.7.4)

Sl No.	Room Width m	Optimum Size, mm/Number of Fans for Room Length											
		4 m	5 m	6 m	7 m	8 m	9 m	10 m	11 m	12 m	14 m	16 m	
(1)	(2)	(3)	(4)	(5)	(6)	(7)	(8)	(9)	(10)	(11)	(12)	(13)	
i)	3	1 200/1	1 400/1	1 500/1	1 050/2	1 200/2	1 400/2	1 400/2	1 400/2	1 400/2	1 200/3	1 400/3	1 400/3
ii)	4	1 200/1	1 400/1	1 200/2	1 200/2	1 200/2	1 400/2	1 400/2	1 500/2	1 200/3	1 400/3	1 500/3	
iii)	5	1 400/1	1 400/1	1 400/2	1 400/2	1 400/2	1 400/2	1 400/2	1 500/2	1 400/3	1 400/3	1 500/3	
iv)	6	1 200/2	1 400/2	900/4	1 050/4	1 200/4	1 400/4	1 400/4	1 500/4	1 200/6	1 400/6	1 500/6	
v)	7	1 200/2	1 400/2	1 050/4	1 050/4	1 200/4	1 400/4	1 400/4	1 500/4	1 200/6	1 400/6	1 500/6	
vi)	8	1 200/2	1 400/2	1 200/4	1 200/4	1 200/4	1 400/4	1 400/4	1 500/4	1 200/6	1 400/6	1 500/6	
vii)	9	1 400/2	1 400/2	1 400/4	1 400/4	1 400/4	1 400/4	1 400/4	1 500/4	1 400/6	1 400/6	1 500/6	
viii)	10	1 400/2	1 400/2	1 400/4	1 400/4	1 400/4	1 400/4	1 400/4	1 500/4	1 400/6	1 400/6	1 500/6	
ix)	11	1 500/2	1 500/2	1 500/4	1 500/4	1 500/4	1 500/4	1 500/4	1 500/4	1 500/6	1 500/6	1 500/6	
x)	12	1 200/3	1 400/3	1 200/6	1 200/6	1 200/6	1 400/6	1 400/6	1 500/6	1 200/7	1 400/9	1 400/9	
xi)	13	1 400/3	1 400/3	1 200/6	1 200/6	1 200/6	1 400/6	1 400/6	1 500/6	1 400/9	1 400/9	1 500/9	
xii)	14	1 400/3	1 400/3	1 400/6	1 400/6	1 400/6	1 400/6	1 400/6	1 500/6	1 400/9	1 400/9	1 500/9	

ANNEX A

(Clause 3.4.1)

METHOD OF CALCULATING SOLAR LOAD ON VERTICAL SURFACES OF DIFFERENT ORIENTATION

A-1 DETAILS OF CALCULATION

A-1.1 The solar energy above the earth's atmosphere is constant and the amount incident on unit area normal to sun's rays is called solar constant (1.360 8 kWm⁻² or 2 cal/cm²/min). This energy, in reaching the earth's surface, is depleted in, the atmosphere due to scattering by air molecules, water vapour, dust particles, and absorption by water vapour and ozone. The depletion varies with varying atmospheric conditions. Another important cause of depletion is the length of path traversed by sun's rays through the atmosphere. This path is the shortest when sun is at the zenith and, as the altitude of the sun decreases, the length of path in the atmosphere increases. Figure 11 gives the computed incident solar energy/hour on unit surface area normal to the rays under standard atmospheric conditions (see Note below) for different altitudes of the sun.

NOTE — The standard atmospheric conditions assumed for this computation are: cloud-free, 300 dust particles per cm³, 15 mm of precipitable water, 2.5 mm of ozone, at sea level.

A-1.2 In order to calculate the solar energy on any surface other than normal to the rays, the altitude of the sun at that time should be known. The corresponding value of direct solar radiation (I_N) should then be found with the help of Fig. 12. The solar radiation incident on any surface (I_S) is given by:

$$I_S = I_N (\sin \beta \sin \phi + \cos \beta \cos \alpha \cos \phi)$$

where

- β = solar altitude,
- ϕ = angle tilt of the surface from the vertical (see Fig. 12), and
- α = wall solar azimuth angle.

A-2 EXAMPLE TO FIND OUT ORIENTATION ON THE BASIS OF SOLAR LOAD

A-2.1 Example

A-2.1.1 As an example, a simple building with flat roof, 10 m × 20 m, and 4 m high is dealt with below. For the sake of generalization, no shading device or verandah is taken.

A-2.1.2 As the roof is horizontal, it will receive the same solar heat in any orientation.

A-2.1.3 The area of the vertical surfaces are 4 m × 10 m = A (say) and 4 m × 20 m = $2A$. Since, the external wall surface are not in shade except when the sun is

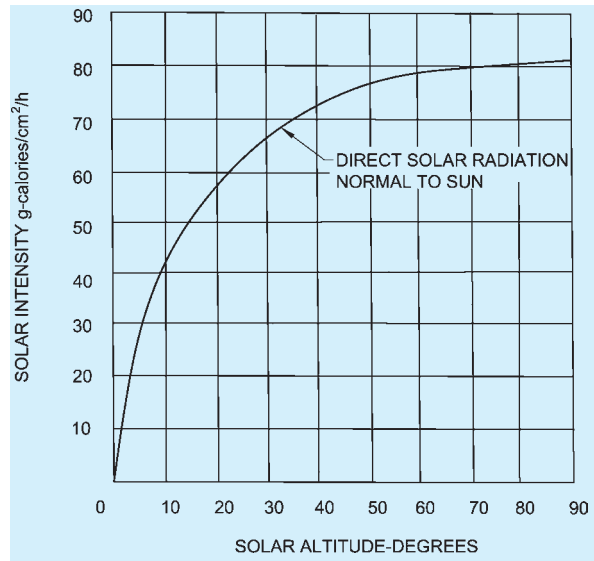

FIG. 11 DIRECT SOLAR INTENSITIES NORMAL TO SUN AT SEA LEVEL FOR STANDARD CONDITION (COMPUTED)

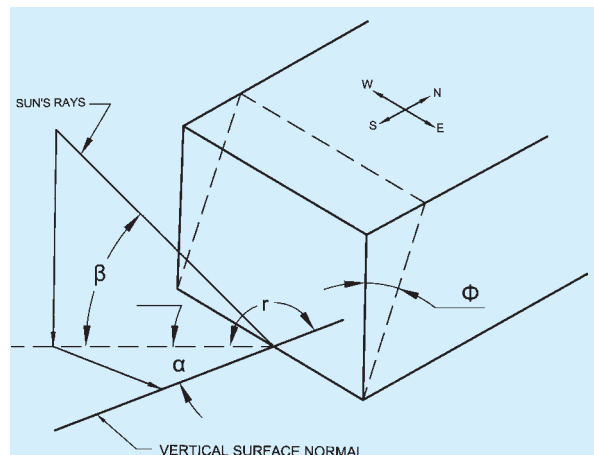

FIG. 12 DEFINITION OF SOLAR ANGLES

not shining on them, the total solar load in a day on a surface can be obtained by multiplying the total load per unit area per day (see Table 3) by the area of the surface. For four principal orientations of the building, the total solar load on the building is worked out in Table 14.

A-2.1.4 From Table 14, it can be seen that for the above type of building, orientation 3 (longer surface facing North and South) is appropriate as it affords maximum solar heat gain in winter and in summer. This is true for all places of India from the point of solar heat gain. By further increasing the length to breadth ratio, the

Table 14 Solar Heat Gained Due to Orientation of Buildings*(Clause A-2.1.3)*

		8° N THIRUVANANTHAPURAM		13° N CHENNAI	
		May 16	Dec 22	May 16	Dec 22
1.	North	$2\,177 \times A = 2\,177A$	—	$1\,625 \times A = 1\,625A$	—
	East	$2\,618 \times 2A = 5\,236A$	$2\,177 \times 2A = 4\,354A$	$2\,697 \times 2A = 5\,394A$	$2\,019 \times 2A = 4\,038A$
	South	—	$4\,164 \times A = 4\,164A$	—	$4\,385 \times A = 4\,385A$
	West	$2\,618 \times 2A = 5\,236A$	$2\,177 \times 2A = 4\,354A$	$2\,697 \times 2A = 5\,394A$	$2\,019 \times 2A = 4\,038A$
	Total	12 649A	12 872A	12 413A	12 461A
2.	NE	$2\,650 \times A = 2\,650A$	$410 \times A = 410A$	$2\,492 \times A = 2\,492A$	$315 \times A = 315A$
	SE	$1\,167 \times 2A = 2\,334A$	$3\,391 \times 2A = 6\,782A$	$1\,341 \times 2A = 2\,682A$	$3\,423 \times 2A = 6\,846A$
	SW	$1\,167 \times 2A = 2\,334A$	$3\,391 \times A = 3\,391A$	$1\,341 \times A = 1\,341A$	$3\,423 \times A = 3\,423A$
	NW	$2\,650 \times 2A = 5\,300A$	$410 \times 2A = 820A$	$2\,492 \times A = 4\,984A$	$315 \times 2A = 630A$
	Total	12 618A	11 403A	11 499A	11 214A
3.	North	$2\,177 \times 2A = 4\,354A$	—	$1\,625 \times 2A = 3\,250A$	—
	East	$2\,618 \times A = 2\,618A$	$2\,177 \times A = 2\,177A$	$2\,697 \times A = 2\,697A$	$2\,019 \times A = 2\,019A$
	South	—	$4\,164 \times 2A = 8\,328A$	—	$4\,385 \times 2A = 8\,770A$
	West	$2\,618 \times A = 2\,618A$	$2\,177 \times A = 2\,177A$	$2\,697 \times A = 2\,697A$	$2\,019 \times A = 2\,019A$
	Total	9 590A	12 602A	8 644A	12 808A
4.	NE	$2\,650 \times 2A = 5\,300A$	—	$2\,492 \times A = 4\,984A$	$315 \times 2A = 630A$
	SE	$1\,167 \times A = 1\,167A$	$2\,177 \times A = 2\,177A$	$1\,341 \times A = 1\,341A$	$3\,423 \times A = 3\,423A$
	SW	$1\,167 \times 2A = 2\,334A$	$4\,164 \times 2A = 8\,328A$	$1\,341 \times 2A = 2\,682A$	$3\,423 \times 2A = 6\,846A$
	NW	$2\,650 \times A = 2\,650A$	$2\,177 \times A = 2\,177A$	$2\,492 \times A = 2\,492A$	$315 \times A = 315A$
	Total	11 451A	12 682A	11 499A	11 214A
		19° N MUMBAI		23° N KOLKATA	
		May 16	Dec 22	May 16	Dec 22
1.	North	$962 \times A = 962A$	—	$741 \times A = 741A$	—
	East	$2\,795 \times 2A = 5\,590A$	$1\,830 \times 2A = 3\,660A$	$2\,871 \times 2A = 5\,742A$	$1\,703 \times 2A = 3\,406A$
	South	—	$4\,574 \times A = 4\,574A$	$205 \times A = 205A$	$4\,637 \times A = 4\,637A$
	West	$2\,795 \times 2A = 5\,590A$	$1\,830 \times 2A = 3\,660A$	$2\,871 \times 2A = 5\,742A$	$1\,703 \times 2A = 3\,406A$
	Total	12 142A	11 894A	12 430A	11 449A
2.	NE	$2\,255 \times A = 2\,255A$	$237 \times A = 237A$	$2\,192 \times A = 2\,192A$	$173 \times A = 173A$
	SE	$1\,640 \times 2A = 3\,280A$	$3\,438 \times 2A = 6\,876A$	$1\,845 \times 2A = 3\,690A$	$3\,454 \times 2A = 6\,908A$
	SW	$1\,640 \times A = 1\,640A$	$3\,438 \times A = 3\,438A$	$1\,845 \times A = 1\,845A$	$3\,454 \times A = 3\,454A$
	NW	$2\,255 \times 2A = 4\,510A$	$237 \times 2A = 474A$	$2\,192 \times 2A = 4\,384A$	$173 \times 2A = 346A$
	Total	11 685A	11 025A	12 111A	10 881A
3.	North	$962 \times 2A = 1\,924A$	—	$741 \times 2A = 1\,482A$	—
	East	$2\,795 \times A = 2\,795A$	$1\,830 \times A = 1\,830A$	$2\,871 \times A = 2\,871A$	$1\,703 \times A = 1\,703A$
	South	—	$4\,574 \times 2A = 9\,148A$	$205 \times 2A = 410A$	$4\,637 \times 2A = 9\,274A$
	West	$2\,795 \times A = 2\,795A$	$1\,830 \times A = 1\,830A$	$2\,871 \times A = 2\,871A$	$1\,703 \times A = 1\,703A$
	Total	7 514A	12 808A	7 634A	12 680A
4.	NE	$2\,255 \times 2A = 4\,510A$	$237 \times 2A = 474A$	$2\,192 \times 2A = 4\,384A$	$173 \times 2A = 346A$
	SE	$1\,640 \times A = 1\,640A$	$3\,438 \times A = 3\,438A$	$1\,845 \times A = 1\,845A$	$3\,454 \times A = 3\,454A$
	SW	$1\,640 \times 2A = 3\,280A$	$3\,438 \times 2A = 6\,876A$	$1\,845 \times 2A = 3\,690A$	$3\,454 \times 2A = 6\,908A$
	NW	$2\,255 \times A = 2\,255A$	$237 \times A = 237A$	$2\,192 \times A = 2\,192A$	$173 \times A = 173A$
	Total	11 685A	11 025A	12 111A	10 881A

Table 14 — (Concluded)

		29° N DELHI	
		May 16	Dec 22
1.	North	$536 \times A = 536A$	—
	East	$2\,950 \times 2A = 5\,900A$	$1\,467 \times 2A = 2\,934A$
	South	$741 \times A = 741A$	$4\,543 \times A = 4\,543A$
	West	$2\,950 \times 2A = 5\,900A$	$1\,467 \times 2A = 2\,934A$
	Total	13 077A	10 411A
2.	NE	$2\,098 \times A = 2\,098A$	$110 \times A = 110A$
	SE	$2\,192 \times 2A = 4\,384A$	$3\,265 \times 2A = 6\,530A$
	SW	$2\,192 \times A = 2\,192A$	$3\,265 \times A = 3\,265A$
	NW	$2\,098 \times 2A = 4\,196A$	$110 \times 2A = 220A$
	Total	12 870A	10 125A
3.	North	$536 \times 2A = 1\,072A$	—
	East	$2\,950 \times A = 2\,950A$	$1\,467 \times A = 1\,467A$
	South	$741 \times 2A = 1\,482A$	$4\,543 \times 2A = 9\,086A$
	West	$2\,950 \times A = 2\,950A$	$1\,467 \times A = 1\,467A$
	Total	8 454A	12 020A
4.	NE	$2\,098 \times 2A = 4\,196A$	$110 \times 2A = 220A$
	SE	$2\,192 \times A = 2\,192A$	$3\,265 \times A = 3\,265A$
	SW	$2\,192 \times 2A = 4\,384A$	$3\,265 \times 2A = 6\,530A$
	NW	$2\,098 \times A = 2\,098A$	$110 \times A = 110A$
	Total	12 870A	10 125A

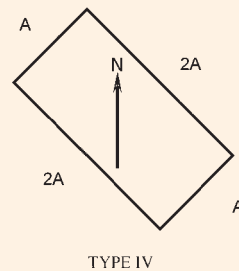
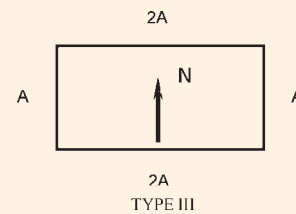
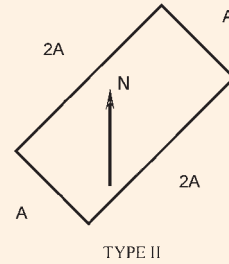
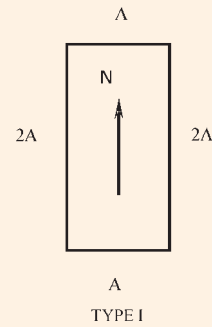

advantage of this orientation will be more pronounced. It may also be noted that in higher altitudes, the relative merit of this orientation is more.

A-2.1.5 It is also seen that the total solar heat on the building is the same for orientation 2 and 4. But if the site considerations require a choice between these two, orientation 2 should be preferred at places north of latitude 23°N and orientation 4 at southern places. This is so because the total solar load per unit area in summer on the north western wall decreases with the increase

in latitude and that on the south western wall increases. It would, therefore, be advantageous to face only smaller surface of the building to greater solar load in the summer afternoons, when the air temperature also is higher.

A-2.1.6 At hill stations, winter season cause more discomfort and so sole criterion for optimum orientation should be based on receiving maximum solar energy on building in winter.

ANNEX B

(Clauses 4.2.5, 4.2.5.2, 4.2.5.4 and 4.2.6.1)

SKY COMPONENT TABLES

B-1 DESCRIPTION OF TABLES

B-1.1 The three sky component tables are as given below:

- a) *Table 15* — Percentage sky components on the horizontal plane due to a vertical rectangular opening for the clear design sky.
- b) *Table 16* — Percentage sky components on the vertical plane perpendicular to a vertical rectangular opening for the clear design sky.
- c) *Table 17* — Percentage sky components on the vertical plane parallel to a vertical rectangular opening for the clear design sky.

B-1.2 All the tables are for an unglazed opening illuminated by the clear design sky.

B-1.3 The values tabulated are the components at a point *P* distant from the opening on a line perpendicular to the plane of the opening through one of its lower corners, and *l* and *h* are the width and height respectively of the rectangular opening (see Fig. 13).

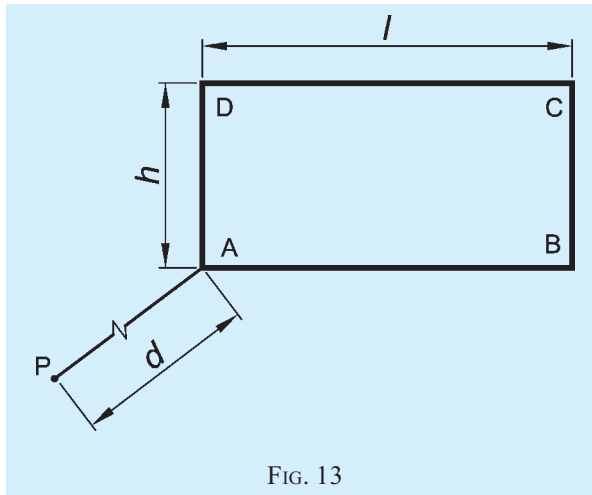

B-1.4 Sky component for different *h/d* and *l/d* values are tabulated, that is, for windows of different size and for different distances of the point *P* from the window.

B-1.5 By suitable combination of the values obtained from the three tables, for a given point for a given window, the sky component in any plane passing through the point may be obtained.

B-1.6 Method of Using the Tables

B-1.6.1 Method of using the Tables to get the sky

component at given point is explained with help of the following example.

B-1.6.2 Example

It is desired to calculate the sky component due to a vertical window ABCD with width 1.8 m and height 1.5 m at a point *P* on a horizontal plane 3.0 m from the window wall located as shown in the Fig. 14. Foot of the perpendicular *N* is 0.6 m below the sill and 0.9 m to the left of *AD*.

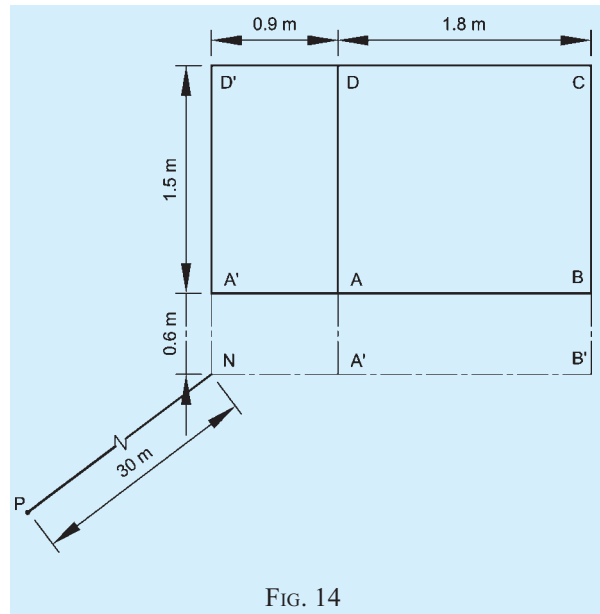

Consider ABCD extended to NB'CD'

- 1) For NB'CD'
 - $l/d = (1.8 + 0.9)/3 = 0.9$
 - $h/d = (1.5 + 0.6)/3 = 0.7$
 - $F_1 = 5.708$ percent (from Table 15)
- 2) For NA'DD'
 - $l/d = 0.9/3 = 0.3$
 - $h/d = (1.5 + 0.6)/3 = 0.7$
 - $F_2 = 2.441$ percent (from Table 15)
- 3) For NB'BA'
 - $l/d = (1.8 + 0.9)/3 = 0.9$
 - $h/d = 0.6/3 = 0.2$
 - $F_3 = 0.878$ percent (from Table 15)
- 4) For NA'AA'
 - $l/d = 0.9/3 = 0.3$
 - $h/d = 0.6/3 = 0.2$
 - $F_4 = 0.403$ percent (from Table 15)

Since $ABCD = NB'CD' - NA'DD' - NB'BA' + NA'AA'$

$$\begin{aligned} \text{Sky Component, } F &= F_1 - F_2 - F_3 + F_4 \\ &= 5.708 - 2.441 - 0.878 + 0.403 \\ &= 2.792 \end{aligned}$$

B-2 GENERAL INSTRUCTIONS

B-2.1 For irregular obstructions like row of trees parallel to the plane of the window, equivalent straight boundaries horizontal and vertical, may be drawn.

B-2.2 For extremely irregular obstruction or obstructions not in a plane parallel to the window, diagrammatic methods, such as Waldrams diagrams may have to be employed.

B-2.3 For bay windows, dormer windows or corner windows the effective dimensions of window opening computed should be taken when using the tables to find the sky components.

B-3 CALCULATION OF IRC

B-3.1 The internal reflected component is a variable quantity which varies from point to point in a room depending upon the interior finish. IRC value is maximum at the centre of the room and decreases elsewhere in all directions. For processing calculations of IRC at any given point of the room, special techniques have to be made out. The internal reflected component may be calculated by using the formula:

$$\text{IRC} = \frac{0.85W}{A(1-R)} (CR_{fw} + 10R_{cw})$$

where

W = window area;

C = constant of value 78 when there is no external obstruction but it has different values as shown in the following table when there are obstructions:

Angle of Obstruction Degree (1)	Sky + External Obstruction, C (2)
5	68.9
15	50.6
25	36.2
35	26.7
45	20.1
55	15.8
65	12.9
75	11.1
85	10.36

R_{fw} = average reflection factor of the floor and those parts of the wall below the plane of the mid-height of the window (excluding the window wall);

R_{cw} = average reflection factor of the ceiling and those parts of the wall above the plane of the mid-height of the window (excluding the window wall);

A = area of all the surfaces in the room (ceiling walls, floor and windows); and

R = average reflection factor of all surfaces in the room (ceiling, walls, floor and windows) expressed as a decimal part of unity.

B-3.2 Example

Consider two rooms of dimensions:

$$\text{Room } X = 6 \text{ m } (l) \times 5 \text{ m } (w) \times 3 \text{ m } (ht)$$

$$\text{Room } Y = 3.7 \text{ m} \times 3 \text{ m} \times 3 \text{ m}$$

Let the window area be 15 percent of the floor area and be glazed.

$$\text{Window size in room } X = 2.5 \text{ m} \times 1.8 \text{ m}$$

$$\text{Window size in room } Y = 3.7 \text{ m} \times 3 \text{ m}$$

The window are on the $Y = 6 \text{ m} \times 3 \text{ m}$ side in room X and $3.7 \text{ m} \times 3 \text{ m}$ side in room Y , and the sill heights are 0.9 m from floor level.

Reflection coefficients of:

walls and ceiling = 70 percent

floor = 20 percent

glazing = 15 percent

Value of IRC in room X :

$$\begin{aligned} \text{a) Total interior area, } A &= 2(30 + 18 + 15) \\ &= 126 \text{ m}^2 \end{aligned}$$

b) Average reflection factor of interior:

$$R = \frac{61.5 \times 0.7 + 30 \times 0.7 + 30 \times 0.2 + 4.5 \times 0.15}{61.5 + 30 + 30 + 4.5} = 0.56$$

$$\text{c) } 1 - R = 0.44$$

d) Mid-height of window is 1.83 m from floor, average reflection factor of room below 1.83 m level excluding the wall containing the window:

$$R_{fw} = \frac{29.28 \times 0.7 + 30 \times 0.2}{29.28 + 30} = 0.45$$

- e) Average reflection factor of room above 1.83 m level excluding the wall containing the window:

$$R_{cw} = \frac{18.72 \times 0.7 + 30 \times 0.7}{18.72 + 30} = 0.7$$

f) $IRC = \frac{0.85 \times 4.5}{126 \times 0.44} (78 \times 0.45 + 10 \times 0.7)$
 $= 2.904$

Value of IRC in room Y:

- a) Total interior area:

$$A = 2(3.7 \times 3 + 3.7 \times 3 + 3 \times 3) = 62.4 \text{ m}^2$$

- b) Average reflection factor:

$$R = \frac{38 \times 55 \times 0.7 \times 3 \times 0.7 + 3.7 \times 3 \times 0.2 + 1.5 \times 1.1 \times 0.15}{38.55 + 11.1 + 11.1 + 1.65} = 0.596$$

- c) Mid-height of window from floor = 1.46 m

- d) Average reflection factor below 1.46 m level

$$R_{fw} = \frac{3.7 \times 3 \times 0.7 + 1.54 \times 9.7 \times 0.7}{11.1 + 14.94} = 0.7$$

- e) Average reflection factor above 1.46 m level

$$R_{cw} = \frac{3.7 \times 3 \times 0.7 + 1.54 \times 9.7 \times 0.7}{11.1 + 14.94} = 0.7$$

f) $IRC = \frac{0.85 \times 1.65}{62.4 \times 0.404} (78 \times 0.48 + 10 \times 0.7)$
 $= 2.472$

B-4 GENERAL NOTE ON DAYLIGHTING OF BUILDING

B-4.1 The main aim of day lighting design is how to admit enough light for good visibility without setting up uncomfortable glare. No simple solution may be

given as the sky varies so much in its brightness from hour to hour, and from season to season.

B-4.2 Different visual tasks need differing amounts of lights for the same visual efficiency. The correct amount of light for any task is determined by the following:

- Characteristics of the tasks* — Size of significant detail, contrast of detail with background and how close it is to the eyes;
- Sight of the worker* — For example, old people need more light;
- Speed and accuracy necessary in the performance of work. If no errors are permissible, much more light is needed; and
- Ease and comfort of working* — Long and sustained tasks shall be done easily whereas workers can make a special effort for tasks of very short duration.

These factors have been made the subject of careful analysis as a result of which tables of necessary levels of illumination have been drawn up.

B-4.3 Levels of lighting determined analytically shall be translated into levels of daylight and then into size of window opening or vice versa for checking the size of window assumed for required levels of daylight.

B-4.4 One of the many important factors involved in the translation is the lightness of the room surface. The illumination levels in a given room with a finite window will be higher when the walls are light coloured than when these are dark coloured. It is necessary, therefore, at an early stage to consider the colouring of the rooms of the building and not to leave this until later. Lighting is not merely a matter of window openings and quite half the eventual level of lighting may be dependent on the decoration in the room. Whatever may be the colour the occupant wants to use, it is most desirable to maintain proper values of reflectance factors for ceiling, wall and floors so that the level of daylight illumination is maintained.

Table 15 Percentage Sky Components on the Horizontal Plane Due to a Vertical Rectangular Opening for the Clear Design Sky
(Clauses B-1.1 and B-1.6.2)

<i>l/d</i>	0.1	0.2	0.3	0.4	0.5	0.6	0.7	0.8	0.9	1.0	1.1	1.2	1.3	1.4	1.5	1.6	1.7	1.8	1.9	2.0	3.0	4.0	5.0	10.0	INF	
<i>h/d</i>	(1)	(2)	(3)	(4)	(5)	(6)	(7)	(8)	(9)	(10)	(11)	(12)	(13)	(14)	(15)	(16)	(17)	(18)	(19)	(20)	(21)	(22)	(23)	(24)	(25)	(26)
0.1	0.036	0.071	0.104	0.133	0.158	0.179	0.198	0.213	0.225	0.235	0.243	0.250	0.256	0.261	0.264	0.268	0.270	0.272	0.274	0.276	0.284	0.286	0.287	0.288	0.288	
0.2	0.141	0.277	0.403	0.516	0.614	0.699	0.770	0.829	0.878	0.918	0.950	0.977	0.999	1.018	1.033	1.046	1.056	1.065	1.072	1.079	1.110	1.118	1.122	1.125	1.125	
0.3	0.300	0.589	0.859	1.102	1.315	1.499	1.653	1.782	1.888	1.976	2.048	2.108	2.157	2.197	2.231	2.259	2.282	2.302	2.318	2.333	2.401	2.421	2.429	2.436	2.437	
0.4	0.460	0.905	1.322	1.702	2.041	2.337	2.590	2.804	2.984	3.134	3.258	3.361	3.446	3.516	3.574	3.623	3.664	3.699	3.728	3.753	3.873	3.909	3.922	3.935	3.937	
0.5	0.604	1.189	1.741	2.247	2.700	3.099	3.444	3.740	3.992	4.204	3.383	4.553	4.659	4.765	4.853	4.928	4.990	5.043	5.088	5.126	5.312	5.366	5.387	5.408	5.410	
0.6	0.732	1.443	2.114	2.732	3.289	3.781	4.211	4.582	4.900	5.171	5.401	5.596	5.761	5.901	6.020	6.121	6.208	6.281	6.344	6.397	6.661	6.739	6.769	6.798	6.802	
0.7	0.844	1.665	2.441	3.159	3.808	4.385	4.891	5.330	5.708	6.034	6.311	6.548	6.751	6.924	7.071	7.198	7.307	7.400	7.481	7.551	7.902	8.006	8.047	8.087	8.092	
0.8	0.942	1.858	2.727	3.532	4.262	4.914	5.488	5.989	6.423	6.798	7.119	7.395	7.632	7.836	8.011	8.162	8.292	8.405	8.502	8.587	9.029	9.164	9.217	9.268	9.276	
0.9	1.026	2.025	2.974	3.855	4.657	5.375	6.011	6.567	7.051	7.470	7.832	8.144	8.413	8.645	8.846	9.019	9.170	9.301	9.415	9.515	10.045	10.214	10.280	10.345	10.355	
1.0	1.099	2.169	3.188	4.135	5.000	5.776	6.465	7.071	7.600	8.060	8.458	8.803	9.102	9.361	9.585	9.780	9.950	10.098	10.228	10.343	10.957	11.162	11.243	11.323	11.335	
1.1	1.161	2.294	3.372	4.377	5.296	6.124	6.861	7.510	8.079	8.576	9.008	9.383	9.709	9.992	10.239	10.454	10.642	10.806	10.951	11.078	11.776	12.017	12.114	12.209	12.224	
1.2	1.215	2.401	3.531	4.586	5.553	6.425	7.204	7.893	8.498	9.027	9.489	9.892	10.243	10.549	10.816	11.050	11.254	11.434	11.593	11.732	12.509	12.786	12.900	13.013	13.030	
1.3	1.262	2.493	3.668	4.767	5.775	6.687	7.503	8.226	8.863	9.422	9.912	10.339	10.713	11.040	11.326	11.577	11.797	11.992	12.163	12.314	13.167	13.478	13.609	13.742	13.762	
1.4	1.302	2.573	3.787	4.924	5.968	6.915	7.764	8.517	9.183	9.769	10.283	10.733	11.127	11.473	11.777	12.044	12.279	12.487	12.670	12.833	13.758	14.102	14.251	14.404	14.427	
1.5	1.337	2.643	3.891	5.060	6.136	7.114	7.991	8.772	9.664	10.073	10.609	11.080	11.493	11.857	12.176	12.458	12.707	12.927	13.122	13.295	14.289	14.666	14.832	15.006	15.033	
1.6	1.367	2.703	3.981	5.179	6.283	7.287	8.190	8.996	9.710	10.341	10.897	11.386	11.817	12.196	12.531	12.826	13.088	13.319	13.525	13.708	14.768	15.176	15.359	15.555	15.585	
1.7	1.394	2.756	4.060	5.283	6.412	7.440	8.366	9.192	9.927	10.577	11.151	11.657	12.104	12.498	12.846	13.154	13.427	13.669	13.885	14.078	15.199	15.638	15.838	16.056	16.091	
1.8	1.417	2.803	4.129	5.375	6.526	7.574	8.520	9.366	10.119	10.786	11.376	11.898	12.359	12.766	13.127	13.446	13.730	13.983	14.208	14.409	15.590	16.058	16.274	16.516	16.554	
1.9	1.438	2.844	4.190	5.456	6.626	7.693	8.656	9.520	10.289	10.972	11.577	12.112	12.587	13.006	13.378	13.708	14.002	14.264	14.498	14.707	15.944	16.441	16.673	16.937	16.980	
2.0	1.456	2.880	4.244	5.527	6.714	7.798	8.778	9.656	10.440	11.137	11.755	12.303	12.789	13.220	13.603	13.943	14.246	14.516	14.758	14.975	16.265	16.790	17.037	17.325	17.372	
3.0	1.559	3.087	4.553	5.937	7.223	8.403	9.478	10.448	11.321	12.103	12.804	13.431	13.993	14.496	14.947	15.353	15.718	16.048	16.346	16.676	18.301	19.051	19.432	19.943	20.046	
4.0	1.600	3.168	4.676	6.100	7.426	8.646	9.759	10.768	11.678	12.498	13.235	13.897	14.493	15.030	15.514	15.951	16.347	16.706	17.033	17.330	19.241	20.142	20.623	21.322	21.495	
5.0	1.620	3.208	4.735	6.179	7.525	8.765	9.897	10.925	11.854	12.693	13.448	14.128	14.742	15.296	15.798	16.252	16.664	17.040	17.382	17.695	19.740	20.740	21.293	22.148	22.393	
10.0	1.648	3.263	4.818	6.289	7.662	8.930	10.089	11.144	12.100	12.965	13.747	14.454	15.094	15.674	16.201	16.681	17.118	17.518	17.885	18.222	20.491	21.681	22.390	23.676	24.238	
INF	1.657	3.282	4.846	6.327	7.710	8.986	10.155	11.220	12.186	13.060	13.851	14.567	15.217	15.806	16.342	16.831	17.278	17.688	18.064	18.410	20.770	22.046	22.838	24.463	26.111	

Table 16 Percentage Sky Components on the Vertical Plane Perpendicular to a Vertical Rectangular Opening for the Clear Design Sky
(Clause B-1.1)

<i>l/d</i> <i>h/d</i>	0.1	0.2	0.3	0.4	0.5	0.6	0.7	0.8	0.9	1.0	1.1	1.2	1.3	1.4	1.5	1.6	1.7	1.8	1.9	2.0	3.0	4.0	5.0	10.0	INF
(1)	(2)	(3)	(4)	(5)	(6)	(7)	(8)	(9)	(10)	(11)	(12)	(13)	(14)	(15)	(16)	(17)	(18)	(19)	(20)	(21)	(22)	(23)	(24)	(25)	(26)
0.1	0.036	0.141	0.303	0.506	0.734	0.971	1.207	1.432	1.643	2.836	1.011	2.168	2.308	2.433	2.544	2.642	2.730	2.808	2.878	2.940	3.309	3.461	3.536	3.641	3.678
0.2	0.071	0.277	0.594	0.993	1.442	1.910	2.374	2.820	3.236	3.618	3.964	4.276	4.554	4.802	5.022	5.219	5.393	5.549	5.688	5.812	6.547	6.850	7.000	7.211	7.284
0.3	0.103	0.401	0.863	1.445	2.100	2.793	3.475	4.180	4.743	5.306	5.818	6.278	6.690	7.058	7.385	7.677	7.936	8.168	8.375	8.560	9.657	10.110	10.335	10.651	10.760
0.4	0.126	0.491	1.059	1.779	2.597	3.460	4.326	5.166	5.958	6.691	7.359	7.967	8.507	8.900	9.420	9.804	10.146	10.451	10.724	10.968	12.421	13.024	13.323	13.743	13.889
0.5	0.142	0.554	1.197	2.015	2.947	3.937	4.938	5.914	6.842	7.707	8.503	9.228	9.883	10.472	10.999	11.476	11.897	12.273	12.610	12.912	14.712	15.462	15.835	16.360	16.542
0.6	0.154	0.600	1.298	2.187	3.204	4.288	5.389	6.468	7.498	8.464	9.358	10.177	10.922	11.596	12.204	12.752	13.244	13.686	14.084	14.441	16.583	17.478	17.924	18.552	18.771
0.7	0.162	0.634	1.372	2.316	3.397	4.552	5.729	6.887	7.997	9.042	10.013	10.907	11.723	12.465	13.138	13.746	14.296	14.793	15.241	15.646	18.111	19.148	19.665	20.397	20.653
0.8	0.169	0.660	1.429	2.413	3.543	4.754	5.990	7.209	8.382	9.490	10.523	11.476	12.350	13.147	13.873	14.531	15.129	15.670	16.161	16.606	19.361	20.538	21.127	21.961	22.253
0.9	0.174	0.680	1.472	2.487	3.655	4.909	6.192	7.460	8.683	9.841	10.924	11.926	12.847	13.690	14.459	15.159	15.796	16.375	16.902	17.381	20.387	21.701	22.360	23.397	23.625
1.0	0.178	0.695	1.505	2.545	3.743	5.030	6.350	7.657	8.921	10.120	11.243	12.284	13.245	14.126	14.931	15.666	16.337	16.948	17.504	18.012	21.237	22.680	23.408	24.446	24.810
1.1	0.181	0.707	1.532	2.591	3.812	5.126	6.475	7.814	9.110	10.342	11.498	12.573	13.556	14.478	15.314	16.079	16.778	17.416	17.999	18.531	21.946	23.508	24.303	25.441	25.841
1.2	0.183	0.716	1.552	2.626	3.866	5.202	6.575	7.939	9.261	10.521	11.705	12.807	13.827	14.766	15.628	16.418	17.141	17.802	18.407	18.961	22.543	24.208	25.072	26.309	26.745
1.3	0.185	0.723	1.568	2.655	3.910	5.263	6.655	8.040	9.384	10.666	11.873	12.998	14.041	15.003	15.887	16.698	17.442	18.123	18.747	19.320	23.049	24.809	25.735	27.070	27.542
1.4	0.186	0.729	1.582	2.678	3.945	5.312	6.720	8.122	9.484	10.785	12.011	13.155	14.217	15.198	16.101	16.931	17.692	18.391	19.032	19.621	23.480	25.326	26.308	27.441	28.249
1.5	0.188	0.734	1.592	2.697	3.973	5.352	6.773	8.189	9.566	10.883	12.124	13.285	14.364	15.361	16.280	17.125	17.902	18.616	19.272	19.875	23.850	25.772	26.808	28.336	28.880
1.6	0.189	0.738	1.601	2.712	3.996	5.385	6.816	8.244	9.634	10.963	12.219	13.394	14.486	15.497	16.430	17.289	18.079	18.806	19.475	20.090	24.169	26.161	27.245	28.866	29.445
1.7	0.189	0.741	1.608	2.724	4.016	5.412	6.852	8.290	9.690	11.031	12.298	13.484	14.589	15.511	16.556	17.427	18.229	18.968	19.648	20.274	24.444	26.501	27.629	29.340	29.955
1.8	0.190	0.744	1.614	2.735	4.032	5.434	6.882	8.328	9.737	11.087	12.364	13.561	14.675	15.708	16.663	17.545	18.357	19.105	19.795	20.431	24.684	26.799	27.969	29.765	30.416
1.9	0.191	0.746	1.619	2.743	4.045	5.453	6.908	8.360	9.777	11.135	12.420	13.625	14.749	15.791	16.755	17.645	18.466	19.224	19.922	20.567	24.893	27.062	28.270	30.149	30.835
2.0	0.191	0.748	1.623	2.751	4.056	5.469	6.929	8.387	9.811	11.175	12.468	13.680	14.811	15.861	16.833	17.731	18.560	19.325	20.031	20.684	25.077	27.294	28.537	30.496	31.217
3.0	0.193	0.756	1.642	2.785	4.109	5.544	7.030	8.517	9.972	11.371	12.699	13.950	15.120	16.211	17.224	18.164	19.036	19.844	20.594	21.289	26.082	28.619	30.108	32.676	32.742
4.0	0.194	0.759	1.648	2.794	4.124	5.566	7.058	8.540	10.018	11.427	12.767	14.029	15.212	16.316	17.343	18.298	19.185	20.008	20.772	21.483	26.439	29.128	30.745	33.687	35.064
5.0	0.194	0.760	1.650	2.798	4.129	5.574	7.069	8.568	10.036	11.449	12.793	14.060	15.248	16.357	17.390	18.351	19.243	20.073	20.844	21.562	26.592	29.359	31.049	34.232	35.872
10.0	0.194	0.761	1.652	2.801	4.135	5.581	7.080	8.582	10.053	11.470	12.818	14.095	15.283	16.398	17.436	18.403	19.302	20.138	20.917	21.641	26.758	29.624	31.419	35.049	37.513
INF	0.194	0.761	1.652	2.802	4.136	5.582	7.081	8.584	10.056	11.473	12.822	14.095	15.288	16.404	17.443	18.411	19.311	20.148	20.928	21.654	26.785	29.672	31.490	35.274	39.172

Table 17 Percentage Sky Components on the Vertical Plane Parallel to a Vertical Rectangular Opening for the Clear Design Sky
(Clause B-1.1)

<i>l/d</i>	0.1	0.2	0.3	0.4	0.5	0.6	0.7	0.8	0.9	1.0	1.1	1.2	1.3	1.4	1.5	1.6	1.7	1.8	1.9	2.0	3.0	4.0	5.0	10.0	INF	
<i>h/d</i>	(1)	(2)	(3)	(4)	(5)	(6)	(7)	(8)	(9)	(10)	(11)	(12)	(13)	(14)	(15)	(16)	(17)	(18)	(19)	(20)	(21)	(22)	(23)	(24)	(25)	(26)
0.1	0.728	1.429	2.078	2.600	3.167	3.660	3.964	4.265	4.513	4.717	4.883	5.020	5.132	5.225	5.301	5.365	5.418	5.463	5.501	5.533	5.687	5.733	5.749	5.765	5.766	
0.2	1.429	2.803	4.007	5.221	6.220	7.073	7.790	8.385	8.876	9.278	9.609	9.880	10.103	10.286	10.439	10.565	10.671	10.760	10.835	10.899	11.207	11.296	11.330	11.362	11.365	
0.3	2.068	4.061	5.913	7.580	9.040	10.285	11.337	12.212	12.934	13.528	14.016	14.417	14.747	15.020	15.246	15.434	15.591	15.724	15.836	15.931	16.390	16.523	16.574	16.623	16.627	
0.4	2.529	4.970	7.249	9.312	11.133	12.707	14.042	15.164	16.097	16.870	17.507	18.025	18.458	18.816	19.113	19.360	19.568	19.742	19.890	20.015	20.624	20.801	20.868	20.933	20.939	
0.5	2.852	5.608	8.186	10.529	12.606	14.401	15.952	17.256	18.350	19.262	20.021	20.652	21.177	21.613	21.978	22.275	22.530	22.746	22.923	23.082	23.836	24.056	24.140	24.222	24.229	
0.6	3.086	6.070	8.867	11.415	13.681	15.656	17.353	18.793	20.008	21.027	21.879	22.592	23.189	23.689	24.109	24.462	24.761	25.014	25.229	25.412	26.229	26.561	26.662	26.759	26.768	
0.7	3.259	6.413	9.373	12.074	14.482	16.588	18.402	19.949	21.257	22.359	23.285	24.063	24.716	25.267	25.731	26.124	26.458	26.742	26.984	27.192	28.214	28.517	28.634	28.748	28.758	
0.8	3.389	6.672	9.755	12.573	15.090	17.296	19.201	20.830	22.212	23.380	24.365	25.195	25.895	26.486	26.987	27.412	27.775	28.084	28.350	28.578	29.720	30.065	30.198	30.327	30.339	
0.9	3.489	6.869	10.046	12.955	15.556	17.840	19.817	21.511	22.952	24.173	25.206	26.078	26.816	27.441	27.972	28.424	28.810	29.141	29.426	29.672	30.927	31.303	31.451	31.596	31.610	
1.0	3.565	7.024	10.272	13.250	15.917	18.263	20.297	22.043	23.531	24.795	25.866	26.773	27.542	28.196	28.572	29.226	29.633	29.982	30.283	30.544	31.889	32.302	32.467	32.627	32.643	
1.1	3.625	7.139	10.447	13.481	16.200	18.594	20.674	22.462	23.989	25.288	26.391	27.326	28.121	28.798	29.375	29.869	30.293	30.658	30.973	31.246	32.670	33.117	33.297	33.473	33.491	
1.2	3.672	7.233	10.586	13.663	16.423	18.857	20.973	22.795	24.353	25.681	26.810	27.770	28.587	29.283	29.878	30.388	30.826	31.204	31.532	31.816	33.309	33.796	33.981	34.173	34.193	
1.3	3.709	7.307	10.696	13.807	16.602	19.067	21.213	23.062	24.646	25.998	27.148	28.128	28.963	29.676	30.286	30.810	31.261	31.651	31.989	32.283	33.836	34.350	34.550	34.756	34.779	
1.4	3.739	7.366	10.784	13.924	16.745	19.236	21.406	23.278	24.884	26.255	27.424	28.420	29.271	29.998	30.621	31.157	31.618	32.018	32.365	32.667	34.374	34.813	35.035	35.247	35.271	
1.5	3.763	7.414	10.856	14.018	16.861	19.373	21.563	23.454	25.077	26.465	27.649	28.660	29.523	30.262	30.897	31.443	31.914	32.322	32.677	32.986	34.641	35.202	35.436	35.663	35.689	
1.6	3.783	7.453	10.914	14.095	16.956	19.485	21.692	23.599	25.236	26.638	27.835	28.857	29.732	30.482	31.226	31.680	32.160	32.575	32.937	33.253	34.950	35.532	35.776	36.017	36.046	
1.7	3.799	7.485	10.962	14.158	17.034	19.578	21.798	23.718	25.368	26.781	27.989	29.022	29.906	30.665	31.317	31.879	32.366	32.888	33.156	33.477	35.211	35.812	36.067	36.321	36.352	
1.8	3.812	7.512	11.002	14.211	17.099	19.655	21.886	23.817	25.478	26.900	28.118	29.160	30.052	30.818	31.477	32.046	32.539	32.967	33.340	33.666	35.435	36.052	36.316	36.584	36.617	
1.9	3.824	7.534	11.035	14.254	17.153	19.719	21.960	23.900	25.570	27.001	28.226	29.276	30.175	30.948	31.613	32.188	32.686	33.119	33.497	33.828	35.626	36.259	36.532	36.812	36.847	
2.0	3.833	7.553	11.062	14.291	17.199	19.773	22.022	23.970	25.647	27.086	28.318	29.374	31.279	31.058	31.728	32.308	32.811	33.249	33.631	33.965	35.791	36.438	36.719	37.011	37.048	
3.0	3.876	7.639	11.192	14.463	17.412	20.027	22.316	24.302	26.016	27.491	28.757	29.846	30.783	31.592	32.291	32.898	33.427	33.889	34.294	34.551	36.640	37.380	37.715	38.107	38.157	
4.0	3.888	7.663	11.228	14.511	17.471	20.098	22.398	24.398	26.121	27.606	28.884	29.983	30.930	31.748	32.457	33.074	33.611	34.082	34.496	34.860	36.915	37.699	38.063	38.510	38.579	
5.0	3.893	7.672	11.241	14.529	17.494	20.125	22.430	24.432	26.161	27.650	28.932	30.035	30.986	31.808	32.521	33.142	33.683	34.157	34.574	34.943	37.028	37.834	38.214	38.696	38.781	
10.0	3.897	7.681	11.254	14.546	17.515	20.150	22.459	24.466	26.199	27.693	28.978	30.085	31.041	31.867	32.584	33.208	33.753	34.231	34.652	35.024	37.144	37.978	38.382	38.927	39.057	
INF	3.898	7.682	11.256	14.548	17.518	20.154	22.464	24.471	26.205	27.699	28.985	30.093	31.049	31.876	32.593	33.218	33.764	34.243	34.664	35.037	37.162	38.003	38.411	38.978	39.172	

LIST OF STANDARDS

The following list records those standards which are acceptable as 'good practice' and 'accepted standards' in the fulfillment of the requirements of the Code. The latest version of a standard shall be adopted at the time of enforcement of the Code. The standards listed may be used by the Authority for conformance with the requirements of the referred clauses in the Code.

In the following list, the number appearing in first column within parentheses indicates the number of the reference in this Section.

<i>IS No.</i>	<i>Title</i>	<i>IS No.</i>	<i>Title</i>
		7942 : 1976	Code of practice for daylighting of educational buildings
(5)	1944		Code of practice for lighting of public thoroughfares:
		(Parts 1 and 2) : 1970	Parts 1 and 2 For main and secondary roads (Group A and B) (<i>first revision</i>)
		Part 6 : 1981	Lighting for town and city centres and areas of civic importance (Group E)
		2672 : 1966	Code of practice for library lighting
(1)	7662 (Part 1) : 1974	4347 : 1967	Code of practice for hospital lighting
	Recommendations for orientation of buildings: Part 1 Non-industrial buildings	6074 : 1971	Functional requirements of hotels, restaurants and other food service establishments
(2)	3646 (Part 1) : 1992	6665 : 1972	Code of practice for industrial lighting
	Code of practice for interior illumination: Part 1 General requirements and recommendations for building interiors (<i>first revision</i>)	10894 : 1984	Code of practice for lighting of educational institutions
(3)	2440 : 1975	10947 : 1984	Code of practice for lighting for ports and harbours
	Guide for daylighting of buildings (<i>second revision</i>)	(6)	3362 : 1977
(4)	6060 : 1971		Code of practice for natural ventilation of residential buildings (<i>first revision</i>)
	Code of practice for daylighting of factory buildings		

NATIONAL BUILDING CODE OF INDIA

PART 8 BUILDING SERVICES

Section 2 Electrical and Allied Installations

BUREAU OF INDIAN STANDARDS

CONTENTS

FOREWORD	... 3
1 SCOPE	... 7
2 TERMINOLOGY AND CONVENTIONAL SYMBOLS	... 7
3 GENERAL REQUIREMENTS	... 17
4 PLANNING OF ELECTRICAL INSTALLATIONS	... 18
5 DISTRIBUTION OF SUPPLY AND CABLING	... 30
6 WIRING	... 47
7 FITTINGS AND ACCESSORIES	... 56
8 EARTHING	... 61
9 INSPECTION, TESTING AND VERIFICATION OF INSTALLATION	... 72
10 ALLIED/MISCELLANEOUS SERVICES	... 77
11 LIGHTNING PROTECTION OF BUILDINGS	... 81
12 ELECTRICAL INSTALLATIONS FOR CONSTRUCTION AND DEMOLITION SITES	...111
13 PROTECTION OF HUMAN BEINGS FROM ELECTRICAL HAZARDS	...118
ANNEX A DRAWING SYMBOLS FOR ELECTRICAL INSTALLATIONS IN BUILDINGS	...124
ANNEX B EXTRACTS FROM CENTRAL ELECTRICITY AUTHORITY (MEASURES RELATING TO SAFETY AND ELECTRIC SUPPLY) REGULATION, 2010 FURTHER AMENDED IN 2015	...129
ANNEX C AREA REQUIRED FOR TRANSFORMER ROOM AND SUBSTATION FOR DIFFERENT CAPACITIES	...150
ANNEX D ADDITIONAL AREA REQUIRED FOR GENERATOR IN ELECTRIC SUBSTATION	...150
ANNEX E CHECKLIST FOR INSPECTION, HANDING OVER AND COMMISSIONING OF VARIOUS EQUIPMENT OF SUBSTATION	...151
ANNEX F CHECKLIST FOR INSPECTION, HANDING OVER AND COMMISSIONING OF EARTHING PITS	...161
ANNEX G FORM OF COMPLETION CERTIFICATE	...163
LIST OF STANDARDS	...166

FOREWORD

This Code (Part 8/Section 2) covers essential requirements for electrical and allied installations in buildings.

This Section was first published in 1970 and was subsequently revised in 1983 and 2005. In the first revision, general guidance for electrical wiring installation in industrial location where voltage supply normally exceeds 650 V was included. This Section was also updated based on the existing version of the Indian Standards. The importance of pre-planning and exchange of information among all concerned agencies from the earlier stages of building work was emphasized.

In the second revision of 2005, the title of this Section was modified from the erstwhile ‘Electrical Installations’ to ‘Electrical and Allied Installations’ to reflect the provisions included on certain allied installations. The significant changes incorporated in the last revision included, thorough change in the risk assessment procedure for lightning including some other changes in the provision of lightning protection of building; alignment of some of the provisions of wiring with the practices prevalent at that time; modification of definitions in line with terminologies used at national and international level and addition of some new definitions; incorporation of provisions on installation of distribution transformer inside the multi-storeyed building; introduction of concept of energy conservation in lighting and introduction of concept of various types of earthing in building installation.

All electrical installations in India come under the purview of *The Indian Electricity Act, 2003* and the rules and regulations framed thereunder. In the context of the buildings, both buildings (the structure itself) and the building services (not just the electrical services, but all other services that use electricity or have an interface with the electrical system) are required to follow these. The erstwhile *Indian Electricity Rules, 1956* were superseded by various Central Electricity Authority Regulations. While revising the provisions of this Section of the Code, care has been taken to align the same with the provisions of the relevant regulations, particularly, *Central Electricity Authority (Measures Relating to Safety and Electric Supply) Regulations, 2010*, amended in 2015. In this revision, in addition to above, the following major modifications have been incorporated:

- a) Various new terms and their definitions have been added and existing terms and definitions have also been updated based on current developments at national and international level.
- b) Provisions relating to location and other requirements relating to layout, environmental and safety aspects for different substation apparatus/equipment and generating sets have been reviewed and updated.
- c) Provisions relating to location of compact substations have been added.
- d) Requirements for electrical supply system for life and safety services have been included.
- e) Provisions relating to reception and distribution of supply and wiring installations have been updated with due cognizance to Indian Standards formulated for various wiring systems.
- f) Provisions relating to installation of energy meters have been updated.
- g) Discrimination, cascading and limitation concepts for the coordination of protective devices in electrical circuits have been introduced.
- h) Socket outlets with suitable circuit breakers, conforming to following Indian Standards have been recommended for industrial and commercial applications, either indoors or outdoors:
 - 1) IS/IEC 60309-1:2002 ‘Plugs, socket-outlets and couplers for industrial purposes — Part 1: General requirements’; and
 - 2) IS/IEC 60309-2:2002 ‘Plugs, socket-outlets and couplers for industrial purposes — Part 2: Dimensional Interchangeability Requirements for Pin and Contact-Tube Accessories’.
- j) Provisions relating to earthing/grounding have been substantially revised and updated.
- k) Provisions relating to lightning protection of buildings have been revamped based on the current national and international developments.
- m) Provisions relating to renewable energy sources for building, such as solar PV system; aviation obstacle

- lights; electrical supply for electric vehicle charging and car park management; etc, have been included.
- n) New provisions relating to electrical installations for construction sites and demolition sites have been included.
 - p) New provisions relating to protection of human beings from electrical hazards and protection against fire in the building due to leakage current have been included.
 - q) Typical formats for checklists for handing over and commissioning of substation equipment and earthing pit have been included.

This Section has to be read together with Part 8 'Building Services, Section 1 Lighting and Natural Ventilation' of the Code for making provision for the desired levels of illumination as well as ventilation for different locations in different occupancies; and also with Part 4 'Fire and Life Safety' of the Code for list of emergency fire and life safety services and other sections of Part 8 'Building Services' and Part 9 'Plumbing Services' for electricity related requirements and integration thereof. Utmost importance should be given in the installation of electrical wiring to prevent short circuiting and the hazards associated therewith.

Notwithstanding the provisions given in this Section and the National Electrical Code, 2011 the provisions of the *Indian Electricity Act, 2003* and the rules and regulations framed thereunder have to be necessarily complied with.

The information contained in this Section is largely based on the following Indian Standards/Special Publication:

IS 732 : 1989	Code of practice for electrical wiring installations (<i>third revision</i>) (<i>under revision</i>)
IS 3043 : 1987	Code of practice for earthing (<i>first revision</i>) (<i>under revision</i>)
IS 4648: 1968	Guide for electrical layout in residential buildings
IS 12032 (Part 11) : 1987	Specification for graphical symbols for diagrams in the field of electro technology: Part 11 Architectural and topographical installation plan and diagrams
IS/IEC 62305-1 : 2010	Protection against lightning: Part 1 General principles
IS/IEC 62305-2 : 2010	Protection against lightning: Part 2 Risk management
IS/IEC 62305-3 : 2010	Protection against lightning: Part 3 Physical damage to structures and life hazard
IS/IEC 62305-4 : 2010	Protection against lightning: Part 4 Electrical and electronic systems within structures
SP 30 : 2011	National Electrical Code, 2011 (<i>first revision</i>)

It may be noted that some of the above standards are currently under revision. The revised version when available should also be referred.

Considerable assistance has also been drawn from following International Standards while formulating this Section:

IEC 60364-4-41 : 2005	Low-voltage electrical installations — Part 4-41: Protection for safety — Protection against electric shock
IEC 60364-4-43 : 2008	Low-voltage electrical installations — Part 4-43: Protection for safety — Protection against overcurrent
IEC 60364-4-44 : 2007	Low-voltage electrical installations — Part 4-44: Protection for safety — Protection against voltage disturbances and electromagnetic disturbances
IEC 60364-5-51 : 2005	Electrical installations of buildings — Part 5-51: Selection and erection of electrical equipment — Common rules
IEC 60364-5-54 : 2011	Low-voltage electrical installations — Part 5-54: Selection and erection of electrical equipment — Earthing arrangements and protective conductors
IEC 60364-7 series	Low-voltage electrical installations — Part 7: Requirements for special installations or locations
IEC 61439-1 : 2011	Low-voltage switchgear and controlgear assemblies and bus trunking — Part 1: General rules
IEC 61439-2 : 2011	Low-voltage switchgear and controlgear assemblies and bus trunking — Part 2: Power switchgear and controlgear assemblies
IEC 61439-6 : 2012	Low-voltage switchgear and controlgear assemblies and bus trunking — Part 6: Busbar trunking systems (busways)

All standards, whether given herein above or cross-referred to in the main text of this Section, are subject to revision. The parties to agreement based on this Section are encouraged to investigate the possibility of applying the most recent editions of the standards.

For the purpose of deciding whether a particular requirement of this Section is complied with, the final value, observed or calculated, expressing the result of a test or analysis, shall be rounded off in accordance with IS 2 : 1960 'Rules for rounding off numerical values (*revised*)'. The number of significant places retained in the rounded off value should be the same as that of the specified value in this Section of the Code.

NATIONAL BUILDING CODE OF INDIA

PART 8 BUILDING SERVICES

Section 2 Electrical and Allied Installations

1 SCOPE

This Code (Part 8/Section 2) covers the essential requirements for electrical installations in buildings to ensure efficient use of electricity including safety from fire and shock. This Section also includes general requirements relating to lightning protection of buildings and brief provisions on certain allied installations.

2 TERMINOLOGY AND CONVENTIONAL SYMBOLS

2.1 For the purpose of this Section, the following definitions shall apply. For definition of other terms, reference may be made to accepted standards [8-2(1)].

2.1.1 Accessory — A device, other than current using equipment, associated with such equipment or with the wiring of an installation.

2.1.2 Apparatus — Electrical apparatus including all machines, appliances and fittings in which conductors are used or of which they form a part.

2.1.3 Appliance — An item of current using equipment other than a luminaire or an independent motor.

2.1.4 Back-up Protection — Protection which is intended to operate when a system fault is not cleared or abnormal condition not detected in the required time, because of failure or inability of other protection to operate or failure of appropriate circuit-breaker to trip.

2.1.5 Barrier — A part providing a defined degree of protection against contact with live parts, from any usual direction of access.

2.1.6 Basic Protection — Protection against electric shock under fault-free condition.

NOTE — For low voltage installations, systems and equipment, basic protection generally corresponds to protection against direct contact that is 'contact of persons or live parts'.

2.1.7 Bonding Conductor — A protective conductor providing equipotential bonding.

2.1.8 Bonding Ring Conductor (BRC) — A bus earthing conductor in the form of a closed ring.

NOTE — Normally the bonding ring conductor, as part of the bonding network, has multiple connections to the common bonding network (CBN) that improves its performance.

2.1.9 Bunched — Cables are said to be 'bunched' when two or more are contained within a single conduit, duct, ducting, or trunking, or, if not enclosed, are not separated from each other.

2.1.10 Buried Direct — A cable laid in the ground in intimate contact with the soil.

2.1.11 Busbar Trunking System — A type-tested assembly, in the form of an enclosed conductor system comprising solid conductors separated by insulating materials. The assembly may consist of units such as:

- a) Busbar trunking units, with or without tap-off facilities;
- b) Tap-off units where applicable; and
- c) Phase-transposition, expansion, building-movement, flexible, end-feeder and adaptor units.

2.1.12 Bypass Equipotential Bonding Conductor — Bonding conductor connected in parallel with the screens of cables.

2.1.13 Cable — A length of single-insulated conductor (solid or stranded), or two or more such conductors, each provided with its own insulation, which are laid up together. The insulated conductor or conductors may or may not be provided with an overall mechanical protective covering.

2.1.14 Cable, Circuit Integrity — A cable which continues to function, that is, maintains the continuity of the circuit under circumstances of fire (against a specified temperature and period of the test).

NOTE — For circuit integrity cable requirements reference may be made to accepted standard [8-2(2)], which prescribes a fire survival test at 750°C for 3 h.

2.1.15 Cable, Flame Retardant (FR) — A cable which is flame retardant as per the accepted standard [8-2(3)].

2.1.16 Cable, Flame Retardant Low Smoke and Halogen (FR-LSH) — A cable which is flame retardant and emits low smoke and halogen as per the accepted standard [8-2(3)].

2.1.17 Cable, Flexible — A cable containing one or more cores, each formed of a group of wires, the diameters of the cores and of the wires being sufficiently small to afford flexibility.

2.1.18 Cable, Metal-Sheathed — An insulated cable with a metal sheath.

2.1.19 Cable, PVC Sheathed-Insulated — A cable in which the insulation of the conductor is a polyvinylchloride (PVC) compound; with PVC sheath also providing mechanical protection to the conductor core or cores in the cable.

2.1.20 Cable, Weatherproof — A cable so constructed that when installed in uncovered locations, it will withstand all kinds of weather variations (see 2.1.186 for definition of weatherproof).

2.1.21 Cable, XLPE — A cable in which the insulation of the conductor is cross-linked polythene and the mechanical protection is provided for the core or cores by a sheath of a polyvinyl chloride compound.

2.1.22 Cable Armoured — A cable provided with a wrapping of metal (usually in the form of tape or wire) serving as a mechanical protection.

2.1.23 Cable Bracket — A cable support consisting of single devices fixed to elements of building or plant construction.

2.1.24 Cable Channel — An enclosure situated above or in the ground, open or ventilated or closed, and having dimensions which do not permit the access of persons but allow access to the conductor and/or cables throughout their length during and after installation.

NOTE — A cable channel may or may not form part of the building construction.

2.1.25 Cable Cleat — A component of a support system which consists of elements spread at intervals along the length of the cable or conduits and which mechanically retains the cable or conduit.

2.1.26 Cable Coupler — A means enabling the connection, at will, of two flexible cables. It consists of a connector and a plug.

2.1.27 Cable Ducting — A manufactured enclosure of metal or insulating material, other than conduit or cable trunking, intended for the protection of cables which are drawn-in after erection of the ducting, but which is not specifically intended to form part of a building structure.

2.1.28 Cable Ladder — A cable support occupying less than 10 percent of the plan area and consisting of a series of supporting elements rigidly fixed to each other or to a main supporting member or members.

2.1.29 Cable Raceways — An enclosed channel of metal or non-metallic materials designed expressly for holding wires, cables or busbars, with openable/maintainable construction having provision of ventilation. These include electrical non-metallic tubing, electrical metallic tubing, underfloor raceways, cellular concrete floor raceways, cellular metal floor raceways, surface raceways and wireways.

2.1.30 Cable Tray — A cable support consisting of a continuous base with raised edges and no covering. A cable tray is considered to be non-perforated, where less than 30 percent of the material is removed from the base.

2.1.31 Cable Trunking — A factory made closed support and protection system into which conductors and/or cables are laid after removal of the cover.

2.1.32 Cable Tunnel — An enclosure (corridor) containing supporting structures for conductors and/or cables and joints and whose dimensions allow free access to persons throughout the entire length.

2.1.33 Cartridge Fuse Link — A device comprising a fuse element or several fuse elements connected in parallel enclosed in a cartridge usually filled with an arc-extinguishing medium and connected to terminations. The fuse link is the part of a fuse which requires replacing after the fuse has operated.

2.1.34 Ceiling Rose — A fitting (usually used to attach to the ceiling) designed for the connection between the electrical installation wiring and a flexible cord (which is in turn connected to a lampholder).

2.1.35 Circuit — An assembly of electrical equipment supplied from the same origin and protected against overcurrent by the same protective device(s). Circuits are categorized as follows:

- a) *Category 1 circuit* — A circuit (other than a fire alarm annunciation or emergency lighting circuit and other circuits required to work during fire in a building) operating at low voltage and supplied directly from a mains supply system.
- b) *Category 2 circuit* — With the exception of Category 3 circuits, any circuit for extra low-voltage (ELV)/telecommunication [for example, radio, telephone, sound distribution, building management system (BMS), public address system (PAS), intruder alarm, bell and call and data transmission circuits] which is supplied from a safety source.
- c) *Category 3 circuit* — A fire alarm circuit or an emergency lighting circuit and other circuits required to work during fire in a building.

2.1.36 Circuit Breaker — A mechanical switching device, capable of making, carrying and breaking currents under normal circuit conditions and also of making, carrying for a specified time, and breaking currents under specified abnormal circuit conditions such as those of short circuit.

NOTE — A circuit breaker is usually intended to operate infrequently, although some types are suitable for frequent operation.

2.1.36.1 Miniature circuit breaker (MCB) — A compact mechanical switching device capable of making, carrying and breaking currents under normal circuit conditions and also making and carrying currents for specified times and automatically breaking currents

under specified abnormal circuit conditions, such as those of overload and short circuits.

2.1.36.2 *Circuit breaker, linked* — A circuit breaker, the contacts of which are so arranged as to make or break all poles simultaneously or in a definite sequence.

2.1.36.3 *Moulded case circuit breaker (MCCB)* — A circuit breaker having a supporting housing of moulded insulating material forming an integral part of the circuit breaker.

2.1.36.4 *Air circuit breaker (ACB)* — A circuit breaker in which the contacts open and close in air at atmospheric pressure.

2.1.36.5 *Residual current operated circuit breaker* — A mechanical switching device designed to make, carry and break currents under normal service conditions and to cause the opening of the contacts when the residual current attains a given value under specified conditions.

2.1.36.5.1 *Residual current operated circuit breaker with integral overcurrent protection (RCBO)* — A residual current operated circuit breaker designed to perform the functions of protection against overload and/or short-circuit.

2.1.36.5.2 *Residual current operated circuit breaker without integral overcurrent protection (RCCB)* — A residual current operated circuit breaker not designed to perform the functions of protection against overload and/or short-circuits.

NOTE — Similar function is provided by earth leakage circuit breaker (ELCB).

2.1.37 *Circuit, Final Sub* — An outgoing circuit connected to one-way distribution board and intended to supply electrical energy at one or more points to current, using appliances without the intervention of a further distribution board other than a one-way board. It includes all branches and extensions derived from that particular way in the board.

2.1.38 *Circuit Integrity Cable Support and Fixing Materials* — Supports and fixing materials for supporting circuit integrity cable (see 2.1.14), which continues in service after exposure to fire for a specified duration.

2.1.39 *Compact Substation or Prefabricated Substation* — Prefabricated and type-tested assembly which can be operated from inside (walk-in type) or outside (non-walk-in type) comprising components such as power transformer, high-voltage switchgear and controlgear, low-voltage switchgear and controlgear, corresponding interconnections (cable, busbar or other) and-auxiliary equipment and circuits located next to each other, maintaining segregation and integrity of each compartment in which they are located along with

external interconnecting cables, earthing, protections, etc. The components shall be enclosed, by either a common enclosure or by an assembly of enclosures.

NOTE — See accepted standard [8-2(4)] for requirements of prefabricated substation.

2.1.40 *Conductor of a Cable or Core* — The conducting portion consisting of a single wire or group of wires, assembled together and in contact with each other or connected in parallel.

2.1.41 *Conductor, Aerial* — Any conductor which is supported by insulators above the ground and is directly exposed to the weather.

NOTE — Following four classes of aerial conductors are recognized:

- a) Bare aerial conductors,
- b) Covered aerial conductors,
- c) Insulated aerial conductors, and
- d) Weatherproof neutral-screened cable.

2.1.42 *Conductor, Bare* — A conductor not covered with insulating material.

2.1.43 *Conductor, Earthed* — A conductor with no provision for its insulation from earth.

2.1.44 *Conductor, Insulated* — A conductor adequately covered with insulating material of such quality and thickness as to prevent danger.

2.1.45 *Conduit* — A part of a closed wiring system, a circular or non-circular cross-section for conductors and/or cables in electrical installations, allowing them to be drawn in and/or replaced. Conduits should be sufficiently closed-jointed so that the conductors can only be drawn in and not inserted laterally.

2.1.46 *Connector* — The part of a cable coupler or of an appliance coupler which is provided with female contact and is intended to be attached to the flexible cable connected to the supply.

2.1.47 *Connector Box or Joint Box* — A box forming a part of wiring installation, provided to contain joints in the conductors of cables of the installations.

2.1.48 *Connector for Portable Appliances* — A combination of a plug and socket arranged for attachment to a portable electrical appliance or to a flexible cord.

2.1.49 *Consumer's Terminals* — The ends of the electrical conductors situated upon any consumer's premises and belonging to him, at which the supply of energy is delivered from the service line.

2.1.50 *Continuous Operating Voltage (U_c)* — Maximum rms voltage which may be continuously applied to a surge protection device's mode of protection. This is equal to rated voltage.

2.1.51 Cord, Flexible — A flexible cable having a large number of (typically 16 or 23 or 46 or 89, etc) strands of conductors of small cross-sectional area. Two flexible cords twisted together are known as twin 'flexible cord'.

NOTE — Large number of fine strands of wires for each conductor makes the conductor capable of withstanding frequent bends thereby improving their flexibility.

2.1.52 Core of a Cable — A single conductor of a cable with its insulation but not including any mechanical protective covering.

2.1.53 Current Carrying Capacity of a Conductor — The maximum current which can be carried by a conductor under specified conditions without its steady state temperature exceeding a specified value.

2.1.54 Current Using Equipment — Equipment which converts electrical energy in to another form of energy, such as light, heat, or motive power.

2.1.55 Cut-out — Any appliance for automatically interrupting the transmission of energy through any conductor when the current rises above a pre-determined amount.

2.1.56 Damp Situation — A situation in which moisture is either permanently present or intermittently present to such an extent as likely to impair the effectiveness of an installation conforming to the requirements for ordinary situations.

2.1.57 Danger — Danger to health or danger to life or limb from shock, burn or injury from mechanical movement to persons (and livestock where present), or from fire attendant upon the use of electrical energy.

2.1.58 Dead — A portion of an electrical circuit (normally expected to carry a voltage) at or near earth potential or apparently disconnected from any live system. A circuit apparently disconnected from all sources is expected to be at earth potential; but capacitive storage of charge in cables, capacitors, etc, can keep the electric circuit at a significant voltage (and often dangerous voltages from aspects of shock). Such circuits with storage components will be dead only on connection to earth.

2.1.59 Design Current (of a Circuit) — The magnitude of the current intended to be carried by the circuit in normal service.

2.1.60 Direct Contact — Contact of persons or live stock with live parts which may result in electric shock.

2.1.61 Direct Earthing System — A system of earthing in which the parts of an installation are so earthed as specified, but are not connected within the installation

to the neutral conductor of the supply system or to earth through the trip coil of an earth leakage circuit-breaker.

2.1.62 Disconnecter — A mechanical switching device which, in the open position, complies with the requirements specified for the isolation function.

NOTES

1 A disconnecter is otherwise known as isolator.

2 A disconnecter is capable of opening and closing a circuit when either a negligible current is broken or made, or when no significant change in the voltage across the terminals of each pole of the disconnecter occurs. It is also capable of carrying currents under normal circuit conditions and carrying for a specified time, current under abnormal conditions, such as those of short-circuit.

2.1.63 Discrimination (Over-Current Discrimination) — Coordination of the operating characteristics of two or more over-current protective devices should be such that, on the incidence of over-currents within stated limits, the device intended to operate would be the device closest to the point of fault or abnormality, and if proper discrimination is achieved within these limits, only that device closest should operate, while the other circuit breakers upstream do not operate, thereby ensuring that there is minimum area of power supply which is interrupted.

NOTES

1 Protective devices should have discrimination so that only the affected part (minimum section) of the circuit is isolated, even though a number of protective devices may be in the path of the over current.

2 The electrical network requires the discrimination for all the fault circuits, including overload, short-circuit, etc. The downstream device should take care of the fault up to the level of ultimate short-circuit breaking capacity, I_{cu} of the downstream breaker which should be equal to the bus which is connected.

3 Distinction is made between series discrimination involving different over-current protective devices passing substantially the same over-current and network discrimination involving identical protective devices passing different proportions of the over-current.

4 Different types of protective devices may have to be used to ensure effective discrimination in circuits where proper and effective discrimination is necessary. Apart from the built-in sensors and actuators in circuit breakers, external relays operating on different parameters, and comparison of parameters between two or more points will have to be used for complex installations.

5 See also relevant parts of the accepted standard [8-2(5)].

2.1.64 Distance Area or Resistance Area (for an Earth Electrode Only) — The surface area of ground (around an earth electrode) on which a significant voltage gradient may exist.

2.1.65 Diversity Factor — A measure of the probability that a particular piece of equipment will turn on coincidentally to another piece of equipment. For aggregate systems it is defined as the ratio of the sum of the individual non-coincident maximum loads of

various subdivisions of the system to the maximum demand of the complete system.

2.1.66 Duct — A closed passage way formed underground or in a structure and intended to receive one or more cables which may be drawn in.

2.1.67 Ducting — See 2.1.27.

2.1.68 Earth — The conductive mass of the earth, whose electric potential at any point is conventionally taken as zero.

2.1.69 Earth Continuity Conductor — The conductor, including any clamp, connecting to the earthing lead or to each other, those parts of an installation which are required to be earthed. It may be in whole or in part, the metal conduit or the metal sheath or armour of the cables, or the special continuity conductor of a cable or flexible cord incorporating such a conductor.

2.1.70 Earthed Concentric Wiring — A wiring system in which one or more insulated conductors are completely surrounded throughout their length by a conductor, for example a sheath, which acts as a PEN conductor.

2.1.71 Earth Electrode — A conductor or group of conductors in intimate contact with the ground to provide a low resistance path for flow of current to earth.

2.1.72 Earth Electrode Network — Part of an earthing arrangement comprising only the earth electrodes and their interconnections.

2.1.73 Earth Electrode Resistance — The resistance of an earth electrode to earth.

2.1.74 Earth Fault — An unintended and undesirable connection of phase/neutral conductor to earth. When the impedance is negligible, the connection is called a dead earth fault.

2.1.75 Earth Fault Current — A current resulting from a fault of negligible impedance between a line conductor and an exposed conductive part or a protective conductor.

2.1.76 Earthing — Connection of the exposed conductive parts of an installation to the main earthing terminal of that installation.

2.1.77 Earthing Conductor — A protective conductor connecting the main earth terminal (or equipotential bonding conductor of an installation when there is no earth bus) to an earth electrode or to other means of earthing.

2.1.78 Earthing Lead — The final conductor by which the connection to the earth electrode is made.

2.1.79 Earth Leakage Current — A current which flows to earth, or to extraneous conductive parts, in a circuit which is electrically sound.

NOTE — This current may have a capacitive component including that resulting from the deliberate use of capacitors.

2.1.80 Earthing Resistance, Total — The resistance between the main earthing terminal and the earth.

2.1.81 Electrical Equipment (abb: Equipment) — Any item for such purposes as generation, conversion, transmission, distribution or utilization of electrical energy, such as machines, transformers, apparatus, measuring instruments, protective devices, wiring materials, accessories, and appliances.

2.1.82 Electrically Independent Earth Electrodes — Earth electrodes located at such a distance from one another that the maximum current likely to flow through one of them does not significantly affect the potential of the other(s).

2.1.83 Electrical Supply System for Life and Safety Services — A supply system intended to maintain the operation of essential parts of an electrical installation and equipment,

- a) for health and safety of persons and livestock; and
- b) to avoid damage to the environment and to other equipment.

NOTES

1 The supply system includes the source and the circuit(s) up to the terminals of the electrical equipment.

2 See also Part 4 'Fire and Life Safety' of the Code regarding emergency fire and life safety services.

2.1.84 Electric Shock — A dangerous pathophysiological effect resulting from the passing of an electric current through a human body or an animal.

2.1.85 Emergency Switching — Rapid cutting off of electrical energy to remove any hazard to persons, livestock, or property which may occur unexpectedly.

2.1.86 Enclosed Distribution Board — An enclosure containing bus bars with one or more control and protected devices for the purpose of protecting, controlling or connecting more than one outgoing circuits fed from one or more incoming circuits.

2.1.87 Enclosure — A part providing protection of equipment against certain external influences and, in any direction, protection against direct contact.

2.1.88 Equipotential Bonding — Electrical connection putting various exposed conductive parts and extraneous conductive parts at a substantially equal potential.

NOTE — In a building installation equipotential bonding conductors shall interconnect the following conductive parts:

- a) Protective conductor,
- b) Earth continuity conductor, and
- c) Risers of air conditioning system and heating systems (if any).

2.1.89 Exposed Conductive Part — A conductive part of electrical equipment, which can be touched and which is not normally live, but which may become live under fault conditions.

2.1.90 Exposed Metal — All metal parts of an installation which are easily accessible other than,

- a) parts separated from live parts by double insulation;
- b) metal name-plates, screw heads, covers, or plates, which are supported on, or attached, or connected to substantial non-conducting material only in such a manner that they do not become alive in the event of failure of insulation of live parts and whose means of fixing do not come in contact with any internal metal; and
- c) parts which are separated from live parts by other metal parts which are themselves earthed or have double insulation.

2.1.91 External Influence — Any influence external to an electrical installation which affects the design and safe operation of that installation.

2.1.92 Extraneous Conductive Part — A conductive part not forming part of the electrical installation and liable to introduce a potential, generally the earth potential.

2.1.93 Fault — A circuit condition in which current flows through an abnormal or unintended path. This may result from an insulation failure or a bridging of insulation. Conventionally the impedance between live conductors or between live conductors and exposed or extraneous conductive parts at the fault position is considered negligible.

2.1.94 Fault Current — A current resulting from a fault.

2.1.95 Fault Protection — Protection against electric shock under single fault conditions.

NOTE — For low voltage installation, system's and equipment's fault protection generally corresponds to protection against indirect contact, mainly with regards to failure of basic insulation. Indirect contact is 'contact of persons or livestock with exposed-conductive parts which have become live under fault conditions'.

2.1.96 Final Circuit — A circuit connected directly to current using equipment, or to socket outlets or other outlet points for the connection of such equipment.

2.1.97 Fire Survival Distribution Board — A distribution board which continues in service after exposure to fire to the required system rating.

2.1.98 Fitting, Lighting — A device for supporting or containing a lamp or lamps [for example, fluorescent or incandescent or halogen or compact fluorescent lamp (CFL) or light emitting diode (LED)] together with any holder, shade, or reflector, for example, a bracket, a pendant with ceiling rose, an electrolier, or a portable unit.

2.1.99 Fixed Equipment — Equipment fastened to a support or otherwise secured.

2.1.100 Flameproof Enclosure — An enclosure which will withstand without injury any explosion of inflammable gas that may occur within it under practical conditions of operation within the rating of the apparatus (and recognized overloads, if any, associated therewith) and will prevent the transmission of flame which may ignite any inflammable gas that may be present in the surrounding atmosphere.

NOTES

1 Hazardous areas are classified into different zones, depending upon the extent to which an explosive atmosphere may exist at that place. In such areas, flame proof switchgear, fittings, accessories, have to be used/installed in flameproof enclosure.

2 An electrical apparatus is not considered as flameproof unless it complies with the appropriate statutory regulations.

3 Other types of fittings are also in vogue in wiring installations, for example, 'increased safety'.

2.1.101 Functional Earthing — Connection to earth necessary for proper functioning of electrical equipment.

2.1.102 Fuse — A device which, by melting of one or more of its specially designed and proportioned components, opens the circuit in which it is inserted by breaking the current when this exceeds a given value for a sufficient time. The fuse comprises all the parts that form the complete device.

2.1.103 Fuse Carrier — The movable part of a fuse designed to carry a fuse link.

2.1.104 Fuse Element — A part of a fuse designed to melt when the fuse operates.

2.1.105 Fuse Link — A part of fuse, including the fuse element(s), which requires replacement by a new or renewable fuse link after the fuse has operated and before the fuse is put back into service.

2.1.106 Hand-Held Equipment — Portable equipment intended to be held in the hand during normal use, in which the motor, if any, forms an integral part of the equipment.

NOTE — A hand held equipment is an item of equipment, the functioning of which requires constant manual support or guidance.

2.1.107 Harmonics (Current and Voltage) — All alternating current which is not absolutely sinusoidal is made up of a fundamental and a certain number of current and voltage harmonics [multiples of 50 Hz (basic frequency)] which are the cause of its deformation (distortion) when compared to the theoretical sine-wave.

2.1.108 Hazardous Live Part — A live part which can give, under certain condition of external influence, an electric shock.

2.1.109 Impulse Current — A parameter used for the classification test for SPDs; it is defined by three elements, a current peak value, a charge Q and a specific energy W/R.

2.1.110 Impulse Withstand Voltage — The highest peak value of impulse voltage of prescribed form and polarity which does not cause breakdown of insulation under specified condition.

2.1.111 Indirect Contact — Contact of persons or livestock with exposed conductive parts made live by a fault and which may result in electric shock.

2.1.112 Industrial Plugs and Sockets — Plugs and socket-outlets, cable couplers and appliance couplers, primarily intended for industrial use, either indoors or outdoors.

NOTE — For the purpose of this Code, industrial plugs and sockets conforming to IS/IEC 60309-1:2002 'Plugs, socket-outlets and couplers for industrial purposes — Part 1: General requirements'; and IS/IEC 60309-2:2002 'Plugs, socket-outlets and couplers for industrial purposes — Part 2: Dimensional Interchangeability Requirements for Pin and Contact Tube Accessories' shall be used for industrial purpose.

2.1.113 Inflammable Material — A material capable of being easily ignited.

2.1.114 Installation (Electrical) — An assembly of associated electrical equipment to fulfill a specific purpose or purposes and having coordinated characteristics.

2.1.115 Insulated — Insulated shall mean separated from adjacent conducting material or protected from personal contact by a non-conducting substance or an air space, in either case offering permanently sufficient resistance to the passage of current or to disruptive discharges through or over the surface of the substance or space, to obviate danger or shock or injurious leakage of current.

2.1.116 Insulation — Suitable non-conducting material, enclosing, surrounding or supporting a conductor.

2.1.116.1 Insulation, basic — Insulation applied to live parts to provide basic protection against electric shock and which does not necessarily include insulation used exclusively for functional purposes.

2.1.116.2 Insulation, double — Insulation comprising both basic and supplementary insulation.

NOTE — Double insulation for small hand held equipment allows them to be used without a safety earth connection, without shock risk such hand held equipment.

2.1.116.3 Insulation, reinforced — Single insulation applied to live parts, which provides a degree of protection against electric shock equivalent to double insulation under the conditions specified in the relevant standard.

NOTE — The term 'single insulation' does not imply that the insulation is a homogeneous piece. It may comprise several layers which cannot be tested singly as supplementary or basic insulation.

2.1.116.4 Insulation, supplementary — Independent insulation applied in addition to basic insulation in order to provide protection against electric shock in the event of a failure of basic insulation.

2.1.117 Isolation — Cutting off an electrical installation, a circuit, or an item of equipment from every source of electrical energy.

2.1.118 Isolator — A mechanical switching device which, in the open position, complies with the requirements specified for the isolating function. An isolator is otherwise known as a disconnecter.

2.1.119 Junction Box — A box forming a part of wiring installation, intended to conceal electrical connections and joints of conductors/ cables in order to protect the connection from external influences such as direct contact, dust, water, moisture, UV radiation, etc, depending upon the protection requirement of the space or utility.

2.1.120 LEMP Protection Measures (SPM) — Measures taken to protect internal systems against the effects of LEMP.

2.1.121 Lightning Electromagnetic Impulse (LEMP) — All electromagnetic effects of lightning current *via* resistive, inductive and capacitive coupling that create surges and radiated electromagnetic fields.

2.1.122 Lightning Protection — Complete system for protection of structures against lightning, including their internal systems and contents, as well as persons, in general consisting of an LPS and SPM.

2.1.123 Lightning Protection Level (LPL) — A number related to a set of lightning current parameters values relevant to the probability that the associated maximum and minimum design values will not be exceeded in naturally occurring lightning.

NOTE — Lightning protection level is used to design protection measures according to the relevant set of lightning current parameters.

2.1.124 Lightning Protection System (LPS) — Complete system used to reduce physical damage due to lightning flashes to a structure.

2.1.124.1 External lightning protection system — Part of the LPS consisting of an air-termination system, a down-conductor system and an earth-termination system.

2.1.124.2 Internal lightning protection system — Part of the LPS consisting of lightning equipotential bonding and/or electrical insulation of external LPS.

2.1.125 Lightning Protection Zone — Zone where the lightning electromagnetic environment is defined.

2.1.126 Live or Alive — Electrically charged so as to have a potential different from that of earth.

2.1.127 Locations, Industrial — Locations where tools and machinery requiring electrical wiring are installed for manufacture or repair.

2.1.128 Locations, Non-Industrial — Locations other than industrial locations, and shall include residences, offices, shops, showrooms, stores and similar premises requiring electrical wiring for lighting, or similar purposes.

2.1.129 Leakage Current — Electric current in an unwanted conductive path under normal operating conditions.

2.1.130 Line Conductor — A conductor of an a.c. system for the transmission of electrical energy other than a neutral conductor or a PEN conductor. This also means the equivalent conductor of a d.c. system unless otherwise specified in this Code.

2.1.131 Live Part — A conductor or conductive part intended to be energised in normal use including a neutral conductor but, by convention, not a PEN conductor.

2.1.132 Low Voltage Switchgear and Controlgear Assembly — A combination of one or more low voltage switching devices together with associated control, measuring, signalling, protective, regulating equipment, etc, completely assembled under the responsibility of the manufacturer with all the internal electrical and mechanical interconnections and structural parts. The components of the assembly may be electromechanical or electronic.

2.1.133 Luminaire — Equipment which distributes, filters or transforms the light from one or more lamps, and which includes any parts necessary for supporting, fixing and protecting the lamps, but not the lamps themselves, and, where necessary, circuit auxiliaries together with the means for connecting them to the supply.

NOTE — For the purposes of this Code a batten lampholder, or a lampholder suspended by flexible cord, is a luminaire.

2.1.134 Main Earthing Terminal — The terminal or bar which is the equipotential bonding conductor of protective conductors, and conductors for functional earthing, if any, to the means of earthing.

2.1.135 Meshed Bonding Network (MESH-BN) — Bonding network in which all associated equipment frames, racks and cabinets and usually the d.c. power return conductor are bonded together as well as at multiple points to the CBN and may have the form of a mesh.

2.1.136 Mobile Equipment — Electrical equipment which is moved while in operation or which can be easily moved from one place to another while connected to the supply.

2.1.137 Monitoring — Observation of the operation of a system or part of a system to verify correct functioning or detect incorrect functioning by measuring system variables and comparing the measured value with the specified value.

2.1.138 Multiple Earthed Neutral System — A system of earthing in which the parts of an installation specified to be earthed are connected to the general mass of earth and, in addition, are connected within the installation to the neutral conductor of the supply system.

2.1.139 Neutral Conductor — Includes the conductor of a three-phase four-wire system; the conductor of a single-phase or d.c. installation, which is earthed by the supply undertaking (or otherwise at the source of the supply), and the middle wire or common return conductor of a three-wire d.c. or single-phase a.c. system.

2.1.140 Origin of an Electrical Installation — The point at which electrical energy is delivered to an installation.

NOTE — An electrical installation may have more than one origin.

2.1.141 Overcurrent — A current exceeding the rated value. For conductors the rated value is the current carrying capacity.

2.1.142 Overload Current (of a Circuit) — An overcurrent occurring in a circuit in the absence of an electrical fault.

2.1.143 PEN Conductor — A conductor combining the functions of both protective conductor and neutral conductor.

2.1.144 Phase Conductor — See 2.1.130.

2.1.145 Plug — A device, provided with contact pins, which is intended to be attached to a flexible cable,

and which can be engaged with a socket outlet or with a connector.

2.1.146 Point (in Wiring) — A termination of the fixed wiring intended for the connection of current using equipment.

2.1.147 Portable Equipment — Equipment which is moved while in operation or which can easily be moved from one place to another while connected to the supply.

2.1.148 Protection, Ingress — The degree of protection against intrusions (body parts such as hands and fingers), dust, accidental contact and water.

NOTE — The classification of degrees of ingress protection provided by enclosures for electrical equipment shall be as per the accepted standard [8-2(6)].

2.1.149 Protection, Mechanical Impact — The degrees of protection provided by enclosures for electrical equipment against external mechanical impacts.

NOTE — The classification of degrees of protection against mechanical impact provided by enclosures for electrical equipment shall be as per IEC 62262:2002 ‘Degrees of protection provided by enclosures for electrical equipment against external mechanical impacts (IK code)’.

2.1.150 Prospective Fault Current (I_{pt}) — The value of overcurrent at a given point in a circuit resulting from a fault of negligible impedance between live conductor having a difference of potential under normal operating conditions, or between a live conductor and an exposed-conductive part.

2.1.151 Protective Conductor — A conductor used for some measures of protection against electric shock and intended for connecting together any of the following parts:

- a) Exposed conductive parts,
- b) Extraneous conductive parts,
- c) Main earthing terminal, and
- d) Earthed point of the source, or an artificial neutral.

2.1.152 Protective Conductor Current — Electric current appearing in a protective conductor, such as leakage current or electric current resulting from an insulation fault.

2.1.153 Protective Earthing — Earthing of a point or points in a system or in equivalent for the purpose of safety.

2.1.154 Protective Separation — Separation of one electric circuit from another by means of,

- a) double insulation;
- b) basic insulation and electrically protective screening (shielding); or
- c) reinforced insulation.

2.1.155 Rated Current — Value of current used for specification purposes, established for a specified set of operating conditions of a component, device, equipment or system.

2.1.156 Rated Impulse Withstand Voltage Level (U_w) — The level of impulse withstand voltage assigned by the manufacturer to the equipment, or to part of it, characterizing the specified withstand capability of its insulation against overvoltage.

2.1.157 Residual Current — The algebraic sum of the instantaneous values of current flowing through all live conductors of a circuit at a point of the electrical installation.

2.1.158 Residual Current Device (RCD) — A mechanical switching device or association of devices intended to cause the opening of the contacts when the residual current attains a given value under specified conditions.

2.1.159 Residual Operating Current — Residual current which causes the residual current device to operate under specified conditions.

2.1.160 Service — The conductors and equipment required for delivering energy from the electric supply system to the wiring system of the premises served.

2.1.161 Shock Current A current passing through the body of a person or an animal and having characteristics likely to cause dangerous patho-physiological effects.

2.1.162 Short-Circuit Current — An overcurrent resulting from a fault of negligible impedance between live conductors having a difference in potential under normal operating conditions.

2.1.163 Space Factor — The ratio (expressed as a percentage) of the sum of the overall cross-sectional areas of cables (including insulation and sheath) to the internal cross-sectional area of the conduit or other cable enclosure in which they are installed. The effective overall cross-sectional area of a non-circular cable is taken as that of a circle of diameter equal to the major axis of the cable.

2.1.164 Standby Supply System — A system intended to maintain supply to the installation or part thereof, in case of interruption of the normal supply, for reasons other than safety of persons.

NOTE — Standby supplies are necessary, for example, to avoid interruption of continuous industrial processes or data processing.

2.1.165 Stationary Equipment — Either fixed equipment or equipment not provided with a carrying handle and having such a mass that it cannot easily be moved.

2.1.166 Step Voltage — The potential difference between two points on the earth's surface, separated by distance of one pace, that will be assumed to be one metre in the direction of maximum potential gradient.

2.1.167 Socket-Outlet — A device, provided with female contacts, which is intended to be installed with the fixed wiring, and intended to receive a plug.

NOTE — A luminaire track system is not regarded as a socket-outlet system.

2.1.168 Surge — A transient created by LEMP that appears as an overvoltage and/or an overcurrent.

2.1.169 Surge Protective Devices (SPD) — A device intended to limit transient overvoltages and divert surge currents. It contains at least one non-linear component.

2.1.170 Switch — A mechanical switching device capable of making, carrying and breaking current under normal circuit conditions, which may include specified operating overload conditions; and also of carrying for a specified time currents under specified abnormal circuit conditions, such as those of short circuit.

NOTE — A switch may also be capable of making, but not breaking, short-circuit currents.

2.1.171 Switchboard — An assembly of switchgear with or without instruments, but the term does not apply to a group of local switches in a final circuit.

NOTE — The term 'switchboard' includes a distribution board.

2.1.172 Switch Disconnecter — A switch which, in the open position, satisfies the isolating requirements specified for a disconnecter.

NOTE — A switch disconnecter is otherwise known as an isolating switch.

2.1.173 Switch Disconnecter Fuse — A composite unit, comprising a switch with the fuse contained in or mounted on the moving member of the switch.

2.1.174 Switch, Linked — A switch, the contacts of which are so arranged as to make or break all poles simultaneously or in a definite sequence.

2.1.175 Switchgear — An assembly of main and auxiliary switching apparatus for operation, regulation, protection or other control of electrical installations.

2.1.176 System (Electrical) — An electrical system consisting of a single source or multiple sources running in parallel of electrical energy and an installation. Types of system are identified as follows, depending upon the relationship of the source, and of exposed-conductive parts of the installation, to earth:

- a) *TN system* — A system having one or more points of the source of energy directly earthed, the exposed conductive-parts of the installation being connected to that point by

protective conductors.

- b) *TN-C system* — A system in which neutral and protective conductors are combined in a single conductor throughout the system.
- c) *TN-S system* — A system having separate neutral and protective conductor throughout the system.
- d) *TN-C-S system* — A system in which neutral and protective conductors are combined in a single conductor in part of the system.
- e) *TT system* — A system having one point of the source of energy directly earthed, the exposed-conductive-parts of the installation being connected to the earth electrodes electrically independent of the earth electrodes of the source.
- f) *IT system* — A system having no direct connection between live parts and earth, the exposed-conductive-parts of the electrical installation being earthed.

2.1.177 Touch Voltage — The potential difference between the ground potential rise (GPR) of a grounded metallic structure and the surface potential at the point where a person could be standing while at the same time having a hand in contact with the grounded metallic structure. Touch voltage measurements can be 'open circuit' (without the equivalent body resistance included in the measurement circuit) or 'closed circuit' (with the equivalent body resistance included in the measurement circuit) voltage by which an installation or part of an installation is designated.

2.1.178 Usable Wall Space — All portions of a wall, except that occupied by a door in its normal open position, or occupied by a fire place opening, but excluding wall spaces which are less than 1 m in extent measured along the wall at the floor line.

2.1.179 Utility Building — A standalone separate single or two storied service building structure outside the main building structure meant for only accommodating services' spaces, such as electric substation, diesel generator plant room, a.c. plant room, plumbing plant room, sewerage treatment plant, medical gases, electrical and mechanical maintenance rooms. Such buildings do not have any permanent occupancy other than by personnel on duty.

2.1.180 Voltage, Nominal (of an Installation) — Voltage by which an installation or part of an installation is designated.

2.1.181 Voltage, Extra Low (ELV) — The voltage which does not normally exceed 50 V.

2.1.182 Voltage, Low (LV) — The voltage which normally exceeds 50 V but does not normally exceed 250 V.

2.1.183 Voltage, Medium (MV) — The voltage which normally exceeds 250 V but does not exceed 650 V.

2.1.184 Voltage, High (HV) — The voltage which normally exceeds 650 V but less than or equal to 33 kV.

2.1.185 Voltage, Extra High (EHV) — The voltage, which normally exceeds 33 kV.

2.1.186 Weatherproof — Accessories, lighting fittings, current-using appliances and cables are said to be of the weatherproof type with ingress protection according to the application, if they are so constructed that when installed in open situation they will withstand the effects of rain, snow, dust and temperature variations.

2.2 Conventional Symbols

The architectural symbols that are to be used in all drawings, wiring plans, etc, for electrical installations in buildings shall be as given in Annex A.

For other graphical symbols used in electrotechnology, reference may be made to good practice [8-2(1)].

3 GENERAL REQUIREMENTS

3.1 Conformity with *The Electricity Act, 2003 and Central Electricity Authority (Measures Relating to Safety and Electric Supply) Regulations, 2010 as Amended Up-to-Date*

The installation shall generally be carried out in conformity with the requirements of *The Electricity Act, 2003 as amended up-to-date* and the *Central Electricity Authority (Measures Relating to Safety and Electric Supply) Regulations, 2010* framed thereunder and as amended from time-to-time; and also the relevant regulations of the Electric Supply Authority concerned as amended from time-to-time. Extracts from the *Central Electricity Authority (Measures Relating to Safety and Electric Supply) Regulations, 2010* (as amended in 2015), referred to in this Section, are given in Annex B.

3.2 Materials

All materials, fittings, appliances, etc, used in electrical and allied installations, shall conform to Part 5 'Building Materials' of the Code and other concerned Indian Standards.

3.3 Coordination with Local Supply Authority

- a) In all cases, that is, whether the proposed electrical work is a new installation or extension of an existing one, or a modification involving major changes, the electricity supply undertaking shall be consulted about the feasibility, etc, at an early date. The wattage per square metre and permissible diversity consideration shall be defined as per the type

of building (residential, commercial, mercantile, industrial, retail, convention, exhibition, hotel, hospital, institution, flatted factory, group housing, etc). The wattage per square feet shall be defined considering probable loads as per city grading such that future loading into the development is accounted.

- b) *Addition to an Installation* — An addition, temporary or permanent, shall not be made to the authorized load of an existing installation, until it has been definitely ascertained that the current carrying capacity and the condition of existing accessories, conductors, switches, etc, affected, including those of the supply authority are adequate for the increased load. The size of the cable/conductor shall be suitably selected on the basis of the ratings of the protective devices. Ratings of protective devices and their types shall be based on the installed load, switching characteristics and power factor.

Load assessment and application of suitable diversity factor to estimate the full load current shall be made as a first step. This should be done for every circuit, submain and feeder. Power factor, harmonics (see 5.3.6.6) and efficiency of loads shall also be considered. Diversity factor assumed shall be based on one's own experience or as per table under 4.2.2.2. Allowance should be made for about 15 percent to 20 percent for extension in near future. The wiring system should be adopted taking into account the environmental requirements and hazards, if any in the building. The sizes of wiring cables are decided not merely to carry the load currents, but also to withstand thermal effects of likely overcurrents, short circuit and also to ensure acceptance level of voltage drop.

3.4 Power Factor Improvement in Consumers' Installation

3.4.1 Conditions of supply of electricity boards or licensees stipulate the lower limit of power factor which is generally 0.90 or better.

3.4.2 Principal causes of low power factor are many. For guidance to the consumers of electric energy who take supply at low and medium voltages for improvement of power factor, reference shall be made to good practice [8-2(7)].

3.5 Execution of Work

Unless otherwise exempted under the appropriate regulation of the *CEA (Measures relating to Safety and Electricity Supply) Regulations, 2010* as amended from time-to-time, the work of electrical installations shall be carried out by a licensed electrical contractor and

under the direct supervision of a person holding a certificate of competency and by persons holding a valid permit issued and recognized by any State government.

3.6 Safety procedures and practices shall be kept in view during execution of the work in accordance with good practice [8-2(8)].

3.7 Safety provisions given in Part 4 'Fire and Life Safety' of the Code shall be followed.

4 PLANNING OF ELECTRICAL INSTALLATIONS

4.1 General

The design and planning of an electrical wiring installation involve consideration of all prevailing conditions, and is usually influenced by the type and requirements of the consumer. Various utility services including LV systems namely intercom, data cabling (see Part 8 'Building Services, Section 6 Information and Communication Enabled Installations' of the Code), CCTV, fire alarm shall also be taken into account with anticipated future requirements. A competent electrical design engineer should be involved at the planning stage with a view to providing for an installation that will prove adequate for its intended purpose and ensure safety, reliability and energy efficiency in its use. The information/requirements given in 3 shall also be kept into consideration while designing and planning an electrical wiring installation. With the proliferation of the use of electrical and electronic devices in buildings as well as the increase in the generation/distribution capacities of power systems, the hazards of energy feed to a fault or defect in the electrical installation have increased. Reliability of power supply and continued supply even under abnormal conditions are becoming very important not only for the operation of services and activities in a building, but also for the life safety of occupants. Reference is drawn to Part 0 'Integrated Approach — Prerequisite for Applying Provisions of the Code' of the Code, which defines the requirements of interdisciplinary coordination right from the sketch design of the building. Electricity is linked to all services and addition of standby and emergency power supply systems adds to the complexity, thus requiring proper coordinated design. Generally it is not difficult to provide proper pathways and equipment installation spaces, if an integrated approach is taken from the beginning. The designs should also have to keep the availability of optimum access to installations to ensure proper maintenance. Considering various utility services and to avoid conflict amongst them, it is most important to estimate space requirement for electrical work including LV systems, at planning stage and allocate it in consultation with an architect/civil engineer.

4.1.1 The design and planning of an electrical wiring

installation shall take into consideration the following:

- a) Type of supply, building utility, occupancy, envisaged load and the earthing arrangement available;
- b) Provisioning of air conditioning systems in present and/or future loading;
- c) Climatic condition, such as cooling air temperature, moisture or such other conditions which are likely to affect the installation adversely;
- d) Possible presence of inflammable or explosive dust, vapour or gas;
- e) Degree of electrical and mechanical protection necessary;
- f) Importance of continuity of service including the possible need for standby supply;
- g) Probability of need for modification or future extension;
- h) Probable operation and maintenance cost taking into account the electricity supply tariffs available;
- j) Relative cost of various alternative methods;
- k) Need for radio and telecommunication interference suppression;
- m) Ease of maintenance;
- n) Safety aspects;
- p) Energy conservation;
- q) Importance of proper discrimination between protective devices for continuity of supply and limited isolation of only the affected portion; and
- r) Reliability of power supply and redundancy (of sources and distribution paths) to cater to the needs for emergency power and standby power for continued operation of systems as well as integration of alternate sources of energy such as diesel generation, solar energy, wind power, etc.

4.1.2 All electrical apparatus shall be suitable for the services these are intended for.

4.1.3 Coordination

Proper coordination and collaboration between the architect, civil engineer, electrical engineer and mechanical engineer shall be effected from the planning stage of the installation. The electrical engineer shall be conversant with the needs of the electrical supply provider for making electrical supply arrangement. Electrical supplier's installation, as per Regulations, needs to be segregated from consumer's installation. Wherever required, prior approval of drawings shall be taken from concerned electrical supplier/electrical inspector. Further, depending on load and regulation

provisions, consumer will need to submit to the electrical supplier the details regarding the accommodation of substation including transformers, switch-rooms, standby power, solar photovoltaic panels, lightning scheme for the approval. Additional information may be sought by the Authority regarding cable ducts, rising mains and distribution cables, sub-distribution boards, openings and chases in floors and walls for all required electrical installations, etc.

4.1.4 Before starting wiring and installation of fittings and accessories, information should be exchanged between the owner of the building/architect/ consultant/ electrical contractor and the local supply authority in respect of tariffs applicable, types of apparatus that may be connected under each tariff, requirement of space for installing meters, switches, etc, and for total load requirements of lights, fans and power.

4.1.5 While planning an installation, consideration should be taken of the anticipated increase in the use of electricity for lighting, general purpose socket-outlet, kitchen equipment, air conditioning, utility sockets, heating, etc.

It is essential that adequate provision should be made for all the services which may be required immediately and during the intended useful life of the building, for the householder, who may otherwise be tempted to carry out extension of the installation himself or to rely upon use of multi-plug adaptors and long flexible cords, both of which are not recommended.

4.2 Substation and Switchrooms

4.2.1 Location and Other Requirements

The location and other requirements of a substation and switchrooms shall be as given below:

- 1) Availability of power lines nearby may be kept in view while deciding the location of the substation.
- 2) The substation should preferably be located in a separate utility building and may be adjacent to the generator room, if any. Location of substation in the basement should be avoided, as far as possible.
- 3) In case there is only one basement in a building, the substation/switchroom shall not be provided in the basement. Also, the floor level of the substation shall not be lowest point of the basement.
- 4) Ideal location for an electrical substation for a group of buildings will be at the electrical load centre. Generally the load centre will be somewhere between the geometrical centre and the air conditioning plant room, as air conditioning plant room will normally be the largest load, if the building(s) are centrally air

conditioned.

- 5) In order to prevent storm water entering the transformer and switch rooms through the soak-pits, the floor level of the substation/ switchroom shall be at least 300 mm above the highest flood water level that may be anticipated in the locality. Also, facility shall be provided for automatic removal of water.
- 6) Substation shall not be located immediately above or below plumbing water tanks or sewage treatment plant (STP) water tanks at the same location.
- 7) All door openings from substation, electrical rooms, etc, should open outwards. Vertical shutters (like fire rated rolling shutters) may also be acceptable provided they are combined with a single leaf door opening outwards for exit in case of emergency. For large substation room/electrical room having multiple equipment, two or more doors shall be provided which shall be remotely located from each other.
- 8) If substation is located at a height 1 000 m above MSL, then adequate derating of equipment shall be considered.
- 9) In case of HV panel and transformers located at different floors or at a distance more than 20 m, HV isolator shall be provided at transformer end.
- 10) In case transformer and main MV/LV panel room are located at different floors or are at a distance more than 20 m, MV/LV isolator shall be provided at transformer end. In case transformer and main MV/LV panel room are located at different floors, the designer should also take care of the safety requirements caused by lack of direct visibility of the status of the controlling switch. To cater to the safety requirements under different conditions of operation as well as maintenance, it may be necessary to provide additional isolator or an emergency push button in the vicinity to trip the supply. Decision has to be taken based on the possible risks.
- 11) No services or ventilation shafts shall open into substation or switch room unless specific to substation or switch room.
- 12) *Oil-filled installation* — Substations with oil-filled equipment require great consideration for the fire detection, protection and suppression. Oil-filled transformers require a suitable soak pit with gravity flow to contain the oil in the event of the possibility of oil spillage from the transformer on its failure. Installation of oil-filled equipment shall meet the following requirements:

- i) Substations with oil-filled equipment/ apparatus [transformers and high voltage panels] shall be either located in open or in a utility building. They shall not be located in any floor other than the ground floor or the first basement of a utility building. They shall not be located below first basement slab of utility building. They shall have direct access from outside the building for operation and maintenance of the equipment.
- ii) Substations/Utility buildings (where the substation or oil-filled transformer is located) shall be separated from the adjoining buildings including the main building by at least 6 m clear distance to allow passage of fire tender between the substation/utility building and adjoining building/main building.
- iii) There shall be no interconnecting basement with the main building underneath the oil-filled transformers.
- iv) Provisions for oil drainage to a point at a lower level and separated by adequate fire barrier shall be provided. If there is a floor directly below the ground floor level or first basement where the oil-filled transformers and oil-filled circuit breakers are placed, then they shall be separated by a fire barrier of appropriate fire rating as per Part 4 'Fire and Life Safety' of the Code and proper oil drainage system shall be provided to avoid possible leakage of oil into the lower floor.
- v) Substation equipment having more than 2 000 litre of oil whether located indoors in the utility building or outdoors shall have baffle walls of 4 h fire rating between apparatus (*see also* Part 4 'Fire and Life Safety' of the Code for fire safety related requirements).
- vi) Provisions shall be made for suitable oil soak-pit, and where use of more than 9 000 litre of oil in any one oil tank, receptacle or chamber is involved, provision shall be made for the draining away or removal of any oil which may leak or escape from the tank, receptacle or chamber containing the same. Special precautions shall be taken to prevent the spread of any fire resulting from the ignition of the oil from any cause and adequate provision shall be made for extinguishing any fire which may occur.
- vii) In respect of all oil type transformers located at basement, a kerb (sill) of a suitable height shall be provided at the entrance in order to prevent the flow of oil from a ruptured transformer into other parts of the basement in the event of the possibility of oil spillage from the transformer on its failure.
- viii) Adequate fire barriers or deflectors shall be provided to avoid flames from the substation reaching or affecting the upper floors (*see also* Part 4 'Fire and Life Safety' of the Code).
- ix) For transformers having large oil content (more than 2 000 litre), Rule 44(2) of the *Central Electricity Authority (Measures Relating to Safety and Electric Supply) Regulations, 2010* as amended from time-to-time shall apply (*see Annex B*).
- 13) *Dry-type installation* — In case electric substation has to be located within the main multi-storeyed building itself for unavoidable reasons, it shall be a dry-type installation with very little combustible material, such as, a dry type transformer with vacuum (or SF₆) breakers as HT switchgear and ACB or MCCB as medium voltage (MV) switchgear. Such substations shall be located on the ground level or on first basement, and shall have direct access from the outside of the building for operation and maintenance of the equipment.
- Exceptionally, in case of functional buildings, such as air traffic control towers, data centres and buildings of height more than 100 m having high electrical load requirement, dry-type installations/substations may also be provided at upper level. This measure will decrease the current flow and short-circuit rating at various points, thereby reducing vulnerability to fire. In such cases, a base substation shall be located at ground floor/first basement to cater to the main MV/LV panel which feeds life and safety services loads as defined in 4.2.1 (29). The base substation shall be located in such a way to provide direct access to the firemen in case of any emergency. The power supply control to any substation or transformer located at upper floors shall be from the base substation so that in case of fire, the electrical supply can be easily disconnected to avoid additional losses.
- 14) The power supply HV cables voltage shall not be more than 12 kV and a separate dedicated and fire compartmented shaft should be provided for carrying such high voltage cables to upper floors in a building. These shall not be mixed with any other shaft and suitable fire detection and suppression measures shall be provided throughout the length of the cable on

- each floor.
- 15) The provision for installation and removal of substation equipment should be provided from inside or outside the building without disturbing the associated major equipment in the substation.
 - 16) In case of compact substation {see accepted standard [8-2(4)]}, design and location of the substation shall ensure safety of the people around the compact substation installed along walkways, playgrounds, etc. Compact substation with incomer voltage of 12 kV or less, when located in open areas shall have fencing or barrier (of any metal based protection, such as wire mesh or chain link, which is duly earthed) against unauthorized contact possibility around it at a minimum distance of 750 mm around it with access for maintenance from all four sides. For incomer voltage more than 12 kV and less than 24 kV the fencing distance from substation may be 1 000 mm minimum. In case of more than 24 kV incomer, the distance may be further increased accordingly. The fencing design should take care of the servicing and maintenance requirements of the substation equipment.
 - 17) In case of two transformers (dry type or transformers with oil quantity less than 2 000 litre) located next to each other without intermittent wall, the distance between the two shall be minimum 1 500 mm for 11 kV, minimum 2 000 mm for 22 kV and minimum 2 500 mm for 33 kV. Beyond 33 kV, two transformers shall be separated by baffle wall of 4 h fire rating.
 - 18) Horizontal routing of HT cable through functional/occupied areas should be avoided in view of safety.
 - 19) If dry type transformer is used, it may be located adjacent to medium voltage switchgear in the form of unit type substation. In such a case, no separate room or fire barrier for the transformer is required either between transformers or between transformer and the switchgear, thereby decreasing the room space requirement; however, minimum distances as specified in 4.2.1 (17) shall be maintained between the apparatus depending upon voltage ratings. Layout of equipment should take care of the need that any one piece of equipment or sub-assembly can be taken out of service and out of the installed location, while keeping the remaining system in service. Working space for access for maintenance of equipment, while keeping an adjoining section of the substation live to maintain power supply to essential loads, may require additional space between such sections of equipment.
 - 20) In places where flooding can occur and water level may go above 1 000 mm, the base substation may be located on one level above the ground level of a utility building. In such cases, one feeder should feed ground level and levels below with automatic tripping of the feeder to avoid electrocution in case of live electricity coming in contact with water. Designers shall use their discretion in special cases and depending on the degree of reliability, redundancy and the category of load and make suitable provisions.

NOTE — In cases, where the substation is located one level above ground level of utility building, this should be after due evaluation of the other risks posed by such a location combined with the concurrence for such a decision from State Electricity Authority comprising the electrical inspectorate and the distribution licensee and the fire service.
 - 21) For acoustical enclosures/treatment, reference may be made to Part 8 ‘Building Services’, Section 4 ‘Acoustics, Sound Insulation and Noise Control’ of the Code.
 - 22) The minimum recommended spacing between the walls and the transformer periphery from the point of proper ventilation shall be in accordance with good practice [8-2(9)] (see also Fig. 1A). The actual spacing may be different than those given in the figure, depending on the circumstances, such as access to the accessories. Other requirements relating to installation of transformers shall also be in accordance with good practice [8-2(9)].
 - 23) *High voltage switch room/space* — The design should take care of HV equipment space and clearance required around for maintenance and personnel safety as given in 5.3.6.8. This room may preferably have direct access from outside. In case of substation having one transformer and one source of supply, the owner shall provide one high voltage switch. In case of single point supply with two or more transformers, the number of switch required will be one for incoming supply and one for each transformer. Additional space may be provided keeping in mind future requirement, if any. In case of duplicate supply, two switches shall be provided with mechanical/electrical inter locking arrangement. In case the number of incoming and outgoing switches exceed five, bus coupler of suitable capacity should invariably be provided.
 - 24) *Medium voltage switch room/space* — The floor area required in respect of medium voltage switchgear room may be determined keeping in

- view the number and type of incoming/outgoing bus coupler switches including likely expansion in future and space requirement as given in **5.3.6.8**. The additional requirements of MV switchroom when located separate from the substation shall be as per **4.2.4**.
- 25) Other requirements relating to installation of switchgears and controlgears as given in good practice [8-2(10)] shall also be complied with.
 - 26) The minimum height of substation room/HV switch room/MV switch room shall be arrived at considering 1 200 mm clearance requirement from top of the equipment to the below of the soffit of the beam (*see also* Annex C). In case cable entry/exit is from above the equipment (transformer, HV switchgear, MV switchgear), height of substation room/HV switch room/MV switch room shall also take into account requirement of space for turning radius of cable above the equipment height.
 - 27) All the rooms shall be provided with partitions up to the ceiling and shall have proper ventilation. Special care should be taken to dissipate transformer heat and where necessary fresh air louvers at lower level and exhaust fans at higher level shall be provided at suitable locations.
 - 28) In case of cable trench in substation/HV switch room/MV switch room, the same shall be adequately drained to ensure no water is stagnated at any time with live cables.
 - 29) *Power supply to emergency fire and life safety systems* — Emergency power supplying distribution system for critical requirement for functioning of fire and life safety system and equipment, shall be planned for efficient and reliable power and control supply to the following systems and equipment where provided:
 - i) Fire pumps;
 - ii) Pressurization and smoke venting; including its ancillary systems such as dampers and actuators;
 - iii) Fireman's lifts (including all lifts).
 - iv) Exit signage lighting;
 - v) Emergency lighting;
 - vi) Fire alarm system;
 - vii) Public address (PA) system (relating to emergency voice evacuation and annunciation);
 - viii) Magnetic door hold open devices; and
 - ix) Lighting in fire command centre and security room.

Power supply to these systems and equipment shall be from normal and emergency (standby generator) power sources with change over facility. It shall be ensured that in case the power supply is from HT source/HT generation, transformers should be planned in stand-by capacity to ensure continuity of power to such systems. Wherever transformers are installed at higher levels in buildings and backup DG sets are of higher voltage rating, then dual redundant cables shall be taken to all transformers. The generator shall be capable of taking starting current of all the fire and life safety systems and equipment as above. Where parallel HV/LV supply from a separate substation fed from different grid is provided with appropriate transformer for emergency, the provision of generator may be waived in consultation with the Authority.

The power supply to the panel/distribution board of these fire and life safety systems shall be through fire proof enclosures or circuit integrity cables or through alternate route in the adjoining fire compartment to ensure that supply of power is reliable to these systems and equipment. It is to be ensured that the cabling from the adjoining fire compartment is to be protected within the compartment of vulnerability. The location of the panel/distribution board feeding the fire and life safety system shall be in fire safe zone ensuring supply of power to these systems.

Cables for fire alarm and PA system shall be laid in metal conduits or armoured to provide physical segregation from the power cables.

- 30) Other requirements as given in *Central Electricity Authority (Measures relating to Safety and Electricity Supply) Regulations, 2010* as amended shall also be complied with. The fire safety requirements for substation and electrical rooms, including fire rating requirements of substations enclosure, that is, walls, floor, ceiling, openings, doors, etc, as given in Part 4 'Fire and Life Safety' of the Code shall also be complied with.

4.2.2 Layout of Substation

4.2.2.1 In allocating the area of substation, it is to be noted that the flow of electric power is from supply company's meter room to HV room, then to transformer and finally to the MV switchgear room. The layout of the room and trenches of required depth shall be in accordance with this flow, so as to optimize the cables, bus-trunking, etc. Visibility of equipment controlled from the operating point of the controlling switchgear is also a desirable feature, though it may not be achievable in case of large substations. Substations shall not be located

at or across expansion joints. The rooms/spaces required in a substation shall be provided as given below:

- a) *Supply company's meter room*, generally at the periphery of the premise with direct access from the road/outside;
- b) *HV isolation room*, required in case the substation is away from the meter room and is planned adjacent to meter room for disconnecting supply in case of any repair required between meter room and substation;
- c) *HV panel room/space*, located adjacent to transformer;
- d) *Transformer room/space*, separate space in case of oil-filled transformer and combined space in case of dry type transformer;
- e) *MV isolation room/space*, required in case MV

panel is away from transformer or on a different level for isolating supply in case of any repair required between transformer and MV switchgear; and

- f) *Main MV panel room/space*, required for distribution to different facility/utility in a building.

A typical layout of a substation is shown in Fig. 1B.

4.2.2.2 Capacity and size of substation

The capacity of a substation depends upon the area of the building and its type. The capacity of substation may be determined based on the load requirements (*see also 3.3*). Ratings of electrical equipment as given in 6.1, may be assumed, unless the values are known or specified and diversity requirements as given below may be used for load assessment:

Sl No.	Purpose of Final Circuit Fed from Conductors or Switchgear to which Diversity Applies	Typical Allowances for Diversity Based on: Type of Building		
		Individual House Hold Installations, Including Individual Dwelling of a Block	Small Shops, Stores, Offices and Business Premises	Small Hotels, Boarding Houses, etc
(1)	(2)	(3)	(4)	(5)
i)	Lighting	66 percent of total current demand	90 percent of total current demand	75 percent of total current demand
ii)	Heating and power [<i>see also</i> Sl No. (iii) to (iv)]	100 percent of total current demand up to 10 A + 50 percent of any current demand in excess of 10 A	100 percent of full load of largest appliance + 75 percent of remaining appliances	100 percent of full load of largest appliance + 80 percent of second largest appliance + 60 percent of remaining appliances
iii)	Cooking appliances	10 A + 30 percent full load of connected cooking appliances in excess of 10 A + 6 A if socket-outlet incorporated in the unit	100 percent of full load of largest appliance + 80 percent of full load of second largest appliance + 60 percent of full load of remaining appliances	100 percent of full load of largest appliance + 80 percent of full load of second largest appliance + 60 percent of full load of remaining appliances
iv)	Motors (other than lift motors which are subject to special consideration)		100 percent of full load of largest motor + 80 percent of full load of second largest motor	100 percent of full load of largest motor + 50 percent of full load of remaining motors

Sl No.	Purpose of Final Circuit Fed from Conductors or Switchgear to which Diversity Applies	Typical Allowances for Diversity Based on: Type of Building		
		Individual House Hold Installations, Including Individual Dwelling of a Block	Small Shops, Stores, Offices and Business Premises	Small Hotels, Boarding Houses, etc
(1)	(2)	(3)	(4)	(5)
			+ 60 percent of full load of remaining motors	
v)	Water heater [instantaneous type ¹⁾]	100 percent of full load of largest appliance + 100 percent of full load of second largest appliance + 25 percent of full load of remaining appliances	100 percent of full load of largest appliance + 100 percent of full load of second largest appliance + 25 percent of full load of remaining appliances	100 percent of full load of largest appliance + 100 percent of full load of second largest appliance + 25 percent of full load of remaining appliances
vi)	Water heater (thermostatically controlled)	No diversity allowable ²⁾		
vii)	Floor warming installations	No diversity allowable ²⁾		
viii)	Water heaters thermal storage space heating installations	No diversity allowable ²⁾		
ix)	Standard arrangements of final circuits in accordance with good practice [8-2(11)]	100 percent of the current demand of the largest circuit + 40 percent of the current demand of every other circuit	100 percent of the current demand of the largest circuit + 50 percent of the current demand of every other circuit	
x)	Socket outlets other than those included in Sl No. (ix) and stationary equipment other than those listed above	100 percent of the current demand of the largest point + 40 percent of the current demand of every other point	100 percent of the current demand of the largest point + 75 percent of the current demand of every other point	100 percent of the current demand of the largest point + 75 percent of the current demand of every point in main rooms (dining rooms, etc) + 40 percent of the current demand of every other point

NOTE — Diversity may be considered , if multiple units of water heater are there in an individual house -hold installation, including individual dwelling of a block

¹⁾ For the purpose of the table, an instantaneous water heater is deemed to be a water heater of any loading which heats water only while the tap is turned on and therefore uses electricity intermittently.

²⁾ It is important to ensure that the distribution boards are of sufficient rating to take the total load connected to them without the application of any diversity.

SUPPLIED BY BOOK SUPPLY BUREAU UNDER THE LICENSE FROM BIS FOR MANIPAL INSTITUTE OF TECHNOLOGY - MANIPAL ON 11/06/2024 15:54:42 (45.112.148.130) VALID UPTO31/12/2024

After calculating the electrical load on the above basis, an overall load factor of 70 to 90 percent is to be applied to arrive at the minimum capacity of substation. A future load may also be considered for substation sizing (see 3.3). The area required for substation and transformer room for different capacities is given in Annex C for general guidance. For reliability, it is recommended to split the load into more than one transformer and also provide for standby transformer as well as multiple sources, bus-section, etc.

4.3 Emergency Power Backup System

4.3.1 Location

The emergency power supply (such as generating sets) should not be allowed to be installed above ground floor or below the first basement level of the building. In case of DG set located in basement, the ceiling of the DG room shall be the ground floor slab. It is preferable

to install the standby generator in utility building. If installed in the enclosed space, facilities for forced ventilation shall be provided such that there is minimum derating of the equipment. The generating set should preferably be housed adjacent to MV switchgear in the substation building to enable transfer of electrical load efficiently and also to avoid transfer of vibration and noise to the main building.

4.3.2 Room for Emergency Power Backup System

The capacity of standby generating set shall be sized for emergency fire and life safety systems [see 4.2.1 (29)] and other utilities as required and identified for functional requirement of the building. Having chosen the capacity and number of generating sets, required space may be provided for their installation (see Annex D for general guidance). There shall be provision of separate direct escape and entry from outside so that in case of fire, electrical supplies can be disconnected to

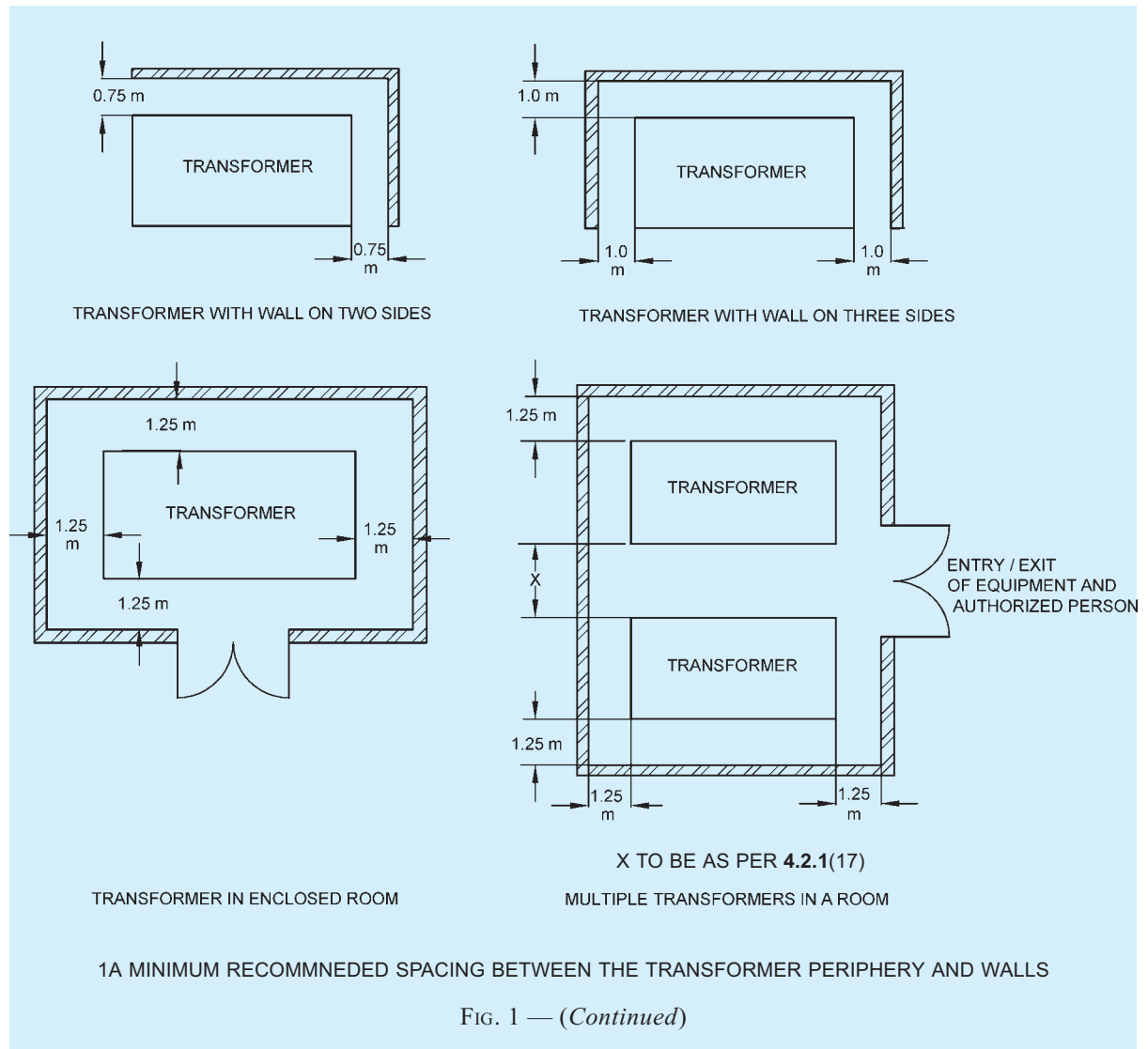

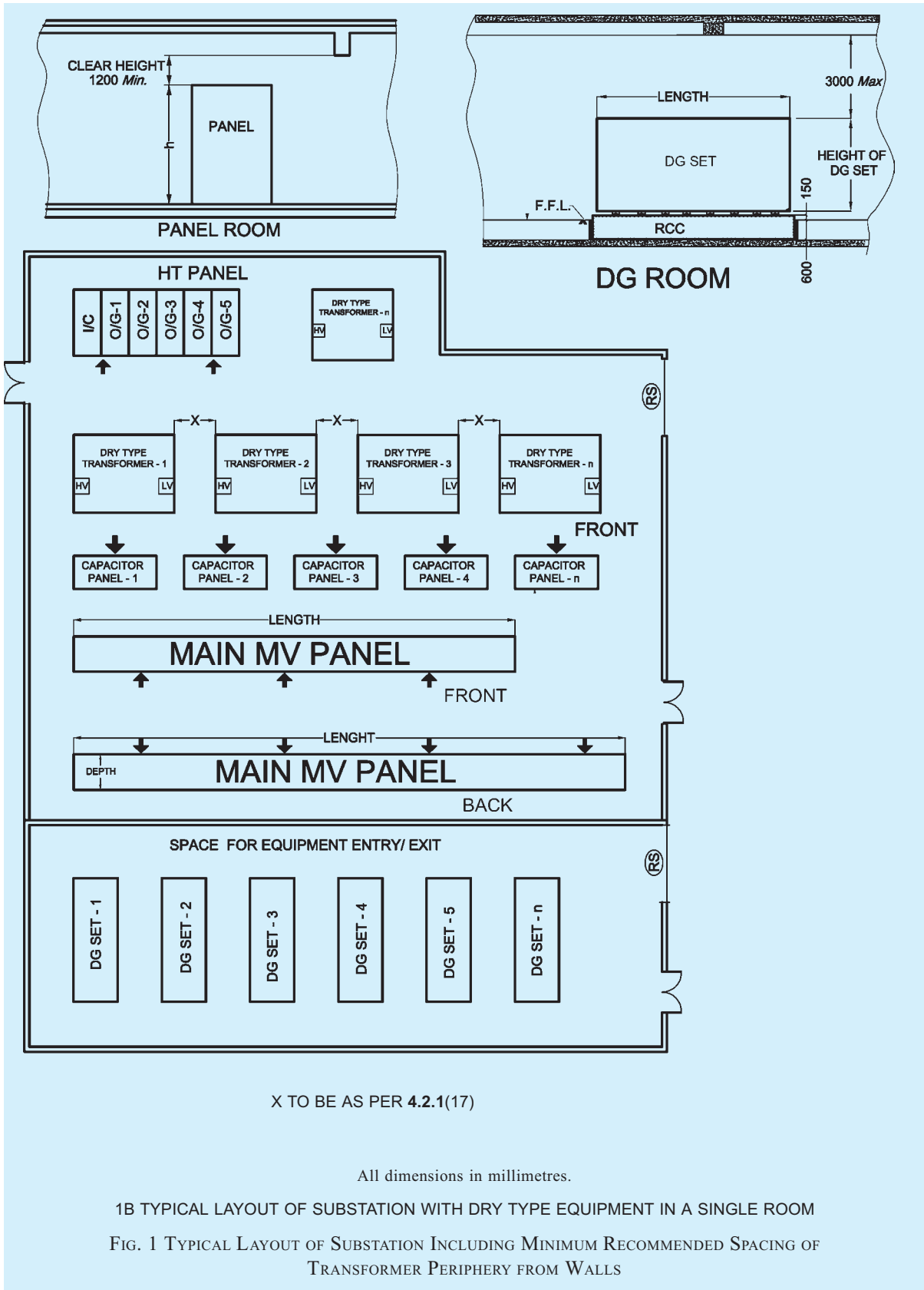

avoid additional losses which may be caused due to electrical supply, present at the time of fire. The height of diesel generating (DG) set rooms shall however be not more than 3 000 mm above the DG set height, unless required due to DG room ventilation requirements. Adequate space shall be provided for storing of fuel. Facilities including space at appropriate positions, relative to the location of the installed equipment has to be kept in the layout design for removal of equipment or sub-assemblies for repair or maintenance. When it is located at a place, other than the ground level with direct equipment access, a hatch or ramp shall be provided.

4.3.3 Installation and Other Requirements

Following installation and other requirements shall also be complied with:

- a) Day-oil tanks for the DG sets shall be in compliance with *The Petroleum Act, 1934*.
- b) The emergency installation shall comply with the norms laid down by the Central Pollution Control Board (CPCB) and shall also be in compliance with *The Petroleum Act, 1934* and guidelines of Oil Industry Safety Directorate (OISD). Compartmentation for fire protection with detection and first-aid protection measures is essential.
 NOTE — Different type of fire safety requirements exists for the diesel engine and generator for the oil storage area and for the switchgear (*see also* Part 4 'Fire and Life Safety' of the Code).
- c) Acoustic enclosure for DG sets/acoustic lining of the DG room and ventilation system for DG room shall be in line with the requirements of CPCB. If DG set is located outdoors, it shall be housed in acoustics enclosure as per the requirements of CPCB norms. For acoustical enclosures/treatment, reference shall also be made to Part 8 'Building Services, Section 4 Acoustics, Sound Insulation and Noise Control' of the Code.
- d) The generator house should have proper ventilation for engine combustion requirements and as well as for the body heat removal apart from the heat removal from radiator or cooling tower, fire fighting equipment, etc. The other requirements given in Part 4 'Fire and Life Safety' of the Code for room for emergency power backup system including DG set room shall also be complied with.
- e) Other environmental requirements under the provisions of *Environment Protection Rules, 1986* and norms laid down by CPCB, as amended from time-to-time shall be taken into

account particularly from the aspect of engine emissions including the height of exhaust pipe and permitted noise levels/controls.

4.4 Location of MV/LV Switch Room Other than in Substation

In large installations other than where a substation is provided, a separate switch room shall be provided; this shall be located as close to the electrical load centre as possible, on the ground floor or on the first basement level of the building. Suitable cable trays shall be laid with minimum number of bends from the points of entry of the main supply cable to the position of the main switchgear. The switch room shall also be placed in such a position that riser shafts may readily be provided therefrom to the upper floors of the building in one straight vertical run. In larger buildings, more than one riser shaft may be required and then horizontal trays may also be required for running cables from the switch room to the foot of each rising main. Such cable trays shall either be reserved for specific voltage grades or provided with a means of segregation for medium, low and extra low voltage installations, such as call-bell systems, telephone installations, fire detection and alarm system, security systems, data cables and announcement or public address system. Cables/wires for emergency fire and life safety services and their routing shall be in accordance with 4.2.1 (29) and Part 4 'Fire and Life Safety' of the Code so that these services are maintained even in the event of a fire.

4.5 Location and Requirements of Distribution Panels

All distribution panels, switchgears shall be installed in readily accessible position. The electrical control gear distribution panels and other apparatus, which are required on each floor may conveniently be mounted adjacent to the rising mains, and adequate space considering clearances required as per 5.3.6.8 shall be provided at each floor for this purpose.

4.6 Substation Safety

The owner and the operator of any substation shall be collectively and severally be responsible for any lapse or neglect leading to an accident or an incidence of an avoidable abnormality and shall take care of the following safety requirements:

- a) Enclose the substation or similar equipment where necessary to prevent, so far as is reasonably practicable, danger of electric shock or unauthorized access;
- b) Enclose any part of the substation which is open to the air, with a fence (earthed efficiently at both ends) or wall not less than 1 800 mm (preferably not less than 2 400 mm) in height;

- to prevent, so far as is reasonably practicable, danger of electric shock or unauthorized access;
- c) Ensure that there are at all times displayed,
 - 1) sufficient safety signs of such size and placed in such positions as are necessary to give due warning of such danger as is reasonably foreseeable in the circumstances;
 - 2) a notice which is placed in a conspicuous position and which gives the location or identification of the substation, the name of each generator or distributor who owns or operates the substation equipment making up the substation and the telephone number where a suitably qualified person appointed for this purpose by the generator or distributor will be in constant attendance; and
 - 3) such other signs, which are of such size and placed in such positions, as are necessary to give due warning of danger having regard to the siting of, the nature of, and the measures taken to ensure the physical security of, the substation equipment;
 - d) Take all reasonable precautions to minimize the risk of fire associated with the equipment; and
 - e) Ensure that, in addition to provisions mentioned in (c), name and emergency telephone number of the authorized personnel shall also be displayed at the substation and instructions covering schematic diagram; requirements of switchgear interlocking, if any; and permission requirements, if any, for load limitations on (incoming) feeders; be also prominently displayed.

4.7 Overhead Lines, Wires and Cables

All erections/alterations having relation to overhead lines, wires and cables shall comply with Central Electricity Authority regulations and the following. However, in case of any conflict, the regulations shall prevail.

4.7.1 Height Requirement

4.7.1.1 While overhead lines may not be relevant within buildings, regulations related to overhead lines are of concern from different angles as follows:

- a) Overhead lines may be required in building complexes, though use of underground cables is the preferred alternative.
- b) Overhead lines may be passing through the

site of a building. In such a case the safety aspects are important for the construction activity in the vicinity of the overhead line as well as portions of low height buildings that may have to be constructed below the overhead lines. Overhead lines running adjacent to buildings pose hazard from the aspect of certain maintenance activity (such as use of a ladder on external face of a building) causing temporary compromise of the minimum safety clearance.

4.7.1.2 If at any time subsequent to the erection of an overhead line, whether covered with insulating material or not, or underground cable, any person who proposes to erect a new building or structure or to raise any road level or to carry out any other type of work whether permanent or temporary or to make in or upon any building, or structure or road, any permanent or temporary addition or alteration, in proximity to an overhead line or underground cable, such person and the contractor whom he employs to carry out the erection, addition or alteration, shall give intimation in writing of his intention to do so, to the supplier or owner and to the Electrical Inspector and shall furnish therewith a scale drawing showing the proposed building, structure, road or any addition or alteration and scaffolding thereof required during the construction. In this connection, Regulation 63 of *Central Electricity Authority (Measures Relating to Safety and Electricity Supply) Regulations, 2010*, as amended from time-to-time shall also be complied with (*see Annex B*).

4.7.1.3 Any person responsible for erecting an overhead line will keep informed the authority(s) responsible for services in that area for telecommunication, gas distribution, water and sewage network, roads so as to have proper coordination to ensure safety. He shall also publish the testing, energizing programme for the line in the interest of safety.

4.7.1.4 For minimum distance (vertical and horizontal) of electric lines/wires/cables from buildings, reference may be made to Part 3 'Development Control Rules and General Building Requirements' of the Code. In this connection, Regulations 58, 60, 61, and 65 of *Central Electricity Authority (Measures Relating to Safety and Electricity Supply) Regulations, 2010*, as amended from time-to-time shall also be complied with (*see Annex B*).

4.7.1.5 Regulation 64 of *Central Electricity Authority (Measures Relating to Safety and Electricity Supply) Regulations, 2010*, as amended from time-to-time, which govern conditions related to the storage of material including storage of construction material at a construction site, or other materials in a building in

vicinity of overhead lines and underground cables, shall also be complied with (*see Annex B*).

4.7.2 Position, Insulation and Protection of Overhead Lines

4.7.2.1 Any part of an overhead line which is not connected with earth and which is not ordinarily accessible shall be supported on insulators or surrounded by insulation. Any part of an overhead line which is not connected with earth and which is ordinarily accessible shall be,

- a) made dead; or
- b) so insulated that it is protected, so far it is reasonably practicable, against mechanical damage or interference; or
- c) adequately protected to prevent danger.

4.7.2.2 Any person responsible for erecting a building or structure which will cause any part of an overhead line which is not connected with earth to become ordinarily accessible shall give reasonable notice to the licensee or distributor who owns or operates the overhead line of his intention to erect that building or structure.

The expression 'ordinarily accessible' means the overhead line might be reachable by hand if any scaffolding, ladder or other construction was erected or placed on/in, against or near to a building or structure.

4.7.2.3 Any bare conductor not connected with earth, which is part of a low voltage overhead line, shall be situated throughout its length directly above a bare conductor which is connected with earth.

4.7.3 Precautions against Access and Warnings of Dangers

4.7.3.1 Every support carrying a high voltage overhead line shall be fitted with anti-climbing devices to prevent any unauthorized person from reaching a position at which any such line will be a source of danger. In this connection, Regulation 73(3) of *Central Electricity Authority (Measures Relating to Safety and Electricity Supply) Regulations, 2010*, as amended from time-to-time shall also be complied with (*see Annex B*).

4.7.3.2 Every support carrying a high voltage overhead line, and every support carrying a low voltage overhead line incorporating bare phase conductors, shall have attached to it sufficient safety signs and placed in such positions as are necessary to give due warning of such danger as is reasonably foreseeable in the circumstances.

4.7.3.3 Poles supporting overhead lines near the road junctions and turnings shall be protected by a masonry

or earth fill structure or metal barricade, to prevent a vehicle from directly hitting the pole, so that the vehicle, if out of control, is restrained from causing total damage to the live conductor system, likely to lead to a hazardous condition on the road or footpath or building.

4.7.4 Fitting of Insulators to Stay Wires

Every stay wire which forms part of, or is attached to, any support carrying an overhead line incorporating bare phase conductors (except where the support is a lattice steel structure or other structure entirely of metal and connected to earth) shall be fitted with an insulator, no part of which shall be less than 3 m above ground or above the normal height of any such line attached to that support.

4.8 Maps of Underground Networks

4.8.1 Any person or organization or authority laying cables shall contact the local authority in charge of that area and find out the layout of,

- a) water distribution pipe lines in the area;
- b) sewage distribution network;
- c) telecommunication network,
- d) gas pipeline network; and
- e) existing power cable network,

and plan the cable network in such a manner that the system is compatible, safe and non-interfering either during its installation or during its operation and maintenance. Plan of the proposed cable installation shall be brought to the notice of the other authorities referred above.

4.8.2 Suitable cable markers and danger sign as will be appropriate for the safety of the workmen of any of the systems shall be installed along with the cable installation. Cable route markers shall be provided at every 20 m and also at turnings and/or crossings.

4.8.3 Notification of testing and energization of the system shall also be suitably publicized for ensuring safety.

4.8.4 Any person or organization or authority associated with the operation and maintenance of services in a complex is required to have a complete integrated diagram or drawings of all services with particular emphasis on the hidden pipes, cables, etc, duly kept up-to-date by frequent interaction with all agencies associated with the maintenance work.

Organization or agency responsible for laying cables shall have and, so far it is reasonably practicable, keep up-to-date, a map or series of maps indicating the position and depth below surface level of all networks or parts thereof which he owns or operates. Where adequate mapping has not been done and the excavation

for cable laying reveals lines pertaining to any of the other services, record of three dimensional location should be marked and recorded. Even where mapping exists, it may be examined if the records have become obsolete due to change such as, in road level. Any map prepared or kept shall be available for inspection by any authority, such as municipality, water supply, sewage, service providers, general public provided they have a reasonable cause for requiring reference to any part of the map.

4.8.5 Any agency working on any one or more service (occupying the underground space for service pipes, cables, etc) should keep the other agencies informed of the work so that an inadvertent action will not cause a disruption of service. Each agency should be responsible for keeping the latest information with the central authority of such records and should be responsible to ensure that the modifications, if any are duly updated and notified among the other agencies.

5 DISTRIBUTION OF SUPPLY AND CABLING

5.1 General

5.1.1 In the planning and design of an electrical wiring installation, due consideration shall be made of all the prevailing conditions. It is recommended that advice of a competent electrical engineer be sought at the initial stage itself with a view to providing an installation that will prove adequate for its intended purpose, be reliable, safe and efficient.

5.1.2 A certain redundancy in the electrical system is necessary and has to be built in from the initial design stage itself. The extent of redundancy will depend on the type of load, its criticality, normal hours of use, quality of power supply in that area, coordination with the standby power supply, capacity to meet the starting current requirements of large motors, etc.

5.1.3 In modern building technology, following high demands are made of the power distribution system and its individual components:

- a) Long life and good service quality;
- b) Safe protection in the event of fire;
- c) Low fire load;
- d) Flexibility in load location and connection, but critical in design;
- e) Low space requirement; and
- f) Minimum effort involved in carrying out retrofits.

5.1.4 The high load density in modern large buildings and high rise buildings demands compact and safe solution for the supply of power. The use of busbar trunking system is ideal for such applications. Busbar trunking can be installed in vertical risers shafts or

horizontally in passages for transmission and distribution of power. They allow electrical installations to be planned in a simple and neat manner. In the building complexes, additional safety demands with respect to fire barriers and fire load can also be met with the use of busbar trunking. Busbar trunking system also reduces the combustible material near the area with high energy in comparison with other distribution systems such as cables and makes the building safe from the aspect of vulnerability to fire of electrical origin. In addition, unlike cable systems the reliability of a busbar trunking system is very high. These systems also require very little periodic maintenance. Choice of busbar trunking for distribution in buildings can be made on the basis of,

- a) reduced fire load (drastically reduced in comparison to the cable system);

NOTE — Insulation materials of cables are required to be fire resistant and an essential performance requirement is that the insulation material may burn or melt and flow when directly exposed to a temperature (or fire) higher than what it is class designated for, but should not continue to burn after the flame or the source of heat or fire is withdrawn. Even if the above fire resistant property is exhibited by the cable insulation, a large collection of cables will make the cable insulation fail to exhibit this retardant property. While specific guidelines for limiting number of cable and bunching is not available and in such cases the switch over to a bus trunking system is the proper alternative.

- b) reduced maintenance over its entire lifetime;
- c) longer service lifetime in comparison with a cable distribution; and
- d) enhanced reliability due to rigid bolted joints and terminations and extremely low possibility of insulation failure.

5.2 System of Supply

5.2.1 All electrical apparatus shall be suitable for the voltage and frequency of supply.

5.2.2 In case of connected load of 100 kVA and above, the relative advantage of high voltage three-phase supply should be considered. Though the use of high voltage supply entails the provisions of space and the capital cost of providing suitable transformer substation at the consumer's premises, the following advantages are gained:

- a) advantage in tariff;
- b) more effective earth fault protection for heavy current circuits;
- c) elimination of interference with supplies to other consumers permitting the use of large size motors, welding plant, etc; and
- d) better control of voltage regulation and more constant supply voltage.

NOTE — Additional safety precautions required to be observed in HV installations shall also be kept in view.

In many cases there may be no choice available to the consumer, as most of the licensees have formulated their policy of correlating the supply voltage with the connected load or the contract demand. Generally the supply is at 240 V single phase up to 5 kVA, 415/240 V 3-phase from 5 kVA to 100 kVA, 11 kV (or 22 kV) for loads up to 5 MVA and 33 kV or 66 kV for consumers of connected load or contract demand more than 5 MVA.

5.2.3 In very large industrial buildings where heavy electric demands occur at scattered locations, the economics of electrical distribution at high voltage from the main substation to other subsidiary transformer substations or to certain items of plant, such as large motors and furnaces, should be considered. The relative economy attainable by use of medium or high voltage distribution and high voltage plant is a matter of expert judgment and individual assessment in light of experience by a professionally qualified electrical engineer.

5.3 Substation Equipment and Accessories

Substations require an approval by the Electrical Inspectorate. Such approval is mandatory before energizing the substation. It is desirable to get the approval for the general layout, schematic layout, protection plan, etc, before the start of the work from the Inspectorate. All substation equipment and accessories and materials, etc, shall conform to relevant Indian Standards, wherever they exist, otherwise the consumer (or his consultant) shall specify the standards to which the equipment to be supplied conforms and that shall be approved by the authority. Manufacturers of equipment have to furnish certificate of conformity as well as type test certificates for record, in addition to specified test certificates for acceptance tests and installation related tests for earthing, earth continuity, load tests and tests for performance of protective gear.

5.3.1 *Supply Company's High Voltage Meter Board*

In case of single point high voltage metering, energy meters shall be installed in building premise as per **4.2.2.1**, at such a place which is readily accessible to the owner/operator of the building and the Authority. The supplier or owner of the installation shall provide at the point of commencement of supply a suitable isolating device fixed in a conspicuous position at not more than 1.7 m above the ground so as to completely isolate the supply to the building in case of emergency. In this connection, *Central Electricity Authority (Installation and Operation of Meters) Regulations, 2006*, as amended from time-to-time shall be complied with.

5.3.2 High Voltage Switchgear

5.3.2.1 The selection of the type of high voltage switchgear for any installation *inter alia* depends upon the following:

- a) Voltage of the supply system;
- b) Prospective short-circuit current at the point of supply;
- c) Size and layout of electrical installation;
- d) Accommodation available; and
- e) Nature of industry.

Making and breaking capacity of switchgear shall be commensurate with short-circuit potentialities of the supply system and the supply authority shall be consulted on this subject. HV switchgear and controlgear shall conform to the accepted standards [8-2(14)] and other relevant Indian Standards.

5.3.2.2 Guidelines on various types of switchgear equipment and their choice for a particular application shall be in accordance with good practice [8-2(12)].

5.3.2.3 In extensive installations of switchgear (having more than four incoming supply cables or having more than 12 circuit breakers), banks of switchgears shall be segregated from each other in order to prevent spreading of the risk of damage by fire or explosion arising from switch failure. Where a busbar section switch is installed, it shall also be segregated from adjoining banks in the same way {see good practice [8-2(13)]}.

5.3.2.4 It should be possible to isolate any section from the rest of the switchboards such that work might be undertaken on this section without the necessity of making the switchboard dead. Isolating switches used for the interconnection of sections or for the purpose of isolating circuit-breakers of other apparatus, shall also be segregated within its compartment so that no live part is accessible when work in a neighbouring section is in progress.

5.3.2.5 In the case of double or ring main supply, switchgears with interlocking arrangement shall be provided to prevent simultaneous switching of two different supply sources. Electrical and/or mechanical interlocks may preferably be provided.

5.3.3 HV Cables

5.3.3.1 The sizing of the cable shall depend upon the method of laying cable, current to be carried, permissible maximum temperature it shall withstand, voltage drop over the length of the cable, the prospective short-circuit current to which the cable may be subjected, the characteristics of the overload protection gear installed, load cycle, thermal resistivity of the soil and the operating voltage {see also good practice [8-2(15)]}.

5.3.3.2 All HV cables shall be installed in accordance with good practice [8-2(15)]. The HV cables shall either be laid on the cable rack/built-up concrete trenches/tunnel/basement or directly buried in the ground depending upon the specific requirement. When HV cable is hanging/running below the basement ceiling slab, the cable shall be laid in a fire rated enclosure/cable tray. The advice of the cable manufacturer with regard to installation, jointing and sealing should also be followed.

5.3.4 High Voltage Bus Bar Trunking/Ducting

HV bus bar system is used for transporting power between HV generators, transformers and the infeed main switchgear of the main HV switchgear.

Generally three types of bus ducts, namely non-segregated, segregated and isolated phase bus duct are used. The non-segregated bus ducts consist of three phase bus bars running in a common enclosure made of steel or aluminium. The enclosure shall provide safety for the operational personnel and shall reduce chances of faults. HV interconnecting bus bar trunking for a.c. voltage above 1 kV up to and including 36 kV shall conform to accepted standard [8-2(16)]. The enclosures shall be effectively grounded.

Segregated phase bus ducts are similar to non-segregated phase ducts except that metal or isolation barriers are provided between phase conductors to reduce chances of phase to phase faults. However, it is preferable to use metal barriers.

In the case of isolated bus ducts, each phase conductor shall be housed in a separate non-magnetic enclosure. The bus duct shall be made of sections which are assembled together at site to make complete assembly. The enclosure shall be of either round or square shape and welded construction. The enclosures of all phases in general should be supported on a common steel structure.

Seismic supports shall be provided for busbar trunking having continuous straight lengths of more than 24 m at a single stretch.

The bus duct system shall be coordinated with connecting switchgear so as to provide adequate protection.

When busbar trunking is crossing different fire compartments, they shall have fire barriers of same rating as that of the compartment (*see also* Part 4 'Fire and Life Safety' of the Code).

5.3.5 Transformers

5.3.5.1 General design objective while selecting the transformer(s) for a substation should be to provide at least two or more transformers, so that a certain amount

of redundancy is built in, even if a standby system is provided. The total installed transformer capacity shall be at least 15 to 20 percent higher than the anticipated maximum demand. With growing emphasis on energy conservation, the system design is made for both extremes of loading. During the periods of lowest load in the system, it would be desirable to operate only one transformer and to subsequently switch on the additional transformers as the load increases during the day. Total transformer capacity is generally selected on the basis of present load, possible future load, operation and maintenance cost and other system conditions. The selection of the maximum size (capacity) of the transformer is guided by the short-circuit making and breaking capacity of the switchgear used in the medium voltage distribution system. Maximum size limitation is important from the aspect of feed to a downstream fault. The transformers shall conform to accepted standards [8-2(17)] and other relevant Indian Standards.

5.3.5.2 For reasons of reliability and redundancy it is normal practice to provide at least two transformers for any important installation. Interlinking by tie lines is an alternative to enhance reliability/redundancy in areas where there are a number of substations in close vicinity, such as a campus with three or four multi-storeyed blocks, each with a substation. Ring main type of distribution is preferred for complexes having a number of substations.

5.3.6 Medium or Low Voltage Switchgear and Controlgear and their Assemblies

5.3.6.1 The selection of the type of medium or low voltage switchgear for any installation *inter alia* depends upon the following:

- a) Voltage of the distribution system;
- b) Prospective circuit current at the point at which the switchgear is proposed;
- c) Prospective short-circuit current at which the switchgear is proposed;
- d) Accommodation available; and
- e) Nature of industry.

The switchgear and controlgear and their assemblies so selected shall comply with the relevant accepted standards [8-2(18)], other relevant Indian Standards, IEC 61439 (Part 1) : 2011 'Low-voltage switchgear and controlgear assemblies — Part 1: General rules' (*under publication* as adopted Indian Standard) and IEC 61439 (Part 2): 2011 'Low-voltage switchgear and controlgear assemblies — Part 2: Power switchgear and controlgear assemblies' (*under publication* as adopted Indian Standard).

5.3.6.2 Switchgear (and its protective device) shall

have breaking capacity not less than the anticipated fault level in the system at that point. System fault level at a point in distribution systems is predominantly dependent on the transformer size and its reactance. Parallel operation of transformers increases the fault level.

5.3.6.3 Where two or more transformers are to be installed in a substation to supply a medium voltage distribution system, the distribution system shall be divided into separate sections, each of which shall be normally fed from one transformer only unless the medium voltage switchgear has the requisite short-circuit capacity. Provision may, however, be made to interconnect separate sections, through a bus coupler in the event of failure or disconnection of one transformer. See 4.2 for details of location and requirements of substation.

5.3.6.4 Isolation and controlling circuit breaker shall be interlocked so that the isolator cannot be operated unless the corresponding breaker is in open condition. The choice between alternative types of equipment may be influenced by the following considerations:

- a) In certain installations supplied with electric power from remote transformer substations, it may be necessary to protect main circuits with circuit-breakers operated by earth fault, in order to ensure effective earth fault protection.
- b) Where large electric motors, furnaces or other heavy electrical equipment is installed, the main circuits shall be protected from short-circuits by switch disconnector fuse or circuit breakers. For motor protection, the combination of contactor overload device and fuse or circuit breakers shall have total coordination at least for motor ratings up to 10 kW, and for ratings above 10 kW, it shall be Type 2 coordination in accordance with relevant part of accepted standards [8-2(18)]. Wherever necessary, back up protection and earth fault protection shall be provided to the main circuit.
- c) Where means of isolating main circuits is separately required, switch disconnector fuse or switch disconnector may form part of main switchboards.

5.3.6.5 It shall be mandatory to provide power factor improvement capacitor at the substation bus. Suitable capacitor may be selected in consultation with the capacitor as well as switchgear manufacture depending upon the nature of electrical load

anticipated on the system. Necessary switchgear/feeder circuit breaker shall be provided for controlling of capacitor bank.

Power factor of individual motor may be improved by connecting individual capacitor banks in parallel. For higher range of motors, which are running continuously without much variation in load, individual power factor correction at load end is advisable.

NOTE — Care should be taken in deciding the kVAr rating of the capacitor in relation to the magnetizing kVA of the motor. Over rating of the capacitor may cause injury to the motor and capacitor bank. The motor still rotating after disconnection from the supply, may act as generator by self-excitation and produce a voltage higher than supply voltage. If the motor is again switched on before the speed has fallen to about 80 percent of the normal running speed, the high voltage will be superimposed on the supply circuits and will damage both the motor and the capacitor.

As a general rule, the kVAr rating of the capacitor should not exceed the no-load magnetizing kVA of the motor.

Generally it will be necessary to provide an automatic control for switching on the capacitors matching the load power factor and the bus voltage. Such a scheme will be necessary as capacitors permanently switched in the circuit may cause over voltage at times of light load. Capacitor panel shall be provided with adequate ventilation facility.

5.3.6.6 Harmonics on the supply systems are becoming a greater problem due to the increasing use of electronic equipment, computer, fluorescent lamps, LEDs and CFLs (both types have control/driver circuits operating in switch mode), mercury vapour and sodium vapour lighting, TV, microwave ovens, latest air conditioners, refrigerators, controlled rectifier and inverters for variable speed drives, power electronics and other non-linear loads. Harmonics may lead to almost as much current in the neutral as in the phases. This current is almost third, fifth, seventh and ninth harmonic. In such cases, phase rectification devices may be considered at the planning stage itself for the limits of harmonic voltage distortion.

With the wide spread use of thyristor and rectifier based loads, there is a necessity of providing a full size neutral; but this requirement is generally limited to the 3-phase 4-wire distribution generally in the 415/240 V.

5.3.6.7 *MV/LV Bus bar chambers*

Bus bar chambers, which feed two or more circuits, shall be controlled by a main disconnector (TP&N)

or TPN MCB to enable them to be disconnected from the supply.

5.3.6.8 Sufficient clearances as below shall be provided for isolating the switchboard to allow access for servicing, testing and maintenance (see Fig. 2):

- a) A clear space of not less than 1 m in width shall be provided in front of the switchboard.
 NOTE — In case the board has a shutter in the front for aesthetic reasons, provided the opening of the shutter shall satisfy the requirement of working/safety space of 1 m in front of the switchgear.
- b) If there are any attachments or bare connections at the back of the switchboard, the space, if any, behind the switchboard shall be either less than 200 mm or more than 750 mm in width, measured from the farthest protruding part of any attachment or conductor.
- c) If the space behind the switchboard exceeds 750 mm in width, there shall be a passageway from either end of the switchboard, clear to a height of 1.8 m.
- d) If two switchboards are facing each other, a minimum distance of 2.0 m shall be maintained between them.

The connections between the switchgear mounting and the outgoing cable up to the wall shall be enclosed in a protection pipe.

There shall be a clear distance of not less than 250 mm between the board and the insulation cover, the distance being increased for larger boards in order that on closing of the cover, the insulation of the cables is not subjected to damage and no excessive twisting or bending in any case. The cable alley in the metal board should enable within prescribed limit twisting or bending of cable such that insulation of the cables is not subjected to damage.

In this connection, for installation of voltages exceeding 250 V, Regulation 37 of *Central Electricity Authority (Measures Relating to Safety and Electricity Supply) Regulations, 2010*, as amended from time-to-time shall also be complied with (see Annex B).

5.3.6.9 Sufficient additional space shall be allowed in substations and switchrooms to allow operation and maintenance. Sufficient additional space shall be allowed for temporary location and installation of standard servicing and testing equipment. Space should also be provided to allow for anticipated future extensions.

5.3.6.10 Panels in a room or cubicle or in an area surrounded by wall/fence, access to which is controlled by lock and key shall be accessible to authorized persons only.

Such installations shall be efficiently protected by fencing not less than 1 800 mm in height or other means so as to prevent access to the electric supply lines and apparatus therein by an undesignated person and the

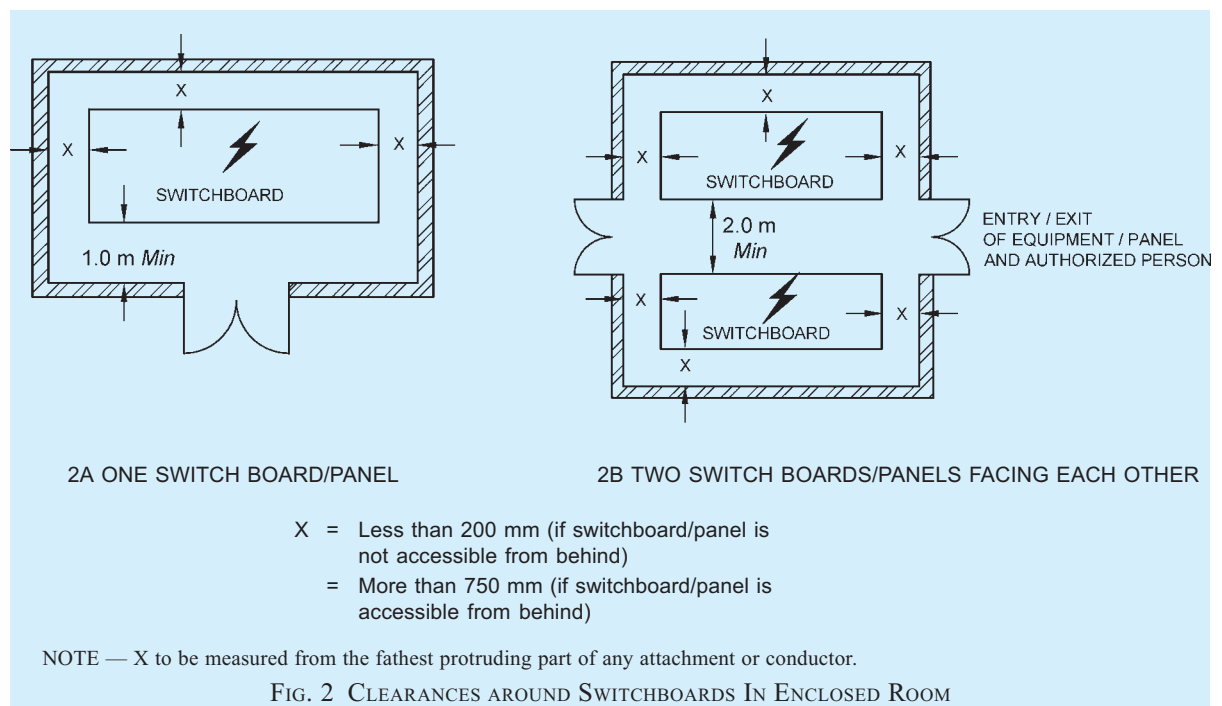

fencing of such area shall be earthed efficiently. Sufficient clearances as per 5.3.6.8 shall be provided between the switchboard and the wall/fence.

5.3.6.11 Except main LV panel, it will be preferable to locate the sub-panels/distribution boards/sub-meter boards near the load centre. Further, it should be ensured that these panels are easily approachable. The panels should have clear access from common areas excluding staircase.

Where the switchboard is erected in a room of a building isolated from the source of supply or at a distance from it, adequate means of control and isolation shall be provided both near the boards and at the origin of supply. Sufficient clearances as per 5.3.6.8 shall be provided.

5.3.6.12 All switchboards shall be of metal clad totally enclosed type or any insulated enclosed pattern.

5.3.7 Medium or Low Voltage Cables

5.3.7.1 The sizing of the cable shall depend upon the current to be carried, method of laying cable, permissible maximum temperature it shall withstand, voltage drop over the length of the cable, the prospective short-circuit current to which the cable may be subjected, the characteristics of the overload protection gear installed, load cycle, thermal resistivity of the soil and the operating voltage {see also good

practice [8-2(11)]}.

It is desirable to use flame retardant cables and wires in electrical distribution systems. Availability of flame retardant low smoke and halogen cable may also be noted and considered accordingly.

It is recommended to use four core cable in place of three and half core to minimize heating of neutral core due to harmonic content in the supply system and also avoidance of overload failures. All cables shall be installed in accordance with good practice [8-2(11)]. The advice of the cable manufacturer with regard to installation, jointing and sealing should also be followed.

In final circuits where cable size of 16 mm² and below are used, these shall be 4 core cables only to avoid the possibility of neutral overload, (except for equipment such as motors, heaters which offer balanced 3 phase load and do not require a neutral connection. As a result it is not desirable to use half-size neutral conductor as possibility of neutral conductor overload due to harmonics is likely. Larger feeders (size greater than 16 mm²) may revert to use 3½ core cables.

5.3.7.2 Colour identification of cores of non-flexible cables {see also good practice [8-2(19)]}

The colour of cores of non-flexible cables shall be in accordance with the following:

Sl No.	Function	Colour Identification of Core of Rubber of PVC Insulated Non-flexible Cable, or of Sleeve or Disc to be Applied to Conductor or Cable Code
(1)	(2)	(3)
i)	Protective or earthing	Green and yellow (see Note 1)
ii)	Phase of a.c. single-phase circuit	Red [or yellow or blue (see Note 2)]
iii)	Neutral of a.c. single or three-phase circuit	Black
iv)	Phase R of 3-phase a.c. circuit	Red
v)	Phase Y of 3-phase a.c. circuit	Yellow
vi)	Phase B of 3-phase a.c. circuit	Blue
vii)	Positive of d.c. 2-wire circuit	Red
viii)	Negative of d.c. 2-wire circuit	Black
ix)	Outer (positive or negative) of d.c. 2-wire circuit derived from 3-wire system	Red
x)	Positive of 3-wire system (positive of 3-wire d.c. circuit)	Red
xi)	Middle wire of 3-wire d.c. circuit	Black
xii)	Negative of 3-wire d.c. circuit	Blue
xiii)	Functional earth-telecommunication	Cream

NOTES

- 1 Bare conductors are also used for earthing and earth continuity conductors. But it is preferable to use insulated conductors with green coloured insulation with yellow stripes.
- 2 As alternative to the use of red, yellow or blue colour may be used, if desired in large installations, up to the final distribution board.
- 3 For armoured PVC-insulated cables and paper-insulated cables, see relevant Indian Standard.

5.3.7.3 Colour, identification of cores of flexible cables and flexible cords {see also good practice [8-2(19)]}

The colour of cores of flexible cables and flexible cords shall be in accordance with the following:

Sl No.	Number of Cores	Function of Core	Colour(s) of Core
(1)	(2)	(3)	(4)
i)	1	Phase	Brown ¹⁾
		Neutral	(Light) Blue
		Protective or earthing	Green and yellow
ii)	2	Phase	Brown
		Neutral	(Light) Blue ¹⁾
iii)	3	Phase	Brown
		Neutral	(Light) Blue ¹⁾
		Protective or earthing	Green and yellow
iv)	4 or 5	Phase	Brown or black ¹⁾
		Neutral	(Light) Blue ¹⁾
		Protective or earthing	Green and yellow

¹⁾ Certain alternatives are allowed in wiring regulations.

5.3.8 MV/LV Bus bar Trunking/Rising Mains

5.3.8.1 Where heavy loads and/or multiple distribution feeders are required to be supplied, busbar/rising main systems are preferred. The busbars are available for continuous run from point to point or with tap offs at standard intervals and have to be chosen as per specific requirement. Seismic supports shall be provided for bus trunking having continuous straight lengths of more than 24 m at a single stretch. There are following two types of MV/LV bus duct systems for power distribution:

- a) Conventional type; and
- b) Compact and sandwich type.

5.3.8.1.1 Conventional type bus duct

These are used for large power handling between transformer and switchgear or between switchgear and large power loads such as compressor drive motor, etc. This type is generally used in plant rooms, riser shafts, substations, etc. These are generally air insulated with intermediate ceramic support insulators enclosed in a metallic enclosure, which should be earthed. They have the least amount of combustible material. However, when these are crossing different fire compartments, they shall have fire barriers of same rating as that of the compartment (see also Part 4 ‘Fire and Life Safety’ of the Code).

Conventional type bus ducts with non-metallic enclosures are also available. However, such bus ducts shall be used only, if essential and with appropriate additional care.

5.3.8.1.2 Compact type bus duct

Compact type bus ducts are used within areas of the building which have space restrictions, etc, for aesthetic and functional reasons. These are either air insulated or sandwich type. They may be used in false ceiling spaces or even in corridors and shafts for distribution without any false ceiling as they provide an aesthetically acceptable finish to merge with other building elements such as beams, ducts or pipes in functional buildings.

The insulation material in such ducts are generally glass fibre tape or epoxy encapsulation in combination with ceramic supports/spacers. These bus ducts should be duly enclosed by a metallic enclosure, which should be earthed.

In case of compact air insulated type bus ducts crossing different fire compartments, they shall have fire barriers of same rating as that of the compartment (see also Part 4 ‘Fire and Life Safety’ of the Code).

5.3.8.2 The bus duct system shall be coordinated with connecting switchgear so as to provide adequate protection.

5.3.8.3 Seismic supports shall be provided for busbar trunking having continuous straight lengths of more than 24 m at a single stretch.

5.3.8.4 Where the number of individual units/flats/shops/offices on a floor in a building are more than 24, multiple rising mains are recommended for power distribution.

5.3.8.5 The low voltage bus bar trunking shall conform to accepted standard [8-2(20)].

5.4 Reception and Distribution of Main Supply

5.4.1 Control at Point of Commencement of Supply

5.4.1.1 The supplier shall provide a suitable metering switchgear in each conductor of every service line other than an earthed or earth neutral conductor or the earthed conductor of a concentric cable within a consumer’s premises, in an accessible position and such metering switchgear shall be contained within adequately enclosed fireproof receptacle. Where more than one consumer is supplied through a common service line, such consumer shall be provided with an independent metering switchgear at the point of rigid junction to the common service. Every electric supply line other than the earthed or earthed neutral conductor of any system or the earthed external conductor of a concentric cable shall be protected by a suitable switchgear by its

owner. In this connection, Regulation 14 and 41 of *Central Electricity Authority (Measures Relating to Safety and Electricity Supply) Regulations, 2010*, as amended from time-to-time shall also be complied with (see Annex B).

In case of high rise buildings, the supplier or owner of the installation shall provide at the point of commencement of supply a suitable isolating device with cut-out or breaker to operate on all phases except neutral in the 3-phase, 4-wire circuit and fixed in a conspicuous position at not more than 1.7 m above the ground so as to completely isolate the supply to the building in case of emergency. In this connection, Regulation 36 of *Central Electricity Authority (Measures Relating to Safety and Electricity Supply) Regulations, 2010*, as amended from time-to-time shall also be complied with (see Annex B).

The supplier shall provide and maintain on the consumer's premises for the consumer's use, a suitable earthed terminal in an accessible position at or near the point of commencement of supply. In this connection, Regulation 16 of *Central Electricity Authority (Measures Relating to Safety and Electricity Supply) Regulations, 2010*, as amended from time-to-time shall also be complied with (see Annex B).

No cut-out, link or switch other than a linked switch arranged to operate simultaneously on the earthed or earthed neutral conductor and live conductor shall be inserted or remain inserted in any earthed or earthed neutral conductor of a two wire-system or in any earthed or earthed neutral conductor of a multi-wire system or in any conductor connected thereto. This requirement shall however not apply in case of,

- a) a link for testing purposes, or
- b) a switch for use in controlling a generator or transformer.

In this connection, Regulation 15 (ii) of *Central Electricity Authority (Measures Relating to Safety and Electricity Supply) Regulations, 2010*, as amended from time-to-time shall also be complied with (see Annex B).

The neutral shall also be distinctly marked.

5.4.1.2 The main switch shall be easily accessible and situated as near as practicable to the termination of service line.

5.4.1.3 Where the conductors include an earthed conductor of a two-wire system or an earthed neutral conductor of a multi-wire system or a conductor which is to be connected thereto, an indication of a permanent nature shall be provided for identification in accordance with Regulation 15 (i) of *Central Electricity Authority (Measures Relating to Safety and Electricity Supply) Regulations, 2010*, as amended from time-to-time (see Annex B).

5.4.1.4 Energy meters

5.4.1.4.1 Energy meters conforming to accepted standards [8-2(21)] and other relevant Indian Standards shall be installed in all buildings at such a place which is readily accessible to the owner/operator/occupant of the building and the Authority. Meters should not be located at an elevated area or a depressed area that does not have access by means of a stairway of normal rise. The height of meter display shall be between 750 mm and 1 800 mm. In case the meter is provided with a secondary display unit, this requirement applies to the secondary display unit only. A minimum clearance of 50 mm should be maintained around the meter itself for better inspection. This includes the space between two meters, or between meter and the mounting box, or between two mounting boxes as the case may be. The energy meters should either be provided with a protecting covering, enclosing it completely except the glass window through which the readings are noted or should be mounted inside a completely enclosed panel provided with hinged arrangement for locking. Additionally, for outdoor installations, the meters and associated accessories shall be protected by appropriate enclosure of level of protection IP 55 and ensuring compliance with above conditions. The enclosure should preferably be light coloured.

In large multi-storeyed buildings, installation of a large number of energy meters at the ground floor (or first basement) switch-room for the convenience of the meter-reader poses high fire hazard. More than 24 energy meters on one switchboard is undesirable. In such cases, where number of energy meters to be installed for feeding exceeds 24, energy meters shall be installed at each floor and therefore, the rising main (bus trunking) with tapping point at individual floor shall be provided for meters.

The energy meters shall be protected by suitable circuit breaker. The provisions of **5.3.6.8** shall apply in case of energy meters installed in boards.

5.4.1.4.2 Main sources of energy, as given below shall be metered, as required at entry into the premise/control panel:

- 1) Utility grid points (high voltage/medium voltage/low voltage),
- 2) Captive generator sets, and
- 3) On-site renewable energy system (if installed/operational).

5.4.1.4.3 Testing, evaluation, installation and maintenance of energy meters shall be in accordance with the good practice [8-2(22)].

5.4.1.4.4 Centralized metering system

Smart metering and energy monitoring in a centralized

metering system are used to monitor, measure, and control the demand of electrical loads in a building. These systems are designed specifically for the control and monitoring of those facilities in a building which have significant electrical consumption, such as heating, ventilation, air conditioning, lifts, pumps, and lighting installations at multiple locations in a campus. The scope may span from a single building to a group of buildings, such as residential apartments under common ownership, large multi-storeyed buildings, malls, university campuses, office buildings, retail store networks, factories, or any building with multi-tenanted occupancy. These systems provide metering, submetering and monitoring functions to allow facility and building managers to gather data and insight that allow them to make more informed decisions about demand management and demand control across their sites.

For such buildings with centralized metering, several main meters and sub-meters with following requirements should be provided:

- a) Main meters should be digital energy meters with high accuracy, high sampling rates and power quality parameters, that is, harmonics, etc, for meters installed at incomer level.
- b) Separate sub-meters should be provided for all energy end uses and functional areas that individually account for reasonable energy consumption in the building. These may include, but are not limited to, sub-meters for HVAC system; common area lighting, raw power, UPS, other common utility; lifts and escalators, pumps, external and internal lighting, individual units/flats/shops/ offices; etc.
- c) The sub-meters should be able to communicate data for monitoring. At a minimum, the sub-metering infrastructure should facilitate the aggregation of total energy use.
- d) Adequate smart metering and energy monitoring infrastructure should be installed in order to help monitor operational energy use and costs and to enable continuous energy performance improvement.

Smart metering and energy monitoring system that can display the following parameters should be installed with two-way communicable smart meters:

- 1) Hourly energy demand and use;
- 2) Energy breakdown and mix and energy consumption patterns;
- 3) Power quality analysis;
- 4) Energy consumption by process, department, building, floor, etc;

- 5) Comparison of actual energy use with targets or historical trends and benchmark energy key performance indicators; and
- 6) Reporting on energy efficiency achieved.

These systems should also have the ability to utilize near-real-time or time-of-use pricing through integration of smart meters with the monitoring and control system. The system should be capable of supporting predictive demand for better demand management and proactive demand control.

5.4.1.4.5 The *Central Electricity Authority (Installation and Operation of Meters) Regulations 2006*, as amended from time-to-time shall also be complied with.

5.4.2 *Main Switches and Switchboard*

5.4.2.1 All main switches shall be either of metal-clad enclosed pattern or of any insulated enclosed pattern which shall be fixed at close proximity to the point of entry of supply. Every switch shall have suitable ingress protection level rating (IP), so that its operation is satisfactory and safe in the environment of the installation.

NOTE — Woodwork shall not be used for the construction or mounting of switches and switch boards installed in a building.

5.4.2.2 *Location*

The main switchboard shall comply with the following requirements relating to its location:

- a) The location of the main board should be such that it is easily accessible to firemen and other personnel to quickly disconnect the supply in case of emergencies. If the room is locked for security reasons, means of emergency access, by schemes such as break glass cupboard, shall be incorporated.
- b) Main switch board shall be installed in rooms or fire safe cupboards so as to safeguard against operation by unauthorized personnel. Otherwise the main switch board shall have lock and key facility for small installations in residences or other occupancies having sanctioned loads less than 5 kW.
- c) Switchboards shall be placed only in dry situations and in ventilated rooms and they shall not be placed in the vicinity of storage batteries or exposed to chemical fumes.
- d) In damp situation or where inflammable or explosive dust, gas or vapour is likely to be present, the switchboard shall be totally enclosed and shall have adequate degree of ingress protection (IP). In some cases flameproof enclosure may be necessitated by particular circumstances [see 8-2(23)].

- e) Switchboards shall not be erected above gas stoves or sinks, or within 2.5 m of any washing unit in the washing rooms or laundries, or in bathrooms, lavatories or toilets, or kitchens.
- f) In case of switchboards unavoidably fixed in places likely to be located outdoors, exposed to weather, to drip, or to abnormal moist temperature, the outer casing shall be weatherproof and shall be provided with glands or bushings or adopted to receive screwed conduit, according to the manner in which the cables are run. The casing as well as cable entries shall have suitable IP ratings according to the installation.
- g) Adequate illumination shall be provided for all working spaces around the switchboards.
- h) Easy access to the enclosure around switchgear is essential to enable easy and safe operation and maintenance. The provisions as given in 5.3.6.8 including requirements for sufficient clearances shall be complied with.

5.4.2.3 Metal-clad switchgear shall be mounted on any of the following types of boards:

- a) *Hinged-type metal boards* — These shall consist of a box made of sheet metal not less than 2 mm thick and shall be provided with a hinged cover to enable the board to swing open for examination of the wiring at the back. The board shall be securely fixed to the wall by means of proper nuts and bolts designed to take weight of the switch board and shall be provided with a locking arrangement and an earthing and neutral stud or bus. All wires passing through the metal board shall be protected by cable termination glands at the entry hole. The earth stud should commensurate with the size of earth lead/leads. Alternatively, metal boards may be made of suitable size iron angle section of minimum size 35 mm × 35 mm × 6 mm or iron channel section of minimum size 35 mm × 25 mm × 6 mm frame work suitably mounted on front with a 3 mm thick mild steel plate and on back with 1.5 mm thick mild steel sheet. No apparatus shall project beyond any edge of panel. No fuse body shall be mounted within 25 mm of any edge of the panel.

NOTE — Such type of boards are particularly suitable for small switchboard for mounting metal-clad switchgear connected to supply at low voltages.

- b) *Fixed-type metal boards* — These shall consist of an angle or channel iron frame fixed on the wall or on floor and supported on the wall at the top, if necessary.

NOTE — Such type of boards are suitable for both small and large switchboards. They are particularly suitable for large switchboards for mounting number of switchgears or high capacity metal-clad switchgear or both in an arrangement which do not require rear access.

- c) *Protected-type switchboard* — A protected switchboard is one where all of the switchgear and conductors are protected by metal or halogen free plastic enclosures. They may consist of a metal/plastic cubicle panel, or an iron frame upon which metal-clad switchgears are mounted. They usually consist of a main switch, bus bars and circuit breakers or fuses controlling outgoing circuits.
- d) *Outdoor-type switchboard* — An outdoor-type switchboard is one which is totally enclosed and UV ray protected and having high ingress protection against dust and moisture and vermin-proof and high impact resistance (IP 55 or higher and IK 10). Such switchboards are of cubicle type and also provide high impact resistance. Cubicle type boards shall be with hinged doors interlocked with switch-operating mechanisms. The doors of these switchboards shall have facility to ensure that it is always in closed conditions. All such switches shall bear labels indicating their functions.

NOTE — Such switchboards shall be located away from areas likely to be crowded by the public.

Open type switchboards wherever existing in old buildings shall be phased out and replaced with protected-type switchboards with suitable circuit breakers.

5.4.2.4 *Recessing of boards*

Where so specified, the switchboards shall be recessed in the wall. Ample room shall be provided at the back for connection and at the front between the switchgear mountings (see 5.3.6.8).

5.4.2.5 *Marking of apparatus {see also good practices [8-2(24)]}*

Where a board is connected to voltage higher than 250 V, all the apparatus mounted on it shall be marked with the following colours to indicate the different poles or phases to which the apparatus or its different terminals may have been connected:

- a) *Alternating current (three-phase) system:*
Phase 1 – red, Phase 2 – yellow and Phase 3 – blue; and 1 Neutral – black
- b) *Direct current (three-wire system):*
2 outer wire, Positive – red and Negative – blue; and 1 Mid wire (Neutral) – black

Where four-wire three-phase wiring is done, the neutral shall be in one colour and the other three phase conductors in another colour (preferably brown) or shall be suitably tagged or sleeved to ensure fool proof identification.

NOTE — Generally brown colour identification is adopted for the phase conductors and black for neutral with additional tags or sleeves or coloured tapes at terminations.

Earth continuity conductor shall be marked with green colour or green with yellow line.

Where a board has more than one switchgear, each such switchgear shall be marked to indicate the section of the installation it controls. The main switchgear shall be marked as such. Where there is more than one main switchboard in the building, each such switchboard shall be marked to indicate the section of the installation and/or building it controls.

All markings shall be clear and permanent.

5.4.2.6 Drawings

Before proceeding with the actual construction, a proper drawing showing the detailed dimensions and design including the disposition of the mountings of the boards, which shall be symmetrically and neatly arranged for arriving at the overall dimensions, shall be prepared along the building drawing. Such drawings will show the mandatory clearance spaces if any, and clear height below the soffit of the beam required to satisfy regulations and safety considerations, so that other designers or installers do not get into such areas or spaces for their equipment.

5.4.3 Distribution Boards

A distribution board comprises one or more protective devices against over current and ensuring the distribution of electrical energy to the circuits. Distribution board shall provide plenty of wiring space, to allow working as well as to allow keeping the extra length of connecting cables, likely to be required for maintenance.

5.4.3.1 Main distribution board shall be provided with a circuit breaker on each pole of each circuit, or a switch with a fuse on the phase or live conductor and a link on the neutral or earthed conductor of each circuit. The switches shall always be linked.

All incomers should be provided with surge protection devices depending upon the current carrying capacity and fault level (*see 11*). Surge protecting devices should be provided with backup circuit breaker/fuses, wherever required.

5.4.4 Branch Distribution Boards

5.4.4.1 Branch MCB distribution boards shall be provided, along with earth leakage protective device (RCCB/RCD) in the incoming, with a fuse or a

miniature circuit breaker or both of adequate rating/ setting chosen on the live conductor of each sub-circuit and the earthed neutral conductor shall be connected to a common link and be capable of being disconnected individually for testing purposes. At least one spare circuit of the same capacity shall be provided on each branch distribution board. Further, the individual branching circuits (outgoing) shall be protected against over-current with miniature circuit breaker of adequate rating. In residential/industrial lighting installations, the various circuits shall be separated and each circuit shall be individually protected so that in the event of fault, only the particular circuit gets disconnected. In order to provide protection against electric shock due to leakage current for human being, a 30 mA RCCB/RCD shall be installed at distribution board incomer of buildings, such as residential, schools and hospitals. For all other buildings, a 100 mA RCCB/RCD will suffice for protection against leakage current.

In case of phase segregated distribution boards, earth leakage protective device shall be provided in the sub-incomer to provide phase wise earth fault protection. The provision of sub-incomer in distribution board shall be as per consumer requirement.

5.4.4.2 Common circuit shall be provided for installations at higher level (those in the ceiling and at higher levels, above 1 m, on the walls) and for installations at lower level but with separate switch control (sockets for portable or stationery plug in equipment). For devices consuming high power and which are to be supplied through supply cord and plug, separate wiring shall be done. For plug-in equipment provisions shall be made for providing RCCB/RCD protection in the distribution board.

5.4.4.3 It is preferable to have additional circuit for kitchen and bathrooms. Such sub-circuit shall not have more than a total of ten points of light, fans and 6 A socket outlets. The load of such circuit shall be restricted to 800 W and the wiring with 1.5 mm² copper conductor cable is recommended. If a dedicated circuit is planned for light fixtures, the load of such circuit shall be restricted to 400 W and the wiring with 1.5 mm² copper conductor cable is recommended. If a dedicated circuit is planned for 6A sockets the load of such a circuit shall be restricted to 800 W or a maximum of 8 numbers, whichever is lesser, controlling MCB should be sized accordingly. The wiring shall be with 1.5 mm² copper conductor cable. If a separate fan circuit is provided, the number of fans in the circuit shall not exceed ten. Power sub-circuit shall be designed according to the load but in no case shall there be more than two 16 A outlets on each sub-circuit which can be wired with 4 mm² for miscellaneous socket loads and shall be with 4 mm² copper conductor cable for equipment consuming more than 1 kW. Power sockets

complying with the accepted standards [8-2(25)] with current rated according to their starting load, wiring, MCB, etc, shall be designed for special equipment space heaters, air conditioners, heat pumps, VRF, etc.

For feeding final single phase domestic type of loads or general office loads it is advisable to introduce additional cables if required to allow lowering of short circuit rating of the switchgear required at user end. Use of hand held equipment fed through flexible cords is safe.

5.4.4.4 The circuits for lighting of common area shall be separate. For large halls 3-wire control with individual control and master control installed near the entrance shall be provided for effective conservation of energy. Occupancy sensors, movement sensors, lux level sensors, etc, may also be considered as switching options for lights, fans, TV, etc, for different closed spaces (*see also* Part 11 'Approach to Sustainability' of the Code).

5.4.4.5 Where daylight is abundantly available, particularly in large halls, lighting in the area near the windows likely to receive daylight shall have separate controls for lights, so that they can be switched off/ automatically reduce intensity selectively when daylight is adequate, while keeping the lights in the areas remote from the windows on (*see also* Part 11 'Approach to Sustainability' of the Code).

5.4.4.6 Circuits for socket outlets may be kept separate from circuits feeding fans and lights. Normally, fans and lights may be wired on a common circuit. In large spaces, circuits for fans and lights may also be segregated. Lights may have group control in large halls and industrial areas. While providing group control, consideration may be given for the nature of use of the area lit by a group. Consideration has to be given for the daylight utilization, while grouping, so that a group feeding areas near windows receiving daylight can be selectively switched off during daylight period.

5.4.4.7 The load on any low voltage sub-circuit shall not exceed 3 000 W. In case of a new installation, all circuits and sub-circuits shall be designed with an initial load of about 2 500 W, so as to allow a provision of 20 percent increase in load due to any future modification. Power sub-circuits shall be designed according to the load, where the circuit is meant for a specific equipment. Good practice is to limit a circuit to a maximum of three sockets, where it is expected that there will be diversity due to use of very few sockets in large spaces (example sockets for use of vacuum cleaner). General practice is to limit it to two sockets in a circuit, in both residential and non-residential buildings and to provide a single socket on a circuit for a known heavy load appliance such as air conditioner, cooking range, etc.

5.4.4.8 In wiring installations at special places like construction sites, stadia, shipyards, open yards in industrial plants, etc, where a large number of high wattage lamps may be required, there shall be no restriction of load on any circuit but conductors used in such circuits shall be of adequate size for the load and proper circuit protection shall be provided. The distribution boards (DBs) used in these areas shall be of UV resistant, double insulated type with IP 66 or higher degree of protection. Power tools and other temporary equipment connected to these DBs shall be sufficiently protected against electrical faults. Insulated IP 66 sockets complying with the accepted standards [8-2(25)] used in these DBs shall have interlocking facility in addition to protection to ensure safe plugging and unplugging of these equipment.

5.4.5 Location of Distribution Boards

- a) The distribution boards shall be located as near as possible to the centre of the load they are intended to control.
- b) These shall be fixed on suitable stanchion or wall and shall be accessible for replacement/ reset of protective devices, and shall not be more than 1.8 m from floor level.
- c) These shall be of either metal-clad type, or polycarbonate enclosure of minimum IP 42. But, if exposed to weather or damp situations, these shall be of the weatherproof type conforming to IP 55 and, if installed where exposed to explosive dust, vapour or gas, these shall be of flameproof type in accordance with accepted standards [8-2(26)]. In corrosive atmospheres, these shall be treated with anti-corrosive preservative or covered with suitable plastic compound.
- d) Where two and/or more distribution boards feeding low voltage circuits are fed from a supply of medium voltage, the metal case shall be marked 'Danger 415 Volts' and identified with proper phase marking and danger marks.
- e) Each shall be provided with a circuit list giving diagram of each circuit which it controls and the current rating of the circuit and size of fuse element.
- f) In wiring branch distribution board, total load of consuming devices shall be divided as far as possible evenly between the number of ways in the board leaving spare circuits for future extension.
- g) Distribution board shall not be located at structural expansion joints of the building.
- h) Distribution board/other electrical outlets shall have a minimum calculated separation distance from lightning protection down-

conductors to avoid flash over in case of lightning.

- j) Walls with flushed distribution boards shall have adequate support behind and surrounding so that there is no physical weight on the distribution board of the civil structure around. Electrical switch sockets, etc, shall also be avoided to be mounted behind the distribution board to avoid touching the board from behind.

5.4.6 Protection of Circuits

- a) Appropriate protection shall be provided at switchboards, distribution boards and at all levels of panels for all circuits and sub-circuits against short circuit, over-current and other parameters as required. The protective device shall be capable of interrupting maximum prospective short circuit current that may occur, without danger. The ratings and settings of fuses and the protective devices shall be coordinated so as to afford selectivity in operation and in accordance with accepted standards [8-2(27)].
- b) Where circuit-breakers are used for protection of a main circuit and of the sub-circuits derived therefrom, discrimination in operation may be achieved by adjusting the protective devices of the sub-main circuit-breakers to operate at lower current settings and shorter time-lag than the main circuit-breaker.
- c) Where HRC type fuses are used for back-up protection of circuit-breakers, or where HRC fuses are used for protection of main circuits, and circuit-breakers for the protection of sub-circuits derived there from, in the event of short-circuits protection exceeding the short-circuits protection exceeding the short-circuits capacity of the circuit-breakers, the HRC fuses shall operate earlier than the circuit-breakers; but for smaller overloads within the short-circuit capacity of the circuit-breakers, the circuit-breakers shall operate earlier than the HRC fuse blows.
- d) If rewirable type fuses are used to protect sub-circuits derived from a main circuit protected by HRC type fuses, the main circuit fuse shall normally blow in the event of a short-circuit or earth fault occurring on sub-circuit, although discrimination may be achieved in respect of overload currents. The use of rewirable fuses is restricted to the circuits with short-circuit level of 4 kA; for higher level either cartridge or HRC fuses shall be used. However, use of rewirable fuse is not desirable, even for lower fault level areas. MCB's provide a better and dependable

protection, as their current setting is not temperable.

- e) A fuse carrier shall not be fitted with a fuse element larger than that for which the carrier is designed.
- f) The current rating of a fuse or circuit breaker shall not exceed the current rating of the smallest cable in the circuit protected by the fuse.
- g) Every fuse shall have its own case or cover for the protection of the circuit and an indelible indication of its appropriate current rating in an adjacent conspicuous position.
- h) All distribution board or panel incomer may be protected by a surge protection device, if found necessary (*see 11*). Separate HRC fuse/CB with proper enclosure may be required in series with the surge protection device with main incomer. Back-up fuse/CB shall be of the capacity not lower than that recommended by the SPD manufacturer. Short circuit withstand capability of the SPDs should be coordinated with the HRC fuse/CB and SPD should be selected to be matching the fault power expected/calculated at that point.

5.4.7 Cascading, Discrimination and Limitation

Cascading and discrimination in switchgear downstream and upstream shall be designed and maintained such that the continuity of power in case of any abnormal conditions such as overload, short circuit and earth faults, etc is maintained and only faulty circuit is isolated and power is made available to other loads.

Cascading technique allows the designer to select circuit breakers of lower breaking capacities. Utilizing the current limiting effect of the incoming breaker, outgoing breaker can sustain the higher faults than its capacity and even maintain the discrimination.

5.5 Protection Class of Equipment and Accessories

The class of ingress protection (IP) and protection against mechanical impact (IK) {*see also* good practice [8-2(6)] and IEC 62262:2002 'Degrees of protection provided by enclosures for electrical equipment against external mechanical impacts (IK code)'} shall be specific depending on the requirement at the place of installation.

5.6 Voltage and Frequency of Supply

It should be ensured that all equipment connected to the system including any appliances to be used on it are suitable for the voltage and frequency of supply of the system. The nominal values of low and medium voltage systems in India are 240 V and 415 V a.c., respectively, and the frequency is 50 Hz.

NOTE — The design of the wiring system and the sizes of the cables should be decided taking into account following factors:

- a) *Voltage drop* — This should be kept below 6 percent to ensure proper functioning of all electrical appliances and equipment including motors;
- b) Thermal limit based current carrying capacity of the cable with appropriate derating factors applicable to the installation conditions;
- c) Capacity to withstand the let through fault current based on the fault level and the controlling switchgear disconnection characteristics.

5.7 Rating of Cables and Equipment

5.7.1 The current-carrying capacity of different types of cables shall be chosen in accordance with good practice [8-2(28)].

5.7.2 The current ratings of switches for domestic and similar purposes are 6 A, 16 A, 20 A and 25 A.

5.7.3 The current ratings of isolators and normal duty switches and composite units of switches and fuses shall be selected from one of the following values:

16, 25, 32, 63, 100, 160, 200, 320, 400, 500, 630, 800, 1 000 and 1 250 A.

5.7.4 The ratings of rewirable and HRC fuses shall be in accordance with good practice [8-2(29)].

5.7.5 The current ratings of miniature circuit-breakers shall be chosen from the values given below:

6, 10, 16, 20, 25, 32, 40, 50, 63, 80, 100 and 125 A.

5.7.6 The current ratings of moulded case circuit breakers shall be chosen from the values given below:

100, 125, 160, 200, 250, 315, 400, 630, 800, 1 000, 1 250 and 1 600A.

5.7.7 The current ratings of air circuit-breakers shall be chosen from the values given below:

630, 800, 1 000, 1 250, 1 600, 2 000, 2 500, 3 200, 4 000A and 6 300 A.

5.7.8 The current ratings of the distribution fuse board shall be selected from one of the following values:

6, 16, 25, 32, 63 and 100 A.

5.8 Installation Circuits

5.8.1 The nominal cross-sectional area of copper phase conductors in a.c. circuits and of live conductors in d.c. circuits shall be not less than the values specified below:

<i>Sl No.</i>	<i>Type of Circuit</i>	<i>Minimum Copper Wire Size</i>	<i>Number of Circuits</i>
(1)	(2)	(3)	(4)
i)	Lighting	1.5 mm ²	2 or more
ii)	Socket-outlets, 6 A	2.5 mm ²	Any number Areas such as kitchens and laundries 3 × double socket-outlets per circuit. Other areas up to 12 double socket-outlets
iii)	Signaling and control circuits	0.5 mm ² (see Note 1)	—
iv)	Socket-outlets, 16 A	2.5 mm ²	1
v)	Water heater < 3 kW	2.5 mm ²	1
vi)	Heaters or electric equipment more than or equal to 3 kW	4.0 mm ²	1
vii)	Free standing electric range Separate oven and/or cook top	4.0 mm ²	1
viii)	Air conditioner > 1.5 t	4.0 mm ²	1
ix)	Permanently connected appliances including dishwashers, heaters, etc	2.5 mm ²	1 above 10 A. Up to 10 A can be wired as part of a socket-outlet circuit
x)	Appliance rated >3 kW <6 kW	6.0 mm ²	—
xi)	Submains to garage or out-building	2.5 mm ²	1 for each
xii)	Mains cable	—	It should be based on demand load/peaking loads and future loading.

NOTE — In multi-core flexible cables containing 7 or more cores and in signalling control circuits intended for electronic equipment a minimum nominal cross-sectional area of 0.1 mm² is permitted.

5.8.2 Aluminum conductor cables in sizes less than 16 mm² cause termination problems leading to heating at the terminals and enhance the possibility of a fire. For conductor sizes less than or equal to 16 mm², only copper conductor cables should be used.

5.8.3 Switch or isolator controlling a water heater or geyser should not be located within 1 m from the location of a shower or bath tub, to avoid a person in wet condition reaching the switch or isolator. It is preferable to provide the control switch outside the bath room near the entrance and provide an indication at the water heater. A socket or a connector block with suitable protection against water spray should be provided to connect the water heater. The above considerations apply to switches for outdoor lights and other appliances, with the objective of avoidance of operation of a switch when a person is wet.

5.8.4 Sockets in kitchen, bathroom, toilet, garage, etc, should not be provided within a height of 1 m from the ground level. Similar care has to be taken for installations

involving fountains, swimming pools, etc. Light fittings in such areas should be fed at low voltage, preferably through an isolating transformer with a proper earth leakage protection. Where possibility of a person in contact with a wet surface has to operate or touch an electrical switch or an appliance the circuit should be protected by a 100/30 mA RCCB/RCD, as applicable.

5.8.5 *Selecting and Installing Cables*

5.8.5.1 *Cable insulation types*

For the purpose of this Code, cables above 1 mm² shall have stranded conductors. All cables when installed, shall be adequately protected against mechanical damage. This can be carried out by either having additional protection, such as being enclosed in PVC conduit or metal pipes, or placing the cables in a suitable location that requires no additional protection. The cables for wiring circuits in electrical installation shall have the appropriate wire size matching the requirement of the loads and the following table gives the recommendations for different types of loads:

For the mains cable	Tough plastic sheathed (TPS) cable
For installation wiring	Tough plastic sheathed (TPS) cables
For main earth or main equipotential wire	Poly vinyl chloride (PVC) insulated conduit wire
Underground installation and installation in cable trench, feeders between buildings, etc	PVC insulated, PVC sheathed armored cables or XLPE insulated, PVC sheathed cables armoured cables
Installation in plant rooms, switch rooms etc, on cable tray or ladder or protected trench, where risk of mechanical damage to cable does not exist.	PVC insulated, PVC sheathed or XLPE insulated, PVC sheathed unarmoured cables

5.8.5.2 *Circuit wire sizes*

Recommended minimum wire sizes for various circuits is given below:

<i>Sl No.</i>	<i>Circuits</i>	<i>Minimum Wire Size</i>	<i>Wire Colour</i>
(1)	(2)	(3)	(4)
i)	1-way lighting	2 + E cable wires 1.5 mm ²	Red-Black-Green or Green/Yellow
ii)	2-way lighting control (straps between the 2 switches)	3 wire cable 1.5 mm ²	Red-White-Blue
iii)	Storage water heaters up to 3 kW	2 + E cable 2.5 mm ² (stranded conductors)	Red-Black-Green or Green/Yellow
iv)	Storage water heaters between 3 kW and 6 kW	2 + E cable 4 mm ² (stranded conductors)	Red-Black-Green or Green/Yellow
v)	Socket-outlets and permanent connection units	2 + E cable 2.5 mm ² (stranded conductors)	Red-Black-Green or Green/Yellow
vi)	Submains to garages or out buildings	2 + E cable 2.5 mm ² (stranded conductors)	Red-Black-Green or Green/Yellow

<i>Sl No.</i>	<i>Circuits</i>	<i>Minimum Wire Size</i>	<i>Wire Colour</i>
(1)	(2)	(3)	(4)
vii)	Cooking hobs	2 + E cable	Red-Black-Green or
viii)	Separate ovens	1.5 mm ² 2 + E cable 4 mm ² (stranded conductors)	Green/Yellow
ix)	Electric range	2 + E cable 6 mm ² (stranded conductors)	Red-Black- Green or Green/Yellow
x)	Mains	2 wire cable 16 mm ² (stranded conductors)	Red-Black
xi)	Main equipotential bonding wire	Conduit wire 4 mm ² (stranded conductors)	Green or Green/Yellow
xii)	Main earth wire	Conduit wire 6 mm ² (stranded conductors)	Green or Green/Yellow

NOTES

1 2 + E is also known as twin and earth.

2 Earth wire can be as per the following:

a) Green/Yellow throughout their length with, in addition, light blue markings at the terminations, or

b) Light blue throughout their length with, in addition, green/yellow markings at the terminations.

3 The above sizes are recommendatory and shall be modified as per voltage drop, starting current, distance from DB, etc.

5.8.6 Requirements for Physical Protection of Underground Cables

<i>Sl No.</i>	<i>Protective Element</i>	<i>Specifications</i>
(1)	(2)	(3)
i)	Bricks	(a) 100 mm minimum width (b) 25 mm thick (c) sand cushioning 100 mm and sand cover 100 mm
ii)	Concrete slabs	At least 50 mm thick
iii)	Plastic slabs (polymeric cover strips) Fibre reinforced plastic	At least 10 mm thick, depending on properties and has to be matched with the protective cushioning and cover
iv)	PVC conduit or PVC pipe or stoneware pipe or hume pipe	The pipe diameter should be such so that the cable is able to easily slip down the pipe
v)	Galvanized pipe	The pipe diameter should be such so that the cable is able to easily slip down the pipe

The trench shall be backfilled to cover the cable initially by 200 mm of sand fill; and then a plastic marker strip shall be put over the full length of cable in the trench. The marker signs shall be provided where any cable enters or leaves a building. This will identify that there is a cable located underground near the building. The trench shall then be completely filled. If the cables rise above ground to enter a building or other structure, a mechanical protection such as a GI pipe or PVC pipe for the cable from the trench depth to a height of 2.0 m above ground shall be provided.

5.9 Lighting and Levels of Illumination

5.9.1 General

Lighting installation shall take into consideration many factors on which the quality and quantity of artificial lighting depends. Recent practice in illumination is to provide the required illumination with a large number of light sources (not of higher illumination level) instead of fewer number of light sources of higher illumination level, to produce higher uniformity in illumination level.

Now a wide variety of light sources, such as, fluorescent lamps [tubular (TL) and compact (CFL)], light emitting diodes (LED) and induction lighting are available in addition to the incandescent lamps (GLS and halogen), for application in buildings. Most of them are competitive when applied in the segment for which a particular type is well suited.

With the increase in energy costs and awareness of the need to conserve energy for the protection of the

environment, lighting design is becoming complex. With the developments in the types of light sources and their control systems now available, lighting design goes with the concept of better light with less energy and least impact on environment.

Automatic lighting control schemes may be considered to have efficient utilization of lights. Automatic controls can take care of the switching off when the space served has no activity or is illuminated by daylight.

5.9.2 Electrical Installations for Lighting

The concepts or needs of energy conservation today require more lights to be provided so that different sets of lights are used to light up the area of activity to the required higher level of lighting needed for the activity and provide a general minimum background level of lighting. Any space requires two or three different combination of lighting sets associated with the activity and this may require the wiring to be provided to accommodate the lighting groups in different circuits with group controls, automatic controls and remote controls.

Availability of LED lights with a wide range from 1 W to 100 W allows designers to provide spot task lighting of a high illumination level combined with a general space lighting of low illumination. As light follows the inverse square law, provision of the light source close to the task reduces the energy need.

Lighting demand for buildings should be considered as per type of building. Where nothing is specified, for lighting demand of any type of building a maximum of 13 W/m² of all built-up areas including balconies. Covered parking areas may be considered at 3.23 W/m² including balconies, service areas, corridors, etc, may be considered with very basic diversity of 80 percent to 100 percent. Power requirements shall be considered at least 55 W/m² with an overall diversity not exceeding 50 percent. These shall be excluding defined loads such as lifts, plumbing system, fire fighting systems, ventilation requirement, etc.

While incandescent lamps (GLS or halogen) does not require any control gear, other light sources such as tubular fluorescent lamps, compact fluorescent lamps, mercury vapour lamps, sodium vapour lamps, metal halide lamps and light emitting diode (LED) lamps have non-linear characteristics and require specifically made control gear for each type of lamp for their proper operation. In some cases the control gear is integral with the lamp and in some it is with light fitting and in some it is external. The electrical installation and wiring has to take this into account and provide appropriate space for such control gear. There will be heat emission, introduction of harmonics etc, and they also consume some energy. The electrical and lighting system design has to keep this aspect in the wiring design and

installation. Control gear contributes or influences energy conservation significantly and due care should be taken to ensure a proper choice.

5.9.3 Principles of Lighting

When considering the function of artificial lighting, attention shall be given to the following principle characteristics before designing an installation:

- a) Illumination and its uniformity;
- b) Special distribution of light. This includes a reference to the composition of diffused and directional light, direction of incidence, the distribution of luminances and the degree of glare;
- c) Colour of the light and colour rendition;
- d) Natural light sources, if possible such as light tubes; and
- e) System wattage of the luminaire proposed.

5.9.4 The variety of purposes which have to be kept in mind while planning the lighting installation may be broadly grouped as:

- a) Industrial buildings and processes;
- b) Offices, schools and public buildings;
- c) Surgeries and hospitals; and
- d) Hostels, restaurants, shops and residential buildings.

5.9.4.1 It is important that appropriate levels of illumination for these and the types and positions of fittings determined to suit the task and the disposition of the working planes.

5.9.5 For detailed requirements for lighting and lighting design and installations, reference shall be made to National Lighting Code. For specific requirements for lighting of special occupancies, reference shall be made to good practice [8-2(30)] and the National Lighting Code.

5.9.6 Energy Conservation

Energy conservation may be achieved by using the following:

- a) Energy efficient lamps, chokes, ballast, etc, for lighting equipment.
- b) Efficient switching systems such as remote sensors, infrared switches, master switches, occupancy sensors, light sensors, light automation, remote switches, etc for switching 'ON' and 'OFF' of lighting circuits.
- c) Properly made/connected joints/contacts to avoid loose joints leading to loss of power.

5.10 In locations where the system voltage exceeds 650 V, as in the case of industrial locations, for details of design and construction of wiring installation,

reference may be made to good practice [8-2(11)].

5.11 Guideline for Electrical Layout in Residential Buildings

For guidelines for electrical installation in residential buildings, reference may be made to good practice [8-2(31)].

A typical distribution scheme in a residential building with separate circuits for lights and fans and for power appliances is given in Fig. 3.

5.12 For detailed information regarding the installation of different electrical equipment, reference may be made to good practice [8-2(32)].

6 WIRING

6.1 Provision for Maximum Load

All conductors, switches and accessories shall be of such size as to be capable of carrying, without their respective ratings being exceeded, the maximum current which will normally flow through them.

6.1.1 Estimation of Load Requirements

In estimating the current to be carried by any conductor the following ratings shall be taken, unless the actual values are known or specified for these elements:

<i>Sl No.</i>	<i>Element</i>	<i>Rating W</i>
(1)	(2)	(3)
i)	Incandescent lamp	60
ii)	Ceiling fan	60
iii)	Table fan	60
iv)	6 A socket outlet	100, unless the actual value of loads are specified
v)	16 A socket outlet	1 000, unless the actual value of loads are specified
vi)	Fluorescent light: Length :	
	a) 600 mm	25
	b) 1 200 mm	50
	c) 1 500 mm	90
vii)	High pressure mercury vapour (HPMV) lamps, high pressure sodium vapour (HPSV) lamps	According to their capacity, control gear losses shall be also considered as applicable
viii)	Compact fluorescent lamp (CFL)	20
ix)	Light emitting diode (LED)	10

<i>Sl No.</i>	<i>Element</i>	<i>Rating W</i>
(1)	(2)	(3)
x)	Exhaust fan	50
xi)	Geysers (storage type)	2 000
xii)	Geysers (instant)	3 000
xiii)	Computer point	150
xiv)	Computer (laptop)	50
xv)	Printer, laser	1 500
xvi)	Printer, inkjet	70
xvii)	Kitchen outlet	1 500
xviii)	Air conditioner:	
	1 TR	1 250
	1.5 TR	1 875
	2 TR	2 500
	2.5 TR	3 200

6.1.2 Electrical installation in a new building shall normally begin immediately on the commencement of the main structural building work and before finishing work such as plastering has begun except in the case of surface wiring which can be carried out after the plaster work. Usually, no installation work should start until the building is reasonably weatherproof, but where electric wiring is to be concealed within the structures as may be the case with a reinforced concrete building, the necessary conduits and ducts shall be positioned firmly by tying the conduit to the reinforcement before concreting. Care should be taken to avoid use of damaged conduit or ducts, the conduits end shall be given suitable anti-corrosive treatment and holes blocked off by putties or caps to protect conduits from getting blocked. All conduit openings and junction box openings, etc shall be properly protected against entry of mortar, concrete, etc, during construction.

6.2 Selection of Size of Conductors

The size of conductors of circuits shall be so selected that the drop in voltage from consumer’s terminals in a public supply (or from the bus-bars of the main switchboard controlling the various circuits in a private generation plant) to any point on the installation does not exceed three percent of the voltage at the consumer’s terminals (or at two bus-bars as these may be) when the conductors are carrying the maximum current under the normal conditions of service. The overall voltage drop from the transformer end to consumer’s final distribution board shall not exceed six percent.

6.2.1 If the cable size is increased to reduce voltage drop in the circuit, the rating of the cable shall be sufficient to carry the current which the circuit is designed for. In each circuit or sub-circuit the fuse/circuit-breaker shall be selected to match the current rating of the circuit to ensure the desired protection.

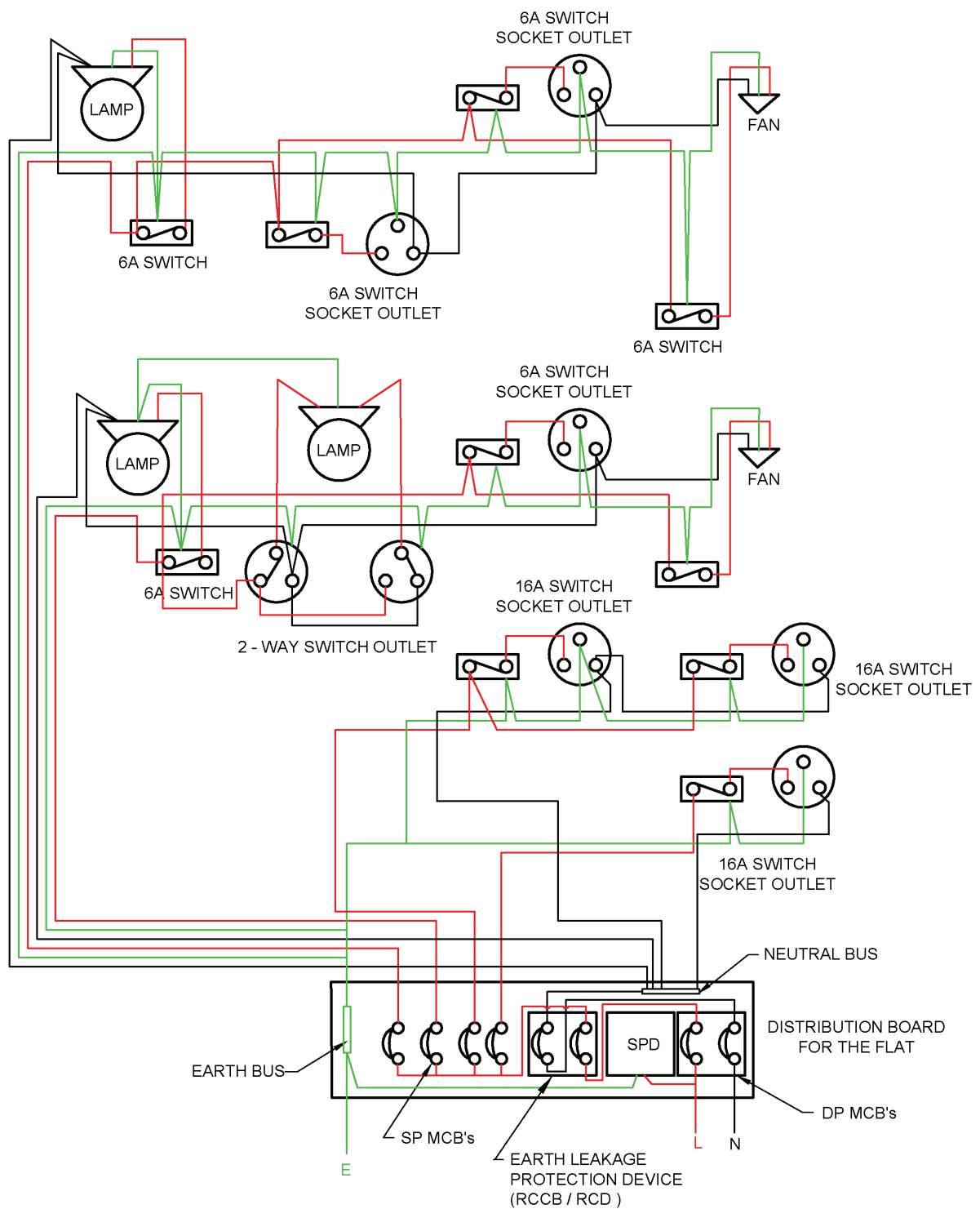

FIG. 3 WIRING DIAGRAM FOR A TYPICAL DISTRIBUTION SCHEME IN A RESIDENTIAL BUILDING FLAT

6.3 Branch Switches

Where the supply is derived from a three-wire or four-wire source, and distribution is done on the two-wire system, all branch switches shall be placed in the outer or live conductor of the circuit and no single phase switch or protective device shall be inserted in the middle wire, earth or earthed neutral conductor of the circuit. Single-pole switches (other than for multiple control) carrying not more than 16 A may be of tumbler type or flush type which shall be on when the handle or knob is down.

6.4 Layout and Installation Drawing

6.4.1 The electrical layout should be drawn indicating properly the locations of all outlets, such as, lamps, fans, appliances (both fixed and movable) and motors and best suit for wiring.

6.4.2 All runs of wiring and the exact positions of all points of switch-boxes and other outlets shall be first marked on the plans of the building and approved by the Engineer-in-Charge or the owner before actual commencement of the work.

6.4.3 Industrial layout drawings should indicate the relative civil and mechanical details.

6.4.4 *Layout of Wiring*

The layout of wiring should be designed keeping in view disposition of the lighting system to meet the illumination levels. All wirings shall be done on the distribution system with main and branch distribution boards at convenient physical and electrical load centres. All types of wiring, whether concealed or unconcealed should be as near the ceiling as possible. In all types of wirings due consideration shall be given for neatness and good appearance.

6.4.5 Balancing of circuits in three-wire or poly-phase installation shall be arranged beforehand. Proper balancing can be done only under actual load conditions. Conductors shall be so enclosed in earthed metal or incombustible insulating material that it is not possible to have ready access to them. Means of access shall be marked to indicate the voltage present.

Where terminals or other fixed live parts between which a voltage exceeding 250 V exists are housed in separate enclosures or items of apparatus which, although separated are within reach of each other, a notice shall be placed in such a position that anyone gaining access to live parts is warned of the magnitude of the voltage that exists between them.

Where loads are single phase, balancing should be for the peak load condition based on equipment usage. Facility for change should be built into the distribution design.

NOTE — The above requirements apply equally to three-phase circuits in which the voltage between lines or to earth exceeds 250 V and to groups of two or more single-phase circuits, between which medium voltage may be present, derived therefrom. They apply also to 3-wire d.c. or 3-wire single-phase a.c. circuits in which the voltage between lines or to earth exceeds 250 V and to groups of 2-wire circuits, between which medium voltage may be present, derived there from.

6.4.6 Medium voltage wiring and associated apparatus shall comply, in all respects, with the requirements of Regulation 35, 36, 37, 40, 41 and 42 of *Central Electricity Authority (Measures Relating to Safety and Electricity Supply) Regulations, 2010*, as amended from time-to-time (see Annex B).

6.5 Conductors and Accessories

6.5.1 *Conductors*

Conductors for all the internal wiring shall be of copper. Conductors for power and lighting circuits shall be of adequate size to carry the designed circuit load without exceeding the permissible thermal limits for the insulation. For final section wiring to larger loads, the current carrying capacity will preside. The conductor size shall also be based on the voltage drop in the line so as to provide a terminal voltage not below the prescribed voltage requirement.

The conductor for final sub-circuit for fan and light wiring shall have a nominal cross-sectional area not less than 1.50 mm² copper. The cross-sectional area of conductor for power wiring shall be not less than 2.5 mm² copper. The minimum cross-sectional area of conductor of flexible cord shall be 1.50 mm² copper.

In existing buildings where aluminum wiring has been used for internal electrification, changeover from aluminum conductor cables to copper conductor cables is recommended as it has been found that aluminum conductors below 10 mm² size pose a number of hazards.

NOTE — It is advisable to replace wiring, which is more than 30 years old as the insulation also would have deteriorated, and will be in a state to cause failure on the slightest of mechanical or electrical disturbance.

6.5.2 *Flexible Cables and Flexible Cords*

Flexible cables and cords shall be of copper and stranded and protected by flexible conduits or tough rubber or PVC sheath to prevent mechanical damage.

6.5.3 *Cable Ends*

When a stranded conductor having a nominal sectional area less than 6 mm² is not provided with cable sockets, all strands at the exposed ends of the cable shall be soldered together or crimped using suitable sleeve or ferrules.

6.5.4 *Special Risk*

Special forms of construction, such as flameproof

enclosures, shall be adopted where there is risk of fire or explosion.

6.5.5 Connection to Ancillary Buildings

Unless otherwise specified, electric connections to ancillary buildings, such as out-houses, garages, etc, adjacent to the main building and when no roadway intervenes shall be taken in an earthed GI pipe or heavy duty PVC or HDPE pipe of suitable size. This pipe can be taken either underground or over ground, however, in latter case, its height from the ground shall not be less than 5.8 m. This applies to both runs of mains or sub-mains or final sub-circuit wiring between the buildings.

6.5.6 Expansion Joints

Distribution boards shall be so located that the conduits shall not normally be required to cross expansion joints in a building. Where such crossing is found to be unavoidable, special care shall be taken to ensure that the conduit runs and wiring are not in any way put to strain or damaged due to expansion of building structure. Anyone of the following standard methods of connection at a structural expansion joint shall be followed:

- a) Flexible conduit shall be inserted at place of expansion joint.
- b) Oversized conduit overlapping the conduit.
- c) Expansion box.

Supports and flexible joints shall be of same requirement as the rising main/bus duct in so far as resistance to seismic forces is concerned. This is further important when rising mains and bus-ducts cross expansion joints.

6.5.7 Low Voltage (Types of Wires/Cables)

Low voltage services utilizes various categories of cables/wires, such as fibre optic cable, co-axial, category cable, etc. These shall be laid at least at a distance of 300 mm from any power wire or cable. The distance may be reduced only by using completely closed earthed metal trunking with metal separations for various kind of cable. Special care shall be taken to ensure that the conduit runs and wiring are laid properly for low voltage signal to flow through it.

The power cable and the signal or data cable may run together under floor and near the equipment. However, separation may be required from the insulation aspect, if the signal cable is running close to an un-insulated conductor carrying power at high voltage. All types of signal cables are required to have insulation level for withstanding 2 kV impulse voltage even if they are meant for service at low voltage.

6.6 Joints and Looping Back

6.6.1 Where looping back system of wiring is specified, the wiring shall be done without any junction or connector boxes on the line. Where joint box system is specified, all joints in conductors shall be made by means of suitable mechanical connectors in suitable joint boxes. Whenever practicable, only one system shall be adopted for a building, preferably a looping back system.

6.6.2 In any system of wiring, no bare or twist joints shall be made at intermediate points in the through run of cables unless the length of a final sub-circuit, sub-main or main is more than the length of the standard coil as given by the manufacturer of the cable. If any jointing becomes unavoidable such joint shall be made through proper cutouts or through proper junction boxes open to easy inspection, but in looping back system no such junction boxes shall be allowed.

6.6.3 Joints are a source of problems in reliability and are also vulnerable to fire. They should be avoided or at least minimized. They should under no circumstance exceed more than one to two in total length and distance between two shall not be less than 5 m. Joint should not be used as tap-off for multiple feeders. Where joints in cable conductors or bare conductors are necessary, they shall be mechanically and electrically sound. Joints in non-flexible cables shall be accessible for inspection; provided that this requirement shall not apply to joints in cables buried underground, or joints buried or enclosed in non-combustible building materials. Joints in non-flexible cables shall be made by soldering, brazing, welding or mechanical clamps, or be of the compression type; provided that mechanical clamps shall not be used for inaccessible joints buried or enclosed in the building structure. All mechanical clamps and compression type sockets shall securely retain all the wires of the conductors. Any joint in a flexible cable or flexible cord shall be effected by means of a cable coupler.

For flexible cables for small loads less than 1 kW, while it is desirable to avoid joints, if unavoidable, joints may be made either by splicing by a recognized method or by using a connector and protecting the joint by suitable insulating tape or sleeve or straight joint. For application of flexible cable for loads of 1 kW or more, if joint is unavoidable, crimped joint is preferred. Spliced joint should not be used for large loads.

There are different standard joints, such as epoxy resin based joint, heat shrinkable plastic sleeve joint, etc, and each one has its advantage and disadvantage. Selection has to be made on the basis of application, site conditions and availability of skilled licensed workmen trained in the application of the particular type of joint.

6.6.4 Every joint in a cable shall be provided with insulation not less effective than that of the cable cores and shall be protected against moisture and mechanical damage. Soldering fluxes which remain acidic or corrosive at the completion of the soldering operation shall not be used.

For joints in paper-insulated metal-sheathed cables, a wiped metal sleeve or joint box, filled with insulating compound, shall be provided.

Where an aluminum conductor and a copper conductor are joined together, precautions shall be taken against corrosion and mechanical damage to the conductors.

6.6.5 Pull at Joints and Terminals

Every connection at a cable termination shall be made by means of a terminal, soldering socket, or compression type socket and shall securely contain and anchor all the wires of the conductor, and shall not impose any appreciable mechanical strain on the terminal or socket.

Flexible cords shall be so connected to devices and to fittings that tension is not transmitted to joints or terminal screws. This shall be accomplished by a knot in the cord, by winding with tape, by a special fitting designed for that purpose, or by other approved means which can prevent a pull on the cord from being directly transmitted to joints or terminal screws.

6.7 Passing Through Walls and Floors

6.7.1 Where wires/cables are required to pass through walls, care shall be taken to see that wires/cables pass freely through protective pipe or box and that the wires pass through in a straight line without any twist or cross in wires.

One of the following methods shall be employed for laying wires/cables:

- a) *Conduit wiring system (see 6.10)* — The conductor shall be carried either in a rigid steel conduit or a rigid non-metallic conduit conforming to accepted standards [8-2(33)]. The conduits shall be colour coded as per the purpose of wire carried in the same. The recommended colour coding may be in form of bands of colour (100 mm thick, with centre to centre distance of 300 mm) or coloured throughout. The colour scheme may be as follows:

<i>Conduit Type</i>	<i>Colour Scheme</i>
Power conduit	Black
Security conduit	Blue
Fire alarm conduit	Red
Low voltage conduit	Brown
UPS conduit	Green

Conduit wiring system shall comply with accepted standards [8-2(34)]. The number of insulated conductors that can be drawn into rigid conduit is given in Tables 1 (see Table 1A for rigid steel conduits and Table 1B for rigid non-metallic conduits).

- b) *Cable trunking/cable ways (see 6.11)* — Cable trunking/cable ways system should be used when number of wires/small cable sizes to be laid is more than the conduit capacity. Care should be taken to have space in the trunking system to minimize heating of wires and to provide identification of the different circuits. Cable trunking or ducting system shall comply with accepted standards [8-2(35)].

- c) *Tray and ladder rack* — As tray provides continuous support, unless mounted on edge or in vertical runs (when adequate strapping or clipping is essential), the mechanical strength of supported cable is not as important as with ladder-racking or structural support methods. Consequently, tray is eminently suitable for the smaller unarmoured cabling while ladder racks call for armoured cables or larger unarmoured cables as they provide the necessary strength to avoid sagging between supports. Both tray and ladder racks are provided with accessories to facilitate changes of route, and they provide no difficulty in this respect on vertical runs.

Cable tray/ladder racks and support systems shall be installed in such a way that the deflection between the spans shall be less than 1 percent of the span.

Power cables running in cable ladders both horizontal and vertical shall be fixed with proper clamps which can withstand the mechanical force created on the cable in case of short circuit current. The complete installation consisting of cables, ladders, clamps, ladder supports and fixtures shall also withstand the mechanical force of short circuit current. Only one layer of power cable shall be laid in a ladder. The minimum space between two cables shall be equal to the diameter of the biggest cable.

Cable tray and ladder system shall comply with IEC 61537:2006 ‘Cable management — Cable tray systems and cable ladder systems’ (under publication as an adopted Indian Standard).

6.7.2 Insulated conductors while passing through floors shall be protected from mechanical injury by means of rigid steel/non-metal conduit or by mechanical protection up to a height not less than 1.5 m above the

floor and flush with the ceiling below. These steel conduits shall be earthed and securely bushed.

Power outlets and wiring in the floor shall be generally avoided. If not avoidable, false floor trunking or metal floor trunking should be used. Power sockets of adequate IP/IK rating shall be used.

False floor shall be provided where density of equipment and interconnection between different pieces of equipment is high. Examples are, mainframe computer station, telecommunication switch rooms, etc. Floor trunking shall be used in large halls, convention centres, open plan offices, laboratory, etc.

In case of floor trunking, drain points/weep holes shall be provided within the trunking for installation for conventional centres, exhibition areas or any other place where water may spill into the trunking, as there might be possibility of water seepage in the case of wiring passing through the floors. Proper care should be taken for providing suitable means of draining of water. Possibility of water entry exists from floor washing, condensation in some particular weather and indoor temperature conditions. At the design stage, these aspects shall be assessed and an appropriate means of avoiding, or reducing, and draining method shall be built in. Floor trunking outlets shall be suitably IP rated for protection against dust and water.

Floor outlet boxes are generally provided for the use of appliances, which require a signal, or communication connection. The floor box and trunking system should cater to serve both power distribution and the signal distribution, with appropriate safety and non-interference.

6.7.3 Where a wall tube passes outside a building so as to be exposed to weather, the outer end shall be bell-mouthed and turned downwards and properly bushed on the open end.

6.8 Wiring of Distribution Boards

6.8.1 All connections between pieces of apparatus or between apparatus and terminals on a board shall be neatly arranged in a definite sequence, following the arrangements of the apparatus mounted thereon, avoiding unnecessary crossings.

6.8.2 Cables shall be connected to a terminal only by soldered or welded or crimped lugs using suitable sleeve, lugs or ferrules unless the terminal is of such a form that it is possible to securely clamp them without the cutting away of cables stands. Cables in each circuit shall be bunched together.

6.8.3 All bare conductors shall be rigidly fixed in such a manner that a clearance of at least 25 mm is maintained between conductors or opposite polarity or

phase and between the conductors and any material other than insulation material.

6.8.4 If required, a pilot lamp shall be fixed and connected through an independent single pole switch and fuse to the bus-bars of the board. Leads connecting bus-bars to any instrument or indicating lamp or an outgoing connection switch or breaker face the same fault current that is applicable to the bus-bar and as such should be provided with a fuse capable of handling the prospective fault current.

6.8.5 In a hinged type board, the incoming and outgoing cables shall be fixed at one or more points according to the number of cables on the back of the board leaving suitable space in between cables, and shall also, if possible, be fixed at the corresponding points on the switchboard panel. The cables between these points shall be of such length as to allow the switchboard panel to swing through an angle of not less than 90° and cables arranged and clamped in such a manner that the cables do not face bending, but only face a twist, when the hinged door is opened. The circuit breakers in such cases shall be accessible without opening the door of distribution board. Also, circuit breakers or any other equipment (having cable size more than 1.5 mm² multi-strand wire) shall not be mounted on the door.

NOTE — Use of hinged type boards is discouraged, as these boards lead to deterioration of the cables in the hinged portion, leading to failures or even fire.

6.8.6 Wires terminating and originating from the protective devices shall be properly lugged and taped.

6.9 PVC-Sheathed Wiring System

6.9.1 General

Wiring with PVC-sheathed cables may be used for temporary installations for medium voltage installation and may be installed directly under exposed conditions of sun and rain or damp places.

6.9.2 PVC Clamps/PVC Channel

The clamps shall be used for temporary installations of 1-3 sheathed wires only. The clamps shall be fixed on wall at intervals of 100 mm in the case of horizontal runs and 150 mm in the case of vertical runs.

PVC channel shall be used for temporary installations in case more than 3 wires or wires or unsheathed wires. The channel shall be clamped on wall at intervals not exceeding 300 mm. PVC clamps/PVC channel shall conform to accepted standards.

6.9.3 Protection of PVC-Sheathed Wiring from Mechanical Damage

- a) In cases where there are chances of any damage to the wirings, such wirings shall be

covered with sheet metal protective covering, the base of which is made flush with the plaster or brickwork, as the case may be, or the wiring shall be drawn through a conduit complying with all requirements of conduit wiring system (see 6.10).

- b) Such protective coverings shall in all cases be fitted on all down-drops within 1.5 m from the floor.

6.9.4 Bends in Wiring

The wiring shall not in any circumstances be bent so as to form a right angle but shall be rounded off at the corners to a radius not less than six times the overall diameter of the cable.

6.9.5 Passing Through Floors

All cables taken through floors shall be enclosed in an insulated heavy gauge steel conduit extending 1.5 m above the floor and flush with the ceiling below, or by means of any other approved type of metallic covering. The ends of all conduits or pipes shall be neatly bushed with porcelain, wood or other approved material.

6.9.6 Passing Through Walls

The method to be adopted shall be according to good practice. There shall be one or more conduits of adequate size to carry the conductors [see 6.10.1(a)]. The conduits shall be neatly arranged so that the cables enter them straight without bending.

6.9.7 Stripping of Outer Covering

While cutting and stripping of the outer covering of the cables, care shall be taken that the sharp edge of the cutting instrument does not touch the rubber or PVC-sheathed insulation of conductors. The protective outer covering of the cables shall be stripped off near connecting terminals, and this protective covering shall be maintained up to the close proximity of connecting terminals as far as practicable. Care shall be taken to avoid hammering on link clips with any metal instruments, after the cables are laid. Where junction boxes are provided, they shall be made moisture-proof with an approved plastic compound.

6.9.8 Painting

If so required, the tough rubber-sheathed wiring shall, after erection, be painted with one coat of oil-less paint or distemper of suitable colour over a coat of oil-less primer, and the PVC-sheathed wiring shall be painted with a synthetic enamel paint of quick drying type.

6.10 Conduit Wiring System

Conduit wiring system shall comply with accepted standards [8-2(34)]. Requirements relating to conduit

wiring system with rigid steel and non-metallic conduits shall be as per 6.10.1 to 6.10.3.

6.10.1 Surface Conduit Wiring System with Rigid Steel Conduits

- a) *Type and size of conduit* — All conduit pipes shall conform to accepted standards [8-2(36)], finished with galvanized or enamelled surface. All conduit accessories shall be of threaded type and under no circumstance pin grip type or clamp type accessories be used. No steel conduit less than 16 mm in diameter shall be used. The number of insulated conductors that can be drawn into rigid steel conduit is given in Tables 1A.
- b) *Bunching of cables* — Unless otherwise specified, insulated conductors of a.c. supply and d.c. supply shall be bunched in separate conduits. For lighting and small power outlet circuits phase segregation in separate conduits is recommended.
- c) *Conduit joints* — Conduit pipes shall be joined by means of screwed couplers and screwed accessories only [see 8-2(37)]. In long distance straight runs of conduit, inspection type couplers at reasonable intervals shall be provided or running threads with couplers and jam-nuts (in the latter case the bare threaded portion shall be treated with anti-corrosive preservative) shall be provided. Threaded on conduit pipes in all cases shall be between 11 mm and 27 mm long sufficient to accommodate pipes to full threaded portion of couplers or accessories. Cut ends of conduit pipes shall have no sharp edges or any burrs left to avoid damage to the insulation of conductors while pulling them through such pipes.
- d) *Protection against dampness* — In order to minimize condensation or sweating inside the tube, all outlets of conduit system shall be properly drained and ventilated, but in such a manner as to prevent the entry of insects as far as possible.
- e) *Protection of conduit against rust* — The outer surface of the conduit pipes, including all bends, unions, tees, conduit system shall be adequately protected against rust particularly when such system is exposed to weather. In all cases, no bare threaded portion of conduit pipe shall be allowed unless such bare threaded portion is treated with anti-corrosive preservative or covered with suitable plastic compound.
- f) *Fixing of conduit* — Conduit pipes shall be fixed by heavy gauge saddles, secured to

Table 1A Maximum Permissible Number of Single-Core Cables up to and including 1 100 V that can be Drawn into Rigid Steel Conduits
 [Clauses 6.7.1(a) and 6.10.1(a)]

Sl No.	Size of Cable		Size of Conduit mm													
	Nominal Cross-Sectional Area mm ²	Number and Diameter (in mm) of Wires	Number of Cables, Max													
			16		20		25		32		40		50		63	
(1)	(2)	(3)	S	B	S	B	S	B	S	B	S	B	S	B	S	B
i)	1.0	1/1.12 ¹⁾	5	4	7	5	13	10	20	14	—	—	—	—	—	—
ii)	1.5	1/1.40	4	3	7	5	12	10	20	14	—	—	—	—	—	—
iii)	2.5	1/1.80	3	2	6	5	10	8	18	12	—	—	—	—	—	—
		3/1.06 ¹⁾														
iv)	4	1/2.24	3	2	4	3	7	5	12	10	—	—	—	—	—	—
		7/0.85 ¹⁾														
v)	6	1/2.80	2	—	3	2	6	5	10	8	—	—	—	—	—	—
		7/1.06 ¹⁾														
vi)	10	1/3.55 ²⁾	—	—	2	—	5	4	8	7	—	—	—	—	—	—
		7/1.40 ¹⁾														
vii)	16	7/1.70	—	—	—	—	2	—	4	3	7	6	—	—	—	—
viii)	25	7/2.24	—	—	—	—	—	—	3	2	5	4	8	6	9	7
ix)	35	7/2.50	—	—	—	—	—	—	2	—	4	3	7	5	8	6
x)	50	19/1.80	—	—	—	—	—	—	—	—	2	—	5	4	6	5
		7/3.007 ²⁾														

NOTES

1 The table shows the maximum capacity of conduits for the simultaneously drawing of cables. The columns headed S apply to runs of conduit which have distance not exceeding 4.25 m between draw-in boxes, and which do not deflect from the straight by an angle of more than 15°. The columns headed B apply to runs of conduit which deflect from the straight by an angle of more than 15°.

2 In case an inspection type draw-in box has been provided and if the cable is first drawn through one straight conduit, then through the draw-in box, and then through the second straight conduit, such systems may be considered as that of a straight conduit even if the conduit deflects through the straight by more than 15°.

3 Conductor sizes for cables and wires above and including 2.5 mm² core size shall be multi-stranded.

¹⁾ For copper conductors only.

²⁾ For aluminium conductors only.

suitable wood plugs or other plugs with screws in an approved manner at an interval of not more than 1 m, but on either side of couplers or bends or similar fittings, saddles shall be fixed at a distance of 300 mm from the centre of such fittings. Conduit fittings shall be avoided as far as possible on conduit system exposed to weather; where necessary, solid type fittings shall be used.

- g) *Bends in conduit* — All necessary bends in the system including diversion shall be done by bending pipes; or by inserting suitable solid or inspection type normal bends, elbows or similar fittings; or fixing cast iron, thermoplastic or thermosetting plastic material inspection boxes, whichever is more suitable. Radius of such bends in conduit pipes shall be not less than 75 mm. No length of conduit shall have more than the equivalent of four quarter bends from outlet to outlet, the bends at the outlets not being counted.

- h) *Outlets* — All outlets for fittings, switches, etc, shall be boxes of suitable metal or any other approved outlet boxes for either surface mounting or flush mounting system.

- j) *Conductors* — All conductors used in conduit wiring shall preferably be stranded. No single-core cable of nominal cross-sectional area greater than 130 mm² enclosed along in a conduit and used for alternating current.

- k) *Erection and earthing of conduit* — The conduit of each circuit or section shall be completed before conductors are drawn in. The entire system of conduit after erection shall be tested for mechanical and electrical continuity throughout and permanently connected to earth conforming to the requirements as already specified by means of suitable earthing clamp efficiently fastened to conduit pipe in a workman like manner for a perfect continuity between each wire and conduit. Gas or water pipes shall not be used

as earth medium. If conduit pipes are liable to mechanical damage they shall be adequately protected.

- m) Inspection type conduit fittings, such as inspection boxes, draw boxes, bends, elbows and tees shall be so installed that they can remain accessible for such purposes as to withdrawal of existing cables or the installing of traditional cables.

6.10.2 Recessed Conduit Wiring System with Rigid Steel Conduit

Recessed conduit wiring system shall comply with all the requirements for surface conduit wiring system specified in 6.10.1 (a) to 6.10.1 (k) and in addition, conform to the requirements specified below:

- a) *Making of chase* — The chase in the wall shall be neatly made and be of ample dimensions to permit the conduit to be fixed in the manner desired. In the case of buildings under construction, chases shall be provided in the wall, ceiling, etc, at the time of their construction and shall be filled up neatly after erection of conduit and brought to the original finish of the wall. In case of exposed brick/rubble masonry work, special care shall be taken to fix the conduit and accessories in position along with the building work.
- b) *Fixing of conduit in chase* — The conduit pipe shall be fixed by means of staples or by means of saddles not more than 600 mm apart. Fixing of standard bends or elbows shall be avoided as far as practicable and all curves maintained by bending the conduit pipe itself with a long radius which will permit easy drawing-in of conductors. All threaded joints of rigid steel conduit shall be treated with preservative compound to secure protection against rust.
- c) *Inspection boxes* — Suitable inspection boxes shall be provided to permit periodical inspection and to facilitate removal of wires, if necessary. These shall be mounted flush with the wall. Suitable ventilating holes shall be provided in the inspection box covers. The minimum sizes of inspection boxes shall be 75 mm × 75 mm.
- d) *Types of accessories to be used* — All outlet, such as switches and wall sockets, may be either of flush mounting type or of surface mounting type, as given below:
- 1) *Flush mounting type* — All flush mounting outlets shall be of cast-iron or mild steel boxes with a cover of insulating material or shall be a box made of a suitable insulating material. The switches

and other outlets shall be mounted on such boxes. The metal box shall be efficiently earthed with conduit by a suitable means of earth attachment.

- 2) *Surface mounting type* — If surface mounting type outlet box is specified, it shall be of any suitable insulating material and outlets mounted in an approved manner.

The switches/socket outlets shall have adequate IP rating for various utilizations.

6.10.3 Conduit Wiring System with Rigid Non-Metallic Conduits

Rigid non-metallic conduits are used for concealed conduit wiring.

6.10.3.1 Type and size

All non-metallic conduits used shall conform to accepted standards [8-2(38)] and shall be used with the corresponding accessories {see accepted standards [8-2(39)]}. The conduits shall be circular or rectangular cross-sections.

6.10.3.2 Bunching of cables

Conductors of a.c. supply and d.c. supply shall be bunched in separate conduits. For lighting and small power outlet circuits phase segregation in separate circuits is recommended. The number of insulated cables that may be drawn into the conduits are given in Table 1B. In Table 1B, the space factor does not exceed 40 percent.

6.10.3.3 Conduit Joints

Conduits shall be joined by means of couplers. Where there are long runs of straight conduit, inspection type couplers shall be provided at intervals. For conduit fittings and accessories reference may be made to the good practice [8-2(39)].

6.10.3.4 Fixing of conduit in chase

The conduit pipe shall be fixed by means of staples or by means of non-metallic saddles placed at not more than 800 mm apart or by any other approved means of fixing. Fixing of standard bends or elbows shall be avoided as far as practicable and all curves shall be maintained by bending the conduit pipe itself with a long radius which will permit easy drawing in of conductors. At either side of bends, saddles/staples shall be fixed at a distance of 150 mm from the centre of bends.

6.10.3.5 Inspection boxes

Suitable inspection boxes to the nearest minimum requirements shall be provided to permit periodical inspection and to facilitate replacement of wires, if

Table 1B Maximum Permissible Number of 250 V Grade Single-Core Cables that may be Drawn into Rigid Non-Metallic Conduits
 [Clauses 6.7.1(a) and 6.10.3.2]

Sl No.	Sizes of Cable		Size of Conduit mm					
	Nominal Cross-Sectional Area mm ²	Number and Diameter (in mm) of Wires	16	20	25	32	40	50
(1)	(2)	(3)	(4)	(5)	(6)	(7)	(8)	(9)
i)	1.0	1/1.12 ¹⁾	5	7	13	20	—	—
ii)	1.5	1/1.40	4	6	10	14	—	—
iii)	2.5	(1/1.80) [3/1.06 ¹⁾	3	5	10	14	—	—
iv)	4	(1/2.24) [7/0.85 ¹⁾	2	3	6	10	14	—
v)	6	(1/2.80) [7/1.40 ¹⁾	—	2	5	9	11	—
vi)	10	[1/3.55 ²⁾ [7/1.40 ¹⁾	—	—	4	7	9	—
vii)	16	7/1.70	—	—	2	4	5	12
viii)	25	7/2.24	—	—	—	2	2	6
ix)	35	7/2.50	—	—	—	—	2	5
x)	50	7/3.00 ²⁾ 19/1.80	—	—	—	—	2	5
			—	—	—	—	2	3

¹⁾ For copper conductors only.

²⁾ For aluminium conductors only.

necessary. The inspection/junction boxes shall be mounted flush with the wall or ceiling concrete. Where necessary deeper boxes of suitable dimensions shall be used. Suitable ventilating holes shall be provided in the inspection box covers, where required.

6.10.3.6 The outlet boxes such as switch boxes, regulator boxes and their phenolic laminated sheet covers shall be as per requirements of 6.10.1 (h). They shall be mounted flush with the wall.

6.10.3.7 *Types of accessories to be used*

All accessories such as switches, wall sockets, etc, may be either flush mounting type or of surface mounting type.

6.10.3.8 *Bends in conduits*

Wherever necessary, bends or diversions may be achieved by bending the conduits or by employing normal bends, inspection bends, inspection boxes, elbows or similar fittings. Heat may be used to soften the conduit for bending and forming joints in case of plain conduits.

6.10.3.9 *Outlets*

In order to minimize condensation or sweating inside the conduit, all outlets of conduit system shall be properly drained and ventilated, but in such a manner as to prevent the entry of insects.

6.11 *Cable Trunking/Cable Ways*

Cable trunking and ducting system of insulating

material are used for surface wiring. The number of insulated conductors that can be drawn into cable trunking and ducting system are given in Table 2.

7 FITTINGS AND ACCESSORIES

7.1 Ceiling Roses and Similar Attachments

7.1.1 A ceiling rose or any other similar attachment shall not be used on a circuit the voltage of which normally exceeds 250 V.

7.1.2 Normally, only one flexible cord shall be attached to a ceiling rose. Specially designed ceiling roses shall be used for multiple pendants.

7.1.3 A ceiling rose shall not embody fuse terminal as an integral part of it.

7.2 Socket-Outlets and Plugs

Each 16 A socket-outlet provided in buildings for the use of domestic appliances, such as, air conditioner and water cooler shall be provided with its own individual fuse, with suitable discrimination with back-up fuse or miniature circuit-breaker provided in the distribution/sub-distribution board. The socket-outlet shall not necessarily embody the fuse as an integral part of it.

7.2.1 Each socket-outlet shall also be controlled by a switch which shall preferably be located immediately adjacent thereto or combined therewith.

7.2.2 The switch controlling the socket-outlet shall be on the live side of the line.

Table 2 Maximum Permissible Number of PVC Insulated 650/1 100 V Grade Aluminium/Copper Cable Conforming to Accepted Standard [8-2(3)] that can be Drawn into Cable Trunking/Cable Ways (Clause 6.11)

Sl No.	Nominal Cross-Sectional Area of Conductor mm ²	10/15 mm × 10 mm	20/15 mm × 10 mm	25/15 mm × 16 mm	32 mm × 16 mm	40 mm × 25 mm	40 mm × 40 mm
(1)	(2)	(3)	(4)	(5)	(6)	(7)	(8)
i)	1.5	3	5	6	8	12	18
ii)	2.5	2	4	5	6	9	15
iii)	4	2	3	4	5	8	12
iv)	6	—	2	3	4	6	9
v)	10	—	1	2	3	5	8
vi)	16	—	—	1	2	4	6
vii)	25	—	—	—	1	3	5
viii)	35	—	—	—	—	2	4
ix)	50	—	—	—	—	1	3
x)	70	—	—	—	—	1	2

7.2.3 Ordinary socket-outlet may be fixed at any convenient place at a height above 200 mm from the floor level and shall be away from danger of mechanical injury.

NOTE — In situations where a socket-outlet is accessible to children, it is necessary to install an interlocked plug and socket or alternatively a socket-outlet which automatically gets screened by the withdrawal of plug. In industrial premises socket-outlet of rating 20 A and above shall preferably be provided with interlocked type switch.

In case of public buildings, to facilitate operation of switches/socket-outlets by persons with disabilities and the elderly, these shall be installed at an accessible height for reaching and operating, between 800 mm and 1 100 mm above floor level and shall be located at a minimum of 600 mm with a preference of minimum 700 mm, from any internal corner (*see also B-7* of Part 3 ‘Development Control Rules and General Building Requirements’ of the Code). They shall be so fixed so as to be away from danger of mechanical injury.

NOTE — As an exception, electrical wall socket outlets, telephone points and TV sockets can be located at a minimum height of 400 mm above floor level.

7.2.4 In an earthed system of supply, a socket-outlet with plug shall be of three-pin or five-pin type with the third or fifth terminal connected to the earth. When such socket-outlets with plugs are connected to any current consuming device of metal or any non-insulating material or both, conductors connecting such current-consuming devices shall be of flexible cord with an earthing core and the earthing core shall be secured by connecting between the earth terminal of plug and the body of current-consuming devices.

In industrial premises three-phase and neutral socket-outlets shall be provided with a earth terminal either of

pin type or scrapping type in addition to the main pins required for the purpose.

7.2.5 In wiring installations for residential buildings, metal clad switch, socket-outlet and plugs shall be used for power wiring. For industrial and commercial application socket outlets conforming to accepted standards [8-2(25)] with suitable circuit breakers shall be used.

NOTE — A recommended schedule of socket-outlets in a residential building is given below:

Sl No.	Location	Number of 6 A Socket-Outlets	Number of 16 A Socket-Outlets
(1)	(2)	(3)	(4)
i)	Bed room	2 to 6	2
ii)	Living room	2 to 4	2
iii)	Kitchen	2 to 8	2
iv)	Dining room	2 to 4	2
v)	Garage	1	1
vi)	For refrigerator	—	1
vii)	For air conditioner	—	1 for each
viii)	Verandah	1 per 10 m ²	1
ix)	Bathroom	1	1

7.3 Lighting Fittings

7.3.1 A switch shall be provided for control of every lighting fitting or a group of lighting fittings. Where control at more than one point is necessary as many two way or intermediate switches may be provided as there are control points. *See also 7.2.3.*

7.3.2 In industrial premises, lighting fittings shall be supported by suitable pipe/conduits, brackets fabricated from structural steel, steel chains or similar materials depending upon the type and weight of the fittings.

Where a lighting fitting is supported by one or more flexible cords, the maximum weight to which the twin flexible cords may be subjected shall be as follows:

<i>Sl No.</i>	<i>Nominal Cross-Sectional Area of Twin Cord</i> mm ²	<i>Maximum Permissible Weight</i> kg
(1)	(2)	(3)
i)	0.5	2
ii)	0.75	3
iii)	1.0	5
iv)	1.5	5.3
v)	2.5	8.8
vi)	4	14.0

7.3.3 No flammable shade shall form a part of lighting fittings unless such shade is well protected against all risks of fire. Celluloid shade or lighting fittings shall not be used under any circumstances.

7.3.4 General and safety requirements for electrical lighting fittings shall be in accordance with good practice [8-2(40)].

7.3.5 The lighting fittings shall conform to accepted standards [8-2(26)].

7.4 Fitting-Wire

The use of fitting-wire shall be restricted to the internal wiring of the lighting fittings. Where fitting-wire is used for wiring fittings, the sub-circuit loads shall terminate in a ceiling rose or box with connectors from which they shall be carried into the fittings.

7.5 Lampholders

Lampholders for use on brackets and the like shall be in accordance with accepted standards [8-2(41)] and all those for use with flexible pendants shall be provided with cord grips. All lampholders shall be provided with shade carriers. Where centre-contact Edison screw lampholders are used, the outer or screw contacts shall be connected to the ‘middle wire’, the neutral, the earthed conductor of the circuit.

7.6 Outdoor Lamps

External and road lamps shall have weatherproof fittings of approved design so as to effectively prevent the ingress of moisture and dust. Flexible cord and cord grip lampholders shall not be used where exposed to weather. In verandahs and similar exposed situations where pendants are used, these shall be of fixed rod type.

7.7 Lamps

All lamps unless otherwise required and suitably protected, shall be hung at a height of not less than

2.5 m above the floor level. All electric lamps and accessories shall conform to accepted standards [8-2(42)]. Following shall also be ensured:

- a) Portable lamps shall be wired with flexible cord. Hand lamps shall be equipped with a handle of moulded composition or other material approved for the purpose. Hand lamps shall be equipped with a substantial guard attached to the lampholder or handle. Metallic guards shall be earthed suitably.
- b) A bushing or the equivalent shall be provided where flexible cord enters the base or stem of portable lamp. The bushing shall be of insulating material unless a jacketed type of cord is used.
- c) All wiring shall be free from short circuits and shall be tested for these defects prior to being connected to the circuit.
- d) Exposed live parts within porcelain fixtures shall be suitably recessed and so located as to make it improbable that wires will come in contact with them. There shall be a spacing of at least 125 mm between live parts and the mounting plane of the fixture.

7.8 Fans, Regulators and Clamps

7.8.1 Ceiling Fans

Ceiling fans including their suspension shall conform to accepted standards [8-2(43)] and to the following requirements:

- a) Control of a ceiling fan shall be through its own regulator as well as a switch in series. *See also 7.2.3.*
- b) All ceiling fans shall be wired with normal wiring to ceiling roses or to special connector boxes to which fan rod wires shall be connected and suspended from hooks or shackles with insulators between hooks and suspension rods. There shall be no joint in the suspension rod, but if joints are unavoidable then such joints shall be screwed to special couplers of 50 mm minimum length and both ends of the pipes shall touch together within the couplers, and shall in addition be secured by means of split pins; alternatively, the two pipes may be welded. The suspension rod shall be of adequate strength to withstand the dead and impact forces imposed on it. Suspension rods should preferably be procured along with the fan.
- c) Fan clamps shall be of suitable design according to the nature of construction of ceiling on which these clamps are to be fitted. In all cases fan clamps shall be fabricated from new metal of suitable sizes and they shall be

as close fitting as possible. Fan clamps for reinforced concrete roofs shall be buried with the casting and due care shall be taken that they shall serve the purpose. Fan clamps for wooden beams, shall be of suitable flat iron fixed on two sides of the beam and according to the size and section of the beam one or two mild steel bolts passing through the beam shall hold both flat irons together. Fan clamps for steel joist shall be fabricated from flat iron to fit rigidly to the bottom flange of the beam. Care shall be taken during fabrication that the metal does not crack while hammer to shape. Other fan clamps shall be made to suit the position, but in all cases care shall be taken to see that they are rigid and safe.

- d) Canopies on top and bottom of suspension rods shall effectively conceal suspensions and connections to fan motors, respectively.
- e) The lead-in-wire shall be of nominal cross-sectional area not less than 1.5 mm² copper and shall be protected from abrasion.
- f) Unless otherwise specified, the clearance between the bottom most point of the ceiling fan and the floor shall be not less than 2.4 m. The minimum clearance between the ceiling and the plane of the blades shall be not less than 300 mm.

A typical arrangement of a fan clamp is given in Fig. 4.

NOTE — All fan clamps shall be so fabricated that fans revolve steadily.

7.8.2 Exhaust Fans

For fixing of an exhaust fan, a circular hole shall be provided in the wall to suit the size of the frame which shall be fixed by means of rag-bolts embedded in the wall. The hole shall be nearly plastered with cement and brought to the original finish of the wall. The exhaust fan shall be connected to exhaust fan point which shall be wired as near to the hole as possible by means of a flexible cord, care being taken that the blades rotate in the proper direction.

7.8.3 Fannage

7.8.3.1 Where ceiling fans are provided, the bay sizes of a building, which control fan point locations, play an important part. Fans of 1 200/1 400 mm sweep normally cover an area of 9 m² to 10 m² and therefore in general purpose office buildings, for every part of a bay to be served by the ceiling fans, it is necessary that the bays shall be so designed that full number of fans can be suitably located for the bay, otherwise it will result in ill-ventilated pockets. In general, fans in long halls may be spaced at 3 m in both the directions. If building modules do not lend themselves for proper

positioning of the required number of ceiling fans, other fans such as, air circulators or bracket fans will have to be employed for the areas uncovered by the ceiling fans. For this, suitable electrical outlets shall be provided although result will be disproportionate to cost on account of fans.

7.8.3.2 Proper air circulation may be achieved either by larger number of smaller fans or smaller number of larger fans. The economics of the system as a whole should be a guiding factor in choosing the number and type of fans and their locations. For design guidelines in this regard, reference shall be made to Part 8 'Building Services, Section 1 Lighting and Natural Ventilation' of the Code.

7.8.3.3 Exhaust fans are necessary for spaces, such as community toilets, kitchens and canteens, and godowns to provide the required number of air changes (*see* Part 8 'Building Services, Section 3 Air Conditioning, Heating and Mechanical Ventilation' of the Code). Since the exhaust fans are located generally on the outer walls of a room, appropriate openings in such walls shall be provided for, in the planning stage.

NOTE — Exhaust fan requirement is based on the recommended air changes (*see* Part 8 'Building Services, Section 3 Air Conditioning, Heating and Mechanical Ventilation' of the Code). Reference shall also be made to Part 4 'Fire and Life Safety' of the Code for exhaust fan requirements for smoke extraction.

7.9 Attachment of Fittings and Accessories

7.9.1 In wiring other than conduit wiring, all ceiling roses, brackets, pendants and accessories attached to walls or ceilings shall be mounted on substantial teak wood blocks twice varnished after all fixing holes are made in them. Blocks shall not be less than 40 mm deep. Brass screws shall only be used for attaching fittings and accessories to their base blocks.

7.9.2 Where teak or hardwood boards are used for mounting switches, regulators, etc, these boards shall be well varnished with pure shellac on all four sides (both inside and outside), irrespective of being painted to match the surroundings. The size of such boards shall depend on the number of accessories that can be conveniently and neatly be arranged. Where there is danger of attack by white ants, the boards shall be treated with suitable anti-termite compound and painted on both sides.

7.10 Interchangeability

Similar parts of all switches, lamp holders, distribution fuse-boards, ceiling roses, brackets, pendants, fans and all other fittings shall be so chosen that they are of the same type and interchangeable in each installation.

7.11 Equipment

Electrical equipment which form integral part of wiring

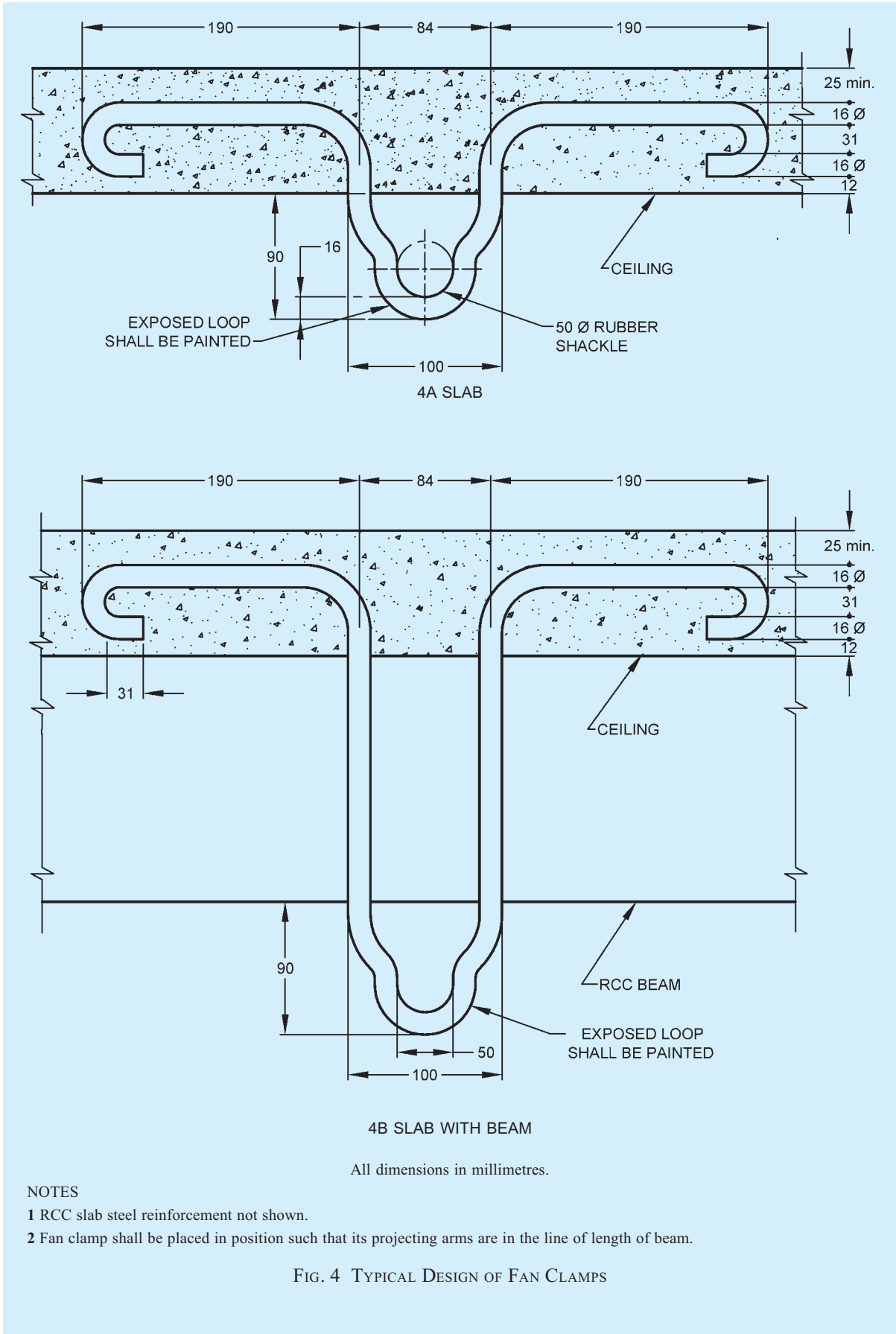

intended for switching or control or protection of wiring installations shall conform to the relevant Indian Standards, wherever they exist.

7.12 Positioning of fans and light fittings shall be chosen to make these effective without causing shadows and stroboscopic effect on the working planes.

8 EARTHING

8.1 General

8.1.1 Earthing is an essential part of any electrical installation, essential for the safety from electrical shock, and fire and for operation of most of the protective systems of the electrical installation. The earthing provides the necessary reference of zero potential and helps in activating the operation of the circuit breaker provided for the safe disconnection of power in the event of an abnormality in the flow of current. Earthing systems, apart from addressing safety from shock and fire, help in limiting the interference between one appliance and the other. This is of particular importance in the case of voice and data communication devices. With the proliferation in electrical/electronic gadgets and greater dependence on voice and data communication systems, proper and effective earthing or grounding is very important. Earthing is also necessary for diverting the effects of lightning strikes from the buildings and its contents, including from sensitive equipment.

8.1.2 Different types of earth electrodes and different types of earthing systems available. For low voltage and medium voltage systems which apply to almost all electrical systems of buildings, the common earthing system followed is with the neutral solidly earthed at the source. This system requires that there is always a protective earth continuity conductor running all through the system and all metal parts of electrical appliances connected to an electrical system are connected to the earth continuity conductor. The exception to this system is the double insulated appliances which are connected to the line and neutral and operate on low voltage (single phase) and are also of low power consumption. All appliances (other than double insulated devices) use the earthing through the earth continuity conductor. Single phase appliances use a 3-wire connection with line (live wire), neutral (return path wire) and the earth-wire at zero potential. Three phase appliances use a connection with 4-wires for a load which does not require a neutral connection or use a 5-wire connection if the appliance requires a neutral connection. Care should be taken to ensure that the earthing system, the earth continuity conductor and in case of sockets the earthing pin are not disconnected.

8.1.3 Different earthing systems have features which are suitable for different applications. Earthing system

adopted should be so selected so as to match with the type of load, protection device, application, degree of reliability, etc. For classification of electrical systems based on the relationship of the source, and of exposed-conductive parts of the installation, to earth, *see* **2.1.75**.

8.2 Selection and Design of Earthing System

8.2.1 Earthing shall generally be carried out in accordance with the requirements of Regulation 16, 41 and 48 of *Central Electricity Authority (Measures relating to Safety and Electricity Supply) Regulations, 2010* as amended from time-to-time (*see* Annex B) and good practice [8-2(44)] and the relevant regulations of the Electricity Supply Authority concerned.

8.2.2 Conductors and earth electrodes in an earthing system shall be so designed and constructed that in normal use their performance is reliable and without danger to persons and surrounding equipment. Earthing system shall be designed such as to have touch potential and step potential as specified in good practice [8-2(44)]. The choice of a material depends on its ability to match the particular application requirement. The requirements for earthing arrangements are intended to provide a connection to earth which,

- a) is reliable and suitable for the protective requirements of the installation;
- b) can carry earth fault currents and protective conductor currents to earth without danger from thermal, thermo-mechanical and electromechanical stresses and from electric shock arising from these currents;
- c) if relevant, is also suitable for functional requirements; and
- d) is suitable for the foreseeable external influences {*see* good practice [8-2(44)] and IEC 60364-5-51:2005 'Electrical installations of buildings — Part 5-51: Selection and erection of electrical equipment — Common rules'}, for example, mechanical stresses and corrosion.

8.2.3 The main earthing system of an electrical installation shall consist of,

- a) an earth electrode, (electrode can be one vertical rod/pipe/buried plate or an earth mat with several vertical installations or a ring earthing with vertical installations.
- b) a main earthing wire;
- c) an earth bar (located on the main switchboard for small installation and installed in the wall/room in case of large industrial electronic installations) for the connection of the main earthing wire, protective earthing wires and/or bonding wires within the installation; and

- d) a removable link, which effectively disconnects the neutral bar from the earth bar.

NOTE — The requirements of (c) and (d) shall be carried out by a licensed electrician as part of the switchboard installation.

8.2.4 The main earthing wire connection shall,

- a) be mechanically and electrically sound;
- b) be protected against damage, corrosion, and vibration;
- c) not place any strain on various parts of the connection;
- d) not damage the wire or fittings; and
- e) be secured at the earth electrode.

8.2.4.1 The main earthing wire termination shall be readily accessible at the earth electrode except for **8.2.20**. As far as possible, all earth connections, except exothermically welded, shall be visible for inspection.

8.2.5 Consideration shall be given to the earthing arrangements where currents with high frequencies are expected to flow (*see* **444** of IEC 60364-4-44:2007 ‘Low-voltage electrical installations — Part 4-44: Protection for safety — Protection against voltage disturbances and electromagnetic disturbances’).

8.2.6 Protection against electric shock (*see* IEC 60364-4-41 ‘Low-voltage electrical installations — Part 4-41: Protection for safety — Protection against electric shock’), shall not be adversely affected by any foreseeable change of the earth electrode resistance (for example, due to corrosion, drying or freezing).

8.2.7 Where the supply to an installation is at high or extra high voltage, requirements concerning the earthing arrangements of the high or extra high voltage supply and of the low-voltage installation shall also comply with **442** of IEC 60364-4-44:2007 ‘Low-voltage electrical installations — Part 4-44: Protection for safety — Protection against voltage disturbances and electromagnetic disturbances’.

8.2.8 A permanent fitting (like a screwed-down plastic label or copper label, or one that can be threaded onto the cable) shall be used at the connection point that is clearly marked with the words: ‘EARTHING LEAD — DO NOT DISCONNECT’ or ‘EARTHING CONDUCTOR — DO NOT DISCONNECT’.

8.2.9 All medium voltage equipment shall be earthed by two separate and distinct connections with earth. The contact area of earth conductor/plate shall be determined in accordance with good practice [8-2(44)].

8.2.9.1 The 415/240 V, 4-wire, 3-phase systems are normally operated with the neutral solidly earthed at source. At medium voltage, Central Electricity

Authority regulations require that the neutral be earthed by two separate and distinct connections with earth. Source in the case of a substation (such as 11 kV/415 V) will be the neutral(s) of the transformer(s). Neutral conductor shall be of the same size as the phase conductor.

NOTE — Neutral conductor of half the size of the phase conductor was permitted in earlier installations. But with the proliferation of equipment using non-linear devices and consequent increase in harmonics, the neutral will carry a current more than the notional out-of-balance current and therefore neutral conductor shall be of the same size as the phase conductor.

8.2.10 In the case of high and extra high voltages, the neutral points shall be earthed by not less than two separate and distinct connections to earth, each having its own electrode at the generating station or substation and may be earthed at any other point provided no interference is caused by such earthing. The neutral may be earthed through suitable impedance. Neutral earthing conductor shall be sized as to have a current carrying capacity not less than the phase current.

8.2.11 For industrial/commercial installations having a transformer within the facility, soil resistivity of the place of installation shall be measured as per good practice [8-2(44)] and recorded. For the adopted type of earth electrode configuration, earth resistance of each electrode configuration shall be calculated and recorded based on good practice [8-2(44)].

8.2.12 It is recommended that a drawing showing the main earth connection and earth electrodes be prepared for each installation.

8.2.13 Conductors, other than live conductors, and any other parts intended to carry a fault current shall be capable of carrying that current without attaining an excessive temperature.

8.2.14 Earth system shall be so devised that the testing of individual earth electrode is possible {except for installations according to **5.3.6** of good practice [8-2(45)]}. It is recommended that the value of any earth system resistance shall be such as to conform to the degree of shock protection desired. For measuring purposes, the joint shall be capable of being opened with the aid of a tool. In normal use it shall remain closed.

8.2.15 No addition to the current-carrying system, either temporary or permanent, shall be made which will increase the maximum available earth fault current or its duration until it has been ascertained that the existing arrangement of earth electrodes, earth bus-bar, etc, are capable of carrying the new value of earth fault current which may be obtained by this addition.

8.2.16 No cut-out, link or switch other than a linked switch arranged to operate simultaneously on the

earthed or earthed neutral conductor and the live conductors, shall be inserted on any supply system. This, however, does not include the case of a switch for use in controlling a generator or a transformer or a link for test purposes.

8.2.17 All materials, fittings, etc, used in earthing shall conform to relevant Indian Standard specification, wherever these exist.

8.2.18 Earthing associated with current-carrying conductor is normally essential for the function of the system and is generally known as system earthing or functional earthing, while earthing of non-current carrying metal work and conductor is essential for the safety of human life, of animals and of property and it is generally known as equipment earthing or protective earthing. The earthing arrangements may be used jointly or separately for protective and functional purposes according to the requirements of the electrical installation. The requirements for protective purposes shall always take precedence.

8.2.19 For selection of electrodes for use in corrosive environments, reference shall be made to good practice [8-2(44)].

8.2.20 Test joints are not required in the case of natural down-conductors combined with foundation earth electrodes (*see* Fig. 5).

8.2.21 For computer and other sensitive electronic equipment system in industrial and commercial application, special bonding techniques with isolation transformer should be employed (*see* Fig. 6).

8.2.22 Isolated earthing is unsafe during a transient condition. In unavoidable conditions if isolated earthing is used, to reduce potential difference between isolated earthing, earth couplers or isolating spark gaps shall be installed. This will reduce potential difference during a transient condition such as lightning.

8.3 Earth Electrodes

The efficacy of any earth electrode depends on its configuration and upon local soil conditions. Number of earth electrodes suitable for the soil conditions and the value of resistance to earth required shall be considered. Examples of earth electrodes which may be used are,

- a) concrete-embedded foundation earth electrode;
- b) soil-embedded foundation earth electrode;
- c) metallic electrode embedded directly in soil vertically or horizontally (for example rods, wires, tapes, pipes or plates);
- d) metal sheath and other metal coverings of cables according to local conditions or

requirements;

- e) other suitable underground metalwork (for example, pipes) according to local conditions or requirements; and
- f) welded metal reinforcement of concrete (except pre-stressed concrete) embedded in the earth.

The type, materials and dimensions of earth electrodes shall be selected to withstand corrosion and to have adequate mechanical strength for the intended lifetime. For materials commonly used for earth electrodes, the minimum sizes, from the point of view of corrosion and mechanical strength, when embedded in the soil or in concrete, may be as specified in Table 3. If a lightning protection system is required, **11.5.3** applies {*see* 5.4 of good practice [8-2(45)]}.

NOTES

1 For corrosion, the parameters to be considered are: the soil pH at the site, soil resistivity, soil moisture, stray and leakage a.c. and d.c. current, chemical contamination, and proximity of dissimilar materials.

2 The minimum thickness of protective coating is greater for vertical earth electrodes than for horizontal earth electrodes because of their greater exposure to mechanical stresses while being embedded.

Earth electrode either in the form of solid rod, pipe, plate or earth grid should be provided at all premises for providing an earth system. Details of typical pipe, rod and plate earth electrodes are given in Fig. 7 and Fig. 8. Other electrode configurations can be as in Fig. 9 {*see also* 9.2 of good practice [8-2(44)]}.

Although electrode material does not affect initial earth resistance, care should be taken to select a material which is resistant to corrosion in the type of soil in which it is used. In case where soil condition leads to excessive corrosion of the electrode, and the connections, it is recommended to use either copper/stainless steel or copper coated steel electrode and copper/stainless steel connections. Exothermic welding may also be adopted to have enhanced life and strength to the connection (*see* Fig. 7B and Fig. 8B). It is recommended to use similar material for earth electrodes and earth conductors or otherwise precautions should be taken to avoid corrosion.

8.4 Earth Enhancing Compound

Multiple rods, even in large numbers, may sometime fail to produce an adequately low resistance to earth. This condition arises in installations involving soils of high resistivity. The alternative is to reduce the resistivity of the soil immediately surrounding the earth electrode. To reduce the soil resistivity, artificial soil treatment shall be adopted.

8.4.1 Earthing enhancing compound is a conductive

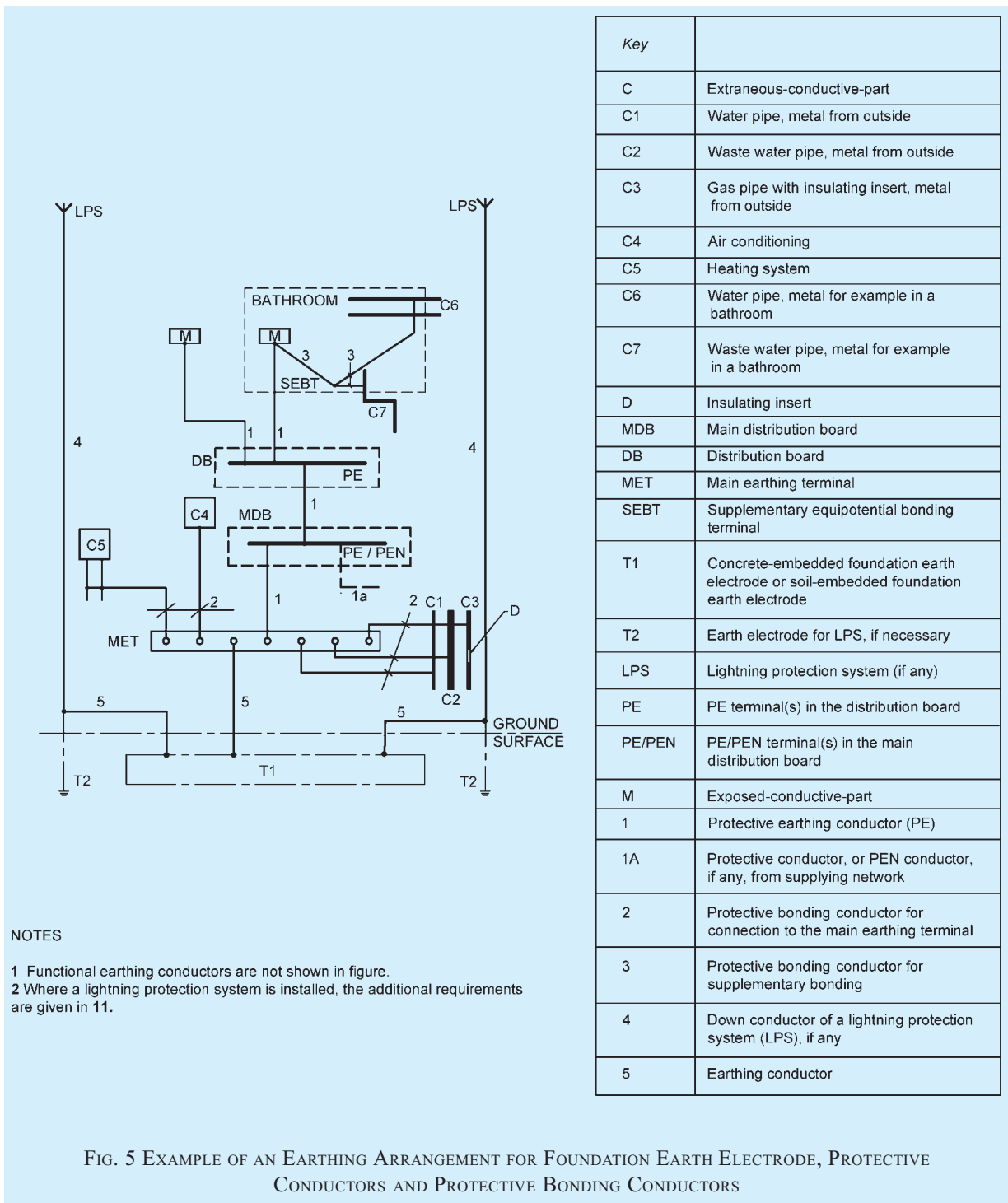

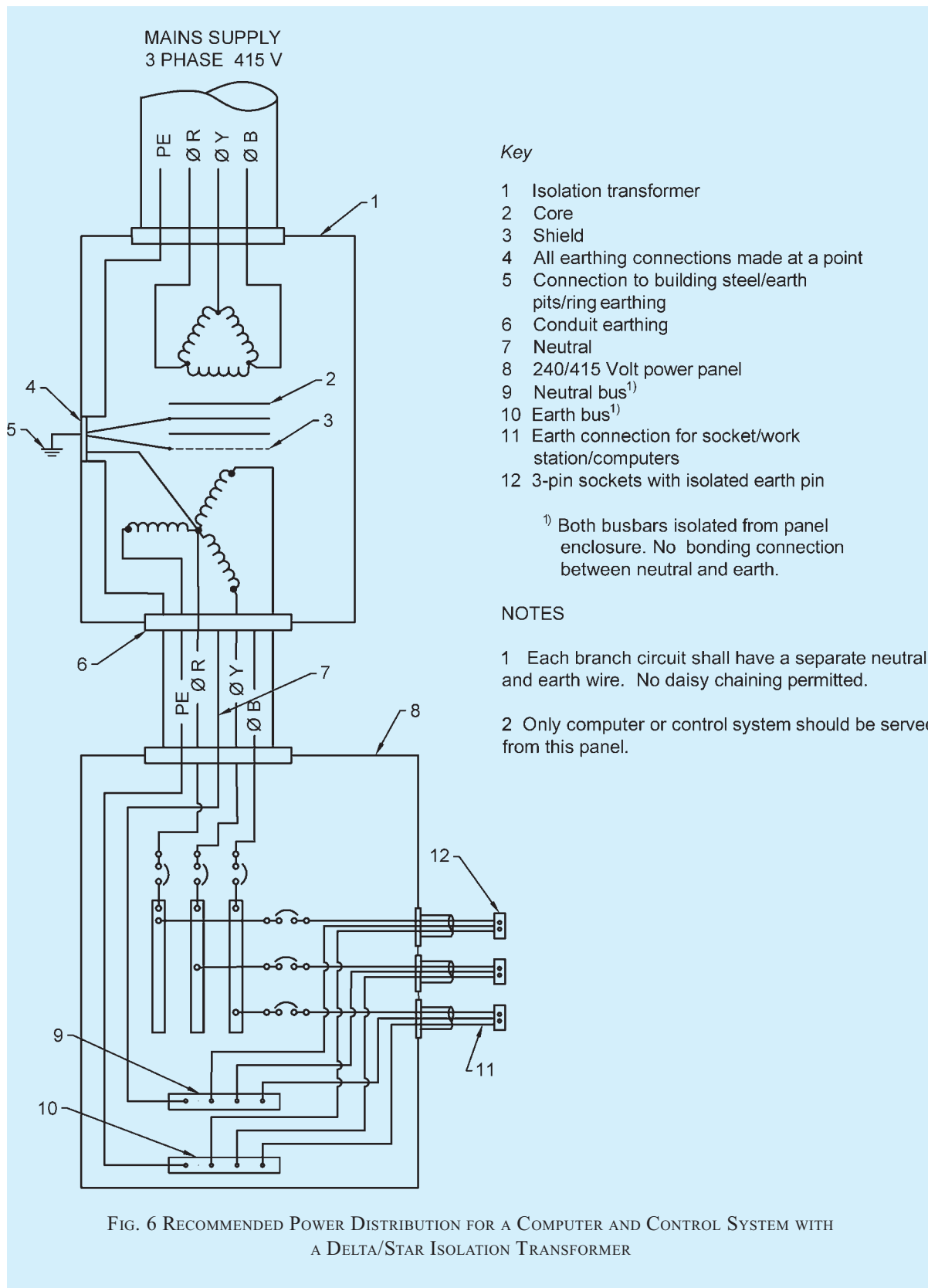

Table 3 Recommended Minimum Size of Commonly Used Earth Electrodes, Embedded in Soil or Concrete Used to Prevent Corrosion and Provide Mechanical Strength¹⁾
(Clause 8.3)

Sl No.	Material and Surface	Shape	Diameter mm	Cross-Sectional Area mm ²	Thickness mm	Weight of Coating g/m ²	Thickness of Coating/Sheathing µm
(1)	(2)	(3)	(4)	(5)	(6)	(7)	(8)
i)	Steel embedded in concrete (bare, hot galvanized or stainless)	Round wire	10	—	—	—	—
		Solid tape or strip	—	75	3	—	—
ii)	Steel hot-dip galvanized ²⁾	Strip ³⁾ or shaped strip/plate — solid plate — lattice plate	—	90	3	500	63
		Round rod installed vertically	16	—	—	350	45
		Round wire installed horizontally	10	—	—	350	45
		Pipe	25	—	2	350	45
		Stranded (embedded in concrete)	—	70	—	—	—
		Cross profile installed vertically	—	(290)	3	—	—
		Round rod installed vertically	(15)	—	—	—	2 000
iv)	Steel with electro-deposited copper coating	Round rod installed vertically	14	—	—	—	250 ⁶⁾
		Round wire installed horizontally	(8)	—	—	—	70
		Strip installed horizontally	—	90	3	—	70
v)	Stainless steel ⁴⁾	Strip ³⁾ or shaped strip/plate	—	90	3	—	—
		Round rod installed vertically	16	—	—	—	—
		Round wire installed horizontally	10	—	—	—	—
		Pipe	25	—	2	—	—
		Strip	—	50	2	—	—
vi)	Copper	Round wire installed horizontally	—	(25) ⁵⁾ 50	—	—	—
		Round rod installed vertically	(12) 15	—	—	—	—
		Stranded wire	1.7 for individual strands of wire	(25) ⁵⁾ 50	—	—	—
		Pipe ⁶⁾	20	—	2	—	—
		Solid plate	—	—	(1.5) 2	—	—
		Lattice plate	—	—	2	—	—
		—	—	—	—	—	—

¹⁾ See IEC 60364-5-54:2011 ‘Low-voltage electrical installations – Part 5-54: Selection and erection of electrical equipment – Earthing arrangements and protective conductors’.

²⁾ The coating shall be smooth, continuous and free from flux stains.

³⁾ As rolled strip or slit strip with round edges.

⁴⁾ Chromium ≥ 16 percent, Nickel ≥ 5 percent, Molybdenum ≥ 2 percent, carbon ≤ 0.08 percent.

⁵⁾ Where experience shows that the risk of corrosion and mechanical damage is extremely low, 16 mm² can be used.

⁶⁾ This thickness is provided to withstand mechanical damage of copper coating during the installation process. It may be reduced to not less than 100 µm where special precautions to avoid mechanical damage of copper during the installation process (for example, drilling holes or special protective tips) are taken according to the manufacturer’s instruction.

NOTES

1 Values in bracket are applicable for protection against electric shock only, while values not in brackets are applicable for lightning protection and for protection against electric shock.

2 Metals inserted inside pipe will not influence in the final earth resistance value.

3 Unprotected ferrous materials are not recommended due to high corrosion (*see* IEC 60364-4-43:2008 ‘Low-voltage electrical installations — Part 4-43: Protection for safety – Protection against overcurrent’).

compound producing low resistance of an earth-termination system. These compounds used for artificial treatment of soil {see good practice [8-2 (44)]} shall satisfy the requirements as per IEC 62561-7:2011 'Lightning protection system components (LPSC) — Part 7: Requirements for earthing enhancing compounds'.

8.4.2 The material of the earthing enhancing compound shall be chemically inert to subsoil. It shall not pollute the environment. It shall provide a stable environment in terms of physical and chemical properties and exhibit low resistivity. The earthing enhancing compound shall not be corrosive to the earth electrodes being used.

8.4.3 The materials used for artificial treatment should also fulfil toxicity characteristic leaching procedure (TCLP) requirements.

8.4.4 Use of salt [sodium chloride (NaCl)] for artificial treatment of soil should be avoided as it accelerates corrosion of ferrous materials.

8.5 Earth Electrode Inspection Housings and Earth Electrode Seals

8.5.1 Earth Electrode Inspection Housing

Earth electrode inspection housing is the metallic or non-metallic enclosure that houses the down-conductor/earth-termination connection for inspection and testing purposes and consists of a housing and a removable lid. The design of the earth electrode inspection housing shall be such that it carries out its function of enclosing the down-conductor/earth rod termination in an acceptable and safe manner, and has sufficient internal dimensions to permit the assembly/disassembly of the earth rod clamp. The housing body shall be deep enough to permit the lid to sit flush on the body without fouling on the rod/conductor/clamp assembly. The material of the earth electrode inspection housing shall be compatible with its surrounding environment and shall comply with the tests given in IEC 62561-5: 2011 'Lightning protection system components (LPSC) — Part 5: Requirements for earth electrode inspection housings and earth electrode seals'.

8.5.2 Earth Electrode Seal

Water pressure seal used in conjunction with an earth rod electrode that passes through the foundation of the building. The design of the earth electrode seal shall be such that it carries out its function of preventing ground water bypassing the earth rod and entering the basement of a building, in an acceptable and safe manner. The material of the earth electrode seal shall be compatible with its surrounding environment and comply with the tests given in IEC 62561-5: 2011 'Lightning protection system components (LPSC) — Part 5: Requirements for earth electrode inspection housings and earth electrode seals'.

8.6 Bonding and Inter connection

All connections made in an earthing system above or below ground should meet electrical conductivity, corrosion resistance, current carrying capacity, and mechanical strength of the conductor. These connections should be strong enough to maintain a temperature rise below that of the conductor and to withstand the effect of heating and the mechanical forces caused by fault currents. Consideration shall be given to electrolytic corrosion when using different materials in an earthing arrangement. The complete connections shall be able to resist corrosion for the intended life of the installation

8.6.1 For external conductors (for example earthing conductor) connected to a concrete-embedded foundation earth electrode, the connection made from hot-dip galvanized steel shall not be embedded in the soil

8.6.2 Where an earth electrode consists of parts that must be connected together, the connection shall be by exothermic welding, pressure connectors, clamps or other suitable mechanical connectors.

8.6.3 All connection components shall meet the requirements according to IEC 62561-1:2012 'Lightning protection system components (LPSC) — Part 1: Requirements for connection components'.

8.7 Equipment and Portions of Installations which shall be Earthed

8.7.1 Equipment to be Earthed

Except for equipment provided with double insulation, all the non-current carrying metal parts of electrical installations are to be earthed properly. All metal conduits, trunking, cable sheaths, switchgear, distribution fuse boards, lighting fittings and all other parts made of metal shall be bonded together and connected by means of two separate and distinct conductors to an efficient earth electrode.

8.7.2 Structural Metal Work

Earthing of metallic parts of the structure shall be done according to good practices [8-2(44)] and [8-2(45)].

8.8 Neutral Earthing

To comply with relevant Central Electricity Authority regulations, no fuses or circuit breakers other than a linked circuit breaker shall inserted in an earthed neutral conductor, a linked switch or linked circuit breaker shall be arranged to break or the neutral either with or after breaking all the related phase conductors and. Shall positively make (or close) the neutral before making (or closing) the phases.

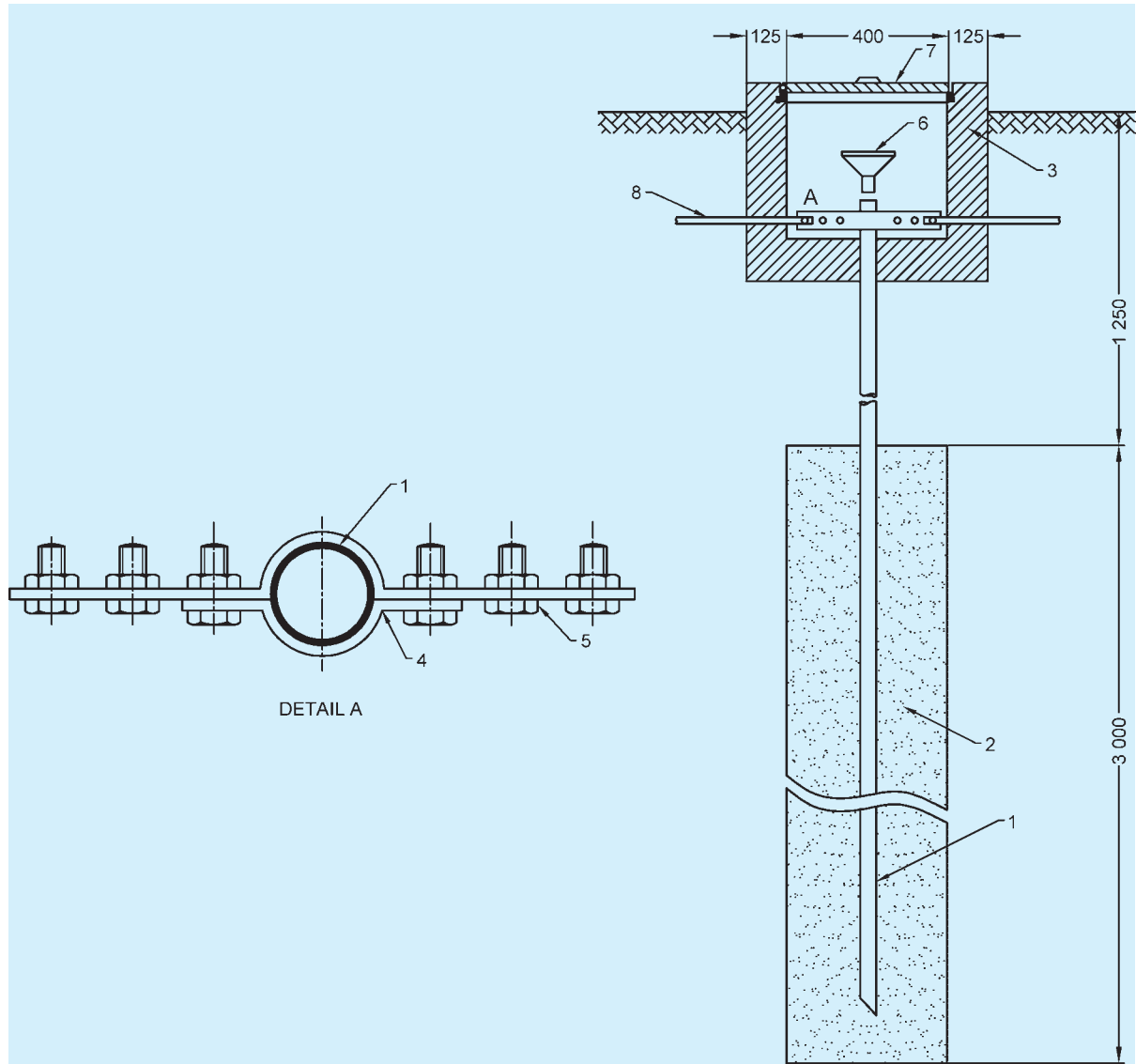

Key

- 1 a) CI pipe 100 mm ID (*Min*), 13 mm thick (*Min*)
b) GI pipe (class B)/MS Rod, 40 mm ID (*Min*)
- 2 Earth enhancement material [confirming to IEC 62561-7:2011 'Lightning protection system components (LPSC) — Part 7: Requirements for earthing enhancing compounds'], or sand, salt and charcoal
- 3 Inspection chamber
- 4 Universal stainless steel clamp, or 50 × 3 mm GI strip
- 5 M10 bolts and nuts
- 6 Funnel (for maintenance/watering)
- 7 CI lid/cover
- 8 50 × 6 mm GI strip

All dimensions in millimetres.

NOTE — Inspection housing can also be of FRP materials with CI cover tested according to IEC 62561-5:2011 'Lightning protection system components (LPSC) — Part 5: Requirements for earth electrode inspection housings and earth electrode seals'.

7A TYPICAL ARRANGEMENT OF EARTHING WITH PIPE ELECTRODE
(WITH MAINTENANCE ARRANGEMENT)

FIG. 7 — (*Continued*)

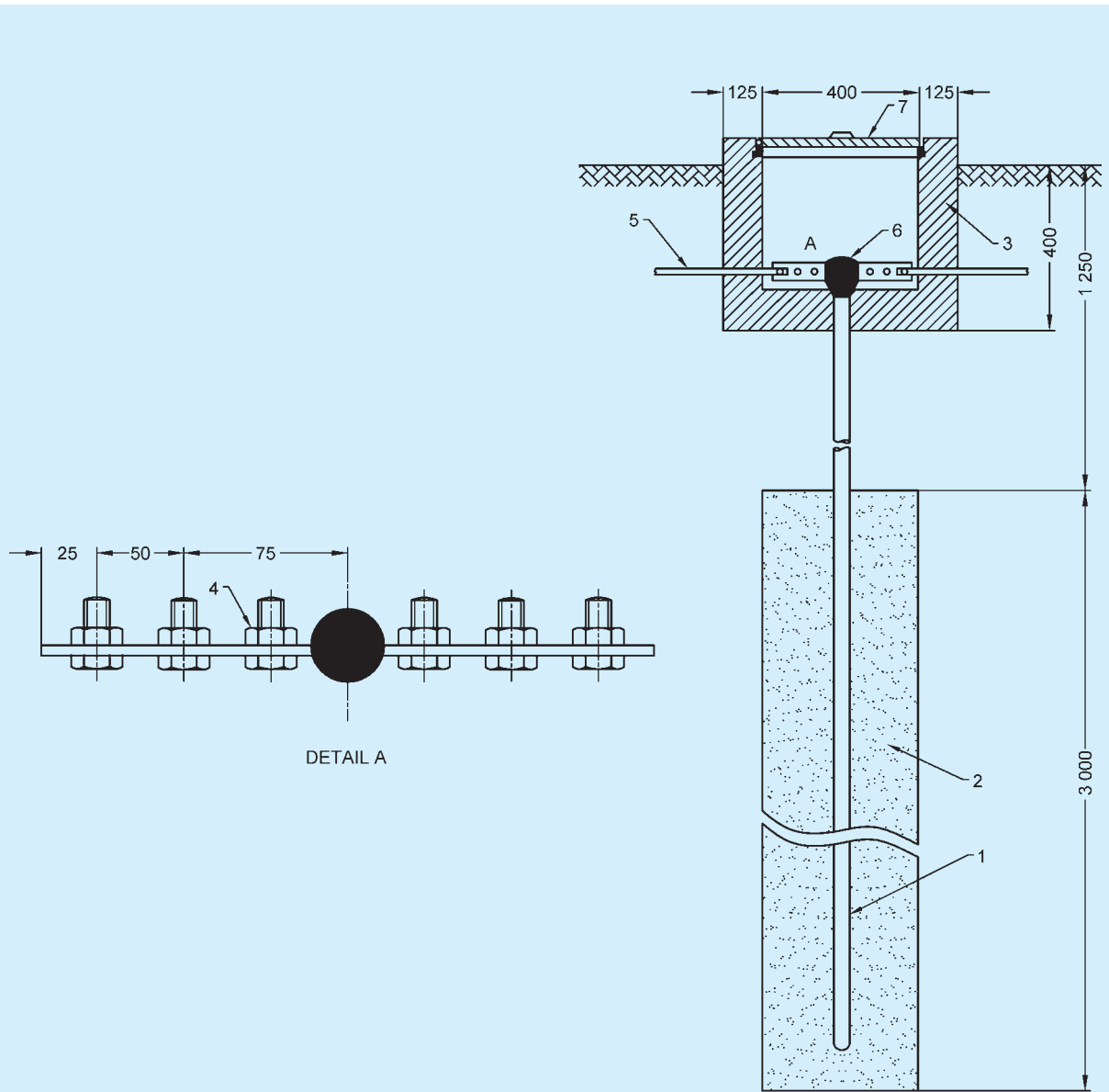

Key

- 1 Copper/copper bonded steel rod (see Table 3 for sizes)
- 2 Earth enhancement material [conforming to IEC 62561-7:2011 'Lightning protection system components (LPSC) — Part 7: Requirements for earthing enhancing compounds']
- 3 Inspection chamber
- 4 M10 bolts and nuts
- 5 Copper strip — 25 x 6 mm or higher
- 6 Exothermic welding
- 7 CI lid/cover

All dimensions in millimetres.

NOTE — Inspection housing can also be of FRP materials with CI cover tested according to IEC 62561-5:2011 'Lightning protection system components (LPSC) — Part 5: Requirements for earth electrode inspection housings and earth electrode seals'.

7B TYPICAL ARRANGEMENT OF EARTHING WITH COPPER/COPPER BONDED ELECTRODE WITH EXOTHERMIC WELDING (MAINTENANCE FREE ARRANGEMENT)

FIG. 7 TYPICAL ARRANGEMENT OF ELECTRODE EARTHING

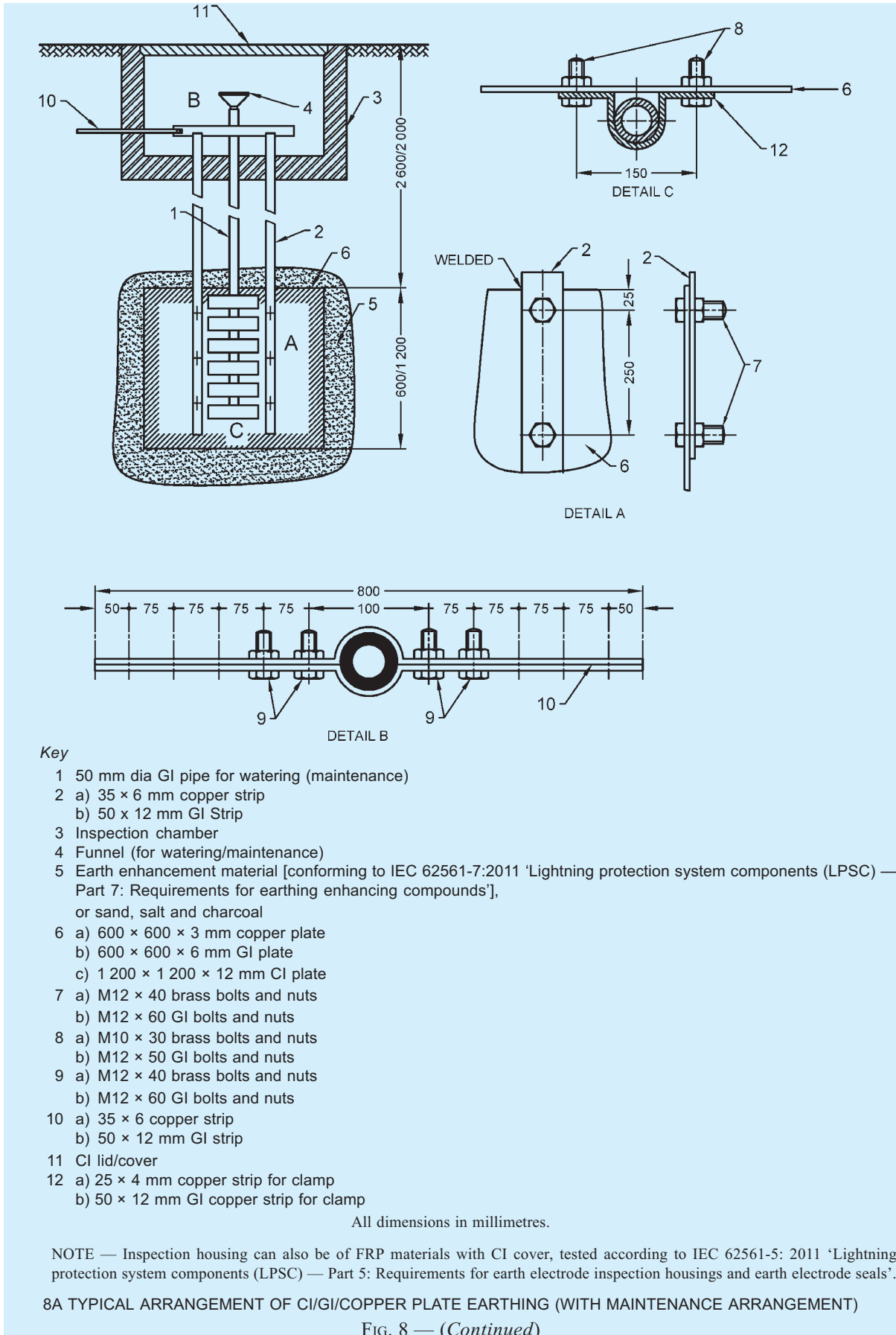

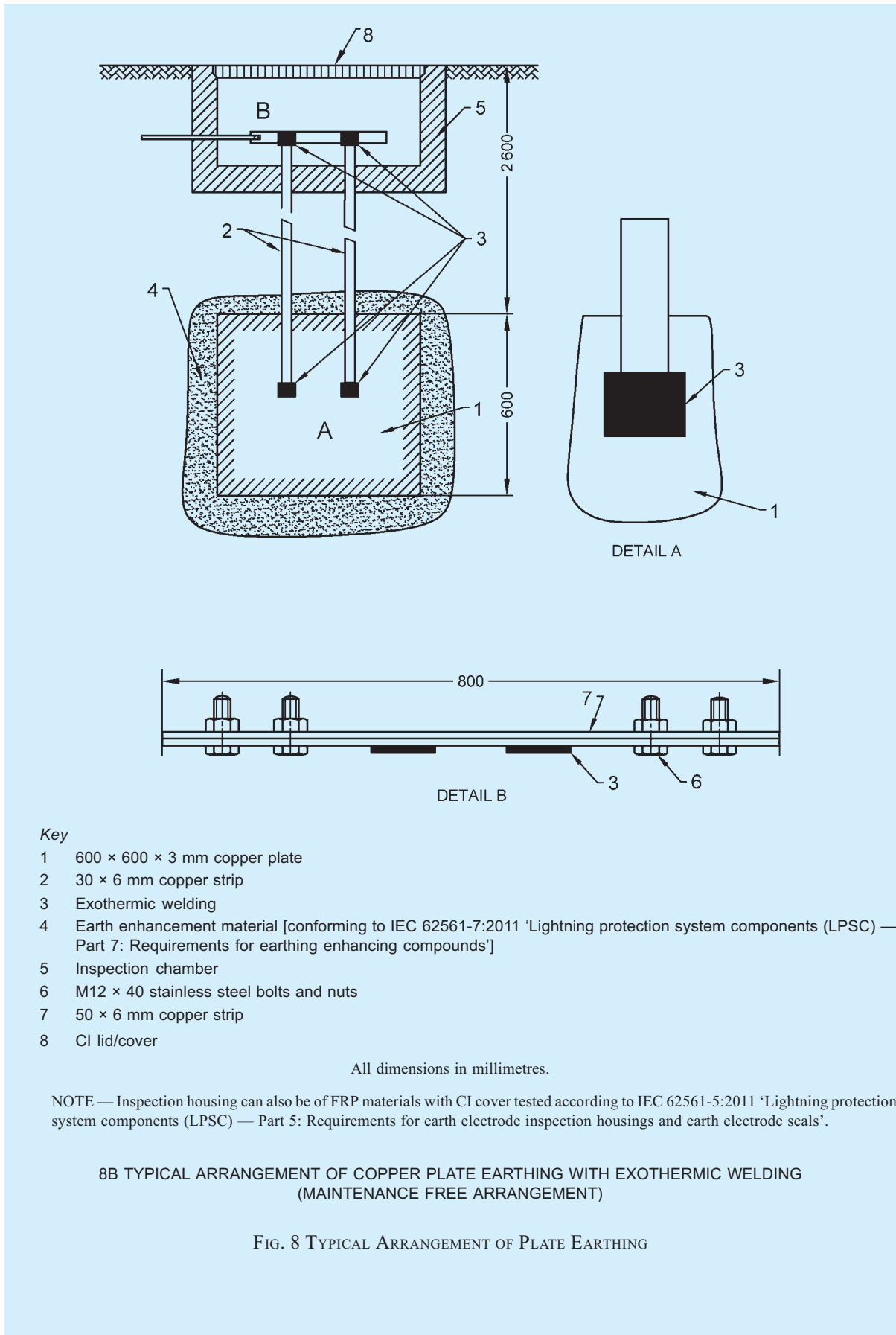





1		Three rods at the vertices of an equilateral triangle
2		Two strips set at right angles to each other, meeting at one corner
3		Vertical electrodes interconnected as a square
4		Three strips set at 120°, meeting at the star point, all of equal length
5		Four strips set in a cruciform
6		Vertical rod 1 Extensible earth rod 2 Rod coupling 3 Soil 4 Conductor to rod clamp 5 Earthing conductor

FIG. 9 MISCELLANEOUS ELECTRODE CONFIGURATIONS

If this neutral point of the supply system is connected permanently to earth, then the above rule applies throughout the installation including 2-wire final circuits. This means that no fuses may be inserted in the neutral or common return wire. And the neutral should consist of a bolted solid link, or part of a linked switch, which completely disconnects the whole system from the supply. This linked switch shall be so arranged that the neutral makes before, and break after the phases.

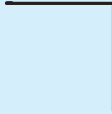
8.9 System of Earthing

Equipment and portions of installations shall be deemed to be earthed only if earthed in accordance with either the direct earthing system, the multiple earthed neutral system or the earth leakage circuit-breaker system. In all cases, the relevant provisions of Central Electricity

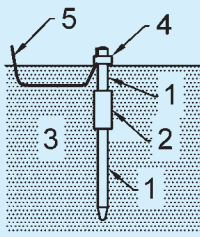
Authority regulation shall be complied with.

8.10 The earthing of electrical installations for non-industrial and industrial buildings shall be done in accordance with good practice [8-2(44)].

9 INSPECTION, TESTING AND VERIFICATION OF INSTALLATION

9.1 General Requirements

9.1.1 Before the completed installation, or an addition to the existing installation, is put into service, inspection and testing shall be carried out in accordance with the *Central Electricity Authority (Measures Relating to Safety and Electric Supply) Regulations, 2010*, as amended from time-to-time. In this connection, Regulation 4, 5, 5A, 8, 30, 31, 32, 40 and 46 of the

regulation shall be complied with (*see* Annex B). In the event of defects being found, these shall be rectified, as soon as practicable and the installation retested.

9.1.2 Periodic inspection and testing shall be carried out in order to maintain the installation in a sound condition after putting into service.

9.1.3 Where an addition is to be made to the fixed wiring of an existing installation, the latter shall be examined for compliance with the recommendations of the Code.

9.1.4 The individual equipment and materials which form part of the installation shall generally conform to the relevant Indian Standard specification, wherever applicable. If there is no relevant Indian Standard specification for any item, these shall be approved by the appropriate authority.

9.1.5 Completion Drawings

On completion of the electric work, a wiring diagram shall be prepared and submitted to the Engineer-in-Charge or the owner. All wiring diagrams shall indicate clearly, the main switch board, the runs of various mains and submains and the position of all points and their controls. All circuits shall be clearly indicated and numbered in the wiring diagram and all points shall be given the same number as the circuit in which they are electrically connected. Also the location and number of earth points and the run of each loads should be clearly shown in the completion drawings.

9.2 Inspection of the Installation

9.2.1 General

On completion of wiring a general inspection shall be carried out by competent personnel in order to verify that the provisions of this Code and that of *Central Electricity Authority (Measures Relating to Safety and Electric Supply) Regulations, 2010*, have been complied with. This, among other things, shall include checking whether all equipment, fittings, accessories, wires/cables, used in the installation are of adequate rating and quality to meet the requirement of the load. General workmanship of the electrical wiring with regard to the layout and finish shall be examined for neatness that would facilitate easy identification of circuits of the system, adequacy of clearances, soundness, contact pressure and contact area. A complete check shall also be made of all the protective devices, with respect to their ratings, range of settings and coordination between the various protective devices.

9.2.2 Item to be Inspected

All equipment in a substation including HV panel, transformer, LV panel, emergency DG sets, battery bank, cables, cable terminations, etc, need inspection.

Healthiness of the main distribution boards, metering panels, distribution cables, rising mains, bus ducts, etc, need to be verified along with earthing system.

9.2.2.1 Substation installations

In substation installation, it shall be checked whether,

- 1) the installation has been carried out in accordance with the approved drawings;
- 2) phase to phase and phase to earth clearances are provided as required;
- 3) all equipment are efficiently earthed and properly connected to the required number of earth electrodes;
- 4) HV and MV/LV switchgears are all vermin and damp-proof and all unused openings or holes are blocked properly;
- 5) the required ground clearance to live-terminals is provided;
- 6) suitable fencing is provided with gate with lockable arrangements;
- 7) there is no vegetation in outdoor substation;
- 8) the required number of caution boards, fire-fighting equipment, operating rods, rubber mats, etc, are kept in the substation;
- 9) in case of indoor substation sufficient ventilation and draining arrangements are made;
- 10) all cable trenches are provided with non-inflammable covers;
- 11) free accessibility is provided for all equipment for normal operation;
- 12) all name plates are fixed and the equipment are fully painted;
- 13) all construction materials and temporary connections are removed;
- 14) oil-level, bus bar tightness, transformer tap position, etc, are in order;
- 15) earth pipe troughs and cover slabs are provided for earth electrodes/earth pits and the neutral and lightning arrestor earth pits are marked for easy identification;
- 16) earth electrodes are of GI pipes or CI pipes or copper plates or Cu bonded rods as per Table 3. For earth connections, brass bolts and nuts with lead washers are provided in the pipes/plates;
- 17) earth pipe troughs and oil sumps/pits are free from rubbish and dirt and stone jelly and the earth connections are visible and easily accessible;
- 18) earthing system designed are periodically checked for permissible limits of step and touch potential.

- 19) the earth bus bars have tight connections and corrosion-free joint surfaces;
- 20) operating handle of protective device are provided at an accessible height from ground, that is, 300 mm to 1 800 mm;
- 21) adequate headroom is available in the transformer room for easy topping-up of oil, maintenance, etc;
- 22) safety devices, horizontal and vertical barriers, bus bar covers/shrouds, automatic safety shutters/doors interlock, handle interlock are safe and in reliable operation in all panels and cubicles;
- 23) clearances in the front, rear and sides of the main HV and MV and sub-switch boards are adequate;
- 24) the switches operate freely; the 3 blades make contact at the same time, the arcing horns contact in advance; and the handles are provided with locking arrangements;
- 25) insulators are free from cracks, and are clean;
- 26) in transformers, there is any oil leak;
- 27) connections to bushing in transformers for tightness and good contact;
- 28) bushings are free from cracks and are clean;
- 29) accessories of transformers like breathers, vent pipe, buchholz relay, etc, are in order;
- 30) connections to gas relay in transformers are in order;
- 31) oil and winding temperature are set for specific requirements in transformers;
- 32) in case of cable cellars, adequate arrangements to pump out water that has entered due to seepage or other reasons;
- 33) all incoming and outgoing circuits of HV and MV panels are clearly and indelibly labelled for identifications;
- 34) no cable is damaged;
- 35) there is adequate clearance around the equipment installed; and
- 36) cable terminations are proper.

9.2.2.2 Medium/low voltage installation

In medium and low voltage installations, it shall be checked whether,

- a) all blocking materials that are used for safe transportation in switchgears, contactors, relays, etc, are removed;
- b) all connections to the earthing system are feasible for periodical inspection;
- c) sharp cable bends are avoided and cables are taken in a smooth manner in the trenches or

alongside the walls and ceilings using suitable support clamps at regular intervals;

- d) suitable circuit breaker or lockable push button is provided near the motors/apparatus for controlling supply to the motor/apparatus in an easily accessible location;
- e) two separate and distinct earth connections are provided for the motor/apparatus;
- f) control switch-fuse is provided at an accessible height from ground for controlling supply to overhead travelling crane, hoists, overhead bus bar trunking;
- g) the metal rails on which the crane travels are electrically continuous and earthed and bonding of rails and earthing at both ends are done;
- h) four core cables are used for overhead travelling crane and portable equipment, the fourth core being used for earthing, and separate supply for lighting circuit is taken;
- j) if flexible metallic hose is used for wiring to motors and other equipment, the wiring is enclosed to the full lengths, and the hose secured properly by approved means;
- k) the cables are not taken through areas where they are likely to be damaged or chemically affected;
- m) the screens and armours of the cables are earthed properly;
- n) the belts of the belt driven equipment are properly guarded;
- p) adequate precautions are taken to ensure that no live parts are so exposed as to cause danger;
- q) ammeters and voltmeters are tested;
- r) the relays are inspected visually by moving covers for deposits of dusts or other foreign matter;
- s) wherever bus ducts/rising mains/overhead bus trucking are used, special care being taken for earthing the system. All tap off points are provided with adequately rated protective device like MCB, MCCB, fuses, RCCB/RCD, SPD (*see 11*), etc;
- t) all equipment are weather, dust and vermin proof; and
- u) any and all equipment having air insulation as media maintain proper distances between phases; phase to neutral; phase to earth and earth to neutral.

9.2.2.3 Overhead lines

For overhead lines, it shall be checked whether,

- a) all conductors and apparatus including live

- parts thereof are inaccessible;
- b) the types and size of supports are suitable for the overhead lines/conductors used and are in accordance with approved drawing and standards;
- c) clearances from ground level to the lowest conductor of overhead lines, sag conditions, etc, are in accordance with 4.7;
- d) where overhead lines cross the roads or cross each other or are in proximity with one another, suitable guarding is provided at road crossings and also to protect against possibility of the lines coming in contact with one another;
- e) every guard wire is properly earthed;
- f) the type, size and suitability of the guarding arrangement provided is adequate;
- g) stays are provided suitably on the overhead lines as required and are efficiently earthed or provided with suitably stay insulators of suitable voltages;
- h) anti-climbing devices and danger board/caution board, notices are provided on all HV supports;
- j) clearances along the route are checked and all obstructions, such as, trees/branches and shrubs are cleared on the route to the required distance on either side;
- k) clearance between the live conductor and the earthed metal parts are adequate;
- m) for the service connections tapped-off from the overhead lines, cut-outs of adequate capacity are provided;
- n) all insulators are properly and securely mounted; also they are not damaged.
- p) all poles are properly grouted/insulated so as to avoid bending of pole towards tension; and
- q) steel poles, if used is properly earthed.
- d) the plug points (16 A) in the lighting circuit are all of 3/6-pin type, the third pin being suitably earthed;
- e) tamper-proof interlocked switch socket and plug are used for locations easily accessible;
- f) lighting wiring in factory area is taken enclosed in conduit and conduit properly earthed, or alternatively, armoured cable wiring is used;
- g) a separate earth wire is run in the lighting installation to provide earthing for plug points, fixtures and equipment;
- h) proper connectors and junction boxes are used wherever joints are to be made in conductors or cross-over of conductors takes place;
- j) cartridge fuse units are fitted with cartridge fuses only;
- k) clear and permanent identification marks are painted in all distribution boards, switchboards, sub-main boards and switches as necessary;
- m) the polarity has been checked and all protective devices (such as MCB, MCCB, fuses, RCCB/RCD, etc) and single pole switches are connected on the phase conductor only and wiring is correctly connected to socket-outlets;
- n) spare knockouts provided in distribution boards and switch fuses are blocked;
- p) the ends of conduits enclosing the wiring leads are provided with ebonite or other suitable bushes;
- q) the fittings and fixtures used for outdoor use are all of weather-proof construction and of suitable IP and IK rating, and similarly, fixtures, fittings and switchgears used in the hazardous area, are of flame-proof application;
- r) proper terminal connectors are used for termination of wires (conductors and earth leads) and all strands are inserted in the terminals;
- s) flat ended screws are used for fixing conductor to the accessories;
- t) use of flat washers backed up by spring washers for making end connections is desirable; and
- u) all metallic parts of installation, such as conduits, distribution boards, metal boxes, etc, have been properly earthed.

9.2.2.4 Lighting and convenience power circuits

For the lighting and convenience power circuits, it shall be checked whether,

- a) wooden boxes and panels are avoided in factories for mounting the lighting boards and switch controls, etc;
- b) neutral links are provided in double pole switch-fuses which are used for lighting control, and no protective device (such as MCB, MCCB, fuses, RCCB/RCD, etc) is provided in the neutral;
- c) the plug points (6 A) in the lighting circuit are all of 3/5-pin type, the third pin being suitably earthed;

9.3 Testing of Installation

9.3.1 General

After inspection, the following tests shall be carried

out, before an installation or an addition to the existing installation is put into service. Any testing of the electrical installation in an already existing installation shall commence after obtaining permit to work from the Engineer-in-Charge and after ensuring the safety provisions.

Testing of the installations will cover the testing of equipment, connections, cables, switchgear, protective devices, circuit breakers and the associated relays, measuring instruments and earthing. Periodicity of testing should not exceed six months. More frequent testing may be prescribed for complex installations and installations feeding sensitive loads. Due date of next test cycle should be displayed on the equipment.

9.3.2 Testing

9.3.2.1 Switchboards

HV and MV switchboards shall be tested in the manner indicated below:

- a) All high voltage switchboards shall be tested for dielectric test as per good practice [8-2(14)].
- b) All earth connections shall be checked for continuity.
- c) The operation of the protective devices shall be tested by means of secondary or primary injection tests.
- d) The operation of the breakers shall be tested from all control stations.
- e) Indication/Signalling lamps shall be checked for proper working.
- f) The operation of the breakers shall be tested for all interlocks.
- g) The closing and opening timings of the breakers shall be tested, wherever required for auto-transfer schemes.
- h) Contact resistance of main and isolator contacts shall be measured.
- j) The specific gravity and the voltage of the control battery shall be measured.

9.3.2.2 Transformers

Transformers shall be tested in the manner indicated below:

- a) All commissioning tests shall be in accordance with good practice [8-2(9)].
- b) Insulation resistance on HV and MV windings shall be measured at the end of 1 min as also at the end of 10 min of measuring the polarization index. The absolute value of insulation resistance should not be the sole criterion for determining the state of dryness of the insulation. Polarization index values

should form the basis for determining the state of dryness of insulation. For any class of insulation, the polarization index should be greater than 1.5.

9.3.2.3 Cables

Cable installations shall be checked as given below:

- a) It shall be ensured that the cables conform to the relevant Indian Standards. Tests shall also be done in accordance with good practice [8-2(11)] and [8-2(15)]. The insulation resistance before and after the tests shall be checked.
- b) The insulation resistance between each conductor and against earth shall be measured. The insulation resistance varies with the type of insulation used and with the length of cable. The following empirical rule gives reasonable guidance:
Insulation resistance = $\frac{10 \times \text{Voltage, in kV}}{\text{Length, in km}}$
in megaohms
- c) Physical examination of cables shall be carried out.
- d) Cable terminations shall be checked.
- e) Continuity test shall be performed before charging the cable with current.

9.3.2.4 Motors and other equipment

The following tests shall be made on motor and other equipment.

The insulation resistance of each phase winding against the frame and between the windings shall be measured. Megger of 500 V or 1 000 V rating shall be used. Star points should be disconnected. Minimum acceptable value of the insulation resistance varies with the rated power and the rated voltage of the motor.

The following relation may serve as a reasonable guide:

$$R_1 = \frac{20 \times E_n}{1000 + 2P}$$

where

- R_1 = insulation resistance in mega-ohms at 25°C.
 E_n = rated phase to phase voltage.
 P = rated power, in kW.

If the resistance is measured at a temperature different from 25°C, the value shall be corrected to 25°C.

The insulation resistance as measured at ambient temperature does not always gives a reliable value, since moisture may have been absorbed during shipment and storage. When the temperature of such a motor is raised, the insulation resistance will initially drop considerably, even below the acceptable minimum. If any suspicion

exists on this score, motor winding shall be dried out.

9.3.2.5 *Wiring installation*

The following tests shall be done:

- a) The insulation resistance shall be measured by applying between earth and the whole system of conductor or any section thereof with all fuses in place and all switches closed, and except in earthed concentric wiring, all lamps in position or both poles of installation otherwise electrically connected together, a d.c. voltage of not less than twice the working voltage, provided that it does not exceed 500 V for medium voltage circuits. Where the supply is derived from three-wire (a.c. or d.c.) or a poly-phase system, the neutral pole of which is connected to earth either direct or through added resistance the working voltage shall be deemed to be that which is maintained between the outer or phase conductor and the neutral.
- b) The insulation resistance in mega-ohm of an installation measured as in (a) shall be not less than 50 divided by the number of points on the circuit, provided that the whole installation need not be required to have an insulation resistance greater than one mega-ohm.
- c) Control rheostats, heating and power appliances and electric signs, may, if desired, be disconnected from the circuit during the test, but in that event the insulation resistance between the case of framework, and all live parts of each rheostat, appliance and sign shall be not less than that specified in the relevant Indian Standard specification or where there is no such specification, shall be not less than half a mega-ohm.
- d) The insulation resistance shall also be measured between all conductors connected to one pole or phase conductor of the supply and all the conductors connected to the middle wire or to the neutral on to the other pole of phase conductors of the supply. Such a test shall be made after removing all metallic connections between the two poles of the installation and in these circumstances the insulation resistance between conductors of the installation shall be not less than that specified in (b).

9.3.2.6 *Completion certificate*

On completion of an electrical installation (or an extension to an installation) a certificate shall be furnished by the contractor, counter-signed by the certified supervisor under whose direct supervision the

installation was carried out. This certificate shall be in a prescribed form as required by the local electric supply authority. One such recommended form is given in Annex G. This is a general form giving the minimum basic requirements and the items in the form have to be augmented keeping in view the features of the particular equipment, system or installation and environmental conditions of its operation.

9.3.2.7 *Earthing*

For checking the efficiency of earthing, the following tests shall be done:

- a) The earth resistance of each electrode shall be measured.
- b) Earth resistance of earthing grid shall be measured.
- c) All electrodes shall be connected to the grid and the earth resistance of the entire earthing system shall be measured.

These tests shall preferably be done during the summer months.

9.4 Checklists covering basic minimum set of checks for installation, handing over and commissioning of typical equipment of a substation are given in Annex E for general reference and use. Checklist for handing over of earthing pits is given in Annex F for general reference and use. For any installation, the proper checklist should be developed keeping in view the type of loads, quality of service, environmental conditions and operating requirements of redundancy and reliability.

10 ALLIED/MISCELLANEOUS SERVICES

Requirements relating to various allied services shall be as per **10.1** to **10.9**.

10.1 **Telecommunication and Information and Communication Technology Services**

10.1.1 *Telephone Services*

10.1.1.1 House wiring of telephone subscribers in small buildings may be on the surface of walls or desirably, in a concealed manner through conduits. In large multi-storeyed buildings intended for commercial, business and office use as well as for residential purposes, wiring for telephone connections should be done in a concealed manner through conduits. The requirements of telecommunication facilities like telephone connections, private branch exchange and intercommunication facilities, should be planned well in advance so that suitable provisions are made in the building plan in such a way that the demand for telecommunication services in any part of the building at any floor are met at any time during the life of the building.

10.1.1.2 Layout arrangements, methods for internal block wiring and other requirements regarding provisions of space, etc, may be decided depending on the number of phone outlets and other details in consultation with engineer/architect and user. *See also* Part 8 ‘Building Services, Section 6 Information and Communication Enabled Installations’ of the Code.

10.1.2 *Information and Communication Technology Services including Computer Networking* *See* Part 8 ‘Building Services, Section 6 Information and Communication Enabled Installations’ of the Code.

10.2 Public Address System — *See* Part 4 ‘Fire and Life Safety’ of the Code.

10.3 Common Antenna System for TV Receivers

10.3.1 In multi-storeyed apartments, houses and hotels where many TV receivers are located, a common master antenna system may preferably be used to avoid mushrooming of individual antennas.

10.3.2 Master antenna is generally provided at the top most convenient point in any building and a suitable room on the top most floor or terrace for housing the amplifier unit, etc, may also be provided in consultation with the architect/engineer.

10.3.3 From the amplifier rooms, conduits should be laid in recess to facilitate drawing co-axial cable to individual flats. Suitable ‘Tap Off’ boxes may be provided in every room/flat, as required.

10.4 Emergency and Standby Power Supply Systems

10.4.1 General

Use of electricity has grown tremendously and for various activities the dependence on electricity has increased to such an extent as to cause serious problems even with loss of electrical power for a few moments. As a result, a wide variety of alternate sources of electricity are being in our built environment.

The different alternative sources of power are the Uninterrupted Power Supply (UPS) System, inverter, CNG/LPG generator sets, diesel/petrol/kerosene oil generator sets, bio-gas generator sets.

In addition to the above, there is a proliferation of power sources, such as solar photo-voltaic cells, wind generators, bio-mass and waste based power plants etc, primarily oriented towards reduction of the environmentally harmful CO₂ emissions.

These systems give electricity during the periods of the failure of the conventional grid based public energy system and keep our critical systems in continued operation. However, introduction of more than one source of electrical power introduces questions of

safety. For safety from electrical shock to human beings or livestock, the hazard is not just dependent on the main high powered source such as the grid, but the hazard is the same from a low powered source also. Shock from a small 20 W inverter can be as dangerous as a shock from the grid with megawatts of power at the back. As such precautions from the angle of safety apply equally to all sources of power. Electric shock hazards are dependent on the system voltage and as such even a low capacity generator or an inverter (of capacity 100 VA) poses the same level of shock hazard as a multi-kilovolt ampere capacity generator and all protection provisions (such as safety earthing, earth leakage and overload breakers) shall be provided as done for a large capacity system.

Power devices contain fuel, batteries which are points of concentrated sources of energy constrained in a small place. Any unintended improper release of this bottled up energy can unleash devastating consequences, such as fire and as such care is required in location which houses any of these sources of electrical power and its associated components.

10.4.2 Uninterrupted Power Supply (UPS) System

UPS is an electrical device providing an interface between the mains power supply and sensitive loads (computer systems, instrumentation, etc). The UPS supplies sinusoidal a.c. power free of disturbances and within strict amplitude and frequency tolerances. It is generally made up of a rectifier/charger and an inverter together with a battery for backup power in the event of a mains failure with virtually no time lag.

In general UPS system shall be provided for sensitive electronic equipment like computers, printers, fire alarm panel, public address system equipment, access control panel, EPABX, etc, with the following provisions:

- a) Isolation transformers may be provided in many UPS systems to provide higher grade of power supply quality to the loads fed by the UPS.
- b) UPS shall have dedicated neutral earth pits. This earth pit shall be interconnected with other earth pits below soil for equipotential bonding.
- c) Adequate rating of protective devices such as MCB, MCCB, fuses, RCCB/RCD, etc, shall be provided at both incoming and outgoing sides.
- d) UPS room shall be provided with adequate ventilation and/or air conditioning as per requirement.
- e) For all 3 phase UPS, 4 pole CB (circuit breaker) shall be used and for all 1 phase UPS, Double Pole CB shall be used.

10.4.3 Inverter

In general inverter system shall be provided for house lighting, shop lighting, etc.

NOTE — While a UPS system is provided to maintain power supply without any break even in the event of a failure of the incoming power supply, an inverter system is provided where a short break is acceptable.

Inverter systems also have a battery bank to supply power during the failure of the main power supply and the battery charged through a rectifier. The following provisions shall apply to inverter systems:

- a) Adequate rating of protective devices such as MCB, MCCB, fuses, RCCB/RCD, etc, shall be provided at both incoming and outgoing sides.
- b) Earthing shall be done properly.
- c) Adequate ventilation space shall be provided around the battery section of the inverter.
- d) Care shall be taken in circuit design to keep the connected load in such a manner that the demand at the time of mains failure is within the capability of the inverter.

NOTE — If the inverter fails to take over the load at the time of the mains failure, the purpose of providing the inverter and battery backup is defeated.

10.4.4 The following provisions shall apply to both inverter and UPS systems:

- a) Circuits which are fed by the UPS or inverter systems should have suitable marking to ensure that a workman does not assume that the power is off, once he has switched off the mains from the DB for maintenance.
- b) Electric shock hazards are dependent on the system voltage and as such even a low capacity generator or an inverter (of capacity 100 VA) poses the same level of shock hazard as a multi-kilovolt ampere capacity generator and all protection provisions (such as safety earthing, earth leakage and overload breakers) shall therefore be provided as done in case of a large capacity system.
- c) UPS and inverter systems should be provided with protection to shut the output during abnormal conditions, such as overload or short circuit. Such systems may also have the choice of auto-restoration after a preset time delay and an ultimate lock-out after a number of restoration attempts. Warning should be displayed wherever the possibility of automatic restoration is possible.
- d) Batteries that go with UPS and inverter systems are required to be placed in well-ventilated spaces as oxygen and hydrogen

gasses are produced in the batteries, which unless ventilated, can cause explosive conditions.

- e) The flooring for the battery room should be with acid (or alkali as the case may be) resistant tiles or coating.

10.4.5 Standby Generating Set (less than 5 kVA)

In general, small standby generating sets (using either diesel or petrol or kerosene or LPG or CNG) may be provided for small installations, such as offices, shops, small scale industry, hostels, etc, which shall comply the following requirements:

- a) These shall be located outside in open areas.
- b) There shall be no risk of fire due to presence of such equipment in the premise.
- c) They shall be in reach of authorized persons only.
- d) Adequate firefighting equipment shall be provided near such installations.
- e) Exhaust from these shall be disposed in such a way so as not to cause health hazard.

NOTE — Installation of a set in a closed space poses the hazard of accumulation of the exhaust gasses which contains harmful gases such as carbon monoxide, and also reduction of oxygen in the air in the enclosure.

- f) These shall have acoustic enclosure, or shall be placed at a location so as not to cause noise pollution.
- g) Adequate ventilation shall be provided around the installation.
- h) Protective devices such as MCB, MCCB, fuses, RCCB/RCD, etc, with adequate rating shall be provided.
- j) Separate and adequate body and neutral earthing shall be done.
- k) Cumulative capacity shall not exceed 10 kVA.

10.5 Building Management System

A building management/automation system may be considered to be provided for controlling of some and monitoring of all parameters of heating, ventilation and air conditioning system (HVAC); electrical; plumbing; fire fighting; low voltage system, such as telephone, TV; etc. This not only leads to reduction of energy consumption, it also generates data leading to better operation practice and systematic maintenance scheduling. The total overview provided by a building automation system, with a capability to oversee a large number of operating and environmental parameters on real time basis leads to introduction of measures which further leads to reduction in energy consumption.

It also helps in reduction in skilled manpower

requirement for operation and maintenance of large complexes. This system can further be linked to other systems such as fire alarm system, public address system, etc for more effective running of services. This system can be used for analysis and controlling of all services in a particular complex, leading to efficient and optimum utilization of available services.

NOTE — See Part 8 'Building Services, Section 3 Air Conditioning, Heating and Mechanical Ventilation' and Part 12 'Asset and Facility Management' of the Code for provisions relating to building management system.

10.6 Security System

Security system may comprise an integrated closed circuit television system, access control system, perimeter protection systems, movement sensors, etc. These have a central control panel, which has a defined history storage capacity. This main control panel may be located near to the fire detection and alarm system.

These may be considered for high security areas or large crowded areas or complexes. High security areas may consider uncorded, high-resolution, black and white cameras in place of coloured cameras. These cameras may be accompanied or automatically controlled with movement sensors. Cameras may be linked to access controls so that proper recording of the movement at the points of access to high security areas is maintained.

Access control may be provided for entry to high security areas. The systems may have proximity card readers, magnetic readers, etc.

NOTE — See Part 12 'Asset and Facility Management' of the Code for provisions relating to security system.

10.7 Car Parking Area

10.7.1 Electrical Vehicle Charging

Adequate electrical provisioning should be made for electric vehicle charging in designated spaces for electric car parks in enclosed/covered car parking. These electrical outlets should be fed from a separate distribution board located near such outlets for electric car parks. Distribution board and outlets should be protected and metered.

NOTE — Reference may be made to IEC 60364-7-722:2015 'Low-voltage electrical installations — Part 7-722: Requirements for special installations or locations — Supplies for electric vehicles'.

10.7.2 Car Park Management System

Wherever car park management system is provided in multi-level parking or other parking lots with features of boom barriers, pay and display machines (manned or unmanned type) and parking guidance system (for displaying number of car spaces vacant on various floors, direction of entry and exit, etc), the electrical provisions for the same shall be adequately backed with

UPS for protection of vehicle and for efficient car park management.

10.8 Solar Photovoltaic Power Generating System

10.8.1 General

Solar energy, which is available in two forms, heat and light, is a renewable and inexhaustible natural resource and can supplement/augment the depleting fossil fuel resources. Greenhouse gases and pollutant emissions which result from fossil fuel generation can also be offset by solar photovoltaic power generation. Most parts of the country receive good solar radiation of 4 to 7 kWh/m² per day and almost 300 sunny days in a year making solar PV system one of the most preferred renewable energy source in the country.

10.8.2 Solar PV power generating system consists of components and subsystems that are used to convert incident solar radiation directly into electrical energy. The energy converter (namely, solar photovoltaic cells which convert solar energy directly into d.c. electric power) does not have moving parts and has a comparatively long lifetime. Also, it can be used in decentralized/distributed mode.

PV cells are made of light-sensitive semiconductor materials that use photons to dislodge electrons to drive an electric current. The available cell technology used in construction of solar PV is single crystal or mono-crystalline silicon/poly-crystalline or multi-crystalline silicon/amorphous thin film. Individual PV cells are interconnected to form a PV module. This takes the form of a panel for easy installation.

The electrical parameters of the input of a subsystem should be compatible with the output electrical parameters of a preceding subsystem(s).

Most solar PV systems can be mounted on a building or installed on ground. For buildings, they are either mounted on the roof or integrated into the building facade (BIPV).

10.8.3 Types of Solar PV Generating System

When photovoltaic modules are exposed to sunlight, they generate electricity in d.c. waveform. A d.c./a.c inverter then converts the d.c into a.c. or stabilizes d.c. for further distribution. The PV power generating systems can broadly be classified into two categories, namely, stand-alone (with a.c. output or with d.c. output) and grid connected system (see Fig. 10).

10.8.3.1 Stand alone solar PV system (see Fig. 11)

Stand alone solar PV generating system is an independent power production system that is not connected to the grid and can thus be designed free from grid code requirements. This system is also known

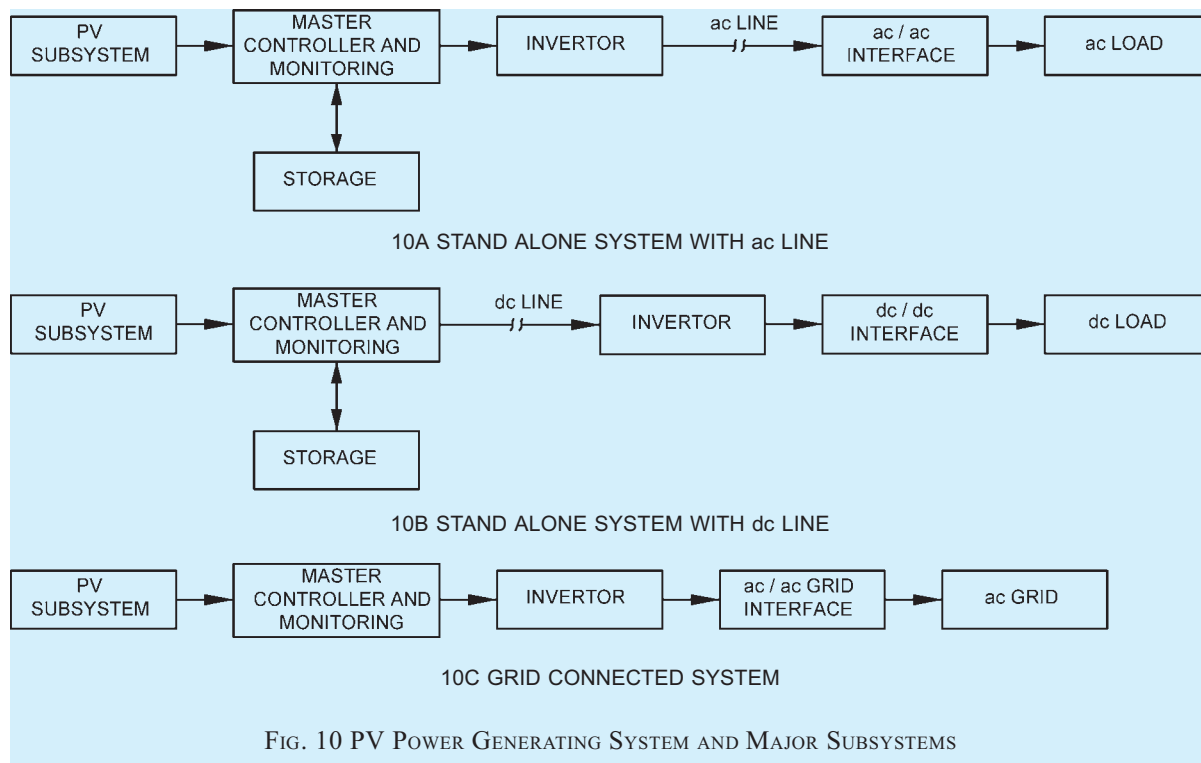

FIG. 10 PV POWER GENERATING SYSTEM AND MAJOR SUBSYSTEMS

as off-grid system. Off-grid solar PV systems are applicable for areas where there is no available power grid, such as remote villages, forests, off-shore islands, ships. But they may also be installed within the city in situations where it is inconvenient or too costly to tap electricity from the power grid.

An off-grid solar PV system needs deep cycle rechargeable batteries, such as lead-acid, nickel-cadmium or lithium-ion batteries to store electricity for use under conditions where there is little or no output from the solar PV system, such as during the night.

10.8.3.2 Grid connected solar PV system (see Fig. 12)

A grid connected solar PV generating system is interconnected with an existing electric power grid, subject to grid requirements. This system is also known as grid-tied system. A building has two parallel power supplies, one from the PV solar system and the other from the power grid. The combined power supply feeds all the loads connected to the main a.c. distribution board. The ratio of solar PV supply to power grid supply varies, depending on the size of the solar PV system. Whenever the solar PV supply exceeds the building's current demand, excess electricity is exported into the grid. When there is no sunlight to generate PV electricity at night, the power grid will feed all the building's demand. A grid-connected system can be an effective way to reduce dependence on utility power during the day, increase renewable energy production, and improve the environment.

10.8.4 When designing solar PV system, care should be taken to address design aspects relating to earthing, short circuit protection, lightning protection and switching control. This shall be done in accordance with Part 8 'Solar Photovoltaic (PV) Power Supply Systems' of National Electrical Code, 2011. Earthing and lightning protection of solar PV systems shall be done in accordance with the procedure laid down in **8** and **11**, respectively.

10.9 Aviation Obstacle Lights

High-rise buildings and structures such as chimneys and towers are potential hazards to aircraft. The provision of aviation obstacle lights (AOL) on tall buildings/structures is intended to reduce hazards to aircraft by indicating their presence. AOLs, low, medium or high intensity obstacle lights, or a combination of such lights, shall be provided on buildings of different heights as per the requirements of Annex 14 to the Convention on International Civil Aviation, Volume I Aerodrome Design and Operations, International Civil Aviation Organization (ICAO). A general arrangement of AOLs in case of group of buildings is given in Fig. 13.

11 LIGHTNING PROTECTION OF BUILDINGS

11.1 Basic Considerations For Protection

11.1.1 There are no devices or methods capable of modifying the natural weather phenomena to the extent that they can prevent lightning discharges. Lightning

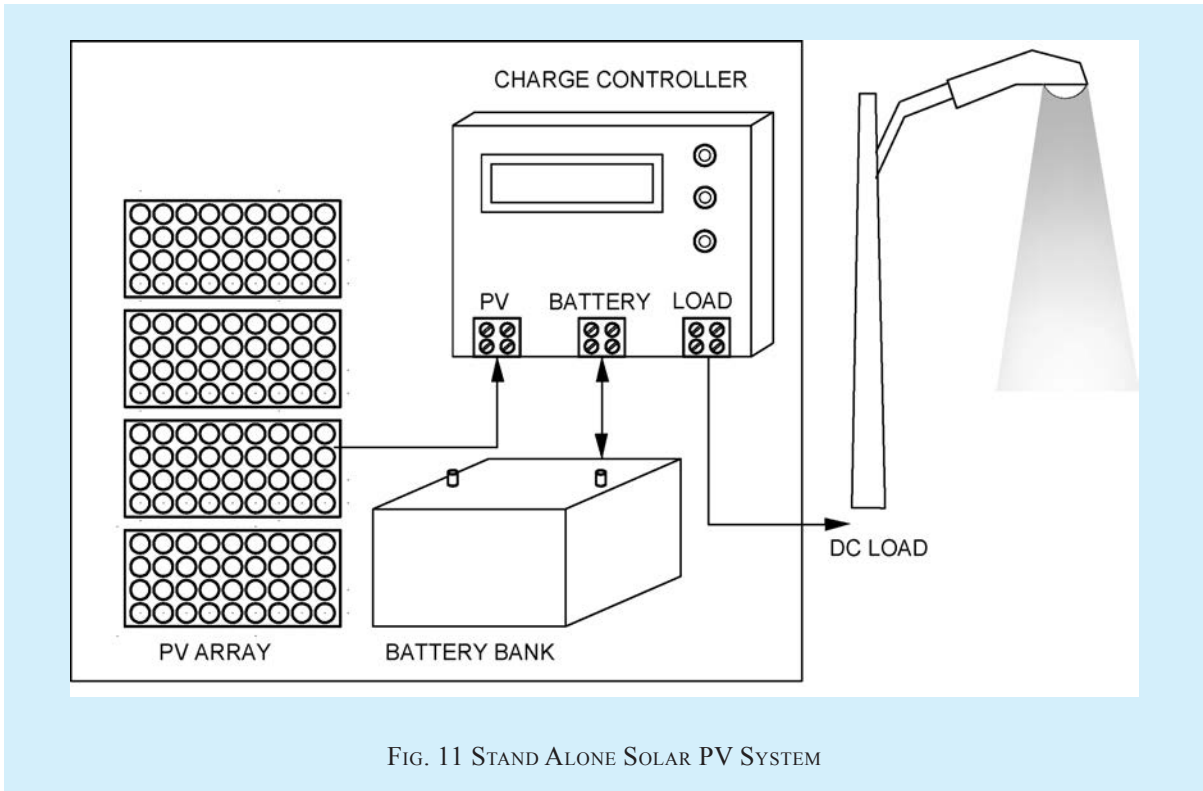

FIG. 11 STAND ALONE SOLAR PV SYSTEM

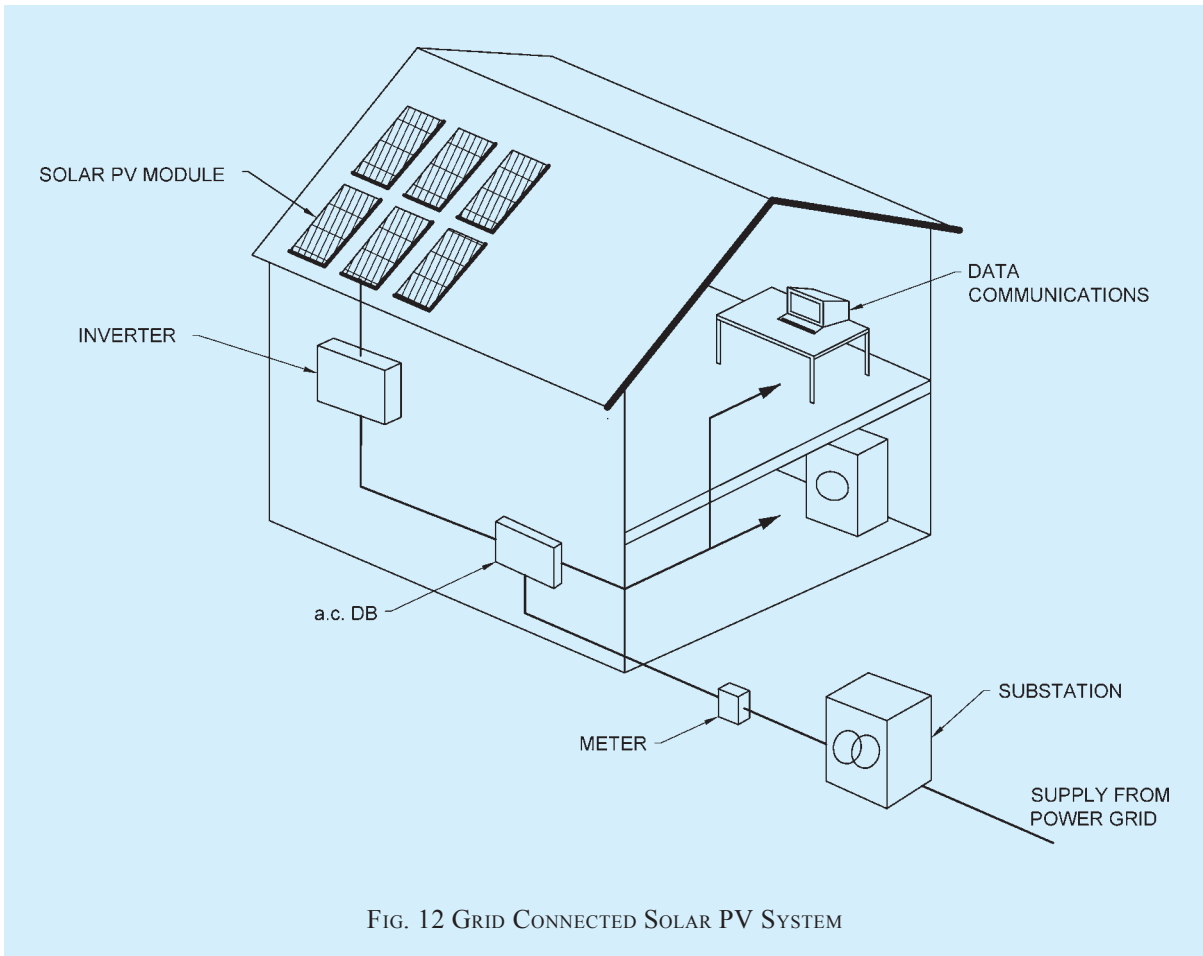
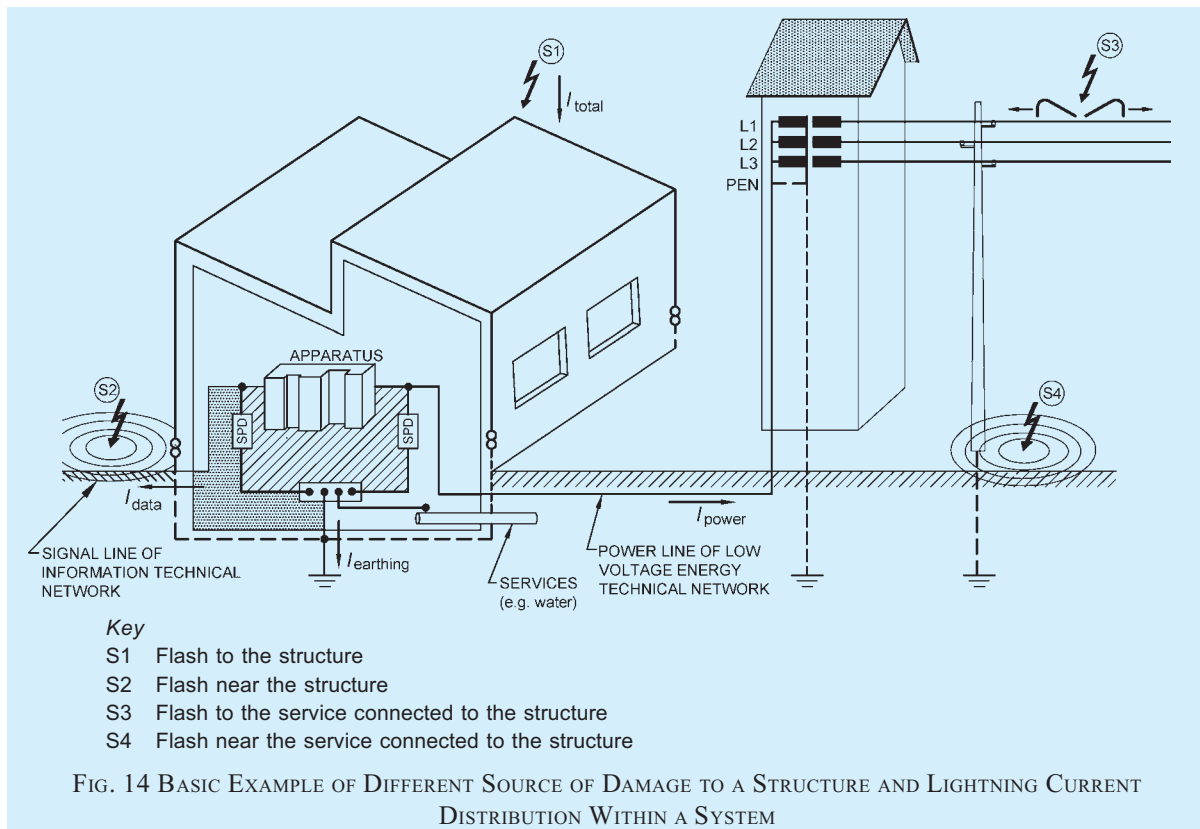
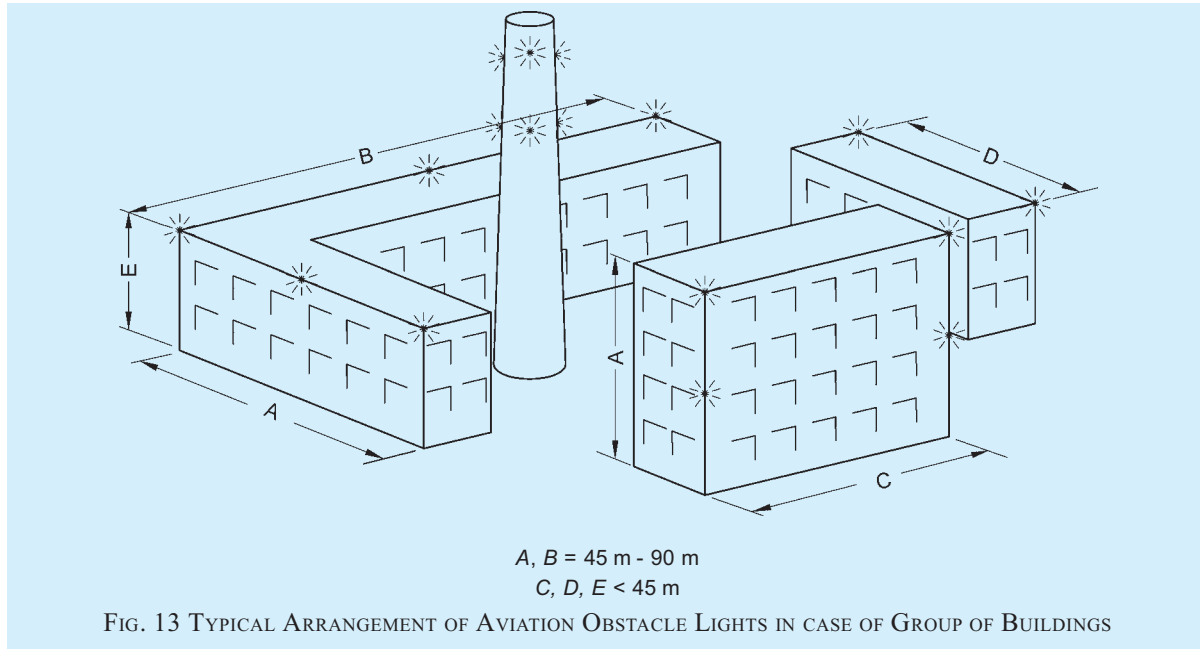

FIG. 12 GRID CONNECTED SOLAR PV SYSTEM

flashes to, or nearby, structures (or lines connected to the structures) are hazardous to people, to the structures themselves, their contents and installations as well as to lines (see Fig. 14). Lightning protection measures therefore become essential. Lightning protection systems are methods to divert the effects of lightning discharges away from the buildings, its occupants and sensitive equipment housed in the building, including

from the necessary connections from public systems to the building. Lightning discharges are of very high energy and can have devastating effects depending on the path of its discharge. Lightning strike is not predictable and is a random phenomenon both from the aspect of its occurrence and intensity or the energy discharge. Protection systems have been developed purely on laboratory behaviour of simulated lightning



strikes and methods of containing them or diverting them to safe paths with least damage. At the same time it is necessary to understand that lightning possibly causes the maximum loss of life to human beings and animals due to its unpredictability, lack of forewarning and protection systems only provide a means of diversion of lightning discharges to safe paths.

Lightning protection systems may be installed to avoid accidents, severe injuries and (may be even) deaths of humans and animals due to direct or indirect lightning. In many cases, the need for protection may be self-evident, for example:

- a) where the area is one in which lightning strokes are prevalent;
- b) where large numbers of people congregate, such as, sports, cultural, assembly buildings;
- c) where there are very tall, complex or isolated structures;
- d) where there are structures of historic or cultural importance;

- e) structures with inherent explosive risks; for example, explosives factories, stores and dumps and fuel tanks;
- f) where essential public services are concerned (as lightning may lead to power outages and unplanned interruptions of production processes); and
- g) where there is wide use of electrical and electronic equipment/ components that are sensitive to the effects of lightning (in industry, ICT enabled buildings, transportation and communication).

11.2 The maximum values of lightning current parameters for the different lightning protection levels (LPL) are given below and are used to design lightning protection components (for example, cross-section of conductors, thickness of metal sheets, current capability of SPDs, separation distance against dangerous sparking) and to define test parameters simulating the effects of lightning on such components {see good practice [8-2(46)] for details}:

<i>First positive impulse</i>			<i>LPL</i>			
Current parameters	Symbol	Unit	I	II	III	IV
Peak current	<i>I</i>	kA	200	150	100	
Impulse charge	<i>Q_{Short}</i>	C	100	75	50	
Specific energy	<i>W/R</i>	MJ/?	10	5.6	2.5	
Time parameters	<i>T₁/T₂</i>	µs/µs	10/350			
<i>First negative impulse</i> ¹⁾			<i>LPL</i>			
Current parameters	Symbol	Unit	I	II	III	
Peak current	<i>I</i>	kA	100	75	50	
Average steepness	<i>dl/dt</i>	kA/µs	100	75	50	
Time parameters	<i>T₁/T₂</i>	µs/µs	1/200			
¹⁾ The use of this current shape concerns only calculations and not testing.						
<i>Subsequent impulse</i>			<i>LPL</i>			
Current parameters	Symbol	Unit	I	II	III	IV
Peak current	<i>I</i>	kA	50	37.5	25	
Average steepness	<i>dl/dt</i>	kA/µs	200	150	100	
Time parameters	<i>T₁/T₂</i>	µs/µs	0.25/100			
<i>Long stroke</i>			<i>LPL</i>			
Current parameters	Symbol	Unit	I	II	III	IV
Long stroke charge	<i>Q_{Long}</i>	C	200	150	100	
Time parameter	<i>T_{Long}</i>	s	0.5			
<i>Flash</i>			<i>LPL</i>			
Current parameters	Symbol	Unit	I	II	III	IV
Flash charge	<i>Q_{Flash}</i>	C	300	225	150	

Definitions of impulse current parameters are shown in Fig. 15 {see also good practice [8-2(46)]}.

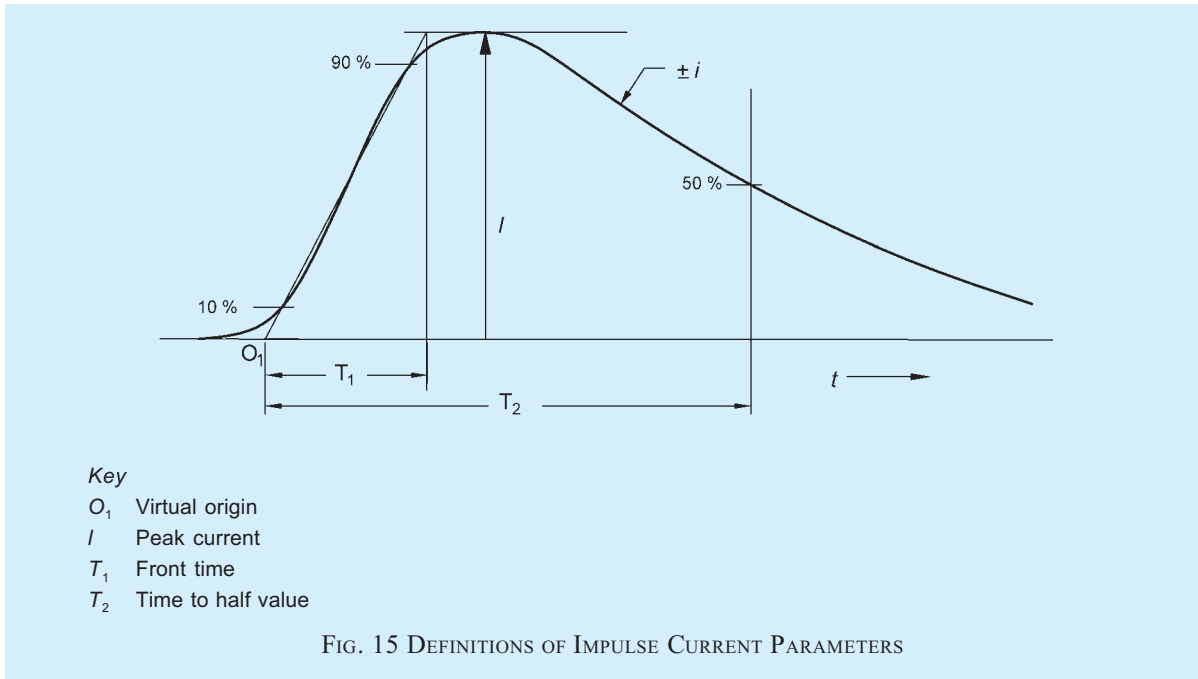

11.3 Risk Assessment

The need for protection, the economic benefits of installing protection measures and the selection of adequate protection measures should be determined in terms of risk assessment. The protection measures should ensure that the calculated risk is less than the tolerable risk (see 11.3.3). Tolerable risk is the maximum value of the risk which can be tolerated. Risk assessment and level of lightning protection required shall be assessed as per the procedure laid down in 11.3.1 to 11.3.4. The good practice [8-2(47)] shall be followed for details.

11.3.1 Typical Values of Tolerable Risk (R_T)

The typical values of tolerable risk (R_T) are given below:

Sl No.	Type of Loss	Tolerable Risk
(1)	(2)	(3)
i)	Loss of human life or permanent injuries	10^{-5} (One injury out of 100 000 strikes)
ii)	Loss of service to the public	10^{-3} (One service loss out of 1 000 strikes)
iii)	Loss of cultural heritage	10^{-4} (One damage out of 10 000 strikes)
iv)	Economic Loss	10^{-3} (One failure out of 1 000 strikes)

11.3.2 Risk Analysis and Lightning Protection Level (LPL)

Risk analysis is done considering the following factors and protection is divided in to four protection levels (LPL I to IV) (see Tables 4 and 5):

- a) *Source of damage* — Such as flashes to a structure, flashes near a structure, flashes to a line, flashes near a line;
- b) *Type of damage* — Injury to living beings by electric shock, physical damage, failure of electrical and electronic systems; and
- c) *Type of loss* — Loss of human life (including permanent injury), loss of service to the public, loss of cultural heritage, loss of economic value (structure, content, and loss of activity).

11.3.3 Risk

Risk (R) is the value of probable average annual loss (humans or goods) due to lightning, relative to the total value (humans or goods) of the structure to be protected. For each type of loss which may appear in a structure or in a service, the relevant risk shall be evaluated for each source and type of damage as given below:

- R_1 : risk of loss of human life;
- R_2 : risk of loss of service to the public;
- R_3 : risk of loss of cultural heritage; and
- R_4 : risk of loss of economic value.

Each risk component, $R_x = N_x \times P_x \times L_x$

where

- N_x = number of dangerous events per annum;
- P_x = probability of damage to a structure; and
- L_x = consequent loss.

NOTE — For annual number of thunderstorm days of various places, 11.8 shall be referred to.

Total risk, R is the sum of various risk components. If $R \leq R_T$, lightning protection is not necessary, where R_T is the tolerable risk.

Besides the need of lightning protection for a structure or for a service, it may be useful to ascertain the economic benefits of installing protection measures in order to reduce the economic loss, L_4 . The assessment of components of risk R_4 for a structure allows the user to evaluate the cost of the economic loss with and without the adopted protection measures.

11.3.4 Lightning Protection Level (LPL)

Based on the risk assessment if protection is necessary, lightning protection is divided into four levels (LPL I to IV) which helps in designing and implementing



protection measures for an economical implementation. LPL I provides the maximum protection and is expensive, whereas, LPL IV provides the least protection and is less expensive. Recommended lightning protection level (LPL) for typical buildings is given in Table 5 for guidance.

Complete system for protection of structures against lightning, including their internal systems and contents, as well as persons, in general consisting of an LPS and SPM shall be installed to avoid damages to structures, accidents, severe injuries and (may be even) deaths of humans due to direct or indirect lightning. Both protection measures should complement each other.

Before proceeding with the detailed design of a lightning protection, the following essential steps should be taken:

- a) Decide whether or not the structure needs protection and, if so, what are the special requirements by making all calculations {see good practice [8-2(47)]}.
- b) Ensure a close liaison between the architect/engineer, the builder, the lightning protective system engineer, and the appropriate

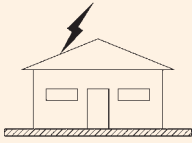
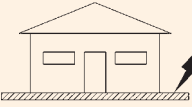
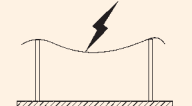
Table 4 Source and Type of Damage and Type of Loss
(Clause 11.3.2)

Sl No.	Point of Strike	Source of Damage	Structure		Service (Metal Lines such as Power, Telephone, etc)	
			Type of Damage	Type of Loss	Type of Damage	Type of Loss
(1)	(2)	(3)	(4)	(5)	(6)	(7)
1)		S1	D1	L1, L4 ²⁾		
			D2	L1, L2, L3, L4	D2	L'2, L'4
			D3	L1 ¹⁾ , L2, L4	D3	L'2, L'4
2)		S2	D3	L1 ¹⁾ , L2, L4		
3)		S3	D1	L1, L4 ²⁾		
			D2	L1, L2, L3, L4	D2	L'2, L'4
			D3	L1 ¹⁾ , L2, L4	D3	L'2, L'4
4)		S4	D3	L1 ¹⁾ , L2, L4	D3	L'2, L'4

¹⁾ Only for structures with risk of explosion, and for hospitals or other structures where failures of internal systems immediately endangers human life.
²⁾ Only for properties where animals may be lost.

authorities throughout the design stages (see also Note).

- c) Agree the procedures for testing and future maintenance {see good practice [8-2(47)]}.

NOTE — Modern buildings with electronic equipment need protection from radiated surges of lightning. To achieve this, structural steel of the building is also sometimes used as a part of lightning protection system {see good practice [8-2(47)]}. In such cases, lightning protection measures shall be included in the structural drawing, particularly for foundation.

Table 5 Recommended LPL for Typical Buildings
(Clause 11.3.4)

Sl No.	Application	LPL
(1)	(2)	(3)
i)	Computer data centres, military applications, high rise hotels/hospitals, nuclear power stations, airports, essential services such as telecom	I
ii)	Low rise hospitals/hotels, ex-zones in the industry and chemical sector, fuel retail outlets/gas stations/compressor stations and similar installations	II
iii)	Schools, banks, residential buildings, temples, churches, mosques, community halls, etc	III/IV

NOTE — Detailed risk assessment should be done before execution.

11.4 Lightning Protection

11.5 Lightning Protection System (LPS)

The main and most effective measure for protection of structures against physical damage is considered to be the lightning protection system (LPS). It usually consists of both external and internal lightning protection systems.

An external LPS which consists of air-termination system, down-conductor system and earthing system {see good practice [8-2(45)] for details} is intended to,

- a) intercept a lightning flash to the structure (with an air-termination system),
- b) conduct the lightning current safely towards earth (using a down-conductor system), and
- c) disperse the lightning current into the earth (using an earth-termination system).

An internal LPS comprises equipotential bonding or a separation distance (and hence electrical insulation) between the external LPS components and other electrically conducting elements internal to the structure.

Both external and internal protection systems should

complement each other. Class of LPS denotes the classification of an LPS according to the lightning protection level for which it is designed. Four classes of LPS (I, II, III and IV) are defined as a set of construction rules, based on the corresponding LPL. Each set includes level-dependent (for example, rolling sphere radius, mesh width etc.) and level-independent (for example, cross-sections, materials, etc) construction rules {see good practice [8-2(47)]}.

Main protection measures against injury to living beings due to touch and step voltages are intended to,

- 1) reduce the dangerous current flowing through bodies by insulating exposed conductive parts, and/or by increasing the surface soil resistivity; and
- 2) reduce the occurrence of dangerous touch and step voltages by physical restrictions and/or warning notices.

The type and location of an LPS should be carefully considered in the initial design of a new structure, thereby enabling maximum advantage to be taken of the electrically conductive parts of the structure. By doing so, design and construction of an integrated installation is made easier, the overall aesthetic aspects can be improved, and the effectiveness of the LPS can be increased at minimum cost and effort.

Access to the ground and the proper use of foundation steelwork for the purpose of forming an effective earth-termination may well be impossible once construction work on a site has commenced. Therefore, soil resistivity and the nature of the earth should be considered at the earliest possible stage of a project. This information is fundamental to the design of an earth-termination system and may influence the foundation design work for the structure.

Regular consultation between LPS designers and installers, architects/civil engineer and builders is essential in order to achieve the best result at minimum cost. If lightning protection is to be added to an existing structure, every effort should be made to ensure that it conforms to the principles of this Code. The design of the type and location of an LPS should take into account the features of the existing structure.

11.5.1 Air-Termination System

11.5.1.1 Air-termination system is a part of an external LPS using metallic elements such as rods, mesh conductors or catenary wires intended to intercept lightning flashes. The probability of penetration by a lightning current on a structure is considerably decreased by the presence of a properly designed air-termination system. Air-termination systems can be composed of any combination of the following elements:

- a) Vertical rods (offers certain angle of protection);
- b) Catenary wires; and
- c) Meshed/Grid conductors.

All types of air-termination systems shall be positioned in accordance with 11.5.1.2. The individual air-terminations rods should be connected together at roof level to ensure current division. Radioactive air-terminals shall not be allowed. Any other kind of air-terminal like dissipation system/ESE air-terminal/CSE air-terminal shall not be acceptable.

11.5.1.2 Positioning

Air-termination components installed on a structure shall be located at corners, exposed points and edges (especially on the upper level of any facades) in accordance with one or more of the following methods {see also Figs. 16 to 20 in conjunction with good practice [8-2(45)]}:

- a) Protection angle method;
- b) Rolling sphere method; and
- c) Mesh method.

The protection angle method is suitable for simple shaped buildings but it is subject to limits of air-termination height indicated in Table 6. The mesh method is a suitable form of protection where plane/pitch roof surfaces are to be protected. The rolling sphere method is suitable in all cases. See good practice [8-2(45)] for details.

11.5.1.3 Roof mounted electrical/electronic equipment (for example, chillers, antennas, cameras and bill boards) need vertical air-termination to avoid direct flashover. All parts of lightning protection should maintain separation distance from these electrical/electronic equipment. Power and data connection to these equipment should have proper Class I and Class II SPD's (see 11.6.5) to avoid failures. Overhead cables such as cable TV lines from one building to the other should be avoided.

11.5.1.4 Unearthed metallic roofs should be avoided. Metallic roofs shall be connected either to steel

reinforcement or to other earthed steel parts of the building satisfying the requirements of number of down-conductors (see 11.5.2). Small buildings with metallic roofs less than 100 m² shall be earthed at least not less than 2 places.

11.5.1.5 Structures of height less than 60 m and more than 60 m

On structures lower than 60 m in height, generally flashes to the side may not occur, hence air-termination protection on sides will not be required (see Fig. 21A).

On structures taller than 60 m, flashes to the side may occur, especially to points, corners and edges of surfaces. In general, the risk due to these flashes is low, but electrical and electronic equipment on walls or outside structures may be destroyed even by lightning flashes with low current peak values.

An air-termination system shall be installed to protect the upper part of tall structures (that is, typically the topmost 20 percent of the height of the structure as far as this part exceeds 60 m in height) and the equipment installed on it. The rules for positioning the air-termination systems on these upper parts of a structure shall meet at least the requirements for LPL IV with emphasis on the location of air-termination devices on corners, edges, and significant protrusions (such as balconies, viewing platforms, etc (see Fig. 21B).

11.5.1.6 Buildings with roof top solar PV and water heaters

Vertical air-terminals are required for protecting roof mounted installations such as solar PV, water heaters, chillers as well as water tanks. Protection angle should be considered as per Table 6. Vertical air-terminals need to be connected to the air-termination mesh/down-conductors. Metal support structure of these installations shall be bonded to the air-termination mesh/down-conductors. Class I/Class II surge protection devices (SPDs) (see 11.6.5) should be installed in the electrical lines to protect the installations inside the building (typically d.c. SPD for solar PV output at inverter or junction box level and a.c. SPD

Table 6 Maximum Values of Mesh Size and Protection Angle Corresponding to the Class of LPS
(Clause 11.5.1.2)

Sl No.	Class of LPS	Mesh Size	Rolling Sphere Radius r m	Protection Angle with respect to Height				
				10 m	20 m	30 m	45 m	60 m
(1)	(2)	(3)	(4)	(5)	(6)	(7)	(8)	(9)
i)	I	5 × 5	20	45	23	← Cannot be used →		
ii)	II	10 × 10	30	54	38	23	← Cannot be used →	
iii)	III	15 × 15	45	62	48	36	3	Cannot be used
iv)	IV	20 × 20	60	65	54	45	34	23

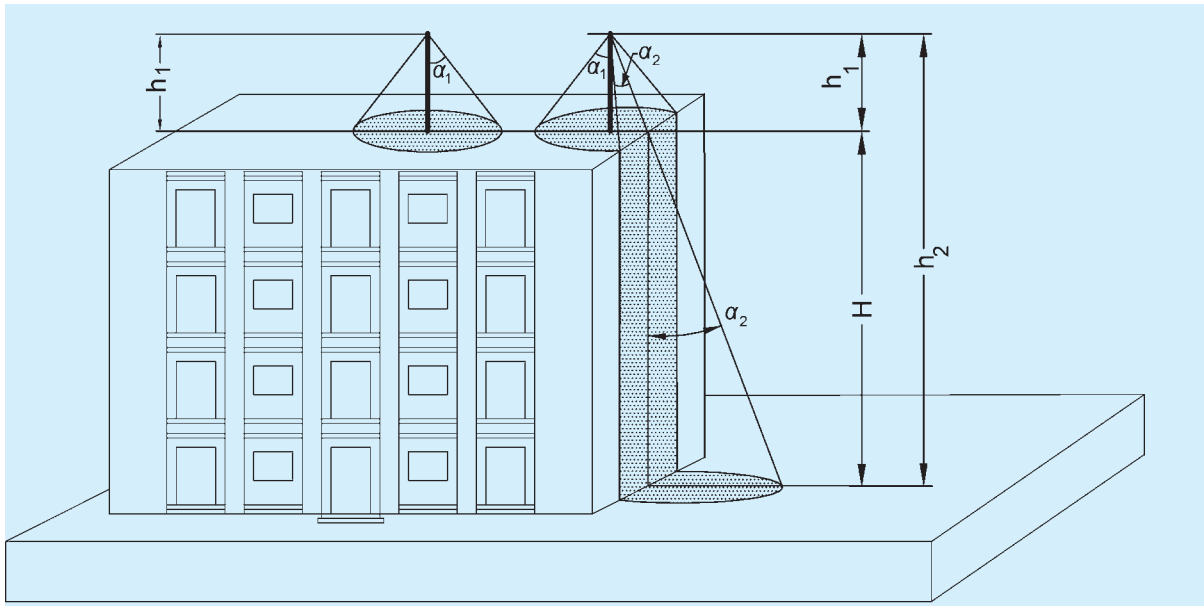

Key

- H Height of the building over the ground reference plane
- h_1 Physical height of an air-termination rod
- h_2 Height of the air-termination rod over the ground ($= h_1 + H$)
- α_1 The protection angle corresponding to the air-termination height, $h = h_1$, being the height above the roof surface to be measured (reference plane)
- α_2 The protection angle corresponding to the height, $h_2 (= H + h_1)$

FIG. 16 PROTECTION ANGLE METHOD OF AIR-TERMINATION DESIGN FOR DIFFERENT HEIGHTS ACCORDING TO TABLE 6

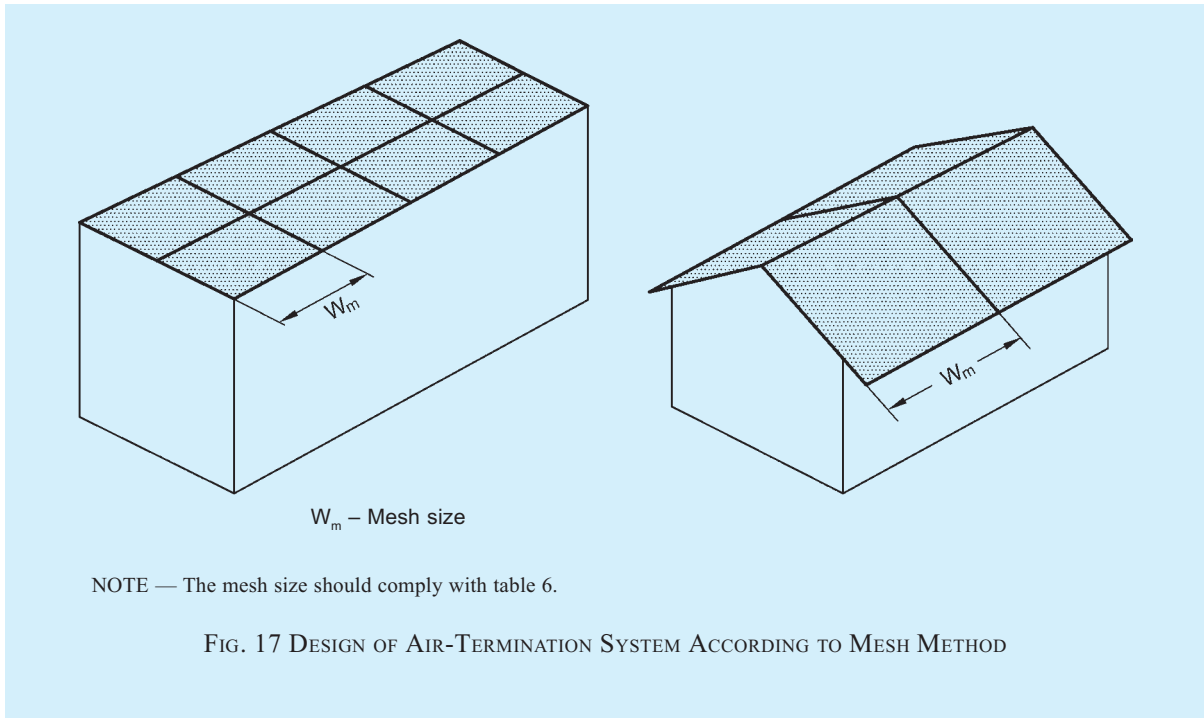

NOTE — The mesh size should comply with table 6.

FIG. 17 DESIGN OF AIR-TERMINATION SYSTEM ACCORDING TO MESH METHOD

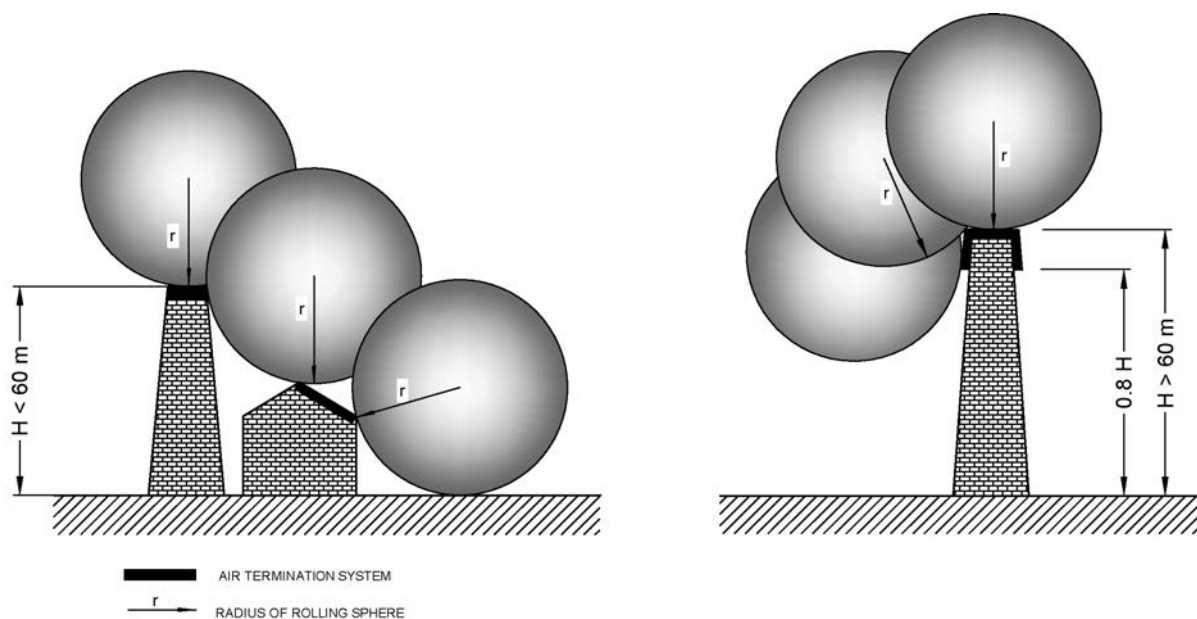

NOTE — The rolling sphere, r should comply with the selected class of LPS (see Table 6).

FIG. 18 DESIGN OF AIR-TERMINATION SYSTEM ACCORDING TO THE ROLLING SPHERE METHOD

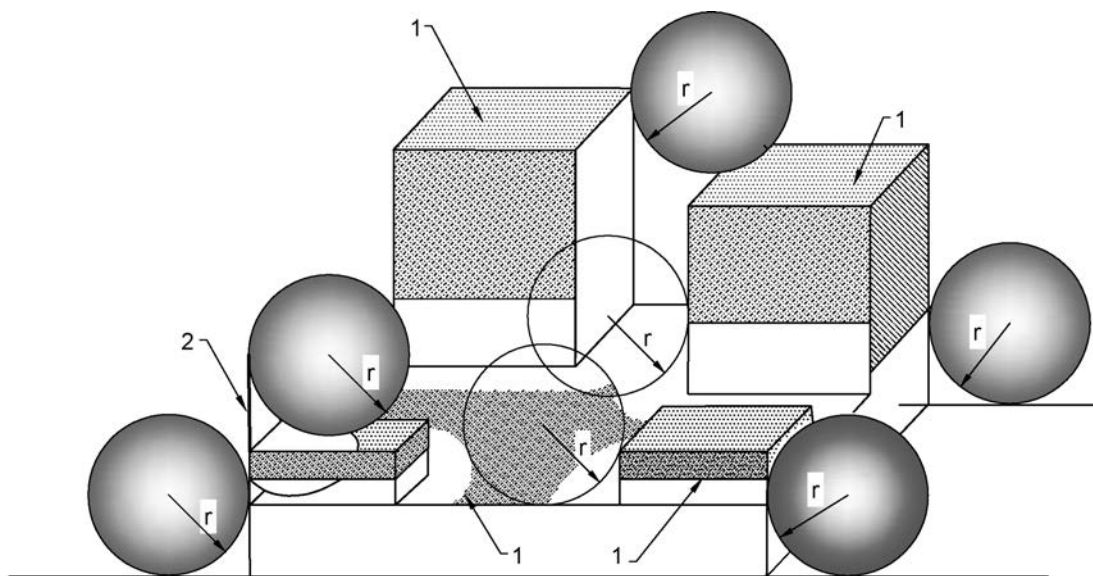

Key

- 1 Shaded areas are exposed to lightning interception and need protection according to Table 6
- 2 Mast on the structure
- r Radius of rolling sphere according to Table 6

NOTE — Protection against side flashes is required {see good practice [8-2(45)] for details}.

FIG. 19 DESIGN OF AIR-TERMINATION CONDUCTOR NETWORK FOR A STRUCTURE WITH COMPLICATED SHAPE

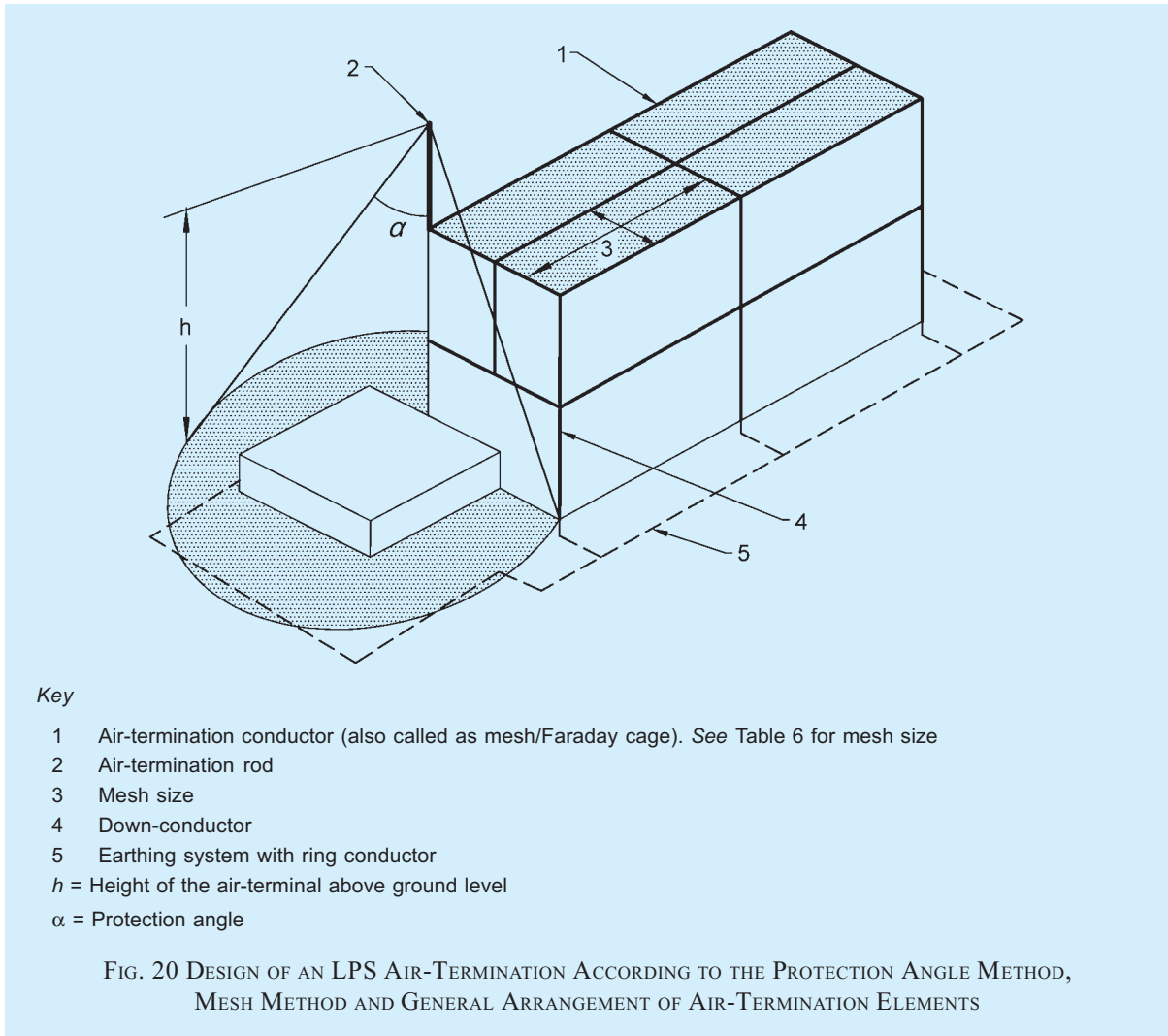

for inverter output and mains input). The roof top PV system or 240 V a.c. water heaters or any other equipment should not pose any safety risk related to lightning protection and protection of overall building may be reviewed by the expert after installation of roof top PV system. Necessary measures may then be required to complete the lightning protection arrangement.

11.5.1.7 Large solar PV power plants/farms

Vertical air-terminals for PV modules based on LPL III/IV connected directly to the frame shall protect against direct lightning impact in case of large solar PV power plants/farms. A design according to rolling sphere method should be done for zone of protection (for example, 1 m rod at 0.5 m height from panel at four corners provides protection to approximately 12 m × 9 m area). Maximum height of the air-termination rod above the panel should be restricted to less than 0.5 m considering the influence of shadow of air-terminal in current generation. To reduce step potential, structures should be interconnected with

underground earth mats/isolating spark gaps, wherever necessary. The short circuit current/expected fault current should be taken into consideration while designing earthing arrangement or while selection of the suitable SPD so as to withstand the same. The provisions should be made to avoid possible d.c. arcing to avoid fire hazards and for the safety of the working personnel.

11.5.1.8 Buildings with roof top telecom towers

The metallic tower itself will act as air-termination. Antennas mounted above these towers (if antenna mounted below to the top of tower by more than 1 m, then no air-terminal is required on top of tower) need air-terminals connected to the main structure. The main structure shall be connected to the air-termination conductors for the balance of the building if available. Two separate down-conductors with a size of minimum 150 mm² should be used in addition to regular down-conductors to make the bonding between tower and ring earthing. In order to avoid uncontrolled flash overs and also to protect equipment, which may be mounted

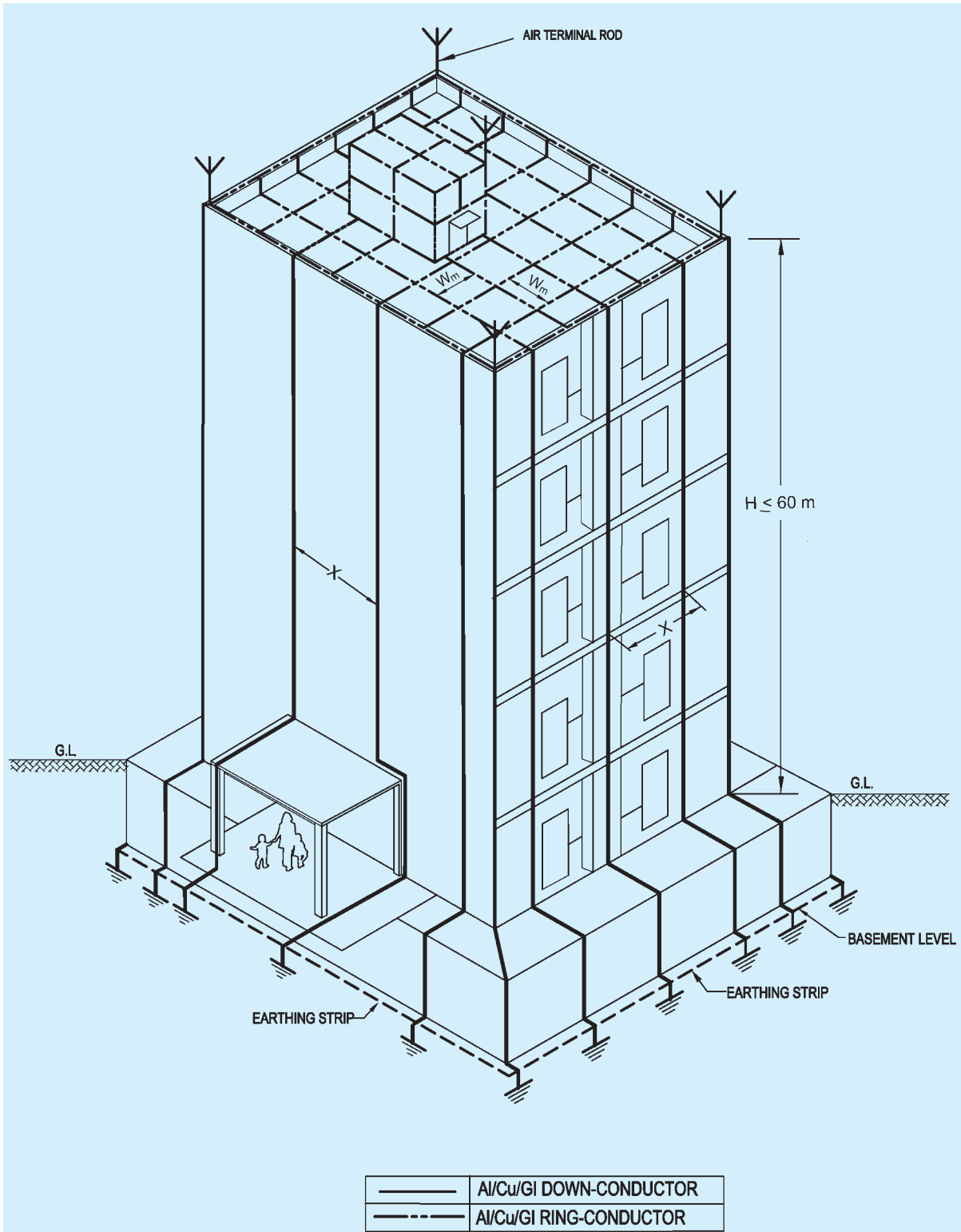

NOTES

- 1 Mesh size, W_m shall be as per Table 6.
- 2 Down-conductor spacing, X, shall be as per Table 7.

21A TYPICAL LIGHTNING PROTECTION SYSTEM FOR BUILDINGS OF HEIGHT, $H \leq 60$ m

FIG 21 — (Continued)

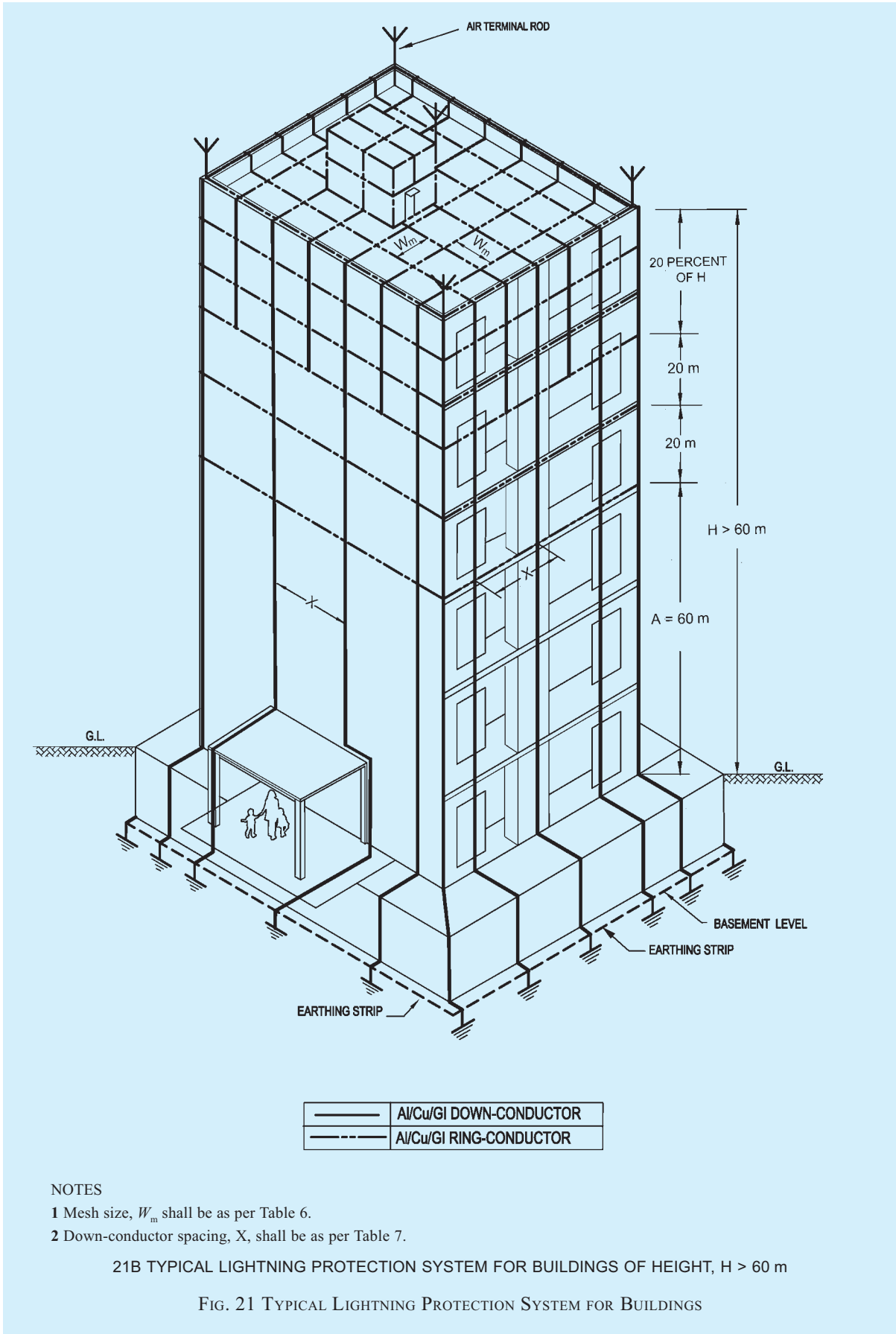

on the tower itself, special cable with increased dielectric strength as down-conductor should be used. Since these down-conductors are shielded, the area of cross-section will be significantly lower than 50 mm² but not less than 16 mm², which is sufficient enough to discharge the lightning current.

Every power, coaxial, data and other metallic lines connected between the telecom installation and the other parts of the building shall be protected with Class 1 and Class 2 SPD. It should be ensured that SPDs during their operation do not impede fire safety.

11.5.1.9 Lightning protection for multi-storeyed car park roofs/helipads

Air-termination studs (see Fig. 22) may be used for lightning protection for multi-storeyed car park roofs/helipads. Air-termination studs used can be connected to the reinforcement steel of a concrete roof. In the case of roofs where a connection to the reinforcement cannot be made, the roof conductors can be laid in the seams of the carriageway slabs and air-termination studs can be located at the mesh joints. The mesh width shall not exceed the value corresponding to the protection class given in Table 6. The persons and vehicles on this parking area are not protected against direct lightning.

11.5.2 Down-conductor System

Down-conductor system is a part of an external LPS intended to conduct lightning current from the air-termination system to the earth-termination system. In order to reduce the probability of damage due to lightning current flowing in the air-termination system, the down-conductors shall be arranged in such a way that from the point of strike to earth,

- a) several parallel current paths exist;

- b) the length of the current paths is kept to a minimum; and
- c) equipotential bonding to conducting parts of the structure is performed.

11.5.2.1 Typical values of the distance between down-conductors are given in Table 7. These values can be used for horizontal ring conductors installed for a tall building more than 60 m height. The minimum number of down-conductors shall be 2 (diagonally opposite to each other) for building with an area less than 100 m².

Table 7 Minimum Distance Between Down-Conductors
(Clause 11.5.2.1)

Sl No. (1)	Class of LPS (2)	Distance m (3)
i)	I	10
ii)	II	10
iii)	III	15
iv)	IV	20

11.5.2.2 Down-conductors shall be installed so that, as far as practicable, they form a direct continuation of the air-termination conductors. It shall be installed straight and vertical such that they provide the shortest and most direct path to earth. The formation of sharp bends and loops shall be avoided. Every down-conductor should be connected to a Type B ring/foundation earthing. Connection of down-conductor to a Type A earthing is allowed only in case of space constraints or existing buildings, where installation is difficult.

11.5.2.3 While routing the down-conductors, separation distance need to be calculated based on good practice [8-2(45)] and maintained from live parts/services.

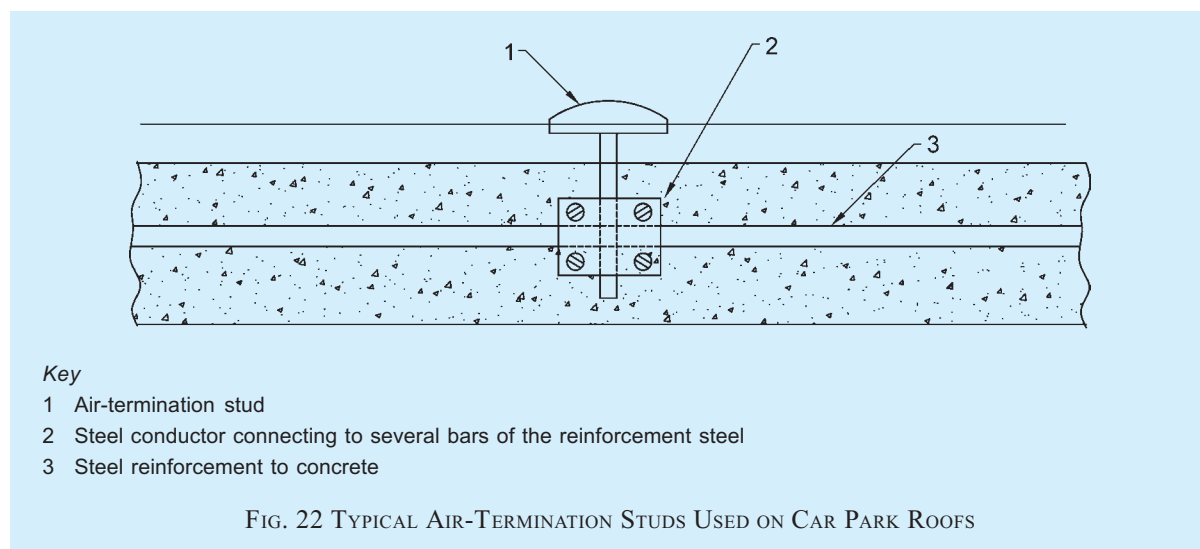

11.5.2.4 Lateral connection of down-conductors at ground level and every 10 m to 20 m of height as a ring conductor as per below table is considered to be good practice. The installation of as many down-conductors as possible, at equal spacing around the perimeter interconnected by ring conductors, reduces the probability of dangerous sparking and facilitates the protection of internal installations {see good practice [8-2(45)]}. This condition is fulfilled in metal framework structures and in reinforced concrete structures in which the interconnected steel is electrically continuous.

11.5.2.5 Routing of down-conductors (insulated or uninsulated) through electrical and other service shafts are not allowed as it can create fire and explosion during lightning.

11.5.2.6 Separation distance is the distance required between air-terminals/lightning down-conductor and any conductive/metallic/electrical/ electronic part of a building to avoid uncontrolled flashover. Separation distance (*S*), in m should be calculated as per the following formula:

$$S = \frac{K_i \times K_c \times l}{K_m}$$

where

- K_i = depends on the selected LPL (see Table 8);
- K_m = depends on the electrical insulation material (see Table 9);
- K_c = depends on the partial lightning current flowing on the air-termination and the down-conductor (see Table 10); and
- l = length, in m along the air-termination and the down-conductor from the point where the separation distance is to be considered, to the nearest equipotential bonding point or the earth-termination.

11.5.2.6.1 Cable with increased dielectric strength and tested for lightning current discharge may be used to avoid specific separation distance to live parts of the building {see good practice [8-2(45)]}.

11.5.2.7 The down-conductor shall be supported on structure like column at every 1 m using suitable clamps or connectors or exothermic welding. The clamps or connectors or exothermic welding shall be tested for the lightning current as per selected LPL. Reference may be made to table given below and good practice [8-2(45)] for supporting details:

<i>Sl No.</i>	<i>Arrangement</i>	<i>Fixing Centres for Tape, Stranded and Soft Drawn Round Conductors</i>	<i>Fixing Centres for Round Solid Conductors</i>
		mm	mm
(1)	(2)	(3)	(4)
i)	Horizontal conductors on horizontal surfaces	1 000	1 000
ii)	Horizontal conductors on vertical surfaces	500	1 000
iii)	Vertical conductors from the ground to 20 m	1 000	1 000
iv)	Vertical conductors from 20 m and thereafter	500	1 000

NOTES

- 1 This table does not apply to built-in type fixings, which may require special considerations.
- 2 Assessment of environmental conditions (that is, expected wind load) should be undertaken and fixing centres different from those recommended may be found to be necessary.

11.5.2.8 At the structures, which cannot be punctured for holding the down-conductors, like tin roofs, glass structures, etc, the down-conductors should be supported with adhesive type clamps tested for weather durability and for withstanding lightning currents as per selected LPL.

11.5.2.9 The wind speed shall be taken into account while mounting the air-termination and down-conductor system {see good practice [8-2(45)]}.

11.5.3 Earth-termination System

Earth-termination system is a part of an external LPS which is intended to conduct and disperse lightning current into the earth. When dealing with the dispersion of the lightning current (high frequency behaviour) into

the ground, whilst minimizing any potentially dangerous over-voltages, the shape and dimensions of the earth-termination system are the important criteria. In general, a low earthing resistance (if possible lower than 10 ohm when measured at low frequency) is recommended. From the viewpoint of lightning protection, a single integrated structure earth-termination system is preferable and is suitable for all purposes (that is, lightning protection, power systems and telecommunication systems).

Type A earth-termination comprising of vertical/horizontal conductor or Type B earth-termination comprising of ring earthing/foundation earthing shall be used satisfying the requirements of this Code as well as good practice [8-2(45)].

**Table 8 Isolation of External LPS —
Approximated Values of Coefficient, K_c**
(Clause 11.5.2.6)

Sl No.	Number of Down-conductors, n	K_c
(1)	(2)	(3)
i)	1 (only in case of an isolated LPS)	1
ii)	2	0.66
iii)	3 and more	0.44

NOTE — Values of Table 8 apply for all Type B earthing arrangements and for Type A earthing arrangements, provided that the earth resistance of neighbouring earth electrodes do not differ by more than a factor of 2. If the earth resistance of single earth electrodes differ by more than a factor of 2, $K_c = 1$ is to be assumed.

Table 9 Isolation of External LPS — Values of Coefficient, K_i
(Clause 11.5.2.6)

Sl No.	Class of LPS	K_i
(1)	(2)	(3)
i)	I	0.08
ii)	II	0.06
iii)	III and IV	0.04

Table 10 Isolation of External LPS — Values of coefficient, K_m
(Clause 11.5.2.6)

Sl No.	Material	K_m
(1)	(2)	(3)
i)	Air	1
ii)	Concrete, bricks, wood	0.5

NOTES
 1 When there are several insulating materials in series, it is a good practice to use the lower value for K_m .
 2 In using other insulating materials, construction guidance and the value of K_m should be provided by the manufacturer.

11.5.3.1 Type A earthing

Length of the earth electrode depends on the soil resistivity and class of LPS {see [8-2(45)] for details and Table 11 for vertical earth electrode}. For Type A, minimum number of earth electrodes should be 2.

11.5.3.2 Type B earthing

This type of arrangement comprises either a ring conductor external to the structure to be protected, in contact with the soil for at least 80 percent of its total length, or a foundation earth electrode. Such earth electrodes may also be meshed. For the ring earth

Table 11 Minimum Length of Vertical Earth Electrode
(Clause 11.5.3.1)

Sl No.	Class of LPS	Typical Length of Each Vertical Earth Electrode Based on Soil Resistivity m			
		Up to 500 Ω -m	1 000 Ω -m	2 000 Ω -m	3 000 Ω -m
(1)	(2)	(3)	(4)	(5)	(6)
i)	I	2.5	10	25	40
ii)	II	2.5	5	15	25
iii)	III	2.5	2.5	2.5	2.5
iv)	IV	2.5	2.5	2.5	2.5

electrode (or foundation earth electrode), the area enclosed by the ring earth electrode (or foundation earth electrode) shall be not less than the value of Type A earthing as given in Table 11 {see also [8-2(45)]}.

11.5.3.3 In structures where only electrical systems are provided, a Type A earthing arrangement may be used, but a Type B earthing arrangement is preferable. In structures with electronic systems, a Type B earthing arrangement is recommended.

11.5.3.4 In industrial and commercial structures, the ring earth electrode around the structure or the ring earth electrode in the concrete at the perimeter of the foundation, should be integrated with a meshed network under and around the structure, having a mesh width of typically 5 m. This greatly improves the performance of the earth-termination system. If the basement's reinforced concrete floor forms a well-defined interconnected mesh and is connected to the earth-termination system, typically at every 5 m, the same will also be suitable {see good practice [8-2(45)]}.

11.5.3.5 For buildings without steel reinforced foundation (brickwork/stones) a Type B earth-termination (ring earthing) shall be installed.

11.5.3.6 Where large numbers of people frequently assemble in an area adjacent to the structure to be protected, further potential control for such areas should be provided. More ring earth electrodes should be installed at distances of approximately 3 m from the first and subsequent ring conductors. Ring electrodes further from the structure should be installed more deeply below the surface, that is, those at 4 m from the structure at a depth of 1 m, those at 7 m from the structure at a depth of 1.5 m and those at 10 m from the structure at a depth of 2 m. These ring earth electrodes should be connected to the first ring conductor by means of radial conductors.

11.5.3.7 For buildings integrating structural steel as down-conductor and earth-termination, earth resistivity

measurements are not required. Proper drawings should be made based on the actual installation and submitted to authorities if necessary. *See also* good practice [8-2(45)].

11.5.4 Use of Natural Components

Natural components are conductive components installed in a building not specifically for lightning protection which can be used to provide the function of one or more parts of the LPS.

Natural components made of conductive materials, which will always remain in/on the structure (for example, interconnected steel-reinforcement, metal framework of the structure, steel roof, metal facade, handrails, etc) should be used as parts of an LPS such as air-termination, down-conductor and earthing, if it satisfies the requirement according to good practices [8-5(44)] and [8-5(45)]. Bonding of different metallic installations in the building should be done to avoid dangerous potential differences which results in flashover. This integrated method is not only economical but does not influence or spoil the aesthetics of the building. It also reduces the failure of electronic equipment inside the building from radiated lightning effects.

In case of natural down-conductors combined with foundation earth electrodes, test joints are not required and earth resistance measurements are not necessary (*see also* 11.5.3.7)

11.5.4.1 Continuity of steelwork in reinforced concrete structures

Steelwork within reinforced concrete structures is considered to be electrically continuous provided that the major part of interconnections of vertical and horizontal bars are welded or otherwise securely connected. Connections of vertical bars shall be welded, clamped or overlapped a minimum of 20 times their diameters and bound or otherwise securely connected. For new structures, the connections between reinforcement elements shall be specified by the designer or installer, in cooperation with the builder and the civil engineer. *See* [8-2(45)] for details.

For structures utilizing steel reinforced concrete (including pre-cast, pre-stressed reinforced units), the electrical continuity of the reinforcing bars shall be determined by electrical testing between the uppermost part and ground level (*see* Fig. 23). The overall electrical resistance should not be greater than 0.2 Ω , measured using test equipment suitable for this purpose. If this value is not achieved, or it is not practical to conduct such testing, the reinforcing steel shall not be used as a natural down-conductor. In this case it is recommended that an external down-conductor be

installed. In the case of structures of pre-cast reinforced concrete, the electrical continuity of the reinforcing steel shall be established between individual adjacent pre-cast concrete units. *See* [8-2(45)] for details.

11.5.4.2 Bonding network

A low impedance bonding network is needed to avoid dangerous potential differences between all equipment inside the building. Moreover, such a bonding network also reduces the magnetic field, thereby reduces the radiated surges inside the building and provides more protection for electrical/electronic equipment {*see* good practice [8-5(48)]}.

This can be realized by a meshed bonding network integrating conductive parts of the structure, or parts of the internal systems, and by bonding metal parts or conductive services at the boundary of each LPZ directly or by using suitable SPDs.

The bonding network can be arranged as a three-dimensional meshed structure with a typical mesh width of 5 m (*see* Fig. 24 and Fig. 25). This requires multiple interconnections of metal components in and on the structure (such as concrete reinforcement, elevator rails, cranes, metal roofs, metal facades, metal frames of windows and doors, metal floor frames, service pipes and cable trays). Bonding bars (for example, ring bonding bars, several bonding bars at different levels of the structure) and magnetic shields of the LPZ shall be integrated in the same way.

Conductive parts (for example, cabinets, enclosures, racks) and the protective earth conductor (PE) of the internal systems shall be connected to the bonding network {*see* good practice [8-5(48)]}.

11.5.5 Materials and Dimensions

Copper and aluminium are recommended for exposed areas on installations required to have a long life. Galvanized steel may be preferred for temporary installations such as exhibition centres. Although it is a common practice to use material in the form of strip for horizontal air-terminations, down-conductors and bonds, it is more convenient to use round material, particularly as it facilitates the making of bends in any plane. If different materials are used in an installation, care should be taken to avoid galvanic corrosion by the use of bi-metallic connectors. *See* Tables 12 to 14 for details.

11.5.6 Protection measures against injury to living beings due to touch voltage and step voltage shall be provided in accordance with good practice [8-2(45)].

11.5.7 Inspection of the LPS shall be done as per the good practice [8-2(45)].

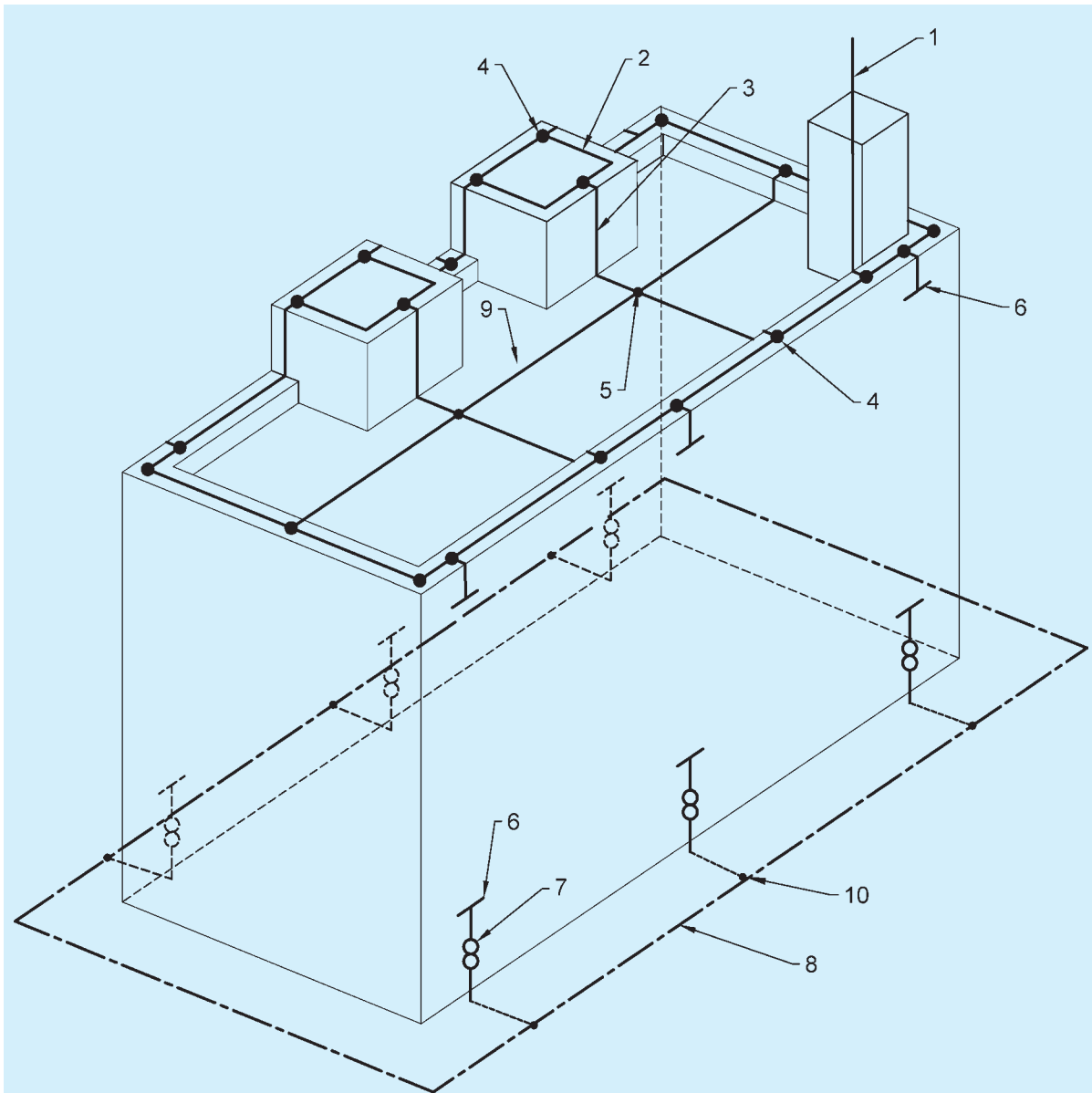

Key

- 1 Air-termination rod
- 2 Horizontal air-termination conductor
- 3 Down-conductor
- 4 T-type joint
- 5 Cross type joint
- 6 Connection to steel reinforcing rods {see E-4.3.3 and E-4.3.6 of good practice [8-2(45)]}
- 7 Test joint
- 8 Type B earthing arrangement, ring electrode
- 9 Flat roof with roof fixtures
- 10 T-type joint — corrosion resistant

NOTE — The steel reinforcement of the structure should comply with available Indian Standards. All dimensions of the LPS should comply with the selected protection level.

FIG. 23 CONSTRUCTION OF EXTERNAL LPS ON A STRUCTURE OF STEEL-REINFORCED CONCRETE USING THE REINFORCEMENT OF THE OUTER WALLS AS NATURAL COMPONENTS

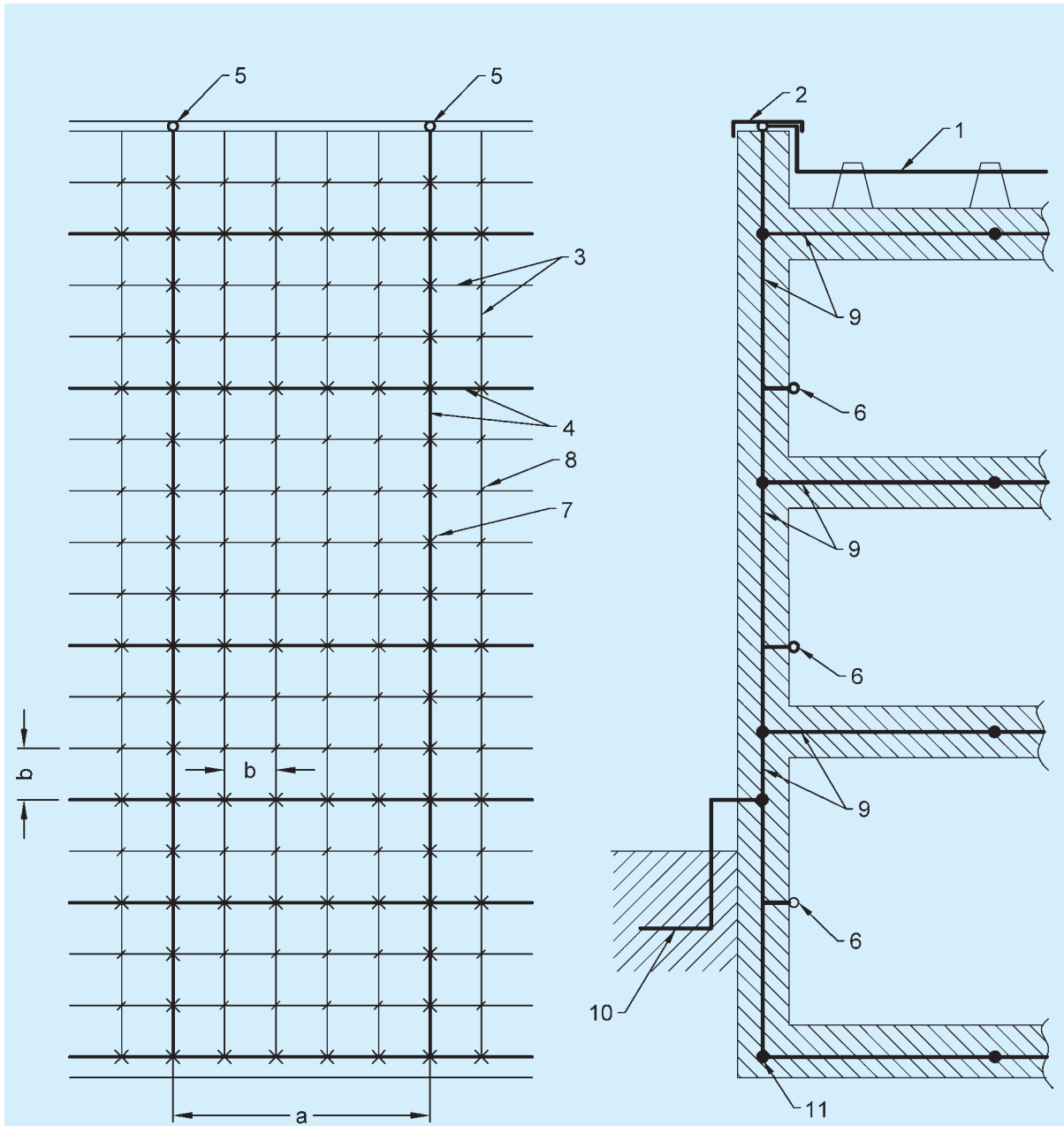

Key

- | | |
|---|---|
| 1 Air-termination conductor | 9 Steel reinforcement in concrete (with super imposed mesh conductors) |
| 2 Metal covering of the roof parapet | 10 Ring earthing electrode (if any) |
| 3 Steel reinforcing rods | 11 Foundation earthing electrode |
| 4 Mesh conductors superimposed on the reinforcement | a Typical distance of 5 m for superimposed mesh conductor |
| 5 Joint of the mesh conductor | b Typical distance of 1 m for connecting this mesh with the reinforcement |
| 6 Joint of the internal bonding bar | |
| 7 Connection made by welding or clamping | |
| 8 Arbitrary connection | |

FIG. 24 UTILIZATION OF REINFORCING RODS OF A STRUCTURE FOR EQUIPOTENTIAL BONDING

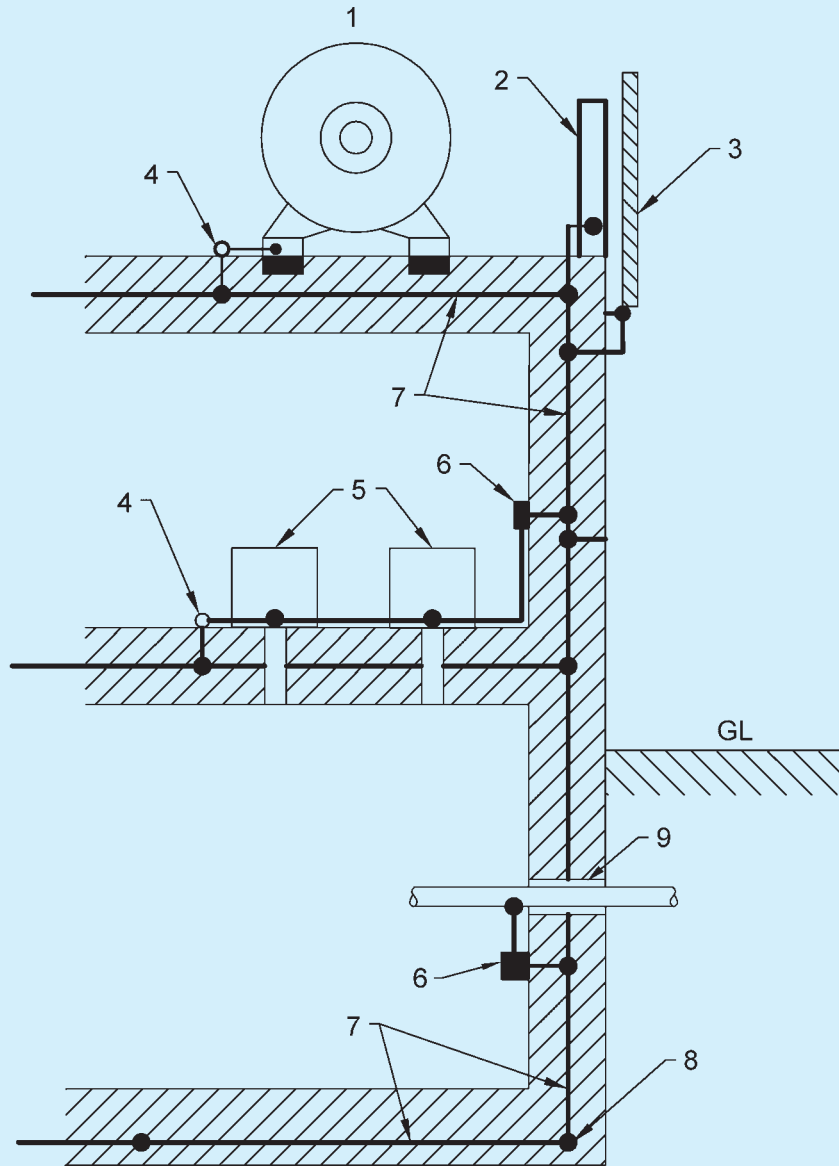

Key

- | | |
|--------------------------------------|---|
| 1 Electric power equipment | 6 Bonding bar |
| 2 Steel girder | 7 Steel reinforcement in concrete (with superimposed mesh conductors) |
| 3 Metal covering of the facade | 8 Foundation earthing electrode |
| 4 Bonding joint | 9 Common inlet for different services |
| 5 Electrical or electronic equipment | |

FIG. 25 EQUIPOTENTIAL BONDING IN A STRUCTURE WITH STEEL REINFORCEMENT

Table 12 LPS Materials and Conditions of Use¹⁾
(Clause 11.5.5)

Sl No.	Material	Use			Corrosion		
		In Open Air	In Earth	In Concrete	Resistance	Increased by	May be destroyed by galvanic coupling with
(1)	(2)	(3)	(4)	(5)	(6)	(7)	(8)
i)	Copper	Solid	Solid	Solid	Good in many environments	Sulphur compounds Organic materials	—
		Stranded	Stranded	Stranded			
		—	As coating	As coating			
ii)	Hot galvanized steel ^{2), 3) and 4)}	Solid	Solid	Solid	Acceptable in air, in concrete and in benign soil	High chlorides content	Copper
		Stranded ⁵⁾		Stranded ⁵⁾			
iii)	Steel with electro-deposited copper	Solid	Solid	Solid	Good in many environments	Sulphur compounds	
iv)	Stainless steel	Solid	Solid	Solid	Good in many environments	High chlorides content	—
		Stranded	Stranded	Stranded			
v)	Aluminium	Solid	Unsuitable	Unsuitable	Good in atmospheres containing low concentrations of sulphur and chloride	Alkaline solutions	Copper
		Stranded					

¹⁾ This table gives general guidance only. In special circumstances more careful corrosion immunity considerations are required.
²⁾ Galvanized steel may be corroded in clay soil or moist soil.
³⁾ Galvanized steel in concrete should not extend into the soil due to possible corrosion of the steel just outside the concrete.
⁴⁾ Galvanized steel in contact with reinforcement steel in concrete may, under certain circumstances, cause damage to the concrete.
⁵⁾ Stranded conductors are more vulnerable to corrosion than solid conductors. Stranded conductors are also vulnerable where they enter or exit earth/concrete positions. This is the reason why stranded galvanized steel is not recommended in earth.

11.6 Protection of Electrical/Electronic Systems within Structures

11.6.1 The internal LPS shall avoid the occurrence of dangerous sparking within the structure to be protected due to lightning current flowing in the external LPS or in other conductive parts of the structure. Dangerous sparking between different parts can be avoided by means of equipotential bonding or electrical insulation between the parts.

Permanent failure of electrical and electronic systems can be caused by the lightning electromagnetic impulse (LEMP) *via*:

- a) Conducted and induced surges transmitted to equipment *via* connecting wiring; and
- b) The effects of radiated electromagnetic fields directly into equipment itself.

Surges to the structure can originate from sources external to the structure or from within the structure itself, and

- 1) surges which originate externally from the structure are created by lightning flashes striking incoming lines or the nearby ground, and are transmitted to electrical and electronic systems within the structure *via* these lines.
- 2) surges which originate internally within the structure are created by lightning flashes

striking the structure itself or the nearby ground. Surges can also originate internally within the structure from switching effects (for example, switching of inductive loads).

The coupling can arise from different mechanisms such as,

- i) resistive coupling (for example, the earth impedance of the earth-termination system or the cable shield resistance); and
- ii) magnetic field coupling (for example, caused by wiring loops in the electrical and electronic system or by inductance of bonding conductors).

In general electrical and electronic systems are subject to damage from a lightning electromagnetic impulse (LEMP). The wave shapes of lightning impulse and surges are given in good practices [8-2(46)] and [8-2(48)]. The lightning current parameters given under **11.2** may also be referred. LEMP protection measures (SPM) need to be provided to avoid failure of internal systems. The design of SPM should be carried out by experts in lightning and surge protection who possesses a broad knowledge of installation practices of lightning protection systems.

11.6.2 Lightning Protection Zone Concept

Protection against LEMP is based on the lightning

Table 13 Material, Configuration and Minimum Cross-Sectional Area of Air-Termination Conductors and Rods, Earth Lead-in Rods and Down-Conductors¹⁾
(Clause 11.5.5)

SI No.	Material	Configuration	Minimum Cross-Sectional Area mm ²
(1)	(2)	(3)	(4)
i)	Copper, Tin plated Copper	Solid tape	50
		Solid round ²⁾	50
		Stranded ²⁾	50
		Solid round ³⁾	176
ii)	Aluminium	Solid tape	70
		Solid round	50
		Stranded	50
iii)	Aluminium alloy	Solid tape	50
		Solid round	50
		Stranded	50
		Solid round ³⁾	176
iv)	Copper coated aluminium alloy	Solid round	50
v)	Hot dipped galvanized steel	Solid tape	50
		Solid round	50
		Stranded	50
		Solid round ³⁾	176
vi)	Copper coated steel	Solid round	50
		Solid tape	50
vii)	Stainless steel	Solid tape ⁴⁾	50
		Solid round ⁴⁾	50
		Stranded	50
		Solid round ³⁾	176

¹⁾ Mechanical and electrical characteristics as well as corrosion resistance properties shall meet the requirements of the IEC 62561 series.
²⁾ 50 mm² (8 mm diameter) may be reduced to 25 mm² in certain application where mechanical strength is not an essential requirement. Consideration should in this case, given to reducing the space between fasteners.
³⁾ Applicable for air-termination rods and earth lead-in rods. For air-termination rods where mechanical stress such as wind loading is not critical, a 9.5 mm diameter, 1 m long rod may be used.
⁴⁾ If the thermal and mechanical considerations are important, then these values should be increased to 75 mm².

protection zone (LPZ) concept. The zone containing systems to be protected shall be divided into LPZs. These zones are theoretically assigned part of space (or of an internal system) where the LEMP severity is compatible with the withstand level of the internal system. Successive zones are characterized by significant changes in the LEMP severity. The boundary of an LPZ is defined by the protection measures employed.

11.6.3 Equipment Protection Principles

11.6.3.1 For protection against the effects of radiated electromagnetic fields impinging directly onto the equipment, SPM consisting of spatial shields and/or shielded lines, combined with shielded equipment enclosures should be used.

11.6.3.2 For protection against the effects of conducted and induced surges being transmitted to the equipment

via connection wiring, SPM consisting of a coordinated SPD system should be used. SPD to be used according to their installation position are as follows:

- a) *At the line entrance into the structure (at the boundary of LPZ 1, for example at the main distribution panel):*
 - 1) SPD tested with I_{imp} (typical waveform 10/350, for example, SPD tested according to class I); and
 - 2) SPD tested with I_n (typical waveform 8/20, for example, SPD tested according to class II).
- b) *Close to the apparatus to be protected (at the boundary of LPZ 2 and higher, for example, at secondary distribution board, or at a socket outlet):*
 - 1) SPD tested with I_n (typical waveform 8/20)

Table 14 Material Configuration and Minimum Dimensions of Earth Electrodes^{1) and 2)}
(Clause 11.5.5)

Sl No.	Material	Configuration	Minimum Dimensions		
			Earth Rod Diameter mm	Earth Conductor mm ²	Earth Plate mm
(1)	(2)	(3)	(4)	(5)	(6)
i)	Copper, Tin plated copper	Stranded		50	
		Solid round	15	50	
		Solid Tape		50	
		Pipe	20		
		Solid plate			500 × 500
		Lattice plate ³⁾			600 × 600
ii)	Hot dipped galvanized steel	Solid round	14	78	
		Pipe	25		
		Solid tape		90	
		Solid plate			500 × 500
		Lattice plate			600 × 600
		Profile	4)		
iii)	Bare steel ⁵⁾	Stranded		70	
		Sold round		78	
		Solid tape		75	
iv)	Copper coated steel	Solid round	14 ⁶⁾	50	
		Solid tape		90	
v)	Stainless steel ⁷⁾	Solid round	15	78	
		Solid tape		100	

1) Mechanical and electrical characteristics as well as corrosion resistance properties shall meet the requirements of IEC 62561 'Lightning protection system components (LPSC)' series.
 2) In case of a type B arrangement foundation earthing system, the earth electrode shall be correctly connected at least every 5 m with the reinforcement steel.
 3) Lattice plate constructed with a minimum total length of conductor of 4.8 m.
 4) Different profiles are permitted with a cross-section of 290 mm² and a minimum thickness of 3 mm, for example, cross profile.
 5) Shall be embedded in concrete for a minimum depth of 50 mm.
 6) 250µm minimum radial copper coating, with 99.9 percent copper content
 7) Chromium ≥ 16 percent, nickel ≥ 5 percent, molybdenum ≥ 2 percent, carbon ≤ 0.08 percent.

for example, SPD tested according to class II); and

- 2) SPD tested with a combination wave (typical waveform 8/20 for example, SPD tested according to class II).

11.6.3.3 Failures of equipment due to electromagnetic fields impinging directly onto the equipment can be considered negligible provided the equipment complies with the relevant radio frequency emission and immunity (EMC) product standards. In general, equipment is required to comply with the relevant EMC product standards therefore SPM consisting of a coordinated SPD system is usually considered sufficient to protect such equipment against the effects of LEMP. For equipment not complying with the relevant EMC

product standards, SPM consisting of a coordinated SPD system as well as additional magnetic shielding measures shall be considered. Coordinated SPD protection should ensure the voltage impulses due to conducted surges are less than the voltage impulse withstanding capacity of the equipment as well as shielding measures should ensure the radiated surges are within the withstanding capacity of the equipment.

11.6.3.4 Design of SPM

SPM can be designed for protection of equipment against surges and electromagnetic fields, as given below. See good practice [8-2(48)] for some examples of SPM using protection measures, such as LPS, magnetic shields and coordinated SPD systems (see 11.6.5).

- a) SPM employing spatial shields and a coordinated SPD system will protect against radiated magnetic fields and against conducted surges. Cascaded spatial shields and coordinated SPDs can reduce the magnetic field and surges to a lower threat level.
- b) SPM employing a spatial shield of LPZ 1 and an SPD at the entry of LPZ 1 can protect equipment against the radiated magnetic field and against conducted surges.

NOTE — The protection would not be sufficient if the magnetic field remains too high (due to low shielding effectiveness of LPZ 1), or if the surge magnitude remains too high (due to a high voltage protection level of the SPD and due to the induction effects onto wiring downstream of the SPD).

- c) SPM using shielded lines, combined with shielded equipment enclosures, will protect against radiated magnetic fields. The SPD at the entry of LPZ 1 will provide protection against conducted surges. To achieve a lower threat level (in one step from LPZ 0 to LPZ 2), a special SPD may be required (for example additional coordinated stages inside) to reach

a sufficient low voltage protection level.

- d) SPM using a coordinated SPD system is only suitable to protect equipment which is insensitive to radiated magnetic fields, since the SPDs will only provide protection against conducted surges. A lower threat surge level can be achieved using coordinated SPDs.

NOTES

1 Solutions in accordance with (a) to (c) are recommended especially for equipment which does not comply with relevant EMC product standards.

2 An LPS in accordance with good practice [8-2(45)] that employs only equipotential bonding SPDs provides no effective protection against failure of sensitive electrical and electronic systems. The LPS can be improved by reducing the mesh dimensions and selecting suitable SPDs, so as to make it an effective component of the SPM.

11.6.4 Equipotentialization of Services to LPS

Equipotentialization is achieved by interconnecting the LPS with structural metal parts, metal installations, internal systems, external conductive parts and lines connected to the structure. See Fig. 26.

Interconnection can be done with bonding conductors,

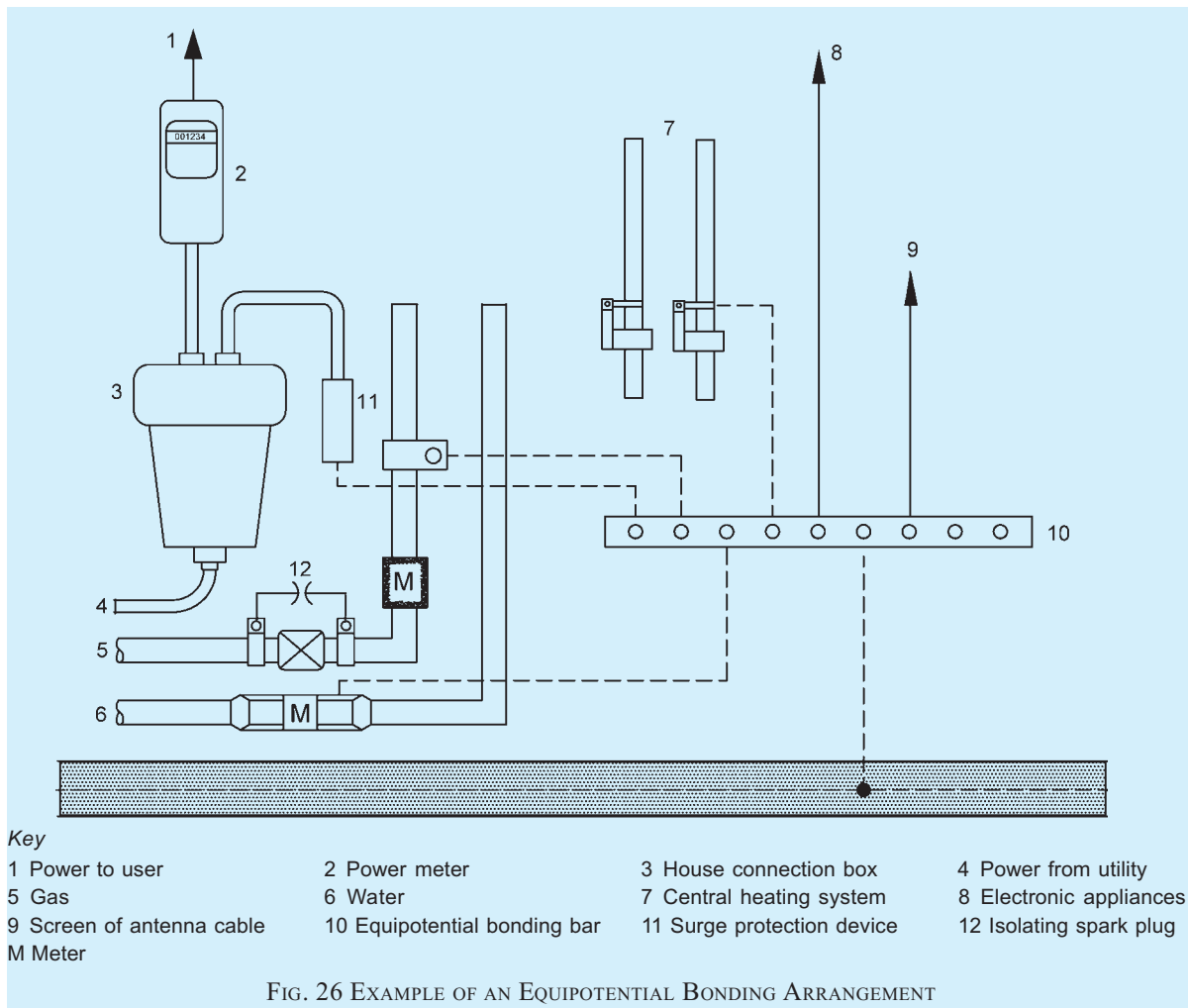

FIG. 26 EXAMPLE OF AN EQUIPOTENTIAL BONDING ARRANGEMENT

where the electrical continuity is not provided by natural bonding or by using surge protective devices (SPD's), where direct connections with bonding conductors is not feasible (for example, installation of SPD's for power, data, telecom lines, etc). It contains at least one non-linear component to ensure perfect equipotential bonding. All SPD's at the service entrance to an installation should be able to divert 10/350 μ S impulse current depending upon selected level of protection. A three phase four wire system should be designed for 50 percent of the I_{imp} of selected LPS and single phase two wire system should be designed for 25 percent of the I_{imp} of selected LPS. The lightning current distribution for three phase four wire system is given in Fig. 27 {see also good practice [8-2(46)]}.

11.6.5 Protection Measures with Surge Protection Devices (SPD's)

11.6.5.1 Lightning surges frequently cause failure of electrical and electronic systems due to insulation breakdown or when over voltages exceed the equipment's common mode insulation level. Power line protection is fundamental, however equal importance should be given to data, communication and instrumentation lines of the equipment that need protection. Equipment is protected, if its rated impulse withstand voltage U_w at its terminals is greater than the surge overvoltage between the live conductors and earth. If not, an SPD shall be installed.

Implementing coordinated SPD's will provide protection against radiated surges for equipment {see good practice [8-2(48)]}. Shielding and routing of power and data lines, bonding of services and various

lightning protection zones (LPZ) {see good practice [8-2(48)]} and earthing also plays major role in protecting electrical and electronic equipment.

SPD's are used to protect under specified conditions, electrical systems and equipment against various over voltages and impulse currents such as lightning and switching surges. SPD shall be selected according to their environmental conditions and the acceptable failure rates of the equipment and the SPD's.

11.6.5.2 Failure of SPDs

Possibility of failure of any line to neutral or neutral to earth connected SPDs should not be ruled out, hence measures should be taken within the SPD for safe failure or withstand in worst conditions. SPD can fail in open or short modes. SPD should not create a fire hazard during failure. Safe failure mode is expected from the SPD.

11.6.5.3 Status indicators

Each SPD should have inbuilt health indicator so as to show if protection is available. SPD should be installed in a way that visual inspection is easily possible. Failed SPD shall be replaced.

11.6.5.4 SPD's for power line need to be installed according to the type of service such as TN, TT, IT, etc. In general, the SPDs connected as per connection diagram given in Fig. 28 (informative) is suitable for TT connections. Reference may be made to relevant Indian Standard for such installations.

11.6.5.5 Selection of SPD's

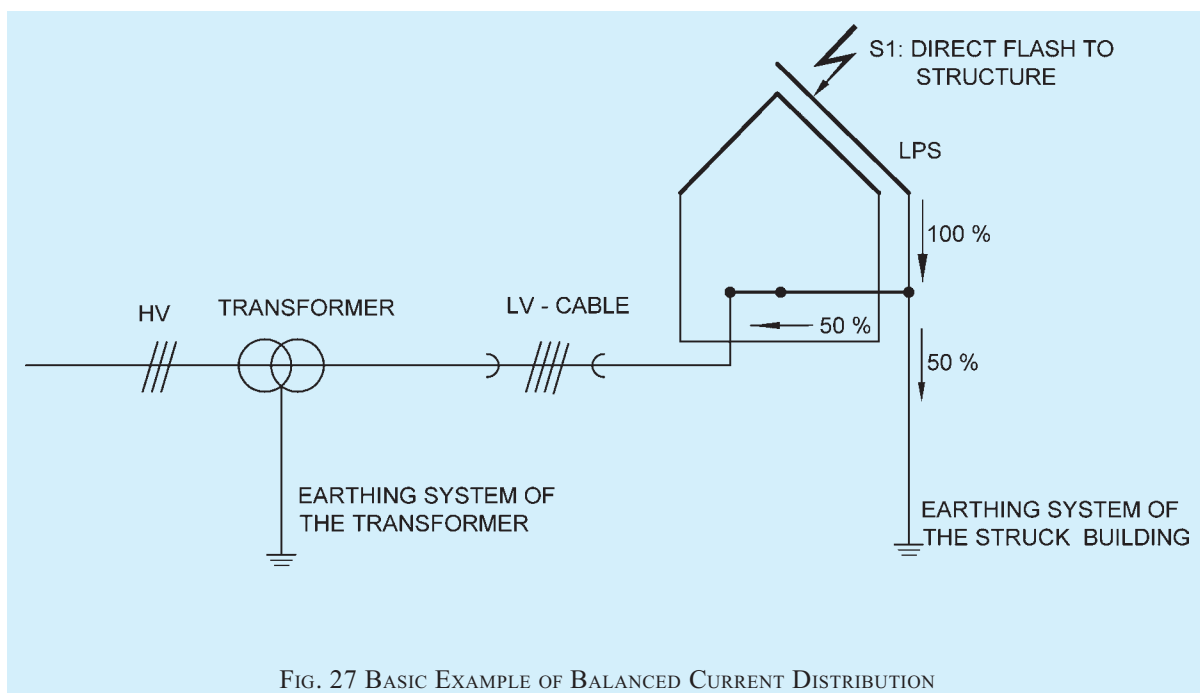
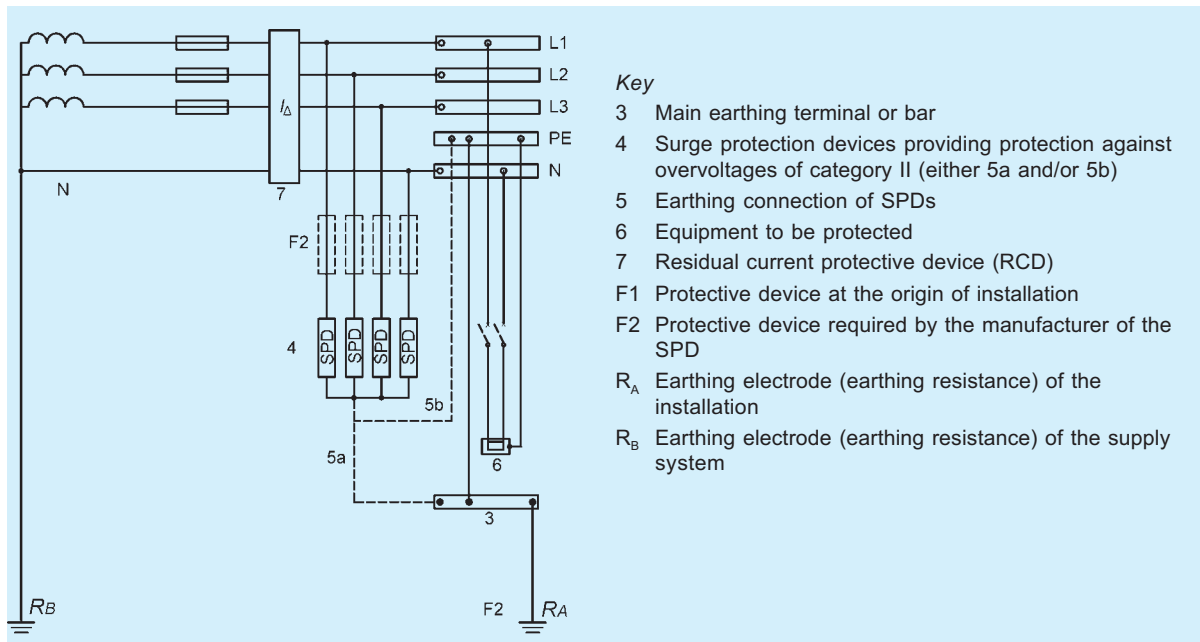
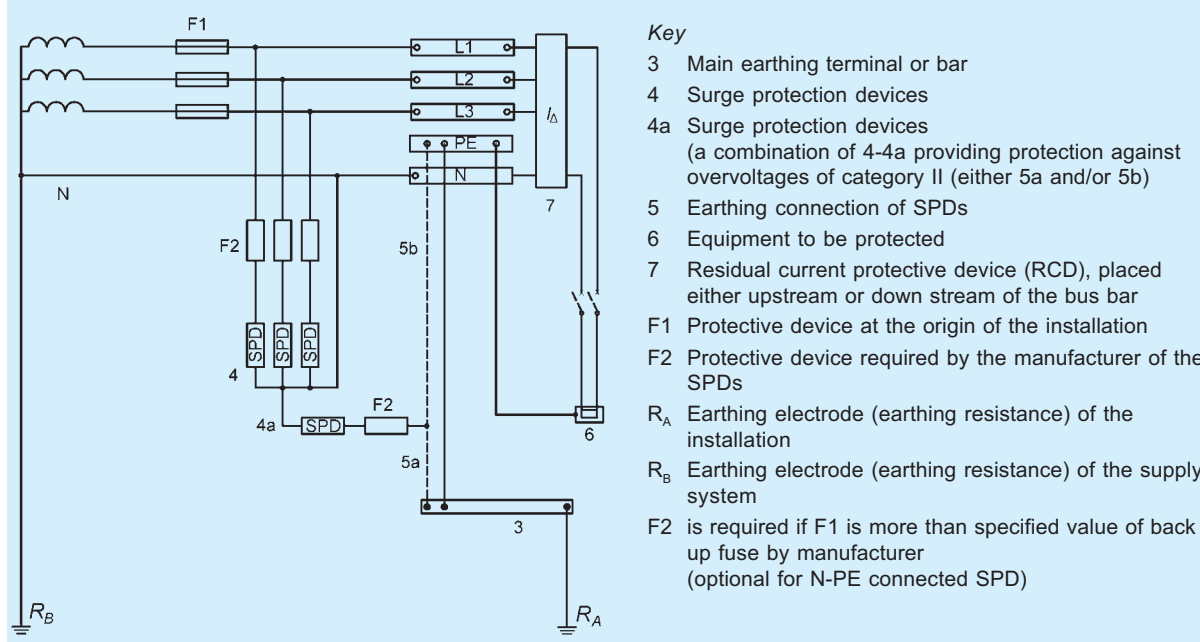

FIG. 27 BASIC EXAMPLE OF BALANCED CURRENT DISTRIBUTION



- Key**
- 3 Main earthing terminal or bar
 - 4 Surge protection devices providing protection against overvoltages of category II (either 5a and/or 5b)
 - 5 Earthing connection of SPDs
 - 6 Equipment to be protected
 - 7 Residual current protective device (RCD)
 - F1 Protective device at the origin of installation
 - F2 Protective device required by the manufacturer of the SPD
 - R_A Earthing electrode (earthing resistance) of the installation
 - R_B Earthing electrode (earthing resistance) of the supply system

28A SPDs ON THE LOAD SIDE OF RCD



- Key**
- 3 Main earthing terminal or bar
 - 4 Surge protection devices
 - 4a Surge protection devices (a combination of 4-4a providing protection against overvoltages of category II (either 5a and/or 5b))
 - 5 Earthing connection of SPDs
 - 6 Equipment to be protected
 - 7 Residual current protective device (RCD), placed either upstream or down stream of the bus bar
 - F1 Protective device at the origin of the installation
 - F2 Protective device required by the manufacturer of the SPDs
 - R_A Earthing electrode (earthing resistance) of the installation
 - R_B Earthing electrode (earthing resistance) of the supply system
 - F2 is required if F1 is more than specified value of back up fuse by manufacturer (optional for N-PE connected SPD)

28B SPDs ON THE SUPPLY SIDE OF RCD

FIG. 28 TYPICAL INSTALLATION OF SPDs IN TT SYSTEM

SPD(s) need to be selected based on the place of installation as well the impulse voltage withstanding capacity of the equipment. I_{imp} and I_n , are test parameters used to categorize Class I and Class II SPD(s). They are related to the maximum values of discharge currents, which are expected to occur at the LPL probability level at the location of installation (LPZ) of the SPD in the system. I_n is associated with Class II tests and I_{imp} is associated with Class I tests.

11.6.5.5.1 If no risk analysis according to good practice [8-2(47)] has been carried out or if the current value of SPD cannot be established, Class I SPDs should be installed with an I_{imp} not less than 12.5 kA (10/350 μ S) for connection according to Fig. 28A or between L to N or PE. For connection according to Fig. 28B, I_{imp} shall not be less than 50 kA (10/350 μ S) between N and PE for three-phase systems and 25 kA (10/350 μ S) between N and PE for single-phase systems. Otherwise the currents shall be considered as per level of protection.

11.6.5.5.2 *Follow current extinguishing capability of the SPD*

Follow current is the short circuit current (rms value) which flows through the SPD when it gets switched on due to lightning strike or surges. The SPD has to restore to normal condition by breaking this short circuit current

before back fuse/switchgears are stressed, in order to retain the availability of the services by the load or to retain the availability of protection in the network. Follow current extinguishing capability and short circuit withstand capacity of SPD shall be as per good practice [8-2(48)].

11.6.5.5.3 Where Class II tested SPD {see good practice [8-2(48)]} are required at or near the origin of installation, the value of I_n shall be not less than 5 kA for connections according to Fig. 28A or between L to N or PE. For Class II tested SPDs connected between neutral and PE for connection in Fig. 28B, I_n shall not be less than 20 kA for three-phase systems and 10 kA for single-phase systems.

11.6.5.5.4 *Voltage protection level of SPD*

The voltage protection level of SPD is the voltage that is finally exposed to the equipment. The voltage protection level (U_p) should be less than the withstand voltage of the equipment. The voltage protection level of the SPD shall be as less as possible to have better protection but it should be ensured that it should not get switched on due to normal voltage variations or during low spark over voltages {see good practice [8-5(48)]}. The values of the withstand voltages of the equipment at various supply voltages is given in Table 15.

Table 15 Rated Impulse Voltage for the Equipment Energized Directly from the Low Voltages Mains
(Clause 11.6.5.5.4)

SI No.	Nominal Voltage of the Supply System ¹⁾ Based on IEC 60038 : 2009 'IEC Standard Voltages' ²⁾		Voltage Line to Neutral Derived from Nominal Voltages a.c. or d.c. up to and Including	Rated Impulse Voltage ³⁾			
	Three Phase	Single Phase		Overvoltage Category ⁴⁾			
	V	V		I	II	III	IV
(1)	(2)	(3)	(4)	(5)	(6)	(7)	(8)
i)			50	330	500	800	1 500
ii)			100	500	800	1 500	2 500
iii)		120-240	150	800	1 500	2 500	4 000
iv)	230/400 277/480		300	1 500	2 500	4 000	6 000
v)	400/690		600	2 500	4 000	6 000	8 000
vi)	1 000		1 000	4 000	6 000	8 000	12 000

¹⁾ See Annex B of IEC 60664-1:2007 'Insulation coordination for equipment within low-voltage systems — Part 1: Principles, requirements and tests' for application to existing different low voltage mains and their nominal voltages.
²⁾ The '/' mark indicates a four-wire three-phase distribution system. The lower value is the voltage line-to-neutral, while the higher value is the voltage line-to-line. Where only one value is indicated, it refers to three-wire, while the higher value is the voltage line-to-line. Where only one value is indicated, it refers to three-wire, three-phase systems and specifies the value line-to-line.
³⁾ Equipment with these rated impulse voltage can be used in installations in accordance with IEC 60364-4-44 'Low-voltage electrical installations — Part 4-44: Protection for safety — Protection against voltage disturbances and electromagnetic disturbances'.
⁴⁾ See 4.3.3.2.2 of IEC 60664-1:2007 'Insulation coordination for equipment within low-voltage systems — Part 1: Principles, requirements and tests' for an explanation of the overvoltage categories.

11.6.5.5.5 The preferred values of voltage protection level of SPDs, U_p is given below (see IEC 61643-11:2011):

- 0.08, 0.09, 0.10, 0.12, 0.15, 0.22, 0.33, 0.4, 0.5, 0.6, 0.7, 0.8, 0.9, 1.0, 1.2, 1.5, 1.8, 2.0, 2.5, 3.0, 4.0, 5.0, 6.0, 8.0 and 10 kV

Hence for protecting a 240 V/415 V connected equipment, selecting a $U_p \leq 1.5$ kV will be a safer choice. The U_p may be tested and certified by a third party as per the laid down test procedures. See Fig. 29 on connection diagram for SPD.

11.6.5.6 For small residential buildings, power line SPD at the mains incoming panel will enhance the life of electronic equipment, such as TV, music system, refrigerators, LED lights, etc.

11.6.5.7 For large buildings, power line SPD is required at incoming panel as well as for sub distribution panels based on the LPZ principle {see good practice [8-5(48)]}.

11.6.5.8 For industrial and commercial buildings, critical and sensitive loads such as drives, PLC's, automation panels, etc require protection with SPD in addition to SPD at incoming power panels and sub-distribution boards. SPDs shall be selected to meet the requirements of relevant LPZs.

11.6.5.9 Lifts, escalators, moving walks and fire panels

shall be protected with SPD in control panels. All electrical and control panels related to safety and security of building shall be protected with appropriate SPDs.

11.6.5.10 SPDs should be installed for outdoor equipment such as CCTV cameras, LED street lights, weighbridges, firefighting systems, roof top solar PV installations, etc. This will ensure availability of the vital services provided by these equipment as and when required.

11.6.5.11 Failure of equipment and chance of fire in electrical installations are more for buildings near tall structures (for example, telecom tower). These buildings should be protected with SPD at power incoming and ring earthing to avoid fire and equipment failure.

11.6.5.12 All SPDs should have status indication to show their healthy state for discharging the lightning current. The possibility of failure of L-N as well as N-PE connected SPD cannot be ignored.

11.6.5.13 The SPD shall be installed at the entrance to ensure perfect bonding to the ground at the time of lightning {see good practice [8-2(44)] and [8-2(48)]}. The let through energy of the protection system shall be less than the energy that equipment can withstand. As per good practice [8-5(48)], the energy coordination method is the best method to ensure the protection of the equipment. The let through energy details of the SPD shall be provided by manufacturer.

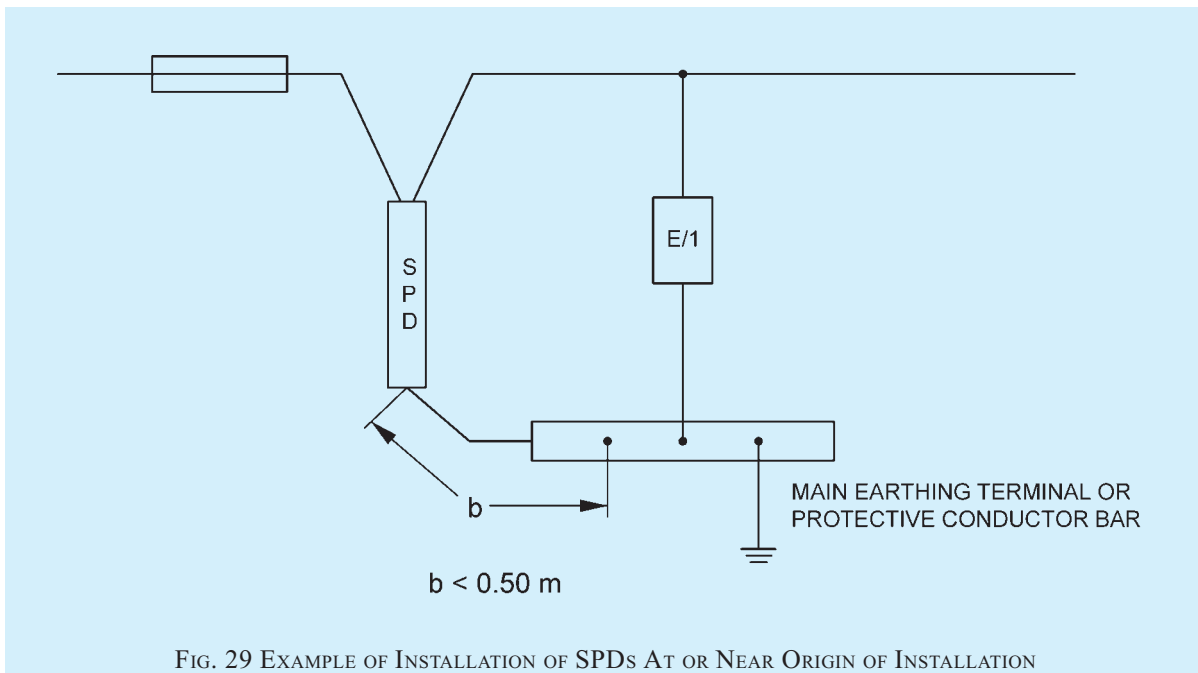

FIG. 29 EXAMPLE OF INSTALLATION OF SPDs AT OR NEAR ORIGIN OF INSTALLATION

11.6.5.14 Maximum continuous operating voltage of the SPD (U_c) should not be less than $1.1 \times U_{\text{nominal}} = 1.1 \times 230 = 253 \text{ V}$; however, neutral disconnect tests are done at much higher voltages (above 440 V) to simulate this condition.

The Class I SPD shall be tested to withstand sustained high voltage of minimum 460 V (L-N) under neutral disconnect condition.

11.6.5.15 Low-voltage SPDs for connection to low-voltage power systems shall be conforming to the accepted standard [8-2(49)].

11.6.5.16 SPDs for data/telecommunication line shall be selected considering following parameters:

- a) Place of installation {see good practice [8-2(48)] for lightning protection zone concept};
- b) Immunity of terminal equipment;
- c) Earthing of the system to be protected (balanced/unbalanced);
- d) Requirement on interface (transmission parameters: voltage, frequency, current); and
- e) Mounting interface.

These SPDs shall be tested as per Table 16.

NOTE — Reference may be made to IEC 61643-21:2000 'Low voltage surge protective devices — Part 21: Surge protective devices connected to telecommunications and signalling networks — Performance requirements and testing methods' for requirements and test methods for SPDs for data/telecommunication line.

Table 16 Voltage and Current Waveforms for Impulse-Limiting Voltage
(Clause 11.6.5.16)

Sl No.	Category	Type of Test	Open-Circuit Voltage ¹⁾	Short-Circuit Current	Minimum Number of Applications	Terminals to be Tested
(1)	(2)	(3)	(4)	(5)	(6)	(7)
i)	A1	Very slow rate of rise	$\geq 1 \text{ kV}$ Rate of rise from $0.1 \text{ kV}/\mu\text{s}$ to 100 kV/s	10 A, $0.1 \text{ A}/\mu\text{s}$, $2 \text{ A}/\mu\text{s}$ $\geq 1000 \mu\text{s}$ (duration)	Not applicable (NA)	X1-C X2-C X1-X2 ²⁾
	A2	AC	Select a test from Table 5 of IEC 61643-21:2000 'Low voltage surge protective devices — Part 21 surge protective devices connected to telecommunications and signaling networks — Performance requirements and testing methods' ¹⁾	Single cycle		
ii)	B1	Slow rate of rise	1 kV 10/1 000	100 A, 10/1 000	300	
	B2		1 kV to 4 kV 10/700	25 A to 100 A 5/300	300	
	B3		$\geq 1 \text{ kV}$ $100 \text{ V}/\mu\text{s}$	10 A to 100 A 10/1 000	300	
iii)	C1	Fast rate of rise	0.5 kV to <2 kV 1.2/50	0.25 kA to < 1 kA 8/20	300	
	C2		2 kV to 10 kV 1.2/50	1 kA to 5 kA 8/20	10	
	C3		$\geq 1 \text{ kV}$ $1 \text{ kV}/\mu\text{s}$	10 A to 100 A 10/1 000	300	
iv)	D1	High energy	$\geq 1 \text{ kV}$	0.5 kA to 2.5 kA 10/350	2	
	D2		$\geq 1 \text{ kV}$	0.6 kA to 2.0 kA 10/250	5	

NOTES

1 For the verification of U_{pp} , one of the above impulse waveform of Category C is mandatory and A, B and D are optional. Unless otherwise specified, apply 5 positive and 5 negative pulses.

2 For impulse reset, select test from Category B, C and D. Unless otherwise specified, apply 3 positive and 3 negative pulses.

3 For impulse durability measurement, one impulse waveform of Category C is mandatory and A1, B and D are optional.

4 Values listed in this table are minimum requirements; other surge current ratings are possible and can also be found in other standards, for example, ITU-T K series — Recommendations.

¹⁾ An open-circuit voltage different from 1 kV may be used. However, it shall be sufficient to operate the SPD under test.

²⁾ X1-X2 terminals shall be tested only if it is required.

11.7 Implementation of Lightning Protection Measures for Typical Buildings

<i>Sl No.</i>	<i>Type of Building</i>	<i>Place</i>	<i>Implementation</i>
(1)	(2)	(3)	(4)
i)	Buildings with no steel reinforced foundation with electricity connection (one or two family private dwellings)	Close to tall structures/trees ¹⁾	SPD and ring earthing connected to the power incoming switchboard earth terminal
		Isolated	Class IV external LPS, SPD ²⁾ and ring earthing
ii)	Buildings with steel reinforced foundation with electricity connection (one or two family private dwellings)	Close to tall structures/trees ¹⁾	SPD ²⁾ and bonding of steel reinforcement to earthing bonding bar ³⁾
		Isolated	Class IV external LPS connected to reinforcement and down-conductor ⁵⁾ (max every 20 m). SPD ²⁾ and bonding ³⁾ of steel reinforcement to earthing bonding bar
iii)	Buildings with steel reinforced foundation with electricity connection (less than 20 m height) [other than those covered in (ii)]	Urban/suburban/rural	Class IV External LPS connected to reinforcement and down-conductor ⁵⁾ (max every 20 m). SPD ²⁾ and bonding ³⁾ of steel reinforcement to earthing bonding bar
iv)	Residential high rise buildings (more than 20 m height) with steel reinforced columns/ pillars	Urban/suburban/rural	
v)	Educational buildings (school/ college/ training) for education or recreation for not less than 20 students	Urban/suburban/rural	Recommended ⁶⁾ LPS as per 11.3. SPD ²⁾ and bonding of steel reinforcement to earthing bonding bar ³⁾ . Additional step/touch potential reduction measures in pathways/play grounds
vi)	Institutional buildings (Hospitals/ Jails)	Urban/suburban/rural	
vii)	Assembly buildings (theatres/ passenger stations (rail/bus/air)/ exhibition halls/religious buildings)	Urban/suburban/rural	
	Assembly buildings (more than 5 000 people) Railway stations/airport/hill stations/mines	Urban/suburban/rural	In addition to LPS as per good practice [8-5(45)], [8-5(46)], [8-5(47)] and [8-5(48)], lightning safety areas shall be declared for the assembly of people during thunderstorm
viii)	Offices, banks, data centers, telephone exchanges, broadcasting stations	Urban/suburban/rural	Recommended ⁶⁾ LPS as per good practice 11.3. SPD ²⁾ and bonding of steel reinforcement to earthing bonding bar ³⁾ . Ring earthing as per 11.5.1 for the safe assembly area.
ix)	Industrial buildings/Storage buildings (without the risk of combustible materials)	Urban/suburban/rural	

<i>Sl No.</i>	<i>Type of Building</i>	<i>Place</i>	<i>Implementation</i>
(1)	(2)	(3)	(4)
x)	Hazardous Buildings (storage and handling of highly flammable or explosive materials, liquids or gases ⁷⁾	Urban/suburban/rural	

¹⁾ Side flashes from trees/tall structures are expected if the building is within 5 m. To reduce the impact of side flash, metal conductors (down-conductors) connected to ring earthing need to be installed near the tall structure.
²⁾ SPD shall be installed in all the incoming services like power, telephone, data , etc.
³⁾ May not be possible for an existing building. Ring earthing is recommended as an alternate. Provision to bond the steel reinforcement to the earthing bus bar shall be provided during the construction of the building using a corrosion resistant metal (such as stainless steel).
⁴⁾ Direction boards towards lightning safe area shall be shown.
⁵⁾ Down-conductor can be avoided, if reinforcement steel is interconnected according to good practice [8 -5(44)].
⁶⁾ *Recommended LPS* — Class of LPS as derived in a risk assessment calculation as per 11.3.
⁷⁾ Lightning protection with insulated materials can avoid safety distance of LPS from these installations.
⁸⁾ The quality of the connectors and other components of the LPS shall be ensured by following tests:
a) Salt mist test;
b) Humid sulphurous atmosphere treatment tests;
c) Electrical tests for lightning current and resistance;
d) *Mechanical strength tests* – tensile strength, minimum elongation test; and
e) Metal compatibility tests.

11.8 Average Number of Thunderstorm Days

For the purpose of risk assessment, annual thunderstorm days in various places are provided in the informal table to be read along with Fig. 30.

12 ELECTRICAL INSTALLATIONS FOR CONSTRUCTION AND DEMOLITION SITES

12.1 General

12.1.1 Electrical hazards are a major cause of serious injury and even death in construction sites. Accidents also cause loss of productivity and destroy the morale of workers. The need to use electricity and electrical/electronic equipment has been constantly increasing. Without these gadgets productivity and quality of work will suffer. Therefore the use of electricity and the use of gadgets has to increase. Such increase requires a proper electrical distribution system in the work site.

12.1.2 To ensure continuous supply of power during the construction activity and maintain productivity, site security, etc, the city power supply may required to be supplemented by on-site standby power generation. Some gadgets require continuity of power supply without interruption, thereby requiring UPS systems. In a typical large construction site there may be a large temporary distribution network combined with more than one source of electricity, which can make the system quite complex from the safety point of view.

12.1.3 Problem may also arise in case of lack of

required training to workers in the safe use of the tools and equipment that they are required to handle in a system with multiple sources of power supply. In case of use of imported equipment which may be manufactured to their own standards, problems may arise, such as, during connection and inter-connection of equipment and tools and mismatch of plugs and sockets.

12.1.4 Practical guidance to employers, designers, manufacturers, importers, suppliers (including hirers), electrical contractors and electricians on eliminating or reducing the risk of electrocution and electric shock to any person is necessary.

12.1.5 Even though awareness exists about good practices, the same may be compromised at times in the name of speed or economy or due to ignorance and neglect. The materials, equipment, tools, cables, switchgear used in the temporary installation face far more severe environmental working conditions. Use of discarded switchgear, cables, etc, at the construction sites compounds the risk to workmen from shock and fire. The laid down standard need to be followed during construction and demolition meticulously as in the case of permanent installations during building use.

12.2 Installation and Removal of Construction Wiring

All construction wiring work shall be installed by an appropriately registered electrical worker as required by *The Indian Electricity Act, 2003* and only by

<i>Sl No.</i>	<i>Name of Place</i>	<i>Annual Thunder-storm Days</i>	<i>Sl No.</i>	<i>Name of Place</i>	<i>Annual Thunder-storm Days</i>	<i>Sl No.</i>	<i>Name of Place</i>	<i>Annual Thunder-storm Days</i>
1.	Gilgit	7	62.	Sabour	76	123.	Akola	20
2.	Skardu	5	63.	Dumka	63	124.	Amraoti	32
3.	Gulmarg	53	64.	Darjeeling	28	125.	Nagpur	45
4.	Srinagar	54	65.	Jalpaiguri	68	126.	Gondia	10
5.	Dras	3	66.	Malda	59	127.	Aurangabad	34
6.	Kargil	2	67.	Asansol	71	128.	Mumbai	16
7.	Leh	3	68.	Burdwan	39	129.	Alibag	12
8.	Jammu	26	69.	Kharagpur	76	130.	Ahmadnagar	10
9.	Dharmsala	13	70.	Kolkata	70	131.	Parbhani	32
10.	Amritsar	49	71.	Sagar Island	41	132.	Pune	22
11.	Pathankot	4	72.	Dhubri	8	133.	Mahabaleshwar	14
12.	Mandi	46	73.	Tezpur	27	134.	Ratnagiri	6
13.	Ludhiana	12	74.	Dibrugarh	98	135.	Sholapur	23
14.	Simla	40	75.	Sibsagar	103	136.	Miraj	25
15.	Patiala	26	76.	Shillong	75	137.	Vengurla	39
16.	Ambala	9	77.	Cherrapunji	49	138.	Nizambad	36
17.	Hissar	27	78.	Silchar	33	139.	Hnamkonda	43
18.	Delhi	30	79.	Kohima	34	140.	Hyderabad	28
19.	Bikaner	10	80.	Imphal	49	141.	Khammam	26
20.	Phalodi	14	81.	Deesa	7	142.	Kalingapatam	20
21.	Sikar	17	82.	Dwarka	5	143.	Vishakapatnam	46
22.	Barmer	12	83.	Jamnagar	8	144.	Rentichintala	42
23.	Jodhpur	23	84.	Rajkot	12	145.	Masulipatam	20
24.	Ajmer	26	85.	Ahmedabad	11	146.	Ongole	25
25.	Jaipur	39	86.	Dohad	17	147.	Kurnool	29
26.	Kankroli	36	87.	Porbandar	3	148.	Anantpur	22
27.	Mount Abu	5	88.	Veraval	3	149.	Nellore	18
28.	Udaipur	38	89.	Bhavnagar	11	150.	Bidar	15
29.	Neemuch	28	90.	Vadodara	8	151.	Gulbarga	34
30.	Kota	27	91.	Surat	4	152.	Bijapur	9
31.	Jhalawar	40	92.	Gwalior	53	153.	Belgaum	31
32.	Mussorie	61	93.	Guna	33	154.	Raichur	17
33.	Roorkee	74	94.	Nowgong	59	155.	Gadag	21
34.	Najibabad	36	95.	Satna	41	156.	Bellary	22
35.	Mukteswar	53	96.	Sagar	36	157.	Karwar	27
36.	Meerut	—	97.	Bhopal	44	158.	Honavar	5
37.	Bareilly	34	98.	Jabalpur	50	159.	Chikalhana	24
38.	Aligarh	30	99.	Umaria	37	160.	Mangaluru	36
39.	Agra	24	100.	Ambikapur	29	161.	Hassan	26
40.	Mainpuri	23	101.	Indore	34	162.	Bengaluru	46
41.	Bahraich	31	102.	Hoshangabad	37	163.	Mysuru	44
42.	Gonda	22	103.	Panchmarhi	30	164.	Kozhikode	39
43.	Lucknow	18	104.	Seoni	51	165.	Palghat	35
44.	Kanpur	26	105.	Pendadah	56	166.	Kochi	69
45.	Fatehpur	24	106.	Raipur	34	167.	Alleppey	51
46.	Jhansi	20	107.	Chhindwara	27	168.	Thiruvananthapuram	68
47.	Allahabad	51	108.	Kanker	37	169.	Vellore	25
48.	Varanasi	51	109.	Jagdapur	35	170.	Chennai	47
49.	Azamgarh	1	110.	Balasure	81	171.	Udhagamandalam	24
50.	Gorakhpur	11	111.	Chandbali	75	172.	Salem	69
51.	Katmandu	74	112.	Angul	81	173.	Cuddalore	37
52.	Motihari	38	113.	Bhubaneswar	46	174.	Coimbatore	40
53.	Darbhanga	10	114.	Puri	33	175.	Trichchirapalli	41
54.	Patna	33	115.	Gopalpur	34	176.	Nagappattinam	15
55.	Gaya	38	116.	Jharsuguda	85	177.	Kodaikanal	82
56.	Daltonganj	73	117.	Sambalpur	67	178.	Madurai	39
57.	Hazaribagh	73	118.	Titlagarh	24	179.	Pamban	5
58.	Ranchi	34	119.	Rajgangpur	1	180.	Tuticorin	14
59.	Chaibasa	70	120.	Dahanu	1	181.	Cape Comorin	68
60.	Jamshedpur	66	121.	Nasik	17	182.	Port Blair	62
61.	Purnea	52	122.	Malegaon	13	183.	Car Nicobar I	18
						184.	Minicoy I	20

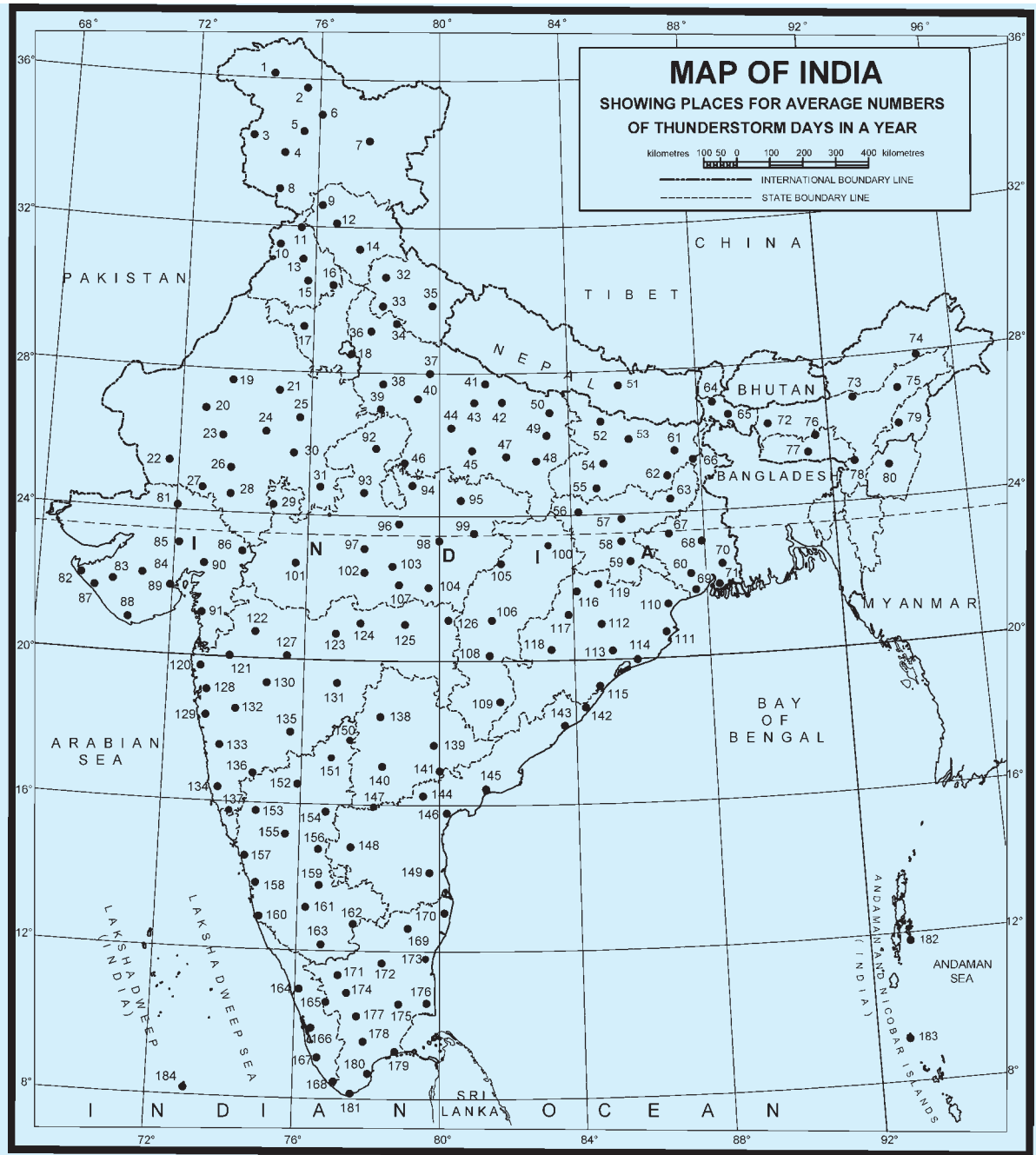

Based upon Survey of India Political map printed in 2002. © Government of India Copyright, 2016

The territorial waters of India extend into the sea to a distance of twelve nautical miles measured from the appropriate baseline.

The interstate boundaries between Arunachal Pradesh, Assam and Meghalaya shown on this map are as interpreted from the North-Eastern Areas (Reorganization) Act, 1971, but have yet to be verified.

The external boundaries and coastlines of India agree with the Record/Master Copy certified by Survey of India.

The responsibility for the correctness of internal details rest with the publisher.

FIG. 30 PLACES FOR AVERAGE NUMBER OF THUNDERSTORM DAYS IN A YEAR

electrical workmen holding licence of the appropriate level of competence depending on the voltage, local generation, etc. The installation should be inspected prior to commissioning and at regular intervals by the Engineer-in-Charge (if he is qualified to inspect electrical installations) or by his representative, who should be competent to inspect an installation.

12.3 Provision of Indicating and Recording Instruments and Meters

Measurement is a prerequisite to analyze the performance. Construction site switchboards should have adequate instrumentation (such as, ammeters, PF meters, voltmeters, energy meters) on different branches of the distribution system so that any abnormal condition or overload is noticed. Considering the nature of varying activity in a construction site, frequent visual and instrument based inspections are necessary keeping record of the same.

12.4 RCCB/RCD

Following shall be ensured in construction and demolition sites:

- a) Every electric supply to which electrical plant can be connected should incorporate an RCCB/RCD so as to protect persons who may come into contact with the electrical plant against electric shock.
- b) The RCCB/RCD(s) should have a rated tripping current not exceeding 30 mA and should have the capacity to carry the load current required by the appliances permitted to be connected in that branch circuit or feeder.
- c) Where construction work supply can only be obtained from a permanent wiring socket outlet, RCCB/RCD should be connected at the socket outlet.
- d) Sub-mains supplying site sheds should incorporate an RCCB/RCD having a rated tripping current not exceeding 100 mA.
- e) Every non-portable RCCB/RCD device on the worksite shall be trip tested by the built-in push button test monthly, and performance tested for operation before being put into service and thereafter at least once every 12 months. It shall also be subjected to an imbalance of current not less than the rated residual current and shall trip in a time not exceeding 6 s.
- f) Every portable RCCB/RCD device on the worksite shall be trip tested by the built-in push button test. The test shall be done prior to use and each day while in use; and it shall be performance tested for operation before

being put into service and thereafter at least once every 3 months. It shall also be subjected to an imbalance of current not less than the rated residual current and shall trip in a time not exceeding 6 s.

- g) Results of RCCB/RCD tests shall be recorded and kept on site or made available for audit and kept for a minimum period of 5 years [excluding the daily push button test for portable RCCB/RCD(s)].
- h) Portable RCCB/RCD(s) when tested shall be fitted with a durable, non-reusable, non-metallic tag. The tag shall include the following information:
 - 1) The name of the person or company who performed the tests; and
 - 2) The test or retest date.

The recommended colour coding for tags on tested RCCB/RCD, which is prescribed below should be indicated by its colour representing the period when the test was performed:

January – March	: Red
April – June	: Green
July – September	: Blue
October – December	: Yellow

- j) Portable generators should be fitted with RCDs and the RCDs should be fitted with core balance earth leakage protection having a rated tripping current not exceeding 30 mA.
- k) Personal hoists used on construction sites shall be supplied from a separate final sub-circuit originating from the main switchboard; and be suitably identified by marking this supply, the RCD/MCB feeding it.

12.5 Temporary Supply Switchboards

All temporary supply switchboards used on building, construction and demolition sites shall be of robust construction and either securely attached to a pole, post wall or other structure which may be of stable freestanding design and,

- a) where installed in outdoor locations, should be constructed and maintained to IP23 (or higher) rating so that safe operation is not affected by the weather;
- b) switchboards should incorporate the support and elevation of cables and flexible extension cords;
- c) switchboard enclosures shall be provided with an insulated or covered tie-bar or similar arrangement for the anchorage of the cables

- or flexible cords in order to prevent strain and mechanical damage at the termination of the cables or cords;
- d) switchboards should be provided with a door and locking facility. The doors should be designed and attached in a manner that will not damage any flexible cord connected to the board and should protect the switches from mechanical damage;
 - e) the door should be provided with signs (in English, Hindi and at least one local language) stating, 'KEEP CLOSED — LEADS THROUGH BOTTOM';
 - f) switchboards should have an insulated slot (with edges suitably shaped or covered with plastic or rubber trims to avoid damaging the cable insulation/sheath) at the bottom for the passage of leads;
 - g) switchboards should be attached to a permanent wall or suitable portable or temporary structure in an elevated position suitable for easy access and least interference with the activity in the area.
 - h) if the floor in that area is likely to be wet, additional precautions are necessary and an insulated platform should preferably be provided for access to operation of switches. Personal protective equipment such as gloves should be available, placed near the switchboard, as an alternative.
 - j) a clearance of at least 1.0 m should be maintained in front of all switchboards;
 - k) the contractor or nominated persons should ensure that all power circuits are isolated or made inaccessible so as to eliminate the risk of fire, electric shock or other injury to persons after completion of the daily work;
 - m) switchboards shall be legibly and indelibly marked with a set of numbers or letters or both which uniquely identify the switchboard from others on a site;
 - n) switchboards shall be marked to indicate the presence of live parts in accordance with symbols such as the following drawing:



- p) chart indicating first aid measures for electric

shock management should be placed near the switchboard;

- q) 'Lock Out and Tag Out' procedures as adopted should be displayed;
- r) the switchboard should be lighted properly to ensure its identification and safe working; and
- s) all switchboards should have their identification names (or/and numbers) so that and communication/instructions about them are unambiguous.

12.6 Cables Used in Worksite Installations

12.6.1 Worksite poses a number of hazards to the cables. The conditions are severe compared to those in permanent installations. Cables face dust, moisture, abrasives and even impact unlike those in permanent installations. Extra care should be taken to frequently inspect the cables and discard cables which show signs of damage as a damaged insulation combined with moisture can be dangerous.

12.6.2 Cables are likely to be run over by vehicles. Suitable protection by a steel pipe or hume pipe or steel plate, whichever is appropriate, is required. Dragging of cables damages their sheath/insulation and may also cut a few strands of the conductor due to stretching, effectively reducing the current carrying capacity.

12.6.3 Overhead installation of cables is a common practice. Such installations should use a GI wire to carry the weight of the cable without causing the stretching of the cable. The carrier GI wire should be earthed. Unarmoured cables shall not be installed on metallic roofs or similar structures unless suitably protected against mechanical damage.

Overhead wiring should be positioned to avoid crossing roadways or accessways where cranes, high loads, or heavy machinery may travel. Where it is not possible to avoid accessways an effective means shall be provided to minimize the risk of the vehicular contact with the aerial wiring system. This condition may be satisfied by the placement of flagged catenary wires or cables of suitable material across the accessway 6 m on either side of the overhead wiring and 0.6 m below the lowest point of the overhead electrical cables or lower.

All aerial conductors installed on construction and demolition sites shall be insulated. Cables supported by means of a catenary shall be stranded or shall be flexible cables affording double insulation or the equivalent of double insulation. Construction wiring (including switchboards) shall be visually inspected at intervals not exceeding 6 weeks.

12.7 Extension Cords and Fittings

12.7.1 It shall be ensured that 3-pin plugs and cord extension sockets used on flexible extension cords and portable power tools are either of non-rewirable (moulded) or transparent type. Cables that are normally used for fixed wiring should not be used as flexible extension cords.

12.7.2 Flexible extension cords shall not be located with plug socket connections in wet places or places where they may be subject to damage by liquids. Fittings for flexible cables or flexible extension cords shall be wired identically and the identity of phase, neutral and earth connections are preserved in a like manner. Bending radius limits for cables should be strictly ensured; else internal breakage of strands can occur leading to reduction of capacity, spot heating, etc.

Flexible extension cords used in multi-storeyed building construction works shall be confined to the same floor as the power source, except in case of formwork; external staging; lift or service shafts; and stairwells. Extension cords shall be confined to not more than one storey above or below the location of the switchboard and be mechanically protected in the transition area between storeys and in places where damage is likely to occur.

The recommended maximum length of a 230 V cord extension is given below:

<i>Sl No.</i>	<i>Cord Extension Set Rating</i>	<i>Conductor Area</i>	<i>Maximum Length of Flexible Cord</i>
(1)	A	mm ²	m
(1)	(2)	(3)	(4)
i)	10	1.0	25
		1.5	35
		2.5	60
ii)	15	1.5	25
		2.5	40
iii)	20	2.5	30
		4.0	50

12.7.3 Joints in temporary wiring shall be avoided. Unavoidable joints should be made with suitable crimped ferrule and insulated with PVC tape on individual core joints and further protected by a sleeve or a covering of tape. Combination of teflon tape followed by PVC tape is recommended where exposure to water is anticipated.

12.7.4 Construction wiring shall be readily distinguishable from permanent wiring by using cable

of a different colour or by attaching iridescent yellow tape spaced at intervals not exceeding 5 m and stamped with the words 'construction wiring'.

12.8 Electrical Plant in Service Testing

Electrical plant shall be inspected and tested in accordance with the following:

- a) Movable electrical plant that is hand held or portable during operation or moved between operations and is subject to damage or harsh environment shall be examined and tested every 3 months.
- b) All other electrical plant used for construction purposes shall be inspected and tested at intervals not exceeding 6 months.
- c) When any equipment inspected or tested in accordance with (a) and (b) is found to be unsatisfactory, it shall be withdrawn from service immediately and have a label attached to it, 'Warning against Further Use'. Electrical plant found to be unsatisfactory shall not be returned to service until it has been repaired and retested.
- d) The inspection and testing specified should be carried out by an authorized/qualified person.
- e) The results of the inspection of electrical plant should be recorded and kept on site or made available for inspection by authorities. Information recorded shall include,
 - 1) the name of the person or company who performed the tests;
 - 2) the test or retest date; and
 - 3) identification of faulty equipment and action taken to repair or remove it from use.

12.9 Lighting

Following in respect of lighting shall be ensured in construction and demolition sites:

- a) *Access lighting* — Adequate artificial lighting should be installed to illuminate the work area, if there is insufficient natural lighting. Lamps in luminaires shall be protected against mechanical damage. Luminaires installed as part of the permanent electrical installation in site accommodation, may not require further mechanical protection.

Sufficient battery powered lighting shall be installed in stairways and passageways to allow safe access and exit from the area if there is insufficient natural lighting. If there is a loss of supply to the normal lighting in the area, it should be ensured that battery powered lighting

has sufficient capacity to operate for one hour to allow persons to exit the building safely.

Temporary wiring supplying lighting circuits should be connected to the designated lighting circuits of the switchboard.

- b) *Task lighting* — Portable luminaires shall be provided with the appropriate ingress protection (IP) rating. Task lighting in many construction site may have to move continuously in steps as the work progresses. The lighting system should also be shifted in suitable steps instead of simply extending the cables without any consideration for safety. Hand held additional lights, if any, should be taken from a socket protected by a RCCB/RCD of 30 mA setting just like hand held tools.
- c) *Lift and service shaft lighting* — Lift and service shaft lighting may have either construction wiring or permanent wiring. Fluorescent lighting should be used. The lights should be located on the floor above or below the work area. It shall be ensured that the emergency lighting has sufficient battery capacity to operate for a minimum of 1 h, if there is a loss of supply to the normal lighting in the area.
- d) *Lighting in means of egress* — Sufficient battery powered lighting shall be installed in stairways and passageways to allow safe access and exit from the area if there is insufficient natural lighting. If there is a loss of supply to the normal lighting in the area it shall be ensured that battery powered lighting has sufficient capacity to operate for sufficient time to allow persons to exit the building safely.
- e) *Illumination of signs and warning boards* — Sufficient lighting should be available to illuminate the sign boards and warning boards. These lights may also be a part of the lighting set for means of egress.

12.10 Transportable Construction Buildings (Site Sheds)

Electrical installations to transportable construction buildings shall comply with the following:

- a) If supply is by means of a flexible cord, the same shall not be taken from one transportable building to another transportable building;
- b) The flexible cord supplying a transportable building should not be more than 15 m in length;
- c) Each amenity in the building shall be connected/supplied by a flexible cord to a final sub-circuit protected by an RCCB/RCD

device with a rated tripping current not exceeding 30 mA; these flexible cords should be protected from mechanical damage and power outlets in site sheds should be used to supply power to the equipment and lighting within the shed only; and

- d) Socket-outlets installed on the outside of transportable building shall be used only to supply power to the following:
 - 1) Electrical equipment and lighting immediately adjacent to those transportable buildings.
 - 2) Other transportable buildings when the socket-outlet is part of an interconnecting system and the flexible cord supplying those transportable buildings has a maximum length of 15 m.

12.11 Lock-Out and Tag-Out Practices

Whenever an electrician is to work on a branch feeder from the switchboard it becomes necessary that the switch feeding the feeder on which work is done is to be switched-off and should be kept switched-off till the same electrician decides to switch on after completion of work either for testing or for putting the section back into service. To ensure that during the period an electrician is working on a feeder or the equipment it feeds, the practice is to put a 'Tag' on the concerned switch. The tag will carry details about which authorized worker has put the tag and when and who is authorized to remove it. This is a very critical operating practice for maintenance of the electrical system and following it is of particular importance in the case of temporary installations, where such requirements arise more often than in permanent installations.

Lock-out procedure shall be similar to the above but the difference is that the relevant switch is kept locked in off position and the key is kept by the person or the team leader who will be working on the feeder. The system should also maintain a register where the activities of this nature and the details of action (repair, transfer of the end equipment to a new location, addition of a new appliance on the feeder, etc) are recorded.

12.12 Standard Operating and Maintenance Practices in Sites with More than One Source of Electricity

12.12.1 In medium and large construction sites it is common to use local generation of electricity by a diesel generating set. The reasons may be lack of dependable local/city distribution system for continuous power supply, high cost of temporary connection charges, restrictions on use of certain equipment like welding transformers on temporary connection, etc. Apart from DG sets for power requirement of site construction

equipment, there may be office equipment with computers, site laboratory equipment which require uninterrupted power supply. Shock hazards depend on the voltage of the system and the consequent current flow through the body. As such shock risk associated with all these sources is the same.

12.12.2 Wherever an alternative power supply is provided, proper protocols shall be adopted for the supply from different systems and the associated change-over switch or contactors. Risk increases due to existence of more than one source of power supply. System schematics, operating practice and essential interlock between the different sources of power should be displayed and followed systematically. Earthing for each system should be provided. Changeover switches should be of 4-pole in order to ensure that earth leakage protections operate properly with each one of the power sources. The system should also maintain a register where the activities related to each source of power is recorded and the actions to be taken are provided.

12.13 Earthing or Grounding

12.13.1 Earthing or grounding is an essential prerequisite for any electrical system from the aspect of safety of personnel, equipment, appliances and for avoidance of fire due to short-circuit or of feeding energy to a short circuit originating from any other cause consequent to damage to insulation by the fire.

12.13.2 The standard earthing practice is applicable to temporary installations also. The earthing sets installed at the initial development of the site can be planned to be retained as earthing sets for use even after the completion of the building for the permanent installation.

12.13.3 The minimum requirement of earthing for any temporary electrical installation is given hereunder for easy adherence to the basic minimum. It is recommended to follow the earthing requirements given in 8.

12.13.3.1 The neutral of the system of each source or generator shall be having two distinct connection to two distinct earthing sets. All metal parts associated with electrical equipment are required to be connected to earth. The minimum requirement is the provision of two pipe earthing sets each with a pipe of 2.5 m length and separated by at least 2.5 m between them and connected to the source neutral by a conductor of cross-section more than half the size used for the phase conductor.

12.13.3.2 Earth continuity shall be maintained all over the site wherever electricity is made available and the earth continuity conductor shall have a cross-section at least more than that used for the phase conductor.

12.13.3.3 Wherever the requirements of earthing and use of RCD or RCCB cannot be satisfactorily met with at any site and electrical hand tools are required to be

used, low voltage (< 50 V) appliances or self-contained battery operated tools shall be used as a safe alternative. This applies to work under damp or water logged areas also.

13 PROTECTION OF HUMAN BEINGS FROM ELECTRICAL HAZARDS

13.1 General

Danger to persons due to contact with live parts is caused by the flow of the current through the human body. The effects on the human body are dependent on the amount of the current flow and the duration of the flow. The current flow through the human body depends on the voltage and the resistance in the path. The contact resistance forms an important or significant contributor to the total resistance for the current flow. The contact resistance reduces by a factor of 100 to 1 000 due to the body part being wet and also the touch pressure at the point of contact.

13.1.1 Physiological Effects of Electric Shock

The following are the physiological effects of electric shock:

- a) *Tetanization* — The muscles affected by the current flow involuntarily contract and letting go of gripped conductive parts is difficult.

NOTE — Very high currents do not usually induce muscular tetanization because, when the body touches such currents, the muscular contraction is so sustained that the involuntary muscle movements generally throw the subject away from the conductive part.

- b) *Breathing arrest* — If the current flows through the muscles controlling the lungs, the involuntary contraction of these muscles alters the normal respiratory process and the subject may die due to suffocation or suffer the consequences of traumas caused by asphyxia.
- c) *Ventricular fibrillation* — The most dangerous effect is due to the superposition of the external currents with the physiological ones, which, by generating uncontrolled contractions, induce alterations of the cardiac cycle. This anomaly may become an irreversible phenomenon since it persists even when the stimulus has ceased.
- d) *Burns* — They are due to the heating deriving, by Joule effect, from the current passing through the human body.

13.1.2 On a time-current diagram, four zones to which the physiological effects of alternating current (15 to 100 Hz) passing through the human body have been related are given in Fig. 31.

13.1.3 In general, 'special locations' involve one or more of the following environmental conditions or

different risks, which in the absence of special arrangements, will give rise to an increased risk of electric shock:

- 1) Wetness or condensation, that is, reduced skin resistance;
- 2) Absence of clothing, that is, greater opportunity to make direct or indirect contact through increased area of bare skin and bare feet;

- 3) Proximity of earthed metalwork, that is, increased risk of indirect contact; and
- 4) Arduous or onerous site conditions, that is, conditions of use that may impair the effectiveness of the protective measures.

13.1.3.1 The additional requirements for these 'special locations' have been devised by assessing the relevant risks under each of the above categories and making adjustments to the protective measures accordingly. The

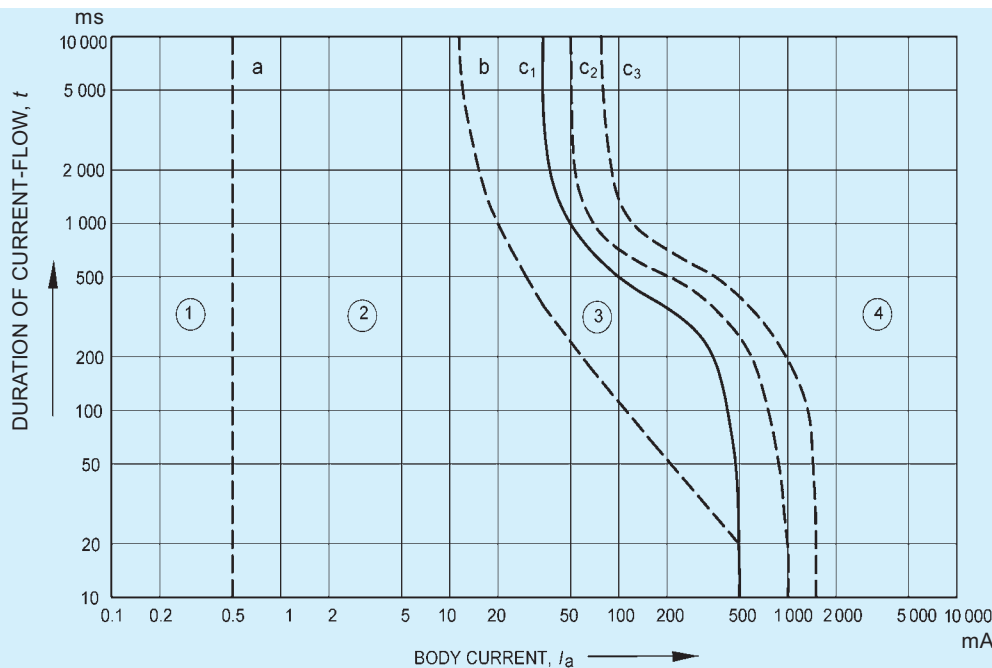

NOTES

- 1 As regards ventricular fibrillation, this figure relates to the effects of current which flows in the path 'left hand to feet'. For other current paths, see 5 and Table III of the accepted standard [8-2 (50)].
- 2 The point 500 mA/100 ms corresponds to fibrillation probability in the order of 0.14 percent.

Zones	Physiological effects
Zone 1	Usually no reaction effects.
Zone 2	Usually no harmful physiological effects.
Zone 3	Usually no organic damage to be expected. Likelihood of muscular contractions and difficulty in breathing, reversible disturbances of formation and conduction of impulses in the heart, including atrial fibrillation and transient cardiac arrest without ventricular fibrillation increasing with current magnitude and time.
Zone 4	In addition to the effects of Zone 3, probability of ventricular fibrillation increasing up to about 5 percent (curve c_2), up to about 50 percent (curve c_3) and above 50 percent beyond curve c_3 . Increasing with magnitude and time, pathophysiological effects such as cardiac arrest, breathing arrest and heavy burns may occur.

FIG. 31 TIME/CURRENT ZONES OF THE EFFECTS OF a.c. CURRENTS (15 Hz TO 100 Hz)

intention is to remove or minimize the additional risks to users presented by the electrical installations within these 'special locations'. Designers, installers and operators of such installations should consider the particular requirements of the installation and design and install or operate the installation to reduce or protect against risks from these requirements. It should be however recognized, that all installations require adequate regular periodic inspection and testing, and any necessary maintenance or repair works be properly carried out.

13.2 Protection Against Electric Shocks

13.2.1 Protective measures against electric shock are based on following two common dangers:

- a) Contact with an active conductor, which is live with respect to earth in normal circumstances; and is referred to as a 'direct contact' hazard.
- b) Contact with a conductive part of an apparatus which is normally dead, but which has become live due to insulation failure in the apparatus; and is referred to as an 'indirect contact' hazard. The third type of shock hazard exists in the proximity of MV or LV (or mixed) earth electrodes which are passing earth-fault currents.
- c) This hazard is due to potential gradients on the surface of the ground and is referred to as a 'step-voltage' hazard; shock current enters one foot and leaves by the other foot, and is particularly dangerous for four-legged animals. A variation of this danger, known as a 'touch voltage' hazard can occur, for instance, when an earthed metallic part is situated in an area in which potential gradients exist. Touching the part would cause current to pass through the hand and both feet. Animals with a relatively long front-to-hind legs span are particularly sensitive to step-voltage hazards.

NOTE — Cattle have been killed by the potential gradients caused by a low voltage (240/415 V) neutral earth electrode of insufficiently low resistance.

13.2.2 Potential-gradient problems as mentioned in **13.2.1** are not normally encountered in electrical installations of buildings, provided that equipotential conductors properly bond all exposed metal parts of equipment and all extraneous metal (that is, those which are not part of an electrical apparatus or the installation, for example structural steelwork, etc) to the protective-earthing conductor.

Potential-gradient problems do exist at the switchboards of electrical installations. Even where components, such as the metallic cubicle and operating handle are earthed, there is a possibility that for very short duration when a fault current is flowing through the metal part, the potential of the earthed metal part may be increased due to the current flow. The practice of using an insulating

mat at places where the switches are to be operated, is for protection against such transient over-voltages in earthed metal parts (if the metal part is not earthed the transient overvoltage will be beyond safe limits).

With the increased use of pumped water in bathrooms for spa-baths, power showers, etc, there is a need, on occasions, to provide for motive power within the area of the bath. In order to protect against direct and indirect contact, supplies for such equipment shall be by extra-low-voltage-system with the nominal voltage not exceeding 12 V r.m.s.

It is a requirement to provide supplementary equipotential bonding by bonding all simultaneously accessible exposed and extraneous conductive parts. This should include all in-coming metallic services (including metal wastes) and any structural metalwork, including a metallic floor grid, if provided.

Protection measures as given in **13.2.3** to **13.2.5** shall also be provided for protection against electric shock.

13.2.3 *Direct-Contact Protection or Basic Protection*

The main form of protection against direct contact hazards is to contain all live parts in housings of insulating material or in metallic earthed housings, by placing out of reach (behind insulated barriers or at the top of poles) or by means of obstacles. Where insulated live parts are housed in a metal envelope, for example transformers, electric motors and many domestic appliances, the metal envelope is connected to the installation protective earthing system. Protection classification and the details of the different levels of protection are designated by IP XX and IK X {see good practice [8-2(6)] and IEC 62262:2002 'Degrees of protection provided by enclosures for electrical equipment against external mechanical impacts (IK code)'}. The metallic enclosure has to demonstrate an electrical continuity, then establishing a good segregation between inside and outside of the enclosure. Proper grounding of the enclosure further participates to the electrical protection of the operators under normal operating conditions. For LV appliances this is achieved through the third pin of a 3-pin plug and socket. Total or even partial failure of insulation to the metal, can raise the voltage of the envelope to a dangerous level (depending on the ratio of the resistance of the leakage path through the insulation, to the resistance from the metal envelope to earth). The minimum standard for any equipment has to be IP2X to limit the possibility of a finger touching a live part of an electrical system.

13.2.4 *Indirect-Contact Protection or Fault Protection*

A person touching the metal envelope of an apparatus with a faulty insulation is said to be making an indirect contact. An indirect contact is characterized by the fact that a current path to earth exists (through the protective earthing (PE) conductor) in parallel with the shock current through the person concerned. The hazard in such cases is dependent on the earth resistance and the

resistance of the earth continuity conductor, which would effectively be in parallel to the path of flow of current through the human body.

Extensive tests have shown that, providing the potential of the metal envelope not greater than 50 V with respect to earth, or to any conductive material within reaching distance, no danger exists.

If the insulation failure in an apparatus is between a MV conductor and the metal envelope, it is not generally possible to limit the rise of voltage of the envelope to 50 V or less, simply by reducing the earthing resistance to a low value. The solution in this case is to create an equipotential 'Earthing systems'. Insulation faults affecting the MV substation's equipment (internal) or resulting from atmospheric overvoltages (external) may generate earth currents capable of causing physical injury or damage to equipment. Preventive measures essentially consist of,

- a) connecting all substation frames to the earth bar;
- b) minimizing earth resistance; and
- c) fast tripping and isolation of the fault by the operation of the fuse or circuit breaker.

13.2.5 In order to provide protection against electric shock due to leakage current for human being, a 30 mA RCCB/ RCD shall be installed at distribution board incomer of buildings, such as residential, schools and hospitals. For all other buildings, a 100 mA RCCB will suffice for protection against leakage current.

13.2.6 Additional Protection Against Electric Shocks

In a.c. systems, additional protection by means of a residual current protective device (RCD) with sensitivity not exceeding 30 mA shall be provided for,

- a) socket-outlets with a rated current not exceeding 20 A that are for use by ordinary person and are intended for general use; and
- b) mobile equipment with a current rating not exceeding 32 A for use outdoors.

The residual current devices shall be independent of the line voltage, except for installation operated, tested and inspected by skilled persons.

13.3 Hazards Due to Multiple Electrical Sources

The need for reliability of power supply and continued supply for different equipment leads to provision of redundant equipment chains as well as the provision of more than one source of power.

For critical installations it is normal to have more than one service connection, preferably from two different paths, so that at least one of the paths is in service at any time.

At the next level to cover the failure of the area distribution network local standby generating systems such as diesel generating sets are provided. For extremely critical loads which cannot tolerate even short break in

service UPS systems which store energy in a battery bank and release it during the power failure become necessary.

As such multiple sources have become a necessary common feature in most large buildings. Even in small buildings activities depending on computers, etc, leads us to provide a standby system with an UPS or an inverter.

Where there is more than one source the shock hazards increase due to various reasons and a proper drill and display of instructions becomes necessary so that the users and in particular the operating and maintenance personnel are warned of the different sources and the associated protocol.

13.4 Care and Design of Electrical Installations for Human Safety

Location of switches and location of electrical equipment has to be done with a view to avoid electrical hazards to the users from the angle of human safety.

Most common hazard is of direct contact and that too when associated with wet surfaces. Wet surface reduces the contact resistance and thereby increases the current flow.

The second most common hazard comes up from old or/and damaged or under-sized flexible cords used for connection of portable equipment or devices.

The recommendations for typical areas requiring special attention are given in **13.4.1** to **13.4.5**.

13.4.1 Bath Room Installations

13.4.1.1 Geyser

The geyser or a storage water heater is not a portable device as it requires connection to the electricity line as well as to the water supply lines. The electrical connection will be from a 16 A socket outlet located at least 500 mm away from the plumbing connections. The switch for the geyser should not be accessible from the bath area or the shower area, to avoid a person standing on the wet surface touching the switch. The switch should be located away from the wet floor area of a bath room and preferably outside near the entrance to the bath room. This switch should have a built in indicator to display the status.

13.4.1.2 Shaver socket

Shaver sockets are located near the mirror. The socket will be fed from an isolating transformer (which in addition to providing electrical isolation between the output to the shaver and the building electrical system, may also give a voltage choice selection) to avoid shock hazard.

Shaver sockets which do not have a built in isolating transformer should be protected at the back by an RCCB/ RCD of 10 mA sensitivity.

13.4.1.3 Protection against electric shocks in bathrooms

All circuits in bathrooms shall be protected by an RCCB/

RCD with a sensitivity of 30 mA. The an RCCB/RCD shall be in compliance with its relevant Indian Standards.

13.4.1.4 Protection against electric shocks in sauna heater

All circuits in sauna shall be protected by an RCCB/RCD with a sensitivity of 30 mA. The RCCB/RCD shall be in compliance with its relevant Indian standards.

13.4.2 Bed Room Installations

For the convenience of operating the lights, fan, etc, from the bed, it is quite a common practice to provide a pendant switch wired with a flexible cord. The flexible cord used should be with an outer sheath and the sheath should be securely clamped at the pendent switch. Use of twisted flexible cables without double insulation is hazardous and should be avoided.

A bed-head control set for all outlets to be controlled, mounted either on the wall accessible from the bed or mounted on the head board of the bed would be a preferable and safer alternative. This alternative requires the termination of the permanently installed wiring at a box near the bed and a flexible multicore sheathed cable for connection from the wall termination box to the control switch set mounted on the bed-head.

13.4.3 Kitchen Installations

Today a large number of gadgets are in use in the kitchen and it would be desirable to provide a large number of combination of 6 A/16 A sockets. As a general guideline any part of the kitchen counter should be within 1 m from a socket outlet as most kitchen appliances come with a 1.5 m or 2 m flexible cord.

The sockets should be located on the basis of the equipment layout and the general purpose outlets would be placed at 150 mm above the kitchen counter level.

For safety, all the socket outlets should be from circuits with an RCCB/RCD protection of sensitivity 30 mA. If an instant geyser is provided the same has to be wired from circuit with a 100 mA RCCB/RCD as 30 mA may cause nuisance tripping for a geyser.

13.4.4 Protection Against Electric Shocks in Swimming Pools and the Other Basins.

For swimming pools and other basins such as basins of swimming pools, paddling pools and their surrounding zones; areas in natural waters such as lakes in gravel pits, coastal and similar areas, specially intended to be occupied by persons for swimming, paddling and similar purposes and their surrounding zones, basins of fountains and their surrounding zones; all electrical systems provided shall be protected by residual current devices with a sensitivity not exceeding 30 mA. The RCD shall be in compliance with its product standard. All circuits for lighting, etc, in contact with water shall be at 24 V or less.

13.4.5 For protection against electric shock in other applications, reference shall be made to National Electric Code.

13.5 Earthing Requirements

Earthing is an essential need for protection against shock. Almost all devices require a proper earth connection through the earthing pin (and socket) and in turn through the earth continuity conductor.

13.6 Heating Appliances and Hot Appliances

Electrical appliance incorporating a heating element pose additional hazards from the possibility of overheating and inadvertent ignition of combustible material in the vicinity. While the installation by itself cannot be made failsafe, it is necessary to provide conspicuous indicators with the switches for the sockets used for such appliances, so that visible indication warns the user that the appliance is 'ON' (many appliances which have their own built in indication, may be in 'OFF' position in their standby mode or in the cut-off mode. Under such conditions the indication associated with the switch would be a gentle reminder.)

Almost all electrical appliances produce heat and require ventilation. The surface of the equipment is likely to be hot. Wherever the surface temperature is likely to be more than 45°C, there should be a protection against the possibility of touching the surface and getting scalded or burnt.

13.7 Switches Getting Supply from Multiple Sources

Use of critical electrical equipment requiring continued power supply even in the absence of the commercial supply are on the increase both at home and in any general office, apart from special functional buildings where multiple or redundant sources is a necessity. Use of UPS systems has become common.

Where there are such points or switches fed from multiple sources, it is desirable to mark these switches or adopt a colour code so that they are identified readily.

Many UPS and Inverters have the feature of tripping on overload followed by automatic restoration after a brief time delay. Such characteristics should be made known to the users, so that accidents do not happen by the uninformed user taking some action assuming that the power supply is not there. Shock hazards are dependent on the system voltage and the hazard level is the same whether it is from the power system or from a mini UPS of a few watts.

13.8 Protection Against Environmental Over-Voltages

Any building today has a number of metallic connections coming into the building or installed over (or near) the building such as lines for electricity, telephone, dish antenna, radio antenna, pipe lines for water supply, sewage, cable of cable TV, solar hot water system, solar photovoltaic array, cell phone tower, wind generator, etc. External disturbances such as lightning, faults in external

systems, can induce over-voltage in the installations within the building.

Buildings are to be provided protection from lightning strikes by a system of 'Faraday Cage' on the basis of hazard assessment. But at the same time use of dish antenna for TV, cable TV (the cable for which is run from building to building on the top, apparently forming a line to catch a lightning stroke) are on the rise and are without any regulation. These installations pose hazards to the installations inside the building.

For sensitive and critical equipment it is necessary to make a separate detailed study and build in appropriate protective device such as shield, suppressor or diverter as may be appropriate for the equipment as well as the type of hazard assessed.

13.9 Flammable Atmosphere and Risk of Ignition by Electricity Leading to Fire or Explosion

13.9.1 Flammable atmospheres are part of the electrical fire and explosion hazards. They are dealt with separately because of the complexities and problems peculiar to the subject. They occur when flammable gas, vapour, mist, aerosol or dust is present in a concentration in air between the upper (UEL) and lower (LEL) explosive limits. Such mixtures ignite if there is a source of ignition also present, such as incentive arcs or sparks from electrical equipment. The risk areas are divided into following zones for flammable gases/vapours:

- a) *Zone 0* — Where the flammable atmosphere is always present.
- b) *Zone 1* — Where the flammable material is present during normal operations and a flammable atmosphere is likely to occur.
- c) *Zone 2* — Where the flammable atmosphere is unlikely during normal operation and if it occurs it will exist only for a short time.

13.9.2 A spark such as from a switch in an explosive atmosphere can trigger a fire or an explosion. In such areas special 'flame-proof' category switches, light fittings, cables, etc, will have to be used. The installation practices are also precise. Zonal boundaries have to be determined by the occupier's specialist staff and marked on the site drawing in plan and elevation. It is a difficult task and requires knowledge of the characteristics of the material and how it disperses from the source of emission.

To illustrate by an example, if LPG leaks from a domestic gas cylinder it creates a hazardous situation. LPG is heavier than air and will settle down at the bottom on the floor with gradually changing ratio of air/LPG mixture as you go up above the floor level and it would be an explosive mixture at a height of a few centimeters above the floor level, which can easily be ignited by a

spark or a flame. LPG stored in a basement (particularly if it is without exhaust picked up from floor level) can be serious situation.

Armed with the zonal boundary plans, the next step is to determine the position of the electrical equipment. Wherever possible, the risk should be avoided or minimized by locating the electrical equipment outside the risk areas or in Zone 2 areas rather than in Zones 0 and 1.

Zone 0 is usually inside reaction vessels or storage tanks. There is not much electrical equipment available for use in Zone 0 and as the risk is high it should be avoided by locating the equipment outside, example, a container can have glazed port-holes so that the interior can be viewed through one and lit from a luminaire shining through another. Zone 1 areas often occur only in the immediate vicinity of where the flammable material is processed. They are invariably surrounded by Zone 2 areas where the electrical apparatus should preferably be situated. It is sometimes possible to light outside site zones by luminaires located at high level in safe areas above the vertical zone boundaries. For flammable interiors, lighting can often be provided by positioning the luminaires outside in a safe location and shining the light through glazed panels in the roof or walls. Again, motors can be outside and drive an internal machine through a long shaft extension passing through a gas-tight seal in the wall. In some plants, it is convenient to locate the motor starters together on a starter panel in a motor control room. This room may either be in a safe area or if within the flammable zone, fed with clean air, from outside the zone, maintained at a positive pressure to ensure that gas cannot enter. Conduits for wiring should be solid drawn or seam welded with screwed joints. Where flammable gases have to be excluded from equipment, barrier seals may be necessary. Flexible metallic conduit should be lined to prevent abrasion of the cable insulation. Aluminium and aluminium alloy conduits and accessories should not be used where frictional contact with oxygen-rich items such as rusty steel might occur and cause sparking.























13.10 Protection Against Fire Due to Leakage Current in the Building

Large number of fire in the building occur due to faulty electrical installation. Mostly, the cause is assigned to over load or short-circuit fault. But there can be one more reason for causing the fire in the building. As the quality of insulation of the cables deteriorate due to ageing over a period of time, certain amount of leakage current flows in the system. This leakage current or tracking is difficult to detect and if it is allowed for a long period of time, say months or years, sparks occur which on a favourable condition, may lead to devastating fire in the building. Ignition of fire due to leakage current or tracking may be prevented by providing residual current devices of 300/500 mA as part of the main distribution board.























ANNEX A
(Clause 2.2)

























DRAWING SYMBOLS FOR ELECTRICAL INSTALLATIONS IN BUILDINGS

Sl No.	Details	Symbol	Sl No.	Details	Symbol
1.	Direct current	—	12.	Overhead Line	
2.	Alternating current, general symbol		13.	Winding, delta	
3.	Alternating current, single-phase, 50Hz		14.	Winding, star	
4.	Alternating current, three-phase, 415 V	3	15.	Terminals	
5.	Alternating current, three-phase with neutral, 50 Hz	3N	16.	Resistance/Resistor	
6.	Neutral	N	17.	Variable resistor	
7.	Positive polarity	+	18.	Impedance	
8.	Negative polarity	-	19.	Inductance/Inductor	
9.	Direct current, 2 conductors 110 V	2 — 110 V	20.	Winding	
10.	Direct current, 3 conductors including neutral 220 V	2N — 220 V	21.	Capacitance, capacitor	
11.	Underground cable		22.	Earth	

Sl No.	Details	Symbol	Sl No.	Details	Symbol
23.	Fault		34.	Auto-transformer	
24.	Flexible conductor		35.	3-Phase transformer with three separate windings-Star-star-delta	
25.	Generator		36.	Starter	
26.	a.c. generator		37.	Direct-on-line-starter for reversing motor	
27.	d.c. generator		38.	Star-delta starter	
28.	Motor		39.	Auto-transformer starter	
29.	Synchronous motor		40.	Rheostatic starter	
30.	Mechanically coupled machines		41.	Switch	
31.	Induction motor, Three-phase, squirrel cage		42.	Contactors	
32.	Induction motor with wound rotor		43.	One - way switch, single pole	
33.	Transformers with two separate windings		44.	One - way switch, two pole	

Sl No.	Details	Symbol	Sl No.	Details	Symbol
45.	One - way switch, three pole		56.	Relay	
46.	Single pole pull switch		57.	Circuit-Breaker	
47.	Multiposition switch for different degrees of lighting		58.	Isolator	
48.	Two-way switch		59.	Residual current circuit breaker	
49.	Intermediate switch		60.	Surge protective device	
50.	Period limiting switch		61.	Fuse	
51.	Time switch		62.	Signal lamp	
52.	Pendant switch		63.	Link	
53.	Push button		64.	Distribution boards, cubicle box, main fuse board with switches	
54.	Luminous push button		65.	Socket outlet, 6A	
55.	Restricted access push button		66.	Socket outlet, 16 A	

SI No.	Details	Symbol	SI No.	Details	Symbol
67.	Combined Switch and Socket Outlet, 6A		78.	Indicating instrument (General symbol)	
68.	Combined switch and socket outlet, 16 A		79.	Recording instrument (General symbol)	
69.	Interlocking switch and socket outlet, 6A		80.	Integrating meter	
70.	Interlocking switch and socket outlet, 16A		81.	Watt-hour meter	
71.	Plug		82.	Clock	
72.	Voltmeter		83.	Master clock	
73.	Ammeter		84.	Current transformer	
74.	Wattmeter		85.	Voltage transformer	
75.	Varmeter		86.	Wiring on the surface	
76.	Power factor meter		87.	Wiring under the surface	
77.	Ohmmeter		88.	Conduit on surface	

Sl No.	Details	Symbol	Sl No.	Details	Symbol
89.	Concealed conduit		101.	Storage type water heater	
90.	Wiring in conduit		102.	Bell	
91.	Lamp		103.	Buzzer	
92.	Lamp mounted on a ceiling		104.	Siren	
93.	Lamp, mounted on a wall		105.	Ceiling fan	
94.	Emergency lamp		106.	Exhaust fan	
95.	Panic lamp		107.	Fan regulator	
96.	Water-tight lighting fitting		108.	Aerial	
97.	Battern lamp holder		109.	Radio receiving set	
98.	Spot light		110.	Television receiving set	
99.	Flood light		111.	Manually operated fire alarm	
100.	Heater		112.	Automatic fire detector switch	

ANNEX B

[Clauses 3.1, 4.2.1 (12) (ix), 4.7.1.2, 4.7.1.4, 4.7.1.5, 4.7.3.1, 5.3.6.8, 5.4.1.1, 5.4.1.3, 6.4.6, 8.2.1 and 9.1.1]

EXTRACTS FROM CENTRAL ELECTRICITY AUTHORITY (MEASURES RELATING TO SAFETY AND ELECTRIC SUPPLY) REGULATION, 2010 FURTHER AMENDED IN 2015

B-1 The following are the extracts of some of the rules:

Regulation 4, Inspection of designated officers and other safety measures

- (1) The register maintained under sub-regulation (2) of regulation 3 shall be produced before the Electrical Inspector when required by him.
- (2) If on inspection, the Electrical Inspector finds that the designated person does not fulfill the required qualification, he shall recommend the removal of the name of such persons from the register.

Regulation 5, Electrical safety officer

- (1) All suppliers of electricity including generating companies, transmission companies and distribution companies shall designate an Electrical Safety Officer for ensuring observance of safety measures specified under these regulations in their organization, for construction, operation and maintenance of power stations, sub-stations, transmission and distribution lines.
- (2) The Electrical Safety Officer shall be an Electrical Engineering degree holder with at least five years of experience in operation and maintenance of electrical installations.
- (3) The Electrical Safety Officer designated under sub-regulation (1), shall carry out periodic tests as per the relevant standards and inspection of such installations for ensuring observance of safety measures specified under these regulations at intervals not exceeding one year, and keep a record thereof in Form I or Form II or Form III, as the case may be, of Schedule IV and test reports, and also keep a register of recommended safety requirements duly acknowledged by the owner with date and compliances thereafter; and such records shall be made available to the Electrical Inspector, as and when required.
- (4) For every electrical installation including factory registered under the *Factories Act*, 1948 (63 of 1948) and mines and oil field as defined in the *Mines Act*, 1952 (35 of 1952), where more than 250 kW of electrical load is connected, the owner of the installation or the

management of the factory or mines, as the case may be, shall designate Electrical Safety Officer having qualification and experience specified in sub-regulation (2), for ensuring the observance of the safety provisions laid under the Act and the regulations made thereunder, who shall carry out recommended periodic tests as per the relevant standards, and inspect such installation at intervals not exceeding one year, and keep a record thereof in Form I or Form II or Form III, as the case may be, of Schedule IV to these regulations; test reports and a register of recommendations in regard with safety duly acknowledged by owner; compliances made thereafter; and such records shall be made available to the Electrical Inspector, as and when required.

Regulation 5A, Chartered Electrical Safety Engineer

The Appropriate Government may authorize Electrical Safety Engineers having the qualification and experience as specified in sub-regulation (2) of regulation 5 to assist the owner or supplier or consumer of electrical installations for the purpose of self-certification under regulation 30 and regulation 43.

Regulation 8, Keeping of records and inspection thereof

- (1) The generating company or licensee shall maintain records of the maps, plans and sections relating to supply or transmission of electricity and submit the same to the Electrical Inspector for inspection as and when required by him.
- (2) The Electrical Inspector shall supply a copy of the report of inspection referred to in sub-regulation (1), to the generating company or licensee, as the case may be.

Regulation 12, General safety requirements pertaining to construction, installation, protection, operation and maintenance of electric supply lines and apparatus

- (1) All electric supply lines and apparatus shall be of sufficient rating for power, insulation and estimated fault current and of sufficient

mechanical strength, for the duty cycle which they may be required to perform under the environmental conditions of installation, and shall be constructed, installed, protected, worked and maintained in such a manner as to ensure safety of human beings, animals and property.

- (2) Save as otherwise provided in these regulations, the relevant code of practice of the Bureau of Indian Standards or National Electrical Code, if any, may be followed to carry out the purposes of this regulation and in the event of any inconsistency, the provisions of these regulations shall prevail.
- (3) The material and apparatus used shall conform to the relevant specifications of the Bureau of Indian Standards or International Electro-Technical Commission where such specifications have already been laid down.
- (4) All electrical equipment shall be installed above the Mean Sea Level (MSL) as declared by local Municipal Authorities and where such equipment is to be installed in the basement, consumer shall ensure that the design of the basement should be such that there is no seepage or leakage or logging of water in the basement.

Regulation 13, Service lines and apparatus on consumer's premises

- (1) The supplier shall ensure that all electric supply lines, wires, fittings and apparatus belonging to him or under his control, which are on a consumer's premises, are in a safe-condition and in all respects fit for supplying electricity and the supplier shall take precautions to avoid danger arising on such premises from such supply lines, wires, fittings and apparatus.
- (2) Service lines placed by the supplier on the premises of a consumer which are underground or which are accessible shall be so insulated and protected by the supplier as to be secured under all ordinary conditions against electrical, mechanical, chemical or other injury to the insulation.
- (3) The consumer shall, as far as circumstances permit, take precautions for the safe custody of the equipment on his premises belonging to the supplier.
- (4) The consumer shall also ensure that the installation under his control is maintained in a safe condition.

Regulation 14, Switchgear on consumer's premises

- (1) The supplier shall provide a suitable switchgear in each conductor of every service line other than an earthed or earthed neutral conductor or the earthed external conductor of a concentric cable within a consumer's premises, in an accessible position and such switchgear shall be contained within an adequately enclosed fireproof receptacle:
Provided that where more than one consumer is supplied through a common service line, each such consumer shall be provided with an independent switchgear at the point of rigid junction to the common service.
- (2) Every electric supply line other than the earthed or earthed neutral conductor of any system or the earthed external conductor of a concentric cable shall be protected by a suitable switchgear by its owner.

Regulation 15, Identification of earthed and earthed neutral conductors and position of switches and switchgear therein

Where the conductors include an earthed conductor of a two-wire system or an earthed neutral conductor of a multi-wire system or a conductor which is to be connected thereto, the following conditions shall be complied with:

- (i) an indication of a permanent nature shall be provided by the owner of the earthed or earthed neutral conductor which is to be connected thereto, to enable such conductor to be distinguished from any live conductor and such indication shall be provided—
 - (a) where the earthed or earthed neutral conductor is the property of the supplier, at or near the point of commencement of supply;
 - (b) where a conductor forming part of a consumer's system is to be connected to the supplier's earthed or earthed neutral conductor, at the point where such connection is to be made;
 - (c) in all other cases, at a point corresponding to the point of commencement of supply or at such other points as may be approved by an Electrical Inspector.
- (ii) no cut-out, link or switch other than a linked switch arranged to operate simultaneously on the earthed or earthed neutral conductor and live conductor shall be inserted or remain inserted in any earthed or earthed neutral conductor of a two wire-system or in any earthed or earthed neutral conductor of a

multi-wire system or in any conductor connected thereto.

Provided that the above requirement shall not apply in case of —

- (a) a link for testing purposes, or
- (b) a switch for use in controlling a generator or transformer.

Regulation 16, Earthed terminal on consumer's premises

- (1) The supplier shall provide and maintain on the consumer's premises for the consumer's use, a suitable earthed terminal in an accessible position at or near the point of commencement of supply.

Provided that in the case of installation of voltage exceeding 250 V the consumer shall, in addition to the aforementioned earthing arrangement, provide his own earthing system with an independent electrode.

Provided further that the supplier may not provide any earthed terminal in the case of installations already connected to his system on or before the date to be specified by the State Government in this behalf if he is satisfied that the consumer's earthing arrangement is efficient.

- (2) The consumer shall take all reasonable precautions to prevent mechanical damage to the earthed terminal and its lead belonging to the supplier.
- (3) The supplier may recover from the consumer the cost of installation on the basis of schedule of charges published by him in advance and where such schedule of charges is not published, the procedure laid down, in regulations 63 shall apply.

Explanation — For the purposes of sub-regulation (1), the expression "Point of commencement of supply of electricity" shall mean the point at the incoming terminal of the switchgear installed by the consumer.

Regulation 17, Accessibility of bare conductors

Where bare conductors are used in a building, the owner of such conductors shall —

- (a) ensure that they are inaccessible;
- (b) provide in readily accessible position switches for rendering them dead whenever necessary; and
- (c) take such other safety measures as are specified in the relevant Indian Standards.

Regulation 18, Danger notices

The owner of every installation of voltage exceeding 250 V shall affix permanently in a conspicuous position a danger notice in Hindi or English and the local language of the District, with a sign of skull and bones of a design as per IS-2551 on

- (a) every motor, generator, transformer and other electrical plant and equipment together with apparatus used for controlling or regulating the same;
- (b) all supports of overhead lines of voltage exceeding 650 V which can be easily climbed upon without the aid of ladder or special appliances;
- (c) luminous tube sign requiring supply, X-ray and similar high frequency installations of voltage exceeding 650V but not exceeding 33 kV:

Provided that where it is not possible to affix such notices on any generator, motor, transformer or other apparatus, they shall be affixed as near as possible thereto, or the word 'danger' and the voltage of the apparatus concerned shall be permanently painted on it:

Provided further that where the generator, motor, transformer or other apparatus is within an enclosure one notice affixed to the said enclosure shall be sufficient for the purposes of this regulation.

Explanation — For the purpose of clause (b), rails, tubular poles, wooden supports, reinforced cement concrete poles without steps, I-sections and channels, shall be deemed as supports which cannot be easily climbed upon.

Regulation 19, Handling of electric supply lines and apparatus

- (1) Before any conductor or apparatus is handled, adequate precautions shall be taken, by earthing or other suitable means, to discharge electrically such conductor or apparatus, and any adjacent conductor or apparatus if there is danger therefrom, and to prevent any conductor or apparatus from being accidentally or inadvertently electrically charged when persons are working thereon.
- (2) Every person who is working on an electric supply line or apparatus or both shall be provided with tools and devices such as gloves, rubber shoes, safety belts, ladders, earthing devices, helmets, line testers, hand lines and the like for protecting him from mechanical and electrical injury and such tools

and devices shall always be maintained in sound and efficient working condition.

- (3) No person shall work on any live electric supply line or apparatus and no person shall assist such person on such work, unless he is designated in that behalf, and takes the safety precautions given in Schedule-III.
- (4) Every telecommunication line on supports carrying a line of voltage exceeding 650 V but not exceeding 33 kV shall, for the purpose of working thereon, be deemed to be a line of voltage exceeding 650 V.
- (5) All non-current carrying metal parts of switchgear and control panels shall be properly earthed and insulating floors or mat conforming to IS-15652:2006, of appropriate voltage level shall be provided in front of panels for the safety of operating personnel.
- (6) All panels shall be painted with the description of its identification at front and at the rear.

Regulation 22, Cables protected by bituminous materials

- (1) Where the supplier or the owner has brought into use an electric supply line, other than an overhead line, which is not completely enclosed in a continuous metallic covering connected with earth and is insulated or protected in situ by composition or material of a bituminous character, —
 - (i) any pipe, conduit, or the like into which such electric supply line may have been drawn or placed shall, unless other arrangements are approved by the Electrical Inspector in any particular case, be effectively sealed at its point of entry into any street box so as to prevent any flow of gas to or from the street box, and;
 - (ii) such electric supply line shall be periodically inspected and tested where accessible, and the result of each such inspection and test shall be duly recorded by the supplier or the owner.
- (2) The supplier or the owner after the coming into force of these regulations, shall not bring into use any further electric supply line as aforesaid which is insulated or protected in situ by a composition or material known to be liable to produce noxious or explosive gases on excessive heating.

Regulation 23, Street boxes

- (1) Street boxes shall not contain gas pipes, and precautions shall be taken to prevent, as far

as reasonably possible, any influx of water or gas.

- (2) Where electric supply lines forming part of different systems pass through the same street box, they shall be readily distinguishable from one another and all electric supply lines of voltage exceeding 650 V at or in street boxes shall be adequately supported and protected so as to prevent risk of damage to or danger from adjacent electric supply lines.
- (3) All street boxes shall be regularly inspected for the purpose of detecting the presence of gas and if any influx or accumulation is discovered, the owner shall give immediate notice to any authority or company who have gas mains in the neighbourhood of the street box and in cases where a street box is large enough to admit the entrance of a person after the electric supply lines or apparatus therein have been placed in position, ample provision shall be made —
 - (i) to ensure that any gas which may be accident have obtained access to the box shall escape before a person is allowed to enter; and
 - (ii) for the prevention of danger from sparking.
- (4) The owners of all street boxes or pillars containing circuits or apparatus shall ensure that their covers and doors are kept closed and locked and are so provided that they can be opened only by means of a key or a special appliance.

Regulation 24, Distinction of different circuits

The owner of every generating stations, substation, junction-box or pillar in which there are any circuits or apparatus, whether intended for operation at different voltages or at the same voltage, shall ensure by means of indication of a permanent nature that the respective circuits are readily distinguishable from one another.

Regulation 25, Distinction of the installations having more than one feed

The owner of every installation including substation, double pole structure, four pole structure or any other structure having more than one feed, shall ensure by means of indication of a permanent nature, that the installation is readily distinguishable from other installations.

Regulation 26, Accidental charging

- (1) The owners of all circuits and apparatus shall so arrange them that there shall be no danger

of any part thereof becoming accidentally charged to any voltage beyond the limits of voltage for which they are intended.

- (2) Where alternating current and direct current circuits are installed on the same box or support, they shall be so arranged and protected that they shall not come into contact with each other when live.

Regulation 27, Provisions applicable to protective equipment

- (1) Fire buckets filled with clean dry sand and ready for immediate use for extinguishing fires, in addition to fire extinguishers suitable for dealing with fires, shall be conspicuously marked fire extinguishers suitable for dealing with fires, shall be conspicuously marked and kept in all generating stations, enclosed substations and switching-stations in convenient locations.
- (2) The fire extinguishers shall be tested for satisfactory operation as per relevant Indian Standard at least once a year and record of such tests shall be maintained.
- (3) First-aid boxes or cupboards conspicuously marked and equipped with such contents as the State Government may specify, shall be provided and maintained in every generating station, enclosed substation, enclosed switching station and in vehicles used for maintenance of lines so as to be readily accessible during all working hours and all such boxes and cupboards shall, except in the case of unattended substations and switching stations, be kept in charge of responsible persons who are trained in first-aid treatment and one of such persons shall be available during working hours.
- (4) Two or more gas masks shall be provided conspicuously and installed and maintained at accessible places in every generating station with capacity of 5 MW and above and enclosed substation with transformation capacity of 5 MVA and above for use in the event of fire or smoke.

Provided that where more than one generator with capacity of 5 MW and above is installed in a power station, each generator shall be provided with at least two separate gas masks in an accessible and conspicuous place.

Provided further that adequate number of gas masks shall be provided by the owner at every generating station and enclosed substation with capacity less than 5 MW and 5 MVA respectively.

Regulation 28, Display of instructions for resuscitation of persons suffering from electric shock

- (1) Instructions, in English or Hindi and the local language of the District and where Hindi is the local language, in English and Hindi for the resuscitation of persons suffering from electric shock, shall be affixed by the owner in a conspicuous place in every generating station, enclosed substation, enclosed switching station, mines and in every factory, as defined in clause (m) of section 2 of the *Factory Act, 1948* (63 of 1948) in which electricity is used and in such other premises where electricity is used as the Electrical Inspector may, by notice in writing served on the owner, direct.
- (2) The owner of every generating station, enclosed substation, enclosed switching station and every factory or other premises to which these regulations apply, shall ensure that all designated persons employed by him are acquainted with and are competent to apply the instructions referred to in sub-regulation (1).
- (3) In every manned generating station, substation or switching station of voltage exceeding 650 V, an artificial respirator shall be provided and kept in good working condition.

Regulation 29, Precautions to be adopted by consumers, owners, occupiers, electrical contractors, electrical workmen and suppliers

- (1) No electrical installation work, including additions, alternations, repairs and adjustments to existing installations, except such replacement of lamps, fans, fuses, switches, domestic appliances of voltage not exceeding 250 V and fittings as in no way alters its capacity or character, shall be carried out upon the premises of or on behalf of any consumer, supplier, owner or occupier for the purpose of supply to such consumer, supplier, owner or occupier except by an electrical contractor licensed in this behalf by the State Government and under the direct supervision of a person holding a certificate of competency and by a person holding a permit issued or recognized by the State Government.

Provided that in the case of works executed for or on behalf of the Central Government and in the case of installations in mines, oil fields and railways, the Central Government and in other cases the State Government, may, by notification in the Official Gazette, exempt

on such conditions as it may impose, any such work described therein either generally or in the case of any specified class of consumers, suppliers, owners or occupiers.

- (2) No electrical installation work which has been carried out in contravention of sub-regulation (1) shall either be energized or connected to the works of any supplier.

Regulation 30, Periodical inspection and testing of installations

- (1) Where an installation is already connected to the supply system of the supplier or trader, every such installation shall be periodically inspected and tested at intervals not exceeding five years either by the Electrical Inspector or by the supplier as may be directed by the State Government in this behalf or in the case of installations belonging to, or under the control of the Central Government, and in the case of installation in mines, oilfields and railways, by the Central Government.
- (2) The periodical inspection and testing of installations of voltage equal to or below the notified voltage belonging to the supplier or consumer, shall be carried out by the supplier or owner or consumer and shall be self-certified.
- (3) The periodical inspection and testing of installations of voltage above the notified voltage belonging to the supplier or consumer shall be carried out by the Electrical Inspector: Provided that the supplier or owner or consumer has the option to get his installation inspected and tested by the Electrical Inspector of the Appropriate Government. Provided further that the electrical installations of mines, oil-fields and railways shall be periodically inspected and tested by the Electrical Inspector of the Appropriate Government.
- (4) Where the supplier is directed by the Central Government or the State Government, as the case may be, to inspect and test the installation, such supplier shall report on the condition of the installation to the consumer concerned in the Forms I, II and III as specified in Schedule-IV and shall submit a copy of such report to the Electrical Inspector.
- (5) The Electrical Inspector may, on receipt of such report, accept the report submitted by the supplier or record variations as the circumstances of each case may require and may recommend that the defects may be rectified as per report.

- (6) In the event of the failure of the owner of any installation to rectify the defects in his installation pointed out by the Electrical Inspector in his report and within the time indicated therein, such installation shall be liable to be disconnected under the directions of the Electrical Inspector after serving the owner of such installation with a notice for a period not less than forty eight hours:

Provided that the installation shall not be disconnected in case an appeal is made under sub section (2) of section 162 of the Act and the appellate authority has stayed the orders of disconnection.

- (7) It shall be the responsibility of the owner of all installations to maintain and operate the installation in a condition free from danger and as recommended by the manufacturer or by the relevant codes of practice of the Bureau of Indian Standards.

Regulation 31, Testing of consumer's installation

- (1) Upon receipt of an application for a new or additional supply of electricity and before connecting the supply or reconnecting the same after a period of six months, the supplier shall either test the installation himself or accept the test results submitted by the consumer when the same has been duly signed by the licensed Electrical Contractor.
- (2) The supplier shall maintain a record of test results obtained at each supply point to a consumer, in a Schedule-V.
- (3) If as a result of such inspection and test, the supplier is satisfied that the installation is likely to be dangerous, he shall serve on the applicant a notice in writing requiring him to make such modifications as are necessary to render the installation safe and may refuse to connect or reconnect the supply until the required modifications have been completed.

Regulation 32, Installation and testing of generating units

The capacity above which generating units including generating units producing electricity from renewable sources of energy will be required to be inspected by the Electrical Inspector before commissioning, shall be as per the notification to be issued by the Appropriate Government, under the sub-section (1) of section 162 of the Act.

Regulation 33, Precautions against leakage before connection

- (1) The supplier shall not connect with his works

the installation or apparatus on the premises of any applicant for supply unless he is reasonably satisfied that the connection will not at the time of making the connection cause a leakage from that installation or apparatus of a magnitude detrimental to safety which shall be checked by measuring the installation resistance as under, -

- (i) all equipment shall have the insulation resistance (IR) value as stipulated in the relevant Indian Standards;
 - (ii) on application of 500 V d.c. between each live conductor and earth for a period of one minute the insulation resistance of installation and equipment of voltage not exceeding 650 V shall be at least 1 MEGA OHM or as specified in the relevant Indian Standard;
 - (iii) on application of 2.5 kV d.c. between each live conductor and earth for a period of one minute, the insulation resistance of installation and equipment of voltage exceeding 650 V but not exceeding 33 kV shall be at least 5 MEGA OHM or as specified in the relevant standard;
- (2) If the supplier declines to make a connection under the provision of sub-regulation (1) he shall convey to the applicant the reasons in writing for so declining.

Regulation 34, Leakage on consumer's premises

- (1) If the Electrical Inspector or the supplier has reasons to believe that there is leakage in the system of a consumer which is likely to affect injuriously the use of electricity by the supplier or by other persons, or which is likely to cause danger, he may give the consumer notice in writing that he desires to inspect and test the consumer's installation.
- (2) If on such notice being given the consumer does not give all reasonable facilities for inspection and testing of his installation, or when an insulation resistance of the consumer's installation is so low as to prevent safe use of electricity, the supplier may, and if directed so to do by the Electrical Inspector shall discontinue the supply of electricity to the installation but only after giving to the consumer forty eight hours notice in writing of disconnection of supply and shall not recommence the supply until he or the Electrical Inspector is satisfied that the cause of the leakage has been removed.

Regulation 35, Supply and use of electricity

- (1) The electricity shall not be supplied, transformed, converted, inverted or used or continued to be supplied, transformed, converted, inverted or used unless the conditions contained in sub-regulations (2) to (8) are complied with.
- (2) The following controls of requisite capacity to carry and break the current shall be placed as near as possible after the point of commencement of supply so as to be readily accessible and capable of being easily operated to completely isolate the supply to the installation, such equipment being in addition to any equipment installed for controlling individual circuits or apparatus, namely—
 - (i) a linked switch with fuse or a circuit breaker by consumers of voltage which does not exceed 650 V;
 - (ii) a linked switch with fuse or a circuit breaker by a consumer of voltage exceeding 650 V but not exceeding 33 kV having aggregate installed transformer or apparatus capacity up to 1000 kVA to be supplied at voltage upto 11 kV and 2500 kVA at higher voltages (above 11 kV and not exceeding 33 kV);
 - (iii) a circuit breaker by consumers at voltage exceeding 650 V but not exceeding 33 kV having an aggregate installed transformer and apparatus capacity above 1000 kVA and supplied at voltage upto 11 kV and above 2500 kVA at higher voltages (above 11 kV and not exceeding 33 kV);
 - (iv) a circuit breaker by a consumer of voltage exceeding 33 kV.

Provided that where the point of commencement of supply and the consumer apparatus are near each other, one linked switch with fuse or circuit breaker near the point of commencement of supply shall be considered sufficient.

- (3) In case of every transformer the following shall be provided; namely—
 - (i) on primary side of transformers a linked switch with fuse or circuit breaker of adequate capacity:

Provided that the linked switch on the primary side of the transformer may be of such capacity as to carry the full load current and to break only the magnetising current of the transformer:

Provided further that for all transformers:

- (a) having a capacity of 5000 kVA and above installed before the year 2000; and
- (b) having a capacity 1000 kVA and above installed in or after the year 2000,

a circuit breaker shall be provided:

Provided also that the linked switch on the primary side of the transformer shall not be required for the unit auxiliary transformer and generator transformer;

- (ii) in respect of all transformers installed in or after the year 2000, on the secondary side of all transformers a circuit breaker of adequate rating shall be installed:

Provided that for suppliers' transformers of capacity below 1000 kVA, a linked switch with fuse or circuit breaker of adequate rating shall be installed on secondary side.

- (4) Except in the case of composite control gear designed as a unit each distinct circuit is to be protected against excess energy by means of suitable cut-out or a circuit breaker of adequate breaking capacity suitably located and so constructed as to prevent danger from overheating, arcing or scattering of hot metal when it comes into operation and to permit for ready renewal of the fusible metal of the cut-out without danger.
- (5) The supply of electricity to each motor or a group of motors or other apparatus meant for operating one particular machine shall be controlled by a suitable linked switch or a circuit breaker or an emergency tripping device with manual reset of requisite capacity placed in such a position as to be adjacent to the motor or a group of motors or other apparatus readily accessible to and easily operated by person incharge and so connected in the circuit that by its means all supply of electricity can be cut off from the motor or group of motors or apparatus from any regulating switch, resistance of other device associated therewith.
- (6) All insulating materials shall be chosen with special regard to the circumstances of their proposed use and their mechanical strength shall be sufficient for their purpose and so far as is practicable of such a character or so protected as to maintain adequately their insulating property under all working conditions in respect of temperature and moisture; and

- (7) Adequate precautions shall be taken to ensure that no live parts are so exposed as to cause danger.
- (8) Every consumer shall use all reasonable means to ensure that where electricity is supplied by a supplier no person other than the supplier shall interfere with service lines and apparatus placed by the supplier on the premises of the consumer.

Regulation 36, Provisions for supply and use of electricity in multi-storeyed building more than 15 metres in height

- (1) The connected load and voltage of supply above which inspection is to be carried out by an Electrical Inspector for a multi-storeyed building of more than fifteen meters height shall be notified by the Appropriate Government.
- (2) Before making an application for commencement of supply or recommencement of supply after an installation has been disconnected for a period of six months or more, the owner or occupier of a multi-storeyed building shall give not less than thirty days notice in writing to the Electrical Inspector specify therein the particulars of installation and the supply of electricity shall not be commenced or recommenced within this period, without the approval in writing of the Electrical Inspector.
- (3) The supplier or owner of the installation shall provide at the point of commencement of supply a suitable isolating device with cut-out or breaker to operate on all phases except neutral in the 3-phase, 4-wire circuit and fixed in a conspicuous position at not more than 1.70 metres above the ground so as to completely isolate the supply to the building in case of emergency.
- (4) The owner or occupier of a multi-storeyed building shall ensure that electrical installations and works inside the building are carried out and maintained in such a manner as to prevent danger due to shock and fire hazards, and the installations is carried out in accordance with the relevant codes of practice.
- (5) No other service pipes and cables shall be taken along the ducts provided for laying power cables and all ducts provided for power cables and other services shall be provided with fire barrier at each floor crossing.

Regulation 37, Conditions applicable to installations of voltage exceeding 250 Volts

The following conditions shall be compiled with where

electricity of voltage above 250 V is supplied, converted, transformed or used, namely—

- (i) All conductors, other than those of overhead lines, shall be completely enclosed in mechanically strong metal casing or metallic covering which is electrically and mechanically continuous and adequately protected against mechanical damage unless the said conductors are accessible only to an designated person or are installed and protected so as to prevent danger:
Provided that non-metallic conduits conforming to the relevant Indian Standard Specifications may be used for installations of voltage not exceeding 650 V:
- (ii) All metal works, enclosing, supporting or associated with the installation, other than that designed to serve as a conductor shall be connected with an earthing system as per standards laid down in the Indian Standards in this regard and the provisions of regulation 41.
- (iii) Every switchboard shall comply with the following—
 - (a) a clear space of not less than one metre in width shall be provided in front of the switchboard;
 - (b) if there are any attachments or bare connections at the back of the switchboard, the space, if any, behind the switchboard shall be either less than twenty centimetres or more than seventy five centimetres in width, measured from the farthest protruding part of any attachment or conductor;
 - (c) if the space behind the switchboard exceeds seventy five centimetres in width, there shall be a passage way from either end of the switchboard, clear to a height of 1.8 m.
- (iv) In case of installations provided in premises where inflammable materials including gases and chemicals are produced, handled or stored, the electrical installations, equipment and apparatus shall comply with the requirements of flame proof, dust tight, totally enclosed or any other suitable type of electrical fittings depending upon the hazardous zones as per the relevant Indian Standard Specifications.
- (v) Where an application has been made to a supplier for supply of electricity to any installation, he shall not commence the supply or where the supply has been discontinued for

a period of six months and above, recommence the supply unless the consumer has complied with, in all respects the conditions of supply set out in these regulations.

- (vi) Where a supplier proposes to supply or use electricity at or to recommence supply of voltage exceeding 250 V but not exceeding 650 V after it has been discontinued for a period of six months, he shall, before connecting or reconnecting the supply, give notice in writing of such intention to the Electrical Inspector.
- (vii) If at any time after connecting the supply, the supplier is satisfied that any provision of these regulations are not being observed he shall give notice of the same in writing to the consumer and the Electrical Inspector, specifying how the provisions have not been observed and to rectify such defects in a reasonable time and if the consumer fails to rectify such defects pointed out, he may discontinue the supply after giving the consumer a reasonable opportunity of being heard and recording reasons in writing and the supply shall be discontinued only on written orders of an officer duly notified by the supplier in this behalf and shall be restored with all possible speed after such defects are rectified by the consumer to the satisfaction of the supplier.

Regulation 39, Precautions against failure of supply and notice of failures

- (1) The layout of the electric supply lines of the supplier for the supply of electricity throughout his area of supply shall under normal working conditions be sectionalised and so arranged, and provided with switchgear or circuit-breakers, so located, as to restrict within reasonable limits the extent of the portion of the system affected by any failure of supply.
- (2) The supplier shall take all reasonable precautions to avoid any accidental interruptions of supply, and also to avoid danger to the public or to any employee or designated person when engaged on any operation during and in connection with the installation, extension, replacement, repair and maintenance of any works.
- (3) The supplier shall send to the Electrical Inspector a notice of failure of supply of such kind as the Electrical Inspector may from time-to-time require to be notified to him, and such

notice shall be sent by the earliest mode of communication after the failure occurs or after the failure becomes known to the supplier and shall be in the Form given in Schedule-VI.

- (4) For the purpose of testing or for any other purpose connected with the efficient working of the supplier's installations, the supply of electricity may be discontinued by the supplier for such period as may be necessary, subject to not less than twenty four hours notice being given by the supplier to all consumers likely to be affected by such discontinuance:

Provided that no such notice shall be given in cases of emergency.

Regulation 40, Test for resistance of insulation

- (1) Where any electric supply line for use at voltage not exceeding 650 V has been disconnected from a system for the purpose of addition, alteration or repair, such electric supply line shall not be reconnected to the system until the supplier or the owner has applied the test prescribed under regulation 33.
- (2) The provision under sub-regulation (1) shall not apply to overhead lines except overhead insulated cables, unless the Electrical Inspector otherwise directs in any particular case.

Regulation 41, Connection with earth

The following condition shall apply to the connection with earth of systems at voltage normally exceeding 125 V but not exceeding 650 V, namely—

- (i) neutral conductor of a 3-phase, 4-wire system and the middle conductor of a 2-phase, 3-wire system shall be earthed by not less than two separate and distinct connections with a minimum of two different earth electrodes or such large number as may be necessary to bring the earth resistance to a satisfactory value both at the generating station and at the substation.
- (ii) the earth electrodes so provided, shall be interconnected to reduce earth resistance.
- (iii) neutral conductor shall also be earthed at one or more points along the distribution system or service line in addition to any connection with earth which may be at the consumer's premises.
- (iv) in the case of a system comprising electric supply lines having concentric cables, the external conductor of such cables shall be earthed by two separate and distinct connections with earth.

- (v) the connection with earth may include a link by means of which the connection may be temporarily interrupted for the purpose of testing or for locating a fault.
- (vi) in a direct current three wire system, the middle conductor shall be earthed at the generating station only, and the current from the middle conductor to earth shall be continuously recorded by means of a recording ammeter, and if at any time the current exceeds one-thousandth part of the maximum supply current, immediate steps shall be taken to improve the insulation of the system.
- (vii) where the middle conductor is earthed by means of a circuit breaker with a resistance connected in parallel, the resistance shall not exceed ten ohms and on the opening of the circuit breaker, immediate steps shall be taken to improve the insulation of the system, and the circuit breaker shall be reclosed as soon as possible.
- (viii) the resistance shall be used only as a protection for the ammeter in case of earths on the system and until such earths are removed and immediate steps shall be taken to locate and remove the earth.
- (ix) in the case of an alternating current system, there shall not be inserted in the connection with earth any impedance, other than that required solely for the operation of switchgear or instruments, cut-out or circuit breaker, and the result of any test made to ascertain whether the current, if any, passing through the connection with earth is normal, shall be duly recorded by the supplier.
- (x) no person shall make connection with earth by the aid of, nor shall he keep it in contact with, any water mains not belonging to him except with the consent of the owner thereof and of the Electrical Inspector.
- (xi) alternating current systems which are connected with earth as aforesaid shall be electrically interconnected:
Provided that each connection with earth is bonded to the metal sheathing and metallic armouring, if any, of the electric supply lines concerned.
- (xii) the frame of every generator, stationary motor, portable motor, and the metallic parts, not intended as conductors, of all transformers and any other apparatus used for regulating or controlling electricity, and all electricity consuming apparatus, of voltage exceeding 250 V but not exceeding 650 V shall be

earthed by the owner by two separate and distinct connections with earth.

(xiii) neutral point of every generator and transformer shall be earthed by connecting it to the earthing system by not less than two separate and distinct connections.

(xiv) all metal casing or metallic coverings containing or protecting any electric supply line or apparatus shall be connected with earth and shall be so joined and connected across all junction boxes and other openings as to make good mechanical and electrical connection throughout their whole length:

Provided that conditions mentioned in this regulation shall not apply, where the supply voltage does not exceed 250 V and the apparatus consists of wall tubes or brackets, electroliers, switches, ceiling fans or other fittings, other than portable hand lamps and portable and transportable apparatus, unless provided with earth terminal and to class-II apparatus and appliances:

Provided further that where the supply voltage is not exceeding 250 V and where the installations are either new or renovated, all plug sockets shall be of the three pin type, and the third pin shall be permanently and efficiently earthed.

(xv) All earthing systems shall —

(a) consist of equipotential bonding conductors capable of carrying the prospective earth fault current and a group of pipes, rods and plate electrodes for dissipating the current to the general mass of earth without exceeding the allowable temperature limits as per relevant Indian Standards in order to maintain all non-current carrying metal works reasonably at earth potential and to avoid dangerous contact potentials being developed on such metal works;

(b) limit earth resistance sufficiently low to permit adequate fault current for the operation of protective devices in time and to reduce neutral shifting;

(c) be mechanically strong, withstand corrosion and retain electrical continuity during the life of the installation and all earthing systems shall be tested to ensure efficient earthing, before the electric supply lines or apparatus are energised.

(xvi) all earthing systems belonging to the supplier shall in addition, be tested for resistance on dry day during the dry season not less than once every two years.

(xvii) a record of every earth test made and the result thereof shall be kept by the supplier for a period of not less than two years after the day of testing and shall be available to the Electrical Inspector when required.

Explanation — The expression “Class-II apparatus and appliance” shall have the same meaning as is assigned to it in the relevant Indian Standards.

Regulation 42, Earth leakage protective device

The supply of electricity to every electrical installation other than voltage not exceeding 250 V, below 2 kW and those installations of voltage not exceeding 250 V, which do not attract provisions of section 54 of the Act, shall be controlled by an earth leakage protective device whose maximum earth leakage threshold for tripping should not exceed 30 milliamps for domestic connections and 100 milliamps for all other installations, so as to disconnect the supply instantly on the occurrence of earth fault or leakage of current:

Provided that such earth leakage protective device shall not be required for overhead supply lines having protective devices which are effectively bonded to the neutral of supply transformers and conforming to regulation 73.

Regulation 43, Approval by electrical inspector and self-certification

(1) Every electrical installation of notified voltage and below shall be inspected, tested and shall be self-certified by the owner of the installation before commencement of supply or recommencement after shutdown for six months and above for ensuring observance of safety measures specified under these regulations and such owner shall submit the report of self-certification in the Form-I or Form-II or Form-III, as the case may be, of Schedule-IV to the Electrical Inspector.

(2) The voltage above which inspection and testing of electrical installations including installations of supplier or consumer shall be carried out by the Electrical Inspector shall be notified by the Appropriate Government.

(3) Every electrical installation of voltage above the notified voltage and all the apparatus of the generating stations and above the capacity specified under regulation 32, shall be required to be inspected and tested by the Electrical Inspector before commencement of supply or recommencement after shutdown for six months and above for ensuring observance of safety measures specified under these regulations:

Provided that the owner or supplier or

consumer has the option to get his installation inspected and tested by the Electrical Inspector of the Appropriate Government.

- (4) The Electrical Inspector may, on receipt of self-certification report referred to in sub-regulation (1), accept the report submitted by the supplier or owner and record variations as the circumstances of each case may require and may recommend that the defects may be rectified as recommended:

Provided further that every electrical installation covered under section 54 of the Act including every electrical installations of mines, oil fields and railways shall be inspected and tested by the Electrical Inspector of the Appropriate Government as specified in sub-regulation (3).

- (5) Before making an application to the Electrical Inspector for permission to commence or recommence supply in installations above the notified voltage after an installation has been disconnected for six months, the supplier shall ensure that electric supply lines or apparatus of more than notified voltage belonging to him are placed in position, properly joined and duly completed and examined, and the supply of electricity shall not be commenced by the supplier for installations of voltage needing inspection under these regulations unless the provisions of regulations 12 to 29, 33 to 35, 44 to 51 and 55 to 77 have been complied with and the approval in writing of the Electrical Inspector has been obtained by him:

Provided that the supplier may energise the aforesaid electric supply lines or apparatus for the purpose of tests specified in regulation 46 and after successful testing, the owner may energise the section of a line to prevent theft of conductors or towers, subject to compliance of all the provisions of these regulations.

- (6) The owner of any installations of voltage above the notified voltage, shall, before making application to the Electrical Inspector for approval of his installation or additions thereto, other than an overhead line, and satisfy himself that they withstand the application of the testing voltage set out in sub-regulation (1) of regulation 46 and shall duly record the results of such tests and forward them to the Electrical Inspector:

Provided that an Electrical Inspector may direct such owner to carry out such tests as he deems necessary or accept the certified tests of the manufacturer in respect of any particular apparatus in place of the tests required by this regulation.

- (7) The owner of any installation who makes any addition or alternation to his installation shall not connect to the supply his apparatus or electric supply lines, comprising the said alternations or additions, unless and until such alteration or addition has been approved in writing by the Electrical Inspector or self-certified by the owner of the installation, as the case may be.

Regulation 44, Use of electricity at voltage exceeding notified voltage

- (1) The Electrical Inspector shall not authorize the supplier to commence supply or where the supply has been discontinued for a period of six months and above, to recommence the supply at voltage exceeding notified voltage to any consumer unless—

(i) all conductors and apparatus situated on the premises of the consumer are so placed as to be inaccessible except to a designated person and all operations in connection with the said conductors and apparatus are carried out by a designated person;

(ii) the consumer has provided and agrees to maintain a separate building or a locked weather proof and fire proof enclosure of agreed design and location, to which the supplier at all times shall have access for the purpose of housing his apparatus and metering equipment, or where the provision for a separate building or enclosure is impracticable, the consumer has segregated the aforesaid apparatus of the supplier from any other part of his own apparatus:

Provided that such segregation shall be by the provision of fire proof walls, if the Electrical Inspector considers it to be necessary:

Provided further that in the case of an outdoor installation the consumer shall suitably segregate the aforesaid apparatus belonging to the supplier from his own;

(iii) all pole type substations are constructed and maintained in accordance with regulation 50.

- (2) The owner shall observe the following conditions, where electricity at voltage exceeding 650 V is supplied, converted, transformed or used,—

(i) he shall maintain safety clearances for electrical apparatus as per Bureau of

- Indian Standard specification so that sufficient space is available for easy operation and maintenance without any hazard to the operating and maintenance personnel working near the equipment and for ensuring adequate ventilation;
- (ii) he shall not allow any encroachment below such installation:
Provided that where the Electrical Inspector comes across any such encroachment, he shall direct the owner to remove such encroachments;
- (iii) the minimum safety working clearances specified in Schedule-VII shall be maintained for the bare conductors or live parts of any apparatus in outdoor substations excluding overhead lines of installations of voltage exceeding 650 V;
- (iv) he shall ensure that the windings of motors or other apparatus within reach from any position in which a person may require to be, are suitably protected so as to prevent danger;
- (v) he shall ensure that where a transformer or transformers are used, suitable provision shall be made, either by connecting with earth, a point of the circuit at the lower voltage or otherwise, to guard against danger by reason of the said circuit becoming accidentally charged above its normal voltage by leakage from or contact with the circuit at the higher voltage;
- (vi) a substation or a switching station with apparatus having more than 2000 litres of oil shall not be located in the basement where proper oil draining arrangement cannot be provided;
- (vii) where a substation or a switching station with apparatus having more than 2000 litres of oil is installed, whether indoor or outdoors, he shall take the following measures, namely—
- (a) the baffle walls of four hours fire rating shall be provided between the apparatus,—
- (i) where there is a single phase transformer banks in the switchyards of generating stations and substations;
- (ii) on the consumer premises;
- (iii) where adequate clearance between the units is not available.
- (b) provisions shall be made for suitable oil soakpit and where use of more than 9000 litres of oil in any one oil tank, receptacle or chamber is involved, provision shall be made for the draining away or removal of any oil which may leak or escape from the tank, receptacle or chamber containing the same, and special precautions shall be taken to prevent the spread of any fire resulting from the ignition of the oil from any cause and adequate provision shall be made for extinguishing any fire which may occur;
- (c) spare oil shall not be stored in the vicinity of any oil filled equipment in any such substation or switching station;
- (d) all the transformers and switchgears shall be maintained in accordance with the maintenance schedules prepared in accordance with the relevant codes of practice of Bureau of Indian Standards;
- (e) dry type of transformers only shall be used for installations inside the residential and commercial buildings;
- (viii) without prejudice to the above measures, he shall take adequate fire protection arrangement for quenching the fire in the apparatus;
- (ix) he shall ensure that the transformers of 10 MVA and above rating or in case of oil filled transformers with oil capacity of more than 2000 liters are provided with fire fighting system as per IS-3034:1993 or with Nitrogen Injection Fire Protection system;
- (x) where it is necessary to locate the substation, or switching station in the basement, he shall take the following measures, namely—
- (a) the room shall necessarily be in the first basement at the periphery of the basement;
- (b) the entrances to the room shall be provided with the fire resisting doors of 2 hour fire rating and the door shall always be kept closed and a notice of this effect shall be affixed on outer side of the door;
- (c) a curb (sill) of a suitable height shall be provided at the entrance in order to prevent the flow of oil from a

- ruptured transformer into other parts of the basement;
- (d) direct access to the transformer room shall be provided from outside and the surrounding walls shall be lined with fire bricks;
 - (e) the cables to primary side and secondary side shall have sealing at all floors and wall opening of at least two hours rating;
 - (f) Fire Retardant Low Smoke (FRLS) cable of two hours rating shall be used.
- (xi) he shall ensure that oil filled transformers installed indoors in other than residential or commercial buildings are placed at the ground floor or not below the first basement;
 - (xii) he shall ensure that cable trenches inside the substations and switching stations containing cables are filled with sand, pebbles or similar non-inflammable materials or completely covered with non-inflammable slabs;
 - (xiii) he shall ensure that unless the conditions are such that all the conductors and apparatus may be made dead at the same time for the purpose of cleaning or for other work, the said conductors and apparatus shall be so arranged that these may be made dead in sections, and that work on any such section may be carried on by a designated person without danger;
 - (xiv) only persons designated under sub-regulation (1) of regulation 3, shall carry out the work on live lines and apparatus.
- (3) All apparatus shall be protected against lighting and apparatus exceeding 220 kV shall also be protected against switching over voltages.
 - (4) The equipment used for protection and switching shall be adequately co-ordinated with the protected apparatus to ensure safe operation and to maintain the stability of the inter-connected units of the power system.
 - (5) The minimum clearance specified in Schedule-VIII shall be maintained for bare conductors or live parts of any apparatus in outdoor substations, excluding overhead lines of High Voltage Direct Current installations.
 - (6) There shall not be tapping of another transmission line from the main line for 66 kV and above class of lines.

Regulation 45, Inter-locks and protection for use of electricity at voltage exceeding 650 volts

- (1) The owner shall ensure the following namely—
 - (i) isolators and the controlling circuit breakers shall be inter-locked so that the isolators cannot be operated unless the corresponding breaker is in open position.
 - (ii) isolators and the corresponding earthing switches shall be inter-locked so that no earthing switch can be closed unless and until the corresponding isolator is in open position;
 - (iii) where two or more supplies are not intended to be operated in parallel, the respective circuit breakers or linked switches controlling the supplies shall be inter-locked to prevent possibility of any inadvertent paralleling or feedback;
 - (iv) when two or more transformers are operated in parallel, the system shall be so arranged as to trip the secondary breaker of a transformer in case the primary breaker of that transformer trips;
 - (v) all gates or doors which give access to live parts of an installation shall be inter-locked in such a way that these cannot be opened unless the live parts are made dead and proper discharging and earthing of these parts should be ensured before any person comes in close proximity of such parts;
 - (vi) where two or more generators operate in parallel and neutral switching is adopted, inter-lock shall be provided to ensure that generator breaker cannot be closed unless one of the neutrals is connected to the earthing system.
- (2) The following protection shall be provided in all systems and circuits to automatically disconnect the supply under abnormal conditions, namely—
 - (i) over current protection to disconnect the supply automatically if the rated current of the equipment, cable or supply line is exceeded for a time which the equipment, cable or supply line is not designed to withstand;
 - (ii) earth fault or earth leakage protection to disconnect the supply automatically if the earth fault current exceeds the limit of current for keeping the contact potential within the reasonable values;
 - (iii) gas pressure type and winding and oil temperature protection to give alarm and

- tripping shall be provided on all transformers of rating 1000 kVA and above;
- (iv) transformers of capacity 10 MVA and above shall be protected against incipient faults by differential protection;
 - (v) all generators with rating of 100 kVA and above shall be protected against earth fault or leakage;
 - (vi) all generators of rating 1000 kVA and above shall be protected against fault within the generator winding using restricted earth fault protection or differential protection or by both;
 - (vii) high speed bus bar differential protection along with local breaker back up protection shall be commissioned and shall always be available at all 132 kV and above voltage substations and switching stations and generating stations connected with the grid:
Provided that in respect of existing 132 kV substations and switching stations having more than one incoming feeders, the high speed bus bar differential protection along with local breaker back up protection, shall be commissioned and shall always be available;
 - (viii) every generating station and substation connected to the grid at 220 kV and above shall be provided with disturbance recording and event logging facilities and all such equipment shall be provided with time synchronization facility for global common time reference but wherever numerical relays with provision of recording fault data are installed, disturbance recorder and event logger may not be installed;
 - (ix) distance protection and carrier communication protection shall be provided for all lines connecting to 400/220 kV substation.

Regulation 46, Testing, operation and maintenance

- (1) Before approval is accorded by the Electrical Inspector under regulation 43 the manufacturer's test certificates shall, if required, be produced for all the routine tests as required under the relevant Indian standards.
- (2) No new apparatus, cable or supply line of voltage exceeding 650 Volts shall be commissioned unless such apparatus, cable or supply line are subjected to site tests as per relevant code of practice of the Bureau of

Indian Standards.

- (3) No apparatus, cable or supply line of voltage exceeding 650 V which has been kept disconnected, for a period of six months or more, from the system for alterations or repair, shall be connected to the system until such apparatus, cable or supply line are subjected to the relevant tests as per code of practice of Bureau of Indian Standards.
- (4) Notwithstanding the provisions of this regulation, the Electrical Inspector may require certain tests to be carried out before or after charging the installations.
- (5) All apparatus, cables and supply lines shall be maintained in healthy conditions and tests shall be carried out periodically as per the relevant code of practice of the Bureau of Indian Standards.
- (6) Records of all tests, trippings, maintenance works and repairs of all equipment cables and supply lines shall be duly kept in such a way that these records can be compared with earlier ones.
- (7) It shall be the responsibility of the owner of all installations of voltage exceeding 650 V to maintain and operate the installations in a condition free from danger and as recommended by the manufacturer or by the relevant codes of practice of the Bureau of Indian Standards.
- (8) Failures of transformers and reactors of 20 MVA or MVAR and higher capacity shall be reported by the consumer and the suppliers of electricity, within forty eight hours of the occurrence of the failure, to the Central Electricity Authority and the reasons for failure and measures to be taken to avoid recurrence of failure shall be sent to the Central Electricity Authority within one month of the occurrence in the format given in Schedule-IX.

Regulation 47, Precautions to be taken against excess leakage in case of metal sheathed electric supply lines

The following precautions shall be taken in case of electric supply lines other than overhead lines, for use at voltage exceeding 650 V; namely—

- (i) the conductors of the cable except the cable with thermoplastic insulation without any metallic screen or armour shall be enclosed in metal sheathing which shall be electrically continuous and connected with earth, and the

conductivity of the metal sheathing shall be maintained and reasonable precautions taken where necessary to avoid corrosion of the sheathing;

- (ii) the resistance of the earth connection with metallic sheath shall be kept low enough to permit the controlling circuit breaker or cut-out to operate in the event of any failure of insulation between the metallic sheath and the conductor.

Explanation — For the purpose of this regulation;

- (a) in the case of thermoplastic insulated and sheathed cables with metallic armour the metallic wire or tape armour, shall be considered as metal sheathing.
- (b) where an electric supply line as aforesaid has concentric cables and the external conductor is insulated from an outer metal sheathing and connected with earth, the external conductor may be regarded as the metal sheathing for the purpose of this regulation provided that the foregoing provisions as to conductivity are complied with.

Regulation 48, Connection with earth for apparatus exceeding 650 Volts

- (1) All non-current carrying metal parts associated with an installation of voltage exceeding 650 V shall be effectively earthed to a grounding system or mat which shall,
 - (i) limit the touch and step potential to tolerable values;
 - (ii) limit the ground potential rise to tolerable values so as to prevent danger due to transfer of potential through ground, earth wires, cable sheath, fences, pipe lines, etc;
 - (iii) maintain the resistance of the earth connection to such a value as to make operation of the protective device effective;
- (2) In the case of star connected system with earthed neutrals or delta connected system with earthed artificial neutral point —
 - (i) the neutral point of every generator and transformer shall be earthed by connecting it to the earthing system not by less than two separate and distinct connections:

Provided that the neutral point of a generator may be connected to the earthing system through an impedance to limit the fault current to the earth:

Provided further that in the case of multi-

machine systems neutral switching may be resorted to, for limiting the injurious effect of harmonic current circulation in the system;

- (ii) the generator or transformer neutral shall be earthed through a suitable impedance where an appreciable harmonic current flowing in the neutral connection causes interference, with communication circuits;
 - (iii) in case of the delta connected system the neutral point shall be obtained by the insertion of a grounding transformer and current limiting resistance or impedance wherever considered necessary at the commencement of such a system.
- (3) In case of generating stations, substations and industrial installations of voltage exceeding 33 kV, the system neutral earthing and protective frame earthing may be, if system design so warrants, integrated into common earthing grid provided the resistance to earth of combined mat does not cause the step and touch potential to exceed its permissible values.
 - (4) Single phase system of voltage exceeding 650 V shall be effectively earthed.
 - (5) In the case of a system comprising electric supply lines having concentric cables, the external conductor shall be connected with earth.
 - (6) Where a supplier proposes to connect with earth an existing system for use at voltage exceeding 650 V which has not hitherto been so connected with earth, he shall give not less than fourteen days notice in writing together with particulars of the proposed connection with earth to the telegraphy-authority established under the *Indian Telegraph Act, 1885* (13 of 1885).
 - (7) Where the earthing lead and earth connection are used only in connection with earthing guards erected under overhead lines of voltage exceeding 650 V where they cross a telecommunication line or a railway line, and where such lines are equipped with earth leakage, the earth resistance shall not exceed twenty five ohms and the project authorities shall obtain No Objection Certificate (NOC) from Railway Authorities and Power and Telecommunication Co-ordination Committee before energisation of the facilities.
 - (8) Every earthing system belonging to either the supplier or the consumer shall be tested for its resistance to earth on a dry day during dry

season not less than once a year and records of such tests shall be maintained and produced, if so required, before the Electrical Inspector.

Regulation 49, General conditions as to transformation and control of electricity

- (1) Where electricity of voltage exceeding 650 V is transformed, converted, regulated or otherwise controlled in substations or switching stations including outdoor substations and outdoor switching stations to be transformed or in street boxes constructed underground, the following provisions shall be observed, namely—
 - (i) substations and switching stations shall preferably be erected above ground, but where necessarily constructed underground due provisions for ventilation and drainage shall be made and any space housing switchgear shall not be used for storage of any materials especially inflammable and combustible materials or refuse;
 - (ii) outdoor substations except pole type substations and outdoor switching stations shall, unless the apparatus is completely enclosed in a metal covering connected with earth, the said apparatus also being connected with the system by armoured cables, be efficiently protected by fencing not less than 1.8 m in height or other means so as to prevent access to the electric supply lines and apparatus therein by an undesignated person and the fencing of such area shall be earthed efficiently;
 - (iii) underground street boxes, other than substations, which contain transformers shall not contain switches, cut-outs or other apparatus required for controlling or other purposes shall be fixed in separate receptacle above ground wherever practicable.
- (2) Where electricity is transformed, suitable connection shall be made by connecting with earth a point of the system at the lower voltage and also to guard against danger by reason of the said system becoming accidentally charged above its normal voltage by leakage from a contact with the system at the higher voltage.

Regulation 50, Pole type substations

Where platform type construction is used for a pole type substation and sufficient space for a person to stand on the platform is provided, a substantial hand rail shall be built around the said platform and if the hand rail is

of metal, it shall be connected with earth:

Provided that in the case of pole type substation on wooden supports and wooden platform the metal hand-rail shall not be connected with earth.

Regulation 52, Supply to luminous tube sign installations of voltage exceeding 650 Volts but not exceeding 33 kV

- (1) Any person who proposes to use or who is using electricity for the purpose of operating a luminous tube sign installation, or who proposes to transform or is transforming electricity to a voltage exceeding 650 V but not exceeding 33 kV for any such purpose shall comply with the following conditions, namely—
 - (i) all live parts of the installation, including all apparatus and live conductors in the secondary circuit, but excluding the tubes except in the neighbourhood of their terminals, shall be inaccessible to undesignated persons and such parts shall be effectively screened;
 - (ii) irrespective of the method of obtaining the voltage of the circuit which feeds the luminous discharge tube sign, no part of any conductor of such circuit shall be in metallic connection, except in respect of its connection with earth, with any conductor of the supply system or with the primary winding of the transformer;
 - (iii) all live parts of an exterior installation shall be so disposed as to protect them against the effects of the weather and such installations shall be so arranged and separated from the surroundings as to limit, as far as possible, the spreading of fire;
 - (iv) the secondary circuit shall be permanently earthed at the transformer and the core of every transformer shall be earthed;
 - (v) where the conductors of the primary circuit are not in metallic connection with the supply conductors, one phase of such primary circuit shall be permanently earthed at the motor generator or convertor, or at the transformer and an earth leakage circuit breaker of sufficient rating shall be provided on the side of voltage not exceeding 250 V to detect the leakage in such luminous tube sign installations;
 - (vi) a sub-circuit which forms the primary circuit of a fixed luminous discharge tube

- sign installation shall be reserved solely for such purpose;
 - (vii) a separate primary final sub-circuit shall be provided for each transformer or each group of transformers having an aggregate input not exceeding 1,000 volt-amperes, of a fixed luminous discharge tube sign installation;
 - (viii) an interior installation shall be provided with suitable adjacent means for disconnecting all phases of the supply except the “neutral” in a 3-phase, 4-wire circuit;
 - (ix) for installations on the exterior of a building a suitable emergency fire-proof linked switch to operate on all phases except the neutral in a 3-phase, 4-wire circuit shall be provided and fixed in a conspicuous position at not more than 1.70 metres above the ground.
 - (x) a special “caution” notice shall be affixed in a conspicuous place on the door of every enclosure of voltage exceeding 650 V but not exceeding 33 kV to the effect that the supply must be cut off before the enclosure is opened;
 - (xi) where static condensers are used, they shall be installed on the load side of the fuses and the primary side of the transformers where the voltage does not exceed 250 V;
 - (xii) where static condensers are used on primary side, provision shall be made for automatic or manual discharging of the condensers when the supply is cut-off;
 - (xiii) before using the static condensers or any interrupting device on the voltage exceeding 650 V, the executing agencies shall test and ensure that automatic discharging device is functional thereon.
- (2) The owner or user of any luminous tube sign or similar installation of voltage exceeding 650 V but not exceeding 33 kV shall not bring the same into use without giving to the Electrical Inspector not less than fourteen days notice in writing of his intention so to do.

Regulation 58, Clearance above ground of the lowest conductor of overhead lines

- (1) No conductor of an overhead line, including service lines, erected across a street shall at any part thereof be at a height of less than —
 - (i) for lines of voltage not exceeding 650 Volts

- (ii) for lines of voltage exceeding 650 Volts but not exceeding 33 kV - 6.1 metres
- (2) No conductor of an overhead line, including service lines, erected along any street shall at any part thereof be at a height less than-
- (i) for lines of voltage not exceeding 650 Volts - 5.5 metres
 - (ii) for lines of voltage exceeding 650 Volts but not exceeding 33 kV - 5.8 metres
- (3) No conductor of an overhead line including service lines, erected elsewhere than along or across any street shall be at a height less than—
- (i) for lines of voltage upto and including 11,000 Volts, if bare - 4.6 metres
 - (ii) for lines of voltage upto and including 11,000 Volts, if insulated 4.0 metres
 - (iii) for lines of voltage exceeding 11,000 Volts but not exceeding 33 kV - 5.2 metres
- (4) For lines of voltage exceeding 33 kV the clearance above ground shall not be less than 5.2 metres plus 0.3 metre for every 33,000 Volts or part thereof by which the voltage of the line exceeds 33,000 Volts; Provided that the minimum clearance along or across any street shall not be less than 6.1 metres.
- (5) For High Voltage Direct Current (HVDC) lines, the clearance above ground shall not be less than—

<i>Sl No.</i>	<i>d.c. Voltage (kV)</i>	<i>Ground Clearance (mtrs.)</i>
1.	100 kV	6.1
2.	200 kV	7.3
3.	300 kV	8.5
4.	400 kV	9.4
5.	500 kV	10.6
6.	600 kV	11.8
7.	800 kV	13.9

- (6) Ground clearance shall be as specified in schedule-X.

Regulation 60, Clearance from buildings of lines of voltage and service lines not exceeding 650 Volts

- (1) An overhead line shall not cross over an existing building as far as possible and no building shall be constructed under an existing overhead line.

- (2) Where an overhead line of voltage not exceeding 650 V passes above or adjacent to or terminates on any building, the following minimum clearance from any accessible point, on the basis of maximum sag, shall be observed, namely—
- (i) for any flat roof, open balcony, verandah roof and lean-to-roof—
 - (a) when the line passes above the building a vertical clearance of 2.5 metres from the highest point, and
 - (b) when the line passes adjacent to the building a horizontal clearance of 1.2 metres from the nearest point, and
 - (ii) for pitched roof —
 - (a) when the line passes above the building a vertical clearance of 2.5 metres immediately under the line, and
 - (b) when the line passes adjacent to the building a horizontal clearance of 1.2 metres.
- (3) Any conductor so situated as to have a clearance less than that specified above shall be adequately insulated and shall be attached at suitable intervals to a bare earthed bearer wire having a breaking strength of not less than 350 kg.
- (4) The horizontal clearance shall be measured when the line is at a maximum deflection from the vertical due to wind pressure.
- (5) Vertical and horizontal clearances shall be as specified in schedule-X.

Explanation — For the purpose of this regulation, the expression “building” shall be deemed to include any structure, whether permanent or temporary.

Regulation 61, Clearance from buildings of lines of voltage exceeding 650 V

- (1) An overhead line shall not cross over an existing building as far as possible and no building shall be constructed under an existing overhead line.
- (2) Where an overhead line of voltage exceeding 650 V passes above or adjacent to any building or part of a building it shall have on the basis of maximum sag a vertical clearance above the highest part of the building immediately under such line, of not less than-
 - (i) for lines of voltage exceeding 650 Volts upto and including 33,000 Volts - 3.7 metres
 - (ii) for lines of voltage exceeding 33 kV - 3.7 metres plus 0.30 metre for every additional 33,000 Volts or part thereof.

- (3) The horizontal clearance between the nearest conductor and any part of such building shall, on the basis of maximum deflection due to wind pressure, be not less than-
 - (i) for lines of voltage exceeding 650 V upto and including 11,000 Volts - 1.2 metres
 - (ii) for lines of voltage exceeding 11,000 Volts and up to and including 33,000 V - 2.0 metres
 - (iii) for lines of voltage exceeding exceeding 33 kV - 2.0 metres plus 0.3 metre for every additional 33 kV or part thereof.

Regulation 63, Erection or alteration of buildings, structures, flood banks and elevation of roads

- (1) If at any time subsequent to the erection of an overhead line, whether covered with insulating material or not or underground cable, any person proposes to erect a new building or structure or flood bank or to raise any road level or to carry out any other type of work whether permanent or temporary or to make in or upon any building, or structure or flood bank or road, any permanent or temporary addition or alteration, he and the contractor whom he employs to carry out the erection, addition or alteration, shall, give intimation in writing of his intention to do so, to the supplier or owner and to the Electrical Inspection and shall furnish therewith a scale drawing showing the proposed building, structure, flood bank, road or any addition or alteration and scaffolding thereof required during the construction.
- (2) On receipt of such intimation, the supplier or owner shall examine,—
 - (i) whether the line or underground cable

under reference was laid in accordance with the provisions of these regulations and any other law for the time being in force;

- (ii) whether it is technically feasible;
 - (iii) whether it meets the requirement of Right of Way (ROW);
 - (iv) whether such person was liable to pay the cost of alteration of the overhead line or underground cable and if so, issue a notice within a period of thirty days, to such person together with an estimate of the cost of the expenditure likely to be incurred to so alter the overhead line or underground cable and require him to deposit, within thirty days of the receipt of the notice, with the supplier or owner, the amount of the estimated cost.
- (3) If such person disputes the cost of alteration of the overhead line or underground cable estimated by the supplier or owner or even the responsibility to pay such cost, the dispute may be referred to the Electrical Inspector who shall after hearing both parties decide upon the issue in accordance with sub-regulation (4).
- (4) The Electrical Inspector shall estimate the cost of alteration of overhead line or underground cable on the following basis, namely:
- (i) the cost of material used on the alteration after crediting the depreciated cost of the material which shall be available from the existing line or underground cable;
 - (ii) the wages of labour employed in affecting the alteration;
 - (iii) supervision charges and charges incurred by the supplier or owner in complying with the provisions of section 67 of the Act, in respect of such alterations.
- (5) Any addition or alteration to the building or structure shall be allowed only after the deposit of such estimated cost to the supplier or owner.
- (6) No work upon such building, structure, flood bank, road and addition or alteration thereto shall be commenced or continued until the Electrical Inspector has certified that the provisions of regulations 58, 60, 61 and regulation 76 should not be contravened either during or after the aforesaid construction: Provided that the Electrical Inspector may, if

he is satisfied that the overhead line or underground cable has been so guarded as to secure the protection of persons or property from injury, certify that the work may be executed prior to the alteration of the overhead line or underground cable or in the case of temporary addition or alteration, without alteration of the overhead line or underground cable.

- (7) The supplier or owner shall, on receipt of such deposit, alter the overhead line or underground cable in such a way that it does not contravene the provisions of regulations 58, 60, 61 and regulation 76 either during or after such construction within two months from the date of such deposit or within such longer period as the Electrical Inspector may permit for reasons to be recorded in writing.

Regulation 64, Transporting and storing of material near overhead lines

- (1) No rods, pipes or similar material shall be taken below, or in the vicinity of, any bare overhead conductors or lines if these contravene the provisions of regulations 60 and 61 unless such materials are transported under the direct supervision of a person designated in this behalf by the owner of such overhead conductors or lines.
- (2) No rods, pipes or other similar materials shall be brought within the flash over distance of bare live conductors or lines.
- (3) No material or earth work or agricultural produce shall be dumped or stored, no trees grown below or in the vicinity of, bare overhead conductors, or lines to contravene the provision of regulations 60 and 61.
- (4) No flammable material shall be stored under the electric supply line.
- (5) No fire shall be allowed above underground cables.
- (6) Firing of any material below electric lines shall be prohibited.

Regulation 65, General clearances

- (1) For the purpose of computing the vertical clearance of an overhead line, the maximum sag of any conductor shall be calculated on the basis of the maximum sag in still air and the maximum temperature as specified under regulations 57 and computing any horizontal clearance of an overhead line the maximum

deflection of any conductor shall be calculated on the basis of the wind pressure specified under regulations 57.

- (2) No blasting for any purpose shall be done within 300 metres from the boundary of a substation or from the electric supply lines of voltage exceeding 650 V or tower structure thereof without the written permission of the owner of such substation or electric supply lines or tower structures; and in case of mining lease hold area, without the written permission of the Electrical Inspector of Mines.
- (3) No cutting of soil within ten meters from the tower structure of 132 kV and above voltage level shall be permitted without the written permission of the owner of tower structure.
- (4) No person shall construct brick kiln or other polluting units near the installations or transmission lines of 220 kV and above within a distance of 500 metres.

Regulation 73(3), Safety and protective devices

- 3) The owner of every overhead line of voltage

exceeding 650 V shall make adequate arrangements as per relevant Indian Standards to prevent undesigned persons from ascending any of the supports of such overhead lines which can be easily climbed upon without the help of a ladder or special appliances.

Explanation — For the purpose of this regulation, rails, reinforced cement concrete poles and pre-stressed cement concrete poles without steps, tubular poles, wooden supports without steps, I-sections and channels' shall be deemed as supports which cannot be easily climbed upon.

Regulation 76, Laying of cables

- (1) No underground power cable of voltage exceeding 33 kV shall be laid without a minimum underground depth of 1.2 meters.
- (2) No underground telecommunication cable shall be laid without a minimum separation distance of 0.6 meters to the underground power cable of voltage exceeding 33 kV.

ANNEX C
[Clauses 4.2.1 (26) and 4.2.2.2]

**AREA REQUIRED FOR TRANSFORMER ROOM AND SUBSTATION FOR
DIFFERENT CAPACITIES**

C-1 The requirement for area for transformer room and substation for different capacities of transformers is given below for guidance:

<i>Sl No.</i>	<i>Capacity of Transformer(s)</i>	<i>Total Transformer Room Area, Min</i>	<i>Total Substation Area (Incoming, HV Panels, MV Panels, Transformer Roof but Without Generators), Min</i>	<i>Suggested Minimum Face Width</i>
(1)	kVA (2)	m ² (3)	m ² (4)	m (5)
i)	1 × 160	14.0	90	9.0
ii)	2 × 160	28.0	118	13.5
iii)	1 × 250	15.0	91	9.0
iv)	2 × 250	30.0	121	13.5
v)	1 × 400	16.5	93	9.0
vi)	2 × 400	33.0	125	13.5
vii)	3 × 400	49.5	167	18.0
viii)	2 × 500	36.0	130	14.5
ix)	3 × 500	54.0	172	19.0
x)	2 × 630	36.0	132	14.5
xi)	3 × 630	54.0	176	19.0
xii)	2 × 800	39.0	135	14.5
xiii)	3 × 800	58.0	181	14.0
xiv)	2 × 1 000	39.0	149	14.5
xv)	3 × 1 000	58.0	197	19.0

NOTES

1 The areas given in respect of the different categories of rooms hold good, if they are provided with independent access doors in accordance with local regulations.

2 The minimum height of substation room/HV switch room/MV switch room shall be arrived at considering 1 200 mm clearance requirement from top of the equipment to the below of the soffit of the beam. In case cable entry/exit is from above the equipment (transformer, HV switchgear, MV switchgear), height of substation room/HV switch room/MV switch room shall also take into account requirement of space for turning radius of cable above the equipment height

3 Additional space will be required in cases where the load requirement calls for redundancy for enhanced reliability through addition of switchgear, such as, bus couplers, etc.

4 For transformers of other capacity, it may lead to some minor changes in dimensioning.

ANNEX D
(Clause 4.3.2)

ADDITIONAL AREA REQUIRED FOR GENERATOR IN ELECTRIC SUBSTATION

D-1 The requirement of additional area for generator in electric substation for different capacities of generators is given in the table below for guidance.

NOTES

1 The space requirements vary for specific installations due to factors such as derating due to site conditions (temperature, altitude etc); type of cooling (radiator, heat exchanger, cooling tower, etc); type of ventilation; noise suppression system and special characteristics of loads, if any.

2 If the generator is located away from the substation, then additional switchgear will be required, area requirement for which can be estimated from the norms given in Annex C.

3 The area requirement suggested below covers the space requirement for day-tank and not the space for the bulk fuel storage.

<i>Sl No.</i>	<i>Capacity kVA</i>	<i>Area m²</i>	<i>Clear Height below the Soffit of the Beam m</i>
(1)	(2)	(3)	(4)
i)	25	56	3.6
ii)	48	56	3.6
iii)	100	65	3.6
iv)	150	72	3.6
v)	248	100	4.2
vi)	350	100	4.2
vii)	480	100	4.2
viii)	600	110	4.6
ix)	800	120	4.6
x)	1 010	120	6.5
xi)	1 250	120	6.5
xii)	1 600	150	6.5
xiii)	2 000	150	6.5

NOTE — The area and height required for generating set room given in the above table are for general guidance only and may be finally fixed according to actual requirements.

ANNEX E

(Clause 9.4)

CHECKLIST FOR INSPECTION, HANDING OVER AND COMMISSIONING OF VARIOUS EQUIPMENT OF SUBSTATION

E-1 Typical format for checklist for inspection, handing over and commissioning of HV cables is given below.

NOTE — Format given below covers a basic minimum check list; it should be augmented for specific and special cases. The checklist has to be repeated for each HV cable.

HV CABLE INSPECTION, HANDING OVER AND COMMISSIONING DETAILS

A) DETAILS OF WORK

- 1) Scope of works :
- 2) Handed over by :
- 3) Taken over by :
- 4) Date of commissioning :
- 5) Date of handing over :
- 6) Details of enclosures :

<i>Sl No.</i>	<i>Description</i>	<i>Applicable</i>	<i>Not Applicable</i>
(1)	(2)	(3)	(4)
i)	Quality check list		
ii)	Site test report		

<i>Sl No.</i>	<i>Description</i>	<i>Applicable</i>	<i>Not Applicable</i>
(1)	(2)	(3)	(4)
iii)	As built GA drawing/layout		
iv)	Manufacturer's test certificates		
v)	Operation and maintenance manual		

Handed over by Taken over by
 Authorized signatory Authorized signatory

B) QUALITY CHECK LIST

Item: Installation of HV Cables

Make:

<i>Sl No.</i>	<i>Tests Parameters</i>	<i>Bench Mark</i>	<i>Actual Observations</i>	<i>Remark</i>
(1)	(2)	(3)	(4)	(5)
i)	Cable size			
ii)	Voltage grade			
iii)	Type of material			
iv)	Check for routing			
v)	Meggering using 2.5 kV insulation tester			
	R-Y			
	Y-B			
	B-R			
	R-E			
	Y-E			
	B-E			
vi)	Minimum width of trench			
vii)	Minimum depth of trench			
viii)	Hume pipes used			
ix)	Hume joints with collar properly aligned and packed with 75 mm of cement concrete			
x)	Cable laying with suitable rollers			
xi)	Bending radius			
xii)	Cable tagging			
xiii)	Hi-Pot test (18 kV)			
xiv)	Sealing of cable ends, if not being terminated immediately			
xv)	Trench closing			

C) HI-POT TEST REPORT

- 1) Date of testing:
- 2) Equipment details:
 - Cable details*
 - Location :
 - Panel No. :
 - Size :

3) Insulation Resistance Test (Value in MΩ, using 5 kV Megger):

Reference	Measured Values MΩ	
	Before	After
R-E		
Y-E		
B-E		
R-Y		
Y-B		
B-R		

4) Winding Resistance Test:

Applied Voltage kV	Measured Current mA
R = Y + B + E	
Y = B + R + E	
B = R + Y + E	

5) Remarks

E-2 Typical format for checklist for handing over and commissioning of HV panels is given below.

NOTE — Format given below covers a basic minimum check list; it should be augmented for specific and special cases. The checklist has to be repeated for each HV panel.

HV PANEL INSPECTION, HANDING OVER AND COMMISSIONING DETAILS

Project:

Owner:

Package:

Contractor:

A) HANDING OVER DETAILS

- 1) Scope of works :
- 2) Panel name and number :
- 3) Location :
- 4) Handed over by :
- 5) Taken over by :
- 6) Date of commissioning :
- 7) Date of handing over :
- 8) Details of enclosures :

Sl No.	Description	Applicable	Not Applicable
(1)	(2)	(3)	(4)
i)	Quality check list		
ii)	Site test report		
iii)	As built GA drawing/layout		

<i>Sl No.</i>	<i>Description</i>	<i>Applicable</i>	<i>Not Applicable</i>
(1)	(2)	(3)	(4)
iv)	Manufacturer's test certificates		
v)	Operation and maintenance manual		

Handed over by
Authorized signatory

Taken over by
Authorized signatory

B) QUALITY CHECK LIST

Item: HV panel

Make:

Relevant Indian Standard:

As-built Drawing No:

<i>Sl No.</i>	<i>Test Parameters</i>	<i>Bench Mark</i>	<i>Actual Observations</i>
(1)	(2)	(3)	(4)
	<i>Physical Checks for:</i>		
	<i>Circuit Breaker</i>		
i)	Dimension enclosure		
ii)	Gauge		
iii)	Paint		
iv)	Degree of protection		
v)	Front doors		
vi)	Back cover		
vii)	Extension type enclosure		
viii)	Type of circuit breaker		
ix)	Number of circuit breakers		
x)	Type of surge arresting device included in the circuit breakers		
xi)	Earthing terminal		
xii)	Front plate with view glass		
xiii)	Space for mounting of current transformers		
xiv)	Space for mounting of potential transformers		
xv)	Cable entry		
xvi)	Interlocking with isolator		
xvii)	Earthing switch for cable in cable chamber		
xviii)	Earthing switch interlock with circuit breaker only it can be operated in 'OFF' condition		
xv)	Low voltage plug and socket		
xvi)	Vents for breaker/busbar/cable chambers		
xvii)	Insulation level		
xviii)	Toggle switch		
xix)	Ammeter selector switch		
xx)	Voltmeter selector switch		
xxi)	Trip/Neutral/Close		
xxii)	Local/remote selector switch		
xxiii)	LED lamps		
xxiv)	Mechanical operation		

<i>Sl No.</i>	<i>Test Parameters</i>	<i>Bench Mark</i>	<i>Actual Observations</i>
(1)	(2)	(3)	(4)
xxv)	Remote operation		
xxvi)	Local operation		
xxvii)	Interlocking with isolator		
	<i>Meters</i>		
xxviii)	Voltmeter		
xxix)	Ammeter		
xxx)	Tri vector meter		
xxxi)	Power factor meter		
xxxii)	Frequency meter		
	<i>Specification Checks for</i>		
xxxiii)	Rated current		
xxxiv)	Rated voltage		
xxxv)	Rated short circuit breaking capacity		
xxxvi)	Contact resistance		
xxxvii)	Control wiring		
xxxviii)	All control circuits		
	Alarm and trip for OTI/WTI/Buchholz/ PRV		
xxxix)	SF6 pressure alarm and trip operation test		

C) COMMISSIONING REPORT

Customer:

Project:

Contractor:

Panel Name:

Location:

Breaker Details:

INSULATION TEST (MΩ):

R-Y	Y-B	B-R	R-E	Y-E	B-E	R-N	Y-N	B-N

RELAY SETTINGS:

Over Current, Earth Fault and Undervoltage Relay	
CT ratio:	
Earth fault >Settings:	
I_o > Settings:	
Under voltage relay:	

GENERAL CHECKS:

Breaker 'ON'/'OFF'	
Meters reading	
Indicating lamps	
Control supply	

E-3 Typical format for checklist for handing over and commissioning of transformers is given below.

NOTE — Format given below covers a basic minimum check list; it should be augmented for specific and special cases. The checklist has to be repeated for each transformer.

TRANSFORMER INSPECTION, HANDING OVER AND COMMISSIONING DETAILS

Project:

Owner:

Package:

Contractor:

A) HANDING OVER DETAILS

- 1) Scope of works :
- 2) Transformer No. :
- 3) Location :
- 4) Handed over by :
- 5) Taken over by :
- 6) Date of commissioning :
- 7) Date of handing over :
- 8) Details of enclosures :

<i>Sl No.</i> (1)	<i>Description</i> (2)	<i>Applicable</i> (3)	<i>Not Applicable</i> (4)
i)	Quality check list		
ii)	Site test report		
iii)	As built GA drawing/layout		
iv)	Manufacturer's test certificates		
v)	Operation and maintenance manual		

Handed over by
Authorized signatory

Taken over by
Authorized signatory

B) QUALITY CHECK LIST

Item: Transformer

Make:

Relevant Indian Standard:

As-built Drawing No:

<i>Sl No.</i> (1)	<i>Test Parameters</i> (2)	<i>Bench Mark</i> (3)	<i>Actual Observation</i> (4)
----------------------	-------------------------------	--------------------------	----------------------------------

Physical Checks for:

- i) Transformer Sl No.
- ii) Dimension of enclosure
- iii) Enclosure – Degree of protection
- iv) Gauge
- v) Paint

<i>Sl No.</i>	<i>Test Parameters</i>	<i>Bench Mark</i>	<i>Actual Observation</i>
(1)	(2)	(3)	(4)
vi)	Provision for lifts and jacking		
vii)	Wheels		
viii)	Locking facility for wheel		
ix)	Enclosure door (if applicable)		
x)	Enclosure door interlock wiring		
xi)	Removable case for access of taps		
xii)	Earthing terminal		
xiii)	Disconnecting type chamber for cable termination		
xiv)	LT side flanges (Bus ducts/Cables/ Overhead)		
xv)	Oil temperature indicator (relay unit)		
xvi)	Winding temperature indicator (relay unit)		
xvii)	Marshalling box winding and door switch		
xviii)	Thermistors for alarm and trip		
xix)	Separate neutral earthing chamber		
xx)	Rating and diagram plate		
xxi)	Tap changing options name plate		
xxii)	Oil level in conservator tank		
xxiii)	Oil level in breather cup		
xxiv)	Operation of PRV		
xxv)	Oil leakage (if applicable)		
xxvi)	Clearances around transformer		
xxvii)	Body earthing resistance		
xxviii)	Neutral earthing resistance		
	<i>Specification checks for:</i>		
xxix)	Rating of transformer		
xxx)	Type		
xxxi)	Winding conductor		
xxxii)	Primary voltage		
xxxiii)	HV winding connections		
xxxiv)	Secondary voltage		
xxxv)	LV side connections		
xxxvi)	Vector symbol		
xxxvii)	System of supply		
xxxviii)	Impedance percentage		
xxxix)	Oil temperature rise		
xl)	Winding temperature rise		
xli)	Tap changing		
xlii)	Tapping range		
xliii)	Insulation type		
xliv)	Type of cooling		
xlv)	Vector group test		
xlvi)	Polarity test		
xlvii)	Magnetizing test		
xlviii)	Tan delta test (as per capacity)		

<i>Sl No.</i>	<i>Test Parameters</i>	<i>Bench Mark</i>	<i>Actual Observation</i>
(1)	(2)	(3)	(4)
xlix)	Breakdown voltage test: <i>Oil sample – I (Top)</i> <i>Oil sample – II (Bottom)</i>		

C) COMMISSIONING REPORT

Customer:

Project:

Contractor:

Transformer Number:

Location:

Rating:

INSULATION TEST (MΩ):

R-Y	Y-B	B-R	R-E	Y-E	B-E	R-N	Y-N	B-N

RELAY SETTINGS:

Transformer Protection Relay (WTI Scanner): Winding temperature alarm set Winding temperature trip set (OTI Scanner): Oil temperature alarm set Oil temperature trip set	
Buchholz Relay	

GENERAL CHECKS:

Breaker 'ON'/'OFF'	
Meters reading	
Indicating lamps	
Control supply	

E-4 Typical format for checklist for handing over and commissioning of MV/LV panel is given below.

NOTE — Format given below covers a basic minimum check list; it should be augmented for specific and special cases. The checklist has to be repeated for each MV/LV panel.

MV/LV PANEL INSPECTION, HANDING OVER AND COMMISSIONING DETAILS**Project:****Owner:****Package:****Contractor:****A) HANDING OVER DETAILS**

- 1) Scope of works :
- 2) Panel name :
- 3) Location :
- 4) Handed over by :
- 5) Taken over by :
- 6) Date of commissioning :
- 7) Date of handing over :
- 8) Details of enclosures :

<i>Sl No.</i>	<i>Description</i>	<i>Applicable</i>	<i>Not Applicable</i>
(1)	(2)	(3)	(4)
i)	Quality check list		
ii)	Site test report		
iii)	As built GA drawing		
iv)	Manufacturer's test certificates		
v)	Operation and maintenance manual		

Handed over by
Authorized signatory

Taken over by
Authorized signatory

B) QUALITY CHECK LIST**Item:** MV/LV Panel**Make:****Relevant Indian Standard:****As-built Drawing No:**

<i>Sl No.</i>	<i>Test Parameters</i>	<i>Bench Mark</i>	<i>Actual Observation</i>
(1)	(2)	(3)	(4)
	<i>Physical Checks for:</i>		
i)	Dimension enclosure		
ii)	Paint		
iii)	Degree of protection		

<i>Sl No.</i>	<i>Test Parameters</i>	<i>Bench Mark</i>	<i>Actual Observation</i>
(1)	(2)	(3)	(4)
iv)	Front doors		
v)	Back cover		
vi)	Earthing terminal		
vii)	Front plate with view glass		
viii)	Cable entry		
ix)	Indication lamps		
x)	Check for any damages		
xi)	Check for rubber beading for the panel sections		
xii)	Coupling of panel		
xiii)	Coupling of busbars		
xiv)	Coupling of earth bus		
xv)	Number of shipping sections		
xvi)	Fish plate tightening		
xvii)	Any damages in busbar supports		
xviii)	Make of MCCB		
	<i>Specification Checks For</i>		
xix)	Rated current		
xx)	Rated voltage		
xxi)	Rated short circuit capacity		
	Circuit Breaker:		
xxii)	Current rating		
xxiii)	Interlocks with other CB/relay		
xxiv)	Compartment		
xxv)	End terminals segregation		
	Bus bar:		
xxvi)	Earth bus bar		
xxvii)	Main bus bar		
xxviii)	Link bus bar		
xxix)	Bus bar sleeve		
	3 Phase – Potential transformer:		
xxx)	Make		
xxxi)	Ratio		
xxxii)	Class		
xxxiii)	Serial Nos.		
	Current transformer:		
xxxiv)	Make		
xxxv)	Ratio		
xxxvi)	Class		
xxxvii)	Serial No's		
	Multi digital meter:		
xxxviii)	Make		
xxxix)	Input voltage		
xl)	Input current		

<i>Sl No.</i>	<i>Test Parameters</i>	<i>Bench Mark</i>	<i>Actual Observation</i>
(1)	(2)	(3)	(4)
	Wiring:		
xli)	For potential transformer		
xlii)	For current transformer		
xliii)	Incomer		
xliv)	Outgoing		

C) COMMISSIONING REPORT

Customer:

Project:

Contractor:

Panel Name:

Location:

Breaker Details:

INSULATION TEST (M Ω):

R-Y	Y-B	B-R	R-E	Y-E	B-E	R-N	Y-N	B-N

RELAY SETTINGS:

--

GENERAL CHECKS:

Breaker 'ON'/'OFF'	
Meters reading	
Indicating lamps	
Control supply	

ANNEX F

(Clause 9.4)

CHECKLIST FOR INSPECTION, HANDING OVER AND COMMISSIONING OF EARTHING PITS

F-1 Typical format for checklist for inspection, handing over and commissioning of earthing pits is given below:

Project:

Owner:

Package:

Contractor:

A) HANDING OVER DETAILS

- 1) Scope of works :
- 2) Handed over by :
- 3) Taken over by :
- 4) Date of commissioning :
- 5) Date of handing over :
- 6) Details of enclosures :

<i>Sl No.</i>	<i>Description</i>	<i>Applicable</i>	<i>Not Applicable</i>
(1)	(2)	(3)	(4)
i)	Quality check list		
ii)	Site test report		
iii)	As built GA drawing/layout		

Handed over by
Authorized signatory

Taken over by
Authorized signatory

B) QUALITY CHECK LIST**Item:** Installation of earthing pit**As-built Drawing No:**

<i>Sl No.</i>	<i>Test Parameters</i>	<i>Bench Mark</i>	<i>Actual Observations</i>	<i>Remarks</i>
(1)	(2)	(3)	(4)	(5)
1)	Material (Cu/GI/Copper bonded) and size			
2)	Depth of the pit			
3)	Check for length of pipe/rod and size of the plate and strip			
4)	For copper earthing, brazing done on both surfaces before jointing; and on one side in case of exothermic welding			
5)	Packing of pit by sand, salt and charcoal/earth enhancing material			
6)	Check connection for tightness			
7)	Check for distance between earth pits			
8)	Interconnection of earth strips			
9)	Earth enhancing material used in earth pits			

C) TEST REPORT: EARTH PIT**Date of testing** :**Equipment details :***Earth pit*

- 1) Location :
- 2) Serial No. :

- 3) Earth pit No. :
 4) Type of earthing :
 5) Description :
 6) Size of earth conductor :

Earth Pit Test: Values (Ω)

Ref	Measured Values Ω
Pit	
Width grid	

ANNEX G

(Clause 9.3.2.6)

FORM OF COMPLETION CERTIFICATE

I/ We certify that the installation detailed below has been installed by me/us and tested and that to the best of my/our knowledge and belief, it complies with *Central Electricity Authority (Measures Relating to Safety and Electricity Supply) Regulations, 2010* as amended up-to-date.

Electrical Installation at

A) INSTALLATION DATA

Voltage and system of supply

a) Particulars of Works:

1) Internal electrical installation

<i>Sl No.</i>	<i>Description</i>	<i>No.</i>	<i>Total Load</i>	<i>Type of System of Wiring</i>
i)	Light point			
ii)	Fan point			
iii)	Plug point			
	3-pin 6 A			
	3-pin 16 A			
	5-pin 6 A			
	6-pin 16 A			

2) Others

<i>Sl No.</i>	<i>Description</i>	<i>HP/kW</i>	<i>Type of Starting</i>
i)	Motors		
	1)		
	2)		
	3)		
ii)	Other plants		
	1)		
	2)		
	3)		

3) If the work involves installations of overhead line and/or underground cable

i)	1) Type and description of over headline	
	2) Total length and No. of spans	
	3) No. of street lights and its description	
ii)	1) Total length of underground cable and its size	
	2) No. of joints:	
	End joint:	
	Tee joint:	
	Straight through joint:	

b) Earthing:

i)	Description of earthing electrode	
ii)	No. of earth electrodes	
iii)	Size of main earth lead	
iv)	Earth electrode resistance	

The date on which the measurements for item (iv) was taken has to be recorded.

NOTE — The above data should be supported by an appropriate drawing and tables indicating the reference points at which the measurements were taken at the construction/installation stage.

B) PRE-COMMISSIONING TEST DATAa) *Test Results:*

- 1) Appropriate drawings showing the points at which the measurements were taken should accompany this report.
- 2) Environmental notes pertaining to the day on which the tests are conducted:
 - i) Temperature:
 - ii) Date and time:
 - iii) Previous day/days history from the aspect of rain (as it would affect the test results):
- 3) List of test instruments used:
(Please record the calibration certificate date, calibration authority and the validity date of each instrument listed.)
 - i)
 - ii)
- 4) Results:

i)	Insulation resistance	
a)	Insulation resistance of the whole system of conductors to earth Megaohm
b)	Insulation resistance between the phase conductor and neutral:	
	Between phase R and neutral Megaohm
	Between phase Y and neutral Megaohm
	Between phase B and neutral Megaohm
c)	Insulation resistance between the phase conductors in case of polyphase supply	
	Between phase R and phase Y Megaohm
	Between phase Y and phase B Megaohm
	Between phase B and phase R Megaohm
d)	Insulation resistance between neutral conductor and earth in case of systems with neutral solidly earthed at the source Megaohm

- ii) Polarity test:
Polarity of non-linked single pole branch switches:
- iii) Earth continuity test:
Maximum resistance between any point in the earth continuity conductor including metal conduits and main earthing leadOhm.
- iv) Earth electrode resistance:
 - a) Resistance of each earth electrode:
 - 1) Ohm
 - 2) Ohm
 - 3) Ohm
 - 4) Ohm
 - b) Resistance of each earth grid:
 - 1) Ohm
 - 2) Ohm
 - 3) Ohm
 - 4) Ohm
- v) Lightning protective system:

a)	Designed lightning protection level (LPL)
b)	Total roof area (L X W) m ²
c)	Air-termination mesh size (L X W) m x m
d)	Number of vertical rods/terminal (Down-conductors)
e)	Distance between down-conductors m
f)	Impulse current rating of SPD, if provided kA
g)	Voltage protection level of incoming SPD kV
h)	Resistance of down-conductor for reinforced concrete structure/PEB structures, if natural components are used as per National Building Code of India (Part 8/Section 2) 'Building Services, Electrical and Allied Installations' ohm
j)	Resistance of the whole of lightning protective system to earth before any bonding is effected with earth electrode and metal in/on the structure ohm

Signature of Supervisor
Name and Address

Signature of Contractor
Name and Address

Persons witnessing the test:

Name	Designation/Address	Signature	Remarks
-----	-----	-----	-----

LIST OF STANDARDS

The following list records those standards which are acceptable as 'good practice' and 'accepted standards' in the fulfillment of the requirements of the Code. The latest version of a standard shall be adopted at the time of enforcement of the Code. The standards listed may be used by the Authority for conformance with the requirements of the referred clauses in the Code.

In the following list, the number appearing in the first column within parenthesis indicates the number of the reference in this Section.

<i>Sl No.</i>	<i>IS No.</i>	<i>Title</i>
(1)	IS 8270 (Part 1) : 1976	Guide for preparation of diagrams, charts and tables for electrotechnology: Part 1 Definitions and classification
	IS 1885	Electrotechnical vocabulary
	(Part 16/Sec 3) : 1967	Lighting, Section 3 Lamps and auxiliary apparatus
	(Part 17) : 1979	Switchgear and controlgear (<i>first revision</i>)
	(Part 32) : 1993	Electrical cables (<i>first revision</i>)
	(Part 78) : 1993	Generation, transmission and distribution of electricity — General
	IS 12032	Graphical symbols for diagrams in the field of electrotechnology
	(Part 6) : 1987	Protection and conversion of electrical energy
	(Part 7) : 1987	Switchgear, controlgear and protective devices
(2)	IS 16246 : 2015	Specification of elastomer insulated cables with limited circuit integrity when affected by fire
(3)	IS 694 : 2010	Polyvinyl chloride insulated unsheathed and sheathed cables/cords with rigid and flexible conductor for rated voltages up to and including 450/750 V (<i>fourth revision</i>)
(4)	IS/IEC 62271-202 : 2014	High-voltage switchgear and controlgear—Part 202: High-voltage/low-voltage prefabricated substation
(5)	IS/IEC 60947-1 : 2007	Low-voltage switchgear and controlgear — Part 1: General rules (<i>first revision</i>)
	IS/IEC 60947-2 : 2003	Low-voltage switchgear and controlgear — Part 2 : Circuit breakers
	IS/IEC 60947-3 : 1999	Low-voltage switchgear and controlgear — Part 3: Switches, disconnectors, switch-disconnectors and fuse combination units
	IS/IEC 60947-4-1 : 2000	Low-voltage switchgear and controlgear — Part 4 : Contractors and motor-starters — Section 1 : Electromechanical contactors and motors-starters
	IS/IEC 60947-4-2 : 1999	Low-voltage switchgear and controlgear : Part 4 — Contractors and Motor-Starters, Section 2 A.C. Semiconductor Motor Controllers and Starters
	IS/IEC 60947-4-3 : 1999	Low-voltage switchgear and controlgear — Part 4: A.C. semiconductor controllers and contactors for non-motor loads
	IS/IEC 60947-5-1 : 2003	Low-voltage switchgear and controlgear — Part 5 : Control circuit devices and switching elements, Section 1 : Electromechanical control circuit devices
	IS/IEC 60947-5-2 : 2007	Low-voltage switchgear and control gear — Part 5: Control circuit devices and switching elements, Section 2 Proximity switches
(6)	IS/IEC 60529 : 2001	Degrees of protection provided by enclosures (IP code)

<i>Sl No.</i>	<i>IS No.</i>	<i>Title</i>	<i>Sl No.</i>	<i>IS No.</i>	<i>Title</i>
(7)	IS 7752 (Part 1) : 1975	Guide for improvement of power factor in consumer installation: Part 1 Low and medium supply voltages		IS/IEC 62271-104 : 2009	High-voltage switchgear and controlgear — Part 104: Alternating current for rated voltages of 52 kV and above
(8)	IS 5216 (Part 1) : 1982 (Part 2) : 1982	Recommendations on safety procedures and practices in electrical work General (<i>first revision</i>) Life saving techniques (<i>first revision</i>)		IS/IEC 62271-105 : 2002 IS/IEC 62271-111 : 2012	High-voltage switchgear and controlgear — Part 104: Alternating current switch-fuse combinations High-voltage switchgear and controlgear — Part 104: Automatic circuit reclosers and fault interrupters for alternating current systems up to 38 kV
(9)	IS 10028 (Part 2) : 1981	Code of practice for selection, installation and maintenance of transformers: Part 2 Installation		IS/IEC 62271-200 : 2003	High-voltage switchgear and controlgear — Part 104: a.c. metal-enclosed switchgear and controlgear for rated voltages above 1 kV and up to and including 52 kV
(10)	IS 10118 (Part 3) : 1982	Code of practice for selection, installation and maintenance of switchgear and controlgear: Part 3 Installation		IS/IEC 62271-201 : 2006	High-voltage switchgear and controlgear — Part 104: a.c. insulation-enclosed switchgear and control-gear for rated voltages above 1 kV and up to and including 52 kV
(11)	IS 732 : 1989	Code of practice for electrical wiring installations (<i>third revision</i>)		IS/IEC 62271-203 : 2003	High-voltage switchgear and controlgear — Part 203: Gas-insulated metal-enclosed switchgear for rated voltages above 52 kV
(12)	IS 10118 (Part 2) : 1982	Code of practice for selection, installation and maintenance of switchgear and controlgear: Part 2 Selection	(15)	IS 1255 : 1983	Code of practice for installation and maintenance of power cables (up to and including 33 kV rating) (<i>second revision</i>)
(13)	IS 1646 : 2015	Code of practice for fire safety of buildings (general): Electrical installations (<i>third revision</i>)	(16)	IS 8084 : 1976	Specification for interconnecting bus-bars for a.c. voltage above 1 kV up to and including 36 kV
(14)	IS/IEC 60470 : 2000	High-voltage switchgear alternating current contactors and contactor-based motor starters	(17)	IS 1180 (Part 1) : 2014	Specification for outdoor type oil immersed distribution transformers up to and including 2 500 kVA, 33kV: Part 1 Mineral oil immersed (<i>fourth revision</i>)
	IS/IEC 62271-1 : 2007	High-voltage switchgear and controlgear — Part 1: Common specifications			
	IS/IEC 62271-100 : 2008	High-voltage switchgear and controlgear — Part 100: Alternating-current circuit-breakers			
	IS/IEC 62271-103 : 2011	High-voltage switchgear and controlgear — Part 103: Switches for rated voltages above 1 kV up to and including 52 kV			

<i>Sl No.</i>	<i>IS No.</i>	<i>Title</i>	<i>Sl No.</i>	<i>IS No.</i>	<i>Title</i>
	IS 2026	Power transformers		IS/IEC 60947-4-2 : 2011	Low-voltage switchgear and controlgear — Part 4: Contractors and motor-starters, Section 2 a.c. semiconductor motor controllers and starters (<i>first revision</i>)
	(Part 1) : 2011	General (<i>second revision</i>)			
	(Part 2) : 2010	Temperature-rise (<i>first revision</i>)		IS/IEC 60947-4-3 : 2011	Low-voltage switchgear and controlgear — Part 4: Contractors and motor-starters, Section 3 a.c. semiconductor motor controllers and contactors for non-motor loads (<i>first revision</i>)
	(Part 3) : 2009	Insulation levels, dielectric tests and external clearances in air (<i>third revision</i>)			
	IEC 60076-3 : 2000				
	(Part 4) : 1977	Terminal marking, tapplings and connections (<i>first revision</i>)			
	(Part 5) : 2011	Ability to withstand short circuit (<i>first revision</i>)		IS/IEC 60947-5-1 : 2003	Low-voltage switchgear and controlgear — Part 5: Control circuit devices and switching elements, Section 1 Electromechanical control circuit devices
	(Part 7) : 2009	Loading guide for oil-immersed power transformers			
	IEC 60076-7 : 2005			IS/IEC 60947-5-2 : 2007	Low-voltage switchgear and control gear — Part 5: Control circuit devices and switching elements, Section 2 Proximity switches
	(Part 8) : 2009	Applications guide			
	IEC 60076-8 : 1997				
	(Part 10) : 2009	Determination of sound levels			
	IEC 60076-10 : 2001				
	IS 11171 : 1985	Dry-type power transformers		IS/IEC 61439 (Part 0) : 2014	Low-voltage switchgear and controlgear assemblies — Part 0 Guidance to specifying assemblies
(18)	IS 8623 (Part 1) : 1993	Low-voltage switchgear and controlgear assemblies: Part 1 Requirements for type-tested and partially type-tested assemblies	(19)	IS 11353 : 1985	Guide for uniform system of marking and identification of conductors and apparatus terminals
	IS/IEC 60947-1 : 2007	Low-voltage switchgear and controlgear — Part 1: General rules (<i>first revision</i>)	(20)	IS 8623(Part 2) : 1993	Specification for low-voltage switchgear and controlgear assemblies: Part 2 Particular requirements for busbar trunking systems (busways) (<i>first revision</i>)
	IS/IEC 60947-2 : 2003	Low-voltage switchgear and controlgear — Part 2: Circuit breakers	(21)	IS 13010 : 2002	Specification for a.c. watt-hour meters, class 0.5, 1 and 2 (<i>first revision</i>)
	IS/IEC 60947-3 : 1999	Low-voltage switchgear and controlgear — Part 3: Switches, disconnectors, switch-disconnectors and fuse combination units		IS 13779 : 1999	Specification for a.c. static watt-hour meters, class 1 and 2 (<i>first revision</i>)
	IS/IEC 60947-4-1 : 2000	Low-voltage switchgear and controlgear — Part 4: Contractors and motor-starters, Section 1 Electromechanical contactors and motors-starters		IS 8530 : 1977	Specification for maximum demand indicators, class 1

<i>Sl No.</i>	<i>IS No.</i>	<i>Title</i>	<i>Sl No.</i>	<i>IS No.</i>	<i>Title</i>
	IS 14372 : 1996	Specification for volt-ampere hour meters for full power factor range	(26)	IS 2206(Part 1) : 1984	Flameproof electric lighting fittings: Part 1 Well-glass and bulkhead types (<i>first revision</i>)
	IS 14415 : 1997	Specification for volt-ampere hour meters for restricted power factor range		IS 3528 : 1966	Specification for waterproof electric lighting fittings
	IS 14697 : 1999	Specification for a.c. static transformer operated watt-hour and var-hour meters, class 0.2 S and 0.5 S		IS 3553 : 1966	Specification for watertight electric lighting fittings
	IS 15844 : 2010	Specification for alternating current direct connected static prepayment meters for active energy (Class 1 and 2)		IS 5077 : 1969	Specification for decorative lighting outfits
	IS 16444 : 2015	Specification for a.c. static direct connected watt-hour smart meter class 1 and 2		IS 10322 (Part 5/ Sec 5) : 2013	Luminaires: Part 5 Particular requirements, Section 5 Flood lights (<i>first revision</i>)
(22)	IS 15707 : 2006	Code of practice for testing, evaluation, installation and maintenance of a.c. electricity meters	(27)	IS 12640 (Part 1) : 2016	Residual current operated circuit-breakers without integral overcurrent protection for household and similar uses (RCCBs) — Part 1: General rules (<i>second revision</i>)
(23)	IS/IEC 60079-1 : 2007	Explosive atmospheres — Part 1 : Equipment protection by flameproof enclosures “d”		IEC 61008-1 : 2012	Residual current operated circuit-breakers with integral overcurrent protection for household and similar uses (RCBOs) — Part 2: General rules (<i>second revision</i>)
(24)	IS 5578 : 1984	Guide for marking of insulated conductors (<i>first revision</i>)		IS 12640 (Part 2) : 2016	Residual current operated circuit-breakers with integral overcurrent protection for household and similar uses (RCBOs) — Part 2: General rules (<i>second revision</i>)
	IS 11353 : 1985	Guide for uniform system of marking and identification of conductors and apparatus terminals		IEC 61009-1 : 2012	Residual current operated protective devices (RCDs) for household and similar use — Electromagnetic compatibility
(25)	IS/IEC 60309-1 : 2002	Plugs, socket-outlets and couplers for industrial purposes — Part 1: General requirements (<i>first revision</i>)		IS 14614 : 1998	Electrical accessories — Circuit breakers for over current protection for household and similar installations — Part 1: Circuit breakers for a.c. operation
	IS/IEC 60309-2 : 2002	Plugs, socket-outlets and couplers for industrial purposes — Part 2: Dimensional interchangeability requirements for pin and contact-tube accessories (<i>first revision</i>)		IEC 1543 : 1995	Low-voltage switchgear and controlgear — Part 1: General rules (<i>first revision</i>)
				IS/IEC 60898-1 : 2002	Low-voltage switchgear and controlgear — Part 2: Circuit breakers
				IS/IEC 60947-1 : 2007	
				IS/IEC 60947-2 : 2003	

<i>Sl No.</i>	<i>IS No.</i>	<i>Title</i>	<i>Sl No.</i>	<i>IS No.</i>	<i>Title</i>
	IS/IEC 60947-3 : 1999	Low-voltage switchgear and controlgear — Part 3: Switches, disconnectors, switch-disconnectors and fuse combination units		(Part 6) : 2016	Crosslinked polyethylene insulated PVC sheathed cables
	IS/IEC 60947-4-1 : 2000	Low-voltage switchgear and controlgear — Part 4: Contractors and motor-starters, Section 1 Electro-mechanical contactors and motors-starters	(29)	IS 2086 : 1993	Specification for carriers and bases used in rewirable type electric fuses for voltages up to 650 V (<i>third revision</i>)
	IS/IEC 60947-4-2 : 2011	Low-voltage switchgear and controlgear — Part 4: Contractors and motor-starters, Section 2 a.c. semiconductor motor controllers and starters (<i>first revision</i>)		IS 13703(Part 1) : 1993	Specification for low-voltage fuses for voltages not exceeding 1 000 V a.c. or 1 500 V d.c.: Part 1 General requirements
	IS/IEC 60947-4-3 : 2011	Low-voltage switchgear and controlgear — Part 4: Contractors and motor-starters, Section 3 a.c. semiconductor motor controllers and contactors for non-motor loads (<i>first revision</i>)	(30)	IS 2672 : 1966	Code of practice for library lighting
	IS/IEC 60947-5-1 : 2003	Low-voltage switchgear and controlgear — Part 5: Control circuit devices and switching elements, Section 1 Electro-mechanical control circuit devices		IS 4347 : 1967	Code of practice for hospital lighting
	IS/IEC 60947-5-2 : 2007	Low-voltage switchgear and control gear — Part 5: Control circuit devices and switching elements, Section 2 Proximity switches		IS 6665 : 1972	Code of practice for industrial lighting
(28)	IS 3961	Recommended current ratings for cables		IS 8030 : 1976	Specification for luminaires for hospitals
	(Part 1) : 1967	Paper insulated lead sheathed cables	(31)	IS 4648 : 1968	Guide for electrical layout in residential buildings
	(Part 2) : 1967	PVC insulated and PVC sheathed heavy duty cables	(32)	IS 900 : 1992	Code of practice for installation and maintenance of induction motors (<i>second revision</i>)
	(Part 3) : 1968	Rubber insulated cables	(33)	IS 3480 : 1966	Specification for flexible steel conduits for electrical wiring
	(Part 5) : 1968	PVC insulated light duty cables		IS 3837 : 1976	Accessories for rigid steel conduits for electrical wiring (<i>first revision</i>)
				IS 3419 : 1989	Fittings for rigid non-metallic conduits (<i>second revision</i>)
				IS 9537	Conduits for electrical installations
				(Part 1) : 1980	General requirements
				(Part 2) : 1981	Rigid steel conduits
				(Part 3) : 1983	Rigid plain conduits of insulating materials
				IS 14768	Conduit fittings for electrical installations
				(Part 1) : 2000	General requirements
				(Part 2) : 2003	Metal conduit fittings

<i>Sl No.</i>	<i>IS No.</i>	<i>Title</i>	<i>Sl No.</i>	<i>IS No.</i>	<i>Title</i>
	IS 14772 : 2000	General requirements for enclosures for accessories for household and similar fixed electrical installations			lations
(34)	IS 14930 (Part 1) : 2001 (Part 2) : 2001	Conduit systems for electrical installations General requirements Particular requirements — conduit systems buried underground	(40)	IS 13021(Part 1) : 1991	Specification for a.c. supplied electronic ballasts for tubular florescent lamps: Part 1 General and safety requirements
			(41)	IS 1258 : 2005	Bayonet lamp holders (<i>fourth revision</i>)
			(42)	IS 418 : 2004	Tungsten filament lamps for domestic and similar general lighting purposes (<i>fourth revision</i>)
(35)	IS 14927 (Part 1) : 2001 (Part 2) : 2001	Cable trunking and ducting systems for electrical installations General requirements Cable trunking and ducting systems intended for mounting on walls or ceiling		IS 1569 : 1976	Capacitors for use in tubular fluorescent high pressure mercury and low pressure sodium vapour discharge lamp circuit (<i>first revision</i>)
(36)	IS 9537 (Part 1) : 1980 (Part 2) : 1981	Conduits for electrical installations General requirements Rigid steel conduits		IS 2215 : 2006	Specification for starters for fluorescent lamps (<i>third revision</i>)
(37)	IS 3837 : 1976	Accessories for rigid steel conduits for electrical wiring (<i>first revision</i>)		IS 2418	Specification for tubular fluorescent lamps for general lighting service
	IS 14768 (Part 1) : 2000 (Part 2) : 2003	Conduit fittings for electrical installations General requirements Metal conduit fittings		(Part 1) : 1977	Requirements and tests (<i>first revision</i>)
				(Part 2) : 1977	Standard lamp data sheets (<i>first revision</i>)
				(Part 3) : 1977	Dimensions of G-5 and G-13 bi-pin caps (<i>first revision</i>)
	IS 14772 : 2000	General requirements for enclosures for accessories for household and similar fixed electrical installations		(Part 4) : 1977	Go and no-go gauges for G-5 and G-13 bi-pin caps (<i>first revision</i>)
(38)	IS 9537 (Part 1) : 1980 (Part 3) : 1981	Conduits for electrical installations General requirements Rigid plain conduits of insulating materials		IS 3323 : 1980	Bi-pin lampholders for tubular fluorescent lamps (<i>first revision</i>)
				IS 3324 : 1982	Holders for starters for tubular fluorescent lamps (<i>first revision</i>)
(39)	IS 3419 : 1989	Fittings for rigid non-metallic conduits (<i>second revision</i>)		IS 9900	Specification for high pressure mercury vapour lamps
	IS 14772 : 2000	General requirements for enclosures for accessories for household and similar fixed electrical instal-		(Part 1) : 1981	Requirements and tests
				(Part 2) : 1981	Standard lamp data sheets
				(Part 3) : 1981	Dimensions of lamp caps
				(Part 4) : 1981	Go and no-go gauges of lamp caps

<i>Sl No.</i>	<i>IS No.</i>	<i>Title</i>	<i>Sl No.</i>	<i>IS No.</i>	<i>Title</i>
(43)	IS 374 : 1979	Electric ceiling type fans and regulators (<i>third revision</i>)	(48)	IS/IEC 62305-4 : 2010	Protection against lightning — Part 4: Electrical and electronic systems within structures
(44)	IS 3043 : 1987	Code of practice for earthing	(49)	IS 16463 (Part 11) : 2016 IEC 61643-11 : 2011	Low-voltage surge protective devices: Part 11 Surge protective devices connected to low-voltage power systems — Requirements and test methods
(45)	IS/IEC 62305-3 : 2010	Protection against lightning — Part 3: Physical damage to structures and life hazard	(50)	IS 8437 (Part 1) : 1993 IEC Pub 479-1 (1984)	Guide on effects of current passing through the human body: Part 1 General aspects (<i>first revision</i>)
(46)	IS/IEC 62305-1 : 2010	Protection against lightning — Part 1: General principles			
(47)	IS/IEC 62305-2 : 2010	Protection against lightning — Part 2: Risk management			

NATIONAL BUILDING CODE OF INDIA

PART 8 BUILDING SERVICES

Section 3 Air Conditioning, Heating and Mechanical Ventilation

BUREAU OF INDIAN STANDARDS

CONTENTS

FOREWORD		... 3
1 SCOPE		... 7
2 TERMINOLOGY		... 7
3 REFRIGERANTS		... 11
4 PLANNING		... 12
5 OUTDOOR DESIGN CONDITIONS		... 16
6 INDOOR DESIGN CONDITIONS		... 16
7 DESIGN OF AIR CONDITIONING		... 24
8 SPECIALIZED APPLICATION		... 40
9 REFRIGERATION FOR COLD STORES		... 46
10 HEATING		... 49
11 MECHANICAL VENTILATION		... 51
12 INSTALLATION OF HVAC SYSTEM		... 62
13 SYMBOLS, UNITS, COLOUR CODE AND IDENTIFICATION OF SERVICES		... 73
14 BUILDING AUTOMATION SYSTEM FOR HVAC CONTROL, MONITORING AND VERIFICATION		... 73
15 TESTING, COMMISSIONING AND PERFORMANCE VALIDATION		... 77
ANNEX A TEMPERATURE DESIGN CONDITIONS USING ADAPTIVE MODELS		... 83
LIST OF STANDARDS		... 86

FOREWORD

This Code (Part 8/Section 3) deals with the planning, selection, design considerations, and installation of air conditioning, heating and mechanical ventilation system for different types of building application and in towns and cities under all the climatic zones of India. It covers all aspects including the goals and objectives, basis of design, input parameters for design, guidelines for design of system, performance parameters, available system options, pre-planning considerations, range of equipment and system components, building management system, installation of the system, testing, commissioning and handing over and also operation and maintenance of the air conditioning, heating and mechanical ventilation system.

Indian construction industry is poised to add an-order-of-magnitude built foot-print in the coming years. With the advent of information technology and computers becoming part of our life-style, the requirement of air conditioning of built environment is being increasingly felt and met with. The challenge faced for this unprecedented development is the lack of material resources and natural resources like energy, water and clean air. Therefore, the selection of air conditioning and mechanical ventilation system, optimally suited for the specific type of building application and its climatic zone, becomes critical. It is necessary for the owner, designer, builder and developer to understand the provisions of this Section, and consult an air conditioning engineer at the planning stage.

Sustainable buildings movement in the country has gained tremendous momentum. The Part 11 'Approach to Sustainability' of the Code, deals with all aspects of sustainable buildings, from selection of site, building design, energy and water efficient systems, use of recycled material resources, construction, third party commissioning, operation and maintenance of sustainable buildings. It is expected that by following the provisions of this Section in conjunction with those given in Part 11, India will adopt sustainable buildings as the way of life, as has been the practice for centuries, prior to the onslaught of industrial revolution in India.

Computerized weather data is now available, and has been included for around 60 locations across the country, covering all the five climatic zones. This data is based on the latest values obtained from India Metrological Department, Government of India.

This Section was first formulated in 1970 and was subsequently revised in 1983 and 2005. The major modifications made in 2005 version of the Code included addition of several new terms and their definitions; incorporation of a new clause on design criteria; inclusion of 'indoor air quality' as one of the factors that needed to be controlled in the conditioned space; incorporation of recommendation for independent air handling unit rooms for each floor of large and multi-storeyed buildings; inclusion of inside design conditions for various applications replacing earlier Table 2 and Table 3; revision of provisions on minimum outside fresh air in the light of the then accepted international norms thus covering a wider variety and a larger number of applications; addition of new details on temperature, humidity, vibration and noise; updation of provisions on application considerations, covering a wide variety of commercial applications, such as, offices, hotels, restaurants and computer rooms; inclusion of a new clause on statutory regulation/safety considerations; description of various system options available, under the clause on design considerations; updation of provisions on the characteristics and application of options available in piping, water distribution systems and piping layout; revision of provisions on air filters; revision of the clause on energy conservation and energy management to include concepts like energy targets, demand targets and consumption targets, the factors to be considered in system design that influence energy aspects, the need for analysis of operation of systems during various seasons of the year, and the need to incorporate energy recovery strategies. Apart from above, 'Automatic Controls' included in the 1983 version had been replaced by Building Management System, which addressed not only the control function, but also had a telling impact on operation and maintenance as well, most importantly on the opportunities afforded to implement various energy conservation strategies; provisions on packaged air conditioners and room air conditioners were elaborated; provisions on heating were revised; provisions on symbols, units, colour code and identification of services, pipe work services, duct work services, valve labels and charts, and also on inspection, commissioning and testing were updated; and list of various parameters to be checked for performance of air handling unit, hydronic system balancing, and

finally, the hand-over procedure were included.

Since the last revision of the Code in 2005, there has seen tremendous emphasis on energy conservation to meet the challenges posed by the climatic change. Hence the building design practices, the system components and principal equipment have gone through major development. The current revision fully recognizes the latest developments in the field of air conditioning, heating and mechanical ventilation.

The significant modifications made in this revision of this Section include amongst others, the following key changes:

- a) Definitions of several new terms have been added relating to the new concepts introduced in this revision.
- b) Clause on refrigerants has been modified to include new refrigerants with zero ozone depletion potential and ultra-low global warming potential. These are now manufactured in India and are commercially available, or are in advanced stage of development in the research and development laboratories. Water, Ammonia, CO₂, and other natural refrigerants are making a comeback and are described with relevant details.
- c) Planning considerations have been expanded to include the available options of variable refrigerant flow system; inverter technology, district cooling system, and hybrid central plant using chilled beams and radiant floor components. Planning clause also identifies the thrust on envelope optimization using energy modelling, day lighting simulation, solar shade analysis and wind modelling software to optimize the air conditioning load. Such buildings are thus designed to utilize the most energy efficient air conditioning system to bring the annual energy consumption to a minimum, which could be generated through renewable energy resources.
- d) Outdoor design conditions for air conditioning load calculation and heating requirement have been based on the latest weather data tabulated for around 60 cities, covering all the five climatic zones of India. These are derived from the latest weather data taken from India Metrological Department, Government of India.
- e) Indoor design conditions for comfort air conditioning, heating, and mechanical ventilation have been based on adaptive comfort conditions for the specific climatic zone, as per the procedure described in this completely revised clause.

The Committee explored the possibility of including heating degree day and cooling degree day in this Section. It was noted that at present, there was no scientific research in the country in public domain for arriving at heating degree day (HDD) and cooling degree day (CDD) of India and the same is being researched. It was also noted that suitable software tools were since available which provided better assessment of the cooling and heating requirements for the space. Therefore, heating degree day (HDD) and cooling degree day (CDD) was not included.

- f) The central plant equipment clause has been revised to include active and passive chilled beams, radiant floor for cooling/heating of space, underfloor air distribution to minimise stratification, geo-thermal cooling and heating, and recently developed high-efficiency cooling towers with very low approach to ambient wet-bulb temperature.
- g) Clauses on unitary/distributed equipment have been expanded and also direct/indirect evaporative cooling units have been included.
- h) Provisions for specialized applications have been further detailed where provisions have also been now included for data centres and underground metro stations.
- j) Refrigeration is common for summer air conditioning and for cold stores. Cold storage is key to India's food security by minimising food wastage. Therefore, a new clause has been introduced in this revision, on refrigeration for cold stores, describing the latest state-of-the-art technologies locally adopted.
- k) Heating is required for indoor comfort conditions during winter months in northern part of India. This clause now describes the most efficient strategies for winter heating, using reverse cycle operation, solar heating systems, electric heat pump, and ground source heat pump.
- m) Ventilation has now taken the centre-stage for sustainability in design, construction and operation of buildings. Natural ventilation and passive architecture are dealt in Part 8 'Building Services, Section 1 Lighting and Natural Ventilation' of the Code, with further strategies for sustainable buildings covered in Part 11 'Approach to Sustainability' of the Code. However, modern system of mechanical ventilation for industries, commercial kitchen, underground car parking, and for open tunnels connecting underground metro stations, has been now covered in this Section. It also covers demand control ventilation, where

fresh air input for the control of indoor air quality, varies in direct proportion to the occupancy. Newly developed axial flow fans with aerofoil profile blades and acoustic silencers, has also been covered including criteria for solution of most efficient fan for the specific application.

- n) Installation practices for the air conditioning, heating and mechanical ventilation system have been modified to suit the vast options of components now available. The clause identifies the procedure and precautions to be taken for each major component of the central system; unitary/distributed systems; fan; ducting and piping support; and for insulation. Emphasis is laid on ease of maintenance/repair/replacement; for noise and vibration isolation, and for centralized monitoring and control through computerized building automation system.
- p) Symbols, colour coding and identification of services clause has been modified to match with the international practices.
- q) Measurement and verification of building performance is now widely practiced and has put strong emphasis on integrated building management system for modern building complexes. Therefore, the clause on building automation system has been upgraded to include the latest practices for web-based monitoring and control of performance parameters.
- r) Testing, balancing, commissioning and handing over of the air-conditioning, heating and mechanical ventilation system clause has been extensively revised to include state-of-the-art procedures adopted.

This revision aims to make a difference in the quality of environment and in building usage, in response to growing concerns and expectations in with regard to indoor air quality, energy conservation, water conservation, environmental impact and building safety.

The provisions on natural ventilation are given in Part 8 ‘Building Services, Section 1 Lighting and Natural Ventilation’ of the Code.

The provisions of this Section are without prejudice to the various Acts, Rules and Regulations including *The Factories Act*, 1948 and the rules and regulations framed thereunder.

The information contained in this Section is based largely on the following Indian Standards:

IS 659 : 1964	Safety codes for air conditioning (<i>revised</i>)
IS/ISO 817	Refrigerants — Designation and safety classification (<i>second revision</i>) (<i>Under print</i>)
IS 1391	Specification for room air conditioners:
(Part 1) : 1992	Unitary air conditioners (<i>second revision</i>)
(Part 2) : 1992	Split air conditioners (<i>second revision</i>)
IS 2379 : 1990	Colour code for identification of pipelines (<i>first revision</i>)
IS 3315 : 1994	Specification for evaporative air coolers (desert coolers) (<i>second revision</i>)
IS 8148 : 2003	Specification for packaged air conditioners (<i>first revision</i>)

Assistance has also been derived from the following publications in the preparation of this Section:

- Guidelines, Standards and Handbooks of American Society of Heating, Refrigerating and Air Conditioning Engineers (ASHRAE)
- Handbooks of Indian Society of Heating, Refrigerating and Air Conditioning Engineers (ISHRAE)
- India Model for Adaptive Comfort, CEPT University, Ahmedabad
- ISO 7730 : 2005 Ergonomics of the thermal environment Analytical determination and interpretation of thermal comfort using calculation of the PMV and PPD indices and local thermal comfort criteria
- ISO 16484-1 : 2010 Building automation and control systems (BACS) Part 1: Project specification and implementation

All standards, whether given herein above or cross-referred to in the main text of this Section, are subject to revision. The parties using this Section are encouraged to investigate the possibility of applying the most recent edition of the standards.

For the purpose of deciding whether a particular requirement of this Section is complied with, the final value, observed or calculated, expressing the result of a test or analysis, shall be rounded off in accordance with IS 2 : 1960 ‘Rules for rounding off numerical values (*revised*)’. The number of significant places retained in the rounded off value should be the same as that of the specified value in this Section.

NATIONAL BUILDING CODE OF INDIA

PART 8 BUILDING SERVICES

Section 3 Air Conditioning, Heating and Mechanical Ventilation

1 SCOPE

1.1 This Code (Part 8/Section 3) covers the planning, design considerations, installation, testing, commissioning and handing over and also operation and maintenance of air conditioning, heating and mechanical ventilation systems for buildings. It also covers refrigeration for cold storages.

1.2 The provisions of this Section aim to ensure an air conditioning, heating and mechanical ventilation system which can provide comfort by managing air temperature, humidity, indoor air quality and distribution of conditioned air for the specific use and occupancy of built space while giving due consideration to minimising energy consumption and other resources.

1.3 The provisions on natural ventilation are covered in Part 8 'Building Services, Section 1 Lighting and Natural Ventilation' of the Code.

1.4 The provisions in respect of air conditioning, heating and mechanical ventilation system in sustainable buildings are covered in Part 11 'Approach to Sustainability' of the Code, which shall be used in conjunction with this Section.

2 TERMINOLOGY

For the purpose of this Section the definitions given below and those given in the accepted standard [8-3(1)] shall apply.

2.1 Air Conditioning — The process of treating air so as to control simultaneously its temperature, humidity, purity, distribution and movement and pressure to meet the requirements of the conditioned space.

2.2 Air System Balancing — Adjusting air flow rates through air distribution system devices, such as fans and diffusers, by manually adjusting the position of dampers, splitter vanes, extractors, etc, or by using automatic control devices, such as constant-air-volume or variable-air-volume (VAV) boxes.

NOTE — Air system should be balanced in order to minimise throttling losses. For fans, its speed should be adjusted to meet design flow conditions. By creating correct air flow at fans and outlet, system performance can be increased.

2.3 Atmospheric Pressure — The force per unit area exerted against a surface by the weight of the air above that surface. It is the pressure indicated by a barometer. Standard atmospheric pressure or standard atmosphere or barometric pressure is the pressure of 76 cm of

mercury column having a density of 13.595 1 g/cm³ under standard gravity of 980.665 cm/s² (10 332 mm of water column/101.325 kPa).

NOTE — Generally atmospheric pressure is used as a datum for indicating the system pressures in air conditioning and accordingly, pressures are mentioned above the atmospheric pressure or below the atmospheric pressure considering the atmospheric pressure to be zero. A 'U' tube manometer will indicate zero pressure when pressure measured is equal to atmospheric pressure.

2.4 Building Energy Simulation — Use of computer models for design and optimization of building's energy performance, to compare the cost-effectiveness of energy conservation measures in the design stage as well as assessing various performance optimization measures during the operational stage.

2.5 Building Integrated Renewable Energy — Integration of renewable energy application in parts of the building envelope such as the roof, skylights, or facades.

2.6 Building Management System (BMS) — An energy management system relating to the overall operation of the building in which it is installed. It often has additional capabilities, such as equipment monitoring, protection of equipment against power failure, and building security. It may also be a direct digital control (DDC) system where the mode of control uses digital outputs to control processes or elements directly.

NOTE — Mechanical and electrical equipment installed in the building, such as, air conditioning, ventilation, lighting, lifts, power, pumping stations, fire fighting systems, security systems are controlled and managed through BMS.

2.7 Buildings Related Illnesses (BRI) — The diagnosable illness attributed directly to the specific air-borne building contaminants, like Legionnaire's disease, occupational asthma, etc.

NOTE — Indicators of BRI include complaints of cough, chest tightness, chills, fever and muscle aches. Occupants may need prolonged recovery times after leaving the building.

2.8 Coefficient of Performance, Compressor, Heat Pump — Ratio of the compressor heating effect (heat pump) to the rate of energy input to the shaft of the compressor, in consistent units, in a complete heat pump, under designated operating conditions.

2.9 Coefficient of Performance, Compressor, Refrigerating — Ratio of the compressor refrigerating effect to the rate of energy input to the shaft of the

compressor, in consistent units, in a complete refrigerating plant, under designated operating conditions.

2.10 Coefficient of Performance (Heat Pump) — Ratio of the rate of heat delivered to the rate of energy input, in consistent units, for a complete operating heat pump plant or some specific portion of that plant, under designated operating conditions.

2.11 Coefficient of Performance (Refrigerating) — Ratio of the rate of heat removal to the rate of energy input, in consistent units, for a complete refrigerating plant or some specific portion of that plant, under designated operating conditions.

2.12 Cooling Load — Amount of cooling per unit time required by the conditioned space or product; or heat that a cooling system shall remove from a controlled system over time.

2.13 Cooling Tower — An enclosed device, often tower like, for evaporatively cooling water by contact with air.

2.14 Dedicated Outdoor Air System (DOAS) — A unit that is used to separately condition outdoor air brought into the building for ventilation or to replace air that is being exhausted.

2.15 Demand Based Ventilation — Intelligent airflow management that adjusts outside ventilation air based on the number of occupants and the ventilation demands that those occupants create.

2.16 Design Pressure Difference — The desired pressure difference between a given space and an adjacent space measured at the boundary of the given space under a specified set of conditions, such as, that required in various spaces of hospital, clean rooms, protected space in case of smoke control operation, etc.

2.17 Dew Point Temperature — The temperature at which condensation of moisture begins when the air is cooled at same pressure.

2.18 Dry-Bulb Temperature — The temperature of the air, read on a thermometer, taken in such a way as to avoid errors due to radiation.

2.19 Duct System — A continuous passageway for the transmission of air which, in addition to the ducts, may include duct fittings, dampers, plenums, grilles and diffusers.

2.20 Economizer, Air — It consist of duct, damper and control system that allow outside air to cool the building when outside air is cooler than inside.

2.21 Economizer, Water — In this system the supply air of a cooling system is cooled indirectly with water

that is itself cooled by heat transfer or mass transfer to the environment without the use of mechanical cooling.

2.22 Effective Temperature — Combined effects of air temperature, humidity, air movement, mean radiant temperature, clothing and activity on the sensation of warmth or cold felt by the human body. Numerically equivalent to the temperature of still air producing similar thermal sensation as produced by combination of above six parameters of thermal comfort.

2.23 Energy Efficiency Ratio (EER) — Ratio of net cooling capacity in BTU/h to total rate of electric input in watts under designated operating conditions.

2.24 Energy Recovery Unit — A heat exchanger assembly for transferring energy between two isolated fluid sources. The recovery system may be of air-to-air design or a closed loop hydronic system design. The system will include all necessary equipment, such as fans and pumps, associated ducts or piping and all controls (operating and safety), and other custom-designed features

2.25 Evaporative Cooling — The process of evaporating part of a liquid by supplying the necessary latent heat from the sensible heat of the main bulk of the liquid which is thus cooled.

2.26 Fire Damper — The damper, normally held open, installed in an air distribution system or in a wall or floor assembly and designed to close automatically in the event of a fire in order to maintain the integrity of the fire separation.

2.27 Geothermal Heat Pump — A heating and/or cooling system utilizes the earth's crust, as heat source (in the winter) or a heat sink (in the summer) by using fluid to be pumped into the earth and circulated in order to exchange heat for the purpose of heating or cooling applications

2.28 Global Warming Potential (GWP) — The relative measure of how much a given mass of a refrigerant contributes to global warming over a given time period compared to the same mass of carbon dioxide over the same period.

NOTE — The GWP value of carbon dioxide is taken to be 1.0. The GWP value of a refrigerant is calculated over a time horizon. The time horizon can greatly affect the numerical value of GWP. Usually the GWP values are reported over a 100 years' time horizon.

2.29 Heating Load — Heating rate required to replace heat loss from the space being controlled.

2.30 Heat Pump — A thermodynamic heating/ refrigerating system to transfer heat. The condenser and evaporator may change roles to transfer heat in either direction. By receiving the flow of air or other fluid, a heat pump is used to cool or heat. Heat pumps may be

the air source with heat transfer between the indoor air stream to outdoor air or water source with heat transfer between the indoor air stream and a hydronic source (ground loop, evaporative cooler, cooling tower, or domestic water).

2.31 Heat Recovery — Use of heat that would otherwise be wasted from a system or process, for example, heat-recovery chiller which uses hot waste gases as a heat source.

2.32 Hybrid Building — A building which contains both active and passive systems of heating or cooling. It requires small amount of non-renewable energy to maintain required amount of coefficient of performance (COP).

2.33 Hydronic Systems — The water systems that transfer heat to or from a conditioned space or process with hot or chilled water. The water flows through piping that connects a chiller or the water heater to suitable terminal heat transfer units located at the space or process.

2.34 Hydronic System Balancing — Adjusting water flow rates through hydronic distribution system devices, such as pumps and coils, by manually adjusting the position valves or by using automatic control devices, such as automatic flow control valves.

2.35 Indirect-Direct Cooling — The cooling which involves the following two stages:

- a) The first stage, in which the air is made to pass through heat exchanger for sensible cooling (no direct contact of air and water), whereby the leaving air dry-bulb temperature (DBT) as well as the wet-bulb temperature (WBT) are reduced; and
- b) The second stage, in which the air after the first stage is made to pass through the evaporative air-cooling (adiabatic cooling) application where water and air are in direct contact and there is simultaneous removal of sensible heat and the addition of moisture to the air giving lower DBT.

2.36 The resultant of this two stage cooling is that the leaving air DBT is lower than ambient WBT.

NOTE — The first stage cooling is through indirect cooling. In this method, air-dry bulb and wet-bulb temperature are reduced without direct contact of air with water and through heat exchange only.

2.37 Indoor Air Quality (IAQ) — Air quality that refers to the nature of unconditioned or conditioned air that circulates throughout the space/area where one works or lives, that is, the air one breathes when indoors.

2.38 Infiltration/Exfiltration — The phenomenon of

air leaking into (infiltration) or leaking out (exfiltration) out of an air conditioned space.

2.39 Latent Heat — Change of enthalpy during a change of state, usually expressed in kcal/kg. With pure substances, latent heat is absorbed or rejected at constant temperature at any pressure.

2.40 Latent Heat Load — Cooling load required to remove latent heat.

2.41 Mean Radiant Temperature — The uniform temperature of an imaginary enclosure in which the radiant heat transfer from the human body is equal to the radiant heat transfer in the actual non-uniform enclosure.

2.42 Mixed Mode Building — A hybrid approach to space conditioning that uses a combination of natural ventilation and mechanical systems. These buildings utilize mechanical cooling only when and where it is necessary to supplement the natural ventilation.

2.43 Naturally Conditioned Building — A building in which the ventilation system rely on opening and closing of window of the space to maintain the thermal comfort of the space rather than mechanical systems.

2.44 Operative Temperature — A uniform temperature of a radiantly black enclosure in which an occupant would exchange the same amount of heat by radiation plus convection as in the actual non-uniform environment. It is the combined effects of the mean radiant temperature and air temperature calculated as average of the two. It is also known as dry resultant temperature or resultant temperature.

2.45 Ozone Depletion Potential (ODP)—A relative capability of a refrigerant or a gas to degrade ozone in the atmosphere as compared to trichlorofluoromethane [R-11 or Chlorofluorocarbon-11(CFC-11)]. The ODP of CFC-11 is taken to be 1.0.

2.46 Passive Cooling — A building design approach that focuses on heat gain control and heat dissipation in a building in order to improve the indoor thermal comfort with low or zero energy consumption by using natural ventilation, air cooling and shades.

2.47 Passive Heating — Passive heating uses the energy of natural source such as the sun, to keep the occupants of the building comfortable by design approach of building without the use of mechanical or electrical heating systems.

2.48 Plenum — An air compartment connected to one or more distributing ducts.

2.49 Positive Ventilation — The supply of outside air by means of a mechanical device, such as a fan.

2.50 Psychrometric Chart — A chart graphically representing the thermodynamic properties of moist air.

2.51 Recirculated Air — The return air that has been passed through the conditioning apparatus before being re-supplied to the space.

2.52 Refrigerant — The fluid used for heat transfer in a refrigerating system, which absorbs heat at a low temperature and a low pressure of the fluid and rejects heat at a higher temperature and a higher pressure of the fluid, usually involving changes of state of the fluid.

2.53 Relative Humidity — Ratio of the partial pressure of actual water vapour in the air as compared to the partial pressure of maximum amount of water that may be contained at its dry-bulb temperature.

NOTE — When the air is saturated, dry-bulb, wet-bulb and dew point temperatures are all equal, and the relative humidity is 100 percent.

2.54 Return Air — Air returned from conditioned or refrigerated space.

2.55 Sensible Heat — Heat which is associated with a change in temperature; in contrast to a heat interchange in which a change of state (latent heat) occurs.

2.56 Sensible Cooling — The process of removing sensible heat (lowering the dry-bulb temperature) from the air passing through it under specified conditions of operation.

2.57 Shade Factor — The ratio of instantaneous heat gain through the fenestration with shading device to that through the fenestration.

2.58 Sick Building Syndrome (SBS) — A term used to describe the presence of acute non-specific symptoms in the majority of people, caused by working in buildings with an adverse indoor environment.

NOTE — SBS could be a cluster of complex irritative symptoms like irritation of the eyes, blocked nose and throat, headaches, dizziness, lethargy, fatigue irritation, wheezing, sinusitis, congestion, skin rash, sensory discomfort from odours, nausea, etc. These symptoms are usually short-lived and experienced immediately after exposure; and may disappear when one leaves the building.

2.59 Smoke Barrier — A continuous membrane, either vertical or horizontal, such as a wall, floor, or ceiling assembly, that is designed and constructed to restrict the movement of smoke in conjunction with a smoke control system.

2.60 Smoke Damper — A damper similar to fire damper, however, having provision to close automatically on sensing presence of smoke in air distribution system or in conditioned space.

2.61 Smoke Management — A smoke control method

that utilizes natural or mechanical systems to maintain a tenable environment for the means of egress from a large-volume space or to control and reduce the migration of smoke between the area on fire and communicating spaces.

2.62 Stack Effect — The vertical airflow within buildings caused by the temperature-created density differences between the building interior and exterior or between two interior spaces.

2.63 Static Pressure — The normal force per unit area that would be exerted by a moving fluid on a small body immersed in it if the body were carried along with the fluid. Practically, it is the normal force per unit area at a small hole in a wall of the duct through which the fluid flows (piezometer) or on the surface of a stationary tube at a point where the disturbances, created by inserting the tube, cancel. It is supposed that the thermodynamic properties of a moving fluid depend on static pressure in exactly the same manner as those of the same fluid at rest depend upon its uniform hydrostatic pressure.

2.64 Supply Air — The air that has been passed through the conditioning apparatus and taken through the duct system and distributed in the conditioned space.

2.65 Terminal Devices — Devices fixed in the air conditioned space for distribution of conditioned supply air and return of air such as, supply and return air grilles and diffusers.

2.66 Thermal Adaptation — The gradual diminution of the people's response to repeated environmental stimulation and subsumes all processes which building occupants undergo in order to improve the fit of the indoor climate.

2.67 Thermal Comfort — That condition of mind which expresses satisfaction with the thermal environment and is assessed by subjective evaluation.

2.68 Thermal Insulation Material — A material used over the conducting material to retard the flow of heat energy in the form of heat loss or gain to facilitate the temperature control as the process and prevent permeability of moist vapour and reduces condensation on cold surfaces.

2.69 Thermal Energy Storage — Storage of thermal energy, sensible, latent or combination thereof for use in central system for air conditioning or refrigeration. It uses a primary source of refrigeration for cooling and stored thermal energy for reuse at peak demand or for backup as planned.

2.70 Velocity Pressure — The pressure exerted by movement of air which makes the air to travel to longer

distance in ducts. This pressure is always in the direction of flow.

2.71 Variable Refrigerant Flow (VRF) System — A heating and/or cooling system in which the flow of the refrigerant can be varied according to the load.

2.72 Water Hardness — The hardness in water represented by the sum of calcium and magnesium salts in water, which may also include aluminium, iron, manganese, zinc, etc.

2.73 Water Treatment — The treatment of water circulating in a hydronic system, so that it can be used without creating undue corrosion or scaling to the piping systems and other deleterious effects.

2.74 Wet-Bulb Temperature — The temperature at which liquid or solid water, by evaporating into air, can bring the air to saturation adiabatically at the same temperature. Wet-bulb temperature is the temperature indicated by a wet-bulb thermometer constructed and used according to specifications.

3 REFRIGERANTS

3.1 Refrigerants are classified into two classes based on their toxicity, namely Class A having lower chronic toxicity and Class B having higher chronic toxicity. They are classified into four classes based on their flammability, namely, Class 1 (no flame propagation), Class 2L (lower flammability), Class 2 (flammable) and Class 3 (higher flammability).

Refrigerants shall be designated and classified for safety in accordance with the accepted standard [8-3(2)].

3.1.1 Matrix Diagram of Safety Group Classification System

The toxicity and flammability classifications for refrigerants as per 3.1 yield eight safety groups, namely, A1, A2L, A2, A3, B1, B2L, B2 and B3. These safety groups are represented by the matrix shown below:

Toxicity →	Safety Group	
	Lower Toxicity	Higher Toxicity
Flammability ↓		
Higher flammability	A3	B3
Flammable	A2	B2
Lower flammability	A2L	B2L
No flame propagation	A1	B1

3.2 While selecting refrigerants, manufacturers and designers shall adopt balanced approach considering environmental impact and human health. The key criteria that shall be considered are as follows:

- a) *Ozone depletion potential (ODP)* — ODP of the refrigerant should preferably be zero and shall be as permitted under *The Ozone Depleting Substances (Regulation and Control) Amendment Rules, 2014* as amended from time to time (see Note);
- b) *Global warming potential (GWP)* — GWP of the refrigerant should preferably be low to reduce greenhouse gas (GHG) emissions, which is in line with the on-going discussion for phase-down of production and consumption of Hydrofluorocarbons (HFCs);
- c) Refrigerant with zero ODP and low GWP should be adopted for balance approach considering overall environmental impact;
- d) *Flammability* — The refrigerant should preferably be non-flammable/having flammability as low as possible, and suitable risk mitigation process/infrastructure (sensors, ventilation, etc) should be opted to mitigate the risk of flammability, if any, in line with the accepted standards;
- e) *Toxicity* — The refrigerant should have toxicity as low as possible, and suitable risk mitigation strategies/infrastructure (sensors, ventilation, etc) should be opted to handle toxicity, if any in line with the accepted standards; and
- f) The refrigerant should also support other key performance parameters, including high energy efficiency, low emissions, chemical and thermal stability and material compatibility.

NOTE — The production and consumption of ozone depleting substances (ODS) including HCFCs, for example, HCFC-22 and HCFC-123 is being phased out by 2030. The import of refrigeration and air conditioning equipment containing HCFCs has already been banned from 01 July 2015, and the manufacturing of all such equipment with HCFC will be banned in the country from 01 January 2025 in accordance with *The Ozone Depleting Substances (Regulation and Control) Amendment Rules, 2014*.

For ODP, GWP and safety group (flammability and toxicity) of different refrigerants, reference shall be made to Table 1. As there are ongoing developments with respect to refrigerants with HCFC Phase-out Management Plan (HPMP) and HFC phase down proposals, latest regulations applicable at the time of selection of equipment/systems with various possible refrigerants shall be followed. As research is going on for alternative refrigerants to various HCFC/HFC/HFO refrigerants, it is recommended that project teams should make a conscious effort to select equipment/systems with refrigerant with high energy efficiency, least negative impacts on health, safety and environment as per the latest developments.

Table 1 ODP and GWP Values (100 Year Values) and Safety Group of Different Refrigerant Types (Clause 3.2)

Sl No.	Refrigerant		ODP	GWP	Safety Group {see Accepted Standard [8-3(2)]}
	Refrigerant Number	Composition Designating Prefix			
(1)	(2)	(3)	(4)	(5)	(6)
i)	Hydrochlorofluorocarbons (HCFC):				
a)	R-22	HCFC	0.055	1 810	A1
b)	R-123	HCFC	0.02	77	B1
ii)	Hydrofluorocarbons (HFC) and their blends:				
a)	R-32	HFC	0	677	A2L
b)	R-134a	HFC	0	1 430	A1
c)	R-245fa	HFC	0	858	B1
d)	R-404A	HFC	0	3 922	A1
e)	R-407C	HFC	0	1 774	A1
f)	R-407F	HFC	0	1 825	A1
g)	R-410A	HFC	0	2 088	A1
h)	R-507A	HFC	0	3 985	A1
j)	R-448A	HFC	0	1 386	A1
iii)	Hydrofluoroolefins (HFO):				
a)	R-1233zd(E)	HFO	~0	1	A1
b)	R-1234ze(E)	HFO	0	0.97	A2L
c)	R-1234yf	HFO	0	0.31	A2L
d)	R-1336mzz(Z)	HFO	0	2.0	A1
e)	R-514A	HFO	0	1.75	B1
iv)	Hydrofluoroolefins (HFO)/Hydrofluorocarbons (HFC) Blends:				
a)	R-452A	HFO and HFC blend	0	2141	A1
b)	R-452B	HFO and HFC blend	0	675	A2L
c)	R-513A	HFO and HFC blend	0	573	A1
v)	Natural refrigerants:				
a)	R-718 (Water)	-	0	0	A1
b)	R-744 (Carbon dioxide)	-	0	1	A1
c)	R-717 (Ammonia)	-	0	0	B2L
d)	R-290 (Propane)	HC	0	3.3	A3

3.3 Suggested list of refrigerants which may be used for various applications is given below (see also Note under 3.2):

- a) *Air conditioning:*
 - 1) *Residential, small unitary light commercial, VRF application* — R-22, R-32, R-410A, R-452B and R-290.
 - 2) *Chillers for comfort, industrial and process application* — R-123, R-134a, R-245fa, R-407C, R-513A, R-1233zd(E), R-514A, R-1234ze(E), R-1234yf, R-717 and R-718.
 - 3) *Transport, mobile application* — R-134a, R-407C and R-1234yf.
- b) *Refrigeration:*

- 1) *Stationary and transport, mobile application* — R-744, R-717, R-404A, R-452A, R-134a, R-290.

4 PLANNING

4.1 Fundamental Requirements

4.1.1 The objective of installing air conditioning, heating and mechanical ventilation in buildings shall be to provide comfortable conditions without compromising on health and safety of occupants.

4.1.2 Air conditioning, heating and mechanical ventilation installation shall aim at controlling and optimizing the following factors in the building:

- a) Air quality
- b) Air movement,
- c) Dry-bulb temperature,
- d) Relative humidity,
- e) Noise and vibration,
- f) Energy efficiency, and
- g) Fire safety.

4.1.3 All plans, design drawings, specifications and data for air conditioning, heating and mechanical ventilation systems of all buildings and serving all occupancies within the scope of the Code, shall be supplied to the Authority, where called for (see Part 2 ‘Administration’ of the Code).

4.1.4 The plans and design drawings for air conditioning, heating and mechanical ventilation (HVAC) systems shall include all details and data necessary for review of installation such as,

- a) building: name, type and location;
- b) owner: name;
- c) use of building;
- d) orientation: north direction on plans and design drawings;
- e) general plans: dimensions and height of all rooms;
- f) intended use of internal spaces;
- g) detail or description of wall construction, including insulation and finish;
- h) detail or description of roof, ceiling and floor construction, including insulation and finish;
- j) detail or description of windows and outside doors, including sizes, weather stripping, storm sash, sills and storm doors;
- k) internal load, such as people, equipment, computer/server load and lighting load;
- m) layout showing the location, size and components of the HVAC equipment being installed;
- n) information regarding air distribution system;

- p) information on air and water flow rates;
- q) information regarding location, size and accessibility of shafts;
- r) information regarding type and location of dampers (both volume control and fire/smoke dampers) used in air conditioning system, such as, whether motorized or manually operated;
- s) location and grade of the required fire separations;
- t) water softening arrangement; and
- u) Information on presence of any chemical fumes or gases.

4.2 Design Considerations

4.2.1 Cooling and heating load estimate shall be carried out prior to design and installation of HVAC equipment. Calculation of cooling and heating load shall take into account the following factors:

- a) Recommended indoor temperature, relative humidity, air velocity, mean radiant temperature, clothing and activity;
- b) Outside design conditions as specified in 5;
- c) Details of building construction and orientation of exposures of building components;
- d) Fenestration area, thermal properties and shading factors;
- e) *Occupancy* — Number of people and their schedule of activities;
- f) *Ventilation* — Requirement for fresh air;
- g) Infiltration, air leakage;
- h) *Internal load* — Equipment, computer/server and lighting;
- j) Effective volume; and
- k) Occupancy, lighting and equipment schedule.

4.2.2 The design of air conditioning, heating and mechanical ventilation system and its associated controls shall also take into account the following:

- a) Nature of application,
- b) Permissible control limits,
- c) Fire safety,
- d) Opportunities for heat recovery,
- e) Energy efficiency,
- f) Filtration standard,
- g) Hours of use,
- h) Suitable diversity factor based on usage,
- j) Outdoor and indoor air quality, and
- k) Availability of make-up water for cooling towers.

4.2.3 Due consideration shall also be given to air conditioning load encountered during off-peak hours

including night time and weekend/holidays.

4.2.4 Consideration shall be given to the anticipated future changes, permanent or temporary, in building load and the system shall be so designed that maximum operational efficiency is maintained throughout.

4.2.5 Special applications like hospitals/operating theatres, computer rooms, data centers and telecommunication rooms, clean rooms, laboratories, libraries, museums/art galleries, sound recording studios, etc, shall be handled differently.

4.2.6 Computer based hourly load calculation and energy simulation tools may be used for HVAC equipment sizing and to identify effect of various energy conservation measures on energy consumption.

4.3 Equipment Room for Central Air Conditioning Plant

4.3.1 This room shall be located preferably within the building being air conditioned and closer to external wall for facilitating ventilation and equipment movement. The equipment may also be installed in a separate service block which should also be located as close as possible to the load/building being conditioned. The clear headroom below soffit of beam should be minimum 4.5 m for larger capacity chillers (500 TR and above) and minimum 3.6 m for smaller plants.

4.3.2 The floors of the equipment rooms should be finished smooth. For floor loading, the air conditioning engineer should be consulted (*see also* Part 6 ‘Structural Design, Section 1 Loads, Forces and Effects’ of the Code).

4.3.3 Supporting of pipe within plant room spaces should be normally from the floor. However, outside plant room areas, structural provisions shall be made for supporting the water pipes from the floor/ceiling slabs. All floor and ceiling supports shall be isolated from the structure to prevent transmission of vibrations.

4.3.4 Equipment rooms, wherever necessary, shall have provision for mechanical ventilation. In hot and dry climate, evaporative air cooling may also be considered.

4.3.5 Plant machinery in the plant room shall be placed on levelled plain/reinforced cement concrete foundation block and provided with anti-vibratory supports or alternatively on inertia bases. Supports for appliances shall be designed and constructed to sustain vertical and horizontal loads within the stress limitations specified in the Part 6 ‘Structural Design’ of the Code. All foundations should be protected from damage by providing epoxy coated angle nosing. Seismic restraints requirement should also be considered (*see also* 12.6.4).

4.3.6 Appropriate sound insulation and noise control measures shall be taken in plant room space as per

Part 8 'Building Services, Section 4 Acoustics, Sound Insulation and Noise Control' of the Code. Acoustic treatment as may be required shall be provided in plant room space in accordance with 12.1.9 to prevent noise transmission to adjacent occupied areas.

4.3.7 In case air conditioning plant room is located in basement, equipment movement route shall be planned to facilitate future replacement and maintenance. Service ramps or hatch in ground floor slab should be provided in such cases. Fire egress and emergency battery backup lighting shall be provided for the plant room operator.

4.3.8 Floor drain channels or dedicated drain pipes in slope shall be provided within plant room space for effective disposal of waste water, if necessary by automatic level controlled sump pumps. Fresh water connection may also be provided in the air conditioning plant room.

4.3.9 Thermal Energy Storage

Thermal storage may be used for limiting maximum demand, by controlling peak electricity load through reduction of chiller capacity, and by taking advantage of high system efficiency during low ambient conditions. Thermal storage will also help in reducing operating cost by using differential time-of-the day power tariff, where applicable.

In case of central plant designed with thermal energy storage, its location shall be decided in consultation with the air conditioning engineer. For roof top installations, structural provision shall take into account load coming on the building/structure due to the same. For open area surface installation, horizontal or vertical system options shall be considered and approach ladders for manholes provided. Buried installation shall take into account loads due to movement of vehicles above the area. Provision for adequate expansion tank and its connection to thermal storage tanks shall be made.

4.4 Equipment Room for Air Handling Units and Package Units

4.4.1 This shall be located as centrally as possible to the conditioned area and contiguous to the corridors or other service areas for carrying air ducts in ceiling spaces.

4.4.2 In case of special and high-rise buildings, air handling units shall be provided in accordance with Part 4 'Fire and Life Safety' of the Code. Air handling unit rooms should preferably be located vertically one above the other.

4.4.3 Provision shall be made for the entry of outdoor ventilation air into air handling unit room. For energy

conservation, it is desirable to install mechanism for modulating the outdoor air quantity based on demand.

4.4.4 Exterior openings for outdoor air intake and also exhaust outlets shall have louvers having rain protection profile, with volume control damper, pre-filter and bird screen.

4.4.5 In all cases, outdoor air intakes shall be so located as to avoid contamination from exhaust outlets and from the sources in concentration greater than normal in the locality in which the building is located. It is recommended to maintain minimum 8 m separation between outdoor air intake points and exhaust outlets.

4.4.6 Exhaust air from any dwelling unit shall not be circulated/ingress directly or indirectly to any other dwelling unit, to public corridor or into public stairway.

4.4.7 All air handling rooms should have floor drains and if possible, water supply connection. The trap in floor drain shall provide a water seal between the air conditioned space and the drain line.

4.4.8 Supply/return air duct serving other areas shall not be taken through fire exits.

4.4.9 Waterproofing of air handling unit rooms shall be carried out to prevent damage to floor below.

4.4.10 The floors should be finished smooth. For floor loading, the air conditioning engineer should be consulted (*see also* Part 6 'Structural Design, Section 1 Loads, Forces and Effects' of the Code).

4.4.11 Structural design should avoid beam obstruction to the passage of supply and return air ducts. Adequate ceiling space should be made available outside the air handling unit room to permit installation of supply and return air ducts and fire/smoke dampers at compartment wall crossings.

4.4.12 Appropriate sound insulation and noise control measures shall be taken in air handling unit rooms, if located in close proximity to occupied areas, as per Part 8 'Building Services, Section 4 Acoustics, Sound Insulation and Noise Control' of the Code. The air handling unit rooms shall be acoustically treated in accordance with 12.1.9, if located in close proximity to occupied areas.

4.4.13 Access door to air handling unit room shall be single/double leaf type, air tight, opening outwards and should have a sill to prevent flooding of adjacent occupied areas. It is desired that access panels in air conditioned spaces should be provided with tight sealing, gaskets and self-closing devices for air conditioning to be effective.

4.4.14 It should be possible to isolate the air handling

unit room in case of fire. The door shall be fire resistant (*see* Part 4 'Fire and Life Safety' of the Code) and fire/smoke dampers shall be provided in supply/return air duct at air handling unit room wall crossings. Annular space between the duct and the wall should be fire-sealed using appropriate fire resistance rated material.

4.4.15 Fire isolation shall be provided for vertical fresh air duct, connecting several floors.

4.4.16 It is desirable that individual air handling unit should be installed for each fire compartment, alternately, fire barrier should be provided at each fire separation for air handling units serving more than one compartment.

4.5 Pipe Shafts

4.5.1 The shafts carrying chilled water pipes should be located adjacent to air handling unit room or within the room.

4.5.2 Shaft carrying condensing water pipes to cooling towers located on terrace should be vertically aligned.

4.5.3 All shafts shall be provided with fire barrier at floor crossings (*see* Part 4 'Fire and Life Safety' of the Code).

4.5.4 Access to shaft shall be provided at every level, if there is any serviceable component in the shaft.

4.5.5 In case of tall buildings, care shall be taken for expansion/contraction of pipes while planning the supports.

4.6 Supply Air Ducts and Return Air Ducts

4.6.1 The duct supports shall be designed to handle the load and also to take into account seismic considerations. The support material should be galvanized steel/aluminium and facilitate ease of installation at site using alternatives such as fully threaded rod/angle section/wire support systems using stud anchors provided in the ceiling slab from drilled holes without damaging the slab or structural member.

4.6.2 If false ceiling is provided, the supports for the duct and the false ceiling, shall be independent. Collars for grilles and diffusers shall be taken out only after false ceiling/boxing framework is done and frames for fixing grilles and diffusers have been installed. Flexible ducts may be used for making the final connections.

4.6.3 Where a duct penetrates the masonry wall, it shall either be suitably covered on the outside to isolate it from masonry, or an air gap shall be left around it to prevent vibration transmission. Further, where a duct passes through a fire resisting compartment/barrier, the annular space shall be sealed with fire sealant to prevent smoke transmission (*see* Part 4 'Fire and Life Safety' of the Code).

4.7 Cooling Tower

4.7.1 Cooling towers are used to dissipate heat from water cooled refrigeration, air conditioning and industrial process systems to the atmosphere. Cooling is achieved by evaporating a small proportion of recirculating water into outdoor air stream. Cooling towers shall be installed at a place where free flow of atmospheric air is available.

4.7.2 Range of a cooling tower is defined as temperature difference between the entering and leaving water. Approach of the cooling tower is the difference between leaving water temperature and the ambient air wet-bulb temperature.

4.7.3 Selection of Cooling Tower

Following factors shall be considered for selection of cooling tower:

- a) Design wet-bulb temperature and approach of cooling tower. The designer shall endeavour for reducing the approach for maximizing the energy conservation potential;
- b) Height limitation and aesthetic requirement;
- c) Location of cooling tower considering possibility of easy drain back from the system;
- d) Placement with regard to adjacent walls, windows and other buildings, and effects on these from any water carried over by the air stream;
- e) Vibration and noise levels, particularly during silent hours;
- f) Material of construction for the tower;
- g) Direction and flow of prevailing wind;
- h) Quality of water used for make-up;
- j) Maintenance and service space availability; and
- k) Ambient air quality.

4.7.4 The recommended floor area requirement for various types of cooling tower is as given below:

- a) Natural draft : 0.15 to 0.20 m²/TR cooling tower
- b) Mechanical draft : 0.07 to 0.10 m²/TR cooling tower

4.7.5 Structural provision for the cooling tower shall be taken into account while designing the building. Vibration isolation shall be an important consideration in structural design.

4.7.6 Special care should be taken in design where noise transmitted to the adjoining building can be of serious concern. Special vibration control and sound attenuation devices may be required in that case. Appropriate sound insulation and noise control

measures shall be taken in such cases in accordance with Part 8 'Building Services, Section 4 Acoustics, Sound Insulation and Noise Control' of the Code.

4.7.7 Certain amount of water is lost from circulating water in the cooling tower, as given below:

- a) *Evaporation loss* — It is usually about 1 percent of the rate of water circulation.
- b) *Drift loss* —The drift loss shall be below 0.1 percent of rate of water circulation.
- c) *Blow-down/bleed-off*—The amount of blow-down shall be below 0.8 percent of the total water circulation. If simple blow-down is inadequate to control scale formation, chemicals may be added to inhibit corrosion and limit microbiological growth.

Provision shall be made to make-up for the loss of circulating water.

4.7.8 Provision for make-up water tank to the cooling tower shall be made. Make-up water tank to the cooling tower shall be separate from the tank serving drinking water. Makeup water should be sourced from treated water from sewage treatment, waste water treatment plant, or from rain water harvesting.

Make-up water having contaminants or hardness, which can adversely affect the refrigeration plant life, shall be treated. Treated water where hardness as ppm of CaCO₃ is reduced to 50 ppm or below is recommended for air conditioning applications. Water with pH value less than 5 shall also need to be treated. For treatment of water for cooling towers, reference shall be made to the good practice [8-3(3)].

4.7.9 Cooling tower should be so located as to eliminate nuisance from drift to adjoining structures.

4.8 Building Envelope

The envelope of the building including wall, roof and fenestration shall be planned as per Part 11 'Approach to Sustainability' of the Code.

4.9 Fire Safety

For fire safety in case of special and high-rise buildings, provisions of Part 4 'Fire and Life Safety' of the Code shall be applicable.

4.10 Sound Insulation and Noise Control

Sound insulation and noise control measures for HVAC system shall be in accordance with Part 8 'Building Services, Section 4 Acoustics, Sound Insulation and Noise Control' of the Code.

4.11 Energy Conservation

Designers shall aim for energy efficiency in buildings

with the right blend of passive and active design strategies in accordance with Part 11 'Approach to Sustainability' of the Code, so as to minimise the energy use while ensuring comfort as per adaptive thermal comfort requirement given in 6.

5 OUTDOOR DESIGN CONDITIONS

The outdoor design conditions shall be considered in accordance with Table 2. For cities not included in this table, it is recommended that extrapolation may be done, from the data of the nearby listed city, but keeping into consideration the specific topographical and climatic conditions of the concerned location. Values of ambient dry-bulb temperatures and wet-bulb temperatures, against the various annual percentiles, represent the value that is exceeded on average by the indicated percentage of the total number of hours. The 0.4 percent, 1.0 percent, 2.0 percent values are exceeded on average 35 h, 88 h and 175 h, respectively in a year. The 99.0 percent and 99.6 percent values are defined in the same way but are usually reckoned as the values for which the corresponding weather elements are less than the design conditions of 88 h and 35 h, respectively.

Mean coincidental values are the average of the indicated weather element occurring concurrently with the corresponding design value. After the calculation of design dry-bulb temperatures, the programme located the values of corresponding wet-bulb temperatures from the database for that particular station, the average of these values were computed, which were then called mean of coincidental wet-bulb temperature. In the same way, design wet-bulb temperatures and coincidental dry-bulb temperatures were evaluated.

The design values of 0.4 percent, 1.0 percent and 2.0 percent annual cumulative frequency of occurrence may be selected depending upon application of air conditioning system. For normal comfort conditions, values under 1.0 percent column should be used for cooling loads and 99 percent column for heating loads. For critical applications, values under 0.4 percent column should be used for cooling loads and 99.6 percent column for heating loads.

6 INDOOR DESIGN CONDITIONS

6.1 One of the primary objectives of designing indoor environment is to ensure thermal comfort of all occupants. Air conditioning, heating and mechanical ventilation (HVAC) system is employed to achieve thermal comfort inside building, when means to achieve the same only through building design is limited.

According to the internationally accepted definition, thermal comfort is that state of mind which expresses satisfaction with the indoor environment. The above

Table 2 Summary for Outdoor Design Conditions
(Clause 5.1)

Sl No.	Location Name	Cooling DB/MCWB						Evaporation WB/MCDB						Heating DB	
		0.4 Percent		1.0 Percent		2.0 Percent		0.4 Percent		1.0 Percent		2.0 Percent		99.6 Percent	99.0 Percent
		DB	MCWB	DB	MCWB	DB	MCWB	WB	MCDB	WB	MCDB	WB	MCDB		
		(3)	(4)	(5)	(6)	(7)	(8)	(9)	(10)	(11)	(12)	(13)	(14)	(15)	(16)
1)	Ahmedabad	42.1	23.0	41.0	22.8	39.9	22.9	28.5	33.7	28.0	32.7	27.5	32.1	11.0	12.3
2)	Akola	43.2	22.0	42.0	21.7	40.9	21.5	26.8	34.3	26.2	32.1	25.7	31.0	12.9	14.1
3)	Allahabad	43.7	23.4	42.2	23.5	40.8	22.7	28.8	33.0	28.4	32.8	28.0	32.6	7.9	9.1
4)	Amritsar	42.2	23.8	40.9	23.6	39.2	23.5	29.1	33.9	28.7	33.6	28.3	33.2	2.0	3.2
5)	Aurangabad	40.2	22.6	39.2	22.7	38.2	22.4	26.6	35.2	25.7	33.1	25.1	31.7	10.6	12.0
6)	Barmer	43.1	24.2	42.0	23.6	41.0	23.3	28.5	37.9	27.8	35.3	27.2	33.3	9.5	10.7
7)	Belgaum	36.4	19.2	35.4	19.3	34.4	19.4	24.0	29.3	23.6	28.4	23.2	27.6	13.3	14.5
8)	Bengaluru	34.2	19.8	33.4	19.8	32.6	19.8	23.6	28.9	23.1	28.3	22.7	27.7	15.2	15.9
9)	Bhagalpur	42.4	26.8	40.7	27.4	38.9	25.6	30.0	37.1	29.6	36.4	29.2	35.2	11.4	12.6
10)	Bhopal-Bairagarh	41.8	21.6	40.6	21.4	39.4	21.3	26.2	31.5	25.8	30.7	25.4	30.0	10.0	11.2
11)	Bhubaneshwar	38.6	26.6	37.3	26.6	36.2	26.5	29.4	34.1	29.0	33.6	28.6	32.9	14.0	15.1
12)	Bhuj	41.0	23.9	39.7	23.8	38.5	23.9	28.8	34.8	28.3	33.8	27.8	32.9	8.0	9.8
13)	Bikaner	44.2	21.3	42.9	22.0	41.6	22.3	28.2	34.4	27.6	33.8	27.1	33.4	5.6	7.0
14)	Chennai-Minambakkam	38.7	25.9	37.2	25.8	36.2	25.8	28.4	33.1	28.0	32.3	27.6	31.9	19.9	20.8
15)	Chitradurga	36.2	20.8	35.4	20.8	34.6	20.9	25.5	31.4	24.7	30.4	24.1	29.5	15.8	17.0
16)	Dehradun	37.7	21.6	36.2	21.3	34.7	21.4	26.8	30.3	26.4	29.9	26	29.5	5.3	6.4
17)	Dibrugarh	34.0	27.0	33.2	26.8	32.3	26.7	28.3	32.6	27.8	31.8	27.4	31.3	7.5	8.7
18)	Gorakhpur	41.4	26.2	40.3	26.0	39.1	26.4	29.9	35.2	29.7	35.5	29.4	34.7	7.9	9.0
19)	Guwahati	34.5	26.5	33.6	26.5	32.8	26.5	28.7	32.7	28.2	31.9	27.9	31.3	10.8	11.8
20)	Gwalior	43.7	22.0	42.6	22.3	41.3	22.2	28.2	32.9	27.8	32.2	27.4	31.7	6.0	7.1
21)	Hissar	44.6	23.8	43.2	23.9	41.7	24.0	29.1	35.7	28.7	35.2	28.2	34.5	6.1	7.2
22)	Hyderabad	40.2	21.8	39.1	21.7	38.0	21.8	25.7	31.5	25.1	30.8	24.7	30.2	13.9	15.1
23)	Imphal	31.1	23.3	30.2	23.5	29.6	22.9	25.0	29.5	24.6	28.6	24.3	28.3	3.9	5.0
24)	Indore	40.8	19.7	39.6	19.8	38.4	19.7	25.6	30.3	29.6	25.1	24.7	29.0	9.1	10.4
25)	Jabalpur	42.4	20.7	41.1	20.7	39.7	21.0	26.7	31.4	26.2	30.4	25.7	29.6	8.4	9.6
26)	Jagdalpur	39.3	22.5	38.0	22.6	36.8	22.5	26.3	31.5	25.7	30.5	25.4	29.9	9.9	11.2
27)	Jaipur-Sanganer	42.5	21.3	41.2	21.3	40.0	21.3	27.5	31.2	27.0	30.9	26.6	30.5	7.2	8.6
28)	Jaisalmer	43.5	23.9	42.3	23.8	41.1	23.8	28.0	35.3	27.5	34.8	27.1	34.4	8.4	9.7
29)	Jamnagar	37.1	24.4	36.1	25.6	35.3	25.1	29.2	33.0	28.4	32.5	27.9	32.0	10.0	11.7
30)	Jodhpur	42.7	21.2	41.4	21.6	40.2	21.8	27.5	32.4	27.1	32.1	26.7	31.8	8.8	10.1
31)	Jorhat	34.4	28.2	33.6	27.7	32.9	27.3	28.7	32.7	28.3	32.7	28.0	31.8	9.6	10.6
32)	Kolkata-Dum-Dum	37.4	27.0	36.3	27.0	35.4	26.8	29.6	34.5	29.1	33.8	28.7	33.0	11.5	12.7
33)	Kota	43.5	23.0	42.4	22.6	41.2	22.6	27.3	35.2	26.8	33.0	26.5	31.8	9.9	10.8
34)	Kurnool	41.5	23.0	40.5	23.1	39.4	22.9	26.2	33.7	25.8	32.9	25.4	32.2	17.0	18.0

Table 2 — (Concluded)

(1)	(2)	(3)	(4)	(5)	(6)	(7)	(8)	(9)	(10)	(11)	(12)	(13)	(14)	(15)	(16)
35)	Lucknow-Amausi	42.1	22.8	40.8	22.8	39.2	23.5	29.2	33.8	28.8	33.2	28.4	32.5	6.9	8.1
36)	Mangalore	34.3	24.9	33.8	24.9	33.2	24.7	27.1	31.3	26.7	30.8	26.5	30.5	20.6	21.4
37)	Mumbai-Santacruz	35.9	22.7	34.9	23.1	33.9	23.4	27.7	31.2	27.4	30.9	27.1	30.6	16.8	18.0
38)	Nagpur-Sonegaon	43.9	22.5	42.8	22.4	41.4	22.2	27.4	32.3	26.8	31.6	26.4	31.0	11.8	13.0
39)	Nellore	40.7	26.8	39.2	27.1	38.0	26.9	29.0	35.8	28.5	34.9	28.1	34.1	20.4	21.1
40)	New-Delhi-Safdarjung	42.2	22.7	40.7	22.9	39.4	23.1	28.7	34.0	28.2	33.4	27.9	32.9	6.2	7.2
41)	Panjim	34.1	25.6	33.5	25.6	33.0	25.5	28.2	31.9	27.7	31.3	27.4	30.9	19.7	20.4
42)	Patna	41.0	23.4	39.5	23.4	37.9	23.8	28.9	33.7	28.6	33.0	28.2	32.3	8.2	9.3
43)	Pune	38.1	19.7	37.1	19.6	36.0	19.7	24.6	29.8	24.2	29.0	23.7	28.3	9.7	10.9
44)	Raipur	43.6	23.3	42.2	23.3	40.8	23.0	27.1	31.8	26.8	32.0	26.5	31.2	11.3	12.6
45)	Rajkot	41.1	22.2	40.0	22.0	38.9	22.6	27.9	33.4	27.4	32.2	27.0	31.3	11.9	13.4
46)	Ramagundam	43.4	25.6	42.2	25.1	40.7	25.8	28.3	37.3	27.9	35.6	27.4	34.4	12.5	13.7
47)	Ranchi	38.9	22.1	37.7	21.8	36.4	21.5	26.2	31.7	25.6	30.4	25.2	29.2	9.1	10.4
48)	Ratnagiri	34.1	22.8	33.3	23.2	32.7	23.5	27.2	30.6	27.0	30.3	26.7	29.9	18.2	19.2
49)	Raxaul	38.6	23.1	36.9	24.5	35.5	24.6	28.9	33.0	28.4	32.0	28.1	31.8	7.5	8.5
50)	Saharanpur	41.3	23.8	39.6	24.6	38.1	24.0	28.5	33.6	28.1	32.9	27.8	32.5	1.7	3.0
51)	Shillong	24.2	19.7	23.5	19.4	22.8	18.9	20.7	23.3	20.3	22.7	19.9	22.2	-1.0	0.1
52)	Sholapur	41.1	22.2	40.1	22.5	39.0	22.3	26.6	33.1	25.9	32.1	25.4	31.4	15.9	17.1
53)	Surat	37.8	22.5	36.4	22.9	35.2	23.1	28.1	31.9	27.7	31.4	27.4	31.1	14.4	15.6
54)	Sundernagar	36.1	19.1	34.6	19.6	33.1	19.4	25.2	30.1	24.8	29.2	24.4	28.0	1.8	2.8
55)	Tezpur	34.2	27.4	33.3	26.5	32.5	27.1	28.9	32.8	28.4	31.8	28.0	31.4	10.5	11.4
56)	Thiruvananthapuram	33.8	25.8	33.2	25.7	32.8	25.6	27.6	31.7	27.2	31.2	26.9	30.8	22.1	22.7
57)	Tiruchchirapalli	39.0	25.8	38.1	25.7	37.3	25.5	27.8	35.0	27.2	34.1	26.9	33.5	20.0	20.8
58)	Varanasi	43.0	22.5	41.8	22.7	40.1	23.2	28.9	33.8	28.6	33.2	28.2	32.6	7.8	8.9
59)	Veraval	34.8	23.6	33.7	25.5	33.0	26.3	29.3	32.1	29.0	31.7	28.6	31.3	15.0	16.2
60)	Visakhapatnam	33.7	27.0	32.9	27.5	32.3	27.3	29.1	32.0	28.7	31.6	28.3	31.2	20.1	20.8

NOTE — Abbreviations used:
 DB — Dry-bulb temperature.
 WB — Wet-bulb temperature.
 MCDB — Mean coincidental dry-bulb temperature.
 MCWB — Mean coincidental wet-bulb temperature.

definition clearly highlights the importance of both the psychological (mental) and physiological (physical) factors in determining acceptable thermal comfort conditions. The following four environmental parameters are important while designing the HVAC system because these are directly controllable by an HVAC system:

- a) Air temperature (°C),
- b) Radiant temperature (°C),
- c) Air speed (m/s), and
- d) Relative humidity (percent).

In addition to the above four environmental parameters, there are two personal or behavioural parameters that also affect thermal comfort but are not controllable by the HVAC system and they are as follows:

- 1) Activity rate (W/m²), and
- 2) Clothing insulation (m².K/W).

There are number of secondary parameters also which are important to define thermal comfort conditions such as, radiative temperature asymmetry, temperature gradient, and draught rate.

6.2 Design of Indoor Conditions as per Adaptive Thermal Comfort Model

Air conditioning systems for interior spaces intended for human occupancy shall be sized for not more than 26°C for cooling and for not less than 18°C for heating at occupied level.

Design based on an adaptive thermal comfort model can play a major role in reducing energy use whilst maintaining the comfort, productivity and well-being of occupants. This approach recognizes that people's thermal comfort needs depend on their past and present context and that these needs vary with the outdoor environmental conditions of their location. People living year-round in air conditioned spaces are likely to develop high expectations for homogeneity and cool temperatures, and may become quite critical if thermal conditions deviate from the centre of the comfort zone they have come to expect. In contrast, people who live or work in naturally ventilated buildings, are able to control their immediate interior spaces, get accustomed to variable indoor thermal conditions that reflect local patterns of daily and seasonal climate changes. Their thermal perceptions, preferences as well as tolerances are likely to extend over a wider range of temperatures. It allows buildings to operate within broader temperature bands. The specification of a broader comfort band suited to the Indian context has the potential to reduce the use of energy intensive space cooling for buildings in India.

This Section deals with adaptive thermal comfort model

which differentiates the thermal response of occupants in air conditioned and naturally ventilated buildings. It is imperative to specify indoor comfort conditions separately for buildings depending upon their operation, namely, air conditioned buildings as well as naturally ventilated buildings.

Operative temperature is more suitable index to measure thermal comfort in the building having low indoor air velocities, since the index also accounts for impact of building surface temperatures (radiant temperatures) on human comfort. Indoor operative temperature, for sedentary activities, can be approximated as an arithmetic mean of indoor air and radiant temperatures. For operating air conditioning system based on operative temperature, the prevalent conditions along with the historical outdoor trend can be used to derive suitable operative temperature limits. Typical climatic conditions of various Indian cities is in public domain.

In case of buildings having higher indoor air velocity (more than 0.5 m/s), effective temperature based approach is recommended since in addition to all factors considered in operative temperature, it also takes into account heat dissipation from human body through convective heat transfer. High air velocity can give opportunity of keeping higher air temperature without compromising thermal comfort. However, it is also suggested to keep under consideration noise and other effect of high indoor air velocity. For annual indoor design conditions as per adaptive model, for Indian cities, reference may be made to Annex A. These are indicative simplified values. They have been derived using typical weather files. It is recommended to practice sector specific adaptive thermal comfort model. More accurate design conditions can be derived using following equations. These equations are not applicable for outdoor running mean temperatures below 15°C.

a) *For naturally ventilated (NV) buildings:*

The following equation should be used for design and operation of naturally ventilated (NV) buildings. It indicates that occupants in NV buildings thermally adapt to the outdoor temperature of their location. It is based on the 30 day outdoor running mean temperature (in °C).

$$\text{Indoor operative temperature} = (0.54 \times \text{outdoor temperature}) + 12.83$$

Where, indoor operative temperature (in °C) is neutral temperature, and outdoor temperature is the 30 day outdoor running mean air temperature (in °C).

The 90 percent acceptability range for the India specific adaptive models for naturally ventilated buildings is $\pm 2.38^\circ\text{C}$.

b) *For mixed-mode (MM) buildings:*

Mixed-mode buildings, where HVAC is operated only during extreme outdoor conditions, are becoming prevalent in India. The occupants in mixed-mode buildings are more adaptive when compared to those in air conditioned buildings and somewhat less adaptive compared to occupants in naturally ventilated buildings.

$$\text{Indoor operative temperature} = (0.28 \times \text{outdoor temperature}) + 17.87$$

Where indoor operative temperature (in °C) is neutral temperature and outdoor temperature is the 30 day outdoor running mean air temperature (in °C).

The 90 percent acceptability range for the India specific adaptive models for mixed-mode buildings is $\pm 3.46^\circ\text{C}$.

c) *For air conditioned (AC) buildings:*

Studies shows that static Predictive Mean Vote (PMV) model over-predicts the sensation on the warmer side of the 7 point sensation scale in air conditioned buildings. One of the two methods should be adopted while determining indoor conditions of fully air conditioned buildings. One of these methods is based on air temperature and the other is based on standard effective temperature (SET) which includes effect of body surface area, relative humidity (RH), air velocity (V_a), air temperature (T_a), radiant temperature (T_r), outdoor temperature (T_{out}), clothing insulation (Clo) and activity rate (MET).

1) *Air temperature based approach:*

$$\text{Indoor operative temperature} = (0.078 \times \text{outdoor temperature}) + 23.25$$

Where indoor operative temperature (in °C) is neutral temperature and outdoor temperature is the 30 day outdoor running mean air temperature (in °C).

The 90 percent acceptability range for the adaptive models for conditioned buildings is $\pm 1.5^\circ\text{C}$.

2) *Standard effective temperature based approach:*

$$\text{Standard effective temperature} = (0.014 \times \text{outdoor temperature}) + 24.53$$

Where standard effective temperature (in °C) is neutral temperature and outdoor temperature is the 30 day outdoor running mean air temperature (in °C).

The 90 percent acceptability range for the adaptive models for conditioned buildings is $\pm 1.0^\circ\text{C}$.

3) *Minimum outside fresh air:*

Table 3 prescribes minimum supply rates of

acceptable outdoor air required for acceptable indoor air quality. These requirements for ventilation of health care facilities (hospitals, nursing and convalescent homes) are separately covered in Table 4. These values have been prescribed to dilute human bio effluents and other contaminants with an adequate margin of safety and to account for health variations among people and varied activity levels. The values prescribed in the table shall be used in conjunction with the accompanying notes.

Naturally ventilated spaces and mixed mode spaces, while getting operated in naturally ventilated mode, will have to rely on outdoor air using fenestration systems. The quantity and distribution of introduced fresh air should take into account the natural infiltration of the building.

The proportion of fresh air introduced into air conditioned building may be varied to achieve economical and efficient operation. When the fresh air can provide a useful cooling effect, the quantity shall be controlled through air side economizer to balance the cooling demand. However, when the air is too warm or humid the quantity may be reduced to a minimum to reduce the cooling load.

6.3 Indoor Air Quality (IAQ)

Indoor air quality is the quality of air which affects our comfort and health. This is most directly related to health and may result in sick building syndrome (SBS). Poor indoor air quality results in severe and recurring discomforts such as nausea, headaches, cold, dry mucous, inflamed membrane eye, nose and throat irritation, drowsiness, fatigue, dry skin and respiration problems.

6.3.1 Measure of Indoor Air Quality (IAQ)

Carbon dioxide is used as a surrogate ventilation index for diagnosing the ventilation efficiency in an air conditioned area. The measurement of carbon dioxide inside a conditioned area is an indicator of IAQ. Odour criteria are likely to satisfy, if ventilation rates are set so that 1 000 ppm CO_2 is not exceeded. However, in situations where outdoor conditions are not favourable, a difference of 700 ppm, where indoor ppm are less than outdoors, should be targeted. Building should meet accepted standards to avoid contamination through volatile organic compounds, microbial contamination (fungal and bacteria).

6.3.2 Components of Acceptable Indoor Air Quality (IAQ)

Acceptable IAQ is typically not achieved by addressing any one specific building product, system or procedure;

Table 3 Minimum Ventilation Rates in Breathing Zone (See Notes 1 to 5)

[Clause 6.2(c)(3)]

(This table is not valid in isolation; it shall be used in conjunction with the accompanying notes.)

Sl No.	Occupancy Category	People Outdoor Air Rate, R_p		Area Outdoor Air Rate, R_a		Notes	Default Values			Air ¹⁾ Class
							Occupant Density (see Note 4)	Combined Outdoor Air Rate (see Note 4)		
		cfm/person	l/s. person	cfm/ft ²	l/s.m ²			Persons per 1 000 ft ² or per 100 m ²	cfm/person	
(1)	(2)	(3)	(4)	(5)	(6)	(7)	(8)	(9)	(10)	(11)
i)	Correctional facilities:									
	a) Cell	5	2.5	0.12	0.6		25	10	4.9	2
	b) Dayroom	5	2.5	0.06	0.3		30	7	3.5	1
	c) Guard Stations	5	2.5	0.06	0.3		15	9	4.5	1
	d) Booking/waiting	7.5	3.8	0.06	0.3		50	9	4.4	2
ii)	Educational facilities:									
	a) Daycare (through age 4)	10	5	0.18	0.9		25	17	8.6	2
	b) Daycare sickroom	10	5	0.18	0.9		25	17	8.6	3
	c) Classrooms (ages 5-8)	10	5	0.12	0.6		25	15	7.4	1
	d) Classrooms (age 9 plus)	10	5	0.12	0.6		35	13	6.7	1
	e) Lecture classroom	7.5	3.8	0.06	0.3		65	8	4.3	1
	f) Lecture hall (fixed seats)	7.5	3.8	0.06	0.3		150	8	4.0	1
	g) Art classroom	10	5	0.18	0.9		20	19	9.5	2
	h) Science laboratories	10	5	0.18	0.9		25	17	8.6	2
	j) University/college laboratories	10	5	0.18	0.9		25	17	8.6	2
	k) Wood/metal shop	10	5	0.18	0.9		20	19	9.5	2
	m) Computer lab	10	5	0.12	0.6		25	15	7.4	1
	n) Media centre	10	5	0.12	0.6	See Note 6	25	15	7.4	1
	p) Music/theatre/dance	10	5	0.06	0.3		35	12	5.9	1
	q) Multi-use assembly	7.5	3.8	0.06	0.3		100	8	4.1	1
iii)	Food and beverage service:									
	a) Restaurant dining rooms	7.5	3.8	0.18	0.9		70	10	5.1	2
	b) Cafeteria/fast-food dining	7.5	3.8	0.18	0.9		100	9	4.7	2
	c) Bars, cocktail lounges	7.5	3.8	0.18	0.9		100	9	4.7	2
iv)	General:									
	a) Break rooms	5	2.5	0.06	0.3		25	10	5.1	1
	b) Coffee stations	5	2.5	0.06	0.3		20	11	5.5	1
	c) Conference/meeting	5	2.5	0.06	0.3		50	6	3.1	1
	d) Corridors	—	—	0.06	0.3		—	—	—	1
	e) Storage rooms	—	—	0.12	0.6	See Note 7	—	—	—	1
v)	Hotels, motels, resorts, dormitories:									
	a) Bedroom/living room	5	2.5	0.06	0.3		10	11	5.5	1
	b) Barracks sleeping areas	5	2.5	0.06	0.3		20	8	4.0	1
	c) Laundry rooms, central	5	2.5	0.12	0.6		10	17	8.5	2
	d) Laundry rooms within dwelling units	5	2.5	0.12	0.6		10	17	8.5	1
	e) Lobbies/prefunction	7.5	3.8	0.06	0.3		30	10	4.8	1
	f) Multipurpose assembly	5	2.5	0.06	0.3		120	6	2.8	1
vi)	Office buildings:									
	a) Office space	5	2.5	0.06	0.3		5	17	8.5	1
	b) Reception Areas	5	2.5	0.06	0.3		30	7	3.5	1
	c) Telephone/data entry	5	2.5	0.06	0.3		60	6	3.0	1
	d) Main entry lobbies	5	2.5	0.06	0.3		10	11	5.5	1
vii)	Miscellaneous spaces:									
	a) Bank vaults/safe deposit	5	2.5	0.06	0.3		5	17	8.5	2
	b) Computer (not printing)	5	2.5	0.06	0.3		4	20	10.0	1
	c) Electrical equipment rooms	—	—	0.06	0.3	See Note 7	—	—	—	1
	d) Elevator machine rooms	—	—	0.12	0.6	See Note 7	—	—	—	1
	e) Pharmacy (preparation area)	5	2.5	0.18	0.9		10	23	11.5	2
	f) Photo studios	5	2.5	0.12	0.6		10	17	8.5	1
	g) Shipping/receiving	—	—	0.12	0.6	See Note 7	—	—	—	1
	h) Telephone closets	—	—	0.00	0.0		—	—	—	1
	j) Transportation waiting	7.5	3.8	0.06	0.3		100	8	4.1	1
	k) Warehouses	—	—	0.06	0.3	See Note 7	—	—	—	2

Table 3 — (Concluded)

(1)	(2)	(3)	(4)	(5)	(6)	(7)	(8)	(9)	(10)	(11)
viii)	Public assembly spaces:									
a)	Auditorium seating area	5	2.5	0.06	0.3		150	5	2.7	1
b)	Places of religious worship	5	2.5	0.06	0.3		120	6	2.8	1
c)	Courtrooms	5	2.5	0.06	0.3		70	6	2.9	1
d)	Legislative chambers	5	2.5	0.06	0.3		50	6	3.1	1
e)	Libraries	5	2.5	0.12	0.6		10	17	8.5	1
f)	Lobbies	5	2.5	0.06	0.3		150	5	2.7	1
g)	Museums (children's)	7.5	3.8	0.12	0.6		40	11	5.3	1
h)	Museums/galleries	7.5	3.8	0.06	0.3		40	9	4.6	1
ix)	Residential:									
a)	Dwelling unit	5	2.5	0.06	0.3	See Notes 8 and 9	See Note 8	—	—	1
b)	Common corridors	—	—	0.06	0.3	—	—	—	—	1
x)	Retail:									
a)	Sales (except as below)	7.5	3.8	0.12	0.6		15	16	7.8	2
b)	Mall common areas	7.5	3.8	0.06	0.3		40	9	4.6	1
c)	Barbershop	7.5	3.8	0.06	0.3		25	10	5.0	2
d)	Beauty and nail salons	20	10	0.12	0.6		25	25	12.4	2
e)	Pet shops (animal areas)	7.5	3.8	0.18	0.9		10	26	12.8	2
f)	Supermarket	7.5	3.8	0.06	0.3		8	15	7.6	1
g)	Coin-operated laundries	7.5	3.8	0.06	0.3		20	11	5.3	2
xi)	Sports and entertainment:									
a)	Sports arena (play area)	—	—	0.30	1.5	See Note 10	—	—	—	1
b)	Gym, stadium (play area)	—	—	0.30	1.5	—	30	—	—	2
c)	Spectator areas	7.5	3.8	0.06	0.3	—	150	8	4.0	1
d)	Swimming (pool and deck)	—	—	0.48	2.4	See Note 11	—	—	—	2
e)	Disco/dance floors	20	10	0.06	0.3	—	100	21	10.3	1
f)	Health club/aerobics room	20	10	0.06	0.3	—	40	22	10.8	2
g)	Health club/weight rooms	20	10	0.06	0.3	—	10	26	13.0	2
h)	Bowling alley (seating)	10	5	0.12	0.6	—	40	13	6.5	1
j)	Gambling casinos	7.5	3.8	0.18	0.9	—	120	9	4.6	1
k)	Game arcades	7.5	3.8	0.18	0.9	—	20	17	8.3	1
m)	Stages, studios	10	5	0.06	0.3	See Note 12	70	11	5.4	1

1)	Air Class	Characteristic
1	Air with low contaminant concentration, low sensory-irritation intensity, and inoffensive odour.	
2	Air with moderate contaminant concentration, mild sensory-irritation intensity, or mildly offensive odours. Class 2 air also includes air that is not necessarily harmful or objectionable but that is inappropriate for transfer or recirculation to spaces used for different purposes.	
3	Air with significant contaminant concentration, significant sensory-irritation intensity, or offensive odour.	
4	Air with highly objectionable fumes or gases or with potentially dangerous particles, bio aerosols, or gases, at concentrations high enough to be considered harmful.	

NOTES

- 1 The rates in this table are based on all other applicable requirements being met.
- 2 This table applies to no-smoking areas only. Rates for smoking-permitted spaces shall be determined using other methods.
- 3 Volumetric airflow rates are based on an air density of 1.2 kgDA/m³, which corresponds to dry air at a barometric pressure of 1 atm (101.3 kPa) and an air temperature of 21°C. Rates may be adjusted for actual density but such adjustment is not required for compliance with this standard.
- 4 Actual occupant density should be considered, the default occupant density shall be used only when actual occupant density is not known. Default combined outdoor air (per person) rate is based on the default occupant density.
- 5 If the occupancy category for a proposed space or zone is not listed, the requirements for the listed occupancy category that is most similar in terms of occupant density, activities and building construction shall be used.
- 6 For high school and college libraries, use values shown for public assembly spaces- libraries.
- 7 The prescribed value may not be sufficient when stored materials include those having potentially harmful emissions.
- 8 Default occupancy for dwelling units shall be two persons for studio and one-bedroom units, with one additional person for each additional bedroom.
- 9 Air from one residential dwelling shall not be recirculated or transferred to any other space outside of that dwelling.
- 10 When combustion equipment is intended to be used on the playing surface, additional dilution ventilation and/or source control shall be provided.
- 11 The prescribed value does not allow for humidity control. Additional ventilation or dehumidification may be required to remove moisture.
- 12 The prescribed value does not include special exhaust for stage effects, for example, dry ice vapours, smoke.

Table 4 Outdoor Air Requirements for Ventilation of Health Care Facilities
[Clause 6.2(c)(3)]

Sl No.	Application	Estimated Maximum Occupancy ¹⁾ Persons/100 m ²	Outdoor Air Requirements		Remarks
			l/s per Person	l/s per m ²	
(1)	(2)	(3)	(4)	(5)	(6)
i)	Patient rooms	10	13	—	Special requirements and pressure relationships may determine minimum ventilation rates and filter efficiency. Procedures generating contaminants may require higher rates Air shall not be recirculated into other spaces
ii)	Medical procedure	20	8	—	
iii)	Operating rooms	20	15	—	
iv)	Recovery and ICU	20	8	—	
v)	Autopsy rooms	20	—	2.5	
vi)	Physical therapy	20	8	—	

¹⁾ Net occupiable space.

rather, it is the result of careful attention to each of the following fundamental elements:

- a) Contamination source control;
- b) Proper ventilation;
- c) Humidity management; and
- d) Adequate filtration.

Controlling the source of contaminants is fundamental to any IAQ strategy. Indoor contamination can also be in the form of particles or chemicals that may come from occupants and their activities. Contaminants from stationary local sources within the space should be controlled by collection as close to the source as practical and its removal from there itself. In some cases such as volatile organic compounds (VOCs), where collection close to sources is not possible, dilution with clean outdoor air should be adopted as the most practical and cost effective solution.

Microbial contamination (fungi and bacteria) can also be a major source of indoor contamination. When mold spores and other microbiological particles become airborne, occupants may experience allergic reactions; these result in offensive odours within the building. Proper design and selection of the air conditioning system should prevent the issues related to microbial contamination. Indoor humidity levels over 60 percent RH for periods as short as 24 h can support the growth of some forms of mold and fungi and should therefore be avoided.

6.3.3 Subject to be managed at Contamination Source

These should be managed by separate management system, as follows:

- a) Depending upon size and capacity of photocopying machines, ammonia-printing machines, local exhaust system should be used to exhaust from such equipment.
- b) Fibrous insulating material should not be used

for internal lining and thermal insulation of ducts in health care facilities and food industries. For all other applications, it may be used with factory lamination back-up or suitable jacketing to avoid loose fibres getting into air stream.

- c) Formaldehyde from reconstituted wood and other lingo-cellulosic products: Use of alternative materials may be considered.

6.3.4 Subject to be Managed at Operation and Maintenance Stage

- a) It shall be ensured that the chilled water temperature is adequate or the refrigerant charge is adequate in the case of DX system. High humidity inside the conditioned area shall be avoided through proper dehumidification.
- b) Mildew and mold spores from the damp corners or on false ceiling, damp carpeting and office furniture where there is water leakage from the air-conditioning units: it shall be ensured that there is no leakage from the drain pan of the units or no condensation on the chilled water/refrigerant pipes and valves by properly insulating the same.
- c) Generation of fumes inside the conditioned area: ionizers shall be used.
- d) Air handling unit rooms shall not be used as a storage space for storing files and waste materials.
- e) Dirty supply air ducts, dirty false ceiling and return air space, dirty filters, dirty water accumulation or standing water in the drain pans, dirty cooling coils, dirty water in the air coolers and evaporative cooling plants, virus, bacteria, fungus from the air handling unit and drain pan of the air handling units, etc: Planned

operation and preventive maintenance shall be implemented to avoid such issues.

6.3.5 Pre-Occupancy Purge of Contamination

Pre-occupancy purge shall be carried out to ensure that contaminants, that may build up during construction or during unoccupied periods, are removed prior to occupancy.

7 DESIGN OF AIR CONDITIONING

7.1 General

Systems for air conditioning need to control temperature, humidity and air quality within predetermined limits throughout the year. Systems for air conditioning may be grouped as all-air type, air and water type, all-water type and unitary type. Suitability of system type cannot be generalized; it needs to be building specific decision considering, initial cost, efficiency, maintenance, effect on building aesthetics, noise, service life and other factors. Lower operating cost, central maintenance and control are primary considerations. Designers may select centralized systems that comprise DX units or chillers and cooling towers (as applicable), all housed away from occupied spaces. This mitigates noise impacts. The heating application may require heat pumps or boilers.

These systems often require a greater initial cost than distributed systems but often result in annual energy savings because additional benefits also include the ability to reduce installed capacity by using load diversity. Centralized cooling systems usually prove to be more cost-effective when the total building load exceeds 100 TR, depending on climate and patterns of occupancy use. Central heating systems are desirable in heating applications in many building sizes since they can provide closer space control and can be used with many types of terminal units.

When low initial cost and simplicity are primary concerns, designers may select zone-by-zone distributed systems, incorporating either cooling or both heating and cooling facility. This approach tends to be used for smaller buildings as well as for larger buildings with multiple tenancy and sufficient roof area. Distributed equipment consists of fan, cooling coil, compressor and outdoor condenser. Examples of distributed systems include unitary air conditioners, packaged rooftop air conditioners, variable refrigerant flows (VRFs), heat pumps, as well as refrigerant-based split-system fan-coil units (single or multi-unit). Water-source heat pumps (WSHPs) are also distributed systems in which the compressor is located close to the occupied space, but they are collectively served by a centralized water system with auxiliary heat rejection devices.

7.2 Design Considerations

7.2.1 System Analysis and Selection

System selection for occupant comfort, as defined in 6, for space cooling, heating and ventilation, shall be based on the following criteria:

- 1) Temperature and its acceptable variation,
- 2) Humidity and its acceptable variation,
- 3) Air movement,
- 4) Air purity or quality,
- 5) Air changes per hour,
- 6) Air and/or water velocity requirements,
- 7) Local climate,
- 8) Space pressure requirements,
- 9) Capacity requirements as per load calculation analysis,
- 10) Redundancy,
- 11) Spatial requirements,
- 12) Fire safety and security concerns,
- 13) Initial cost,
- 14) Operating cost, including energy and power costs,
- 15) Maintenance cost,
- 16) Reliability,
- 17) Flexibility,
- 18) Controllability,
- 19) Life-cycle analysis,
- 20) Sustainability characteristics,
- 21) Acoustics and vibration, and
- 22) Mold and mildew prevention.

7.2.1.1 Types of systems

Comparative advantages, disadvantages and constraints of each option should be carefully evaluated before zeroing down to final HVAC system selection. Table 5 lists out various system characteristics of different HVAC systems; the same may be used as a tool for system analysis and selection.

When accurate temperature control is needed, constant volume systems shall be used. Dehumidification arrangement and return air bye-pass shall be included while designing constant volume system. When using high velocity system, dual ducting shall be provided.

7.2.2 The requirements for various air conditioning equipment/system are given in 7.2.3 to 7.2.15.

7.2.3 Central Chilled Water System — Types and Components

7.2.3.1 The central chilled water system equipment selection criteria shall be based on a comprehensive study to evaluate and define the lowest life-cycle cost

Table 5 HVAC System Analysis and Selection Matrix
(Clause 7.2.1.1)

SI No.	System Characteristic	Fixed Speed Unitary Systems (Window ACs/Split ACs/ Package ACs)	Variable Speed/Flow/ Frequency/ Capacity Unitary Systems (Inverter Split ACs/Package ACs)	Variable Speed Multi or Modular Systems (VRF)	Central Systems
(1)	(2)	(3)	(4)	(5)	(6)
i)	Temperature	No uniform and effective control	Minimal uniform and effective control possible	Reasonably uniform and effective control possible	Uniform and effective control possible
ii)	Relative humidity	Effective control not possible	Effective control not possible	Effective control not possible	Effective control possible
iii)	Space pressure	Effective control not possible	Effective control not possible	Effective control not possible	Effective control possible
iv)	Capacity requirements	Capacity to suit zone peak, no diversity	Capacity to suit zone peak, no diversity	Capacity to suit zone peak, limited diversity can be considered	Allows the design engineer to consider HVAC load diversity factors, accordingly reduce installed equipment capacity
v)	Redundancy	Does not have the benefit of back-up or standby equipment	Does not have the benefit of back-up or standby equipment	It has the benefit of partial back-up or standby equipment	Back-up or standby equipment can easily be accommodated
vi)	Facility management	Allows minimal provision to maximize performance using good facility management techniques in operation	Allows minimal provision to maximize performance using good facility management techniques in operation	Limited possibilities to maximize performance using good facility management techniques in operation	Allows to maximize performance using good facility management techniques in operation
vii)	Spatial requirements	No plant/equipment room required. Compromises building elevation	No plant/equipment room required. Compromises building elevation	No plant/equipment room required. Outside units can be located on roof or on adjacent ground. Very small shaft desirable for refrigerant piping	Equipment rooms/spaces and accessible shaft required for chilled water piping
viii)	Electric supply	Distributed electric supply required	Distributed electric supply required	Zone-wise distributed electric supply required	Minimal distribution cost by centralized supply near the substation
ix)	Initial cost	Minimum initial cost	Initial cost marginally higher than fixed speed system	Moderate initial cost but marginally higher than variable speed unitary product	Even with HVAC diversity, a central system may not be less costly than decentralized HVAC systems
x)	Operating cost	Higher operating cost. Strategic scheduling of multiple pieces of equipment can save marginal operating cost, but equipment is less efficient	Strategic scheduling of multiple pieces of equipment can save reasonable operating cost, but higher peak energy requirement	Strategic scheduling of equipment can save operating cost better than unitary product, but higher peak energy requirement	More energy-efficient primary equipment and multiple pieces of HVAC equipment allow staging of operation to match building loads while maximizing operational efficiency
xi)	Maintenance cost	Comparatively less maintenance cost	Maintenance cost marginally higher than fixed speed	Maintenance cost higher than both fixed and variable speed unitary system but less than central system	Comparatively higher since centralized equipment room requires operator with no access to occupant workspace, but with fewer pieces of HVAC equipment to service
xii)	Reliability	Reliable equipment but low service life	Reliable equipment but low service life	Reliable equipment but moderate service life	Reliable equipment with much longer service life
xiii)	Flexibility	Has to be placed at fixed locations	Has to be placed at fixed locations	Can be placed at distributed locations	Flexibility available in terms of alternative locations
xiv)	Level of control	Limited control level available	Limited control level available	Moderate control level available	Close control level available
xv)	Noise and vibration	Noise and vibration within/adjacent to occupied spaces for unitary window type air conditioners which is substantially reduced in case of split system	It is generally available in split system only for which noise and vibration is substantially reduced in occupied and adjacent spaces as compared to a window type air conditioner	Noise and vibration on roof terrace or ground, away from occupied spaces; however the same can be reduced with good installation practices	Noise and vibration away from occupied spaces
xvi)	Constructability	Multiple and similar-in-size equipment makes standardization a construction feature	Multiple and similar-in-size equipment makes standardization a construction feature	Multiple and similar equipment makes standardization a construction feature	Require more coordinated installation with added benefit of consolidated primary equipment in a central location

of the chilled water system. The study shall address system components and parameters, such as, chilled water leaving temperature, condenser water entering temperature, inlet/outlet chilled water and condenser water temperature differential, chilled/condenser water flow, pipe and pump sizes, etc.

While optimizing the chilled water system parameters, special consideration shall be given to the spaces requirements as given hereunder:

- a) Space for chillers, pumps, and cooling towers should not only include installation footprints but should also account for adequate clearances to perform routine and major maintenance. A service clearance of 1.2 m or the manufacturer's recommended minimum clearance for the equipment, whichever is greater, shall be provided around equipment for operation, maintenance and service. For chillers, one end of the chiller barrels should be provided with free space, equivalent to the length of the evaporator and condenser barrels, to allow for tube pull-out. Designer may consider service bay roll-up doors or ventilation louvers for this tube access. Overhead service clearance height is also required, especially where chillers are installed. Where boiler installations as well as heating distribution equipment and appurtenances are required, the plant's physical size shall account for the type of boiler and the required exhaust emissions treatment. Good architectural planning requires that the location of all outdoor air intakes is kept preferably on opposite sides of exhaust and possible as far away as from contaminating sources like the exhaust outlets, loading docks and others. The final mechanical room size, orientation, and location shall be established after discussion with the architect and owner. The design engineer should keep the architect, owner, and facility engineer informed about the HVAC load analysis and system selection.
- b) Winter time cooling requirement for applications like operating rooms, conference halls, high population density spaces like banquet halls and others, shall also be evaluated before finalizing system/equipment design.
- c) All systems should be coordinated during the space-planning stage for safe and effective operation and maintenance of the central cooling and heating plant.
- d) Large commercial developments, residential

complexes and mixed use development projects generally provide a single central chilled water plant to serve multiple buildings. This allows the plant size to be reduced by taking into account diversity in loads for these buildings. The central plant for these applications should, generally, be placed on grade in an independent utility services block, which also houses most of the other high-side equipment like HT panel, transformers, DG sets, main LT panel, water storage tanks, water treatment plants, water supply pumps, fire water storage tanks, fire pumps and others.

- e) Central plant catering to an individual building should, generally, be housed on the lowest basement floor slab resting on terra-firma. This inherently isolates noise and vibration transmission to the super-structure. However, the designer shall always ensure easy access for maintenance and replacement of the major components of the central plant.

The choice of refrigerant shall be based on guidelines specified in 3.

7.2.3.2 Central chilled water plant sizing

The refrigeration/cooling plant size shall be optimized considering block load of the project, and the module selection shall be based on the optimal performance of chillers. However, the ancillary equipment like pumps, cooling tower, terminal units and other components shall be sized for the entire load profile of the project. The cooling load requirements for special applications where mandated dedicated chillers may be required, shall be met through full redundancy.

7.2.3.3 Standby chiller capacity

For new construction and major renovation projects, the central chilled water plant shall comprise number of chillers in operation to meet the total cooling demand. Only in critical operation projects, one standby chiller, equivalent to the largest capacity chiller, should be installed to provide 100 percent standby. However, in most of the commercial and residential projects, full load is encountered less than five percent of the time throughout the year; therefore, three chillers each of 40 percent of full load capacity, may generally be installed to provide part standby chiller capacity.

All other system components, namely, chilled water pumps, condenser water pumps, cooling towers and controls shall be sized and selected to match the installed chiller capacity including the standby machine.

7.2.3.4 Liquid chilling machines

Liquid chilling system may be based on chilled water,

brine, or other secondary coolant for air conditioning or refrigeration. The most frequent application is water chilling for air conditioning, however, brine cooling for low temperature refrigeration and chilling fluids for thermal storage processes, are also becoming common.

The basic components of a vapour compression, liquid chilling system include a compressor, liquid cooler (evaporator), condenser, compressor drive, liquid refrigerant expansion or flow control device and control center; it may also include a receiver, economizer, expansion turbine and/or sub-cooler (*see 7.2.3.5* for vapour compression water chiller). In addition, auxiliary components may be used, such as a lubricant cooler, lubricant separator, lubricant-return device, purge unit, lubricant pump, refrigerant transfer unit, refrigerant vents, and/or additional control valves. Liquid chilling units are also available with air cooled condensers.

7.2.3.5 Vapour compression water chiller

The unit shall be set down on to a solid foundation on resilient mountings. Pipe connections shall have flexible couplings; these should be considered in conjunction with the design of the pump mountings and the pipe supports.

Capacity control shall be capable to maintain an approximately constant temperature of the chilled water leaving the evaporator. This may be adequate for one or two chiller packages, but a more elaborate central control and plant optimization system is desirable for a large number of chillers. The design of the refrigeration control system should be integrated, or be compatible, with the control system for the heat transfer medium circulated within the cooler.

Multiple chiller configuration, same or different size and types shall be used to achieve the highest energy efficiency, and adequate system capacity availability at all conditions. System COP shall be the basis for design and selection of equipment.

Power consumption during operation should be reduced by taking advantage of a fall in the ambient dry-bulb and wet-bulb temperatures, which permit a corresponding increase in chilled water temperature and decrease in the condenser water temperature, and consequent considerable reduction in the compressor power consumption. It is important to optimize operating cost by optimum equipment selection and careful design of the automatic control system.

The water chilling packages are classified based on the type of compressor, as given below:

- a) *Centrifugal compressor* — These compressors use impellers to impart pressure energy to the refrigerant. These may be modulated down to approximately 40 percent of full load capacity,

with careful control of the condensing pressure. Part load operation of centrifugal compressor should be restricted to 40 percent or above in order to avoid surging of compressor that may damage it if continues to occur.

In order to save energy, centrifugal compressors with variable speed drives (VFDs) should be preferred over fixed speed chillers. VFDs are used on chillers not only to enhance the part load performance but also to act as an alternate to auto-tap change starter for minimising the starting current for the compressor.

Modern variable-speed oil-free centrifugal chillers have the shaft with impeller levitated during rotation, using digitally-controlled magnetic bearings. This unique feature reduces the friction and heat caused by conventional bearings, adding to the overall high efficiency. It also eliminates the need for lubricating oil and the ancillary components required to support the lubricating oil system, which further improves efficiency.

- b) *Screw compressor* — Screw compressors are available in open and semi-hermetic form and are generally coupled directly to two-pole motors. The capacity of the compressor may be modulated down to 20 percent of full load capacity.

Similar to centrifugal compressors, screw compressors with VFDs may be used as an effective way to enhance the part load performance and also minimise the starting current for the compressor.

These are generally specified and used for capacities up to 400TR.

In systems using a direct expansion evaporator (DX chiller), the oil is trapped in the evaporator and an oil recovery system is necessary.

With some systems, oil cooler is required in the oil circulation system, to remove the heat gathered by oil during compression cycle.

- c) *Scroll compressor* — Scroll compressors are generally used in residential and small/light commercial air-conditioning. Scroll chillers may be used in smaller sizes up to 120 TR.
- d) *Reciprocating compressor* — Due to their relatively lower efficiency, reciprocating compressors are nearly phased out from the comfort air-conditioning application. However, for cold storage and other special purpose applications, these still have importance due to their capacity to offer high pressure ratio.

7.2.3.6 Absorption System

The absorption cycle uses a solution which, by absorbing the refrigerant, replaces the function of the compressor. The absorbent/refrigerant mixture is then pumped to a higher pressure where the refrigerant is boiled off by the application of heat, and is subsequently condensed in the condenser.

Absorption machines are extensively used in liquid chilling applications. These are most suitable for applications where waste heat is readily available. Solar energy assisted air conditioning/cooling systems also use absorption systems.

7.2.3.6.1 Indirect firing

The lithium bromide/water absorption system can be powered by medium or high temperature hot water and low or medium pressure steam. Water is the refrigerant and lithium bromide, the absorbent. The four compartments enclosing the heat exchanger tube bundles for the condenser, evaporator, generator and absorber can be in a single or multiple pressure vessel arrangement. The whole assembly has to be maintained under a high vacuum, which is essential for the correct functioning of the unit. Water and absorbent solutions are circulated within the unit by electrically driven pumps.

Capacity control down to 10 percent of full load capacity is achieved by modulating the flow of the heating medium in relation to the cooling demand. There is some loss in performance at part load, which can be compensated by refinements in the system design and control.

7.2.3.6.2 Direct firing

Direct fired lithium bromide/water absorption plants have become common, by incorporating precise control of generator temperature necessary to avoid crystallization.

Ammonia/water systems are generally direct fired, but are rarely used for water chilling duties, except for small sized units, which are installed outside the building. There are two reasons for this; firstly capital costs are higher and secondly the danger to personnel in the event of leakage of the refrigerant.

Direct firing has the advantage that the losses in an indirect heating system are avoided, but in an air conditioning installation where a boiler system is installed to provide heating, the advantage is not of much concern.

7.2.3.7 Chilled water system components

7.2.3.7.1 Chilled and condenser water pumps

Radial flow centrifugal pumps are recommended for use in HVAC systems for circulation or transfer of water

or water/glycol solutions. The choices available are single inlet/end suction or double suction type pump. In the end suction pump, liquid enters through a single inlet with end suction to impeller, while in double suction pump liquid enters on two sides of the impeller along the shaft. Double suction pumps are inherently self-balancing with reduced impact on bearings and on mechanical seal, when fluid enters the pump. This may be preferred for larger flow (> 63 litre per second) requirement. Some smaller end-suction pumps are direct-coupled, where the impeller mounts directly on the shaft of a face-mounted motor. A third popular HVAC pump is the in-line centrifugal, in which inlet and discharge piping are in line. Direct coupled pump assembly and inline pump may be used for smaller flow applications. Higher flow rate requiring motor size above 7.5 kW, pumps shall be coupled with high efficiency (Eff1) motors. Mono-block pumps are generally used up to 7.5 kW, but are not yet available with motor having Eff1 efficiency.

The split case horizontal pump shall be used in larger applications. These pumps cost more than other pumps, but are more efficient. Split casing also allows inspection and maintenance without disturbing the rotor, motor, or the connecting piping.

Centrifugal (horizontal or vertical split-case or vertical turbine) pumps mounted on base, are generally provided for chilled water and condenser water applications. In-line pumps may also be used for certain applications to minimise plant room space requirement.

Cavitation shall be avoided by selecting suitable location of pump with respect to the cooling tower, so as to always meet the net positive suction head (NPSH) requirement of condenser water pump.

Selection criteria and types of pumping system — Pump shall be selected to operate at lowest possible rpm to achieve energy efficiency. The operating point shall be selected at or near the highest efficiency and to the left side of the maximum efficiency point but not more than 5 percent from the maximum efficiency curve. The pump motor shall be non-overloading over the entire range of its operation and compatible with variable speed drive, where such applications are used. For water pumps, available net positive suction head (NPSH) shall exceed required NPSH to avoid pump cavitation.

The possible types of chilled water recirculation pumps are as given below:

- a) Constant speed pumping system;
- b) Variable speed pumping system (VSPS):
 - 1) Parallel VSPS configuration,
 - 2) Zoned VSPS configuration, and
 - 3) Primary secondary tertiary pumping system (P-S-T); and

- c) Primary only variable speed pumping system (PVF).

In order to improve energy efficiency of larger systems, where pumping energy amounts to 5 percent to 9 percent of total energy consumption in a building, glass flake coatings for large size pumps may be considered, based on life cycle cost assessment as it reduces friction and improves efficiency.

Chilled water circulation system having pump motor larger than 3.7 kW rating are generally designed for variable fluid flow to offer large savings in operating cost.

7.2.3.8 Cooling tower

7.2.3.8.1 Water is commonly used as a heat transfer medium to remove heat from the refrigerant vapour in condenser. Cooling tower is used to dissipate the heat from the air conditioning system. The water consumption rate for a cooling tower system is less than 5 percent of that for a once-through system, making it the least expensive system to operate with purchased water supplies. Additionally, the amount of heated water discharged (blow down) is very small, so the ecological effect is greatly reduced. Cooling tower can cool condenser water to within 2 to 3°C of the ambient wet-bulb temperature. Therefore, water cooled system operates at a condenser temperature in excess of 20°C lower than the corresponding air cooled system, resulting in considerably improved efficiency and significantly reduced energy consumption.

7.2.3.8.2 Selection criteria

Location of the cooling tower is usually determined by one or more of the following:

- a) Architectural compatibility,
- b) Rigging limitations,
- c) Structural support requirements,
- d) Cost of bringing auxiliary services to the cooling tower, and
- e) Noise transmission, plume, and drift considerations.

These are best handled by proper site selection during the planning stage. Cooling tower shall be installed raised above the mounting surface by 450 - 1 250 mm to permit installation of pot strainer in condenser water line from cooling tower sump; also to provide easy drainage and maintenance of mounting surface as follows:

Minimum cooling tower efficiency shall be as follows:

- 1) 350 litre per minute/HP for 24×7 facilities, and
- 2) 300 litre per minute/HP for all others.

Cooling tower approach shall be as follows:

- i) < 2.0°C approach for 24×7 plants, and
- ii) < 3.0°C approach for all other applications.

Cooling tower accessories shall be project-specific and shall include such items as walking platform; stairs and ladder safety cage; bird screen; tower loading and supporting structure; and variable speed drive fan motor.

Cooling tower installation shall include installation of conductivity controller, flow meter on the makeup water line, overflow alarm and low level alarm.

7.2.3.8.3 Scale control

Water treatment is desirable to prevent scaling, corrosion, and biological fouling of the condenser and circulating system. Large system shall be provided with fixed continuous-feeding chemical treatment system in which chemicals, including acids for pH control, are diluted, blended and pumped into the condenser water system. Corrosion-resistant materials may be required for the treatment of system components that come in contact with these chemicals. In piping system design, provision for feeding the chemicals, blow down, drain, and on-line testing should be included. Treatment system design should incorporate main stream filtration without separate pumping system.

It is desirable that following methods are used to control scale formation:

- a) Limit the concentration of scale-forming minerals by controlling cycles of concentration, or by removing the minerals before they enter the system. A cycle of concentration is the ratio of makeup water rate to the sum of blow down and drift rate. The cycle of concentration can be monitored by calculating the ratio of chloride ion, which is highly soluble in the system water, to that in the makeup water. Making mechanical changes in the system, like increasing water flow and providing exchanger with larger surface area, reduce the chances of scale formation.
- b) Feed acid to keep the common scale forming minerals, like, calcium carbonate, in dissolved state.
- c) Treat with chemicals designed to prevent scale.

For treatment of water for cooling towers, reference shall be made to the good practice [8-3(3)].

7.2.3.9 Air handling unit (AHU)

All-air system is commonly used for comfort applications.

7.2.3.9.1 Selection criteria

The designer shall select the air handling unit on the

basis of supply air temperature and volume; outdoor air requirement; desired space pressure; heating and cooling coil capacity; humidification and dehumidification capacity; return, relief, and exhaust air volume requirement; filtration, and the corresponding pressure capability of the fan(s).

Air handling unit is of sectionalized construction, with each section depth limited to 1 m in order to facilitate its transportation to site, hoisting and placing in AHU room and assembling the sections in mounted position. The designer shall ensure that the AHU sections are accessible for easy maintenance. Control system shall not be overly complex in its arrangement to provide the required conditions. The AHU overall dimensions are decided by keeping the face velocity across filter and coil section less than 2.0 m/s.

7.2.3.9.2 Fan

Fan selection should be based on efficiency and sound power level throughout the anticipated range of operation, as well as on the ability of the fan to provide the required flow at the anticipated static pressure. For AHU fans requiring a shaft power of 2 kW or more, the fan efficiency grade (FEG rating) shall be FEG 71 or higher (*see 11.7.1*). The operating total efficiency, in percent, at the selected point of operation for a given application shall be within 10 percent (absolute value) of FEG value. For example, for a fan of size 800 mm with a peak total efficiency of 75 percent (FEG 80), the operating total efficiency shall be between 65 and 75 percent.

7.2.3.9.3 Cooling coil

The cooling medium flowing through cooling coil can be either chilled water or refrigerant. In all finned coil, some air passes through without contacting the fins or tubes. The amount of this bypass can vary typically from 10 percent for a four-row coil at 2.0 m/s, to less than 2 percent for an eight-row coil at 1.5 m/s. The dew point of the air mixture leaving a four-row coil may satisfy a comfort installation with up to 25 percent outdoor air (10 percent for humid climates), a small internal latent load, and sensible temperature control only.

7.2.3.9.4 Reheat coil

Reheat coil is heating coil placed downstream of a cooling coil. Reheat system is strongly discouraged, unless recovered thermal energy is used. Reheat coil is used to provide precise humidity control, which is generally not required for comfort conditions in most applications. Either reheat or desiccant is usually required to dehumidify outdoor air. Reheating is necessary for laboratory, health care, or similar applications where temperature and relative humidity

shall be controlled accurately. Hot-water coil, which provides a very controllable source of reheat energy, and thereby accurate relative humidity control is the preferred option for reheat coil. Condenser water recirculation through reheat coils may be considered for energy saving.

7.2.3.9.5 Humidifier

Humidifier shall be installed as part of the air handling unit only where close humidity control of selected spaces is required. For comfort installations requiring humidity control, moisture can be added to the air by mechanical atomizer or point-of-use electric or ultrasonic humidifier placed in the conditioned area.

7.2.3.9.6 Air to air energy recovery device

Energy recovery device is often used to precool the incoming hot and humid outdoor air, by the exhaust portion of the cool and dehumidified conditioned air. Sensible heat recovery device only exchanges sensible heat (temperature only) between the two streams of air, whereas energy recovery device, exchanges heat as well as moisture. In cases of high latent loads, energy recovery device should be used to save energy.

7.2.3.9.7 Fan coil unit (FCU)

Basic components of fan-coil unit are identical to those of the AHU, namely, the filter, cooling coil, fan, and temperature control device. Fan coil unit has draw-through configuration, therefore, filter is first encountered by conditioned air. Filter will be detachable for easy replacement and for cleaning by water spray. Fan recirculates air from the conditioned space through the coil, to cool/heat the air. The fan and motor assembly shall be arranged for quick removal for servicing. If the unit includes a cooling coil, it shall be equipped with an insulated stainless-steel drain pan. The casing shall be internally insulated for both thermal and acoustic considerations.

Fan motor control shall be provided with speed control for modulating air delivery, and as additional control over cooling and dehumidification. Coil's water-valve piping package shall include flow controls (manual or automatic), pressure-independent water balancing valves, strainer, unions, pressure-temperature ports, air vent, flexible connections and drain.

7.2.4 Chilled Beam/Chilled Slab

7.2.4.1 Chilled beam

Two types of chilled beams, passive and active, are in use. Passive chilled beam consists of a chilled water coil mounted inside a cabinet. Chilled water is piped to the convective coil at between 13°C and 17°C. In order to ensure proper dehumidification and adequate fresh air delivery to the spaces, passive chilled beam

requires a separate ventilation system. If more ventilation air is needed to meet the space requirements, the volume of air can be split between the passive beam and high induction diffusers. Care shall be taken in selecting diffuser locations to coordinate well with the convective currents required by the chilled beam. Overcooling of chilled beam shall be avoided during cooling season, to prevent discomfort, condensation and microbial growth in spaces.

Active chilled beam operates with induction nozzles that entrain room air and mix it with the primary or ventilation air that is ducted to the beam. Chilled water is piped to the coil at between 13°C and 17°C. Primary air should be ducted to the beam at 13°C or lower to provide proper dehumidification. Active beams can have either a two or four-pipe distribution system. The two-pipe system may be cooling only or two-pipe changeover. Active beams may be designed to heat and cool the occupied space. In all chilled beam installations, flow control valves and chilled water supply temperature reset shall be provided. Vertical chilled beams shall be provided with condensate drain.

7.2.4.2 Chilled slab/ceiling and radiant floor

Radiant cooling and heating system provides an opportunity to achieve significant energy and peak demand savings, compared to conventional all-air system.

Radiant cooling systems can have circulation of water in pipes or tubes embedded in floor or ceiling or even on other surfaces such as walls. Chilled water is circulated through the floor/ceiling embedded pipes between 15°C and 17°C temperature for cooling applications and between 20°C and 35°C for heating applications depending upon the load conditions. Tubes can also be fitted in raised floor or suspended ceiling, with proper condensate drain, flow and temperature control. Looping of tubes/pipes shall be done for switching on/off cooling in particular area/pocket of the space as per the usage pattern.

Some low-energy cooling strategies such as displacement ventilation, natural ventilation, thermal mass, night ventilation shall be combined with radiant cooling to make it more effective.

Since the radiant cooling can take care of only sensible loads, parallel schemes are required for latent loads. These methods may form part of the ventilation strategy such as dedicated outdoor air system.

Operative temperature or effective temperature approach shall be used while designing these systems.

7.2.5 Under Floor Air Conditioning

Under floor air distribution (UFAD) is an alternate to

ceiling/side based overhead air distribution system. UFAD system has several potential advantages over traditional overhead system, including improved thermal comfort, improved indoor air quality, and reduced energy use due to delivery of conditioned air right at the occupant level.

Under floor system is generally configured to have a relatively large number of smaller supply outlets, mostly in close proximity to the occupants, as compared to a conventional overhead system. Outlets may be floor diffusers, or desktop or partition outlets as part of a task/ambient conditioning (TAC) system. All these outlets are generally equipped with individual control. Air is returned from the room at ceiling level.

7.2.6 Piping and Water Distribution System

7.2.6.1 Material

Steel piping with welded or flanged/coupled joints should be used for water recirculation and distribution in central air conditioning system. Dielectric coupling shall be used to avoid corrosion when choosing different material combinations.

7.2.6.2 Design principles

The system design should achieve the following main objectives:

- a) A good distribution of water to the various heat exchangers/cooling coils at all conditions of load, matching with temperature, humidity and pressure control strategies.
- b) Adequate provision should be made for balancing, measuring flow rates and maintaining pressure differentials.
- c) Pipe sizing shall be based on a balance between capital cost and operating cost.

Excessive water velocities should be avoided, as they lead to higher energy consumption and noise at pipe junctions and at bends.

In a large system when multiple water-chilling packages have to be used, control of the machines and the arrangement of the water circulation should be considered as an integrated whole.

Expansion tank shall be provided to cater for volume changes due to changes in temperature of the large volume of water filled within the system. System connection to expansion tank shall never be shut off. To maintain positive pressure during pump off situation, the open-type expansion tank shall be located at the highest point. Alternately, an inert gas pressurized closed expansion tank may be installed at a lower level. Air separator shall be provided in the chilled water system to improve the life and

efficiency of chilled water piping and heat exchange equipment.

Soft water shall be used for central chilled water air conditioning system, as the heat transfer medium to convey heat from the air-handling units to the primary refrigerant in the evaporator. Special applications with temperature lower than 5°C shall be provided with additives to depress the freezing point and avoid freeze-up damage to the chiller.

Next generation fluids maybe considered to enhance heat exchange efficiency, based on nanotechnology, to reduce energy consumption.

7.2.6.3 Piping design

Water velocity shall be in the range of 1 m/s to 3 m/s. Main headers in the plant room shall be designed for velocity around 1 m/s. Velocity in excess of 4 m/s should be avoided for acoustic reasons and for erosion control.

Friction factor in piping should not exceed 5 m of water per 100 m of pipe length. System design shall be with high temperature differential and lower flow rate so as to reduce friction and thereby reduce energy consumption.

7.2.6.4 Layout considerations

The layout of the main pipe runs should be considered in relation to the building structure to support their weight when filled with water; also to cater to the imposed axial loads during circulation. The positioning of expansion joints should be considered in relation to the branches, to accommodate small movements. Pumps should not be subjected to excessive loads from the vertical columns of piping.

Automatic air vents shall be provided at all high points in the system.

Piping system should be designed to permit proper cleaning and flushing, and should also include suitable strainers and drain points at appropriate locations. Appropriate bypass arrangement/isolation points may be provided for ease of maintenance.

7.2.7 Thermal Insulation

7.2.7.1 Air conditioning and water distribution systems, carrying chilled or heated fluids/air shall be thermally insulated to prevent undue heat gain or loss and also to prevent internal and external condensation. Vapour seal shall be provided on chilled water pipes to avoid possibility of condensation.

7.2.7.2 The thermal insulation material shall be selected based on following physical characteristics:

- a) *Fire properties* — Insulating materials shall be non-combustible and, in case of fire, shall

not produce noxious smoke and toxic fumes. Materials and their finishes should inherently prohibit rotting, mould and fungal growth, attack by vermin, and should be non-hygroscopic.

- b) Material should not give rise to objectionable odour at the temperature at which they are to be used.
- c) It should not cause a known hazard to health during application, while in use, or on removal, either from particulate matter or from toxic fumes.
- d) It should have a low thermal conductivity throughout the entire working temperature range.
- e) It should have good mechanical strength and rigidity, otherwise it should be clad for protection.

7.2.8 Ductwork, Air Distribution and Fan System Interface

7.2.8.1 Material

Ductwork is normally fabricated, erected and finished to the requirements in accordance with accepted standard [8-3(4)]. Designer should specify the requirements as appropriate for the velocity and pressure, and material to be employed. Ductwork is generally manufactured from galvanized steel sheet. Ductwork may also be manufactured from aluminium sheet for applications like operation theatres and intensive care units, where stringent cleanliness standards are a functional requirement. Special applications may warrant use of stainless steel or treated mild steel. Wherever, galvanized steel sheet, or aluminium sheet is used, the same shall conform to the accepted standard [8-3(5)] and [8-3(6)], respectively. Where building materials, such as concrete or brick, are used in the formation of airways, the interior surface should be fire resistant, smooth, airtight and not liable to erosion.

7.2.8.2 Ductwork design

Design calculations made to determine the size and configuration of ductwork in respect of pressure drop and noise generation, should conform to standard methods. The preferred duct profile is circular or elliptical to minimise the friction loss, however, ceiling space limitations invariably lead to rectangular duct. From aerodynamic principles, the aspect ratio of a rectangular duct, that is height to width ratio, should be kept within 1 : 3.

Ductwork design should also take into account the recommendations for fire protection (*see* Part 4 'Fire and Life Safety' of the Code) relating to the design of

air handling system, for fire and smoke control in buildings.

7.2.8.3 Layout consideration

When designing ductwork, consideration should be given to,

- a) co-ordination with building, architectural and structural requirements;
- b) co-ordination with other services;
- c) simplifying installation work;
- d) providing facilities and access for commissioning and testing;
- e) providing facilities and access for operation and maintenance of dampers;
- f) meeting fire and smoke control requirement; and
- g) prevention of vibration and noise transmission to the building and conditioned areas.

7.2.8.4 Fan connection to duct system

The performance of a fan when installed in a system, can be adversely affected by the flow conditions at fan inlet and outlet. Manufacturer's fan performance ratings are mostly based on optimum arrangement of fan inlet and outlet connections, to provide uniform straight flow conditions.

7.2.8.4.1 Outlet duct

A system designer shall closely examine the manufacturer's fan ratings to determine the conditions under which the fan has been tested. Fans intended for supply air applications are normally tested with an outlet duct. To achieve the rated performance for centrifugal fans, it is recommended to connect an outlet duct of one effective duct length (EDL), which is defined as a minimum of 2.5 equivalent duct diameters (EDD). Equivalent duct diameter for a rectangular duct is the diameter of a circular duct having the same cross-sectional area as the fan outlet. For fan outlet velocity higher than 12.5 m/s, additional length of one EDD, for each 5 m/s increment, should be added. The absence of an outlet duct in case of a tube axial fan does not result in any additional pressure losses. However, for a vane axial fan, a minimum of 50 percent EDL is required for them to perform as per the ratings.

7.2.8.4.2 Outlet duct elbow

Pressure loss in duct elbow is minimum when air approaching the elbow has uniform velocity profile. For centrifugal fan, elbow should be mounted after the outlet duct. In case of a tube-axial fan, outlet duct can be installed at fan outlet without causing additional loss. For vane-axial fans also, additional pressure loss can be made negligible by using a four piece mitre

elbow, and placing it after a minimum of 12 percent EDL.

7.2.8.4.3 Volume control damper (VCD)

Manufacturer's pressure drop rating of wide open control damper is usually based on uniform approach velocity profile. To achieve this rating, VCD should be mounted after the outlet duct specified above.

7.2.8.4.4 Inlet duct

Non-uniform flow and swirl at fan inlet is the most common cause of deficient fan performance. The performance of a tube axial fan is severely compromised in the absence of an inlet duct. An inlet duct length equal to one impeller diameter, a bell mouth/ conical inlet, or a combination of the two, is recommended to minimise pressure loss and substantially enhance fan performance.

7.2.8.4.5 Inlet duct elbow

Elbows connected at or close to fan inlet make the approach velocity profile non-uniform. In addition they can cause pressure fluctuations, instability and excessive noise. It is strongly recommended that an inlet elbow be installed at least 3 inlet diameters away for an axial or centrifugal fan. The cross-sectional area of the inlet duct should be within -7.5 percent to +12.5 percent of the fan inlet area. A four piece mitre elbow is preferred over a two piece elbow.

7.2.8.5 Cabinet effect

Restricted fan inlet as in the case of inlet placed too close to a wall or inside a cabinet, adversely impacts fan performance. Fans inside plenum/cabinet, or next to walls, shall be placed so as to allow unobstructed air flow into fan inlet. A minimum distance of 75 percent of inlet diameter shall be provided between fan inlet and the wall. In case of two or more double inlet double width (DIDW) centrifugal fans placed side by side, a minimum separation of one inlet diameter shall be provided between the two adjacent inlets. The position of cabinet inlet should be symmetrical with the fan inlet to avoid uneven inlet flow or inlet spin.

7.2.9 Geothermal Energy

Ground source heat pump (GSHP) systems are largely based upon the fact that temperature of earth 3 m below the virgin ground level remains almost constant throughout the year, at annual mean temperature of that place. Such systems exchange heat with ground or with an aquifer inside the ground.

GSHP system consists of three parts, namely, ground heat exchanger, heat pump unit and air delivery system, that is, similar to any conventional air conditioning system.

The ground heat exchanger can be a closed loop laid horizontal, vertical, immersed in pond, or in lake, or even in sewer line.

Decision about heat exchanger type shall be taken considering load, soil conditions, available land area and the local installation cost. The same loop works for both heating and cooling.

In cooling demand dominated climates, the depth of the horizontal loop should be at least 3 m to reduce efficiency losses in the late summer, due to drying of soil. In heating demand dominated areas, the depth may be reduced to 2 m. Antifreeze should be used in cold places. Antifreeze should be biodegradable and should present no hazard to the environment. All pipes should have the minimum cell classification number imprinted on the pipe. To create closed-loop systems, pipe and fittings shall be connected by butt or socket fusion (heat fusion) or stab fittings. Barbed fittings and clamps should not be used as they result in potential leaks and joint failure when used with high density polyethylene pipe. All pipes shall be pressure tested, then connected to the heat pump inside the building and trenches shall be backfilled.

For a vertical ground loop system, multiple boreholes shall be drilled 3 m to 5 m apart and 30 m to 120 m deep, depending on the thermal conductivity (TC) test. Two separate pipe lengths shall be connected with a U-bend to form a loop, then placed in each borehole and pressure tested. The borehole shall be backfilled with a grouting material and sealed off at the surface. Vertical loops shall be tied together with a system of horizontal piping laid in trenches, then connected to the heat pump in the building.

Pond/lake/sewer loops depend on the location of a pond or lake or sewer mains near the building. Loop coils should not be placed in a river or a body of water where fluctuating water levels or flood stage conditions can damage the pipe. Loop coil should be submerged in a fairly large body of water, at least 2.5 m deep, to prevent freezing in winter, and from exposing of tubes due to shortage of water in summer.

In an open-loop system, once the water has circulated through the heat pump, it is returned to the ground through one of the several methods, namely, a recharge well, a drain field or through surface discharge. This option should be used only where an adequate supply of water is available. About 15 litre per minute of water is required for each tonne of heating and cooling.

Thermal conductivity and thermal diffusivity (GHX TC) tests should be conducted before designing GSHP system:

- a) *GHX TC test equipment* — Thermal

conductivity test for vertical or horizontal borehole consists of,

- 1) determining the ambient deep-earth-ground temperature,
 - 2) injecting heat into borehole at known rate (BTU/h or kW),
 - 3) determining the ΔT between fluid entering and leaving the GHX, and
 - 4) calculating thermal conductivity using the line-source method.
- b) *Thermal conductivity test unit* — It shall consist of,
 - 1) circulation pump,
 - 2) electric elements,
 - 3) entering and leaving water temperature sensors,
 - 4) data logger, and
 - 5) power supply for electric elements.
 - c) *Typical TC test results* — A typical TC test report shows the entering and leaving water temperatures from the U-tube, as well as energy input. Data is typically logged in 1 to 5 min intervals, for the duration of the test. Standard method of testing shall be followed.

7.2.10 District Cooling System

7.2.10.1 District cooling system comprises of collective equipment to produce and distribute chilled water. Chilled water is produced by production plant and distributed by water pipes (the distribution network) to buildings equipped with energy transfer stations (sub-stations). Chilled water thus supplies some of its cooling to the building's installations. Such cooling system always operates in closed-circuit configuration and includes at least two water pipes; one of which carries the chilled water to the end user, and the other which carries it back towards the production plant.

In such a system, thermal energy produced at a central location is thus distributed to a set of consumers in commercial, residential and/or institutional buildings. This enables the consumer to air condition the building without having to install individual cooling (or heating) plant. Principle is similar to distribution of electricity to a number of consumers by an electrical distribution company. It is therefore the preferred air conditioning system for green-field cities and for large mixed-use development projects.

Some of the advantages of district cooling system are as follows:

- a) Chilled water can be produced at one dedicated place, using large, highly efficient

chillers. User buildings need to provide minimal space for the tertiary equipment, and for metering of chilled water or of cooling energy (BTU meter).

- b) Total installed capacity and peak load of the air conditioning system get significantly reduced, due to large diversities in the cooling loads from diverse building usage pattern in the district.
- c) Problems of plant operation and maintenance are confined to a centralized location, instead of distributing across the district.
- d) Since air conditioning plant consumption is generally of the order of 40 percent of building energy consumption, power distribution system for the district will become lighter and cables sizes much smaller.
- e) Problems of noise and vibration are confined to a place where it need not be objectionable.

7.2.10.2 Distribution of insulated chilled water pipes shall follow dedicated routes and adequate space for easy laying and maintenance. These are generally laid in trenches with removable covers and identifying markers. These trenches need to be integrated in the district planning.

7.2.10.3 Cogeneration

Cogeneration is the simultaneous production of electric power and thermal energy in a useful form such as steam, hot water and low temperature chilled water, all from a single energy source such as coal, oil or gas. Such systems are found useful in establishments where combined cooling/heating and power are simultaneously consumed. Good examples are, factory, hotel, hospital, etc, requiring cooling with chilled water; simultaneously with substantial electric power consumption. Cogeneration system presents a 50 percent to 70 percent more efficient utilization of the source of energy, that is, coal, oil or gas. Cogeneration is extensively used with district cooling systems.

7.2.11 Window (Unitary) Air Conditioner

7.2.11.1 Window (unitary) air conditioner is generally used for the following functions:

- a) Cooling and general dehumidification, and
- b) Cooling and heating by heat pump.

7.2.11.2 Suitability

Window (unitary) air conditioner is suitable for bedroom, office cabin, general office area, hotel room and similar applications, where normal comfort conditions are required to be maintained within a distance of 6 m from the window air conditioner.

7.2.11.3 Noise level

Noise level of window air conditioner inside the conditioned room should be as low as possible. It shall meet the requirements specified in the accepted standard [8-3(7)].

7.2.11.4 Location

Window (unitary) air conditioner should be mounted preferably at the window sill level on an external wall, where hot air from air-cooled condenser can be discharged without causing nuisance. There should not be any obstruction for the inlet air to, and discharge air from, the condenser. While deciding location of the window air conditioner, care shall be taken to ensure that the condensate drain water is piped to the ground level and does not drip, causing nuisance.

Window air conditioner is not recommended for special applications, like sterile rooms for hospitals and clean room applications where high filtration efficiency is desired, nor in applications where high percentage of fresh air is desired and fire hazard exists, such as operation theatres depending on the type of anaesthesia being used. It is also not suitable for areas that require close control of both the indoor temperature and relative humidity.

7.2.11.5 For detailed information regarding constructional and performance requirements and methods for establishing ratings of window (unitary) air conditioners, reference shall be made to the accepted standard [8-3 (7)].

7.2.12 Split Air Conditioner

7.2.12.1 It comprises of an indoor unit and an outdoor unit. The indoor unit may be mounted on floor or on wall, or at ceiling. The outdoor unit consists of compressor, heat exchanger, fan and motor; installed in a separate independent cabinet. The indoor unit is an air handling system, designed primarily to provide conditioned air to an enclosed space, room or zone (conditioned space). It includes a prime source of refrigeration for cooling and dehumidification/heating and means for the circulation and filtering of air.

Various types of split air conditioners may be categorized based on type of compressor for outdoor unit and air-distribution for indoor unit, as below:

- a) *Outdoor unit with variable speed compressor* — It is also called an inverter AC or variable speed AC, which works on part load depending on the demand for the conditioned space. This uses a variable-frequency drive to control the frequency and thereby the speed of the compressor motor.
- b) *Outdoor unit with fixed speed compressor*

- c) *Free-blow indoor unit* — It could be high wall mounted, ceiling suspended cassette (exposed type), or floor-mounted.
- d) *Furred-in indoor unit (ceiling suspended)* — It is mounted in the ceiling and provided with a duct collar and grille.
- e) *Ducted indoor unit* — It requires ducting for air distribution.

7.2.12.2 Suitability

Split air conditioner is suitable for wide range of applications including residences, small office, club, restaurant, showroom, departmental store, and others.

7.2.12.3 Operating parameters

In general, nominal capacity of the split air conditioner gets de-rated for the high ambient temperature (above 35°C) in summer months, in most of Indian cities. Also, generally a voltage stabilizer shall be required to get stabilized rated voltage as per specifications defined by manufacturer. For 3-phase unit, it is recommended to use phase reversal protection device in power supply to the outdoor unit.

7.2.12.4 Location

Split air conditioner indoor unit is mounted within the air conditioned space or above the false ceiling room from where the air distribution duct is taken to the conditioned space to distribute the conditioned supply air. When the indoor unit is mounted in the false ceiling, inspection panel shall be kept in the false ceiling to attend to the indoor unit, and periodic cleaning requirement of air filter. Outdoor unit is mounted at the nearest open area where unobstructed flow of outside air is available for the air cooled condenser.

7.2.12.5 Installation

Wall mounted unit and similar exposed indoor unit are provided with installation plate for ease in installation. Care shall be taken to ensure that enough clearance space is available below the ceiling in order to have free intake of return air.

Ceiling suspended indoor unit is provided with rubber grommets to minimise vibration transmission to the ceiling.

Outdoor unit is mounted on an epoxy-coated steel frame in an open area so that the fan of the air cooled condenser can discharge hot air to the atmosphere, without any obstruction. Care should be taken to ensure that free intake of air is also available to the outdoor air cooled condenser. Also precaution should be taken that hot air from any one outdoor unit does not mix with the outdoor air intake of any other air cooled condenser.

Service valves are to be provided for proper pressure testing of the system for leaks, for evacuation of moisture and air from the system, and to carry out predetermined gas quantity charge into the system. Also in case of maintenance of any part, these valves can be used to isolate and to store the entire refrigerant charge within the outdoor unit by pumping down, thus saving the entire charge of refrigerant.

Split units shall be installed as per the procedure given in 12.2.

7.2.12.6 Limitations

Split air conditioner is generally not recommended for,

- a) where distance between indoor unit exceeds beyond the maximum of 30 m (or higher as per the recommendation of the manufacturer) from the outdoor unit for units up to 17 500W (5 TR). The horizontal distance between the indoor unit and outdoor unit should not exceed 10 m for reciprocating compressor, nor for scroll compressor. The vertical distance between the indoor unit and the outdoor unit should not exceed 10 m for units with reciprocating compressor, and 25 m for unit with rotary/scroll compressor.
- b) area requiring close control of both the indoor temperature and relative humidity.
- c) sound recording rooms where criteria for acoustics are stringent.
- d) special applications like sterile rooms for hospitals and clean room applications where high filtration efficiency is desired.
- e) large multistoreyed buildings where multiplicity of compressors may entail subsequent maintenance problems.

7.2.12.7 For detailed information regarding constructional and performance requirements and methods for establishing ratings of split type room air conditioners, reference shall be made to the accepted standard [8-3(8)].

7.2.13 Packaged Air Conditioner

7.2.13.1 Packaged air conditioner is a self-contained unit suitable for floor mounting, designed to provide conditioned air to moderate sized conditioned spaces. It includes prime source of refrigeration for cooling and dehumidification, distinct facility for drawing of fresh air and mixing with return air, means for cleaning of mixed return and fresh air, and generally provision for external air distribution ducting for uniform air distribution in the conditioned spaces. It may also include winter heating package and humidification package for winter operation. The machine is equipped with compressor, evaporator, expansion device and

remote air cooled condenser or water cooled condenser with interconnected copper refrigerant piping.

Water-cooled condenser packaged unit gives higher capacity at lower power consumption as compared to an air-cooled condenser packaged unit which gets considerably de-rated in capacity for high ambient temperature (beyond 35°C) in summer months for most of the cities in India. Air cooled package unit consequently also consumes more power in peak summer months. On the other hand, water-cooled condenser unit requires cooling tower with necessary piping and pump sets for circulating condenser-cooling water, but is far more energy efficient due to our low ambient wet-bulb temperatures in summer months.

Packaged units are generally available with vertical air discharge; however, horizontal air discharge unit may also be procured but heat island effect should be avoided.

7.2.13.2 Suitability

Packaged unit is suitable for wide range of applications including office, club, restaurant, showroom, departmental store, banquet halls and others.

7.2.13.3 Location

Packaged unit can be mounted within the air conditioned space with discharge air plenum or in a separate room from where the air distribution duct is taken to the conditioned space. While deciding location for the packaged unit, provision shall be kept for ease of servicing of the unit.

7.2.13.4 Installation

Packaged unit is normally mounted on resilient pads which prevent vibration of the unit from being transmitted to the floor.

7.2.13.5 Limitations

Packaged air conditioner is generally not recommended for,

- a) large multi-storeyed buildings, where multiplicity of compressors may entail subsequent maintenance problems.
- b) where the length of air distribution ducting may exceed approximately 30 m. However, duct length limitation depends upon permissible external static pressure specified by the manufacturer.
- c) where the vertical distance of air-cooled condenser from the packaged unit exceeds about 20 m. The sum of horizontal and vertical distance should generally be kept within 25 m.
- d) special applications like sterile rooms for hospitals and clean room applications where

high filtration efficiency is desired. For these applications, special packaged units are available with high micron efficiency filters.

- e) applications, such as, operation theatres where high percentage of fresh air is needed and fire hazard exists depending on the type of anesthesia being used.

7.2.13.6 For detailed information regarding constructional and performance requirements and methods for establishing rating of packaged air conditioner, reference shall be made to the accepted standard [8-3(9)].

7.2.14 Variable Refrigerant Flow (VRF) System

7.2.14.1 Variable refrigerant flow (VRF) system is a direct expansion (DX) multi-split system with variable speed compressor, capable of delivering capacity according to variable load requirement. By operating at variable speeds, VRF unit delivers required capacity allowing for substantial energy savings at partial-load conditions. VRF system has each outdoor unit connected with multiple number of indoor units *via* refrigerant piping, an attribute that distinguishes VRF system from other DX systems. Other advantages of VRF system are its scalability, variable capacity, distributed temperature control, and the standards cooling/heating mode application.

VRF system achieves temperature control on a zone by zone basis primarily by using refrigerant side control. As compared to DX system, VRF indoor unit has an additional electronic expansion device to control refrigerant flow passing through evaporator coil, to control indoor temperature precisely, based on the instantaneous load requirement.

VRF system is available with a dedicated air handling unit for supply of tempered fresh air (TFA). In order to cater to fresh air needs, VRF system outdoor unit should be connected with TFA-AHU. A control box equipped with electronic expansion device and communication printed circuit board (PCB) is needed for TFA-AHU so that it can communicate seamlessly with the VRF system outdoor unit.

VRF technology comes in two pipe or three pipe system. In a 2-pipe heat pump system, all of the zones shall either be in cooling mode or in heating mode. Application requiring simultaneous heating and cooling should have 3-pipe systems for enabling heat recovery.

7.2.14.2 Configuration

VRF system is available with air cooled or water cooled condenser.

Outdoor unit in VRF system can have multiple compressors, with one or more compressor provided

with variable speed control. Generally for air cooled VRF system, outdoor unit is available both with top discharge and with side discharge.

7.2.14.3 Suitability

VRF system is suitable for wide range of applications including residence, apartment, villa, small and big office, club, restaurant, showroom, departmental store, healthcare facility, hospitality, cultural facility, educational facility and industrial facility.

In VRF system, depending on application, same or different types of indoor units can be connected to a single outdoor unit or to multiple outdoor units. VRF indoor units and air handling units for fresh air or for special treatment of re-circulated air, can be connected to the same refrigerant line, to facilitate more flexible system design, in mid and large size applications. However, usage of bigger AHU in VRF systems may have evident effect on the part load energy efficiency advantage of the system.

7.2.14.4 Controls

VRF system usually has factory-packaged integral controls in each component; these communicate through their system specific protocol, to ensure that all system components operate collectively. VRF indoor and outdoor units include refrigerant and air side sensing and control devices which allow the system to optimize its output (compressor speed, discharge temperature, fan speed) based on inputs from controllers. Depending on the application and design, a VRF system is able to operate with many levels of controls. Different types of controllers are available to cater to various requirements, as given below:

- a) Individual/group controller,
- b) Centralized controller with remote monitoring and control, and
- c) Interface with building management system.

7.2.14.4.1 Individual/group controller

VRF indoor units can be controlled individually with wired or wireless individual remote controller. Control options include, 'ON/OFF', temperature change, mode change, and fan speed change. Applications such as a large common area in which multiple indoor units are running simultaneously, at the same condition, can be controlled by a single remote controller by combining these indoor units as a group. All setting conditions remain same for all indoor units connected in the group. Each of the grouped indoor unit may operate according to the sensed return air temperature.

7.2.14.4.2 Centralized controller with remote monitoring and control

Centralized controller allows users to operate and

monitor multiple indoor units centrally. Besides having all functions of individual remote controller, centralized controller has the additional facility of scheduling energy saving by operation restrictions and web monitoring. In some applications, single outdoor unit is used by different tenants connected to different indoor units. In such cases, centralized controller offers facility of tenant billing through software application, depending on individual usage through proportional power distribution.

Some manufacturers offer smart phone application as it provides easy access and human interface for the VRF system user giving flexibility to operate and monitor the system remotely.

7.2.14.4.3 Interface with building management system

VRF system should be integrated with building management system if available, with the use of different interface gateways that communicate with different protocols. With this interfacing, it is easy to operate and monitor air conditioning with user's building management system.

7.2.15 Evaporative Cooling — Indirect Direct Cooling System

7.2.15.1 The various components of the indirect-direct cooling system are as follows:

- a) Filters;
- b) Cooling coil/heat exchanger [for indirect cooling (sensible heat exchanger)];
- c) Cellulose pads [for evaporative (direct or adiabatic) cooling];
- d) Fan section with enclosure for fan, filters, heat exchanger, cellulose pads with piping, moisture eliminators and dampers;
- e) Cooling tower;
- f) Pumps for heat exchanger and cellulose pads; and
- g) Piping with valves and fittings.

7.2.15.2 The indirect cooling can be done by using following systems for dissipating the heat at air cooling coil/heat exchanger:

- a) Through water in open cooling tower;
- b) Through liquid in closed loop cooling tower;
- c) Through liquid in closed loop geothermal system;
- d) Through water in open loop — lake or pond geothermal system;
- e) Through specially designed plate type heat exchanger; and
- f) Through refrigerant circulating in cooling coil of the refrigeration system.

7.2.15.3 This system is more useful in areas having moderate ambient temperature and especially low wet-bulb temperature. The system can be used using both stage of cooling during peak summer conditions giving outlet dry-bulb lower than ambient wet-bulb temperature. In monsoon, only indirect cooling can be used where the moisture is not added in the already moist ambient air.

7.2.15.4 It is good practice to have 100 percent fresh air system for evaporative cooling. During summers in the dry climates, outlet temperature is much lower; it can reduce the amount of air required to dissipate or remove the heat from the enclosed area, especially in industrial applications or applications where only comfortable temperature range is acceptable.

7.2.15.5 The air velocity across cooling surface is recommended between 2 and 2.5 m/s. Heat exchange is better at the lower face velocity while with higher face velocity, heat exchange is compromised.

7.2.15.6 Saturation efficiency of these indirect/direct coolers are normally in excess of 100 percent, making these a very effective solution for comfort applications in dry climates.

7.2.15.7 For detailed information regarding air capacity, constructional features, performance requirements and methods of testing of evaporative air cooler, reference shall be made to the accepted standard [8-3(10)].

7.3 Factors to be Considered for Different Applications

The general guidance, for various selected applications, for the factors that usually influence the selection of the type, design and layout of the air conditioning or ventilating system, to be used are given in **7.3.1** to **7.3.6**. The primary objective of these is to define the special provisions required for the air conditioning system, to ensure comfort conditions for occupants in the respective applications.

7.3.1 Office Building

Office building may include both the outer and inner zones. The outer zone may be considered as extending from approximately 4 m to 6 m inwards from the outer wall of the building, and is generally subjected to wide load variation owing to daily and annual changes in outside temperature and solar radiation. Ideally, the system(s) selected to serve an outer zone should be able to provide summer cooling and winter heating. During intermediate seasons the outer zone of one side of the building may require cooling and at same time the outer zone on another side of the building may require heating. The main factors affecting load are usually window area and choice of shading devices.

The other important factors are the internal gain owing to people, light and office equipment. Choice of system may be affected by requirements to counteract down-draughts and chilling effect due to radiation associated with single glazing during winter. Cooling load for inner zone is generally entirely from the heat gain from people, lights and office equipment, which is generally fairly uniform throughout the year.

Other important considerations in office building application may include requirements for individual room control, partitioning flexibility serving multiple tenants, and requirement of operating selected areas outside of normal office hours. Areas such as conference room, board room, canteens, etc, will often require independent system. For outer building zone with large glass area, for example, greater than 60 percent of the external facade, the air-water type of system, such as induction or fan coil is generally economical than all-air system and has lower space requirement. For outer zones with small glass area, an all-air system, such as variable volume, may be the best selection. For building with average glass area, other factors may determine the choice of system. For inner zone, a separate all-air system with volume control may be the best choice. System employing reheat or air mixing, while technically satisfactory, is generally poor as regards energy conservation.

Each system or each zone within a system shall be provided with not less than one thermostat capable of being set from 15°C to 30°C and capable of operating the system's cooling and heating. The thermostat or control system, or both, shall have an adjustable dead band, the range of which includes a setting of 12°C between heating and cooling where automatic changeover is provided. Wall mounted temperature control shall be mounted preferably on an inside wall and shall meet the requirements given in **13** and Annex B of Part 3 'Development Control Rules and General Building Requirements' of the Code for universal accessibility.

7.3.2 Hotel Guest Rooms

Each guest room or each zone shall be provided with not less than one thermostat capable of being set from 15°C to 30°C and capable of operating the system's cooling and heating. The thermostat or control system, or both, shall have an adjustable dead band, the range of which includes a setting of 12°C between cooling and heating, where automatic changeover is provided. Wall mounted temperature control shall be mounted preferably on an inside wall and shall meet the requirements given in **13** and Annex B of Part 3 'Development Control Rules and General Building Requirements' of the Code for universal accessibility.

Guest room systems are required to be available for

operation on a continuous basis. The room may be unoccupied for most of the day and therefore provision for operating at reduced capacity, or switching off, is essential. Low operating noise level, reliability and ease of maintenance are essential. Treated fresh air (TFA) is introduced through an independent TFA system, it is generally balanced with the bathroom extract ventilation, to ensure air circulation into the bathroom. Fan coil unit is generally found to be the most suitable for this kind of application with speed control for fan and motorized/modulating valve for chilled water control for cooling.

7.3.3 Restaurant, Cafeteria, Bar and Night Club

Such applications have several factors in common; highly variable loads, with high latent gains (low sensible heat factor) from occupants and meals, and high odour concentrations (body, food and tobacco smoke odours) requiring adequate control of fresh air extract volumes, direction of air movement for avoidance of draughts and make up air requirement for associated kitchens to ensure an uncontaminated supply.

This type of application is generally best served by the all-air type of system preferably with some reheat or return air bypass control, to limit relative humidity. Either self-contained packaged unit or split system, or air handling unit served from a central chilled system, may be used. Sufficient control flexibility to handle adequately the complete range of anticipated loads, is essential.

7.3.4 Department Store/Shop

For small shop and store, unitary split type air conditioning system offers many advantages, including low initial cost, minimum space requirement and ease of installation. For large department store a very careful analysis of the location and requirement of individual department is essential as these may vary widely, for example, for lighting department, food halls, restaurants, etc. Some system flexibility to accommodate future changes may be required.

Generally, internal loads from lighting and people predominate. Important considerations include initial and operating costs, system space requirements, ease of maintenance and type of operating personnel who will operate the system.

The all-air type of system, with variable volume distribution from local air handling unit, may be the most economical option. Facilities to take all outside air, for 'free-cooling' under favourable conditions, should be provided.

7.3.5 Theatre/Auditorium

Characteristics of this type of application are buildings

generally large in size, with high ceiling, low external load, and high occupancy producing a high latent gain and having low sensible heat factor. These give rise to the requirement of large fresh air quantities and low operating noise levels. Theatre and auditorium may be in use only a few hours a day.

Movie theatre design considerations shall be based upon timing of usage, low occupancy level and low sensible load. Special care shall be taken to ensure proper relative humidity level without overcooling the space. System design shall meet the required noise criteria. The lobby and exit passageways in a multiplex which are seldom densely occupied, although some light to moderate congestion can be expected for short times, shall be separately treated.

Stage in auditorium shall be specially treated because of heavy mobile lighting load and performance considerations.

7.3.6 Educational Institute

Special attention for the design of the HVAC systems shall be paid to meet the needs of every age group. The equipment should be easy to operate and maintain and the design should provide no drafts. These facilities have two distinct occupant zones: (a) the floor level, where younger children play, and (b) normal adult height, for the teachers. The administrative and teachers offices shall be considered as a separate zone.

Special consideration shall be given to operating schedule for setback. Supply air outlets should be positioned to avoid drafts. Proper ventilation and exhaust shall be provided for controlling odours and to prevent the spread of diseases.

University and college campus having large diversity in cooling/heating loads, should be provided with large central utility plant or smaller mechanical rooms serving a cluster of buildings. The central utility plant may supply chilled/hot water. The designer should consider site constraints, including geographic location. In addition to accommodating the mechanical and electrical equipment, central utility plant may also house engineering, operation and maintenance personnel. A central control room shall be provided for energy monitoring.

7.4 Buildings, in which the HVAC planning and design requirements vary from a normal comfort application, such as, data centers, hospitals and underground metro stations, etc, are covered in 8.

8 SPECIALIZED APPLICATION

8.1 There are many buildings with specialized application, like, data center, hospital and underground metro station; where requirement for these varies from

a normal comfort application and hence these need to be treated differently. The requirements for such specialized applications have been given below:

- a) *Health care facility/Hospital* — Some of the spaces in health care facilities require specific conditions of temperature, relative humidity, pressure differential with respect to adjacent spaces and cleanliness levels as well as low noise. When lower temperatures are desired in comparison to general areas, multiple design philosophies are available.
- b) *Data centres* — The occupant load in data centres is nearly 1 or 2 percent of total load, rest is primarily server/equipment load. Therefore, in this type of building, the majority of load is sensible load. It is critical to maintain the operating conditions of server/equipment for their safe and consistent operation at lowest operating cost. Design needs should be identified after working closely with architect, equipment/server manufacturer and HVAC consultant.
- c) *Underground metro station* — There are two challenges to be dealt with at underground metro station:
 - 1) Tunnel air temperature which increases due to the movement of metro train in tunnel.
 - 2) Comfort condition at platform and concourse due to sudden high passengers load and metro movement (equipment load).

Both the above may be handled differently by different designers.

The methodology which may be adopted for addressing the specific requirements of above applications are given in 8.1.1 to 8.1.3.

8.1.1 Health Care Facility

Patient therapy shall be the prime consideration while air conditioning or ventilating a health care facility. While planning the air conditioning and ventilation of the health care facility, the plan shall include the clinical services to be provided in each space, equipment to be used with in the space and requirement of temperature, humidity, air flow pattern and pressure gradient with respect to adjacent spaces.

Following are the parameters which shall be taken into consideration while designing HVAC system for health care facilities:

- a) Temperature and humidity requirements of various spaces;
- b) Ventilation and filtration requirements for contamination control;

- c) Restriction on air movement between adjoining spaces;
- d) Permitted tolerance on environmental conditions;
- e) System reliability and maintainability; and
- f) Adaptability of the system for fire emergency and for smoke management.

Guidelines for the above parameters for various functional spaces in a health care facility are given in Table 6 and Table 7.

8.1.1.1 Air distribution system

Air distribution systems in a health care facility shall provide ventilation to dilute and remove contaminants and assist in controlling transmission of air borne infections besides maintaining the desired temperature and humidity. Design of the air distribution system shall be such that air movement is from clean to less clean areas. Recirculation of air should be avoided in critical care areas.

For critical care areas, constant volume systems shall be used to maintain proper pressure relations and ventilation. Critical areas in general are operating theatres, ICUs, isolation rooms, sterile areas, post-operative patient care; any place which houses medical surgical procedures and some of the laboratories.

For patient rooms and non-critical areas, variable air volume system shall be considered for energy conservation. However when variable air volume systems are used, care should be taken to ensure that minimum ventilation requirements are not compromised and pressure balance is maintained even at minimum flow.

Active smoke control systems shall be used along with fire and smoke partitions to limit the spread of smoke in the event of fire. Smoke and fire management shall be done in accordance with Part 4 'Fire and Life Safety' of the Code. For health care facilities which provide ambulatory care to patients, safety from fire and smoke is a paramount design consideration and shall be provided in accordance with Part 4 'Fire and Life Safety' of the Code.

A separate exhaust system shall be provided for removal of anesthetic gases from the operation theatre. Alternatively, proper isolation dampers may be provided in the air circulation system for removal of anesthetic gases or fumigation effect.

Air handling devices shall be designed to prevent water intrusion and permit access for inspection and maintenance.

When humidifiers are provided, they shall be located within the air handling unit or duct work in such a way

Table 6 Guidelines for Parameters to be Considered for HVAC System Design for Health Care Facilities
(Clause 8.1.1)

Sl No.	Area/Functional Space	Temperature °C	Relative Humidity Percent	Minimum Total Air Changes per Hour	Minimum Air Changes of Outdoor Air per Hour	Air Pressure in Relation to Surrounding Area
(1)	(2)	(3)	(4)	(5)	(6)	(7)
i)	Operating theatres	18-24	45-55	25	5	Positive
ii)	Cath labs	20-22	30-60	15	3	Positive
iii)	Delivery rooms	20-22	30-60	25	5	Positive
iv)	Recovery room, ICU, Treatment rooms	20-24	30-60	6	2	Equal
v)	Endoscopy, Bronchoscopy	20-24	30-60	12	2	Negative
vi)	Patient rooms	24±1	30-60	6	2	Equal
vii)	Toilets	—	—	—	10	Negative
viii)	Protective environment rooms (Immuno suppressed patients)	24±1	30-60	12	2	Positive
ix)	Isolation room (for patients with infectious disease)	24±1	30-60	12	2	Negative
x)	Corridors	—	—	2	2	Negative
xi)	X-ray/Radiology	20-24	30-60	15	3	Positive
xii)	Laboratories (Other than biochemistry and serology)	22-24	30-60	6	2	Negative
xiii)	Biochemistry and serology labs and pharmacy	22-24	30-60	6	2	Positive
xiv)	Admission/Waiting rooms	22-24	30-60	6	2	Negative
xv)	Diagnostic/Treatment OPD	22-24	30-60	12	2	Negative
xvi)	Sterilizer room	22-26	30-60	10	—	Negative
xvii)	Sterilizer storage	22-26	30-50	4	2	Positive

Table 7 Guidelines for Filter Efficiency Requirement in Health Care Facilities
(Clause 8.1.1)

Sl No.	Category	Area/Designation	Filter Efficiency	
			Filter Bed 1	Filter Bed 2
(1)	(2)	(3)	(4)	(5)
i)	Category 1	<ul style="list-style-type: none"> a) Orthopaedic OT b) Bone marrow transplant OT c) Organ transplant OT 	3 to 10 micron particles 70 percent efficiency	0.3 to 1 micron particles 95 percent efficiency (HEPA at outlets)
ii)	Category 2	<ul style="list-style-type: none"> a) General OT delivery rooms b) ICU, patient care rooms c) Treatment rooms d) Diagnostic areas 	3 to 10 micron particles 70 percent efficiency	0.3 to 1 micron particles 85 percent efficiency
iii)	Category 3	<ul style="list-style-type: none"> a) Laboratories b) Sterile storage 	0.3 to 1 micron particles 75 percent efficiency	Not required
iv)	Category 4	<ul style="list-style-type: none"> a) Food preparation b) Laundry c) Admin, etc 	3 to 10 micron particles 70 percent efficiency	Not required

that moisture accumulation on downstream components do not take place. Evaporative pan type humidifiers shall not be used.

Fibrous acoustic insulating material shall not be used as duct lining for critical spaces unless downstream terminal filters are provided. Supply air ducts shall be externally insulated as required.

Multiple direct drive plenum fans may be used in air handling units serving critical areas. This provides redundancy and minimises shut down of critical areas in case of single fan failure.

For critical areas, both supply air and return air shall be ducted. Ducts shall be sized for medium velocity and medium pressure drop (12 m/s and 4 mm for 10 m Max). For applications like operation theatres and intensive care units, the preferred material for ductwork should be aluminium sheet.

Ultraviolet germicidal irradiation is recommended for air handling units serving health care facilities. Lamps may be installed either upstream or downstream of the evaporator coil but away from the filter media.

8.1.1.2 Air flow and filtration

Outside air intakes shall be located at least 8 m away from exhaust stacks, cooling tower and/or any other polluting source. Bottom of an outside air intake shall not be located less than 2 m above ground level and 1m above any roof terrace level.

Exhaust outlets shall be located at a minimum height of 3 m away from ground level and away from doors, occupied areas and operable windows. Locating exhaust outlets above the roof, projecting upwards, is preferred.

While installing filters, care shall be taken to see that there is no scope for leakage between frame and filters and between filter segments.

All openings in ducting/diffusers collars shall be sealed to prevent infusion of dust and dirt.

All slab openings shall be terminated in enclosed rooms and airflow systems shall be designed and balanced to create positive or negative air pressure with-in specified areas.

It is recommended that supply air outlets shall be located at or near the ceiling and return/exhaust is collected near the floor level. This is to ensure that clean conditioned air moves through breathing and working space to the floor area, for return/exhaust.

For operating room and procedure room, where patients are highly susceptible to infection, such as orthopedic and cardiac operating theatres, laminar air flow system shall be considered. A unidirectional air flow pattern at a velocity of 0.45 ± 0.10 m/s should be aimed for. A vertical laminar flow system which will wash the patient on the operating table and flow downwards, to be collected near floor level, shall be chosen for such rooms. The area of laminar flow grid shall extend by a minimum of 450 mm beyond the foot print of the operating table on all sides. If required, additional supply diffusers may be provided for achievement of required temperature and humidity.

Exhaust grilles (minimum two) shall be provided at opposite corners of the room at approximately 200 mm above the floor level.

8.1.1.3 Pressure differential

Operating rooms where highly infectious patients are treated and isolation is required, an anteroom shall be provided between the operating room and external area. Anteroom shall be maintained at positive pressure with respect to both the operating room and the surrounding areas.

All air from operating rooms and from all airborne infection isolation rooms, shall be exhausted directly to outdoors and if this is not practical, the room shall

be ventilated with re-circulated air supplied through high-efficiency particulate arrestance (HEPA) filters. Such rooms shall be maintained at a minimum negative pressure of 2.5 N/m^2 with respect to surrounding areas.

Protective environment rooms, such as, bone marrow transplants and organ transplants, shall be maintained at a positive pressure of 2.5 N/m^2 with respect to surrounding spaces.

8.1.1.4 Conditioning equipment

Cooling equipment can be central or local chilled water systems, direct expansion type condensing units or variable refrigerant flow systems. Indirect cooling systems using chilled water are preferred and, if direct cooling systems are used, required safety measures should be adopted.

Heating equipment shall include heat pumps, boilers and heat exchangers.

Sizing and arrangement shall give adequate consideration to minimum loading and standby facility for critical areas. It shall be possible for the facility to operate even when one of the systems is under break down or maintenance.

Where specific areas are to be maintained at a low temperature coupled with low humidity, an additional direct expansion coil may be introduced downstream of the regular evaporator coil. In such cases, the control strategy shall ensure that the DX coil is energized only after the main evaporator coil is at full load.

When variable refrigerant flow systems are used, care shall be taken to see that minimum air change and pressure differential considerations are not compromised.

8.1.1.5 Installation and maintenance

The air distribution system shall be provided with access panels to allow inspection and cleaning. Duct systems shall be cleaned of construction debris before commissioning.

Surfaces of air terminals shall be suitable for cleaning.

Access to equipment rooms shall be planned so as to avoid intrusion of maintenance personnel into critical care areas. Equipment room layout shall allow easy access to equipment for its operation and maintenance.

Operation and maintenance records shall include indoor temperature and pressure requirements as well as permitted tolerances for all spaces. It shall also include standard operating procedures for emergencies, such as power failure, equipment breakdown and fire situation.

Pressure differentials of operating rooms, protective

environment rooms, and air borne infection isolation rooms with respect to surrounding areas, shall be verified and recorded semiannually.

HEPA filters shall be replaced periodically based on pressure drop. Filters of fan coil units and air handling units (AHU) shall be cleaned according to a regular maintenance schedule. AHU/Fan coil drain pans shall be of stainless steel construction and shall be cleaned monthly.

Supply and return air ducts for critical areas shall be tested for air leakage and an air blow down process shall be undertaken before loading of filters. All areas served by the AHU shall be cleaned and mopped before the AHU is started. Filters shall be loaded in sequence. Pre-filters shall be loaded first followed by microvee filters and finally HEPA filters. AHU shall be run with each set of filters for 24 h and the conditioned area shall be cleaned and mopped each time before the next set of filters is loaded.

After air balancing, and adjusting of air quantity, a validation process shall be carried out by recording temperature, humidity and pressure differentials. For critical areas, validation process shall be repeated and recorded at least once every year.

8.1.2 Data Centre

8.1.2.1 Data centre is a technological facility which houses electronic equipment used for data processing, storing and networking (datacom equipment). The design requirement for cooling of such technological facility differs significantly from comfort air conditioners.

Such facility has a little or no requirement of occupancy as the facility becomes complete automatic barring interventions for maintenance. The major contributing heat is from electronic equipment which is sensible in nature and hence cooling equipment needs to be designed with a high sensible factor. Main focus is equipment cooling rather than comfort conditions for space.

The facility generally works for all day and all night (continuously 24×7). High reliability and redundancy is an important criteria as any loss of data may contribute to huge financial loss. The components to be selected for cooling datacom equipment need to be highly reliable besides being energy efficient.

8.1.2.2 Inside conditions/thermal guidelines

Inside temperature within the facility may vary depending on whether dehumidified conditioned air is supplied on inlet side or exhaust side of the equipment. Presently the best practice of facility design for datacom equipment placement in the rack is based on hot and

cold aisle air arrangement. In such configuration, front of the datacom equipment cabinet/rack should face cold aisle, where the dehumidified conditioned air from cooling equipment is supplied either through floor grilles or through overhead ducts.

The allowable envelope is where information technology (IT) manufactures test their equipment in order to verify that the equipment will function within these envelope boundaries.

Prolonged exposure of IT equipment to conditions outside its recommended range, especially approaching the extremes of the allowable environment, can result in decreased equipment reliability and shorter life span. However, occasional short time excursions outside the allowable envelope, may be acceptable.

Facilities should be designed and operated to target the recommended range. The present recommended range is:

- a) Low end temperature : 18°C (64.4°F)
- b) High end temperature : 27°C (80.6°F)
- c) Low end moisture : 5.5°C DP
(41.9°F DP)
- d) High end moisture : 60 percent RH and
15°C DP (59°F DP)

8.1.3 Underground Metro Station

The underground metro station is provided with environment control system (ECS). The ECS system shall serve following function:

- a) Station public area and ancillary room air conditioning,
- b) Mechanical ventilation of plant rooms, and
- c) Smoke management system.

8.1.3.1 Station public area and ancillary room air conditioning

8.1.3.1.1 Station air conditioning design philosophy

The underground stations of the metro corridor are built in a confined space. A large number of passengers occupy concourse halls and the platforms, especially at the peak hours. It is therefore, essential to provide forced ventilation in the stations for the purpose of,

- a) supplying fresh air for the physiological needs of passengers and the authority's staff;
- b) removing body heat, obnoxious odours and harmful gases like carbon dioxide exhaled during breathing;
- c) preventing concentration of moisture generated by body sweat and seepage of water in the sub-way; and
- d) removing large quantity of heat dissipated by the train equipment like traction motors,

braking units, compressors mounted below the under-frame, lights and fans inside the coaches and the air conditioning units.

8.1.3.1.2 Station heat load

The station heat loads are a combination of the unsteady train heat loads, passenger heat load, lighting, equipment, miscellaneous equipment and fresh air loads, as given below:

- a) *Unsteady heat load due to train movement* — The major source of heat for the station is from the train air conditioning systems and the train traction and braking systems.

The heat developed inside the tunnel during normal operation mixes with station air due to piston effect caused by train movement. This increases heat load of the station. This heat load is unsteady and needs special software for its estimation. These software model the complete metro network of tunnels and underground station and take train operation, rolling stock physical parameter, tunnel structure parameters, tunnel gradient and alignment, station architecture, etc, as input data. Such software takes into account the heat load of tunnel airflow generated by the train movement and the heat of trains dwelling at station as per the planned headway of train operation. These values do not include the fresh air heat loads or the steady heat loads from station, such as passengers, lighting, escalator and other equipment.

The unsteady heat load is obtained from the software at simultaneous and staggered headway for summer and monsoon condition, and the system is designed for the highest heat load.

- b) *Steady heat load:*
- 1) *Passenger heat load* — The passenger occupancy at station is taken from Peak Hour Peak Direction Traffic (PHPDT) data given in detail project report (DPR). Passenger heat gain shall be computed from the above data.
 - 2) *Lighting and miscellaneous equipment load* — It is based on lighting in public area and equipment like lifts, escalators and AFC Gates contributing to the heat load.
 - 3) *Fresh air loads* — Fresh air is supplied to the platform and concourse to meet the physiological requirements of the passengers. Fresh air quantity is considered as 10 percent of supply air

quantity, or at the rate of $0.005 \text{ m}^3/\text{s.m}^2$, whichever is higher.

8.1.3.1.3 Design criteria

Since the passengers stay in the stations only for a short period, a reasonable degree of comfort conditions, just short of discomfort conditions are considered appropriate. Station air conditioning system shall be designed to maintain specific design conditions.

Station air conditioning system design conditions are:

- a) Platform, concourse : 27°C at 55 percent relative humidity
- b) Outdoor : Summer and monsoon condition as per location

8.1.3.1.4 System description

The station environment control shall be by a central air conditioning system. Station shall have provision of fresh air intake and exhaust shaft. The station shall be supplied with conditioned air *via* ductwork from air handling unit (AHU) located in plant room. AHU shall be supplied with chilled water from water cooled chillers and its associated pumping system.

To extract the return air, trackway exhaust system shall be installed in the trainways of each station to capture both excessive tunnel airflows and the heat rejected by the vehicle propulsion/braking/air-conditioning systems as the train dwells in the station. An under platform exhaust (UPE) duct is often utilized to capture heat from the trains undercarriage heat sources. An overtrack exhaust duct is normally utilized to capture heat that is rejected from the above car area of dwelling trains. The overhead trackway exhaust (OTE) duct may be required if the railcars have rooftop mounted air-conditioning units. Openings in the OTE and UPE shall be located so as to be near the heat generating sources on the train.

8.1.3.1.5 Modes of operation

- a) *Open mode operation* — In open mode, 100 percent outside air is circulated in the stations. It is an economical mode of operation when the outside air temperature is relatively low. AHU shall draw the air directly from outside *via* fresh air shaft and deliver the air at platform level and concourse level. Trackway exhaust fans (TEF) shall extract the air from OTE and UPE and discharge it outside directly *via* exhaust shaft. The water cooled chillers units shall remain shut down in this mode. This mode is generally used during winter season.
- b) *Closed mode operation* — In close mode, air

is extracted from the public areas of the station and returned to the air handling units to be cooled and delivered back to the platform and concourse. Closed mode operation is proposed when the outside air temperature and humidity are high. In this operation, AHU shall recirculate the air of OTE and UPE with the addition of 10 percent fresh air, brought in by fresh air fans (FAF). The TEF will take the exhaust from OTE and UPE and deliver to return air plenum where 10 percent fresh air is also mixed with the return air. This mode is generally used during summer and monsoon season.

8.1.3.2 Ancillary area air conditioning

Air conditioning of ancillary areas, that are occupied by staff and non-travelling persons, who are going to stay in these areas for considerable duration, is carried out by system similar to that for normal buildings.

8.1.3.3 Mechanical ventilation

The backs of house area rooms are provided with mechanical ventilation supply, ventilation exhaust or both according to their use and particular requirements.

8.1.3.4 Smoke management system

The smoke extract fans (SEF) and trackway exhaust fans (TEF) are used respectively for concourse and platform smoke extraction. The smoke extraction fans and other system components like duct, dampers, attenuators, etc, shall have suitable fire rating. Smoke extraction fans with related equipment shall be installed in the ECS plant rooms provided at concourse level at each end of the station. Where smoke extract ducting passes through protected areas, it shall be rated to the same fire resistance as the walls of the compartments. Flow switches shall be provided for exhaust. Station smoke removal fans to provide a positive indication of the fan operation at the station control rooms (SCR) as well as operations control center (OCC).

8.1.3.5 Staircase pressurization

Pressurization of exits shall be done in accordance with Part 4 'Fire and Life Safety' of the Code.

9 REFRIGERATION FOR COLD STORES

Cold store plays a major and critical role in cold chain. Apart from required temperature and relative humidity management, better air movement around the produce, proper arrangement of stacking, inspecting for any defectives are also important to maintain the produce quality in cold storage. The two basic product groups on cold storage of perishable food stuffs are chilled food and frozen food. The material of the equipment/

machineries used in cold stores should be corrosion resistant property and easily accessible for maintenance.

9.1 Key Elements and Components of Cold Room

9.1.1 Product Quality

Refrigeration cannot improve the quality of products. It does slow down the processes of microbial, chemical or enzymatic deterioration that occur in them. The more advanced these processes are, the more difficult it is to slow them down. Good results can, therefore be, expected only with clean, wholesome products which are free of any bruises, contamination or physiological disorders, and which have a normal microbial population for the products.

Storing products which do not have these qualities can harm those that do, when they are stored in the same room. They can also contaminate the rooms in which they are put together, through odours, dispersal of mold spores, etc. It shall be kept in mind that harmful micro-organism development can begin after a certain length of time and then speed up considerably. It is often very useful to know exactly where the product has come from and its history, in order to better evaluate its long term keeping quality, from both a qualitative and a commercial point of view.

Cold treatment should come quickly; that is, it should be done as soon as possible after the raw products have been harvested. Any delay in storing a product reduces the amount of time it can be stored, either because it has already deteriorated, or because it has already been transformed, and putting it into cold storage may not keep it from deteriorating further. Refrigeration should be continuous.

9.1.2 Temperature of Cold Room

During the entire storage period, the temperature should remain as constant as possible. Some products are particularly sensitive to temperature variations, which can reduce the shelf life of some fruits.

One shall avoid putting into a room a large amount of goods at a temperature too different from that of goods already in the room. The cold-production equipment should be checked to make sure it can handle this extra load. Within one room the temperature should be as uniform as possible, as this affects not just products that are sensitive to temperature variations, but also those with recommended temperatures near 0°C. These optimum conditions shall be approachable without risk of freezing.

Heat coming in through the floor and the walls can upset this uniformity of temperature in the room. However, the inside temperature can be made uniform through

forced air circulation. Dead zones and regular drafts shall be avoided. The range of temperature given in chilling is generally meant as acceptable tolerance for each food. Storage temperature shall in any case be kept as constant as possible. Temperature sensors should be placed around the room on the basis of the accuracy, as indicated by the manufacturer, of the automatic devices. Cold store temperature can be either recorded or read at regular intervals. Thermometers should be protected from impact and yet be easily accessible. Temperature should be read at more than one location. Moreover, the temperature of the products themselves should be taken.

9.1.3 Measurement of Temperature of Food

A thermometer/temperature measurement device that can measure the internal temperature of food, like one with a probe that can be inserted into the food is required. Food internal temperature needs to be measured as the surface temperature may be warmer or cooler than the temperature of the rest of the food. The thermometer shall be accurate to $\pm 0.5^{\circ}\text{C}$. The thermometer/temperature measurement device should be cleaned and sanitized before inserting it into food. The probe should be washed in warm water and detergent, sanitized according to the sanitizer instructions or the instructions that thermometer accompanies, and the probe should be allowed to air dry or thoroughly dried with a disposable towel.

9.2 Typical Design Inputs for a Standard Cold Room

The criteria involved in designing a cold room are similar to any warehouse, that is, storage capacity, facilities for receiving and dispatching goods, interior operating space, location of cold room, selection and location of refrigeration units. While designing cold room, the difference between room temperature and product temperature should be kept at a minimum value.

9.3 Importance of Heat Loads

Refrigeration load includes,

- a) transmission load, which is heat transferred into the refrigerated space through its surfaces;
- b) product load, which is heat removed from and produced by products when these are brought into and kept in the refrigerated space;
- c) internal load, which is heat produced by internal sources (for example, lights, electric motors, defrost mechanism and people working in the space);
- d) infiltration air load, which is heat gain associated with air entering the refrigerated space; and
- e) equipment related load.

The first four segments of load constitute the net heat load for which a refrigeration system is to be provided; the fifth segment consists of all heat gains created by the refrigerating equipment itself.

Thus, net heat load plus equipment heat load is the total refrigeration load for which a compressor shall be selected.

While other loads are quite similar to loads in regular HVAC system design, the product load includes the primary refrigeration loads from products brought into and kept in the refrigerated space, which includes,

- 1) heat that shall be removed to bring products to storage temperature, and
- 2) heat generated by products (mainly fruits and vegetables) in storage.

In addition, another new aspect in heat load is the heat from defrosting where the refrigeration coil operates at a temperature below freezing and shall be defrosted periodically, regardless of the room temperature.

In order to avoid system oversizing, and to take full advantage of load diversity, it is recommended to use the hour-by-hour load calculation or simulation method.

9.4 Considerations for Cold Room Selection

The conditions within a closed refrigerated chamber shall be maintained to preserve the stored product. This refers particularly to seasonal, short shelf life, and long-term storage.

The four major concerns for product compatibility are temperature, moisture, ethylene, and odour.

Specific considerations include,

- a) uniform temperatures as much as possible in empty condition as well as with product loaded condition;
- b) length of air blow and impingement on stored product;
- c) effect of relative humidity;
- d) effect of air movement on employees working in cold store;
- e) controlled ventilation, if necessary;
- f) product entering temperature;
- g) expected duration of storage;
- h) required product shipping temperature when leaving cold store;
- j) traffic in and out of storage area;
- k) design of storage bins; and
- m) size of food product ($L \times W \times H$) or volume.

Rack systems are mostly related to retail store

refrigeration and are not considered as part of building system.

9.5 Installation and Maintenance of Cold Room — Key Aspects

9.5.1 The conventional construction in cold stores is the insulation on walls and ceilings, and finishing with cement sand plaster. The latest trend is to use sheet metal cladding. The cladding materials are aluminium sheet or pre-coated galvanized steel sheet.

The development of pre-insulated panels has brought in a change in cold storage construction. Polyurethane foam (PUF) panels using polyurethane as insulation material foamed between two metal skins, are structurally strong and have a better insulation value as compared to expanded polystyrene (EPS) panels for a given thickness. All panels for thermal insulation of cold storage shall be selected and designed in accordance with the good practice [8-3(11)].

The highlights of prefab panel's construction are:

- a) Greater flexibility and faster construction due to reduced site work;
- b) Better thermal efficiency due to better isolation between outside and inside surfaces;
- c) Less moisture load due to good vapour barrier by PUF and sheet skin;
- d) Prefab panels serve as walls and ceilings, eliminating brick walls, thereby increasing the cold store volume on a given floor area;
- e) Modular construction is flexible and offers advantages of modular addition or expansion as per requirement; and
- f) Increased hygienic quality of the structures. Panels can have a finish as per user's specification and are easy to clean and maintain.

9.5.2 Refrigeration system has to be assembled as per proper specifications to ensure that refrigerant leakage does not occur. It is essential to have proper emergency measures in case of any accidental leaks. The building structure has to be designed with adequate safety factors and the thermal insulation has to be protected properly from any possible occurrence of fire. Emergency alarms should be provided in the cold store with switches in each chamber.

Safety is critical in the design, construction and operation of refrigeration systems for cold storage, especially with ammonia systems. Refrigeration system's safety standards shall meet requirements relating to safe design, construction, installation, and

operation of refrigeration systems by establishing safeguards for life, limb, health and property as per the applicable safety standards. This includes, but is not limited to, occupancy classification, restriction on refrigerant use, installation restrictions, design and construction of equipment and systems, and operation and testing. Equipment selection and their placement should be such so as to ensure safe and easy maintenance. A safety review of the engineered design and equipment layout is recommended with participation from the owner's site operations and maintenance (O&M) team. Personnel safety measures are required as part of the facility design. The designer should prepare a system safety plan with full hazard analysis.

9.6 Cold Room Safety

The cold temperatures inside a low temperature cold room can cause increase in blood viscosity and risk to life unless proper precautions are taken. A hooter should be installed outside the cold room, powered through a UPS and the switch should be fixed prominently and within reach, inside the cold room. This will help any person trapped inside to alert those outside, for help.

9.6.1 The following safety provisions should be kept/taken care of, at the cold room site:

- a) Fire fighting equipment,
- b) Safe handling of refrigerant leaks,
- c) Safety devices, controls and alarm systems,
- d) Emergency lighting in the cold chambers,
- e) Lightning arrestor,
- f) First-aid kit,
- g) Air filters/breathers,
- h) Emergency assembly points,
- j) Regular safety drills and training,
- k) Water shower in ammonia plants, and
- m) Avoiding ramps as they become slippery when wet or frozen.

9.6.2 Precautions against Getting Trapped in Freezing Room

In order to facilitate getting out of a person who may accidentally get locked in a cold room, emergency exits shall be provided. These shall have facility to be opened from inside, even when they are locked from the outside. In all cases, following shall be installed in the freezing room:

- a) Doors which can open manually both from the inside and the outside (for functioning during power shortages, etc). In case of rooms with large dimensions say more than 25 m, it is advisable to provide emergency doors with

UPS/battery lit exit sign at both ends of the freezing room for easy exit.

- b) A signage system outside the freezing room with a steady or blinking light, and a siren or buzzer, activated from the inside by pressing a UPS-lit button. This button should also be connected to the caretaker’s apartment, where a monitoring board shows where the button has been pressed. These visible and audible alarms should always be connected to a self-contained electric circuit, operated with a permanently charged battery. The same circuit should also connect to an independent, battery operated emergency lighting system or a phosphorescent signalling system, all the way to the nearest emergency exit from the area.
- c) Electric or pneumatic sliding doors, capable of being operated both from outside and inside by push button or pull cords, easily accessible, in case of large freezing rooms, to the persons inside/outside.

9.6.3 Precautions Against Refrigerant Leaks

Safety measures should be taken against leak of liquid or gaseous refrigerant. Consideration should also be given to installing gas detectors and shut-off valves. The safety of the people should be considered by installing in traffic and public areas with which the refrigerant supply can be cut long before the refrigerant concentration reaches the level which would affect the people or the stored products. The gaskets around the cold storage door should be periodically inspected and corrected for any damage.

In refrigeration applications with ammonia, there is a risk of a high concentration accumulating in an enclosed room. With 15 to 28 percent by volume, and an ignition source (of 582°C), it is possible to create a fast burning process which could be something like an explosion. So a rapid dilution/containment system or an expulsion system should be installed.

Self-contained breathing apparatuses and protective clothing are essential for entering a building with a concentration of ammonia greater than 50 ppm. Ammonia clouds can be neutralized with dry ice (CO₂) or transformed by fog nozzle, but there is then a risk of water pollution. For safety requirements for cold stores as also for refrigerant gas related safety, relevant standards shall be followed.

9.7 Cold Room in Various Segments and Requirements

The recommended temperature ranges for various applications/product categories to be stored in modular

cold rooms are given below:

<i>Application/Product category</i>	<i>Recommended Temperature Range</i>
Horticulture (fruits and vegetables)	+2 to +8°C
Floriculture	+2 to +6°C
Hotels, restaurants, fast food chains	+2 to +6°C
Pharmaceuticals	+8 to -25°C
Dairy	+8 to -25°C
Ice cream	-20 to -25°C
Ripening	+12 to +20°C
Controlled atmosphere	+1 to +3°C

requirements and other conditions. The relative humidity in most of the cases are above 90 percent except pharmaceuticals, seeds and frozen products, or as required for a specific case by the user.

10 HEATING

10.1 The installations for air conditioning system may be used advantageously for the central heating system with additions such as a hot water and hot water coil or a strip heater bank. Electrical heating may be actively discouraged and instead heating through superheat of cooling unit, heat pump, reverse cycle operation of unitary system and solar hot water systems are highly desirable; these result in a greener environment and lower carbon foot print.

While the efficiency of a heating equipment can never be more than 100 percent, a refrigeration system for heating usage can have the coefficient of performance (COP) of more than 4.5. Therefore, compared to electrical heating or thermal heating through boiler, preference should be for the systems working on refrigeration principle. Some examples are heat pump, VEF system, air cooled package unit, split air conditioner (in reverse cycle mode), and even window air-conditioner (in reverse cycle mode). Any of these refrigeration system can result in considerable energy saving and lesser carbon print. Hence while purchasing an air conditioner, a better choice can be for models with both cooling-heating modes.

10.2 Various heating equipment/systems are described under **10.2.1** to **10.2.6**.

10.2.1 Hot Water Heated Coils

Central heating systems using hot water usually require not more than one or two rows of tubes in the direction of air flow, in order to produce the desired heating capacity. To achieve high efficiency without excessive water pressure drop through the coil, various circuit arrangements are adopted.

Generally, the resistance to the hot water flow through the heating coil should not exceed 4 kPa in low pressure

hot water heating installations. In high pressure hot water installations, the resistance to the water flow will probably be determined by other factors, for example, the need to balance circuits.

The hot water heating coil should be served from hot water supply and return mains with sufficient connections to each row, or bank of tubes, or sections, to give uniform distribution of the heating medium.

The hot water supply connection to the heating coil should generally be arranged at the lowest point, and the return connections at the highest, to aid venting. The expansion of the tubes when the heating coil is in operation should be considered, and necessary arrangement made to accommodate expansion and contraction.

Thermometer wells should be fitted in the pipes near the inlet and outlet of the coil so that the temperature drop through the heating coil can be readily observed.

10.2.2 Electric Heating

Air velocity through electric heating element should be sufficient to permit the absorption of the rated output of the finned tube heaters within its range of safe temperatures. Exact velocity determined in conjunction with the manufacturers of the heating elements. Electrical load should be balanced across the three phases of the power supply.

Where automatic temperature control is required, the electric heating element should be divided into a number of sections, depending upon the degree of control to be effected.

Each section of the heating element, which may be two rows of elements, should have its own bus bar and connections. Each section should be capable of withdrawal from the casing, thus enabling parts of the elements to be cleaned or repaired, whilst the remaining elements continue in operation. Each section should be capable of being isolated electrically before being withdrawn from the casing.

All electric heating elements should be electrically interlocked with the fan motor(s), so that the electric supply to the heating elements gets switched off when the fan is stopped, or when air velocity is reduced to a level below that for which the heating element has been designed.

The air velocity over the face of the heating element is of particular importance in the design of electric heating, and the manufacturer should be given details of the maximum and minimum air velocities likely to occur.

With all electric heating, care should be taken to preclude the risk of fire under abnormal conditions of

operation, by the use of a suitably positioned temperature sensitive trip of the manual reset type, to cut off the electric supply in case of temperature rise beyond the specified limit.

10.2.3 Solar Water Heating (SWH) System

SWH is the conversion of sunlight into renewable energy for water heating using a solar thermal collector. In a close-coupled SWH system, the hot water storage tank is horizontally mounted immediately above the solar collectors on the roof. No pumping is required as the hot water naturally rises into the tank through thermal siphon flow. In a pump circulated system, the storage tank is ground or floor mounted and is below the level of the collectors; a circulating pump moves water or heat transfer fluid between the tank and the collectors.

SWH systems are designed to deliver hot water for most times of the year. However, in winter, sometimes there may not be sufficient solar heat gain to deliver sufficient hot water. Therefore, a gas or electric booster is used to heat the water.

Residential solar thermal installations fall into two groups; passive systems (sometimes called compact) and active systems (sometimes called pumped). Both typically include an auxiliary energy source (electric heating element or gas connection for the hot water storage tank, or fuel oil fired central heating system) which is activated when the water in the tank falls below a minimum temperature setting such as 55°C. Hence, hot water is always available. The combination of solar water heating and using the back-up heat from boiler to heat water can enable a hot water system to work all year round in cooler climates.

The amount of heat delivered by a solar water heating system depends primarily on the amount of heat delivered by the sun at a particular place, that is, the insolation. In tropical places, the insolation can be relatively high, for example, 7 kWh/m² per day, whereas the insolation can be much lower in temperate areas where the days are shorter in winter, for example, 3.2 kWh/m² per day. Even at the same latitude the average insolation can vary a great deal from location to location due to differences in local weather patterns and the amount of overcast.

The design, installation and performance evaluation of solar heating systems shall be in accordance with the good practice [8-3(12)].

10.2.4 Condenser Heat Recovery System

Condenser heat recovery system captures energy that would otherwise be wasted to the atmosphere and converts this energy into useful heat. It is possible to capture this heat from the condenser and use it to

generate hot water. By capturing this heat, overall system efficiency is considerably improved. Such a system should be used, wherever there is heating requirement concurrent with cooling demand.

10.2.5 Heat Pump

Heat pump can provide year round climate control by supplying heat in the winter and cooling it in the summer. Some types can also heat water. A heat pump is an electrical device that extracts heat from one place and transfers it to another. Air sourced heat pumps draw heat from the outside air during the winter heating season, and rejects heat outside during the summer cooling season. There are two types of air source heat pumps. The most common is the air-to-air heat pump. It extracts heat from the air and then transfers heat to either the inside or outside depending on the season. The other type is the air-to-water heat pump, which is used with hydronic heat distribution systems. During heating, in the winter season, the heat pump takes heat from the outside air and then transfers it to the water in the hydronic distribution system. During cooling, in the summer season, the process is reversed: heat pump extracts heat from water in the home's distribution system and pumps it outside to cool. Electricity is used to pump a refrigerant around the system, which picks up heat from the air and transfers it to the water/air.

Efficiency of heat pump is significantly higher as compared to gas or electric heater and when used in the right environment, results in energy saving, economy and also reduce greenhouse gas emissions

A heat pump uses electricity to drive the compressor and the fan instead of using electricity to heat the water directly. The amount of heat transferred depends on the ambient temperature. For example, when air temperature is 15°C and the desired water temperature is 55 to 60°C, the heat transferred into the water is typically around 3 times as much as the electrical energy used. Heat pumps may require an electric booster, if operated in regions where it is cold. The electric boost turns on once the entering water temperature drops below a certain point (normally below 15°C).

Selection of heat pump as a heating system over all other available options, would depend on the particular circumstances. In addition, placement and manner of installation of the hot water appliance can have a significant effect on the running costs and life span of the system. The important considerations to be kept in view while selecting a heat pump hot water heater are given hereunder.

Heat pump works most efficiently in warm, humid climates. It can work effectively during the night and in wet weather provided the air temperature is sufficient. Some models can continue to operate to temperatures

below 0°C, though they will not achieve a very high level of efficiency. Heat pumps operate most efficiently at higher air temperatures. Heat pumps can be a better choice than solar water heaters for locations with limited sunshine, provided that the temperatures are not consistently low. In locations with good year round sunshine, a solar water heater that requires little boosting could use less energy.

10.2.6 Ground Source Heat Pump

Ground source heat pump uses the earth, or ground water, or both as the source of heat in the winter, and as the sink for heat removed from the conditioned areas in the summer. Heat is removed from the earth by using groundwater or an antifreeze solution; the liquid's temperature is raised by the heat pump; and the heat is transferred to indoor air. For year round air conditioning, the process is reversed during summer months, heat is taken from indoor air and transferred to the earth, by the ground water.

11 MECHANICAL VENTILATION

11.1 Objective and Options

Ventilation is the process of changing air in an enclosed space. A portion of the air in the space should be continuously withdrawn and replaced by fresh air drawn from outside to maintain the required level of air purity, health, comfort and safety of building occupants. Ventilation is required to control the following:

- a) *Oxygen content* — Prevent depletion of the oxygen content of the air;
- b) *Carbon dioxide and moisture* — To prevent undue accumulation;
- c) *Other hazardous gases, such as, CO, NOx, SO₂, etc* — To eliminate;
- d) *Odours and contaminants* — To prevent undue rise in concentration of body and other odours and contaminants (chemical, VOCs, tobacco smoke, etc);
- e) *Bacteria* — To oxidize colonies of bacteria and fungi to prevent their proliferation; and
- f) *Heat* — To remove body heat and heat dissipated by electrical or mechanical equipment, and solar heat gains.

Ventilation may include either mechanical exhaust system or exhaust can occur through natural means. Mechanical ventilation is one of the forms of ventilation option available. It usually consists of fans, filters, ducts, air diffusers and outlets for air distribution within the building. Natural ventilation and natural exhaust, which are another option for ventilation, are covered in Part 8 'Building Services, Section 1 Lighting and Natural Ventilation' of the

Code. The scope of this Section is therefore restricted to mechanical ventilation.

Following considerations affect the type of ventilation system selected for a particular application and sizing of the ventilation plant:

- a) The climatic zone in which the building is located is a major consideration. An important distinction that shall be made is between hot-dry and warm-moist conditions. In an industrial environment, hot dry conditions occur around furnaces, forges, metal extruding and rolling mills, glass forming machines, and so forth.
Typical warm moist conditions are found in textile mills, laundries, dye houses, and deep mines where water is used extensively for dust control. Warm-moist conditions are more hazardous than hot-dry conditions.
- b) Siting (and orientation) of a building is also an important factor. Solar heat gain and high outside temperature can add significant heat load, in addition to the internal heat gains from occupants, equipment and processes.
- c) The comfort level required is another consideration. In many industrial applications, comfort levels as understood in the context of residential buildings, commercial blocks or office establishments cannot be achieved and therefore, what is often aimed in industrial application is 'acceptable working conditions' rather than 'comfort'.

There are many options available in mechanical ventilation, such as, spot cooling, local exhaust, changes in work pattern, for achieving the desired acceptable working conditions. The options available may need to be extended to evaporative cooling in order to achieve more acceptable working conditions when confronted with more hostile environmental conditions. For meeting heat stress standards, radiation shielding in addition to ventilation control measures described above may become necessary.

As a general rule, in complex and harsher environmental situations, mechanical systems should be the preferred alternative to achieve acceptable working conditions.

11.2 Industrial Ventilation

Industrial buildings find a major application of mechanical ventilation. Industrial processes may use chemical compounds and toxic substances which may cause particulates, gases and mists in the work zone air in concentrations that cross the prescribed safe limits. Thus in industrial buildings, ventilation is needed not only to provide oxygen rich fresh air normally

required for health and hygiene and to mitigate against thermal loads due to equipment, people and building heat gains, but also to remove and maintain the hazardous industrial pollutants within safe limits.

11.2.1 Basic Ventilation Strategies

11.2.1.1 Mechanical extract/natural supply

This is the simplest form of extract strategy comprising one or more exhaust fans, usually of the propeller, axial flow or mixed flow type, installed on outside wall or on the roof. The discharge should terminate in louvers or cowls or a combination of both.

Alternatively, the system may comprise of ductwork arranged for general extraction of the vitiated air or for extraction from localized sources of heat, moisture, odours, fumes and dust. Such duct work may be connected to centrifugal or axial flow fan which discharge through the wall or roof, terminating in louvers or cowls or a combination of both.

It is essential that provision for make-up air is made and that consideration is given to the location and size of inlet. Inlet should not be located in the vicinity of exhaust fan. This strategy creates negative pressurization in the building and is not suitable for dusty ambient environment, nor when dust free environment needs to be maintained indoors.

11.2.1.2 Mechanical supply/natural extract

This strategy is similar in form to the extract strategy but arranged so that one or more fans supply fresh air into the enclosed space. Such a system necessitates the discharge of vitiated air by natural means through open doors, windows, other building openings and cracks. This ventilation strategy creates positive pressurization in the enclosed space which is essential to maintain a clean interior environment. For relatively closed spaces, positive pressurization levels can be controlled by providing balanced pressure relief dampers at selected discharge zones.

The points of delivery of fresh air supply can be controlled by incorporating a system of supply ducts and discharge diffusers. The desired level of air quality in the supply air can be maintained by providing suitable filters in the supply fan systems.

11.2.1.3 Mechanical supply/mechanical extract

This strategy is a combination of the above two strategies and consists of two independent systems — a mechanical supply system and a mechanical extract system with or without their respective duct system.

This strategy provides the best opportunity for control of ventilation parameters, such as, indoor air quality,

air distribution, movement and pressurization, but with additional system cost and complexity.

In the interest of efficient use of energy and comfort to the occupants, it is imperative that all ventilation strategies should be considered in relation to the thermal characteristics of the building, ambient environment and the nature of processes inside.

Reference shall be made to the good practice [8-3(13)] for basic requirements regarding safe design, installation, operation, testing and maintenance of ventilating system with respect to general ventilation and wherever applicable dilution ventilation for industrial processes. Measures to reduce heat hazards due to industrial processes are also briefly described therein. The information contained in this section should be considered complimentary to the good practice and shall not supersede the provisions of the same.

11.2.2 Ventilation for Heat Control

Ventilation for heat control measures normally includes cooler replacement air, an evaporative or mechanically cooled source, velocity cooling method or combination thereof. The required ventilation flow rate should be calculated both for the sensible and latent heat load. The required ventilation rate is the larger of the two volumetric flows.

In majority of cases the sensible heat load far exceeds the latent heat load, so the design rate usually can be calculated on the basis of sensible heat alone. The sensible heat load includes solar heat gain, occupancy, lighting load, equipment load as well as other particular sources, if any.

The ventilation flow rate can be calculated using the following equation:

$$Q_s = 3.462 \times \frac{H_s}{\Delta T}$$

where

Q_s = air volume flow rate, in m³/h;

H_s = sensible heat load, in kcal/h; and

ΔT = allowable temperature rise, in °C.

The allowable temperature-rise values are specified in Table 2 of the good practice [8-3(13)]. Ventilation system should be designed for air to flow through the hot environment in a manner that will effectively control the excess heat.

11.2.3 General (Dilution) Ventilation Versus Local Exhaust Ventilation

General exhaust ventilation (dilution ventilation) is appropriate when,

- a) emission sources contain materials of relatively low hazard (*see Note*);

- b) emission sources are primarily vapours or gases, or small, respirable size aerosols (those not likely to settle);
- c) emissions occur uniformly;
- d) emissions are widely dispersed;
- e) moderate climatic conditions prevail;
- f) heat is to be removed from the space by flushing it with outside air;
- g) concentrations of vapours are to be reduced in an enclosure; and
- h) portable or mobile emission sources are to be controlled.

NOTE — The degree of hazard is related to toxicity, dose rate, and individual susceptibility.

Local exhaust ventilation is appropriate when,

- 1) emission sources contain materials of relatively high hazard;
- 2) emitted materials are primarily larger diameter particulates (likely to settle);
- 3) emissions vary over time;
- 4) emission sources consist of point sources;
- 5) employees work in the immediate vicinity of the emission source;
- 6) the plant is located in a severe climate; and
- 7) minimising air turnover is necessary.

Local exhaust ventilation normally requires lower air flows than general (dilution) ventilation.

Dilution ventilation is used to reduce the concentration of vapours from a given liquid solvent in the air to a safe level known as the threshold limit value (TLV) of the solvent expressed in ppm (parts per million). For a given solvent, the volume of air required to dilute its vapour concentration to below TLV can be calculated by the following equation:

$$\text{Air volume, in m}^3 \text{ per kg of evaporation} = \frac{(24 \times 10^6 \times k)}{(m \times TLV)}$$

where

k = constant varying from 3 to 10 depending on the solvent, uniformity of air distribution, dilution of vapours in air and location of exhaust hood; and

m = molecular weight of the solvent.

A local exhaust ventilation system normally consists of a hood, a duct system, air cleaner, a fan and an exhaust stack. Such a system captures the contaminants at the point of generation through a properly mounted exhaust hood. The exhaust flow rate is determined from the area of the hood opening and capture velocity sufficient to prevent outward escapement of the

contaminant. Table 8 lists the recommended range of capture velocity for various types of industrial contaminants.

Table 8 Recommended Capture Velocities for Industrial Contaminants
(Clause 11.2.3)

Sl No.	Condition of Dispersion of Contaminant	Process Example	Recommended Capture Velocity m/s
(1)	(2)	(3)	(4)
i)	Released with practically zero velocity into still air	Evaporation from pickling tank, degreasing tank	0.25-0.5
ii)	Released at low velocity into moderately still air	Spray booth, intermittent container filling, welding, plating, low speed conveyor transfer	0.5-1.0
iii)	Active generation into zone of rapid air motion	Spray painting in shallow booth, barrel filling, conveyor loading, crushers	1.0-2.5
iv)	Released at high initial velocities into zone of very rapid air motion	Grinding, abrasive blasting, tumbling	2.5-10

From the range of capture velocities shown in the above table, the proper choice of capture velocity may be made based on the factors described in Table 9.

Table 9 Factors Affecting the Choice of Capture Velocity within a Range
(Clause 11.2.3)

Sl No.	Lower End of Range	Upper End of Range
(1)	(2)	(3)
i)	Minimum air currents favourable to capture	High room air currents
ii)	Minimum toxicity of the contaminants	High toxic contaminant
iii)	Intermittent/low production	High production/heavy use
iv)	Large hood, large air mass in motion	Small hood, local control only

The sizing of the ducts shall be determined considering the volume of air required and recommended duct velocity necessary to convey the contaminants with minimum possible pressure drop keeping in mind economics of installation and operation. Recommended duct velocity for exhaust ventilation system is given in Table 10.

The selection, installation and operation of fan should be in conformity with the nature of contaminants and should be capable of overcoming the total system pressure drop and deliver the required flow rate. For dust and other industrial contaminant laden air, the drive

arrangement (motor, belts and pulleys) should be kept outside the air stream.

Table 10 Recommended Duct Velocity for Exhaust Ventilation Systems
(Clause 11.2.3)

Sl No.	Nature of Contaminants	Examples	Recommended Duct Velocity m/s
(1)	(2)	(3)	(4)
i)	Vapours, gases, smoke	All vapours, gases and smoke	5 - 10
ii)	Fumes	Welding	10 - 12.5
iii)	Air laden with very fine dusts	Litho powder, wood flour, cotton lint	12.5 - 15
iv)	Dry dust and powders	Fine rubber dust, moulding powder dust, cotton dust, jute lint, soap dust, leather shaving	15 - 20
v)	Average industrial dusts	Grinding dust, general material handling, clay dust, brick cutting, lime stone dust, asbestos dust in textile industry, dry buffing lint, granite dust, silica flour, shoe dust	17.5 - 20
vi)	Heavy dusts	Metal turnings, saw dust, sand blast dust, C.I. boring dust, lead dust, foundry tumbling barrels and shakeout	20 - 22.5
vii)	Heavy and moist dusts	Lead dust with small clips, moist cement dust, sticky buffing lint, quick lime dust	22.5 and above

11.2.4 Humidification for Industrial Processes

Evaporative cooling should generally be used, where humidification is necessary to meet the requirements of manufacturing processes in factories, as for instance, in a cotton mill to keep the textile fibres pliable and strong, in rubber factories to prevent static electricity in processes using volatile and inflammable solvents, and in painting and lithographic works to maintain accurately the size of the paper and other materials. Evaporative cooling shall be done in accordance with 7.2.15.

11.3 General Ventilation Rate for Non Air Conditioned Areas

The rate of air circulation recommended for different general areas is as given in Table 11.

11.4 Commercial Kitchen Ventilation

The basic purpose of a kitchen ventilation system (KVS) is to provide a comfortable environment in the kitchen and to ensure the safety of the people working in the kitchen and other building occupants, by effective removal of effluents which may include gaseous, liquid and solid contaminants produced by the cooking process and products of fuel and food combustion.

Table 11 Recommended Rate of Air Circulation for Different Areas
(Clause 11.3)

Sl No. (1)	Application (2)	Air Change per Hour (3)
1)	Assembly rooms	4-8
2)	Bakeries	20-30
3)	Banks/building societies	4-8
4)	Bathrooms	6-10
5)	Bedrooms	2-4
6)	Billiard rooms	6-8
7)	Boiler rooms	see 11.2.2
8)	Cafes and coffee bars	10-12
9)	Canteens	8-12
10)	Cellars	3-10
11)	Changing rooms	6-10
12)	Churches	1-3
13)	Cinemas and theatres	10-15
14)	Club rooms	12, <i>Min</i>
15)	Compressor rooms	10-12
16)	Conference rooms	8-12
17)	Corridors	5-10
18)	Dairies	8-12
19)	Dance halls	12, <i>Min</i>
20)	Dye works	20-30
21)	Electroplating shops	10-12
22)	Engine rooms/DG rooms/GG rooms	see 11.2.2
23)	Entrance halls	3-5
24)	Factories and work shops	8-10
25)	Foundries	15-30
26)	Garages	6-8
27)	Glass houses	25-60
28)	Gymnasium	6, <i>Min</i>
29)	Hair dressing saloon	10-15
30)	Hospitals-sterilising	15-25
31)	Hospital-wards	6-8
32)	Hospital domestic	15-20
33)	Laboratories	6-15
34)	Launderettes	10-15
35)	Laundries	10-30
36)	Lavatories	6-15
37)	Lecture theatres	5-8
38)	Libraries	3-5
39)	Lift cars	20, <i>Min</i>
40)	Living rooms	3-6
41)	Mushroom houses	6-10
42)	Offices	6-10
43)	Paint shops(not cellulose)	10-20
44)	Photo and X-ray dark room	10-15
45)	Public house bars	12, <i>Min</i>
46)	Recording control rooms	15-25
47)	Recording studios	10-12
48)	Restaurants	8-12
49)	Schoolrooms	5-7
50)	Shops and supermarkets	8-15
51)	Shower baths	15-20
52)	Stores and warehouses	3-6
53)	STP rooms	30, <i>Min</i>
54)	Squash courts	4, <i>Min</i>
55)	Swimming baths	10-15
56)	Toilets	6-10
57)	Underground vehicle parking	6, <i>Min</i>
58)	Utility rooms	15-30
59)	Welding shops	15-30

Heat is the primary ingredient of kitchen effluents. 50-90

percent of the appliance energy input is released in the form of a rising convective thermal plume above the cooking surface; balance is released into the surrounding space through radiation. The thermal plume also contains most of the food and fuel generated effluents. In the absence of cross drafts, the hot convective plume above a cooking surface rises vertically, entraining ambient air which enlarges the plume, cools it and slows it down. This hot plume can be conveniently captured by placing an exhaust hood over the cooking surface. The hood shall be of sufficient size and placed at proper height to encompass the whole plume. The hood exhaust flow rate should be slightly higher than the plume flow rate. Extra exhaust capacity may be required to resist cross drafts.

From a system design perspective, grease is the most important constituent of effluent generation in a commercial kitchen. Grease generation is a function of both what is being cooked and on what type of appliance it is being cooked. The amount of grease in vapour phase is significant and varies from 30 percent to 90 percent by mass. This is an important factor in designing the grease removal system. Carbon monoxide (CO), carbon dioxide (CO₂) and oxides of nitrogen (NO_x) are present in combustion processes in gas appliances and not in electrical appliances.

11.4.1 Hood Exhaust Flow Rate

Kitchen hoods have been classified as two types, Type I and Type II. Type I hoods are used to collect and remove grease, smoke, steam and heat. Type II hoods only remove steam and heat. Thus, Type I hoods are fitted with some kind of grease collection device such as grease filters, baffles and a fire suppression system but a Type II hood typically does not have these devices. Appliances such as cooking ranges, fryers, broilers and griddles require Type I hoods whereas ovens, steamers and dishwashers can work with Type II hoods.

The most commonly used Type I hoods are available in four basic styles:

- a) Wall mounted canopy;
- b) Single island;
- c) Double island; and
- d) Back shelf or proximity.

The upward velocity of the effluent thermal currents over the hot cooking surface is mainly a function of the temperature of the cooking surface and varies from 0.08 m/s over steam equipment to 0.8 m/s over charcoal broilers. Higher the effluent velocity, higher will be the flow required. Thus for a particular hood style, the exhaust flow rate is primarily determined by the appliance surface temperature (type of appliance), in addition to an allowance for preventing cross drafts.

Recommended hood exhaust flow rates for different types of cooking equipment and exhaust hoods per linear metre of hood length should be as per Table 12.

If more than one duty category appliance is placed under one hood, the hood exhaust flow should be calculated on the basis of the heaviest duty appliance.

For Type II hoods, the recommended exhaust flow rates are from 150 to 460 litre per second per linear metre of hood length for oven hoods, and 460 to 770 litre per second for condensate hoods.

11.4.2 Good Hood Design and Installation Practices

Following are good hood design and installation practices:

- a) Increasing hood overhang increases capture volume which aids capture and prevents spillage. A minimum overhang of 150 mm on all open sides for all canopy hoods is recommended. Increasing front overhang and use of inclined side panels (instead of side overhang) significantly reduces capture flow rates.
- b) Deployment of side panels improves hood performance significantly. Side panels prevent the plume from spilling at the side, prevent cross drafts and increase velocity at the hood front.
- c) Under a wall canopy hood, pushing the appliance towards the back wall significantly improves hood performance in two ways, increased front overhang and reduction in gap between the appliance and the back wall.
- d) When using multiple duty category appliances in line under a single hood, the lowest capture

rates are achieved when light duty appliance are at the end of the line. Therefore, hood performance is best when heavy duty appliances are placed in the middle of the line.

- e) Hood should be mounted at as low a height as practical above the appliance surface.

11.4.3 Oil/Grease Removal

The removal of oil/grease from the exhaust airflow is a very important part of commercial kitchen operation. In absence of proper filtration, grease will,

- a) collect in the exhaust plenum and ducts resulting in,
 - 1) a fire hazard, and
 - 2) an increase in the frequency of costly duct cleaning;
- b) collect on the fan, causing it to become unbalanced which leads to premature failure;
- c) create odours in or near the restaurant;
- d) collect on the rooftop creating safety/ environmental hazard; and
- e) collect on the rooftop equipment and cooling coils.

These problems can be greatly reduced through the use of proper filtration device in the hood exhaust system. The design and selection of proper filtration device should ensure that the exhaust air is clean and conforms to the applicable pollution control norms.

11.4.4 Recommended Exhaust Duct Design, Installation and Maintenance Practices

Kitchen exhaust ductwork carries hot grease laden air. The following general guidelines should be followed in their design, installation and maintenance:

Table 12 Appliance Category and their Recommended Hood Exhaust Flow Rates
(Clause 11.4.1)

Sl No.	Appliance Category	Light 200°C	Medium 200°C	Heavy 315°C	Extra Heavy 370°C
(1)	(2)	(3)	(4)	(5)	(6)
i)	Cooking equipment	a) Electric/gas ovens b) Electric/gas steamers c) Cheese melters d) Pizza ovens e) Food warmers	a) Hot top/element ranges b) Griddles c) Fryers d) Pasta cookers e) Conveyor ovens f) Grill g) Rotisseries	a) Open burner ranges b) Broiler c) Wok ranges	Appliances using solid fuels for example, wood, charcoal briquettes
ii)	Plume velocity (m/s)	0.25	0.43	0.75	0.93
iii)	Hood type	Hood exhaust flow rates per linear metre of hood length litre per second			
	a) Wall mounted canopy	309	463	618	850
	b) Single island	618	772	927	1 080
	c) Double island (per side)	386	463	618	850
	d) Back shelf	463	463	618	—

- a) Ducts should be round or rectangular.
 - b) Ducts shall be grease tight and should be free of traps that can hold grease.
 - c) Minimum sheet gauge should be 16 gauge mild steel or 18 gauge stainless steel.
 - d) All joints and seams shall be fully welded and made grease tight.
 - e) Ductwork shall lead directly to building exterior and should not be interconnected with any other type of building ductwork.
 - f) Horizontal duct runs should be minimised and pitch towards the hood or an approved reservoir for continuous drainage of liquid grease and condensate. The slope should be 2 percent for runs under 23 m. For horizontal runs greater than 23 m, 8 percent slope should be provided. A grease drain outlet shall be provided in form of a leg under a vertical riser.
 - g) Maximum velocities are limited by pressure drop and noise and should normally not exceed 12.5 m/s.
 - h) The minimum air velocity for exhaust ducts should be 2.5 m/s.
 - j) For new single speed fan system, a design duct velocity of 7.5 m/s to 9 m/s is appropriate.
 - k) Ducts shall conform to requirements given in Part 4 'Fire and Life Safety' of the Code.
 - m) Access doors duly nut bolted with lead/fire rated gasket shall be provided for scavenging/grease removal during maintenance. This should be marked/provided in drawings as well as in actual duct work, so that nothing is built to block access to them.
 - n) It is recommended that duct cleaning at regular intervals be carried out so that the grease film thickness inside ducts (measured with a wet film thickness gauge or equivalent device) does not exceed 180 microns. This will avoid accidental grease sparks and fire.
- between exhaust and fresh air intake but also knowledge of prevailing winds.
 - b) grease should be collected and drained into a closed container (a fire safety precaution).
 - c) rainwater should be kept out of the grease container.
 - d) grease should not be allowed to drain down the side of the building.
 - e) discharge should not be directed downward or towards pedestrian areas.
 - f) roof top discharge should be released a minimum 4 m above the roof surface.
 - g) for discharge from building sides, it should be ensured that the discharge air is clean, free from odours and conform to applicable pollution control norms.

11.4.7 Replacement (Make-up) Air Considerations

The air exhausted through a kitchen hood shall be replaced 100 percent with clean outside air. Kitchen room pressure should be maintained slightly lower than the adjoining building space (for example, dining room) to allow conditioned air to transfer into the kitchen and to contain heat and odours within the kitchen. For kitchens adjacent to a building exterior wall, the kitchen pressure should be slightly higher than the ambient to prevent ingress of dust, heat and insects.

Replacement air in air conditioned kitchens should be supplied as close to the hood as possible and this can be best achieved by the use of compensating exhaust hoods, with supply air forming an integral part of the hood.

11.4.8 Energy Management Considerations

Hood exhaust flows can result in twenty or more air changes per hour. Installing a variable volume system is the first step towards energy conservation to allow for the exhaust and supply units to ramp up and down depending on the cooking load. Varying both the exhaust and the supply will vary the amount of air that needs to be conditioned. In some cases, a variable system can reduce the costs associated with conditioning make-up air by up to 50 percent.

Exhaust and supply air flow rates should be controlled by installing variable frequency drives (VFD) on the fan motors. The VFDs are controlled by a temperature sensor mounted in duct collar. The control system varies the frequency of the motor drives and thus fan speed, according to the temperature seen in the duct collar. The VFD system varies the flow continuously as per the cooking requirement, as opposed to the high, medium and low speed settings on the motor controlled manually. The energy savings using VFDs result from the fact that the fan power, W is proportional to the third power of speed, N , that is, $W \propto N^3$.

11.4.5 Fan for Kitchen Exhaust

Kitchen exhaust consists of hot, grease laden air with some solid particulate matter also. Fan shall be capable of handling this air and the motor and the drive train (shaft, bearings, belts, etc) shall be kept outside the air stream. The recommended kitchen exhaust fan should consist of a backward type impeller. A forward curved centrifugal fan is not recommended for kitchen exhaust.

11.4.6 Terminations of Kitchen Exhaust System

Kitchen exhaust systems should be terminated so that,

- a) discharge direction should be such as to minimise re-entry into fresh air intake. This not only requires a minimum separation

11.5 Underground Car Park Ventilation

11.5.1 Requirement

Ventilation is essential in enclosed car parking areas to dilute the level of toxic gases such as carbon monoxide (CO), oxides of nitrogen (NO_x), presence of petrol/diesel fumes and smoke from engine exhaust. Carbon monoxide is a colourless, odourless and highly poisonous gas. Even dilute concentrations of CO in air can cause nausea, headache and vertigo. The undesirable health and fire hazard of the above contaminants can be contained if their levels are maintained within permissible limits by ventilation.

The ventilation rate required to maintain the concentration of toxic gases within safe limits for an enclosed parking facility depends primarily on four factors:

- Numbers of cars in operation during peak usage (N),
- Length of time of operation* — The length of time a car remains in operation in a parking garage (T_m), which further depends on the size and layout of the garage and the number of cars trying to enter or exit. The time taken can vary from 60 s to 600 s, but on average ranges from 60 s to 180 s.
- Car emission rate* — The operation of a car in a parking garage differs considerably as compared to the car on the road or even in a road tunnel, because most of the operation of the car in and around the garage takes place at low gear. A car entering the garage is at slow speed but the engine is usually hot. A car exiting the garage has a cold engine with rich fuel mixture. Emissions from a cold start are generally much higher, so the distinction between a hot and cold start plays a critical role in determining the ventilation rate. Typical CO emissions (E) within parking garages can vary from 113 g/h (gram/hour) in summers to 202 g/h in extreme winters with hot engines. With cold start engines, the rates go up to 220 g/h in summers to as high as 1 130 g/h in winters. These rates are at an assumed vehicle speed of 8 km/h.
- Contaminant level criteria* — The recommended ventilation rate will ensure that the CO level is maintained within 40 mg/m³ (35 ppm) for 1 h exposure, with a maximum of 29 mg/m³ (25 ppm) for an 8 h exposure.

For a maximum permissible CO concentration of 29 mg/m³, the required ventilation rate, Q , in m³/h, for a given car park with number of cars in peak usage, N , may be calculated from the following equation:

$$Q = \frac{0.25N \times E \times T_m}{26.7}$$

where

- N = number of cars in peak usage;
 E = average CO emission per car, in g/h; and
 T_m = average time a car remains operating in the car park, in s.

For a parking garage of area, A , in m², and height, H , in m, the resulting air changes per hour (ACPH) may be calculated as under:

$$ACPH = \frac{Q}{(A \times H)}$$

11.5.2 Ventilation Rate Requirement of Mechanically Ventilated Underground Car Parks

For enclosed underground car parks without provision for natural ventilation, a minimum ventilation rate of 6 air changes per hour shall be provided to keep contaminants within acceptable hygiene limits. In large basements, each compartment shall be independently ventilated at the minimum rate of 6 ACPH.

11.5.3 System Requirement

The underground car park ventilation system can be classified as supply-only, exhaust-only or a combination of the two. A system of ducts or impulse fans (jet fans) may also be used for proper distribution of air in the car park. Regardless of which system is used, the following elements should be considered in planning the system:

- Accounting for the contaminant level of outside air drawn in for ventilation.
- Avoiding short circuiting supply air.
- Avoiding a long flow field that allows contaminants to exceed acceptable levels at the end of the flow field.
- Providing short flow fields in areas of high contaminant emission, thereby limiting the extent of mixing.
- Providing efficient, adequate airflow throughout the structure.
- Accounting for stratification of engine exhaust gases when stationary cars are running in enclosed facilities, for example near entry and exit.

For underground car parking, the fans and the ventilation system used for normal CO level ventilation are also used for smoke ventilation during a fire. The extraction fans, ancillaries and the system should therefore be rated for high temperature operation including air changes per hour requirement, as specified in Part 4 'Fire and Life Safety' of the Code.

11.5.4 Demand Control Ventilation Based on CO Level

The ventilation air flow rate can be varied according to CO level in order to conserve energy during off peak hours when vehicular movements is much lower than during peak hours. Since the flow rate of a fan is directly proportional to its speed, this can be achieved with multiple fans in an 'ON/OFF' mode, with dual speed motors or motors connected to variable speed drive (VFD). In multilevel basements as well as in large single level structures, independent fan system with individual control is required. This is to take care of fire compartmentation requirements (*see also* Part 4 'Fire and Life Safety' of the Code).

Significant energy savings are possible with demand control ventilation (DCV), which varies the fan speed to regulate CO levels below the maximum permissible level. The power consumed by a fan is proportional to the third power of its speed ($W \propto N^3$). This means that even, if larger fans are installed to meet code requirements, power consumption will not necessarily increase as long as demand control ventilation is used.

11.5.4.1 Location of sensors

The sensors for demand control ventilation shall be placed in the following manner:

- a) Maximum distance of any corner in the car park to the nearest sensor should be less than 25 m.
- b) Sensors should be grouped according to the zone covered by the exhaust fan. The coverage area of each sensor should typically be 500 m².
- c) Sensors should ideally be located between 0.9 m and 1.8 m above floor level. However, for practical reasons (in order to avoid vandalism), the sensors may be installed at just above 1.8 m height from floor.

11.6 Tunnel Ventilation System

11.6.1 General

The tunnel ventilation system (TVS) for underground metro station tunnel is intended to provide,

- a) an acceptable environment in the tunnel and station trackway for the operation of trains;
- b) pressure relief during normal operation;
- c) heat removal during congested/maintenance operation; and
- d) an effective means of controlling smoke flows during emergency conditions.

11.6.2 Operation Philosophies

There are three design operating conditions for the tunnel ventilation system, normal, congested and emergency.

During normal operation, the main source of ventilation for the tunnel is piston generated airflow produced by moving train. In congested operation, the tunnel ventilation fans (TVFs) are activated for preventing the accumulation of warm tunnel air around idling train in the affected ventilation zone. The tunnel ventilation design condition for congested train operation is maximum stratified tunnel air temperature of 46°C or 50°C (depends on the design of the rolling stock). In emergency operation, the TVS is set to operate to control the movement of smoke and provide a smoke-free path for evacuation of the passengers and for fire fighting purposes. The ventilation system is operated in a 'push-pull' supply and exhaust mode with jet fans or nozzles driving tunnel flows such that the smoke is forced to move in one direction, enabling evacuation to take place in the opposite direction. A typical ventilation system in tunnel during fire on a train is shown in Fig. 1.

11.6.3 System Description

The tunnel ventilation system (TVS) consists of tunnel ventilation fans (TVFs), trackway exhaust fans (TEFs), tunnel booster fans (TBFs), tunnel ventilation dampers (TVDs), nozzles and sound attenuators provided in the tunnel ventilation plant rooms at each end of the station and connected to both trackways and to outdoors through ventilation shafts.

Each tunnel ventilation installation has two fully reversible tunnel ventilation fans with fan isolation dampers. These dampers are closed when the fan is not in operation. In addition, there is a bypass duct around the fan room, which acts as a pressure relief shaft when open during normal conditions, and enables the flow of air to bypass the TVFs, allowing air exchange between tunnel with flows generated by train movement. Dampers are also used to close the connections to tunnel and nozzles when under different operating conditions. The tunnel booster fans are installed at the crossover locations to direct the flow in desired direction during congestion and emergency ventilation. The trackway exhaust fans are located in separate plant rooms at each end of the station and connected to station trackway through under platform exhaust and over track exhaust ducts and to the outdoors through exhaust ventilation shafts, to enable independent ventilation of station trackway. The specialized software tools are used to derive the TVF airflow rate, TBF thrust and location and operation philosophy to be adopted to meet the design criteria of the above mentioned scenario. In addition to this, 3D modelling tools are used to study the temperature stratification in congestion mode.

A typical schematic of the TVS system installed at Delhi metro station at platform level is shown in Fig. 2.

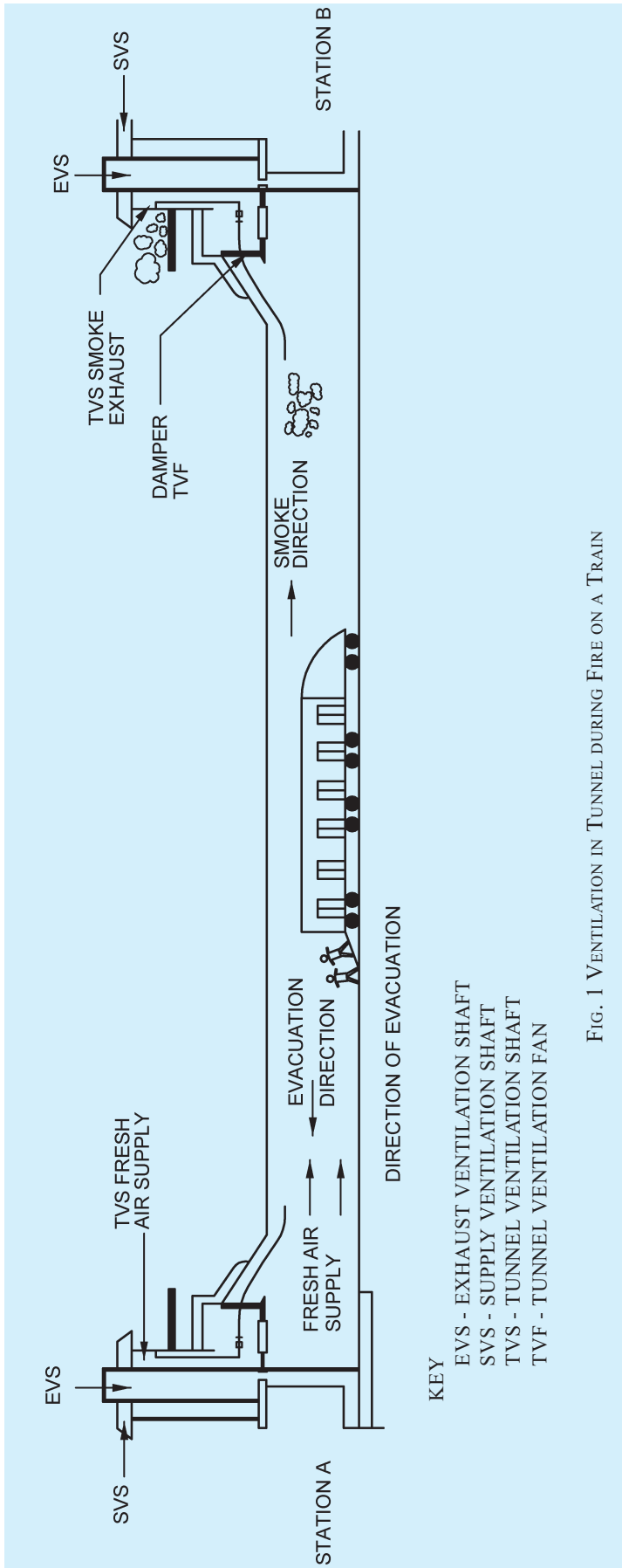

FIG. 1 VENTILATION IN TUNNEL DURING FIRE ON A TRAIN

11.6.4 Control and Monitoring of TVS

The TVS system shall be equipped with provisions for automatic, manual, local and remote controls so that the fans and motors can be operated from a station control room (SCR) or from the operations control centre (OCC). At OCC, an integrated supervisory control and data acquisition system (SCADA), should be employed to control and monitor the TVS plant in each station, as the same are generally not attended locally.

11.7 Selection of Fan for Mechanical Ventilation

Fan consumes most of the energy in a mechanical ventilation system. Various type of fans are available for ventilation applications, for example, forward and backward curved centrifugal fan, tube axial/vane axial fan, mixed flow fan, roof ventilator and in-line fans. Proper selection and application of fan for a given application results in the most economic and energy efficient operation.

The primary factors that govern the size and type of fan are the required flow, system pressure drop and acceptable noise levels. The size of the fan and its operating speed should be selected on the basis of the fan operating efficiency criterion. A fan should be selected so that its efficiency at the required point of operation is the highest possible from a range of selections. This will not only ensure minimum motor power and low energy cost but will also normally result in the quietest operation. This is because most fans emit

minimum sound levels in the vicinity of the maximum efficiency operating point.

11.7.1 Fan Efficiency Requirement

Fan total efficiency is defined as under:

$$\text{Fan total efficiency} = \frac{\text{Flow rate (m}^3/\text{s)} \times \text{Fan total pressure (Pa)}}{\text{Fan shaft power (W)}}$$

Fans are classified under various efficiency grade (FEG) based on their peak efficiency (see Fig. 3). The FEG grading is representative of the fact that larger size fan is inherently more efficient than geometrically similar smaller fan. The following selection criterion should be used to select fan for various type of mechanical ventilation applications for a new building:

- a) For axial fans requiring a shaft power of 2.5 kW or more, the fan efficiency grade shall be FEG 60 or more.
- b) For centrifugal fans requiring a shaft power of 2.5 kW or more, the fan efficiency grade shall be FEG 71 or more.

The minimum operating total efficiency of the selected fan at the desired point of operation for a given application shall be within 10 percentage points of its peak total efficiency value.

11.7.2 Other Fan Selection Parameters

In addition to the size and operating speed, the choice of a fan and its drive arrangement also depends on the

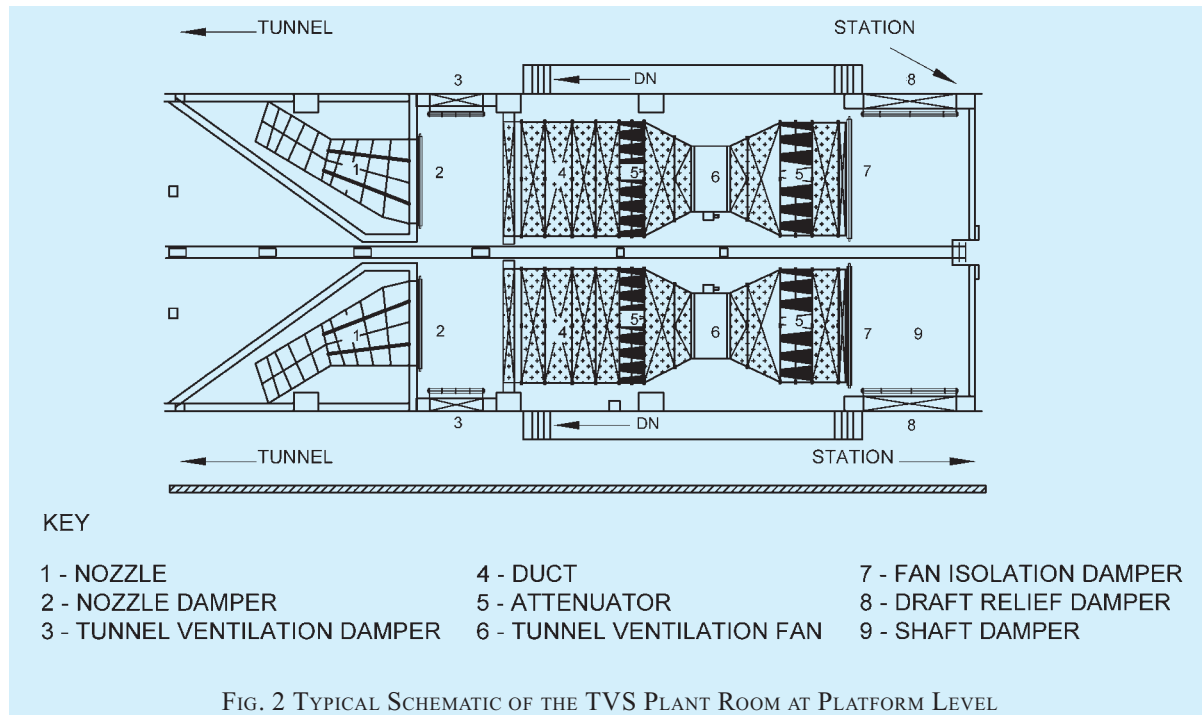

FIG. 2 TYPICAL SCHEMATIC OF THE TVS PLANT ROOM AT PLATFORM LEVEL

nature of air to be handled and the type of application. If the fan has to handle dust laden or contaminated air, for example, industrial exhaust or kitchen exhaust, the fan drive arrangement (motor, pulleys, bearing and belts) shall be kept outside the air stream. The same applies to the temperature of air to be handled. For higher than normal air temperatures, for example, smoke ventilation, the fan shall be rated for high temperature application.

Because belt drives incur additional transmission losses, consideration should also be given to direct driven fan in conjunction with variable speed drive (VFD) to adjust fan speeds.

12 INSTALLATION OF HVAC SYSTEM

12.1 Installation of Air Conditioning System

12.1.1 Installation of Chiller

The chiller shall be mounted on a reinforced cement concrete/structural foundation and shall be adequately isolated as per manufacturer’s recommendations against transmission of vibration to the building structure.

For open type, special attention shall be paid to the alignment of the drive and driven shaft; final alignment shall be checked at site in presence of the contractor, using a dial indicator.

Compressor and motor sole plates, anchor bolts, sleeves

and necessary vibration isolation pads shall be provided with the chiller.

All controls and switch gear shall be tested for proper functioning and set at design values. These shall be mounted within a panel, installed so as to permit enough space to move around the machine, and to freely operate the door of panel.

12.1.2 Installation of Pump

The pump base frame shall be mounted on concrete block which in turn shall be mounted on machinery isolation cork or any other equivalent isolation material. More than one pump set shall not be installed on a single base or on a single cement concrete block.

Foundation bolts where required, shall be embedded correctly. Before the bolts are grouted and the coupling bolted, the base frame level shall be checked before proceeding with work.

The pump motor shall then be mounted on base frame, alignment checked, and shall then be connected to the pump with flexible coupling and with guard, both for the condenser and chilled water pumps.

The insulation for chilled water pump shall be carried out in a manner so that it allow maintenance of the pump without causing damage to the insulation.

After installation of the complete system and before

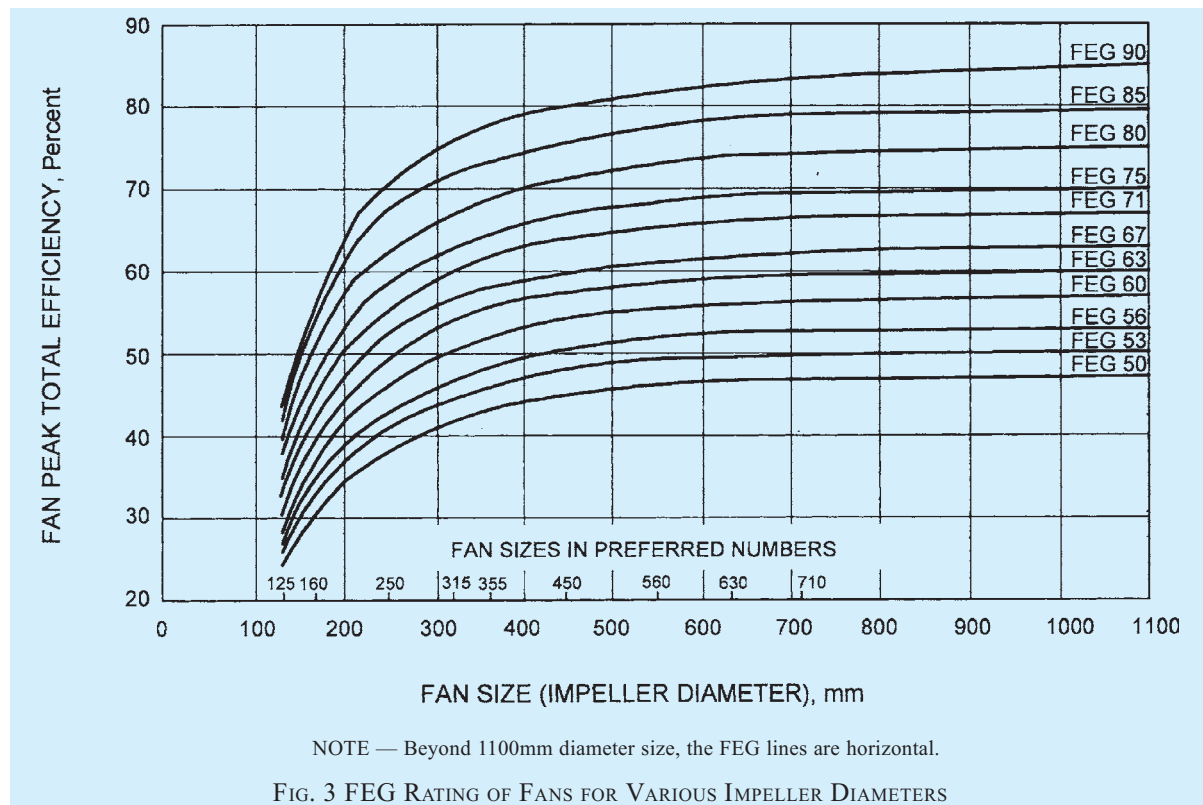

testing, the pump shall be lubricated in strict accordance with the manufacturer's instructions.

12.1.3 Installation of Cooling Tower

The cooling tower shall be mounted on a set of four or six numbers of reinforced cement concrete pillars (structural foundation) as per manufacturer's recommendations. Height of these pillars shall be not less than 1 000 mm, actual height is decided at site as per space required to install a pot strainer below the water level in cooling tower sump, drain pipe and valve for complete drainage of sump, and to permit maintenance of slab upon which structural foundation is installed.

Cooling tower should be located at a well-ventilated place, preferably on the terrace of the building, in consultation with the structural consultant. Dynamic structural loading on the terrace shall be considered. Cooling tower shall be installed in such a way that its dynamic load is transferred directly to the building structural columns, for which necessary mild steel I-section may have to be provided. Epoxy coating is required for these mild steel I-sections. Suitable thickness of vibration isolation pads shall be placed between the tower and the I-sections to avoid transfer of vibration to building structure. Sufficient space shall be left all around the cooling tower support structure for efficient operation of the cooling tower.

When cooling tower is installed at ground level, contiguous to the utility services block, great care has to be exercised to prevent users and visitors from coming in close proximity to the cooling tower. This is necessary to avoid their exposure to legionellae bacteria which can hibernate in the cooling tower sump, if operator does not follow strict instructions for regular bleed-off and chemical treatment of condenser water.

12.1.4 Installation of Air Handling Unit (AHU)

12.1.4.1 Floor mounted air handling unit is generally installed on a set of precast PCC blocks to raise it off the mounting surface to permit easy drainage of the AHU drain pan and cleaning of the mounting surface. A set of 4 or 6 numbers of 200 mm × 200 mm × 200 mm blocks are generally used for AHUs up to capacity of 10 000 m³/h air-flow, and 6 or more 300 mm × 300 mm × 300 mm blocks for higher capacity AHU.

It is essential to provide floor trap in the AHU room for disposal of condensate which accumulates in the drain pan during operation of AHU. AHU room floor should slope in the direction of floor trap to avoid the accumulation of water in AHU room. Also the slope of the drain pan should be checked in the direction of drain pipe connection, to ensure zero retention in the drain

pan, precluding possibility of legionellae bacteria hibernation. The condensate drain piping shall be connected with U-trap of the floor drain to avoid odour carry over with the return air.

AHU location shall be marked on the AHU floor as per approved shop drawings/manufacturer's details. Co-ordination with contractors for civil works and other services shall be checked prior to installation. AHU shall be assembled at site and installed on vibration isolation pad placed upon each PCC block, as per manufacturer's recommendations against transmission of vibration from AHU to the building structure (*see also 12.6*).

Easy accesses and sufficient clearance shall be ensured for servicing and maintenance, that is, for cleaning of filters, maintenance of strainer/valve packages, tightening of fan belts, and repair as well as possible replacement of fan motor.

Duct flexible connection made of fire-proof canvas, shall be fixed on air outlet of the AHU, and if possible also in perpendicular direction in main ducts within AHU room, to avoid vibration transmission along the ducts beyond the AHU room.

The valve package and piping connections shall be completed as per approved shop drawings.

12.1.4.2 Installation of ceiling suspended air handling unit shall be done with rod and fasteners as per the procedure stated above, barring the PCC blocks required for floor mounted AHU, and that insulated condensate drain pipe shall be laid in slope within ceiling space terminating into the U-trap of the nearest floor drain.

12.1.4.3 Since the AHUs have the tendency to vibrate, both floor mounted and ceiling suspended AHUs shall be isolated from the structure by suitable rubber or spring based isolators (*see 12.6*).

12.1.5 Installation of Air Washer Unit (AWU)

Air washer unit (AWU) components are similar to those of AHU, except for water spray section with in-line recirculation pump, which replaces the cooling coil. Installation of AWU shall follow the same steps as described above for AHU. Ceiling suspended AWU is not recommended.

12.1.6 Installation of Axial Fan

Axial fan is manufactured in vane-axial and tube-axial configuration, and is generally mounted in-line, suspended from ceiling. Special care is required for its mounting to minimize noise and vibration transmission to the structure and also to the connecting duct work. The fan is generally mounted on two

numbers of mild steel channels of size 100 mm × 50 mm × 5 mm, welded onto mild steel plate of 6 mm thickness, finished with 2 coats of red oxide and one coat of epoxy based enamel paint. Support rods for hanging the plate shall be cut and trimmed after finalizing the levels; extra length of 25 mm of support rods should be left for final adjustments. Burrs and sharp edges should be removed before applying finishing coat of paint.

All necessary accessories, as below, shall be provided for proper installation:

- a) Vibration isolators for the axial fans;
- b) Double canvas connection (of fire retardant material) at the outlets of each fan;
- c) Acoustic silencers at inlet and outlet of the fan as per manufacturer’s instructions; and
- d) Bird screen for the protection from extraneous elements, specially at fresh air intake and at exhaust outlet to outdoor.

Axial fan shall be installed in a manner so as to allow easy maintenance of the fan, its accessories, and easy service and possible replacement of fan motor. Field balancing shall be done.

Upon completion of installation, capacity of axial fan shall be measured by an anemometer. Power consumption shall be computed from measurements of incoming voltage and input current. Measured values shall conform to the data given by the vendor in technical submittal.

12.1.7 Installation of Ducting Works

The material and constructional requirements for ducts shall conform to the accepted standard [8-3(4)]. The installation of sheet metal duct work for air distribution and also its associated items, such as, air outlets and inlets, fresh air intake and smoke/fire dampers are covered in 12.1.7.1 to 12.1.7.3.

12.1.7.1 Duct support and hangers

Supporting details for low pressure rectangular ducting system are given below:

<i>Larger Side of Duct</i>	<i>Supporting Angle</i>	<i>Vertical Rod Diameter</i>	<i>Maximum Spacing between Supports</i>
mm	mm	mm	mm
Up to 900	40 × 40 × 5	8	2 400
901 to 1 500	40 × 40 × 5	8	2 400
1 501 to 2 400	40 × 40 × 5	10	2 400
2 401 and above	65 × 65 × 5	12	2 400

Supporting details for high pressure rectangular ducting system are given below:

<i>Larger Side of Duct</i>	<i>Supporting Angle</i>	<i>Vertical Rod Diameter</i>	<i>Maximum Spacing between Supports</i>
mm	mm	mm	mm
Up to 1 250	50 × 50 × 5	12	2 400
1 251 to 2 100	65 × 65 × 5	12	2 400
2 101 and above	75 × 75 × 5	15	2 400

Installation of other types of ducts and supports may be decided in consultation with the specialist structural designers. However, all safety and performance criteria in accordance with this Section shall be complied with in all cases.

12.1.7.2 Damper

Volume control damper shall be provided at the junction of each branch duct with main duct. Dampers shall be 2 gauge heavier than the gauge of large duct but should not be less than 20 gauge, and shall be rigid in construction so as not to flutter with the passage of air.

12.1.7.3 Access door

Access door shall be provided in duct before and after any equipment like in-line fan installed in duct. Access door shall also be provided before every smoke/fire damper locations. Access door shall be fabricated of the same material as the duct work and shall have minimum two hinges. Hinges shall be zinc plated and pins shall be of brass. Access doors shall be of minimum 305 mm × 305 mm size. At least two heavy solid fasteners and a brass handle shall be provided for each door. A continuous neoprene rubber gasket shall be fixed with adhesive to the opening frame.

12.1.8 Installation of Piping Works

Design, choice of materials, and the installation of chilled water/condenser water/drain water pipes, pipe fittings and valves shall conformed to relevant Indian Standards and shall meet the requirements of pressure rating for the system.

Chilled/condenser/hot water pipes of sizes up to 150 mm shall be heavy class, ERW mild steel black pipes conforming to the accepted standard [8-3(14)] and those of sizes above 150 mm shall be ERW/SAW pipes of Grade 330 conforming to the accepted standard [8-3(15)].

Piping shall be properly supported on, or suspended from, stands, clamps, springs, hangers, as required at site. Design of all the brackets, saddles, anchors, clamps and hangers shall be as per requirement identified by the system designer.

All pipes within HVAC plant room shall be supported off the floor of the plant room, and rest from the ceiling, with engineered support structures made of pipes and channels, with pipe always resting on the necessary high density PUF/wooden haunches. Minimum requirements in respect of support details, for horizontal and vertical chilled water pipes with mild steel channel and angle sections, are given in Table 13.

The recommended spacing between supports for various pipe sizes are given below:

Pipe Size mm	Spacing Between Supports m
Up to 12	1.5
15 to 25	2.0
30 to 250	2.0
Above 250	2.5

All pipe supports shall be of steel, coated with two coats of anti-corrosive paint and finally finished with epoxy paint. Where pipe and clamps are of dissimilar materials, a gasket shall be provided in between.

Vertical pipes passing through floors shall be parallel to wall and should be straight to wall duly checked with plumb line.

Wherever pipes pass through the brick or masonry/slab openings, the gaps shall be properly sealed as per the provisions given in Part 4 'Fire and Life Safety' of the Code.

Wherever insulated pipes are installed, pipes should be supported in such a way that no undue pressure is exerted on the insulation material.

Piping layout shall take due care of expansion and contraction in pipes, and shall include expansion joints, where required.

All pipes shall be accurately cut to the required size in accordance with relevant Indian Standards, edges beveled and burrs removed before laying. Open ends

of the piping section shall be closed as the pipe is installed to avoid entrance of foreign matter. Where reducers are to be made in horizontal runs, eccentric reducers shall be used for the piping to drain freely. In other locations, concentric reducers may be used.

Auto purge valves shall be provided at all highest points in the piping system for venting air. Air valves shall be 15 mm pipe size with screwed joints. Discharge from the air valves shall be piped through an equal sized mild steel or galvanized steel pipe to the nearest drain or sump. These pipes shall be pitched towards drain points.

Drain pipes shall be provided at all the lowest points in the system, as well as at equipment where leakage of water is likely to occur, also to remove condensate and water from pump glands. The drain pipe work can be carried out with threaded joints or simply welded.

12.1.9 Installation of Insulation Works

Fixing of thermal/acoustic insulation of ducts, pipes with valves and equipment room shall be done in accordance with 12.1.9.1 to 12.1.9.4.

12.1.9.1 Material

Selection of material shall be as per design requirement, such as, fibre glass, closed cell flexible elastomeric foams, expanded/extruded polystyrene (EPS/XPS) and polyurethane foam (PUF). The guidelines for insulating with fibre glass are given below; for other insulation materials, manufacturers' recommendations for installation should be followed.

12.1.9.2 Thermal insulation of duct

Surface of duct, on which the external thermal insulation is to be provided, shall be thoroughly cleaned with wire brush and rendered free from all dust and grease. Then, two coat of cold-setting adhesive compound (environment friendly), should be applied over the duct surface.

Table 13 Support Details for Chilled Water Pipe

(Clause 12.1.8)

All dimensions in millimetres.

Sl No. (1)	Pipe Size (2)	Ceiling Support (3)	Base Support (4)	MS Plate Size (5)	Fastener Size (6)
i)	Horizontal chilled water pipe support (for one pipe):				
a)	Up to 50	40 × 40 × 5 thick angle	40 × 40 × 5 thick angle	Cleat ISA 75 × 75 × 5	M10 × 2 numbers
b)	65 to 125	50 × 50 × 6 thick angle	75 × 40 MS channel	250 × 250 × 8 thick	M10 × 4 numbers
c)	150 to 250	75 × 40 MS channel	100 × 50 MS channel	250 × 250 × 8 thick	M10 × 4 numbers
d)	300 to 350	100 × 50 MS channel	150 × 75 MS channel	300 × 300 × 10 thick	M12 × 4 numbers
e)	400 to 500	100 × 100 × 6 MS channel box	150 × 150 × 6 MS channel box	400 × 400 × 10 thick	M16 × 4 numbers
f)	600 to 700	150 × 150 × 6 MS channel box	150 × 150 × 6 MS channel box	400 × 400 × 12 thick	M16 × 4 numbers
ii)	Vertical chilled water pipe support (for one pipe):				
a)	65 to 125	—	75 × 40 MS channel	250 × 250 × 8 thick	M10 × 4 numbers
b)	150 to 250	—	100 × 50 MS channel	250 × 250 × 8 thick	M10 × 4 numbers

The thermal insulation material should then be wrapped around the duct with aluminium facing on outer side. Joints of insulation should be properly sealed with either same type of material or aluminium tape of 50 mm width on all longitudinal/transverse joints. Finally PVC straps should be fixed at suitable interval to ensure that the insulation is properly fixed with the ducts.

The insulation should then be covered with 0.63 mm × 19 mm galvanized iron (GI) wire mesh netting on the outside of the duct, where it is exposed to the weather and should be additionally covered with either a layer of tar-felt, or two coats of 10 mm thick sand cement plaster.

12.1.9.3 Acoustic lining of duct

Acoustic lining of duct should be carried out as follows:

- a) The inside surface of duct on which the acoustic lining is to be provided should be thoroughly cleaned with wire brush and rendered free from all dust and grease.
- b) The material to be used for duct lining should be 12/25 mm thick resin bonded fibre glass rigid board having a density of 48 kg/m³. The board should be fixed inside the duct using suitable adhesive and covered with fibre glass tissue paper.
- c) The insulation board should then be covered with 0.5 mm thick perforated aluminium sheet with at least 20 to 40 percent perforation.
- d) The insulation board and aluminium sheet should be secured with cadmium coated bolts, nuts and cup washers/steel screws.
- e) Finally the ends should be sealed completely, so that no lining material is exposed.

The lining of initial length of the duct may have to be done as per the requirement at site.

Alternatively, open cell flexible elastomeric foams or fire retarding foam board panels, specially formulated to attenuate noise may also be used. These should be fixed inside the duct with special eco-friendly cold-setting adhesive compound.

12.1.9.4 Acoustic lining in equipment room

Acoustic treatment in equipment room to prevent noise transmission to adjacent occupied areas should be provided on the walls and ceiling of equipment room with acoustic lining of thermal insulation material. The process should be as below:

- a) Wall/roof surface should be thoroughly cleaned with wire brush.
- b) A 610 mm × 610 mm frame work of 25 mm × 50 mm × 25 mm or 50 mm × 50 mm × 50 mm 'U' shape channel, for 25 mm or 50 mm thick acoustic lining respectively, made of 0.6 mm

thick galvanized steel sheet should be fixed on to walls leaving 610 mm gap above floor (to prevent damage from flooding) by means of wall plug/screw anchors in walls. Similar frame work should also be fixed on ceiling by means of dash fasteners.

- c) Resin bonded glass wool/mineral wool as specified, cut to size should be fitted in the frame work and covered with fibre glass tissue paper.
- d) Surfaces should be finished by covering with 0.5 mm thick perforated aluminium sheet having perforation 20 to 40 percent with brass screws.
- e) All horizontal and vertical joints should be covered with at least 25 mm wide, 1 mm aluminium strips held in position by steel or brass screws.

12.1.9.5 Insulation of CHW/HW refrigerant pipes

Pipe insulation material should be EPS/XPS/PUF/closed cell flexible elastomeric foam/fibre glass as per requirement, specified with suitable density and thickness. Adhesive used for setting the insulation should be non-flammable, vapour proof, cold-setting, eco-friendly compound. Generally, pipe insulation material is available in pre-moulded pipe insulation sections, which should be applied to the pipe surface and sealed as described below:

- a) The pipe to be insulated should be cleaned thoroughly with steel brush for removing dirt, rust and grease.
- b) A coat of zinc chromate primer and two coats of cold setting adhesive compound should be applied on pipes.
- c) Insulation of specified thickness should be fixed tightly and all joints should be sealed with adhesive compound.

The insulation should then be finished as per the specific requirement of the site, as given below:

- 1) *Inside the building* — Insulation over the pipe work exposed in the building should be finished with specified thickness of aluminium sheet cladding, over a vapour barrier, with 50 mm overlap and tied down with lacing wire.
- 2) *Outside the building* — Insulation over the pipe work exposed to weather should be finished with vapour barrier, and 12 mm thick cement-sand plaster in two layers of 6mm thick each, followed by curing of minimum 48 h.
- 3) *Buried pipe insulation* — For pipes outside the building and laid underground, the insulation should be covered with suitable

gauge polythene faced hessian, (the polythene facing outward), with 50 mm overlap. All joints should be sealed with bitumen. A layer of 0.50 mm × 20 mm GI wire mesh netting should be provided over it butting all joint, and it should be laced down with GI wire. A 20 mm thick cement-sand plaster (1 : 4) should be provided in 2 layers of 10 mm thickness each and should be water proofed by applying hot bitumen and fixing tar-felt over the plaster. It should be finally finished with a coat of hot bitumen.

- 4) *Pump insulation* — Chilled water pump should be insulated to the same thickness as the pipe to which they are connected and application should be same as above. Care should be taken to apply insulation in a manner as to allow the dismantling of pumps without damaging the insulation.
- 5) *Insulation of valves and fittings in chilled water line* — All valves, fittings, strainers, etc, should be insulated to the same thickness and in the same manner as for the respective piping, taking care to allow operation of valves without damaging the insulation.

12.2 Installation of Split Air Conditioners

Split air conditioners shall be installed as per the procedure given below:

- a) The outside unit shall be installed on a place solid enough to bear the weight and vibration of the unit, where the operation sounds will not be amplified. The location shall be such that the hot air discharged from the unit or the operation sounds may not disturb the surroundings.
- b) All piping, fittings, and insulation shall then be installed as per manufacturer's requirements. The units shall be installed in level and plumb. Evaporator-fan components shall be installed using manufacturer's standard mounting devices securely fastened to building structure. Refrigerant tubing and fittings shall then be installed and connected.
- c) The clearance for maintenance shall be maintained while selecting the location. Sufficient space for air passage around the unit for air inlet and the air outlet shall be provided. The site shall be free from the possibility of flammable gas leakage in a nearby place. The inside and outside unit's power cords and inter-unit wire shall preferably be kept at least 3 m away from television and radio sets to avoid interference to images and sounds.
- d) After piping has been completed, the refrigerant piping system shall be pressure tested at a pressure of 21 kg/cm² on the high side and 10 kg/cm² on the low side. The pressure shall be maintained on the system for a minimum of 12 h. The system shall be evacuated when the surrounding ambient air is not less than 16°C. A minimum vacuum of 500 microns of Hg shall be pulled on the system and maintained for 12 h. The system shall be charged as recommended by the equipment manufacturer.
- e) *Start-up* — Manufacturer or factory-authorized service representative shall be engaged to perform start-up service. Manufacturer shall provide on-site start-up and commissioning assistance through job completion. Installation and start-up checks shall be completed according to manufacturer's written instructions.

12.3 Installation of VRF Systems

VRF systems shall be installed as per the procedure given below:

- a) All piping, fittings, and insulation shall be installed to meet manufacturer's requirements. Units shall be installed in level and plumb. Evaporator-fan components shall be installed using manufacturer's standard mounting devices securely fastened to building structure. Refrigerant tubing and fittings shall then be install and connected.
- b) Installer shall supply isolation ball valves for zoned refrigerant isolation. Installer shall supply isolation ball valves with Schrader connection for isolating refrigerant charge and evacuation at each connected inside unit and condensing unit. Isolation ball valves, with Schrader connection, are required for instances of inside unit isolation for troubleshooting, repair, or replacement without affecting the remainder of the system. These are also required at condensing unit connection to isolate unit for troubleshooting, repair or replacement and as required to provide partial capacity heating/cooling in the instance of a failure of one of the multiple outdoor unit (condensing unit) compressors.
- c) During brazing an inert gas (such as nitrogen) shall be continuously passed through the system at a rate sufficient to maintain an oxygen free environment to prevent the formation of copper oxide scale. After piping has been completed, the refrigerant piping system shall be pressure tested at a pressure of 21 kg/cm² on the high

side and 10 kg/cm² on the low side. The pressure shall be maintained on the system for a minimum of 12 h. The system shall be evacuated when the surrounding ambient air is not less than 16°C. A minimum vacuum of 500 microns of Hg shall be pulled on the system and maintained for 12 h. The vacuum pump displacement shall be not less than 4 CMH for up to 15 t. The system shall be charged as recommended by the equipment manufacturer.

- d) Electrical wiring, both high and low voltage, shall comply with the requirements laid down in Part 8 'Building Services, Section 2 Electrical and Allied Installations' of the Code.
- e) *Start-up* — Manufacturer or factory-authorized service representative shall be engaged to perform start-up service. Manufacturer shall provide on-site start-up and commissioning assistance through job completion. Installation and start-up checks shall be completed according to manufacturer's written instructions. This shall include a factory start-up for factory provided control devices as well as configuring control points for other devices. Service representative shall completely configure all control devices.
- f) *Demonstration* — Manufacturer or factory-authorized service representative shall also be engaged to train owner's maintenance personnel to adjust, operate and maintain individual units and complete system. This shall include training of the owner's energy management department representatives.
- g) The indoor units and outside condensing units shall be installed in accordance with the manufacturer's recommendations and as shown on the shop drawings.

12.4 Installation of Mechanical Ventilation System

12.4.1 Installation of Equipment

12.4.1.1 In selecting the location of equipment room, aspects of efficiency, economy and good practice should be considered and wherever possible, it shall be made contiguous with the building. This room shall be located as centrally as possible with respect to the area served and shall be free from obstructing columns. Equipment room should preferably be located adjacent to external wall to facilitate equipment movement and ventilation. It should also be close to main electrical panel of the building, if possible, in order to avoid large cable lengths.

12.4.1.2 Location and dimensions of shafts and openings in walls, slabs and roof for ducting, cables, pipes, air intakes and exhaust (if envisaged) should be

planned at the concept stage itself. Shafts should be located adjacent to the equipment or within the room itself.

Evaporative cooling units (air washers) should be located preferably on summer-windward side. They should be painted white or with reflective coating or thermally insulated, so as to minimise solar heat absorption.

In locating the units, care should be taken to ensure that their noise level is not objectionable to the neighbours.

Exhaust air devices, preferably on leeward and overhead side may be provided for effective movement of air.

The equipment room should be adequately dimensioned keeping in view the need to provide required movement space for personnel, space for entry and exit of ducts, the need to accommodate air intakes and discharge, operation, maintenance and service requirements. In case the equipment is located in basement, equipment movement route shall be planned to facilitate future replacement and maintenance. Service ramps or hatch in ground floor slab should be provided in such cases. Also, arrangements for floor draining should be provided.

In the case of large installations, it is advisable to have a separate isolated utility services block.

12.4.1.3 The floor of the equipment room should be light coloured and finished smooth with epoxy coating. For floor loading, the air conditioning engineer should be consulted (*see also* Part 6 'Structural Design, Section 1 Loads, Forces and Effects' of the Code).

Arrangements for draining the floors shall be provided. The trap in floor drain shall provide a water seal between the equipment room and the drain line. Water proofing shall be provided for floor slab of evaporative cooling unit room, AHU room and AWU room.

12.4.1.4 Supporting of water pipe within equipment room spaces should be normally from the floor. However, outside equipment room area, structural provisions shall be made for supporting the water pipes from the floor/ceiling slab. All floor and ceiling supports, make-up and drain connection pipes, ducting cables/cable trays, etc, shall be isolated from the structure to prevent transmission of vibrations.

12.4.1.5 Plant machinery in the plant room shall be placed on plain/reinforced cement concrete foundation and provided with anti-vibratory supports. All foundations should be protected from damage by providing epoxy coated angle nosing. Seismic restraints requirement may also be considered.

12.4.1.6 Wherever necessary, acoustic treatment should be provided in plant room space to prevent noise transmission to adjacent occupied areas.

12.4.1.7 In case of large and multistoried buildings, independent ventilation/air washer units should be provided for each floor. The area to be served by the ventilation system should be decided depending upon the provision of fire protection measures adopted. All such units should preferably be located vertically one above the other to simplify location of pipe shafts, cable shafts and drain risers.

12.4.1.8 Openings of adequate size should be provided for intake of fresh air. Fresh air intake shall have louvers having rain protection profile, with volume control damper and bird screen. Outdoor air intakes and exhaust outlets shall be effectively shielded from weather and insects. Minimum distance of air intakes from exhaust outlets or from sources whose contamination concentration levels are greater than normal in the locality in which the building is located, shall be so as to avoid short circuiting of air.

12.4.1.9 Access doors to equipment rooms should be through single/double leaf type, air tight, opening outwards and should have a sill to prevent flooding of adjacent occupied areas.

12.4.1.10 It should be possible to isolate the equipment room in case of fire. The door shall be fire resistant. Smoke damper shall be provided in each supply/return air duct at fan room, air handling unit room and air washer unit room wall crossings. The annular space between the duct and the wall should be fire sealed using appropriate fire resistance rated material. Fire-rated access panel shall be provided in the supply and return air ducts, within equipment room, to inspect the smoke damper at wall crossings.

12.4.2 Energy Efficient Installation of Ventilation Fans

The performance of a fan when installed in a system can be adversely affected by the flow conditions at fan inlet and outlet. Manufacturers' fan performance ratings are mostly based on optimum arrangements of fan inlet and outlet connections to provide uniform straight flow condition. Any deviation from this will result in additional pressure losses known as fan system effects and therefore cause deficient fan performance. Provisions in **7.2.8.4** and **7.2.8.5** should be followed to minimise fan system effects and ensure efficient fan performance.

12.4.3 Safe Installation Practices for Fans

Same installation practices for fans as given below shall be followed:

- a) *Centrifugal fans:*
 - 1) The concrete foundation for the fans,

wherever required, shall be prepared and shall have the foundation bolts and base plates. Foundation bolts and base plates should be placed securely in proper position while the foundation is cast. Else the fan shall be mounted on suitable channel frame.

- 2) Vibration isolation base for both fan and motor should be built as an integral part and be mounted on concrete foundation through anti-vibration isolator having an efficiency of 90 percent.
 - 3) Fan outlet connections should be by means of flexible fire retardant canvas connections.
 - 4) At the free suction side, safety screen shall be provided.
 - 5) For belt driven fans, removable belt guard should be provided.
 - 6) For direct driven fans, removable coupling guard should be provided.
- b) *Axial flow fans:*
- 1) Removable safety screens should be provided on either side of fan.
 - 2) The fans shall be properly grouted on the walls with vibration isolator pads. Vibration isolators shall also be used for suspended fans (from ceiling or primary support).
 - 3) For ducted application, the fans shall be connected to the duct by means of flexible fire retardant canvas connections.
- c) For fans placed in cabinets, the following shall be provided/carried out:
- 1) *Door interlock with limit switch* — to switch off the fan and switch on the bulkhead lamp when fan section door is opened.
 - 2) Safety screens at free fan inlets and outlets.
 - 3) Adequate lighting in the fan section.
 - 4) Water drain in fans section.
 - 5) Transparent inspection windows of minimum 150 mm diameter.
 - 6) Lockable doors.
 - 7) Adequate space around fan/motor for ease of service/maintenance.

In case of large size cabinet fans where plug fans (exposed impeller) are provided, double doors at the fan section shall be provided along with limit switch as an added safety precaution.

12.5 Fire Control

The requirements for smoke control systems are with the objective to accomplish one or more of the following:

- Inhibit smoke from entering stairwells, means of egress, smoke refuge areas, elevator shafts, or similar areas.
- Maintain a tenable environment in smoke refuge areas and means of egress during the time required for evacuation.
- Inhibit the migration of smoke from the smoke zone.
- Provide conditions outside the smoke zone that enable emergency response personnel to conduct search and rescue operations and to locate and control the fire.
- Contribute to the protection of life and to the reduction of property loss.

The smoke control system shall meet the requirements of Part 4 'Fire and Life Safety' of the Code.

12.6 Vibration Isolation

The objective of vibration isolation is primarily to minimise the effect, of the dynamic forces generated by moving parts in a machine, being transmitted into the surrounding structure.

This is accomplished by incorporating a resilient material, which when subjected to a static load, deflects and by so doing establishes the natural frequency of the isolation system. The disturbing frequency, f_d , of a machine may be readily determined either by measurement or by the known operating characteristics of the equipment. Generally the lowest revolutions per minute (r.p.m.) in the system is used as the disturbing frequency.

The natural frequency, f_n , of a machine set on resilient material is a function of the static deflection of the resilient material under the imposed load. For practical purposes the natural frequency f_n is described by the formula:

$$f_n = \frac{946.5}{\sqrt{d}}$$

where

d = static deflection, in mm.

The ratio (f_d/f_n) establishes the efficiency of the isolation from the following formula:

$$E = 100.1 - \frac{1}{\left(\frac{f_d}{f_n}\right)^2 - 1}$$

where

E = percentage of vibration isolated;

f_d = disturbing frequency of the isolated machine; and

f_n = natural frequency of the isolated machine.

The percentage of isolation efficiency attained is a measure of the amount of reduction in the amplitude of the transmitted mechanical vibration. Reference may be made to Fig. 4 to readily select the static deflection required to attain desired isolation efficiency.

The percent of isolation efficiency may be determined from Fig. 4, by reading from the graph at the intersection of vibration (disturbing) frequency and static deflection.

12.6.1 Vibration Transmission and Noise

Noise and vibration are intrinsic components of several activities in which machinery with moving parts are used. The positioning of anti-vibration devices between the machinery and their support structure acts as isolation, without any intervention on the balancing of the machine itself.

12.6.2 Vibration Isolation of Mechanical Equipment

Three principle factors control the selection of an isolator for a particular machine. The first is the weight to be supported, the second is the disturbing frequency of the machine and the third is the rigidity of the structure supporting the machine.

The normal method to isolate the vibration from building services plant is to support the equipment on resilient supports or isolators, for example, helical steel springs; rubber blocks or pads. These resilient supports or isolators, otherwise known in the building services industry as anti-vibration mounts (AVMs), shall be selected and positioned carefully. Incorrect specification and use can equally worsen the vibration problem. Most anti-vibration devices are generally elastomer based, elastomer/metal bonded, springs or fluid based.

12.6.3 Selection of Suitable Anti-Vibration Mounts

The following steps may be used for calculation of load and for the selection and positioning of the anti-vibration mount for equipment and for building services pipe work.

- Estimating the force or load on each mounting point* — The weight distribution at each mounting point is dependent on the position of that point relative to the centre of gravity of the total mass. The equipment manufacturer shall provide the equipment weight and the centre of gravity. The load on each mounting point may be calculated by taking moments about each mounting point. These calculations may be performed manually, if there are 4 mounting points, each at the corner of a rectangular base. However, if there are more than 4 points, or the base is not rectangular, then the calculations are more complex and computer programs should be used.

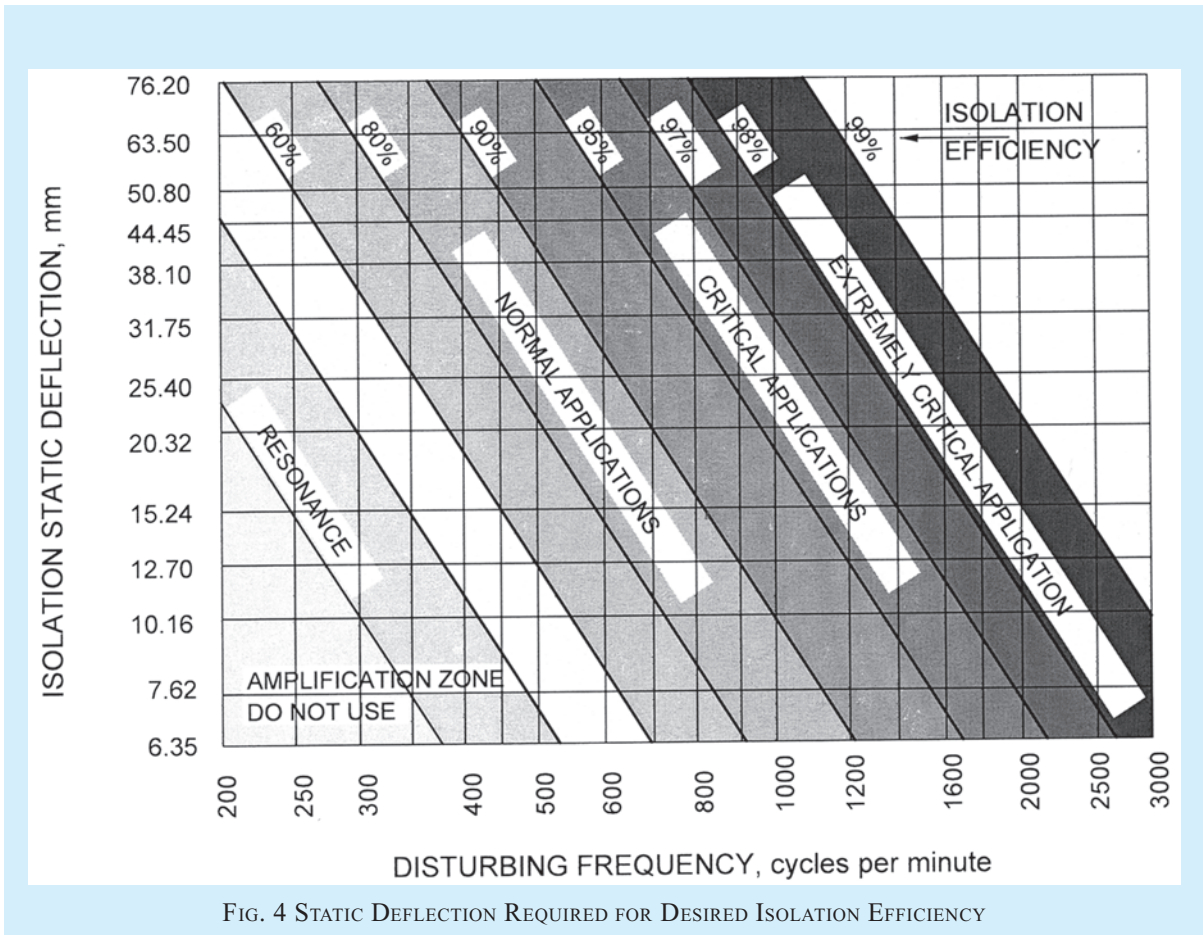

FIG. 4 STATIC DEFLECTION REQUIRED FOR DESIRED ISOLATION EFFICIENCY

- b) *Selecting the type of anti-vibration mount* — Once the load on each mounting point has been calculated, or if the information was given directly by the manufacturer, designer shall evaluate to decide which type of mount is best suited for the type of equipment being supported, operating speed (speed of rotation), the supporting building structure, environmental conditions (for example, wind loadings) and space availability, and then select the appropriate mount.
- The mathematical model used for the selection of the anti-vibration mounts is a simple spring/mass arrangement, based on the principle of supporting mass being very large compared with the equipment mass. In practice, if the equipment is placed on suspended supports of increasing span, then these act as further ‘springs’ in the model, which require a higher performance from the anti-vibration mount. This usually means higher deflection in the case of a spring mount, although the amount of damping offered by the anti-vibration mount may also need to be increased when faced with light weight structures and ‘live’ steel frameworks.
- c) *Selecting the size or load rating of the anti-vibration mount* — Having established the equipment load and type of mount, the next

step is to determine the load rating of the mount. The selection will depend upon the load, the speed of rotation (usually the lowest) and the isolation efficiency required. Charts are available for prediction of the isolation efficiency based upon the speed of rotation and the percentage loading of the spring. When selecting rubber mounts, these charts will only give an approximate indication of the isolation efficiency, because rubber has high inherent damping properties that reduce the maximum efficiency attainable.

For each of the load points in turn, one has to look on the selected anti-vibration mount data sheet, and find the next highest load rating. Dividing the actual load by the mount load rating, gives the percentage loading.

12.6.4 Seismic Isolation of Non-Structural Components

In addition to the structural framing and the floor and roof systems, buildings include many components and systems which are not structural in nature, but these can be damaged by earthquake effects. These include,

- a) mechanical components and systems including air conditioning equipment;
- b) electrical components including transformers, switchgear, motor control centres, lighting, and raceways;

- c) fire protection systems including piping and tanks; and
- d) plumbing systems and components including piping, fixtures, and equipment.

The design and installation requirements should ensure that,

- 1) most of these components are adequately attached to the supporting structure so that earthquake shaking does not cause them to topple or fall, injuring building occupants or obstructing exit paths.
- 2) those pieces of equipment and components which are required to provide for the safety of building occupants (for example, emergency lighting and fire suppression systems), continue to function after an earthquake.
- 3) non-structural components critical to the operability of essential facilities, such as, hospitals, airports continue to operate following strong earthquake shaking. These facilities (buildings) include,
 - i) hospitals,
 - ii) airports,
 - iii) emergency response centres,
 - iv) data centres, and
 - v) buildings vital to national defence.

Their design shall conform to the available standards and specialist literature. The performance objectives and compliance method and expectations are given in Table 14 and Table 15.

Table 14 Non-Structural Seismic Performance Objectives
(Clause 12.6.4)

SI No.	Performance Objective	Design Objective Description
(1)	(2)	(3)
i)	Position retention	Maintain positive retention of non-structural position, under design level earthquake demands, without consideration of frictional resistance produced by the effects of gravity. This includes position retention of non-structural anchorage, attachments and the force resisting skeleton.
ii)	Systems interaction avoidance	Account for unwanted interaction, under design-level earthquake demands, between non-structural systems and anything else (building elements or other installed non-structural systems) that might be located in the immediate vicinity of the non-structural installation, so that failure of one system or contact between systems does not cause consequential damage of an essential system.
iii)	Active operation	Maintain active operation functionality of mechanical and electrical equipment and distribution systems following (that is, not during) application of design level earthquake demands.

Table 15 Non-Structural Seismic Compliance Methods and Expectations
(Clause 12.6.4)

SI No.	Performance Objective	Validation Method	Compliance Expectation
(1)	(2)	(3)	(4)
i)	Position retention	a) Analysis	Seismic calculation and analysis may be used to validate that non-structural anchorage, force resisting skeleton and attachments have position retention capacity equal to or greater than the project-specific design-level demand for the application installation location. Both strength design and allowable stress design approaches are accepted.
		b) Experience data	The use of earthquake experience data, based upon nationally recognized procedures, may be used to establish non-structural position retention capacity provided that the substantiated seismic capacities equal or exceed the project specific design-level demand for the application installation location.
		c) Testing	The use of seismic simulation testing, based upon an internationally recognized testing standard procedure, may be used to establish non-structural position retention capacity provided that the seismic capacities equal or exceed the project-specific design-level demand for the application installation location.
ii)	Systems interaction avoidance	a) Inspection	Visual inspection of the non-structural installation is performed to validate that no unwanted system interactions may result under the project-specific design-level earthquake demands.
iii)	Active operation	a) Experience data	The use of earthquake experience data, based upon nationally recognized procedures, may be used to establish non-structural active operation capacity provided that the substantiated seismic capacities equal or exceed the project specific design-level demand for the application installation location.
		b) Testing	The use of seismic simulation testing, based upon an internationally recognized testing standard procedure, may be used to establish non-structural active operation capacity provided that the seismic capacities equal or exceed the project-specific design-level demand for the application installation location
		c) Combined testing and analysis	The use of combined seismic calculations and seismic simulation testing may be used to establish non-structural active operation capacity for physically massive systems (that is, large-class) that are impractical to test as complete systems. The testing aspects need to conform to nationally recognized testing standard procedures. The established active operation capacity, using combined testing and analysis, is to equal or exceed the project-specific design-level demand for the application installation location

13 SYMBOLS, UNITS, COLOUR CODE AND IDENTIFICATION OF SERVICES

13.1 Units and symbols to be used in air conditioning, heating, mechanical ventilation and refrigeration system shall be in accordance with good practice [8-3(16)].

13.2 Colour code is required for easy identification of various items in an air conditioning installation for correct interpretation and identification. This shall promote greater safety and shall lessen chances of error, confusion or inaction in times of emergency. Colour shade shall be generally in accordance with accepted standard [8-3(17)].

13.3 Colour band shall be 150 mm wide, superimposed on ground colour to distinguish type and condition of fluid. The spacing of band shall not exceed 4.0 m.

13.4 Further identification may also be carried out using lettering and marking direction of flow.

13.5 Services Identification

13.5.1 Pipe Work Services

13.5.1.1 The scheme of colour code for painting of pipe work services for air conditioning installation shall be as indicated in Table 16.

13.5.1.2 In addition to the colour bands specified above, all pipe work shall be legibly marked with black or white letters to indicate the type of service and the direction of flow, as identified below:

Hot water	:	HW
Chilled water	:	CHW
Condenser water	:	CDW
Steam	:	ST
Condensate drain	:	CN

Table 16 Scheme of Colour Code of Pipe Work Services for Air Conditioning Installation
(Clause 13.5.1.1)

Sl No.	Description	Ground Colour	Lettering Colouring	First Colour Band
(1)	(2)	(3)	(4)	(5)
i)	Cooling water	Sea green	Black	French blue
ii)	Chilled water	Sky blue	Black	Black
iii)	Central heating	Dark blue	Black	Canary yellow
iv)	Condensate drain pipe	Black	White	
v)	Vents	White	Black	
vi)	Valves and pipe line fittings	White with black handles	Black	
vii)	Belt guard	Black yellow diagonal strips		
viii)	Machine bases, inertia bases and plinth	Charcoal grey		

13.5.2 Duct Work Services

13.5.2.1 For duct work services and its insulation, colour triangle may be provided. The size of the triangle will depend on the size of the duct and viewing distance, but the minimum size should not be less than 150 mm in length.

The colour for various duct work services shall be as given below:

Services	Colour
Conditioned air	Blue
Ward air	Yellow
Fresh air	Green
Exhaust/extract/recirculated air	Grey
Foul air	Brown
Dual duct system hot supply air	Red
Cold supply air	Blue

13.5.3 Valve Labels and Charts

Each valve shall be provided with a label indicating the service being controlled by it, together with a reference number corresponding with that shown on the valve charts and on the ‘as-built’ drawings. The labels shall be made from 3-ply (black/white/black) traffolyte material showing white letters and figures on a black background. Labels shall be tied to each valve with chromium plated linked chain.

14 BUILDING AUTOMATION SYSTEM FOR HVAC CONTROL, MONITORING AND VERIFICATION

14.1 General

The energy use of buildings is affected by several factors that change with time. Be it usage patterns, properties of the structure, installed equipment or weather outside — all of them affect the energy consumption of the building significantly. The evaluation of energy savings due to improvements in a building thus becomes a difficult task. Technology is now available that can quantify the factors affecting consumption in more detail than just logging data at the meter.

14.1.1 Role of Building Automation System (BAS) in HVAC Operation and Maintenance

The core functionality of BAS is to keep the building indoor environmental conditions, namely, temperature, humidity, lighting and indoor air quality, within the specified range, monitor system performance, and provide device failures and/or malfunction alarms. It typically consists of:

- a) *HVAC controls*, consisting of sensors, thermostats, controllers, actuators, communication devices, control panels, and user interface associated with building climate control system;

- b) *Lighting controls*, specifically focused on integrated and networked lighting controls;
- c) *Fire and life safety controls*, including sensors, controllers, master panels, actuators, and communication devices for fire detection and control, but excluding actual fire suppression components; and
- d) *Security and access controls*, including sensors, access controllers, panels, card-readers, cameras, user interface and IT hardware.

Some of the BAS functions for HVAC include, monitoring status of sensors and controlled devices, scheduling equipment on and off, scheduling set points and setbacks, and trending for equipment operation schedules. BAS is also used to optimize the operation of the various building systems, especially the HVAC system to reduce its energy consumption.

Some of the BAS functions for lighting include scheduling lights to turn on and off, maintain fixed illuminance levels, and integrating daylighting with electrical lighting.

Installing BAS helps in conserving the energy consumed by HVAC system, lighting, etc. However, it is important to note that BAS should be installed only in case of large complex HVAC systems for their optimum usage. It is not required for smaller equipment like split ACs, unitary systems and package units.

14.2 BAS Design Requirements

The BAS design shall take into account the following:

- a) *General considerations*:
 - 1) Building construction, for example, metal frame, concrete, size and thermally active building components;
 - 2) Type of building, for example, high rise, single storey, open campus, tunnel;
 - 3) Building usage type and profile, for example, hospital, single/multi-tenant offices, institutional, industrial, and commercial and residential complexes;
 - 4) Space usage profile, for example, occupation schedules, diverse usage of space, continuous operation;
 - 5) System integrity including off-site considerations, for example, communication infrastructure and topology, availability, reliability, response time, safety and security, redundancy;
 - 6) Intended model of building operation and technical services, for example, third party, caretaker, trade segregation, user account levels;

- 7) Energy supply requirements, for example, alternative energy systems, load shedding, energy monitoring;
- 8) Safety and security systems integration with BAS and mutual interaction, for example, fire system and access control system with their interoperability area and integration depth;
- 9) Implementation of the project in phases, for example, timescales for each phase, constraints on plant shutdowns, impact on continuous operation;
- 10) Budget, for example, charge for O&M, overtime work;
- 11) Future usage, for example, spare capacity, flexibility, future intended extensions; and
- 12) Commissioning process.

- b) *Integration requirements*:

- 1) Deployment of special system integration co-ordination group;
- 2) Allocation of responsibilities, for example, for subsystem functionality and interface, for delivery of integration of subsystems, setting clear battery limits;
- 3) Vendor and manufacturer independence, for example, standardized protocols, industry standard open back bone like Ethernet/BACnet/Lonworks/Modbus, etc; profiles and interface;
- 4) Enhanced energy performance, for example, interdisciplinary operation of HVAC, blinds and lighting controls;
- 5) Compatibility, for example, software/hardware version of subsystems, protocol version, proprietary protocols;
- 6) Interoperability, for example, data sharing, event and alarm management, scheduling, trend and event logging, device and network management;
- 7) Functional interaction, for example, fans disabled by fire conditions;
- 8) Single seat operation, for example, shared computer, consolidated user information and alarms;
- 9) Infrastructure sharing, for example, ethernet structured cabling, IT backbone and UPS power systems;
- 10) Commissioning, for example, availability and interaction of subsystems;
- 11) Interoperability diagnostics, for example, event recording, device and object binding integrity, protocol analysing; and

- 12) Capability to configure a dashboard that will give a summary view of all the different systems integrated and their status to the user.
- c) *Physical requirements:*
- 1) New equipment and its ability to be monitored and controlled, for example, adding monitoring and control;
 - 2) Existing equipment and its ability to be monitored and controlled, for example, reuse, adding functionality;
 - 3) Existing controls or BAS, for example, integrate, migrate, replace;
 - 4) Space, for example, for cabinets, wall mountings, human system interface (HSI);
 - 5) Human system interface, for example, local display, operator workstation;
 - 6) Local conditions, for example, environmental, temperature, humidity, seismic risk, extreme weather;
 - 7) Cabling, for example, topology, media type, size, rating, environment;
 - 8) Power supply, for example, frequency, voltage, emergency power supply, UPS.
- d) *Operational requirements:*
- 1) Priorities for operation of the building, for example, emergency situations, normal conditions, overrides;
 - 2) Occupancy profile, for example, schedules/calendar, set points, operating modes, daylight saving, energy use;
 - 3) Energy performance, for example, energy usage, energy savings;
 - 4) Comfort conditions, for example, thermal, visual, acoustic, air quality;
 - 5) Human system interfaces, for example, local override/indication devices, operator and monitoring units or panels, operator work stations including visual display units, internet browser on different types of platforms.
- e) *System requirements:*
- 1) Priorities for operation, for example, safety of personnel, protection of equipment, occupancy profile, comfort, energy savings, cost savings, reliability, indoor air quality;
 - 2) Control strategies;
 - 3) Management functions;
 - 4) Data storage, data retrieval;
 - 5) Maintenance management requirements, for example, condition-based monitoring, local/remote reporting;
- 6) Energy management requirements;
 - 7) Alarm strategy, for example, categories, priorities, delivery, routing;
 - 8) Human system interface, for example, localization, multi-language, graphics quality, types, functionality;
 - 9) System support, for example, remote access, technical support;
 - 10) System performance, for example, accuracy, response time, display response;
 - 11) System reliability, for example, availability, redundancy;
 - 12) Documentation, for example, format and media, content, quantity, compliance certificates; and
 - 13) System level diagnostics, to help user diagnose equipment faults, sensor faults, etc. This will help reduce downtime in case of failure.
- f) *Site and client-specific requirements:*
- 1) Installation, for example, electrical, mechanical, controls;
 - 2) Commissioning and handover requirements, for example, witness testing, process for uncompleted actions, summer/winter operation, phased delivery, documentation of the results;
 - 3) Training, for example, instructions for use, operation and maintenance, system/product training;
 - 4) Documentation, for example, language, content, media, certificates, software licences and backup;
 - 5) Post completion, for example, warranty/guarantee requirements, spare parts requirement, maintenance;
 - 6) Requirements and software updates;
 - 7) Application of the commissioning process, for example, required qualification and role of commissioning authority; and
 - 8) Ability to upgrade to new feature, new technology that enables vendor or manufacturer independence.

14.3 BAS for Monitoring and Control

BAS is designed to monitor and control the HVAC and lighting, and only monitor the security, fire and flood safety in the building. It also provides the information and tools that building managers need both to

understand the energy usage of the building and to control and improve the buildings' energy performance.

In order to provide data necessary to improve building systems operation, monitoring and controls should be considered for boilers, chillers, pumps, cooling towers, heat pumps, air handling units, large fan-coil units, major exhaust fans, major water supply pumps, lighting panels, electric heaters, receptacle panels, substation, motor control centre, major feeders, service water heaters, process loads, and computer room. For overall success of the system, it is critical for the BAS to have the capability to allow building staff to measure and record electrical values, such as voltage, current, power, energy, power factor and other power quality parameters for proper performance monitoring. It also calculates, and records system status, water use, energy use at the main meter or of particular end-use systems, demand, and hours of operation, as well as start and stop of building systems, control lighting, and print alarms when systems do not operate within specified limits.

All the measured values are aggregated and trended in both instantaneous and time based numbers for chillers, boilers, air handling units and pumps. The data can be made accessible through a web browser. A graphical user interface must offer trending, scheduling, downloading memory to field devices, real-time graphic programs, parameter changes of properties, set point adjustments, alarm/event information, confirmation of operators, and execution of global commands. This concise representation makes interpretation of collected data robust and more user friendly. A floor manager is able to precisely monitor all aspects using an effective and dynamic system like the BAS.

BAS monitoring can be broadly divided into two aspects, namely, energy monitoring and indoor environment monitoring. Parameters to be measured for energy monitoring have already been listed above. Indoor environmental quality (IEQ) encompasses the conditions inside a building — air quality, lighting, thermal conditions, ergonomics and also their effects on occupants and residents. Strategies for addressing IEQ include those that protect human health, improve quality of life and productivity, and reduce stress and potential injuries. Hence it is necessary to monitor indoor environment quality in both real-time and long-term basis. Since manually managing it is tedious and cumbersome, the use of a BAS is tailor-made to address this specific need. HVAC system provides air to building occupants at a comfortable temperature and humidity, which is also free of harmful concentrations of air pollutants. Also, building ventilation is an important factor affecting the relationship between airborne transmission of respiratory infections and the health and productivity of workers. Improper operation

and maintenance of HVAC system is one of the most common problem that impact workplace IEQ. HVAC system includes all of the equipment used to ventilate, heat, and cool the building; to move the air around the building (ductwork); and to filter and clean the air. HVAC system can thus have a significant impact on how pollutants are distributed and removed. Maintaining good IEQ requires constant attention to the building's HVAC system, which includes the design, layout and pollutant source management or air filtration, and the same is facilitated by BAS.

14.4 BAS for Measurement and Verification

Manual analysis of the energy consumption pattern of a building can be a difficult exercise considering that numerous factors such as building envelope design and local climate constantly effect the lighting and HVAC system operation, resulting in a significant impact on building's energy consumption. To simplify this, a process called measurement and verification is used to analyse the energy savings obtained through design and operation of building efficiently. The process of determining the actual savings produced within a facility, upon implementation of an energy efficiency programme, is called measurement and verification (M&V).

In order to measure savings in energy, a comparison is done between the energy usage measured before and after the implementation of the M&V. But this is not enough since energy usage is also dependant on building conditions and hence measurement may require adjustments in the analysis of measured data. Weather and occupancy are examples of factors that regularly change. To assess the effectiveness of the retrofit alone, the influence of these confounding factors must be eliminated through a process of normalization and adjustments. Relationships shall be found between energy use and these factors to remove the influence of the factors from the energy savings measurement. These relationships are usually determined through data analysis. Upon analysing the data, modifications are made to the building to conserve energy or manage demand. These modifications are called energy conservation measures (ECM). ECMs can be of different types, changes to the equipment in the building, operation and maintenance procedures, software, and training to staff and employees.

A typical M&V process may include the following activities:

- a) Installation of metering devices,
- b) Gathering and screening of data,
- c) Development of a computation method with acceptable accuracy,
- d) Computation of measured data,

- e) Reporting on analysis and conclusions, and
- f) Third party verification.

For efficient measurement and verification, it is important to develop an M&V Plan which is specific to a project or site and is a result of the deliberations and negotiations between the project stakeholders (implementer, owner, investor, regulator, etc) which limits its applicability to the specific project for which it has been developed. It captures the project and individual energy conservation measure boundary, assumptions, engineering calculations/equations, metering infrastructure to be deployed, parameters to be monitored and measured or stipulated, along with their frequency or basis, and agreed upon by all stakeholders.

Most facility managers use building automation system for monitoring and maintenances though it has applications in control of HVAC system as well. The BAS stores and analyses building data to produce reports and dashboards that help facility manager keep track of the energy consumption and other operational data points. The live data stream provided by the BAS is also used to reduce or prevent unwanted events in the future. The real value of data from BAS is in its ability to provide information to anyone, right from an energy auditor or facility manager to the top management, thereby enabling proactive management of building operation.

15 TESTING, COMMISSIONING AND PERFORMANCE VALIDATION

15.1 Inspection of Materials and Equipment

15.1.1 All materials and equipment delivered to site shall be compared with documented and approved specifications and shall be found acceptable to the owner.

15.1.2 Physical properties such as thickness, malleability, test pressure, etc, shall be verified from manufacturer's test certificates. Where test certificates by independent test houses are specified, these shall be produced for acceptance. Agreed lot sizes shall be inspected before use at site.

15.1.3 Testing of equipment shall be done at the (manufacturer's) factory by factory personnel and shall be witnessed by owner's representative, if desired by the owner, and agreed by the contractor/manufacturer.

15.1.4 Equipment test certificates for pressure test, capacity test or any other specified test, shall also be produced and accepted by the owner before the said equipment is taken up for erection/installation.

15.1.5 Agreed method of inspection shall be properly recorded and results of the inspection shall be preserved

by the contractor as a record during currency of the contract.

15.1.6 All metering/measuring instruments used for commissioning and testing, shall be calibrated and certificate of calibration shall be on record.

15.2 Cleaning and Stage-Wise Inspection of Work

15.2.1 All equipment, ancillaries, pipes, ducts, insulation material, etc, shall be cleaned prior to use. Cleaning of piping system, duct work, etc, shall be done by an approved and trained agency and the method of cleaning shall be submitted for approval before work is carried out.

15.2.2 Tests on ducts and pipes shall be done in sections, as per approved schematics. Test pressures and applicable standards shall be proposed by the contractor and approved by owner. Once the approval is received, contractor shall prepare and submit testing schedules indicating the sections or circuits where testing is proposed. Contractor shall depute competent staff to supervise testing and arrange for the owner or his representative to witness the testing.

15.2.3 Testing of duct work shall be carried out in manageable sections, and subsequently the entire duct length shall be tested complete with all air outlets in place. For testing, it is recommended to isolate the ductwork at branch damper locations. Contractor shall refer to the commissioning authority and provide adequate number of test points at appropriate locations, as required.

15.2.4 Pipe work shall be tested in parts, floor by floor or zone by zone and by risers which can be isolated by valves.

15.2.5 Cabling and control wiring shall be tested as one complete unit.

15.3 Readiness for Testing

15.3.1 Final pressure testing and leak testing of all piping and ducting systems shall be done and it shall be ensured that any blank offs introduced during testing, have been removed.

15.3.2 All equipment shall be made ready to run. All fan and pump shipping bolts shall be removed and each equipment shall be made ready to start.

15.3.3 For all major equipment such as chiller, VRF unit, cooling tower, air handler, pump ventilation fan, etc, manufacturer or his authorized representative shall certify that the equipment is ready to start.

15.4 Testing

Each components of central air conditioning plant shall be tested for performance as per **15.4.1** to **15.4.4**

15.4.1 Testing of Chiller

Upon completion of installation, the water chilling unit shall be tested for performance. The capacity, in kcal/h (TR), shall be calculated from measurement of temperature difference and flow rate of water in chiller. Power consumption shall be checked from current measurement of the motor which should include the compressor motor as well as fan motor. All calculated and measured values shall match with those provided in technical submittal of chiller.

15.4.2 Testing of Pump

Upon completion of installation, capacity of the pump shall be checked by measuring water flow, using the balancing valve in full open position, motor current and pressure differential between the inlet and outlet. The readings shall be compared with actual performance identified in the technical submittal of the pump.

15.4.3 Testing of Cooling Tower

Upon completion of installation, the cooling tower shall be tested for performance. The capacity, in kcal/h (TR), shall be calculated from measurement of temperature difference, approach to ambient wet-bulb, and the flow rate of water in condenser. The power consumption shall be checked from current measurement of the motor. All calculated and measured values shall match the data given with the technical submittal of cooling tower.

15.4.4 Testing of AHU

Upon completion of installation, the AHU shall be tested for performance. Capacity shall be verified by measurement of air flow (m³/h) at fan discharge, and power consumption from current drawn for fan motor, measured values shall match with the data given by vendor with the technical submittal of each AHU.

15.5 Pre-Commissioning Inspection

Commissioning and performance validation shall be attempted only after completion of staged tests as well as part pressure tests and results shall be recorded and certified by the contractor.

15.6 Commissioning

Commissioning shall mean putting the equipment or system into active service for the use intended by the owner.

15.6.1 For a window (unitary) air conditioner, or split air conditioner, package unit and VRF unit, this shall involve connecting the unit (after installation) to a suitably sized power socket, switching it on and recording the temperature in various parts of the room. The process will also involve checking whether the

unit's promised features such as auto-swing etc, are working properly and also whether the compressor switches off after the desired temperature is achieved. The air flow from the unit shall be measured using an anemometer and compared with the manufacturer's rating listed in their catalogue. The sound level at a distance of 1 m away from the unit shall be measured and recorded.

15.6.2 For a central air conditioning plant or a mechanical ventilation system, the process shall involve a systematic procedure to ensure that the plant performs as per the design parameters and shall include instructing the concerned personnel in proper operation of the plant. Hand over procedure shall include compiling operation manuals for the equipment, service schedule, spare parts list, recommended log recording sheet and regular operation and maintenance procedures; all these shall be made available to the owner.

15.6.2.1 Commissioning engineer should preferably be involved right from the design stage and his/her inputs should be taken while designing and laying out the plant as well as while choosing the control and monitoring system, including the measurement and verification points.

15.7 Scope of Commissioning Activity for Central Air Conditioning System

15.7.1 Commissioning activity shall include the following:

- a) Testing, adjusting, and balancing of air side system;
- b) Testing, adjusting, and balancing of chilled water and piping system;
- c) Measurement of final operating parameters of HVAC system;
- d) Sound measurement of equipment where specified;
- e) Vibration measurement of equipment where specified; and
- f) Testing, adjusting and balancing of smoke control system, exhaust, and fresh air or pressurization system.

15.7.2 The testing, commissioning, and performance validation activities shall be carried out by qualified personnel. The services shall be performed by a third party commissioning agent (independent of the HVAC designer and HVAC works contractor), where so specified.

Necessary documents, drawings and data shall be provided to the commissioning team and manpower for operation of the system shall be provided by the contractor.

15.7.3 Commissioning shall be a systematic process confirming that building systems have been installed, started, and consistently operated in strict accordance with the contract documents. A documentary proof that all systems are complete and functioning in accordance with the contract documents shall be provided to owner's operating personnel. Commissioning shall include seasonal tests, if specified and approved by the owner.

15.7.4 The commissioning engineer shall prepare a documented plan which shall be approved by the owner. The structure, schedule, and co-ordination plan of the commissioning process from the construction phase through the warranty period, shall satisfy the owner's requirements.

15.7.5 Static inspection of material and component tests that verify proper installation of equipment (for example, belt tension, oil levels, labels affixed, gauges in place, sensors calibrated, etc) shall be approved as complete, and shall be submitted with the request for start-up.

15.7.6 The activities where equipment is initially energized, tested, and operated shall be completed prior to functional performance tests (FPT).

15.7.7 Functional performance test shall mean testing of dynamic functions and operation of equipment and systems. System shall be tested under various modes such as low cooling load, high cooling load, varying ambient condition, power failure, life safety condition, etc, as specified. Functional performance tests shall establish that the system is performing as designed, under these conditions.

15.7.8 Test of dynamic interactive functions and operation of multiple systems under various modes, such as fire alarm and emergency situation, life safety condition, power failure, etc, shall be carried out, as specified. Systems shall be integrally operated through all specified sequences of operation. Components shall be verified to be responding in accordance with contract documents. Integrated system tests shall provide verification that the integrated system will properly function according to the contract documents, under all situations, and shall comply with the relevant fire and safety requirement.

15.7.9 Integrated system test procedure and commissioning protocols and instructions, fully describing system configurations and steps required to determine if the interacting systems are performing and functioning properly, shall be provided by the commissioning engineer. HVAC contractor shall prepare these procedures to document integrated system test.

15.7.10 Functional performance, or integrated system performance tests may be deferred due to partial

occupancy, partial equipment load, seasonal requirement, or other site conditions that prohibit the test from being performed, prior to acceptance. Such deferment shall record owner's confirmation and shall also indicate the tentative dates when the tests will be carried out.

15.7.11 Deficiency shall mean a condition of a component, piece of equipment or system that is not in compliance with contract documents.

15.8 Following is an example of the various steps in the commissioning process of a vapour compression type air conditioning system:

- a) Check and confirm that working pressures and temperatures are in line with those specified in design.
- b) Check compressor oil level, oil should not be foaming.
- c) Check compressor body temperature.
- d) Check for liquid flood back.
- e) Check air and water flow through condenser and evaporator.
- f) Check motor current and body temperature.
- g) Check refrigerant charge.
- h) Clean/Replace liquid and suction strainers till they remain clean after usage.
- j) Check superheat at expansion valve.
- k) Set the safety controls and confirm their operation.
- m) Check the piping for any excessive vibration.
- n) Ensure that current drawn by all motors is within motor rating.
- p) Check air distribution system, do air balancing and ensure uniform temperature in all air conditioned spaces.
- q) Verify and balance chilled water flow through various sections of the system, and then the entire length of the piping.
- r) Check the cooling tower operation and make sure wet-bulb approach is within specified limit.
- s) Ensure that guards are provided on all rotating parts.
- t) Initiate regular 'log' readings.
- u) Operating and maintenance (O&M) manual as per requirements of the technical specifications shall be made available to the owner by the contractor. The contractor shall ensure that the O&M manual content, as built drawings and specifications, component submittal drawings, and other pertinent documents, are available with the owner for review.

15.9 Performance validation involves verification that the system performs as per design parameters. The design parameters may include,

- a) temperature and relative humidity;
- b) chilled water or brine temperature and flow rate;
- c) maximum ambient dry-bulb and wet-bulb temperature;
- d) occupancy in conditioned area;
- e) pressure drop across condenser/chiller;
- f) water flow rate through condenser/chiller;
- g) entering and leaving water temperature for condenser/chiller;
- h) chilled water flow rate across cooling coils in AHU;
- j) pressure drop across cooling coils;
- k) compressor speed;
- m) evaporating/condensing temperature/pressure;
- n) current drawn by motors;
- p) air flow rate across cooling coil of AHU;
- q) fresh air quantity;
- r) apparatus dew point, if specified;
- s) DB/WB temp of air entering/leaving the cooling coil;
- t) WB approach of cooling tower; and
- u) power consumption, in kWh.

NOTE — The above is not a comprehensive list. Depending on type of plant and application, the parameters may vary. The parameters to be recorded should be as per design data for the particular plant and as agreed to between the owner and the contractor.

15.10 For individual components of an HVAC system following are the critical parameters.

- a) *Water cooled condenser:*
 - 1) Water flow rate as established by pressure drop across the condenser;
 - 2) Temperature rise; and
 - 3) Condensing temperature and pressure (leaving temperature difference).
- b) *Air cooled condenser:*
 - 1) Air flow rate across the condenser; and
 - 2) Condensing temperature and pressure (leaving temperature difference).
- c) *Chiller:*
 - 1) Water or brine flow rate as established by pressured drop across chiller; and
 - 2) Temperature drop.

d) *Compressor:*

- 1) Oil pressure; and
- 2) Suction/discharge pressures.

e) *Pumps for condenser/chilled water:*

- 1) Water flow rate as established from pump curves based on suction/discharge pressure; and
- 2) Pump motor current.

f) *Cooling tower:*

- 1) Wet-bulb approach.

g) *Air handling unit:*

- 1) Pressure drop through cooling coil;
- 2) Water flow through the cooling coil;
- 3) DB/WB temperature of entering/leaving air; and
- 4) Air flow rate at fan discharge.

h) *Air distribution system:*

- 1) Room conditioners at various places in the room. Temperature rise from AHU units to tail end of duct;
- 2) Draft in occupied zones (between 15 m/min to 30 m/min); and
- 3) Noise level.

15.11 Objectives of performance validation shall be to,

- a) verify conformity to design;
- b) establish fluid flow rates, operating temperatures and pressures;
- c) test all electrical installations for earthing continuity and earth resistance;
- d) verify electrical consumption for each motor and for the plant as a whole;
- e) establish operating sound levels;
- f) check for abnormal vibration;
- g) adjust and balance all parameters to design levels; and
- h) record and report results in a specified format.

15.12 Controls and Safety Cut-Outs

Operation of all controls and safety cut-outs should be demonstrated during the commissioning process and results should be recorded.

15.13 Calibration of Instruments

All measuring instruments used during the commissioning process should be calibrated, either by an independent calibration agency or in comparison with a calibrated gauge. Calibration certificate of all instruments should be available on record.

15.14 Handover Procedure

15.14.1 Handover documentation should include all information that the user will need to operate the equipment efficiently and economically. It should include recorded reading of all factory and site testing, including the calibration certificates of measuring instruments, as well as details of all control settings.

15.14.2 Following are the requirements of handover documentation (as applicable from case to case):

- a) Description of the installation, schedule of equipment;
- b) Heat load calculations and equipment selection details;
- c) Schematic drawings for chilled water/condenser water;
- d) Schematic drawings for exhaust and pressurization systems;
- e) As-built drawings including air distribution layouts;
- f) Operations and maintenance manuals for all equipment/controls/ instrumentation;
- g) Manufacturer's spare parts list and ordering instructions;
- h) Test certificates/test results, as required;
- j) Commissioning readings countersigned by commissioning authority;
- k) Guarantee certificate and service escalation matrix; and
- m) List of all accessories, tools, spares handed over with system.

15.15 Operation and Maintenance

Operation of the plant shall include a continuous vigilance on the performance of the system and day-to-day routine maintenance.

The operating procedure shall be as given in **15.15.1** to **15.15.5**. The maintenance procedure shall be as laid down in **15.15.6**.

15.15.1 Before starting the plant, the operator shall ensure that,

- a) all the valves in the refrigeration system, condenser water lines and chilled water lines are open, except those of the standby items of equipment.
- b) there is sufficient water in the cooling tower basin and the make-up water system is working satisfactorily.
- c) the make-up water system to the expansion tank of the chilled water circuit is working and there is a regular water supply. Water is lost from the chilled water system through pump

gland drips. If the level in the expansion tank is not maintained, air can enter the chilled water system, affecting the system performance substantially. It can even lead to freeze up of the chiller.

- d) all the air filters and water strainers are clean. Any dirty filter and/or the blocked strainer shall be cleaned.
- e) all doors and windows of the air conditioned/refrigerated area are closed.
- f) the crankcase of the compressor is warm (to the physical touch). If it is not warm, defects in the crankcase heater and/or circuit should be checked for. The compressor shall not be started until the defect is rectified and the crankcase warms up, else it will result to poor lubrication, thereby substantially reducing the life of the bearings of the compressor.
- g) the supply voltage is within permissible limits. The windings of the motors can get affected, if run on low voltage conditions.

15.15.2 The starting sequence shall be as follows:

- a) Switch 'ON' the mains. Observe the voltage. If it is less than the permissible level, do not start any component of the system.
- b) Start air handling unit motors (all dampers have to be checked based on their specific application).
- c) Start condenser water pumps. Check that sufficient water pressure is obtained.
- d) Start cooling tower fan.
- e) Start chilled water pumps and check the pressure.
- f) Switch 'ON' the compressor control switch.
- g) Start the compressor motor.

15.15.3 Following aspects require special attention:

- a) In the compressor with oil pump, the compressor oil pressure should build up as the compressor is started. Check that correct net oil pressure is built up.
- b) Check the oil level in the oil sight glass of the compressor. The oil level should be about 40 to 50 percent of the sight glass. In operation, certain amount of oil gets entrained in the refrigerant vapour in the compressor and is carried to the system along with the refrigerant.
- c) After the plant operation has stabilized, check all the pressures and temperatures and ensure that the system is working satisfactorily.
- d) Record periodically the readings of temperature, pressure, current and other required data in the log sheet.

- e) Check for any unusual noise/vibration in the plant. If something unusual is noticed, trace out the reason for it and rectify the cause.
- f) During the operation of the system, if any major component stops suddenly, trace out its reason, before starting the component/system again.

15.15.4 The stopping sequence of the system shall be as follows:

- a) Switch off the compressor on the low pressure switch, as the system gets pumped down.
- b) Switch off the power supply to compressor.
- c) Check that the crankcase electric heater comes on as soon as compressor stops and ensure that the heater is working.
- d) Stop chilled water pumps.
- e) Stop air handling units.
- f) Stop condenser water pumps and cooling tower fans.

15.15.5 Following are standard operating instructions which the operator should follow.

- a) In case stand-by chiller, pumps, etc, are provided, systematically change over the stand-by components, periodically. This will ensure uniform wear and tear of the system. Further, this also helps in ensuring that all equipment is in good shape and the stand-by is in working condition.
- b) Do not switch off the main switch on the main electrical board or switch off any component of the system, when the plant is in operation.
- c) All the water valves in the system shall be kept open and need not be closed, unless specifically instructed by designer. But it is essential to close and open each valve periodically to ensure that the valves work and are not stuck by scale formation or dirt accumulation.
- d) Keep the plant room clean. Do not use the plant room, particularly the air handling unit rooms for storage.

15.15.6 Following are the important day-to-day maintenance work which shall be attended to:

- a) *Clean the air filters* — A dirty air filter reduces the plant capacity. If not cleaned regularly the

filter gets fully loaded with dirt and this dirt can pass on to the cooling coil. In dusty environment, it may be necessary to clean the air filters more often. The filters shall be replaced when cleaning is no longer effective.

- b) *Leak testing for refrigerant leak* — Even a minute leak can cause poor oil return, heating of the compressor and ultimately leading to poor refrigeration.
- c) *Water pump (packed) glands* — Certain amount of water drip through the gland is necessary to keep the gland cool. But if the drip develops into a regular flow, it is an indication that the gland is not holding. The gland nuts may be tightened to reduce the leak. If this does not improve the situation, the gland packing should be replaced.
- d) *Clean the water strainers* — A clogged strainer reduces the water flow rate and thus affect the plant performance.
- e) *Belt tension of belt drives* — Check the tension of belts and tighten whenever found loose. A loose belt reduces transmission efficiency.
- f) Check the spray of the cooling tower nozzles.
- g) *Drain, clean and refill the cooling tower sump* — Cooling tower, being in the open, collect a lot of dust and muck. Hence, the tower shall be cleaned at least once in a week.
- h) For adequate heat transfer, it is necessary that tubes of a shell and tube condenser as well as those of a flooded chiller are kept clean. It is recommended that tube cleaning is carried out once in 6 months in case of a condenser and as often as necessary in case of chiller. It is also recommended that automatic in-line chemical dosing systems may be installed which inhibit scale formation in the tubes.
- j) It is the pressure gauges and thermometers which give the correct indication of the plant performance and condition. Therefore, it should be ensured that these are in good order and are periodically calibrated.
- k) Analyse the pressure and temperature readings of the system from the log book and ensure that these conform to design parameters. Corrective action should be promptly taken when the readings show even a minor discrepancy.

ANNEX A
(Clause 6.2)

TEMPERATURE DESIGN CONDITIONS USING ADAPTIVE MODELS¹⁾

SI No.	Mode of Operation →	Naturally Ventilated		Mixed Mode		Air Conditioned			
	Approach →	Operative Temperature °C		Operative Temperature °C		Air Temperature °C		Standard Effective Temperature °C	
	City ↓	90 Percent Upper Band	90 Percent Lower Band	90 Percent Upper Band	90 Percent Lower Band	90 Percent Upper Band	90 Percent Lower Band	90 Percent Upper Band	90 Percent Lower Band
(1)	(2)	(3)	(4)	(5)	(6)	(7)	(8)	(9)	(10)
1)	Ahmedabad	32.0-25.5	27.2-20.7	31.1-26.7	24.1-19.7	27.5-26.2	24.5-23.2	26.0-25.8	24.0-23.8
2)	Akola	32.0-26.4	27.2-21.6	31.2-27.2	24.2-20.2	27.5-26.4	24.5-23.4	26.0-25.8	24.0-23.8
3)	Allahabad	32.0-23.6	27.2-18.8	31.3-25.7	24.3-18.7	27.5-26.0	24.5-23.0	26.0-25.7	24.0-23.7
4)	Amritsar	32.0-22.0	27.2-17.2	30.4-25.0	23.4-18.0	27.3-25.9	24.3-22.9	26.0-25.7	24.0-23.7
5)	Aurangabad	32.0-25.7	27.2-20.9	30.5-26.8	23.5-19.8	27.3-26.3	24.3-23.3	26.0-25.8	24.0-23.8
6)	Barmer	32.0-24.6	27.2-19.8	31.2-26.2	24.2-19.2	27.5-26.1	24.5-23.1	26.0-25.8	24.0-23.8
7)	Belgaum	30.7-26.7	25.9-21.9	29.4-27.3	22.4-20.3	27.0-26.4	24.0-23.4	25.9-25.8	23.9-23.8
8)	Bengaluru	30.7-26.5	25.9-21.7	29.4-27.2	22.4-20.2	27.0-26.4	24.0-23.4	25.9-25.8	23.9-23.8
9)	Bhagalpur	32.0-25.2	27.2-20.4	30.2-26.6	23.2-19.6	27.2-26.2	24.2-23.2	26.0-25.8	24.0-23.8
10)	Bhopal	32.0-24.5	27.2-19.7	31.1-26.2	24.1-19.2	27.5-26.1	24.5-23.1	26.0-25.8	24.0-23.8
11)	Bhubaneswar	32.0-26.6	27.2-21.8	30.6-27.3	23.6-20.3	27.3-26.4	24.3-23.4	26.0-25.8	24.0-23.8
12)	Bhuj	32.0-25.4	27.2-20.6	30.5-26.6	23.5-19.6	27.3-26.2	24.3-23.2	26.0-25.8	24.0-23.8
13)	Bikaner	32.0-22.3	27.2-17.5	31.3-25.0	24.3-18.0	27.5-25.9	24.5-22.9	26.0-25.7	24.0-23.7
14)	Chennai	32.0-28.7	27.2-23.9	30.7-28.3	23.7-21.3	27.4-26.7	24.4-23.7	26.0-25.9	24.0-23.9
15)	Chitradurga	31.2-27.2	26.4-22.4	29.6-27.6	22.6-20.6	27.1-26.5	24.1-23.5	25.9-25.8	23.9-23.8
16)	Dehradun	31.0-22.3	26.2-17.5	29.6-25.0	22.6-18.0	27.0-25.9	24.0-22.9	25.9-25.7	23.9-23.7

ANNEX A — (Continued)

SI No.	Mode of Operation →	Naturally Ventilated		Mixed Mode		Air Conditioned			
	Approach →	Operative Temperature °C		Operative Temperature °C		Air Temperature °C		Standard Effective Temperature °C	
	City ↓	90 Percent Upper Band	90 Percent Lower Band	90 Percent Upper Band	90 Percent Lower Band	90 Percent Upper Band	90 Percent Lower Band	90 Percent Upper Band	90 Percent Lower Band
(1)	(2)	(3)	(4)	(5)	(6)	(7)	(8)	(9)	(10)
17)	Dibrugarh	30.4-23.2	25.6-18.4	29.2-25.5	22.2-18.5	26.9-25.9	23.9-22.9	25.9-25.7	23.9-23.7
18)	Gorakhpur	32.0-22.6	27.2-17.8	30.3-25.2	23.3-18.2	27.2-25.9	24.2-22.9	26.0-25.7	24.0-23.7
19)	Guwahati	30.8-24.2	26.0-19.4	29.4-26.0	22.4-19.0	27.0-26.0	24.0-23.0	25.9-25.8	23.9-23.8
20)	Gwalior	32.0-22.8	27.2-18.0	31.5-25.3	24.5-18.3	27.6-25.9	24.6-22.9	26.0-25.7	24.0-23.7
21)	Hisar	32.0-22.5	27.2-17.7	31.3-25.1	24.3-18.1	27.5-25.9	24.5-22.9	26.0-25.7	24.0-23.7
22)	Hyderabad	32.0-26.8	27.2-22.0	30.3-27.4	23.3-20.4	27.2-26.4	24.2-23.4	26.0-25.8	24.0-23.8
23)	Imphal	29.1-22.1	24.3-17.3	28.6-25.0	21.6-18.0	26.8-25.9	23.8-22.9	25.9-25.7	23.9-23.7
24)	Indore	32.0-24.9	27.2-20.1	30.4-26.4	23.4-19.4	27.3-26.1	24.3-23.1	26.0-25.8	24.0-23.8
25)	Jabalpur	32.0-24.1	27.2-19.3	30.5-26.0	23.5-19.0	27.3-26.0	24.3-23.0	26.0-25.8	24.0-23.8
26)	Jagdalpur	31.4-25.5	26.6-20.7	29.8-26.7	22.8-19.7	27.1-26.2	24.1-23.2	26.0-25.8	24.0-23.8
27)	Jaipur	32.0-23.7	27.2-18.9	31.2-25.8	24.2-18.8	27.5-26.0	24.5-23.0	26.0-25.7	24.0-23.7
28)	Jaisalmer	32.0-24.3	27.2-19.5	31.1-26.1	24.1-19.1	27.5-26.1	24.5-23.1	26.0-25.8	24.0-23.8
29)	Jamnagar	31.8-25.0	27.0-20.2	30.0-26.4	23.0-19.4	27.1-26.2	24.1-23.2	26.0-25.8	24.0-23.8
30)	Jodhpur	32.0-24.9	27.2-20.1	31.2-26.4	24.2-19.4	27.5-26.1	24.5-23.1	26.0-25.8	24.0-23.8
31)	Jorhat	30.9-23.8	26.1-19.0	29.5-25.8	22.5-18.8	27.0-26.0	24.0-23.0	25.9-25.8	23.9-23.8
32)	Kolkata	32.0-25.7	27.2-20.9	30.1-26.8	23.1-19.8	27.2-26.3	24.2-23.3	26.0-25.8	24.0-23.8
33)	Kota	32.0-24.2	27.2-19.4	31.8-26.0	24.8-19.0	27.6-26.0	24.6-23.0	26.1-25.8	24.1-23.8
34)	Kurnool	32.0-27.8	27.2-23.0	31.1-27.9	24.1-20.9	27.5-26.6	24.5-23.6	26.0-25.9	24.0-23.9
35)	Lucknow	32.0-23.3	27.2-18.5	30.7-25.5	23.7-18.5	27.4-25.9	24.4-22.9	26.0-25.7	24.0-23.7
36)	Mangalore	31.2-28.9	26.4-24.1	29.6-28.4	22.6-21.4	27.1-26.7	24.1-23.7	25.9-25.8	23.9-23.8
37)	Mumbai	31.7-28.5	26.9-23.7	29.9-28.3	22.9-21.3	27.1-26.7	24.1-23.7	26.0-25.9	24.0-23.9

ANNEX A — (Concluded)

Sl No.	Mode of Operation →	Naturally Ventilated		Mixed Mode		Air Conditioned			
	Approach →	Operative Temperature °C		Operative Temperature °C		Air Temperature °C		Standard Effective Temperature °C	
	City ↓	90 Percent Upper Band	90 Percent Lower Band	90 Percent Upper Band	90 Percent Lower Band	90 Percent Upper Band	90 Percent Lower Band	90 Percent Upper Band	90 Percent Lower Band
(1)	(2)	(3)	(4)	(5)	(6)	(7)	(8)	(9)	(10)
38)	Nagpur	32.0-26.1	27.2-21.3	31.5-27.0	24.5-20.0	27.6-26.3	24.6-23.3	26.0-25.8	24.0-23.8
39)	Nellore	32.0-28.5	27.2-23.7	31.0-28.3	24.0-21.3	27.4-26.7	24.4-23.7	26.0-25.9	24.0-23.9
40)	New Delhi	32.0-22.0	27.2-17.2	30.7-25.0	23.7-18.0	27.4-25.9	24.4-22.9	26.0-25.7	24.0-23.7
41)	Panjim	31.5-29.4	26.7-24.6	29.8-28.7	22.8-21.7	27.1-26.8	24.1-23.8	26.0-25.9	24.0-23.9
42)	Patna	32.0-23.8	27.2-19.0	30.3-25.8	23.3-18.8	27.2-26.0	24.2-23.0	26.0-25.8	24.0-23.8
43)	Pune	31.1-25.7	26.3-20.9	29.6-26.8	22.6-19.8	27.0-26.3	24.0-23.3	25.9-25.8	23.9-23.8
44)	Raipur	32.0-25.7	27.2-20.9	31.1-26.8	24.1-19.8	27.5-26.3	24.5-23.3	26.0-25.8	24.0-23.8
45)	Rajkot	32.0-26.3	27.2-21.5	30.8-27.1	23.8-20.1	27.4-26.3	24.4-23.3	26.0-25.8	24.0-23.8
46)	Ramagundam	32.0-27.0	27.2-22.2	31.3-27.4	24.3-20.4	27.5-26.4	24.5-23.4	26.0-25.8	24.0-23.8
47)	Ranchi	31.7-23.7	26.9-18.9	29.9-25.8	22.9-18.8	27.1-26.0	24.1-23.0	26.0-25.7	24.0-23.7
48)	Ratnagiri	31.0-28.6	26.2-23.8	29.5-28.3	22.5-21.3	27.0-26.7	24.0-23.7	25.9-25.8	23.9-23.8
49)	Raxaul	31.3-23.1	26.5-18.3	29.7-25.5	22.7-18.5	27.1-25.9	24.1-22.9	25.9-25.7	23.9-23.7
50)	Saharanpur	31.6-22.0	26.8-17.2	29.8-25.0	22.8-18.0	27.1-25.9	24.1-22.9	26.0-25.7	24.0-23.7
51)	Shillong	25.7-22.0	20.9-17.2	26.8-25.0	19.8-18.0	26.3-25.9	23.3-22.9	25.8-25.7	23.8-23.7
52)	Solapur	32.0-28.1	27.2-23.3	30.6-28.1	23.6-21.1	27.3-26.6	24.3-23.6	26.0-25.9	24.0-23.9
53)	Surat	32.0-27.2	27.2-22.4	30.2-27.6	23.2-20.6	27.2-26.5	24.2-23.5	26.0-25.8	24.0-23.8
54)	Tezpur	30.7-24.4	25.9-19.6	29.4-26.1	22.4-19.1	27.0-26.1	24.0-23.1	25.9-25.8	23.9-23.8
55)	Thiruvananthapuram	31.0-29.6	26.2-24.8	29.5-28.8	22.5-21.8	27.0-26.8	24.0-23.8	25.9-25.8	23.9-23.8
56)	Tiruchchirapalli	32.0-28.9	27.2-24.1	30.5-28.5	23.5-21.5	27.3-26.7	24.3-23.7	26.0-25.9	24.0-23.9
57)	Varanasi	32.0-22.7	27.2-17.9	30.6-25.2	23.6-18.2	27.3-25.9	24.3-22.9	26.0-25.7	24.0-23.7
58)	Veraval	31.6-27.5	26.8-22.7	29.9-27.7	22.9-20.7	27.1-26.5	24.1-23.5	26.0-25.8	24.0-23.8
59)	Vishakhapatnam	31.9-27.6	27.1-22.8	30.0-27.8	23.0-20.8	27.2-26.5	24.2-23.5	26.0-25.9	24.0-23.9

1) These temperature design conditions are annual values of 99.6 and 0.4 percentile for 90 percent comfort band based on typical weather data

LIST OF STANDARDS

The following list records those standards which are acceptable as 'good practice' and 'accepted standards' in the fulfillment of the requirements of the Code. The latest version of a standard shall be adopted at the time of enforcement of the Code. The standards listed may be used by the Authority for conformance with the requirements of the referred clauses in the Code.

In the following list, the number appearing in the first column within parentheses indicates the number of the reference in this Section.

<i>IS No.</i>	<i>Title</i>	<i>IS No.</i>	<i>Title</i>
(1) 3615 : 2007	Glossary of terms used in refrigeration and air conditioning (<i>first revision</i>)	(7) 1391 (Part 1) : 1992	Specification for room air conditioners: Part 1 Unitary air conditioners (<i>second revision</i>)
(2) IS/ISO 817	Refrigerants — Designation and safety classification of refrigerants (<i>second revision</i>) (<i>under print</i>)	(8) 1391 (Part 2) : 1992	Specification for room air conditioners: Part 2 Split air conditioners (<i>second revision</i>)
(3) 8188 : 1999	Code of practice for treatment of water for cooling towers (<i>first revision</i>)	(9) 8148 : 2003	Specification for packaged air conditioners (<i>first revision</i>)
(4) 655 : 2006	Specification for air ducts (<i>second revision</i>)	(10) 3315 : 1994	Specification for evaporative air coolers (desert coolers) (<i>second revision</i>)
(5) 277 : 2003	Specification for galvanized steel sheets (plain and corrugated) (<i>sixth revision</i>)	(11) 661 : 2000	Code of practice for thermal insulation of cold storage (<i>third revision</i>)
(6) 737 : 2008	Specification for wrought aluminium and aluminium alloy sheet and strip for general engineering purposes (<i>fourth revision</i>)	(12) 12976 : 1990	Code of practice for solar water heating systems
		(13) 3103 : 1975	Code of practice for industrial ventilation (<i>first revision</i>)
		(14) 1239 (Part 1) : 2004	Specification for steel tubes, tubulars and other wrought steel fittings: Part 1 Steel tubes (<i>sixth revision</i>)
		(15) 3589 : 2001	Specification for steel pipes for water and sewage (168.3 to 2 540 mm outside diameter) (<i>third revision</i>)
		(16) 4831 : 1968	Recommendation on units and symbols for refrigeration
		(17) 5 : 2007	Colours for ready mixed paints and enamels (<i>sixth revision</i>)

NATIONAL BUILDING CODE OF INDIA

PART 8 BUILDING SERVICES

Section 4 Acoustics, Sound Insulation and Noise Control

BUREAU OF INDIAN STANDARDS

CONTENTS

FOREWORD	... 3
1 SCOPE	... 5
2 TERMINOLOGY	... 5
3 PLANNING AND DESIGN AGAINST OUTDOOR NOISE	... 8
4 PLANNING AND DESIGN AGAINST INDOOR NOISE	... 12
5 RESIDENTIAL BUILDINGS	... 12
6 EDUCATIONAL BUILDINGS	... 14
7 HOSPITAL BUILDINGS	... 17
8 OFFICE BUILDINGS	... 19
9 HOTELS AND HOSTELS	... 21
10 INDUSTRIAL BUILDINGS	... 22
11 LABORATORIES AND TEST HOUSES	... 26
12 MISCELLANEOUS BUILDINGS	... 27
13 NOISE FROM BUILDING SERVICES	... 29
ANNEX A NOISE CALCULATIONS	... 30
ANNEX B SPECIFICATION OF SOUND INSULATION	... 32
ANNEX C NOISE RATING	... 34
ANNEX D OUTDOOR NOISE REGULATIONS IN INDIA	... 35
ANNEX E SPECIAL PROBLEMS REQUIRING EXPERT ADVICE	... 35
ANNEX F AIRBORNE AND IMPACT SOUND INSULATION	... 36
ANNEX G BASIC DESIGN TECHNIQUES FOR NOISE CONTROL IN AIR CONDITIONING, HEATING AND MECHANICAL VENTILATION SYSTEM	... 43
ANNEX H SUGGESTED EQUIPMENT NOISE DATA SHEET	... 44
LIST OF STANDARDS	... 45

FOREWORD

This Code (Part 8/Section 4) covers the acoustical, sound insulation and noise control requirements in buildings. Emphasis is laid on planning of buildings *vis-a-vis* its surroundings to reduce noise, and in addition, sound insulation aspects of different occupancies are covered for achieving acceptable noise levels.

This Section was first published in 1970 and was subsequently revised in 1983 and 2005. Some of the important changes in the 1983 version included: specifying of approximate measured noise levels due to various types of traffic (air, rail and road) conditions; elaboration of planning and design features of buildings against outdoor noise; modification of impact sound insulation in residential buildings and hearing damage risk criteria in industrial buildings; recommendations regarding planning of open plan schools against noise; planning and design aspects of hotels and hostels, laboratories and test houses, and other miscellaneous buildings, and planning of office buildings with light weight partitions; and elaboration of the public address system to cover public address system at passenger terminals.

Some of the important changes in the 2005 version included: addition of large numbers of important definitions in line with the existing international practice of usage of terms in the field of acoustics, sound insulation and noise control; inclusion of a new clause on highway noise barrier under provisions on planning and design against outdoor noise; deletion of the clause on public address system; addition of a new clause on cinema; and deletion of existing appendices on 'Constructional Measures for Sound Insulation of Buildings' and 'Sound Insulation values for various types of Materials and Construction'; and addition of eight new informative annexes on noise calculations, specification of sound insulation, noise rating, outdoor noise regulations in India, special problems requiring expert advice, airborne and impact sound insulation, basic design techniques for noise control in HVAC and suggested equipment noise data sheet.

This revision has been brought out to incorporate changes based on the experience gained during usage of the last version of this Section. Following are the significant changes made in this revision:

- a) Definitions of various existing terms have been reviewed and updated, wherever required, and of new terms have been added, such as noise criteria, sound level difference, ground-borne and structure-borne noise.
- b) A new clause on construction noise has been introduced.
- c) The provision relating to noise control in open plan schools has been deleted, owing to the changed scenario.
- d) In case of auditoria and theatres, provision for effective isolation of mechanical equipment such as lifts from the building structure to help avoid noise transmission, has been included.
- e) Also, in case of auditoria and theatres, requirement for adequate damping under light weight metal roofs, with an additional light weight under deck noise sound barrier to reduce rainfall generated noise, has been included.
- f) Reverberation time of assembly halls in schools corresponding to 'Maximum for noise control (empty)' has been modified.
- g) Reverberation times of classrooms in schools have been modified.
- h) Requirement of insulation (R_w) for walls or partitions between rooms in hospitals have been modified.
- j) Recommended maximum reverberation time for very large offices and for canteens have been modified.
- k) Recommended sound isolation value (D_w) between one room and another room in office has been modified.
- m) Recommended sound isolation value (D_w) for clerical offices in which noise does not constitute a major nuisance has been modified.
- n) Provision for assembly for partition between guest rooms and between rooms, corridors and floors, in hotels, has been modified.

- p) Examples of common types of wall and floor construction with sound insulation have been reviewed and modified, wherever required.
- q) Provisions have been updated to take care of the requirements of persons with disabilities.

There are two types of noises, that is, airborne and structure-borne noise. To reduce the intensity of airborne noise, sound absorbent materials may be used. An absorbent material is one which reduces the intensity of sound reflected from its surface. It may be applied to walls, floors, ceilings or used as furnishings to reduce the sound level by absorption. However, the materials selected for sound absorption shall be consistent with fire safety requirements of the buildings.

To reduce the transmission of airborne noise, sound insulating materials may be used. Sound insulating materials block the passage of noise through them by virtue of their mass and physical properties. The extent of noise reduction provided by a single homogeneous panel is proportional to the logarithm of mass per unit area. For high values of sound insulation, normally heavy panels are required. Thin sheets of materials do not have adequate mass for providing any appreciable sound transmission loss by themselves. However, when thin sheet materials are used in a double panel construction with an intervening air cavity, this special construction can give extremely high sound transmission loss values considering the mass of the partition, if designed properly. Porous materials lack the mass required to provide any appreciable sound transmission loss, and readily allow sound at most frequencies to be transmitted through them.

To reduce the transmission of structure-borne noise (such as noise generated by impacts) special construction methods and elastic discontinuity in the structure may be used. Structure-borne noise reduction is effected by corner joints, changes in cross-section, changes in materials, etc, in construction. The reduction by these construction methods is, however, not appreciable especially when a large amount of noise reduction is required over a short distance. In such cases, introduction of an elastic discontinuity in the structure can result in a very large amount of noise reduction. The noise transmission is affected only above a certain lower frequency which depends on the material thickness and the elastic properties of the material. Bonded fibrous materials, rubber elastomers, cork, etc. are suitable for curtailing structure-borne noise transmission.

This Section is largely based on the following standards:

IS 1950 : 1962	Code of practice for sound insulation of non-industrial buildings
IS 3483 : 1965	Code of practice for noise reduction in industrial buildings
IS 4954 : 1968	Recommendations for noise abatement in town planning
IS 11050 (Part 1) : 1984	Rating of sound insulation in buildings and of building elements: Part 1 Airborne sound insulation in buildings and of interior building elements
IS 11050 (Part 2) : 1984	Rating of sound insulation in buildings and of building elements: Part 2 Impact sound insulation
BS 8233 : 2014	Code of practice for sound insulation and noise reduction for buildings

All standards, whether given herein above or cross-referred to in the main text of this Section, are subject to revision. The parties to agreement based on this Section are encouraged to investigate the possibility of applying the most recent editions of the standards.

For the purpose of deciding whether a particular requirement of this Section is complied with, the final value, observed or calculated, expressing the result of a test or analysis, shall be rounded off in accordance with IS 2 : 1960 'Rules for rounding off numerical values (*revised*)'. The number of significant places retained in the rounded off value should be the same as that of the specified value in this Section.

NATIONAL BUILDING CODE OF INDIA

PART 8 BUILDING SERVICES

Section 4 Acoustics, Sound Insulation and Noise Control

1 SCOPE

This Code (Part 8/Section 4) covers requirements and guidelines regarding planning against noise, acceptable noise levels and the requirements for sound insulation in buildings with different occupancies.

2 TERMINOLOGY

For the purpose of this Section, the definitions given below shall apply.

2.1 Ambient Noise — The sound pressure levels associated with a given environment. Ambient noise is usually a composite of sounds from near and far sources, none of which are particularly dominant.

2.2 Audible Frequency Range — The range of sound frequencies normally heard by the human ear. The audible range spans from 20 Hz to 20 000 Hz.

2.3 A-Weighted Sound Pressure, p_A — Value of overall sound pressure, measured in pascal (Pa), after the electrical signal derived from a microphone has been passed through an A-weighting network.

NOTE — The A-weighting network modifies the electrical response of a sound level meter with frequency in approximately the same way as the sensitivity of the human hearing system.

2.4 A-Weighted Sound Pressure Level, L_{pA} — The quantity of A-weighted sound pressure, in decibel (dB), as given by the following formula:

$$L_{pA} = 10 \log_{10} (p_A/p_0)^2$$

where

p_A = A-weighted sound pressure, in pascals (Pa);
and

p_0 = reference sound pressure (20 μ Pa).

NOTE — Measurements of A-weighted sound pressure level can be made with a meter and correlate roughly with subjective assessments of loudness, and are usually made to assist in judging the effects of noise on people. The size of A-weighting in 1/3 octave bands, is shown in Annex A (see A-5). An increase or decrease in level of 10 dBA corresponds roughly to a doubling or halving of loudness.

2.5 Background Noise — The sound pressure levels in a given environment from all sources excluding a specific sound source being investigated or measured.

2.6 Break-In — Unwanted sound transmission into a duct or a quiet environment, from outside.

2.7 Break-Out — Unwanted sound transmission from the inside of a duct or a noisy enclosure, to the outside.

2.8 Broad Band Noise — Spectrum consisting of a large number of frequency components, none of which is individually dominant.

2.9 Cross-Talk — Unwanted sound transmission between one room and another room or space, *via* a duct.

2.10 C_{tr} — Correction term applied against the sound insulation single-number values (R_w , D_w , and $D_{nT,w}$) to provide A-weighting against low frequency performance.

NOTE — The reference values used within the C_{tr} calculation are based on urban traffic noise.

2.11 Decibel — Ten times the logarithm (to the base 10) of the ratio of two mean square values of sound pressure, sound power or sound intensity. The abbreviation for decibel is dB.

2.12 Effective Perceived Noise Level, in Decibel (EPN dB) — The number for rating the noise of an individual aircraft flying overhead is the effective perceived noise level in decibel (EPN dB). The effective perceived noise decibel value takes into account the subjectively annoying effects of the noise including pure tones and duration. In principle, it is a kind of time-integrated loudness level.

2.13 Equivalent Continuous A-Weighted Sound Pressure Level, $L_{Aeq,T}$ — Value of the A-weighted sound pressure level in decibel (dB) of a continuous, steady sound, that within a specified time interval, T , has the same mean squared sound pressure as the sound under consideration that varies with time, and is given by the formula:

$$L_{Aeq,T} = 10 \log_{10} \left(\frac{1}{T} \int_0^T \frac{p_A^2(t)}{p_0^2} dt \right)$$

where

$p_A(t)$ = instantaneous A-weighted sound pressure, in pascal (Pa); and

p_0 = reference sound pressure (20 μ Pa).

NOTE — Equivalent continuous A-weighted sound pressure level is mainly used for the assessment of environmental noise and occupational noise exposure.

2.14 Equivalent Sound Absorption Area of a Room, A — Hypothetical area of a totally absorbing surface without diffraction effects, expressed in square metre (m^2) which, if it were the only absorbing element

in the room, would give the same reverberation time as the room under consideration.

2.15 Façade Level — Sound pressure level measured 1 m to 2 m in front of the façade.

NOTE — Façade level measurements of L_{pA} are usually 2 dB to 3 dB higher than corresponding free-field measurements.

2.16 Free-Field Level — Sound pressure level measured outside, far away from reflecting surfaces.

NOTE — Measurements made 1.2 m to 1.5 m above the ground and at least 3.5 m away from other reflecting surfaces are usually regarded as being free-field measurements. To minimise the effect of reflections the measuring position should be at least 3.5 m to the side of the reflecting surface (that is, not 3.5 m from the reflecting surface in the direction of the source). Estimates of noise from aircraft overhead usually include a correction of 2 dB to allow for reflections from the ground.

2.17 Frequency — The number of cyclical variations per unit time. Frequency is generally expressed in cycles per second (cps) and is also denoted as Hertz (Hz).

2.18 Impact Sound Pressure Level, L_i — Average sound pressure level in a specific frequency band in a room below a floor, when it is excited by a standard tapping machine.

2.19 Indoor Ambient Noise — Pervasive noise in a given situation at a given time, usually composed of noise from many sources, inside and outside the building, but excluding noise from activities of the occupants.

2.20 Insertion Loss (L_{II}) — Insertion loss is generally defined as the difference, in decibels, between two sound pressure levels (or power levels or intensity levels) which are measured at the same point in space before and after a muffler or any other noise control device is inserted between the measurement point and the noise source.

2.21 Noise — Unwanted sound which may be hazardous to health, interferes with communications or is disturbing.

2.22 Noise Exposure Forecast (NEF) — The noise exposure forecast at any location is the summation of the noise levels in EPN dB from all aircraft types, on all runways, suitably weighted for the number of operations during day time and night time.

2.23 Noise Criteria — Numerical indices used to define design goals for the maximum allowable noise in a given space.

2.24 Noise Rating (NR) — Graphical method for rating a noise by comparing the noise spectrum with a family of noise rating curves.

NOTE — Noise rating is described in Annex C.

2.25 Noise Reduction Coefficient (NRC) — A single figure descriptor of the sound absorption property of a material. It is the arithmetic mean of the sound absorption coefficients at 250, 500, 1 000 and 2 000 Hz rounded off to the nearest multiple of 0.05.

2.26 Normalized Impact Sound Pressure Level, L_n — Impact sound pressure level normalized for a standard absorption area in the receiving room.

NOTE — Normalized impact sound pressure level is usually used to characterize the insulation of a floor in a laboratory against impact sound in a stated frequency band (see Annex B).

2.27 Octave Band — Band of frequencies in which the upper limit of the band is twice the frequency of the lower limit.

2.28 Percentile Level, $L_{AN,T}$ — A-weighted sound pressure level obtained using time-weighting 'F', which is exceeded for N percent of a specified time interval.

Example:

$L_{A90,1h}$ is the A-weighted level exceeded for 90 percent of 1 h.

NOTE — Percentile levels, determined over a certain time interval cannot accurately be extrapolated to other time intervals. Time-weighting 'F' or 'S' can be selected on most modern measuring instruments and used to determine the speed at which the instrument responds to changes in the amplitude of the signal. Time-weighting 'F' is faster than 'S' and so its use can lead to higher values when rapidly changing signals are measured.

2.29 Pink Noise — Sound with an uninterrupted frequency spectrum and a power which is steady within frequency band and proportional to centre frequency. An example is constant power level per octave band.

2.30 Pure Tone — A sound emitted at a single frequency.

2.31 Rating Level, L_{Ar}, T_r — Equivalent continuous A-weighted sound pressure level of the noise, plus any adjustment for the characteristic features of the noise.

NOTE — This definition is used for rating industrial noise, where the noise is the specific noise from the source under investigation.

2.32 Reverberation Time, T — Time that would be required for the sound pressure level to decrease by 60 dB after the sound source has stopped.

NOTE — Reverberation time is usually measured in octave or third octave bands. It is not necessary to measure the decay over the full 60 dB range. The decay measured over the range 5 dB to 35 dB below the initial level is denoted by T_{30} and over the range 5 dB to 25 dB below the initial level by T_{20} .

2.33 Sound — A vibrational disturbance, exciting hearing mechanisms, transmitted in a predictable manner determined by the medium through which it propagates. To be audible the disturbance shall have to

fall within the frequency range of 20 Hz to 20 000 Hz.

2.34 Sound Exposure Level, L_{AE} — Level of a sound, of 1 s duration, that has the same sound energy as the actual noise event considered.

NOTES

1 The L_{AE} of a discrete noise event is given by the formula:

$$L_{AE} = 10 \log_{10} \left(\frac{1}{t_0} \int_{t_1}^{t_2} \frac{p_A^2(t)}{p_0^2} dt \right)$$

where

$p_A(t)$ = instantaneous A-weighted sound pressure, in pascal (Pa);

$t_2 - t_1$ = stated time interval in seconds (s) long enough to encompass all significant sound energy of the event;

p_0 = reference sound pressure level (20 μ Pa); and

t_0 = reference time interval (1 s).

2 L_{AE} is also known as L_{AX} (single-event noise exposure level).

2.35 Sound Level Difference, D — Difference between the sound pressure level in the source room and the sound pressure level in the receiving room.

NOTE — D is given by the following formula:

$$D = L_1 - L_2$$

where

L_1 = average sound pressure level in the source room; and

L_2 = average sound pressure level in the receiving room.

2.36 Sound Power — The acoustic power of a sound source, expressed in Watt.

2.37 Sound Power Level (L_w) — The acoustic power radiated from a given sound source as related to a reference power level (typically 10-12 watt) and expressed in decibel as :

$$L_p = 10 \log_{10} \left\{ \frac{W}{10^{-12}} \right\}$$

or

$$L_w = 10 \log W + 120$$

where

W = acoustic power, in watt.

By definition, 1 W therefore corresponds to 120 dB for L_w .

2.38 Sound Pressure, p — Root-mean-square value of the variation in air pressure measured in pascal (Pa), above and below atmospheric pressure, caused by the sound.

2.39 Sound Pressure Level, L_p — Quantity of sound pressure, in decibel (dB), given by the formula:

$$L_p = 10 \log_{10} (p/p_0)^2$$

where

p = root mean square sound pressure in pascals (Pa); and

p_0 = reference sound pressure (20 μ Pa).

NOTE — The range of sound pressures for ordinary sounds is very wide. The use of decibels gives a smaller, more convenient range of numbers. For example, sound pressure levels ranging from 40 dB to 94 dB correspond to sound pressures ranging from 0.002 Pa to 1 Pa. A doubling of sound energy corresponds to an increase in level of 3 dB.

2.40 Sound Receiver — One or more observation points at which sound is evaluated or measured. The effect of sound on an individual receiver is usually evaluated by measurements near the ear or close to the body.

2.41 Sound Reduction Index, R — Laboratory measure of the sound insulating properties of a material or building element in a stated frequency band.

NOTE — For further information see Annex B.

2.42 Sound Source — Equipment or phenomena which generate sound. Source room is the room containing sound source.

2.43 Spectrum — A quantity expressed as a function of frequency, such as sound pressure versus frequency curve.

2.44 Standardized Impact Sound Pressure Level, L'_{nT} — Impact sound pressure level normalized to that in a receiving room having a reverberation time of 0.5 s.

NOTE — Standardized impact sound pressure level is used to characterize the insulation of floors in buildings against impact sound in a stated frequency band (see Annex B).

2.45 Speech Interference Level (SIL) — A descriptor for rating steady noise according to its ability to interfere with conversation between two people. SIL is the arithmetic average of the sound pressure levels in the three octave bands with centre frequencies at 500, 1 000 and 2 000 Hz.

2.46 Standardized Level Difference, D_{nT} — Difference in sound level between a pair of rooms, in a stated frequency band, normalized to a reverberation time of 0.5 s.

NOTE — Standardized level difference takes account of all sound transmission paths between the rooms (see Annex B).

2.47 Structure-Borne Noise and Ground-Borne

NOTE — When elements of a structure vibrate they radiate noise and, if the vibration is high enough, this noise can be audible. Ground-borne and structure-borne noises are rarely an issue outside buildings or structures.

2.47.1 Ground-Borne Noise — Audible noise caused by the vibration of elements of a structure, for which the vibration propagation path from the source is partially or wholly through the ground.

NOTE — Common sources of ground-borne noise include railways and heavy construction work on adjacent construction sites.

2.47.2 Structure-Borne Noise — Audible noise caused by the vibration of elements of a structure, the source of which is within a building or structure with common elements.

NOTE — Common sources of structure-borne noise include building services plant, manufacturing machinery and construction or demolition of the structure.

2.48 Transient Sound — Sound which is audible for a limited period of time, for example, sound from over flight of an airplane.

2.49 Third Octave Band — Band of frequencies in which the upper limit of the band is $2\frac{1}{3}$ times the frequency of the lower limit.

2.50 Threshold of Hearing — The lowest continuous sound pressure level which will create an auditory sensation for the average human ear. Any sound below these levels will be inaudible and any sound above the threshold will vary in loudness dependent on intensity.

2.51 Vibration Isolation — Reduction of force or displacement transmitted by a vibratory source, often attained by use of a resilient mount.

2.52 Wavelength — The length in space of one complete cycle of a sound wave given by:

$$\lambda = \frac{\text{Speed of sound}}{\text{Frequency}} = \frac{(C)}{(f)}$$

2.53 Weighted Level Difference, D_w — Single-number quantity that characterizes airborne sound insulation between rooms but which is not adjusted to reference conditions.

NOTE — Weighted level difference is used to characterize the insulation between rooms in a building as they are; values cannot normally be compared with measurements made under other conditions {see good practice [8-4(1)]}.

2.54 Weighted Sound Reduction Index, R_w — Single number quantity which characterizes the airborne sound insulating properties of a material or building element over a range of frequencies.

NOTE — The weighted sound reduction index is used to characterize the insulation of a material or product that has been measured in a laboratory (see Annex B).

2.55 Weighted Standardized Impact Sound Pressure Level, $L'_{nT,w}$ — Single number quantity used to characterize the Impact sound insulation of floors over a range of frequencies.

NOTE — Weighted standardized impact sound pressure level is used to characterize the insulation of floors in buildings (see Annex B).

2.56 Weighted Standardized Level Difference,

$D_{nT,w}$ — Single-number quantity, which characterizes the airborne sound insulation between rooms

NOTE — Weighted standardized level difference is used to characterize the insulation between rooms in a building (see Annex B).

2.57 Weighted Normalized Impact Sound Pressure Level, $L'_{n,w}$

— Single number quantity used to characterize the impact sound insulation of floors over a range of frequencies.

NOTE — Weighted normalized impact sound pressure level is usually used to characterize the insulation of floors tested in a laboratory (see Annex B).

2.58 White Noise — A noise whose spectrum (level) density is substantially independent of frequency over a specified range and has equal power for any range of frequencies of constant band width.

3 PLANNING AND DESIGN AGAINST OUTDOOR NOISE

3.1 General

Planning against noise should be an integral part of town and country planning proposals, ranging from regional proposals to detailed zoning, and three-dimensional layouts and road design within built-up areas. Noise nuisance should be fully recognized in zoning regulations.

3.1.1 Noise is either generated by traffic (road, air, and surface and underground railway) or it arises from zones and buildings within built-up areas (industry, commerce, offices and public buildings), and from public gatherings and social activities. For planning, the noise survey should examine all the possible causes of noise and consider the various factors causing actual nuisance.

3.1.2 Noise by night, causing disturbance of sleep, is more of a nuisance than noise by day. For this reason, housing colonies that adjoin areas with heavy traffic movement during the night are liable to cause serious complaints. Also, the factories that work by night are liable to cause serious complaints if housing estates adjoin them. While planning, care should be taken that housing colonies are adequately set back from busy airports, state and national highways, factories, main railway lines and marshalling yards.

3.1.3 There are two aspects of defence by planning. The first is to plan so as to keep the noise at a distance. Under this aspect comes the separation of housing from traffic noise by interposing buffer zones, and the protection of schools and hospitals by green belts, public gardens, etc. The second is the principle of shading or screening. This consists of deliberately

interposing a less vulnerable building to screen a more vulnerable one or by providing a solid barrier, such as a wall, between the source and the location to be protected.

3.2 Traffic Noise Levels

3.2.1 For Air Traffic

For guidance, approximate noise levels due to various types of aircrafts, measured on ground, when the aircrafts fly overhead at a height of 450 m, are given in Table 1.

Sl No.	Type of Aircraft	Flyover Noise Levels at 450 m with Take-off Thrust EPN dB
(1)	(2)	(3)
i)	Boeing 737	107
ii)	Boeing 747-200	103
iii)	Airbus A300	101

3.2.2 For Rail Traffic

Noise levels of some typical railway traffic are given in Table 2.

Sl No.	Type of Train	Noise Level at 30 m, Measured on the Side or in the Direction of Train dBA
(1)	(2)	(3)
i)	Steam train, 60 km/h	85
ii)	Diesel train, 60 km/h	83
iii)	Electric train, 60 km/h	77

3.2.3 For Road Traffic

The level of noise generated by road traffic depends upon such factors as the number of vehicles passing per hour, the type of traffic, the preponderance of heavy vehicles, average speed, gradient and smoothness of traffic flow. The smoothness of traffic flow also affects variability of the noise and is governed by such features as roundabouts and traffic lights, and the volume of traffic and pedestrian movement with their effects on stopping, starting, overtaking and honking. The level of traffic noise fluctuates continuously and the way it does, has a considerable effect on the nuisance caused. For assessing traffic noise, noise is measured in dBA. Because of the fluctuating nature of traffic, noise levels due to different volumes of traffic flow with a varying mix of vehicles are given in Table 3.

Table 3 Typical Noise Levels Due to Free-Flowing Road Traffic
(Clause 3.2.3)

Sl No.	Type of Traffic	L_{10} 30 m from Edge of Road dBA
(1)	(2)	(3)
i)	5 000 vehicles per 18 hour day (10 percent heavy vehicles), 50 km/h	65
ii)	10 000 vehicles per 18 hour day (20 percent heavy vehicles), 60 km/h	70
iii)	10 000 vehicles per 18 hour day (40 percent heavy vehicles), 80 km/h	75
iv)	20 000 vehicles per 18 hour day (40 percent heavy vehicles), 80 km/h	77

NOTE — The values are applicable to free flowing traffic without honking.

3.3 Outdoor Noise Regulations

The outdoor noise regulations in force from time to time shall be complied with (see also Annex D).

3.4 Planning and Design

3.4.1 Air Traffic

Near airports two sources of aircraft noise should be considered.

- a) *Flyover noise* — Flyover noise is that which occurs under flight paths close to airports and is the most serious and common problem. As the aircraft passes overhead the noise level at any particular location rises to a peak and then decreases.
- b) *Ground noise* — The noise emitted by an aircraft during ground operations is less variable in direction than flyover noise, but is usually of a longer duration.

3.4.1.1 Aircraft noise may disturb sleep, rest and communication, and as such may be considered potentially harmful to health. It is important that no new development is carried out within areas where the expected noise levels will cause mental and physical fatigue or permanent loss of hearing. In case development in such areas is essential, adequate sound insulation shall be provided for the building.

3.4.1.2 As the problems caused by aircraft noise have become more acute, a number of methods have been devised for evaluating noise exposure in the vicinity of airports. They all combine many factors into a single number evaluation. A commonly used criterion is the noise exposure forecast (NEF). The NEF is used primarily to develop noise contours for areas around airports. It has been accepted generally that noise exposure forecast levels greater than NEF 40 are

unacceptable to people while levels less than NEF 25 are normally acceptable. Levels between NEF 25 and 40 may lead to subjective complaints.

3.4.1.3 While it is theoretically possible to provide sufficient insulation to achieve an acceptable indoor noise environment in the area of very high outdoor noise, there is a level above which aircraft noise seriously affects living conditions no matter how much sound insulation has been applied to the dwelling unit. For this reason it is recommended that no residential development be allowed beyond the NEF 35 level.

3.4.1.4 During summer months, the windows are normally kept open for adequate ventilation. In view of this, no matter how much sound insulation is provided for the building structure, the noise level inside the room can never be less than 10 dB below the outdoor noise level. For very critical buildings, such as buildings necessary for maintaining and supplementing the airport services, and for commercial development, such as hotels, it is possible to provide sealed windows and to centrally air condition the entire building. However, it is not feasible for most of the residential developments in the country. In such cases proper zoning regulations and siting of vulnerable buildings away from aircraft noise are of vital importance.

3.4.2 Rail Traffic

This is a very serious source of noise in built-up areas, both by day and by night. Railway cuttings reduce the spread of noise, whereas embankments extend it. The elevated railway on viaducts or embankment is very common in built-up areas. The elevation increases exposure to noise but in addition the construction of the viaduct may affect the propagation of noise. In this respect solid embankments are preferable to built-up arches, which tend to act as sound boxes. Worst of all are the steel bridges, which greatly magnify the noise due to vibration. Uphill gradients are another feature tending to increase noise, especially of heavy goods trains.

3.4.2.1 Wherever possible, no residential or public building zone should abut onto railway lines, especially on the marshalling yards which is particularly objectionable because of the shrill, clanging and intermittent noise they generate, often at night. The appropriate zones alongside railway lines are industrial and commercial buildings other than office buildings. Where these precautions are not practicable and housing has to abut on to railway lines, every attempt may be made to house as few people as possible in the vicinity of the railway lines.

3.4.2.2 Underground transportation system can be a major cause of disturbance for the neighbouring community. Very high noise levels are propagated to

long distances by the underground high speed railway, as a result of wheel-rail interaction. Both airborne noise and ground or structure-borne vibrations are potential sources of complaints. Noise control measures, therefore, need to be considered for the following:

- a) In stations, where high noise levels are produced at the arrival and departure of trains;
- b) In tunnels, during high speed train movement;
- c) Where an underground rail transit system passes close to existing structures or high rise buildings, adequate attention should also be paid to the problem of ground vibration transmitted to the building, and proper isolation should be provided for critical areas;
- d) Wherever elevated railway tracks are provided, adequate measures should be taken to avoid the spread of noise in the surrounding built up areas; and
- e) In transit cars, where sound insulation is of vital importance to provide comfortable conditions for the commuters.

3.4.3 Road Traffic

3.4.3.1 Convoys of long distance heavy trucks at night moving past through built-up areas cause serious noise complaints. On busy roads, the noise of continuous traffic may be a worse nuisance than that of railways. At least the same precautions may, therefore, be taken in the planning of dwellings in relation to arterial and trunk roads as with railways. Care may be taken that local housing roads do not provide short cuts for heavy traffic through residential areas. Hilly roads present the additional noise of gear changing. Trees with heavy foliage planted on both sides of carriageway help slightly to muffle the noise, provided the foliage extends for a considerable distance (30 m or above).

3.4.3.2 Road traffic may give rise to serious nuisance particularly on busy thoroughfares, between continuous high buildings in main streets, at the traffic lights, near bus stops, on steep slopes and in parking spaces and enclosed yards.

3.4.3.3 For zoning and planning of new buildings in urban areas, it is recommended that external L_{A10} be limited to a maximum of 70 dBA when the dwellings are proposed to have sealed windows and 60 dBA when the dwellings are proposed to have open windows. Indeed it is desirable to confine major new residential development to locations subject to L_{A10} levels substantially lower than those given above.

It is recognized, however, that within the large urban areas, the use of sites where the external L_{A10} is greater than 60-70 dBA cannot always be avoided. In that case it is suggested to utilize such design solutions as barrier

blocks in order to reduce external L_{A10} noise levels to at least 60-70 dBA at any point 1.0 m from any inward looking façade. When the orientation of site and the density of development are such that this cannot be fully achieved some form of dwelling insulation will have to be provided. It should be appreciated that where open windows are necessary, the occupants would have to put up with discomfort if the above conditions are not met.

3.4.3.4 Certain other methods can often be utilized to provide economical and effective protection from noise, as follows:

- a) Methods should be adopted to improve the smoothness of flow and reduce number of stopping and starting. This leads to an improvement even, if it leads to increased flows. Flow linking of traffic lights, for example, may reduce noise nuisance.
- b) Use of roads passing through residential areas should be prohibited to heavy commercial vehicles. An alternative would be to limit use by commercial vehicles to certain times of the day.
- c) Use of honking shall be prohibited near sensitive buildings, such as hospitals and the like.
- d) Barriers shall be provided to shield sites from noise.

3.4.4 Construction Noise

3.4.4.1 Construction activities relating to building and infrastructure facilities cause noise disturbance to occupants in existing built facilities located around the site.

Construction noise involves both stationary and mobile sources. Common activities and sources of concern in case of construction noise include excavation and site clearing activities, blasting, piling, operation of batching plants, concrete mixers, pumping, running of diesel generators, drilling and chipping, loading/unloading activities, and truck and other vehicular movement.

The source noise intensity and spectrum is primarily characterized by the type of construction activity, equipment used, ground conditions and associated vehicular movement. Apart from the source characteristics, community noise impact is influenced by the time and sequence of construction related activities.

3.4.4.2 Noise control can be done at the source or in the noise propagation path. While it is preferable to adopt noise control at the source, it may not be practically possible to implement it for some of the

construction equipment. Given the diversity of noise sources, mitigation strategies in case of construction noise have to be dealt with appropriately depending on the spectral characteristics of sources.

Source noise control strategies include providing acoustic enclosures for sources like diesel generators, choosing less noisy construction machinery and selecting alternative construction practices which involve lesser noise generation.

Noise control in the propagation paths primarily involves provision of noise barriers around the construction sites.

Positioning of major fixed construction equipment/installations such as batching plants and diesel generators have a significant impact on the noise spectrum and its impact. Also, time of operation and duration of noisy construction activities have significant impact on the resultant annoyance.

3.4.4.3 Due consideration for environmental noise regulation should be given while scheduling and sequencing noisy construction activities.

3.5 Zoning

The zoning of the different cities shall be done by the town planning authorities, taking into account besides other aspects, the noise levels from different occupancies. Wherever necessary, experts in the field may be consulted. For detailed information on noise reduction for town planning schemes, reference may be made to good practice [8-4(2)].

3.6 Green Belts and Landscaping

Where relief from noise is to be provided by means of green belts these may be of considerable width and be landscaped. (In case of railway tracks, a minimum distance of 50 m to 70 m may be provided between the buildings and the tracks). The extent of relief that may be derived from the above may be estimated only after considering other environmental factors. Only thick belts of planting (greater than 30 m) are of real value. Strong leafy trees may be planted to act as noise baffles. Shrubs or creepers may also be planted for additional protection between tree trunks; artificial mounds and banks should be formed where practicable. As little hard paving and as much grass as possible may be used. The creation of green belt is particularly advisable on the perimeter of aerodromes, along railway lines and arterial roads, through or past built-up areas and adjoining noisy industrial zones.

3.7 Highway Noise Barriers

Barriers are often the most effective means of reducing traffic noise around residential areas. They have the

great advantage that they generally protect most or all of the site. In nearly all situations, a well-designed barrier of even a modest height (say 3 m) can at least ensure that all areas of open space are free from excessive noise levels.

There are two types of barriers that can be built to protect sites; one which are built solely for the purpose of reducing noise and the other which form part of the building complex (barrier blocks). Free standing walls and artificial mounds are typical examples of the first type while single and multi-storeyed utility buildings and garages are the most common form of the second.

Of the two types, laying out barrier blocks of a complex in an appropriate fashion is a better option because they are cheaper and also tend to form a more effective barrier overall because of their greater height and width. Barrier walls or mounds are more limited in their effect than barrier blocks for they protect little more than the area of the site close to ground level essentially because of the lack of height, as continuous walls much higher than 3 m are often difficult to construct.

3.8 Special Problems Requiring Expert Advice

The purpose of noise control is to ensure that people are neither harmed nor disturbed by noise. In addition to provisions given in this Section, special advice may be required for more complex situations, such as those listed in Annex E.

4 PLANNING AND DESIGN AGAINST INDOOR NOISE

4.1 Acceptable Indoor Noise Levels in Buildings

The generally acceptable noise levels inside buildings are given in Table 4.

Table 4 Acceptable Indoor Noise Levels for Various Buildings
(Clause 4.1)

Sl No. (1)	Location (2)	Noise Level dBA (3)
i)	Auditoria and concert halls	20-25
ii)	Radio and TV studios	20-25
iii)	Cinemas	25-30
iv)	Music rooms	25-30
v)	Hospitals	35-40
vi)	Apartments, hotels and homes	35-40
vii)	Conference rooms, small offices and libraries	35-40
viii)	Court rooms and class rooms	40-45
ix)	Large public offices, banks and stores	45-50
x)	Restaurants	50-55

4.2 Vulnerable Buildings

Some buildings or parts of buildings are especially

vulnerable to noise, for example, recording and radio studios, hospitals and research laboratories. These should not be sited near loud noise sources. Most vulnerable buildings contain some areas which are themselves noisy and in such buildings the less vulnerable elements should be planned to act as noise buffers. Most noisy buildings also contain quiet accommodation, which equally may be planned to act as a buffer between the noisy part of the building and adjoining vulnerable buildings.

4.3 The details of site and internal planning and insulation requirements are covered under individual occupancies (see 5 to 12) as applicable to the respective character and sources of noise in different buildings.

4.3.1 Equitable Inclusion of Hearing Impaired Persons in Public Places

People with hearing impairments have particular difficulty in making out sounds and words in noisy environments. Therefore, adequate sound insulation would minimise noise from both outside and inside the building. Also, low reverberation times are more suitable for hearing impaired persons and should thus be planned while designing the size and shape of the room.

Persons using hearing aids may require quiet areas with induction loops in very noisy information counters or where announcements are made. Induction loops may also be provided in all areas where there are verbal inputs provided, such as conference halls, auditoria, class rooms and cinema halls.

4.4 Sound Insulation of Non-Industrial Buildings by Constructional Measures

The desired (acceptable) noise levels and the recommended insulation values for the various areas may be achieved by providing sound insulation treatments by constructional measures. The details of the same are given in Annex F. The recommendations given in Annex F are applicable to non-industrial buildings like residences, educational buildings, hospitals and office buildings.

4.5 Special Problems Requiring Expert Advice — See 3.8 and Annex E.

5 RESIDENTIAL BUILDINGS

5.1 Sources of Noise Nuisance

5.1.1 Outdoor Noise

The main sources of outdoor noise in residential areas are traffic (aeroplane, railways, roadways), children playing, hawkers, services deliveries, road repairs, blaring loud-speakers, various types of moving machinery in the neighbourhood and building operations, and captive power generation machinery.

5.1.2 Indoor Noise

5.1.2.1 As far as indoor noises are concerned, conversation of the occupants, footsteps, banging of doors, shifting of the furniture, operation of the cistern and water closet, playing of radio, television, music system, cooling and ventilation machinery, etc, contribute most of the noise emanating from an adjacent room or an adjacent building. Noise conditions vary from time to time and noise which may not be objectionable during the day may assume annoying proportions in the silence of the night when quiet conditions are essential.

5.1.2.2 In the case of flats the main sources of noise are from other flats and from stairs, lifts and access balconies. Plumbing noise is another cause. In semi-detached buildings, outdoor noises from streets are noticed more than indoor noises from neighbours.

5.2 Recommendations

5.2.1 Site Planning

The most desirable method is to locate the residential buildings in a quiet area away from the noisy sources like the industrial areas, rail tracks, aerodromes, roads carrying heavy traffic, etc.

5.2.1.1 To minimise ground reflection, the dwellings should be surrounded by the maximum amount of planting and grassed areas and the minimum amount of hard surfacing. This applies particularly to high density areas. Where for maintenance reasons a large amount of hard paving is necessary, it should be broken up by areas of planting and grassing. Narrow hard paved courts should be avoided between adjacent tall buildings.

5.2.1.2 Roads within a residential area should be kept to a minimum both in width and length, and should be designed to discourage speeding. Area-wise planning, with zones from which vehicular traffic is altogether excluded will greatly help to reduce noise. Roads with through traffic should be excluded from residential areas, but where sites have to be developed adjacent to existing major roads the same principles should be observed in the siting of blocks as with railway lines as covered under **3.4.2.1**.

5.2.1.3 Play areas for older children should be sited as far away from dwellings as possible. Special care should be taken with old peoples' dwellings. They should not be placed immediately adjacent to service entries, play spaces, or to any entrances where children may tend to congregate.

5.2.2 Internal Planning

The orientation of buildings in a locality should be

planned in such a way as to reduce the noise disturbance from neighbourhood areas. The non-critical areas, such as corridors, kitchens, bathrooms, elevators and service spaces may be located on the noisy side and the critical areas, such as bedrooms and living space, on the quiet side.

5.2.2.1 Windows and doors

Windows and doors should be kept away from the noisy side of the building as given below, wherever possible:

- a) When windows of a building, particularly those of bedrooms in apartments or flats, face roads carrying heavy traffic or other noises where the external noise is of the order of 80 to 90 dBA, the building should be located at a distance of about 30 m from the road, but a distance of 45 m or more, where possible, should be aimed at for greater relief from noise;
- b) When the windows are at right angles to the direction of the above type of noise, the distance from the road should be arranged to be about 15 to 25 m; and
- c) In case another building, boundary wall or trees and plantations intervene between the road traffic and the house/flat further noise reduction is achieved and in such cases the above distances may be reduced suitably.

5.2.2.2 Layout plans

It is desirable that rooms adjoining party walls and above/below party floors should be of similar use. By this means, bedrooms are not exposed to noise from adjoining living rooms, and there is less risk of disturbance of sleep.

In semi-detached houses, the staircase, hall and kitchen should adjoin each other on each side of the party wall, thus providing a sound baffle between rooms requiring quiet conditions.

Bedrooms should not be planned alongside access balconies, and preferably not underneath them. Where the approach is by an internal corridor, a sound baffle may usefully be provided by arranging internal passages and bathrooms between the corridor and the living room or bedrooms.

Kitchens and water closets should not be planned over living rooms and bedrooms, whether within the same dwelling or over other dwellings. Soil pipes should not be carried in ducts which adjoin living rooms or bedrooms unless the side of the duct next to these rooms is a solid wall containing no inspection openings. Refuse chutes should not be planned next to living rooms or bedrooms.

5.2.3 Sound Insulation

5.2.3.1 Reduction of airborne noise

The weighted sound reduction index, R_w , of partitions between individual rooms or apartments of a building unit shall be as given in Table 5. These values may, however, be suitably increased, where required, for critical areas.

Table 5 Sound Insulation Between Individual Rooms (Airborne)
(Clause 5.2.3.1)

SI No. (1)	Situation (2)	R_w dB (3)
i)	Between the living room in one house or flat and the living room and bed-rooms in another	50
ii)	Elsewhere between houses or flats	45
iii)	Between one room and another in the same house or flat	35

NOTES

1 Where communicating doors are provided, all doors should be so designed as to provide recommended insulation between the rooms.

2 There are cases when a set of houses or flats have to be built for the people who work at night and sleep during the day. It is desirable to consider the design of at least one such room in each of the houses or flats which will provide an insulation of about 45 dB in that room.

3 The insulation values referred to are applicable with doors and windows shut.

5.2.3.2 Suppression of noise at the source itself

All items of equipment that are potentially noisy should be selected with care. Water closet cisterns should not be fixed on partitions next to bedrooms or living rooms. Plumbing pipes should be isolated from the structures. Lift motors should be mounted on resilient supports. Access doors from machine rooms to internal staircases should be well fitting and of solid construction. Special noise control measures may be required for electrical and mechanical services such as diesel generators, outdoor air conditioning units, cooling towers, etc.

5.2.3.3 Reduction of airborne noise transmitted through the structure

Reduction of airborne noise requires the use of rigid and massive walls, or acoustically designed dry walls, without any openings. Openings are the major cause of penetration of noise through a barrier. While designing it should be borne in mind that all components should provide a sound transmission compatible with that of the rest of the barrier so that an equivalent amount of sound energy is transmitted through each portion of the barrier.

Ventilating ducts or air transfer openings where

provided should be designed to minimise transmission of noise. For this purpose, sound attenuating devices having necessary insertion loss may be installed in these openings.

All partitions should be sealed effectively where they butt against rest of the structure. All doors and windows should be properly gasketed where a high degree of sound insulation is desired.

5.2.3.4 Reduction of structure-borne noise

This requires the use of discontinuous or non-homogeneous materials in the construction of the structure.

5.2.3.5 Reduction of impact noise

The floor of a room immediately above the bed room or living room shall result in an impact sound pressure level ($L'_{nt,w}$) not greater than 60 dB. Typically, a 150 mm thick concrete floor with thick carpet (12 mm) covering would satisfy this requirement.

5.2.3.6 Main staircases in blocks of flats are often highly reverberant. Some of the surfaces at least (for example, the soffits of stairs and landings) should be finished with sound absorbent materials, wherever required.

6 EDUCATIONAL BUILDINGS

6.1 Sources of Noise Nuisance

6.1.1 Outdoor Noise

The outdoor sources of noise produced on school premises, which cause disturbance within the school, include the noise arising from playgrounds, playing fields and open-air swimming pools. Though playgrounds are used mainly during break periods, they are also used for games and physical education at times when teaching is in progress in the adjoining class rooms.

6.1.2 Indoor Noise

Indoor sources of noise are as follows:

- Singing, instrumental and reproduced music which may take place in class rooms and in dining and assembly halls particularly in primary schools. In secondary schools, specialized music rooms are generally provided;
- Movement of chairs, desks and tables at the end of one period may disturb a class engaged in a lesson in a room below;
- Shutting and openings of doors and windows which may occur at any time during teaching periods;
- Audio-visual presentations in class rooms;
- Wood and metal workshops, machine shops

- (engineering laboratories), typing rooms, etc, that produce continuous or intermittent sound of considerable loudness;
- f) Practical work carried out in general teaching areas;
- g) Gymnasia and swimming pools;
- h) School kitchens and dining spaces where food preparation and the handling of crockery and utensils persist for the greater part of the school day;
- j) Corridors and other circulation spaces; and
- k) Plumbing and mechanical services.

6.2 Recommendations

6.2.1 Site Planning

Where outdoor noise nuisance exists from local industry, busy roads, railway, airfields, sport grounds or other sources beyond the control of the school authority, school buildings should be sited as far away from the sources of noise, as possible.

6.2.1.1 Rooms should be planned in a manner so that the minimum amount of glazing is placed on the side facing the external noise.

6.2.1.2 Noises arising from the activities of a school and from the use of the buildings after school hours may constitute a nuisance to occupants of surrounding property; therefore, it is desirable to place playgrounds, workshops, swimming pools, music rooms, assembly halls and gymnasia as far away as possible from buildings which require a quiet environment.

6.2.2 Internal Planning

The following principles should be observed in the detailed planning of educational buildings:

- a) *Grouping* — Noisy rooms should be separated from quiet ones, if possible. In general, it is desirable that rooms should be grouped together in accordance with the classification given in **6.2.4.1**.
- b) *Windows and ventilators* — Windows of noisy and quiet rooms should not open on to the same courtyard or be near to one another. Skylights and ventilators over noisy rooms should be avoided, if they are likely to be a source of nuisance to adjacent upper floors.
- c) *Doors* — Swing doors into rooms should only be used where no problem of sound transmission exists. Reduction of insulation between rooms and corridors due to doors shall be borne in mind. The type and method of fitting of doors is important and necessary care shall be paid in this respect.

- d) Sliding partitions, if used, should be acoustic operable partitions. Pass-through doors, if provided, should be acoustic doors with drop seals.

- e) *Open planning and circulation areas* — Where open planning is used to permit spaces, such as assembly halls, dining rooms or entrance halls to be used in association with each other or for circulation, the degree of disturbance caused by interfering noise to teaching areas needs careful consideration; traffic through such areas should be strictly controlled; full use should be made of sound absorbent treatments to reduce the spread of noise from one space to another (*see 6.2.3*).

If rooms have large glazed panels or ventilation openings facing directly on the circulation areas, human traffic passing by the rooms should be controlled. Preferably baffled ventilation system or double windows should be used. Fan-lights over doors should be fixed and glazed.

- f) *Furniture* — In all educational buildings, regardless of the character of the floor finish, rubber buffers should be fitted to the legs of chairs and tables.

6.2.3 Noise Reduction within Rooms

Sound absorbent materials play a useful part in reducing the built-up or airborne noise at source. In rooms, such as classrooms, assembly halls and music rooms, a fairly short reverberation time under occupied conditions is one of the requirements of the acoustic design. The maximum reverberation times permissible for this purpose are usually short enough to give adequate noise control but in addition, the reverberation time should not be excessive under empty conditions, because noise may occur in these rooms with very few occupants. Table 6 gives the reverberation times often arranged in occupied rooms for acoustic reasons and the maximum times recommended in the empty rooms for noise reduction; the times given are for a frequency of 500 Hz, but they should not be greatly exceeded at any frequency. When rooms are used for a variety of purposes, the reverberation period appropriate to the major use should be adopted.

6.2.3.1 Special attention should be given to noise reduction in schools for the hearing impaired and schools for the visually impaired. Hearing impaired children are taught by means of hearing aids which cannot be used satisfactorily in high noise levels or in reverberant conditions. Visually impaired children depend on good hearing for understanding speech and for detecting changes in environment. In both these types of schools, noise levels should be kept low and

reverberation times short. As an example, the reverberation times in empty classrooms should not exceed 1.0 s in schools for the visually impaired or 0.5 s in schools for the hearing impaired.

Table 6 Reverberation Times in Schools

(Clause 6.2.3)

Sl No.	Room	Reverberation Time s	
		Usual for Acoustic Reasons (Full)	Maximum ¹⁾ for Noise Control (Empty)
(1)	(2)	(3)	(4)
i)	Assembly halls	1.0-1.25 according to size	1.5-2.0 according to volume of hall
ii)	Music teaching rooms	0.75-1.25	1.5
iii)	Gymnasias and indoor swimming pools	—	1.5
iv)	Dining rooms	—	1.25
v)	Classrooms	0.6	1.1
vi)	Headmasters room and staff rooms	0.5-1.00	1.0

¹⁾ Shorter reverberation times are desirable for noise control, whenever possible.

6.2.4 Sound Insulation

6.2.4.1 Airborne noise

For purposes of sound insulation, rooms in educational buildings may be classified as follows:

Class A	Noise producing	a) Workshops b) Kitchens c) Dining rooms d) Gymnasiums e) Indoor swimming pools
Class B	Noise producing but needing quiet at times	a) Assembly halls b) Lecture halls c) Music rooms d) Typing rooms
Class C	Average	a) General class-rooms b) Practical rooms c) Laboratories d) Offices
Class D	Rooms needing quiet	a) Libraries b) Studies
Class E	Rooms needing privacy	a) Medical rooms b) Staff rooms

6.2.4.2 The recommended minimum sound reduction (D_w) between rooms of the same class is as follows:

- a) Class A : 25 dB
- b) Class C or D : 35 dB
- c) Class B or E : 45 dB

6.2.4.3 Where a room is likely to have a dual use, for example, a dining room to be used as a classroom, the higher sound insulation value should be used.

6.2.4.4 The recommended minimum sound reduction (D_w) between rooms in different classes is 45 dB subject to the following:

- a) In schools or institutes with a technical bias where noisy activities, such as sheet metal work, plumbing and woodwork, are likely to be practised extensively in normal hours, workshops should be regarded as a special category requiring more than 45 dB isolation (D_w) from rooms of any other class.
- b) Assembly halls and music rooms are special cases in that, as well as producing noise, they also require protection from it and may need more than 45 dB isolation (D_w) from rooms in Class A, if the latter are very noisy.
- c) Circulation spaces may vary from a long and frequented corridor to a small private lobby and it is therefore difficult to give precise recommendations to cover them. For partitions between rooms in Class C and most corridors, an R_w of 35 dB for the partition itself is adequate. For partitions between rooms in other classes and corridors, more or less insulation may be necessary, depending upon the specific usage.
- d) The problem of noise in circulation areas is as a rule greatly mitigated in schools by the fact that classes usually change rooms together at regular times. In colleges and evening institutes, however, this is much less true and in such buildings particular attention should be paid to insulation between rooms and corridors.

6.2.4.5 Impact noise

In the case of schools, the concrete floor of the room immediately above the teaching rooms shall provide an impact sound pressure level, $L'_{nT,w}$ not greater than 70 dB. For example, a covering of 6 mm linoleum or cork tiles on concrete floor (hollow or solid) weighing not less than 220 kg/m² will usually meet the above requirement.

7 HOSPITAL BUILDINGS

7.1 General

Problems of noise control vary from hospital to hospital but the principles outlined below apply to all types. A quiet environment in hospitals is desirable for patients who are acutely ill. Staffs require quiet conditions for consultations and examinations and also in their living and sleeping quarters. There have been rapid rises in noise levels in hospitals due to the higher levels of outdoor noise, increasing use of mechanical and mobile equipment (some of which is now brought much nearer to the patient in order to facilitate nursing procedure) and the introduction of loudspeaker, radio, television and call systems. Noise control in the hospital is made much more difficult by the extensive use of hard washable surfaces which reflect and intensify the noise. In most hospitals, windows to the open air and fanlights to corridors are usually open for the purpose of ventilation, admitting noise from outside and allowing it to spread through the building.

7.2 Sources of Noise Nuisance

7.2.1 Outdoor Noise

This may be classified into two main categories:

- a) Noise from sources outside the hospital premises, for example, traffic and industrial noises; and
- b) Noise from sources outside the building but usually within the control of the hospital authority, for example, ambulances, motor-cars and service vehicles, fuel and stores deliveries, laundries, refuse collection, trucks and trolleys.

7.2.2 Indoor Noise

A hospital is a complex building with many services and the numerous internal sources of structure-borne and airborne noises are grouped into three main categories:

- a) Noise consequent upon hospital routines. This category includes sources which transmit noise through both structure-borne and airborne paths, many of which may be quite near to patients particularly those in wards, such as the following:
 - 1) Wheeled trolleys of various kinds, for food and medical supplies;
 - 2) Sterilizing equipment;
 - 3) Sluice room equipment including bedpan washers;
 - 4) Ward kitchen equipment;
 - 5) Footsteps;

- 6) Doors banging;
 - 7) Handling of metal or glass equipment;
 - 8) Noises caused during maintenance and overhaul of engineering services; and
 - 9) Vacuum cleaners, mechanical polishers, etc.
- b) Loudspeaker, radio or television, audible call system, telephone bells and buzzers, and other airborne noises, such as loud conversation; and
 - c) Noises from fixed or mobile equipment and services not directly concerned with hospital routines. These include all the fixed services as given below:
 - 1) Plumbing and sanitary fittings;
 - 2) Steam hot and cold water and central heating pipes;
 - 3) Ventilation shafts and ducts;
 - 4) Fans
 - 5) Boilers;
 - 6) Pumps;
 - 7) Air compressors;
 - 8) Pneumatic tubes;
 - 9) Electrical and mechanical motors and equipment;
 - 10) Lifts;
 - 11) Laundry equipment; and
 - 12) Main kitchen equipment (refrigerators, mixers, steam boilers, etc).

7.3 Recommendations

7.3.1 Site Planning

Hospital sites with their high degree of sensitivity to outside noise should be as far away from outside sources as may be compatible with other considerations, such as accessibility and availability of services. The building should be so arranged on the site that sensitive areas like wards, consulting and treatment rooms, operating theatres and staff bedrooms are placed away from outdoor sources of noise, if possible, with their windows overlooking areas of acoustic shadow.

7.3.2 Detailed Planning

There is a very large number of unit and room classification in hospital design and in planning the units in relation to each other and to the common services, (such as X-ray departments, operating theatre suits and main kitchens), noise reduction in the sensitive areas should be weighed carefully against other design factors. Special care in overall planning and internal planning against noise is required in the planning within the building of units which are themselves potential noise sources, for example, children's wards and

outpatients' departments, parts of which require protection against noise.

7.3.2.1 Unloading bays, refuse disposal areas, boiler houses, workshops and laundries are examples of service units which should be as far from sensitive areas as possible.

7.3.2.2 The kitchen is a constant source of both airborne and structure-borne noise and should preferably be in a separate building away from or screened from the sensitive areas. If this is not possible and the main kitchens shall form part of a multi-storeyed building, noise control is easier if they are placed below and not above the wards and other sensitive rooms so as to facilitate the insulation of the equipment and machinery in order to reduce the transmission of structure-borne noise to a minimum.

7.3.2.3 In ward units, the kitchens, sluice rooms, utility rooms, sterilizing rooms and other ancillary rooms, need to be placed quite near to the beds if they are to fulfil their purposes, which are all sources of noise. Some form of noise baffling between open wards and rooms of this kind will be needed.

7.3.3 Reduction of Noise at Source

In view of the difficulty of suppressing noise in hospital buildings, it is important to eliminate noise at its source, wherever possible.

7.3.3.1 Use of resilient material

Mats of rubber or other resilient material on draining boards and rubber-shod equipment will greatly reduce noise from utility rooms, sluice rooms and ward kitchens. The use of plastics or other resilient materials for sinks, draining boards, utensils and bowls would also reduce the noise. Many items of equipment especially mobile equipment, such as trolleys, beds and movable furniture, may be silenced by means of rubber-tyred wheels and rubber bumper and the provision of resilient floor finishes (*see 7.3.4.1*). The latter also reduces footstep noise. Silent type curtain rails, rings and runners should be used. Lift gates and doors should be fitted with buffers and silent closing gear. Fans and other machinery should be mounted on suitable resilient mountings to prevent the spread of noise through the structure.

7.3.3.2 Other measures

Noise from water or heating pipes may be reduced by installing systems which operate at comparatively low pressure and velocities. Silencing pipes and specially designed flushing action reduce water closet noise at source and make structural measures easier to apply. The ventilation system should be designed so as not to create a noise problem. Silent closers should be fitted to doors.

7.3.4 Reduction of Noise by Structural Means

7.3.4.1 Insulation

Since the various departments or units may be planned in many ways, only general guidance on the insulation values for walls and partitions is as given below:

- a) It is recommended that walls or partitions between rooms should normally have an R_w of at least 45 dB. Higher values of R_w of at least 50 dB are necessary where a noisy room is adjacent to one requiring quiet conditions. Doors should be solid with close fitting in the frames.
- b) There is little insulation value in double swing doors and where these are fitted to a noisy room the opening should be planned so that it is screened from areas requiring quiet by a baffle lobby lined with absorbent material. Very high insulation values may be necessary in special cases and exceptional measures may be required.
- c) Solid floors with floating finishes and resilient surfaces are necessary particularly between wards and other parts of the building. Ordinary timber board on joist floors should never be used.
- d) Conduits, ventilation ducts, chases, etc, should be constructed so as not to form easy by-pass for disseminating noise about the building, and should be provided with sufficient sound insulation. Pipe ducts should be completely sealed around the pipes where they pass through walls or floors. Ducts carrying waste or water pipes should be lined with sound insulating material to prevent noise from the pipes passing through duct walls into the rooms through which they pass.

7.3.4.2 Absorption

Most surfaces in hospitals should be easily cleanable, so as to prevent the build-up of bacteria which may cause cross-infection. Many sound absorbent materials of a soft nature and difficult to clean are unsuitable for use in some hospital areas and lose much of their effectiveness, if painted for hygienic reasons.

Some porous materials with very thin non-porous coverings (like mineral wool covered with thin plastic sheets) have good sound absorption and when covered with a perforated sheet metal facing can be used in most areas requiring a washable acoustical treatment. In noisy areas, such as corridors and waiting rooms, however, a wider choice of absorbents is available.

In the ward, bed curtains, window curtain, etc, add to the absorbent properties of the room and help reduce

reverberation in otherwise hard surfaced surroundings.

7.3.5 Sensitive areas such as operation theatres, doctors' consultation rooms, intensive care units (ICU) require special consideration against noise control. Apart from outdoor noise, a common problem is the transmission of sound between the consulting room and the waiting room. To ensure silence, a sound isolation D_w of 45 dBA, between the rooms shall be provided. If the doors are directly connected by a single communicating door it will not be possible to achieve these values of isolation D_w . To obtain 40-45 dBA insulation between communicating rooms, it is necessary to provide two doors separated by an air gap, such as a lobby or corridor.

8 OFFICE BUILDINGS

8.1 General

Modern office buildings are often noisier than older buildings due to the use of thinner and more rigid forms of construction, harder finishes, more austere furnishings and use of business machines.

8.2 Sources of Noise Nuisance

8.2.1 Indoor Noise

Main sources of indoor noise include the following:

- a) Office machines, such as keyboards, typewriters, and printers;
- b) Telephonic conversation;
- c) Noise from the public admitted to the building;
- d) Footsteps, voices and slamming of doors in circulation spaces, lift doors and gates;
- e) Sound reproduction in staff training rooms, conference rooms and recreation rooms, etc;
- f) Handling of crockery and utensils in canteens and kitchens; and
- g) HVAC and lift machinery.

8.3 Recommendations

8.3.1 Site Planning

Rooms demanding quiet conditions should be placed on the quiet side of the site. Even on quiet thoroughfares, these rooms should also not be planned at street level. They should also not be planned on enclosed yards used for parking of cars, scooters, etc. Where, however, the problems cannot be resolved by planning, the provision of double windows may be necessary.

8.3.2 Detailed Planning

8.3.2.1 Noise reduction within rooms

The reverberation time should not exceed 1.0 s in all

general offices of the types listed in **8.3.2.2** to **8.3.2.6**. In small private offices, the reverberation time should not exceed 0.75 s, in very large offices the reverberation time may be increased to 1.0 s. For canteens, the recommended maximum reverberation time is 1.0 s.

NOTE — All reverberation times are specified for a frequency of 500 Hz.

8.3.2.2 Large general offices

The grouping of departments and machines together in one room should be avoided, wherever possible. Where supervision is necessary the provision of glazed screens carried up to the ceiling should be considered. If it is essential to the work of an office for machine operators and clerks to work side by side in the same room, the machines should be enclosed by panels or low screens lined with absorbent material and the ceiling should be sound absorbent. In addition, the machines should be as quiet as possible in operation and mounted on suitable resilient mountings.

NOTE — A quiet area should be planned for prolonged telephonic conversation.

8.3.2.3 Light weight construction

Modern construction methods and economy dictate the use of light weight construction for many office buildings. While the lightweight materials lead to fast fabrication and erection and also effect considerable economy in the building structure, they may lead to tremendous sound insulation problems between adjacent offices and areas. Light weight construction is also frequently employed for the subdivision of large space into executive cabins and secretarial areas. Where such construction is considered desirable, efforts should be made to provide a double-skin panel. The panels should be isolated from each other as far as possible either by the use of separate framing or by the use of elastic discontinuities in the construction, and a sound absorbing material may be introduced in the air cavity between the panel. The partitions should be of full height up to the bottom of the roof above and any openings required for air movement should be provided with sound attenuators compatible with the rest of the partition.

When light weight floors are provided in multi-use buildings, adequate attention shall be paid to the question of airborne and structure-borne noise transmission from the upper floors to the floors below. For effective reduction of airborne noise, a double panel hollow floor construction may be employed with some heavy sound damping material introduced between the panels and the panel isolated from each other. The sound damping material could be sand, mineral wool, etc. In case impact noise isolation is also required, the upper panel should be effectively isolated from the rest

of the floors and building structure. The choice of the isolation layer would of course depend upon the lowest frequency of interest.

Another point to be kept in mind when going in for light weight construction is to ensure that the light weight panels are not in resonance with the natural frequencies of any mechanical equipment installed inside the building. Light weight materials have high natural frequencies well within the audio range and may resonate or vibrate due to an applied vibratory force. This vibratory force is caused by mechanical equipment, road traffic, rail traffic, etc. Special measures also need to be taken to isolate either the source or the building so as to reduce the amount of vibration transmitted to the building structure.

8.3.2.4 Open plan offices

A new concept in office planning is the use of open plan offices. Large open floor spaces are converted into an office area with senior executives, junior executives and secretarial staff all seated within the same area without the use of any partitions or walls. While this method of planning is appreciated, it leads to a problem of inadequate acoustical privacy between adjacent work spaces. Speech privacy in open plan offices is defined by the speech interference level of intruding noise. Speech privacy between two adjacent rooms or spaces is, therefore, a function of two key parameters; noise reduction of the intervening partition and background noise levels.

Special design measures are, therefore, required to reduce the level of intruding sounds at work places to acceptable low value so that people are not disturbed and adequate privacy is maintained. Some special measures which might be considered for such open plan offices are the use of an acoustical ceiling together with partial height barriers between work spaces, all designed to provide adequate privacy between adjacent work spaces. In addition use may have to be made of an electronic background masking noise system which provides a constant level of a generally acceptable background noise in the entire office area. The masking noise system is a very useful concept in open plan office design because by raising the background level at every workplace, intruding noises are made less disturbing. A background music system cannot serve as a noise masking system because the music does not have a constant spectrum or sound level. In fact the background noise masking system shall be introduced gradually without the knowledge of employees. The air-conditioning system can also be used to generate background masking noise, if the noise level from the fans, ducts and grills is suitably tailored to generate the desired frequency spectrum. However, it is not simple to predict the noise level of air conditioning

components accurately. On the other hand, the electronic system enables both the level and the spectrum of the background noise to be accurately adjusted to suit individual job requirements.

8.3.2.5 Office equipment rooms

It is important that machines like keyboards, typewriters, printer, etc, should be quiet in themselves and also be fitted with resilient pads, to prevent the floors or tables on which they stand from acting as large radiating panels. It is desirable to locate machines further apart and to apply sound absorbent treatment to the ceiling.

8.3.2.6 Banking halls

If banking halls are large and lofty, noise nuisance tends to be aggravated. It is advisable to avoid high reflective ceilings. The worst effects may be reduced by segregating the noise from the quiet operations and screening one from the other and by applying sound absorbent materials to the surfaces of the ceilings, screens and nearby walls. Resilient flooring is also recommended.

8.3.2.7 Public offices and waiting spaces

Noise nuisance may be minimised by the provision of resilient flooring, sound absorbent ceilings and heavy full height screens between the public space and the clerical office.

8.3.2.8 Canteens

The provision of a sound absorbent ceiling, resilient flooring and the use of plastics trays and tables with quiet tops are recommended.

8.3.2.9 Circulation spaces

The effective length of long corridors should be limited by providing swing doors at intervals. Hard floor finishes and board and batten floors in corridors should be avoided. The provision of a sound absorbent ceiling in corridors is recommended. Floor ducts should be planned on one side of corridors.

The noise from slamming of doors may be reduced by fitting automatic quiet action type door closers. Door buffers are useful but may reduce insulation of airborne sound due to the inevitable gaps between buffers. Continuous soft, resilient strip let into the door frames is preferable. The use of quiet action door latches is recommended.

Staircases and lifts should be isolated from quiet rooms and should have silent type doors.

8.3.3 Requirement of Sound Insulation

With open window (single or double) the sound reduction (D_w) will be 5-10dB, and with sealed double

windows it will be 40–45 dB. Intermediate values are obtainable with closed openable windows (single or double) but only, of course, at such times as ventilation may be dispensed with. Having to choose between ventilation and noise exclusion is a serious handicap to efficient working in offices. In large office blocks on noisy sites, consideration should be given to the provision of sealed double windows and mechanical ventilation at least in the offices on the sides of the building exposed to noise.

8.3.3.1 The insulation necessary between adjoining rooms, both horizontally and vertically, depends upon the amount of noise created within the rooms, the amount of intruding noise and whether it is important that conversation should not be overheard between rooms. Generally a sound isolation value (D_w) of 40 dB between one room and another room in office is recommended.

8.3.3.2 The following list may be considered as broad classification of noise producing rooms and rooms requiring quiet though many offices fall into both categories. Where rooms in opposing categories are planned adjacent to each other, a sound reduction (D_w) of at least 45 dB should be provided between them.

<i>Sl No.</i>	<i>Noise Producing Rooms</i>	
i)	Entrance and reception halls, staircases and corridors used by the public	
ii)	Lifts and lift halls	
iii)	Motor and plant rooms	
iv)	Lavatories	
v)	Public offices	
vi)	Canteen and kitchens	
vii)	Office machine rooms and typing pools	
viii)	Recreation rooms	
ix)	Large general offices	
x)	Cinemas and projection rooms:	
<i>Sl No.</i>	<i>Rooms Requiring Quiet Conditions</i>	
i)	Executive's rooms, Conference rooms and board rooms	
ii)	Interview rooms	
iii)	Offices for one or two persons	
iv)	Medical officer's rooms	
v)	Sick rooms	
vi)	Rest rooms	
vii)	Libraries	
viii)	Telephoning rooms	
		D_w
a)	Rooms requiring quiet (as listed above) on a quiet site where privacy is required	45 dB

- b) Rooms requiring quiet (as listed above) but on a noisy site or where a lower degree of privacy is tolerable 40 dB
- c) Clerical offices in which noise does not constitute a major nuisance 30 dB

8.3.3.3 It is recommended that the minimum sound reduction index, R_w for floors should be 45 dB, and the floors should have a resilient finish.

9 HOTELS AND HOSTELS

9.1 General

Hotels and hostels are primarily used as dwelling units, and hotels also provide for public entertainment. The most serious risk, of course, is disturbance to sleep, and adequate care therefore needs to be taken to protect the occupants from being disturbed by outdoor and indoor noise.

9.1.1 Outdoor Noise

Hotels near railway stations, airports, highways and those situated in highly urbanized areas are especially vulnerable to outdoor noise. The outdoor noise in many of the areas is of a high level even late at night and early in the morning. The noise could also be due to other types of activities such as building construction (pile driving, concrete mixing, etc) and due to various types of portable utility equipment, such as compressors or generators.

9.1.2 Indoor Noise

Insofar as indoor noise is concerned, the noise could be due to the occupants themselves, which is transmitted from one room to the other. It could also be due to public functions and late night use of restaurants located in the hotel, as also due to miscellaneous utility equipment installed for providing and maintaining the services in the hotel, such as air conditioning equipment, pumping equipment, power laundry and kitchen. Sometimes hotels equipped with standby generators are a potential source of noise. Another source which could lead to disturbance to the occupants is the plumbing system.

9.2 Recommendations

9.2.1 Site Planning

While it is desirable to locate the hotel, or hostel away from an area where there is a high ambient noise level, many a time these have to be located in noisy areas for public convenience. Hotels near airports and railway stations are becoming popular because they are convenient for passengers in transit. Hotels located in the commercial areas of a city are also a commercially

viable proposition and many a time this factor outweighs the other problems associated with such a location. When a reasonably quiet location is not possible, it is desirable that adequate measures be considered to provide a comfortable acoustical environment for the occupants.

9.2.2 Internal Planning

Where a hotel is located in a noisy environment, the provision of sealed windows (single or double) and provision of an air conditioning system is desirable for rooms exposed to noise. The requirements for the windows would of course depend upon the level and character of noise in the area.

The general recommendations for satisfactory acoustical design of hotels and hostels are given in 9.2.2.1 to 9.2.2.7.

9.2.2.1 Hotels of all classes shall by necessity provide good protection against indoor noise. Since hotels can be considered as flats, the standards of protection recommended for flats are also applicable to hotels. Partition between guest rooms and between rooms, corridors and floors shall not be less than 230 mm brick wall plastered or equivalent ($R_w = 50$ dB). The floors shall have proper impact insulation. Special attention should be paid to built-in wall cupboards as these are potential areas of sound leakage. These will not serve as sound insulating partitions and may not be relied upon to increase the insulation value of partitions against which they may be built. In fact, partitions between adjoining rooms should be continuous behind the cupboards. Use of silent type door gear and cupboard catches is also highly desirable.

9.2.2.2 Door openings on opposite sides of corridors shall be staggered and doors shall be provided with gaskets on head, sides and threshold. Inter-communicating doors should be double doors, fully gasketed. Doors should also have quiet action latches. Whenever possible, rooms should be entered through a baffle lobby. Wherever possible, corridor walls should not have ventilators unless they are double glazed and non-openable.

9.2.2.3 Corridors and staircases may have resilient floor coverings and sound absorbent ceilings are desirable unless the corridor is fully carpeted. Staircases and lift wells may be cut off from corridors by means of swing doors and, if possible, isolated from guest rooms by linen stores or similar rooms. Room service pantries on floors can also be a source of noise and may be separated from corridors by baffle lobbies, unless the rooms themselves have baffle lobbies.

9.2.2.4 Except within the same suite, bathrooms should not be planned next to bedrooms. Where this is unavoidable, internal pipe shafts with heavy walls,

unpierced on bedrooms side may be used as means of separation. It is important to choose quiet type of sanitary fittings and to design the plumbing system so as not to create noise by avoiding sharp bends, restrictions of flow, quick-action valves that might cause water hammer, etc.

9.2.2.5 Air conditioning system should be quiet in operation. Care should also be taken that the air-conditioning ducts do not lead to a cross-talk problem between rooms. Suitable acoustical lining should be provided in the ducts consistent with the fire safety requirements of the buildings.

9.2.2.6 Large hotels often have banquet halls and conference halls which are separately hired out for public and private functions. Late night restaurants and night clubs are also popular and functions in all these areas may go on well into the night. It is therefore essential that these rooms be effectively isolated from bedrooms and effective insulation from all possible noise sources is considered. Here it is not only necessary to consider the airborne sound insulation but it is also necessary to consider the question of structure-borne and impact noise transmitted from areas where there might be dancing late into the night. Floating floors may be considered for structure-borne sound isolation for dance floors and loudspeakers.

9.2.2.7 While most of the noise problems encountered in hotels are applicable to hostels, the latter are normally of more economical construction and, therefore, do not cater for special sound insulation provisions. However, as far as possible, precautions should be taken to provide comfortable conditions in hostel rooms. This is especially true for student hostels where each room is also a living room. Students might play music or have loud discussions late into the night.

This may disturb sleep or study of other students. Proper precautions should, therefore, be taken to provide satisfactory conditions.

10 INDUSTRIAL BUILDINGS

10.1 General

Industrial buildings are primarily producers rather than receivers of noise. The level of industrial noise commonly exceeds that from any other source with the exception of aircraft. As compared with traffic noise, its effects are less widespread but it is often more annoying in character.

10.1.1 Many industrial noises contain very strong high frequency whines, screeches and clatter-these components are relatively more attenuated by passage through the air and by the insulation of light structure than are noises of lower frequencies.

10.1.2 Intermittent noises are either isolated explosions or reports, or noises of a periodic nature, such as those of pressure relief valves of blow off, or the noises of work occurring at random intervals, for example, hammering, grinding and sawing operations; the latter class may be especially irritating because of high frequency components.

10.2 Sources of Industrial Noise

10.2.1 Noises in industrial buildings are mainly of indoor origin. Noise in factories and workshops is generally caused by machine tools and by operations involved in making and handling the product and they are classified into the following groups, depending on how the noise energy is generated.

10.2.1.1 Impact

Noise caused by impact is the most intense and widespread of all industrial noises. It is normally coupled with resonant response of the structural members connected to the impacting surface. Common sources of this type of noise are forging, riveting, chipping, pressing, tumbling, cutting, weaving, etc. Intense impact noise may also be produced during handling of materials as in the case of sheared steel plates falling one over another in collecting trays in a steel factory. Impact noise is usually intermittent and impulsive in character, but it may also be continuous as in the case of tumbling.

10.2.1.2 Friction

Most of the noise due to friction is produced in such processes as sawing, grinding and sanding. Friction also occurs at the cutting edge on lathes and other machine tools and in brakes and from bearings. The spectrum of frictional noise often predominates in high frequency and is very unpleasant in character.

10.2.1.3 Rotation and reciprocation

A rotating or reciprocating machine generates noise due to unbalanced forces and/or pressure fluctuations in the fluids inside the machines. In many cases, the moving surfaces radiate noise directly and in other cases, the pressure fluctuations are transmitted to the outer casings of the machine from where they are radiated as noise. Interaction of rotating component with the fluid stream can also give rise to pure tone components, such as the whine in a turbine. Since most machine casings have radiation efficiencies of unity in the higher frequency range, the amount of sound radiated is often substantial.

10.2.1.4 Air turbulence

Noise may be generated by rapid variation in air pressure caused by turbulence from high velocity air, steam or gases. Common examples are the exhaust noise from pneumatic tools and air jets. The noise is intense,

and broad based in character and the frequency criteria depends on the size of the jet. The intensity increases rapidly with the velocity of the air stream.

10.2.1.5 Noises with pure tone components

Whining noise from turbines and humming noise from transformers come under this group.

10.3 Noise Criteria

10.3.1 Hearing Damage — Risk Criteria

Continuous exposure to high noise levels may result in permanent noise induced hearing loss in the course of time. Damage-risk criteria specify the maximum levels and duration of noise exposure that may be considered safe. Generally accepted damage-risk criteria for exposure to continuous, steady broad band noise are shown in Table 7. Whenever the sound levels at the workers position in a factory exceed the levels and the duration suggested, feasible engineering controls shall be utilized to reduce the sound to the limits shown. If such controls fail to reduce sound levels within the levels of Table 7, personal hearing protection equipment shall be provided and used to reduce sound levels within the level shown.

10.3.2 Interference with Communication

In factories where audible warning signals are used, or where an operator follows the operation of his machine by ear, the background noise should not be so loud as to mask the signal or desired sound (the information sound) to be heard. Noise may be the cause of accidents by hindering communication or by masking warning signals.

10.4 Methods of Reducing Noise

10.4.1 Noise Control by Location

Machines, processes and work areas which are approximately equally noisy should be located together as far as possible. Areas that are particularly noisy should be segregated from quiet areas by buffer zones that produce and may tolerate intermediate noise levels.

10.4.2 Noise Reduction by Layout

The office space in a factory should as far as possible be located preferably in a separate building. This building should not have a wall common with the production area. Where a common wall is unavoidable, it should be heavy with few connecting doors and no permanent openings.

10.4.3 Noise Reduction at Source

10.4.3.1 Selection of machinery

Noise should be reduced as near the source as possible. While the operational processes in a factory may be

Table 7 Permissible Exposure Limits for Steady-State Noise
(Clause 10.3.1)

Sl No.	Sound Level (Slow Response) dBA	Time Permitted, T h : min
(1)	(2)	(3)
i)	85	16:00
ii)	86	13:56
iii)	87	12:08
iv)	88	10:34
v)	89	9:11
vi)	90	8:00
vii)	91	6:58
viii)	92	6:04
ix)	93	5:17
x)	94	4:36
xi)	95	4:00
xii)	96	3:29
xiii)	97	3:02
xiv)	98	2:50
xv)	99	2:15
xvi)	100	2:00
xvii)	101	1:44
xviii)	102	1:31
xix)	103	1:19
xx)	104	1:09
xxi)	105	1:00
xxii)	106	0:52
xxiii)	107	0:46
xxiv)	108	0:40
xxv)	109	0:34
xxvi)	110	0:30
xxvii)	111	0:26
xxviii)	112	0:23
xxix)	113	0:20
xxx)	114	0:17
xxxi)	115	0:15

NOTES

1 Where the table does not reflect the actual exposure times and levels, the permissible exposure to continuous noise at a single level shall not exceed the time *T* (in h) computed from the formula:

$$T = \frac{16}{2^{[0.2(L-85)]}}$$

where

L = work place sound level measured in dBA.

2 When the daily noise exposure is composed of two or more periods of different levels, their combined effect should be considered rather than the individual effect of each. The combined levels may not exceed a daily noise dose, *D* of unity where *D* is computed from the formula:

$$D = \frac{C_1}{T_1} + \frac{C_2}{T_2} + \dots + \frac{C_n}{T_n}$$

where, *C*₁, *C*₂ *C*_{*n*} indicate the total duration of exposure (in hour) at a given steady-state noise level; and *T*₁, *T*₂, ..., *T*_{*n*} are the noise exposure limits (in hour for the respective levels given in the table or computed by the equation in Note 1. Exposure to continuous noise shall not exceed 115 dBA regardless of any value computed by the formula for the daily noise dose, *D* or by the equation in Note 2.

fixed and may have no quieter alternative, careful selection of the machine tools and equipment to be used may considerably help attaining lower noise levels in the machine shop.

10.4.3.2 Reducing noise from potential sources

Impact that is not essential to a process should be quietened. Noise from handling and dropping of materials on hard surface may be reduced by using soft resilient materials on containers, fixing rubber tyres on trucks, trolleys, etc. Machine noise may be kept to a minimum by proper maintenance. Proper lubrication reduces noise by friction conveyors, rollers, etc.

10.4.3.3 The noise from the radiating surfaces may be reduced by reducing the radiating area. For example, if the area is halved, the noise intensity will be reduced by 3 dB and at low frequencies the reduction will be much greater.

10.4.3.4 Supporting structures for vibrating machines and other equipment should be frames rather than cabinets or sheeted enclosures. If an enclosure is used, precaution should be taken to isolate it and line it on the inside with sound-absorbent material. Penetration through the enclosure should be adequately sealed. The noise radiated by machinery guards can be minimised by making them of perforated sheet or of wire mesh.

10.4.3.5 Reducing transmission of mechanical vibration

A vibrating source does not usually contain a large radiating surface but the vibration is conducted along mechanically rigid paths to surfaces that can act as effective radiator. If the rigid connecting paths are interrupted by resilient materials, the transmission of vibration and consequently the noise radiated may be greatly reduced. The reduction depends on the ratio of the driving (forcing) frequency of the source to the natural frequency of the resilient system. The natural frequency may be determined from static deflection under actual load as given in Fig. 1. The higher the ratio between the two frequencies, the lesser is the transmissibility, which is defined as the ratio of the force transmitted through the resilient isolator to the exciting force applied to it. Transmissibility and the equivalent noise reduction for various frequency ratios are given in Fig. 2. For satisfactory operation, a ratio of 3 : 1 or more between the driving and natural frequencies is recommended.

Materials for isolators and their position are given below:

- a) *Material for isolators* — Vibration isolators are usually made of resilient materials like steel in the form of springs and rubber.
 - 1) Because of the large range of deflections

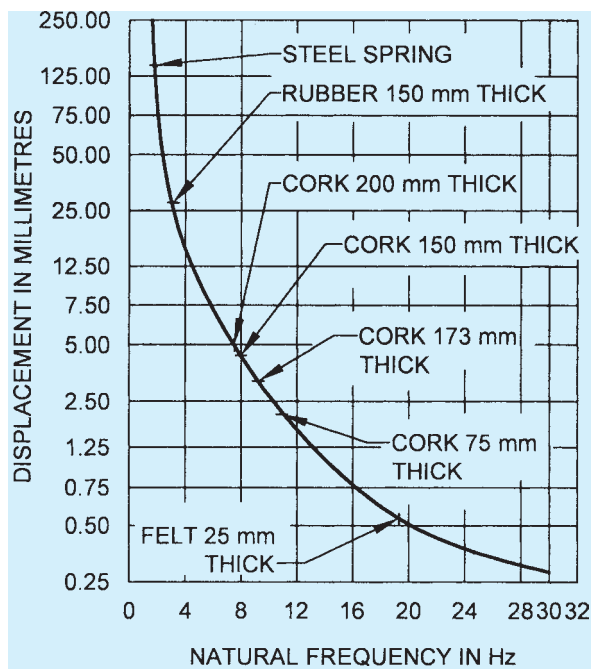

FIG.1 RELATION BETWEEN STATIC DEFLECTION AND NATURAL FREQUENCY

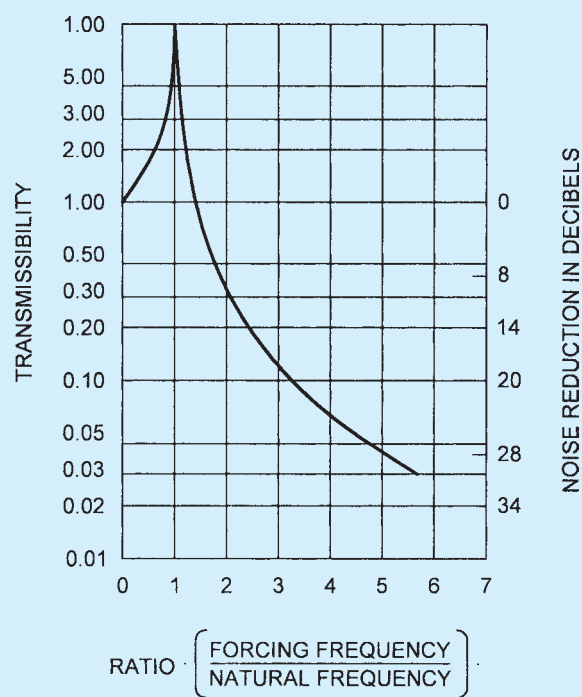

FIG. 2 TRANSMISSIBILITY AND EQUIVALENT NOISE REDUCTION FOR DIFFERENT RATIOS OF FORCING AND NATURAL FREQUENCIES

obtainable in coil springs, they may isolate vibrations over a large spectrum of low frequencies. Metal springs transmit high frequency (from about two hundred

to several thousand c/s) very readily. Transmission of these frequencies can be reduced by eliminating direct contact between the spring and the supporting structure. Rubber or felt pads may be inserted between the ends of the spring and the surfaces to which it is fastened.

- 2) Rubber in the form of pads may be used to very effectively isolate engines, motors, etc. It may be used in compression or in shear. Some rubber mountings use rubber-in-shear as the primary elastic elements and rubber-in-compression as a secondary element which furnishes snubbing action if the mounting is subjected to an overload.
- 3) Felt or cork or both may be used as resilient mats or pads under machine bases. The load per unit area shall be chosen to produce enough deflection for the isolation required; and shall be such that at this deflection, it is not loaded beyond its elastic limit.

b) *Position of isolators* — The normal position of the isolators is between the machine and its foundation. However, if the forcing frequency of the machine is low (less than 10 Hz) and vibration isolators with the requisite deflection for this location are not available, the machine may be bolted directly to an independent heavy inertia concrete base and the available vibration isolators used below the concrete base.

- 1) Large press and drop hammers which create serious impact vibration in heavy machine shops may be mounted rigidly on very massive blocks of concrete having weights several times greater than the weights of the supported machines. The inertia blocks may, in turn, be isolated from the building structure by large wooden blocks and with thick pads of cork.
- 2) In critical installations (*see Note*), attempt should be made to locate the resilient mounts in a plane which contains the centre of gravity of the mounted assembly. It is also preferable to locate the mounts laterally as far away as possible from the centre of the machine.

NOTE — Critical installations are those installations where transmission of vibration from these installations seriously hamper the normal working.

- 3) Rigid mechanical ties between vibrating machine and building structure, short-

circuit or reduce the effectiveness of isolators. Loose and flexible connections should be inserted in all pipes and conduits leading from the vibrating machine. Where flexible connections are impracticable, bends should be inserted into the pipes or the pipes themselves should be supported on vibration mounts for a considerable distance from the source.

- 4) *Flexibility of foundation* — The effect of flexibility of the foundation on the isolator transmissibility shall be considered in the selection of practical vibration isolating mountings. The simplified vibration isolation theory assumes a completely rigid foundation. However, in practice, this can never be achieved. The foundation is never actually completely rigid. Generally, the relatively low stiffness of the isolation system permits the assumption of the foundation to be rigid. However, if the stiffness of the isolator is allowed to become comparable to the foundation stiffness (or greater), the deflection of the isolator will become smaller and the foundation will also deflect with increased transmissibility and decreased isolator efficiency. In a dynamic sense, supporting foundation or floors should have natural frequency as high and be as stiff as possible compared to the system being isolated. Good design practice requires that the isolators should be designed assuming a rigid foundation with the stipulation that the selected machine isolation system frequency should be well below the foundation frequency. This point should especially be kept in mind when installing machines at upper levels in buildings because supported slabs generally have lower natural frequencies (low stiffness) than slabs on grade in basement or ground floor locations.

10.4.4 Noise Reduction by Enclosures and Barriers

10.4.4.1 Enclosures

Airborne noise generated by a machine may be reduced by placing the machine in an enclosure or behind a barrier. The enclosure may be in the form of close-fitting acoustic box around the machine such that the operator performs his normal work outside the box and thus is not subjected to the high noise levels of the

machine. The enclosure may be made of sheet metal lined inside with an acoustical material.

Where size of the machine, working area and the operation do not permit close-fitting enclosures, the machine may be housed in a room of its own. The inside of the enclosure should be lined with sound-absorbing materials to reduce the noise level of the contained sound. The bounding walls of the enclosures shall also have adequate transmission loss to provide desired noise reduction.

10.4.4.2 Barriers

A partial reduction of noise in certain directions may be obtained by barriers or partial enclosures or partial height walls. Two-sided or three-sided barrier, with or without a top and invariably covered on the machine side with acoustic absorption material should face a wall covered with sound-absorbing material. If the top of the enclosure is open, the reduction may be increased by placing sound-absorbing material on the ceiling overhead.

10.4.5 Acoustical Absorption Devices

10.4.5.1 Acoustical treatment of ceilings and side walls

In order to reduce the general reverberant noise level in machine shops, acoustical material may be provided on as much of the available area on the ceiling and side walls. With this treatment 3 to 6 dB reduction of middle and high frequency noise may be achieved. While the noise level at the source, affecting the operator, may not be reduced materially, the treatment would bring down the built-up noise level away from the source in reverberant field.

10.4.5.2 Functional sound absorbers

For efficient noise reduction functional sound absorbers may be clustered as near the machines as possible. These units may be suspended and distributed in any pattern to obtain lower noise levels within the machine shop. Compared on the basis of equal total exposed surface areas, functional sound absorbers have higher noise reduction coefficients (NRC) than conventional acoustical materials placed directly on ceilings and walls.

11 LABORATORIES AND TEST HOUSES

11.1 Sources of Noise

11.1.1 Outdoor Noise

In a test house or laboratory, where research workers and scientists are engaged in performing sophisticated experiments, the external noise is mostly contributed by noise emitting buildings (workshops, machine rooms), airports, railway stations and general traffic noises. The outdoor sources of noise in a college

laboratory include noises produced in a playground as well.

11.1.2 Indoor Noise

The following sources mainly contribute to indoor noises in research institutions/college laboratories:

- a) Workshops, machine rooms, cafeteria, etc;
- b) Air conditioning and exhaust fans;
- c) Noise produced within the test house or laboratory while performing experiments; and
- d) Typing or other machine noises, telephone service, lift, sanitary services, etc.

11.2 Recommendations

11.2.1 Site Planning

While planning for a laboratory or test house, care should be taken in the design that no noise emitting installations should exist in its neighbourhood. However, where outdoor noises exist, such as from local factory, heavy traffic airports, railway lines, sport grounds or busy markets, buildings should be kept as far away as possible from the source of noise.

11.2.1.1 The window and door openings towards the noise sources should be minimum. Minimum amount of glazing should be placed on walls directly facing the noise sources.

11.2.2 Internal Planning

11.2.2.1 Noisy places should be kept separate from the quiet ones. The location of laboratories or test houses should be so chosen that it is cut off from the noisy zones. Where there are offices attached to a laboratory, provision should be made to treat the offices and to use acoustical partitions, to achieve a sound isolation D_w of at least 35 dB.

11.2.2.2 In a laboratory, mostly hard reflecting surfaces and bare furnishings are found, which produce very reverberant conditions. The noise condition still deteriorates when noise producing instruments are switched on or a heavy object is dropped on the floor. Under these conditions, sound absorbing treatment of the space is very essential. Sound absorbing ceilings are recommended to deaden such noises. Rubber buffers may also be fitted to the legs of furniture.

11.2.2.3 In large span laboratories or test houses where scientists and researchers are engaged in work and/or simultaneously busy in calculations or desk work requiring high degree of mental concentration, use of sound absorbing screens is recommended.

11.2.2.4 Noise reduction between the test house or laboratory and corridors or general circulation space should be well kept in mind and due care should be

taken of the type of doors and the manner of their fittings, etc. Transmission of noise through service ducts, pipes, lifts and staircases should also be guarded.

Telephones should preferably be placed in a separate small enclosure or acoustically efficient telephone booth.

11.2.2.5 To isolate a laboratory or a test house from structure-borne noises originating from upper floor, sandwich type floor construction is recommended.

11.2.2.6 Wherever the provision of double glazed windows is necessary to reduce the heat losses, care should be taken to provide sealed double windows rather than double glazing in a single window.

NOTE — Double glazed windows for sound insulation should have a minimum gap of 100 mm between the two glasses.

12 MISCELLANEOUS BUILDINGS

12.1 Law Courts and Council Chambers

It is important that law courts and council chambers be protected from the intrusion of outdoor noise and from indoor noise arising both from ancillary offices and circulation spaces. The general recommendations on site planning given in 3 apply to law courts and municipal buildings, but in the larger buildings at least, further protection against outdoor noise can be obtained by planning offices and other rooms around the court rooms or chambers, and separating the offices from the central rooms by means of corridors. This arrangement is usually convenient to the function of the buildings.

12.1.1 The wall between the corridors and the central rooms should have a sound reduction index, R_w of not less than 50 dB (for example 230 mm brick) to insulate against airborne noise in the corridors. Entrances from halls or corridors into court rooms or council chambers should be through baffle lobbies with two sets of quiet action doors. Sound absorbing treatment on ceilings and upper parts or walls or entrance lobbies is recommended.

12.1.2 The whole of the floor of the court room or chamber including steps and seating areas set aside for the public should have a resilient floor finish to reduce the noise of footsteps and shuffling of feet. Any tip-up seats should be quiet in action.

12.1.3 Sound absorbing treatment applied for acoustic purposes serves also to reduce the build-up of noise within the room. It is desirable to provide sound absorbing ceiling in the court room.

12.2 Libraries, Museums and Art Galleries

Quiet conditions for reading and study are essential in

these types of buildings and, since their occupancy is not noise producing, intruding noise is more noticeable and distracting. Every opportunity therefore should be taken to plan for noise defence, both in respect of siting of the building and internal planning. When possible, stack rooms, store rooms and administrative offices should be planned to screen reading rooms, print rooms and lecture rooms from noise sources. In public libraries, the reference library and lecture rooms should receive first consideration; the lending library, newspaper and periodical rooms have a higher background noise and are secondary in importance.

12.2.1 In large libraries, museums and art galleries echoes from lofty, large domed or concave ceilings are often a nuisance. Small noises such as footsteps, coughs, chair scraping and closing of books are reinforced by reverberation, and concave surfaces even when treated with a sound absorbent may focus these noises. Treated flat ceilings, if not too high, obviate these troubles. Books on shelves in libraries constitute a valuable wall absorbent.

12.2.2 Floor finishes are important. The impact noise of footsteps on marble, terrazzo or wood block flooring, and especially on hardwood strip and batten flooring, can be disturbing both within the room in which the noise is generated and the rooms below. On solid floors, resilient floor finishes, such as rubber, cork and linoleum on an underlay, are highly desirable. In the children's sections of libraries and museums they are essential. In existing buildings, rubber linoleum or vinyl asbestos tiles laid over the floor in the traffic areas are often a solution to the problem.

12.2.3 Reference libraries in universities, research establishments, office buildings and science buildings having machines and testing benches, should be planned in a quiet part of the building. Walls enclosing the library should normally have a sound reduction index, R_w of not less than 50 dB (for example 230 mm brick) and baffle lobbies should be planned between the library and halls and corridors. Walls facing on to corridors or other noisy areas should not have fanlights unless they are double glazed and non-operable.

12.3 Auditoria and Theatres

The sources of noise that have to be considered in concert halls, opera house, theatres and similar auditorium buildings are as follows:

- a) Outdoor noise entering through walls, roofs, doors, windows or ventilation openings;
- b) Noise from any other hall in the same building, especially if let out separately for revenue;
- c) Noise from foyers, service rooms and other ancillary rooms, particularly rehearsal rooms;

- d) Noise from air conditioning plant, etc, and the cross-transmission of other internal noises *via* ventilating duct system; and
- e) Impact generated noise due to rainfall on light weight metal roofs.

12.3.1 Because of greatly increased outdoor noise, all auditorium buildings now need more care in siting than formerly. For listening to speech or music, a very low background noise level is desirable; in concert halls especially the quietest possible conditions should be provided because the pauses and moments of silence which are essential elements of music cannot otherwise be given full value. Therefore, sites at crossroads or close to steel railway bridges, religious places or near churches where bell ringing is practiced, should be avoided unless very high standards of structural sound insulation are contemplated. Sites adjoining underground railways may also prove unsatisfactory at basement levels owing to low-pitched noise or rumble transmitted through the ground; special isolation measure need to be adopted for isolating large buildings from ground vibration of this sort.

12.3.2 Whenever possible, for concert halls and theatres on city sites a noise survey of the site should be made; a suitable sound reduction value for the structure of the building can then be chosen so as to keep down to certain maximum noise levels within the auditorium. The maximum octave-band sound pressure levels (SPL) recommended are given in Table 8.

Table 8 Maximum Sound Pressure Levels Due to External and Mechanical Equipment Noise in Auditoria (dB)
(Clause 12.3.2)

Sl No.	Type of Auditorium	Centre Frequency, Hz							
		63	125	250	500	1 000	2 000	4 000	8 000
(1)	(2)	(3)	(4)	(5)	(6)	(7)	(8)	(9)	(10)
i)	Concert halls [dBA-25]	51	39	31	24	20	17	14	13
ii)	Drama theatres and cinemas [dBA-30]	55	44	35	29	25	22	20	18

12.3.3 The minimum standard of sound reduction index, R_w likely to be required for the envelope of an auditorium in a city to protect it against external noise is of the order of 65 dB for a concert hall or 55-60 dB for a theatre. This reduction should be provided on all sides, but it would be reasonable to make the R_w for the roof 5 to 10 dB less provided the building is not unduly exposed to noise from aircraft in flight. Surrounding the auditorium with ancillary rooms and foyers is an obvious and invaluable planning method

of obtaining the required insulation against outdoor noise.

12.3.4 Ventilation intakes and returns are vulnerable features in the defence against external noise. They should be positioned so as to avoid exposure to noise, and in addition sufficient length of both inlet and outlet ducts should be provided with carefully designed silencers. The ventilation system should also be designed to avoid transmitting or adding to internal noise.

12.3.5 The most serious internal noise problem arises when there are two halls meant for separate use in the same building, especially if one of them is a concert hall. The latter is a very loud potential source of noise and requires a high standard of protection against extraneous noise. In these circumstances it is doubtful whether a ‘single’ wall can be adequate for insulating the two halls unless it is designed with a wide unbridged cavity. Separation by planning is preferable.

12.3.6 Other sources of internal noise are rehearsal rooms, scenery bays and workshops, stages of other halls where rehearsals or erection of stage sets might be in progress and foyers and bars where loud conversation might occur. The insulation of the internal walls should be adequate to protect the auditorium from these noise sources and the insulation should not be by-passed by openings, doorways, etc. The general noise due to banging of doors also needs to be taken care of; soft sealing materials should be provided for all doors to ensure quiet closing.

12.3.7 Mechanical equipment such as lifts shall be effectively isolated from the building structure to help avoid noise transmission.

12.3.8 Adequate damping shall be provided under light weight metal roofs with an additional light weight under deck noise sound barrier to reduce rainfall generated noise.

12.3.9 For detailed acoustical design of auditoria and conference halls reference may be made to good practice [8-4(3)].

12.4 Cinemas

The main objective of the design should be to control noise from adjacent screens, the projection area, the

foyer, and outside the cinema. The first of these, controlling noise from adjacent screens, is likely to be the most difficult with modern digital sound systems. As most cinemas are air conditioned, there will be some noise from services. To ensure reasonable listening conditions, this should be limited to 30 dBA. This will provide some masking of the noise from adjacent screens, but a high performance partition will still be essential. Masonry or lightweight construction may be used, and a typical performance specification for a lightweight wall separating two screens is given in Table 9. Cinema design, however, normally requires specialist acoustic advice.

Table 9 Typical Sound Insulation Specification for Wall Separating Two Cinema Screens
(Clause 12.4)

Sl No.	Octave band Hz	Sound Reduction Index, R dB
i)	63	38
ii)	125	44
iii)	250	50
iv)	500	61
v)	1 000	57
vi)	2 000	58
vii)	4 000	57
viii)	8 000	55

13 NOISE FROM BUILDING SERVICES

13.1 Mechanical, electrical, air conditioning, heating and mechanical ventilation, and other services are provided in almost all large buildings including residential, commercial and industrial buildings. Noise control measures should be incorporated during the design and installation of such services to adhere to the recommended outdoor and indoor noise criteria for the kind of occupancy. For detailed design of noise control for services, specialist advice should be sought.

Some basic design techniques for noise control in air conditioning, heating and mechanical ventilation system are given in Annex G.

13.2 Control of noise from mechanical equipment can also be done by specifying noise control requirements while purchasing the equipment (*see* Annex H).

ANNEX A

(Clause 2.4)

NOISE CALCULATIONS

A-1 GENERAL

Some of the simpler types of noise calculation are described in this annex.

A-2 ADDITION OF TWO NOISE LEVELS

To determine the combined sound pressure level (L_c) resulting from the sound pressure levels of two or more noise sources (L_1, L_2 , etc), it is necessary to calculate and add the mean square values of their individual sound pressures and then convert this back to a sound pressure level. This can be done using the following formula:

$$L_c = 10 \log_{10} (10^{L_1/10} + 10^{L_2/10})$$

As the individual sound pressure levels are logarithms of the mean square sound pressures, they cannot simply be added arithmetically. Figure 3 shows a graphical method for adding the sound pressure levels from two independent sources to obtain the combined sound pressure level at a particular place. This graph may also be used for multiple sources by combining sources two at a time to produce virtual sources that can then be combined. The most accurate approach is to start with the lowest levels and work towards the highest.

The graph should be used with caution where the noise sources are not independent. For example, the sound pressure level from two large transformers fed with currents in phase will be very sensitive to the receiving position. This is because the effect of the constructive

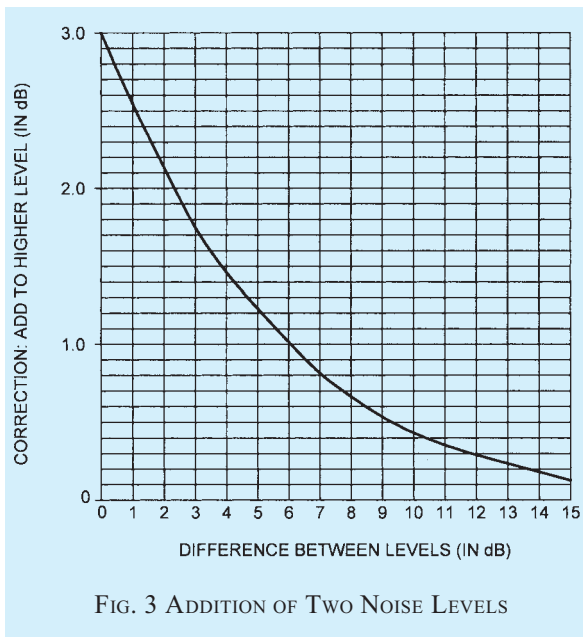

and destructive interference of the sounds from the two sources is very dependent on position.

A-3 SUBTRACTION OF TWO NOISE LEVELS

When measuring noise from a source, the true noise level of the source alone will be less than that shown by the meter, if the level of extraneous noise is less than about 10 dB below the total noise level. An estimate of the true source level can be obtained from Fig. 4.

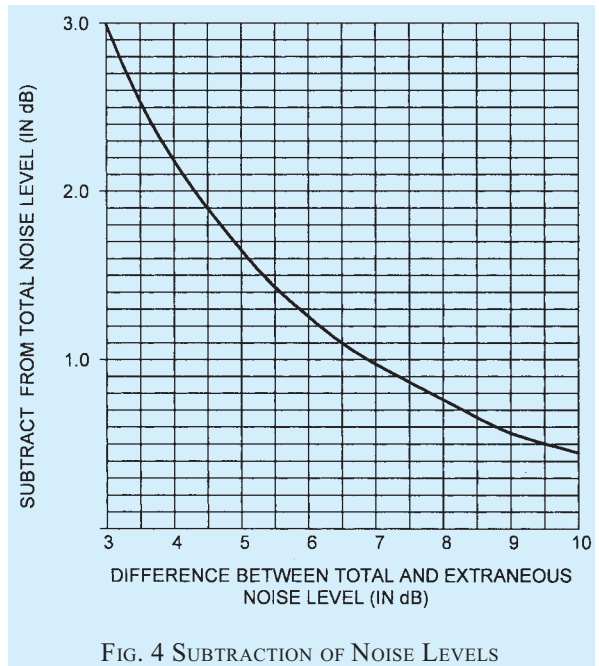

A-4 NON-UNIFORM COMPOSITE PARTITIONS

Figure 5 provides for calculating the overall sound insulation of a composite partition consisting of two parts having different sound-insulating properties, for example, a window in a wall. It may also be used to give an indication of the effect of gaps or holes in a partition by assigning a sound insulation value of 0 dB to the aperture.

A-5 A-WEIGHTING CALCULATIONS

The equivalent A-weighted level is often required when data on a noise source is available as a set of octave band or one-third octave band levels. The conversion can be done manually, using the standard A-weighting values (see Table 10) and the graph for combining levels (see Fig. 3). For all but the simplest situations it is more convenient to use a computer spreadsheet to do the conversion.

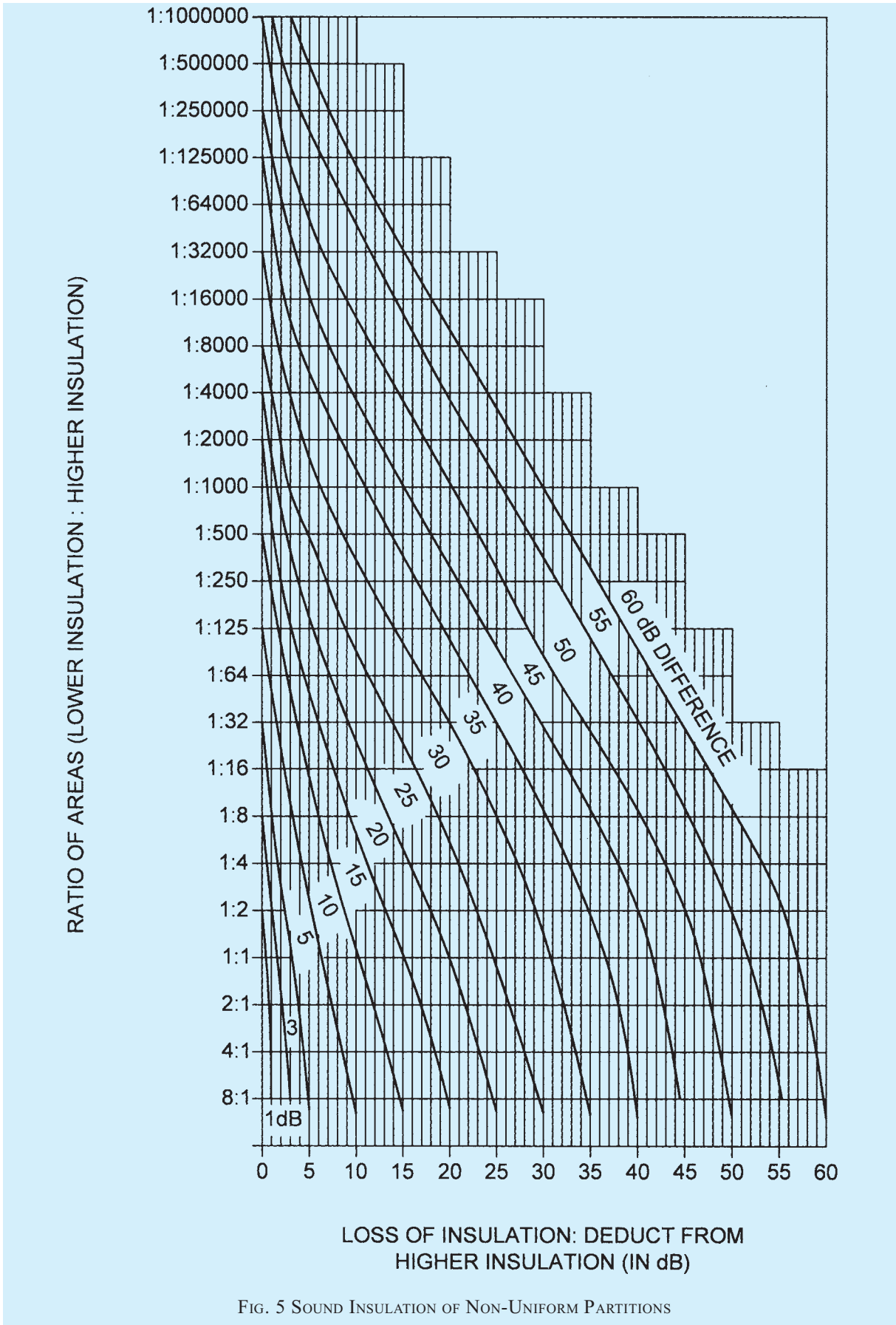

FIG. 5 SOUND INSULATION OF NON-UNIFORM PARTITIONS

Table 10 Standard A-Weighting Values (dB)
(Clause A-5)

SI No.	Third Octave Band Centre Frequency	A-Weighting	Third Octave Band Centre Frequency	A-Weighting
(1)	Hz (2)	dB (3)	Hz (4)	dB (5)
i)	10	-70.4	500	-3.2
ii)	12.5	-63.4	630	-1.9
iii)	16	-56.7	800	-0.8
iv)	20	-50.5	1 000	0
v)	25	-44.7	1 250	0.6
vi)	31.5	-39.4	1 600	1.0
vii)	40	-34.6	2 000	1.2
viii)	50	-30.2	2 500	1.3
ix)	63	-26.2	3 150	1.2
x)	80	-22.5	4 000	1.0
xi)	100	-19.1	5 000	0.6
xii)	125	-16.1	6 300	-0.1
xiii)	160	-13.4	8 000	-1.1
xiv)	200	-10.9	10 000	-2.5
xv)	250	-8.6	12 500	-4.3
xvi)	315	-6.6	16 000	-6.6
xvii)	400	-4.8	20 000	-9.3

A-6 REVERBERATION TIME CALCULATION

An estimate of the reverberation time (*T*) of a room

can be obtained from the Sabine formula:

$$T = \frac{(0.16V)}{\sum A_i}$$

where

- V* = volume of the room, in cubic metre (m³); and
- A_i* = equivalent sound absorbing area in the room, in square metre (m²).

The *A_i* are the absorbing areas of each surface, or other permanent fixture in the room. Each *A_i* is determined by multiplying the area of that surface in square metre (m²) by its absorption coefficient α_{si} . The surface of each significant fixture or feature of the room should be considered as well as the walls, ceiling and floor.

The total absorption is obtained by summing the individual *A_i* values. As the values of α_{si} are frequency dependent, this calculation should be repeated for each octave band of interest.

An allowance should also be made for people and furnishings in the room.

ANNEX B

(Clauses 2.26, 2.41, 2.44, 2.46, 2.54, 2.55, 2.56 and 2.57)

SPECIFICATION OF SOUND INSULATION

B-1 GENERAL

Sound insulating elements work mainly by reflecting sound energy back into the source room, not by absorbing it. The methods of measurement and the terms used are described in **B-2** to **B-4**.

B-2 INSULATION AGAINST AIRBORNE SOUND

As per the standard tests, the insulation between a pair of rooms is measured either in third octave bands having centre frequencies which cover at least the range 100 Hz to 3 150 Hz, or in octave bands which cover at least the range 125 to 2 000 Hz. The noise is produced by a loudspeaker in one of the rooms (called the source room) and at each frequency the average noise levels are measured in the source room (*L_S*) and in the adjacent receiving room (*L_R*). The difference between these two levels (*D*) is a measure of the sound insulation between the rooms regardless of the transmission path(s) the sound energy followed to travel between the rooms. The equation is as follows:

$$D = L_S - L_R$$

The actual level in the receiving room depends on the following:

- a) Sound insulation of the separating wall or floor;
- b) Area of the separating wall or floor;
- c) Volume of the receiving room;
- d) Amount of flanking transmission (that is the importance of transmission paths other than the separating wall or floor); and
- e) Amount of absorbing material (for example furniture) in the receiving room.

For field measurements, apart from the amount of absorption, these factors are a property of the building and should be taken into account by the measurement procedure. As the amount of absorbing material (for example soft furniture) in the room at the time of measurement is arbitrary, it should be allowed for separately. This is achieved by measuring the reverberation time (*T*) of the room in second (in s), which is a measure of how long it takes a sound to die away after the source has been switched off. As the sound energy is dissipated as heat in the absorbing

material (T), it is related to the total amount of absorption in the room. The receiving room level may then be corrected to the level it would be if the room had a standard reverberation time (T_0) which is typical of furnished rooms, and is taken to be 0.5 s. The corrected level difference is known as the standardized level difference, which has the symbol D_{nT} and is calculated using the following equation:

$$D_{nT} = L_S - L_R + 10 \log_{10}(T/T_0)$$

For laboratory measurements, the insulation of the separating wall or floor being tested is required in a way which is independent of the actual measuring laboratory. For this reason, laboratories are designed to have minimal flanking transmission and a different correction is applied to account for the other factors. This correction is $10 \log_{10}(S/A)$.

where

- S = common area of the separating wall or floor, in square metre (m^2); and
- A = equivalent absorption area in the receiving room, in square metre (m^2).

The laboratory corrected level difference at each frequency is known as the sound reduction index, which has the symbol R and is calculated using the following equation:

$$R = L_S - L_R + 10 \log_{10}(S/A)$$

If the test wall or floor is mounted in a realistic way in the laboratory and flanking transmission will be low in the field, the sound reduction index may be used to predict its performance in the field. The relation between D_{nT} and R is given by the following equation:

$$D_{nT} = R - 10 \log_{10}(3S/V)$$

where

- S = area of the separating wall or floor in the field, in square metre (m^2); and
- V = volume of the receiving room in the field, in cubic metre (m^3).

This equation shows that if the source and receiving rooms have different volumes, D_{nT} will depend on which is used as the source room; using the larger room as the source room will give lower value.

B-3 INSULATION AGAINST IMPACT SOUND

The procedure to measure the impact insulation of floors is rather different. Instead of a loudspeaker, a machine containing five small hammers is placed on the floor. While the hammers strike the floor at a rate of 10 blows a second, the resulting noise level (L_i) is measured in the receiving room below at each of the

same frequency bands used for airborne insulation. In the field, the receiving room levels are again ‘corrected’ to a standard reverberation time (T_0) of 0.5 s to give the standardized impact sound pressure level, L_{nT} , which is calculated as follows:

$$L_{nT} = L_i - 10 \log_{10}(T/T_0)$$

In the laboratory, the noise level depends mainly on the characteristics of the floor being tested and the amount of absorption (A m^2) in the laboratory. It is therefore appropriate to correct the noise level to a standard area of absorption. The area used is 10 m^2 . The resulting normalized impact sound pressure level is given the symbol L_n and calculated as follows:

$$L_n = L_i + 10 \log_{10}(A/10)$$

B-4 RATING SOUND INSULATION

Measurements of insulation against both airborne and impact sounds yield values in a number of frequency bands. To make this information more manageable, rating methods such as those in accordance with good practice [8-4(1)] are used to reduce the frequency band values to single figure ratings. These single figure ratings should be good predictors of subjective assessments of insulation. However, this is not always the case and it is prudent to examine the full measurement data in critical situations. The impact insulation measured on a floor with a carpet is likely to be overestimated by this method.

The more common indices used to describe sound insulation are summarized in Table 11.

Table 11 Common Indices Used to Describe Airborne and Impact Sound Insulation
(Clause B-4)

Sl No.	Air-borne (A) Impact (I)	Lab (L) Field (F)	Measured Values		Single Number Quantity	
			Name	Symbol	Name	Symbol
(1)	(2)	(3)	(4)	(5)	(6)	(7)
i)	A	F	Standardized level difference	D_{nT}	Weighted standardized level difference	$D_{nT,w}$
ii)	A	L	Sound reduction index	R	Weighted sound reduction index	R_w
iii)	I	F	Standardized impact sound pressure level	L'_{nT}	Weighted standardized impact sound pressure level	$L'_{nT,w}$
iv)	I	L	Normalized impact sound pressure level	L'_n	Weighted normalized impact sound pressure level	$L'_{n,w}$

ANNEX C
(Clause 2.24)
NOISE RATING

C-1 Noise rating (NR) is a graphical method for assigning a single number rating to a noise spectrum. It can be used to specify the maximum acceptable level in each octave band of a frequency spectrum, or to assess the acceptability of a noise spectrum for a particular application. The method was originally proposed for use in assessing environmental noise, but was later also found suitable for describing noise from mechanical ventilation systems in buildings. To make a rating, the noise spectrum is superposed on a family of NR contours; the NR of the spectrum corresponds to the value of the first NR contour that is entirely above the spectrum. The data for drawing NR contours (from NR 0 to NR 75) is given in Table 12 for the frequency range 31.5 Hz to 8 kHz.

Table 12 Noise Rating Values
(Clause C-1)

Sl No.	Noise Rating	Octave Band Centre Frequency, Hz Sound Pressure Levels dB _r , 20 µPa									
		31.5	63	125	250	500	1 000	2 000	4 000	8 000	
(1)	(2)	(3)	(4)	(5)	(6)	(7)	(8)	(9)	(10)	(11)	
i)	NR75	106	95	87	82	78	75	73	71	69	
ii)	NR70	103	91	83	77	73	70	68	66	64	
iii)	NR65	100	87	79	72	68	65	62	61	59	
iv)	NR60	96	83	74	68	63	60	57	55	54	
v)	NR55	93	79	70	63	58	55	52	50	49	
vi)	NR50	89	75	66	59	53	50	47	45	43	
vii)	NR45	86	71	61	54	48	45	42	40	38	
viii)	NR40	83	67	57	49	44	40	37	35	33	
ix)	NR35	79	63	52	45	39	35	32	30	28	
x)	NR30	76	59	48	40	34	30	27	25	23	
xi)	NR25	72	55	44	35	29	25	22	20	18	
xii)	NR20	69	51	39	31	24	20	17	14	13	
xiii)	NR15	66	47	35	26	19	15	12	9	7	
xiv)	NR10	62	43	31	21	15	10	7	4	2	
xv)	NR5	59	39	26	17	10	5	2	-1	-3	
xvi)	NR0	55	35	22	12	5	0	-4	-6	-8	

C-2 For computational methods the curves are defined by the equation:

$$L = a + bN$$

where

L = octave band sound pressure level corresponding to NR level N ; and

a and b = constants for each frequency band, as given in Table 13.

NOTE — NR values cannot be converted directly to dBA values but the following approximate relationship applies:

$$NR = dBA - 6$$

C-3 Although the NR system is currently the preferred method for rating noise from mechanical ventilation system, other methods which are more sensitive to noise at low frequencies are available, but they are not yet widely accepted. Low frequency noise may be disturbing or fatiguing to occupants, but may not have much effect on the dBA or NR value.

Table 13 Values of a and b
(Clause C-2)

Sl No.	Octave Band Centre Frequency Hz	a	b
(1)	(2)	(3)	(4)
i)	31.5	55.4	0.681
ii)	63	35.4	0.790
iii)	125	22.0	0.870
iv)	250	12.0	0.930
v)	500	4.2	0.980
vi)	1 000	0.0	1.000
vii)	2 000	-3.5	1.015
viii)	4 000	-6.1	1.025
ix)	8 000	-8.0	1.030

ANNEX D

(Clause 3.3)

OUTDOOR NOISE REGULATIONS IN INDIA

D-1 Government notifications are issued from time to time on the allowable ambient noise levels in general and specifically in different zones of various metropolitan cities of India.

D-2 Noise regulations and notifications are also issued from time to time specifying the maximum permissible sound levels from equipment commonly used in and

around the residential areas and around sensitive buildings, specifically with regard to noise levels from electricity generating sets, construction equipment and HVAC utility equipment installed outdoors.

D-3 These regulations should be referred to by the designer for the design of measures for control of external noise.

ANNEX E

(Clauses 3.8 and 4.5)

SPECIAL PROBLEMS REQUIRING EXPERT ADVICE

E-1 GENERAL

Certain design problems require reliable advice of a kind which is not easy to find in published material. The advice of an expert should be sought for these kinds of problems, some examples of which are given in **E-2** to **E-9**.

E-2 ACOUSTIC TEST ROOMS

The design of rooms in which acoustic measurements are carried out, such as reverberation chambers, free-field anechoic rooms and audiometric test rooms, usually requires the advice of an expert.

E-3 PERFORMING SPACES

The design of theatres, opera houses, concert halls and similar performing spaces usually requires expertise in room acoustics and noise control. The intrusion of quite low levels of noise may seriously interfere with the enjoyment of the performance and distract the performers. The requirements for low noise levels often mean that more room has to be allocated for low velocity ventilation ductwork and the impact on the design of the ventilation system is often substantial.

E-4 BROADCASTING AND RECORDING STUDIOS

Broadcasting and recording studios have requirements similar to those of performing spaces. For some infrequent intrusive noises, the requirements are sometimes relaxed on the grounds that a retake of a recording can be done, but this can result in higher operating costs.

E-5 AIRCRAFT NOISE

As there are many variables affecting the level of aircraft noise heard on the ground, expert advice is almost always required. Contours of daytime $L_{Aeq,T}$ levels are available from most major airports. Where measurements of façade insulation are necessary a standard test method may be referred.

E-6 GROUND-BORNE NOISE

Projects involving ground-borne noise from underground trains usually require expert advice.

E-7 LOW FREQUENCY NOISE

Projects involving low-frequency noise usually require expert advice as accurate measurement is difficult and there is a shortage of reliable data below 100 Hz.

E-8 ACTIVE NOISE CONTROL

Active noise control is the reduction of noise by cancellation with a similar noise (anti-noise) generated by electro-acoustic means. The technique is still under development, but commercial systems are available which successfully reduce low frequency noise from mechanical ventilation systems.

E-9 NOISE SURVEYS

Noise surveys are carried out for a variety of reasons, for example,

- a) Before construction, to establish the existing noise climate at the site of a proposed development where reliable prediction is

- impracticable, as an aid to the design of the building envelope, either to protect against external noise or contain internally produced noise;
- b) During construction, to monitor noise from building activity, either to assess the likely nuisance to the local community or the risk of hearing damage to the work force;
 - c) At the end of a building contract to check the insulation of the building envelope, or the noise levels produced by the services;
 - d) As part of a planning requirement;
 - e) To provide objective evidence to support or defend a legal action.

The expense of carrying out a comprehensive noise survey of any kind is likely to be high, so the cost-effectiveness of a full or partial survey should be weighed against alternatives such as prediction. A survey will generally be more accurate and can take account of factors such as prevailing wind conditions.

ANNEX F

(Clause 4.4)

AIRBORNE AND IMPACT SOUND INSULATION

F-1 GENERAL

Airborne sound refers to sources which produce sound by directly setting the air around them into vibration. Impact sound refers to sources which produce sound by impulsive mechanical excitation of part of a building (for example by footsteps, electric light switches, slamming doors). Many sources of impact sound also produce significant levels of airborne sound. The term structure-borne sound has no very precise meaning as the structure can be excited by both airborne and impact sources; it is often used to refer to sound that travels for long distances *via* the structure, especially in connection with vibrating machinery linked directly to the structure.

F-2 DIRECT AND INDIRECT TRANSMISSION

Figure 6 shows diagrammatically a pair of rooms in a house where the construction consists of solid walls, etc, bonded together. Sound travelling from room 1 to room 2 may travel *via* the direct path a-a and by the many indirect, or flanking, paths shown. The term flanking transmission is usually used to mean transmission paths involving the structure, while the term indirect transmission includes flanking paths and airborne paths through gaps and ducts, etc. The indirect paths may limit the sound insulation attainable no matter how much the direct sound is reduced by the separating wall or floor. The indirect transmission can be reduced by measures such as the following:

- a) Increasing the mass of the flanking walls;
- b) Increasing the mass of the partition and bonding it to the flanking walls;

- c) Introducing discontinuities in the indirect paths;
- d) Erecting independent wall linings adjacent to the flanking walls to prevent energy entering the flanking construction; and
- e) Sealing any air gaps and paths through ducts.

Figure 7 shows a number of indirect paths that have been found in offices.

It is important to remember that standard test laboratories are designed to minimise transmission by all paths other than the direct path. This makes it difficult to relate the results of laboratory measurements to those likely to be obtained in the field.

F-3 AIRBORNE SOUND INSULATION

F-3.1 General

The sound insulation of structural elements such as walls and floors always varies with frequency, the insulation rising in general as the frequency rises.

F-3.2 Terminology

Results from field measurements are usually expressed in terms of the weighted standardized level difference, while laboratory measurements are usually expressed in terms of the sound reduction index. In the absence of significant flanking transmission, the numerical difference between the weighted standardized level difference and the sound reduction index of a wall or floor is usually small for furnished rooms in dwellings, and so either quantity may be used in considering principles; for this purpose it is, therefore, convenient

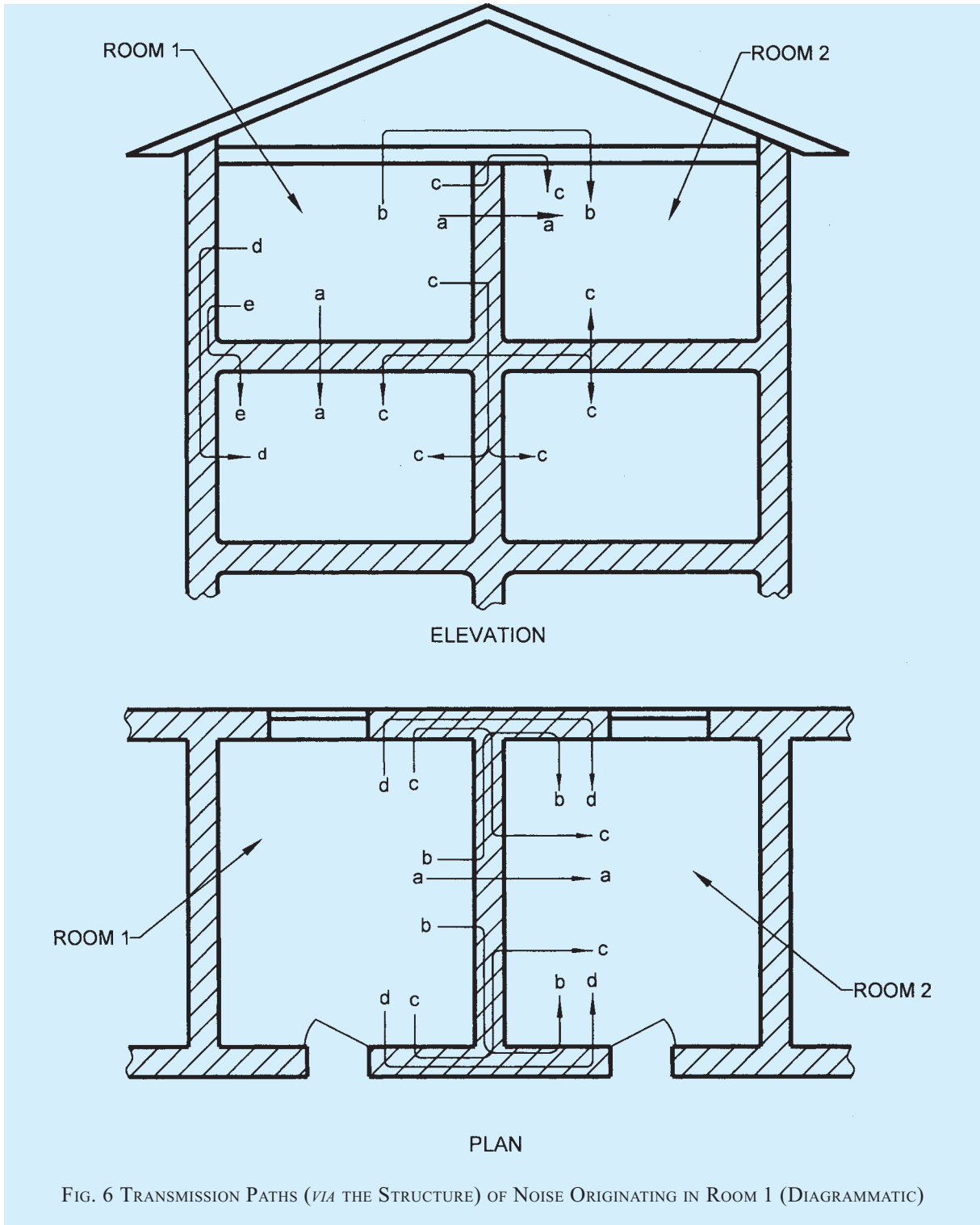

FIG. 6 TRANSMISSION PATHS (VIA THE STRUCTURE) OF NOISE ORIGINATING IN ROOM 1 (DIAGRAMMATIC)

to use the general term insulation.

F-3.3 Mass Law

An approximate empirical relationship has been established between sound insulation and mass for single leaf constructions as shown in Fig. 8. This so called ‘Mass Law’ gives a useful first approximation

to the behaviour of a single sheet or plate. In practice, the sound insulation predicted by the mass law may not be attained because of factors such as the coincidence effect, which is outlined in F-3.4. Results for specific materials vary around the value given by the Mass Law relationship, and so measured data should be used when available. Table 14 gives a lists of materials and indicates the sound insulation of a single,

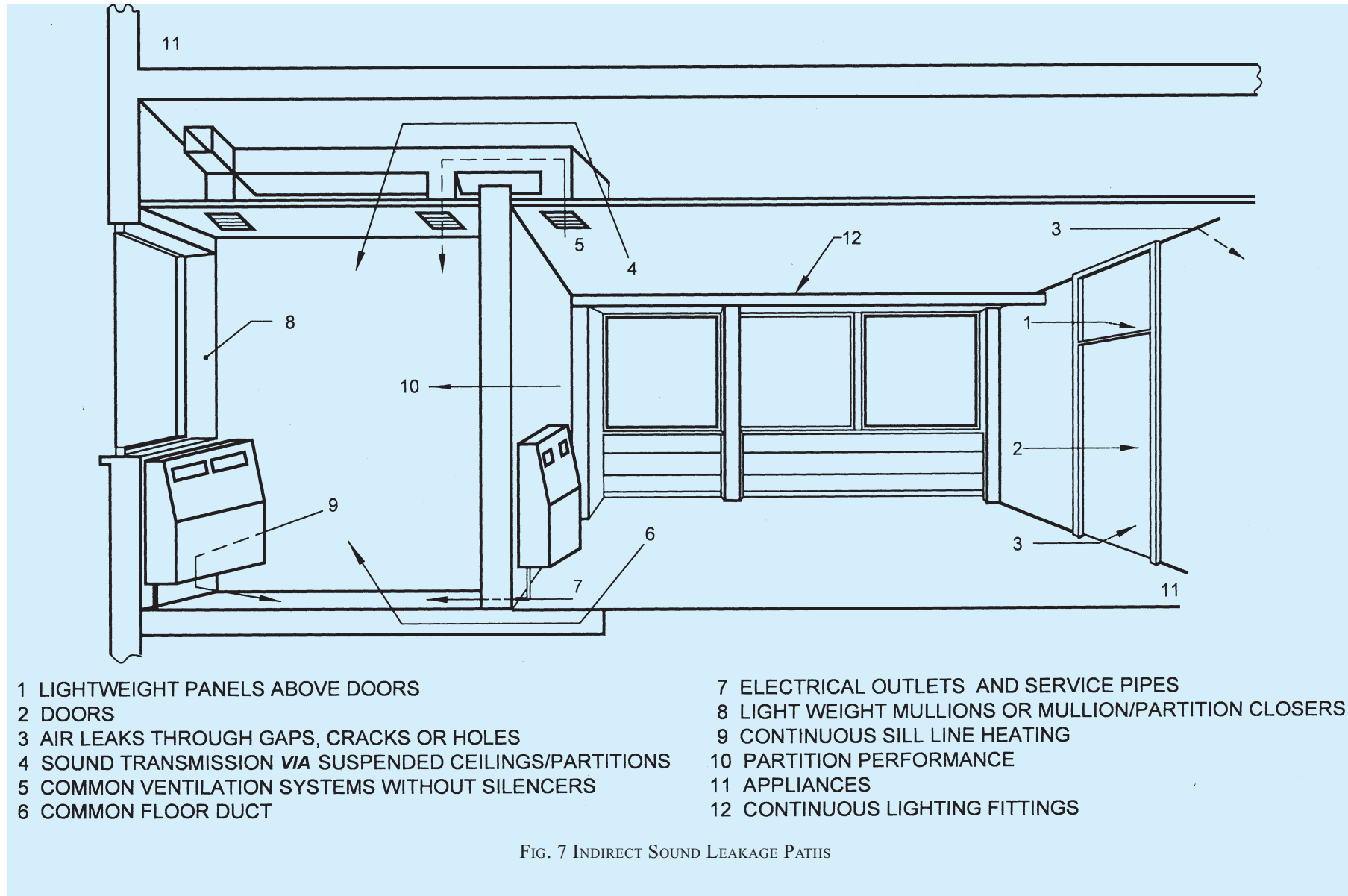

FIG. 7 INDIRECT SOUND LEAKAGE PATHS

imperforate sheet when fixed to a suitable wood or metal framework. These values are useful, for example when assessing existing structures.

Table 14 Sound Insulation of Imperforate Sheet Materials
(Clause F-3.3)

SI No.	Material	Surface Mass kg/m ²	Typical Weighted Sound Reduction Index R_w dB
(1)	(2)	(3)	(4)
i)	3 mm glass sheet	7.0	26
ii)	12.5 mm plasterboard	10.5	31
iii)	18 mm wood particle board	8.0	27
iv)	19 mm plywood	3.0	24
v)	16 mm plywood	4.5	24
vi)	1 mm steel sheet	11.0	29
vii)	6 mm hardboard	5.0	25
viii)	12 mm wood fibre insulation board	4.0	24
ix)	13 mm mineral fibre board	4.0	24
x)	50 mm wood-wool screeded one side	35.0	33

F-3.4 Coincidence Effect

The coincidence effect occurs when the wavelength of the wave impressed on the panel by the incident sound wave is close to the wavelength of free bending waves in the panel. The effect of coincidence is to lower the sound insulation of a construction by as much as 10 dB below the level expected from its mass per unit area over a limited frequency range. The coincidence effect

can be pronounced with thin light weight partitions, resulting in loss of insulation at middle and high frequencies. Reducing the stiffness without a corresponding reduction of mass can raise the critical frequency above 3 150 Hz, and so improve the insulation over the important 100 Hz to 3 150 Hz range. An increase of stiffness will have the reverse effect.

It is possible to design lightweight stud partitions so that they perform to their maximum effect in the speech frequency region between 250 Hz and 2 000 Hz, that is between the mass-spring-mass and coincidence regions respectively.

The worst coincidence dips occur in materials such as plate glass and rigid metal sheets. Heavily damped materials such as lead sheets are least affected.

F-3.5 Mass-Spring-Mass Frequency

A double leaf wall can perform better than a single leaf wall of similar mass because the sound has to pass through two barriers. If the two leaves are not connected to each other, the insulation values of the two leaves may be added together. However, in practice the leaves are often connected by ties or studs, and the full insulation cannot be achieved. Even where the two leaves are isolated from each other, the full benefit can only be obtained above a certain frequency that depends on the cavity width. This is because the air in the cavity behaves like a spring connecting the leaves together, and causes a resonance at the mass-spring-mass frequency. Below this frequency, the two leaves behave more like an equivalent single leaf.

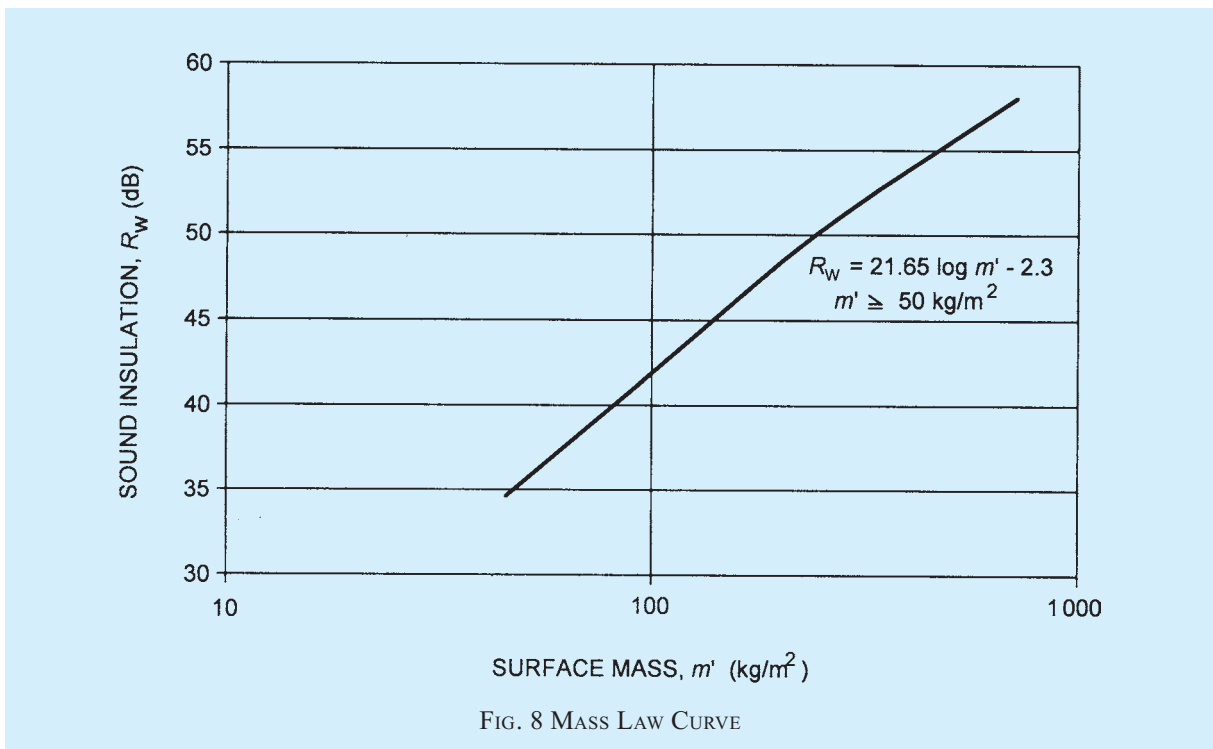

Making the cavity width wide can reduce the mass-spring-mass frequency, as in the case of sound insulating secondary glazing. The mass-spring-mass frequency (F_0) may be estimated from the following equation:

$$F_0 = 59.6 \sqrt{\frac{1}{d} \left(\frac{1}{m_1} + \frac{1}{m_2} \right)}$$

where

m_1 and m_2 = surface masses of the two leaves, in kilogram per square metre (kg/m^2); and

d = cavity width, in metre (m).

F-3.6 Impact Sound Control

A structure that receives an impact or has a vibrating source in contact with it behaves more like an extension of the source rather than an intervening element between source and listener. For this reason, a relatively small amount of impact energy may produce a loud sound and, if the structure is continuous, the sound may travel a long distance. Control is usually obtained by inserting a resilient surface at the point of contact with the source (for example laying a carpet on a floor) or by introducing a structural discontinuity.

Floating floors, which are an example of the latter approach, are a common method of controlling impact sound from footsteps. However, it should be noted that an effective floating floor may result in increased sound from impacts on the source side of the floor.

F-4 AIRBORNE INSULATION VALUES OF WALLS AND AIRBORNE AND IMPACT INSULATION VALUES OF FLOORS

Table 15 and Table 16 give examples of common types of wall and floor construction with sound insulation in the ranges shown. The insulation indices are for field measurements accessed in accordance with good practice [8-4(4)]. The insulation values given are necessarily approximate since examples of nominally identical constructions may show variations of several decibels. All the figures represent values expected in the field, that is, in actual buildings. Many are based directly on field measurements, though other (in the absence of representative field measurements) have been assessed from laboratory data, with an allowance for typical flanking conditions in normal buildings. Variation in the amount of indirect transmission may affect significantly the insulation between two rooms separated by a given barrier. For example, the sound insulation of some types of floor may be reduced by indirect transmission along the walls supporting them, particularly if these walls are of lightweight masonry

and carried past the floor.

In many cases, simple solid partitions give insulation values according to their mass (*see F-3.3*). Moreover, with partitions of this type there is usually little variation between field and laboratory test results unless the laboratory insulation exceeds 45 dB. Exceptions may occur in buildings that have not been specially designed to minimise common cavities and strongly coupled elements in lightweight panelling. The examples given are not exhaustive. Flanking structures are not listed since these can vary widely and are often dependent upon other factors such as thermal insulation, which are outside the scope of this Code.

Table 15 Airborne Sound Insulation of Walls and Partitions
(Clause F-4)

SI No.	Sound Insulation $D_{nT,w}$ dB	Type of Wall or Partition
(1)	(2)	(3)
i)	26 to 33	a) 1 mm steel sheet panels fixed to steel frame members to form demountable partition units 50 mm overall thickness. Mineral wool cavity insulation b) Plywood or wood fibre board 12 mm thick nailed both sides of 50 mm × 50 mm timber framing members spaced at 400 mm centres c) Paper faced strawboard or wood wool 50 mm thick panels plastered both sides d) Chipboard hollow panels 50 mm thick tongued and grooved edges, hardboard faced. Joints covered with wood trim
ii)	33 to 37	a) Lightweight masonry blockwork, plaster or drylining on at least one side. Overall mass per unit area not less than 50 kg/m^2 b) Laminated plasterboard at least 50 mm thick fixed to timber perimeter framing, any suitable finish. Approximate mass per unit area 35 kg/m^2 c) Timber stud partitions any size timbers greater than 50 mm × 50 mm, 400 mm centres, cross noggins, 9.5 mm plasterboard lining on both sides, any suitable finish d) Metal stud partition, 50 mm studs 600 mm centres, clad both sides with 12.5 mm plasterboard, joints filled and perimeters sealed. Approximate mass per unit area 18 kg/m^2 e) 50 mm lightweight masonry blockwork, plastered both sides to 12 mm thickness or drylined with 9.5 mm plasterboard
iii)	37 to 43	a) Lightweight masonry blockwork, plaster or dry lining on at least one side. Overall mass per unit area not less than 75 kg/m^2 b) Metal stud partition, 50 mm studs 600 mm centres, clad both sides with 12.5 mm plasterboard, joints filled and perimeters sealed. 25 mm mineral fibre quilt hung between studs. Approximate mass per unit area 18 kg/m^2

Table 15 — (Continued)

(1)	(2)	(3)
iv)	43 to 50	<p>a) Masonry wall, joints well filled. Either plaster or dry lining on both sides. Overall mass per unit area not less than 150 kg/m²</p> <p>b) 100 mm metal stud partition, 'C' section studs not greater than 600 mm spacing, not less than nominal 50 mm web depth. Clad on both sides with two layers of plasterboard of not less than 25 mm combined thickness. Mineral fibre quilt hung between studs. Approximate mass per unit area 35 kg/m²</p> <p>c) 75 mm × 50 mm timbers framing using staged studs at 300 mm spacing with 25 mm stagger forward and back. Frame clad with two layers of 12.5 mm of plasterboard on both sides. Mineral fibre quilt hung between studs. Approximate mass per unit area 36 kg/m²</p> <p>d) 50 mm × 25 mm timber stud partition to form a 25 mm cavity, clad on both sides with minimum 38 mm wood wool slabs having their outer faces screeded or plastered</p> <p>e) Solid autoclaved aerated concrete block 215 mm thick plaster or dry lined finish on both sides, blockwork joints well filled. Overall mass per unit area not less than 160 kg/m²</p>
v)	50 to 54	<p>a) Two separate frames of timber studs not less than 89 mm × 38 mm, or boxed metal studwork with 50 mm minimum web depth. Studs at 600 mm maximum centres. A 25 mm mineral wool quilt suspended between frames. Frames spaced to give a minimum 200 mm overall cavity. Clad on outside of each frame with a minimum of 30 mm plasterboard layers (for example 19 mm plus 12.5 thickness). Approximate mass per unit area 54 kg/m² ¹⁾</p> <p>b) Either <i>in-situ</i> or pre-cast concrete wall panel not less than 175 mm thick and not less than 415 kg/m². All joints well filled¹⁾</p> <p>c) Brick wall nominal 230 mm thickness, weight (including plaster) not less than 380 kg/m². Plaster or dry-lined finish both sides. Brick work joints well filled¹⁾</p> <p>d) 'No fines' concrete 225 mm thickness, weight (including plaster) not less than 415 kg/m². Plaster or dry-lined finish both sides¹⁾</p> <p>e) Cavity lightweight aggregate block (maximum density of block 1 600 kg/m³) with 75 mm cavity and wall ties of the butterfly wire type. Dry lined finish on both sides. Joints in blockwork well filled. Overall mass per unit area not less than 300 kg/m² ¹⁾</p> <p>f) Dense aggregate concrete block cavity wall with 50 mm cavity and wall ties of the butterfly wire type. Dry lined finish on both sides. Joints in block work well</p>

Table 15 — (Concluded)

(1)	(2)	(3)
		<p>filled. Overall mass per unit area not less than 415 kg/m² ¹⁾</p> <p>g) Autoclaved aerated concrete block cavity wall consisting of two leaves, 100 mm blocks not less than 75 mm apart, with wall ties of the butterfly type. Plaster or dry line finish on both sides. Joints in blockwork well filled. Overall mass per unit area not less than 150 kg/m² ¹⁾</p>
vi)	54 to 60	<p>a) Two separate frames of timber studs not less than 100 mm × 50 mm spaced at 600 mm maximum centres. A 50 mm mineral wool quilt in each frame between studs. Frames spaced to give a minimum 300 mm overall cavity. Each frame clad on outside with three layers of 12.5 mm plasterboard nailed to framing. Approximate mass per unit area 51 kg/m² ¹⁾</p> <p>b) Two separate frames of boxed 'C' section galvanized nominal 150 mm steel studs 100 mm apart with a 400 mm overall cavity. 50 mm mineral wool quilt fixed to the back of one frame each frame clad on outside with three layers of 12.5 mm plasterboard by self drilling or tapping screws. Approximate mass per unit area 47 kg/m² ¹⁾</p> <p>c) Solid masonry with an overall mass per unit area of not less than 700 kg/m² fully sealed both sides ¹⁾</p> <p>d) Dense aggregate concrete block solid wall 215 mm thick plaster finish to both surfaces. Overall mass per unit area not less than 415 kg/m² ¹⁾</p> <p>e) Cavity lightweight aggregate block (maximum density of block 1 600 kg/m³) with 75 mm cavity and wall ties of the butterfly wire type. Plaster finish on both sides. Joints in blockwork well filled. Overall mass per unit area not less than 300 kg/m² ¹⁾</p> <p>f) Dense aggregate concrete block cavity wall with 50 mm cavity and wall ties of the butterfly wire type. Plaster finish on both sides. Joints in blockwork well filled. Overall mass per unit area not less than 415 kg/m² ¹⁾</p>
<p>NOTES</p> <p>1 Construction details and workmanship are important, if the levels of sound insulation indicated are to be achieved.</p> <p>2 Where plasterboard is specified it is assumed that the surface mass will be at least 6.5 kg/m² for 9.5 mm thick board, at least 8.5 kg/m² for 12.5 mm thick board, and at least 14.5 kg/m² for 19 mm thick board. If less dense plasterboard is used, the thickness should be increased.</p>		
<p>¹⁾ When considering these constructions for separating walls, expert advice should be sought.</p>		

Table 16 Airborne and Impact Sound Insulation of Floor Constructions
(Clause F-4)

Sl No.	Sound Insulation dB	Type of Floor Construction
(1)	(2)	(3)
i)	$D_{nT,w} = 49$ to 54 $L'_{nT,w} = 56$ to 65	<p>a) A concrete floor having mass per unit area not less than 365 kg/m², including any screed or ceiling finish directly bonded to the floor slab; together with a floating floor or resilient floor covering equivalent to rubber or sponge rubber underlay or thick cork tile (for example carpet and underlay or sponge rubber backed vinyl flooring)</p> <p>b) A solid floor consisting of,</p> <ol style="list-style-type: none"> 1) a solid slab; or 2) concrete beams and infilling blocks; or 3) hollow concrete planks; together with a floating floor. A ceiling finish is required for a beam and block floor. In each case the slab should have a mass per unit area of at least 300 kg/m², including any screed or ceiling finish directly bonded to it. <p>Where a floating floor is laid over a floor of beams and hollow infill blocks or hollow beams along the top of the structural floor, it should be sealed and levelled before the resilient layer is put down. It is also essential to have due regard for conduits and pipework which should be laid and covered so as to prevent any short circuit of the floor's isolating properties.</p> <p>If precast units are used as a structural floor, it is essential that the joints are filled to ensure that the sound insulation performance is maintained.</p> <p>The resilient material is laid to cover completely the structural floor and turned up against the surrounding wall along all edges. The resilient layer is usually of mineral fibre, or a special grade of expanded polystyrene. When the screed is laid, it is important that none of the mix finds its way through the resilient layer to the structural floor, as this will short circuit the isolation between the two decks and</p>

Table 16 — (Concluded)

(1)	(2)	(3)
		significantly reduce the sound insulation
		c) A floor consisting of boarding nailed to battens laid to float upon an isolating layer of mineral fibre capable of retaining its resilience under imposed loading. With battens running along the joists, a dense fibre layer can be used in strips. The ceiling below to be of metal lath and plaster not less than 29 mm thick, with pugging on the ceiling such that the combined mass per unit area of the floor, ceiling and pugging is not less than 120 kg/m ² . This construction will only give values for $D_{nT,w}$ of 50 to 53 dB, and a value for $L'_{nT,w}$ of 75 dB
		d) A floor consisting of 18 mm tongued and grooved chipboard on 19 mm plasterboard laid on battens running parallel to the joists and supported on 25 mm thick mineral wool of about 90 kg/m ³ to 140 kg/m ³ density; 100 mm of fibre absorbent (as used for insulation in roof spaces) laid between the joists on top of the plasterboard ceiling ¹⁾
		e) A floor consisting of 18 mm tongued and grooved chipboard on 19 mm plasterboard floating on a 25 mm thick mineral wool layer of about 60 kg/m ³ to 80 kg/m ³ density; this on a 12.5 mm plywood platform; 100 mm of fibre absorbent laid between the joists on top of the plasterboard ceiling ¹⁾
ii)	$D_{nT,w} = 32$ to 36 $L'_{nT,w} = 80$ to 85	Timber joist floor consisting of 22 mm tongued and grooved floor boarding or equivalent fixed directly to floor joists. Ceiling of 12.5 mm plasterboard and skim with no floor covering
<p>NOTES</p> <p>1 Construction details and workmanship are important if the levels of sound insulation indicated are to be achieved.</p> <p>2 Where plasterboard is specified it is assumed that the surface mass will be at least 8.5 kg/m³ for 12.5 mm thick board, and at least 14.5 kg/m² for 19 mm thick board. If less dense plasterboard is used, the thickness should be increased.</p> <p>¹⁾ In these types of floor construction, the ceiling may be 19 mm plus 12.5 mm plasterboard. It is imperative that the resilient layer is not punctured by nails.</p>		

ANNEX G

(Clause 13.1)

BASIC DESIGN TECHNIQUES FOR NOISE CONTROL IN AIR CONDITIONING, HEATING AND MECHANICAL VENTILATION SYSTEM

G-1 When selecting fans and other related mechanical equipment and when designing air distribution systems to minimise the sound transmitted from different components to the occupied spaces that they serve, the following recommendations should be considered:

- a) Design the air distribution system to minimise flow resistance and turbulence. High flow resistance increases the required fan pressure, which results in higher noise being generated by the fan. Turbulence increases the flow noise generated by duct fittings and dampers in the air distribution system, especially at low frequencies.
- b) Select a fan to operate as near as possible to its rated peak efficiency when handling the required quantity of air and static pressure. Also, select a fan that generates the lowest possible noise but still meets the required design conditions for which it is selected. Using an oversized or undersized fan that does not operate at or near rated peak efficiency may result in substantially higher noise levels.
- c) Design duct connections at both the fan inlet and outlet for uniform and straight air flow. Failure to do this may result in severe turbulence at the fan inlet and outlet and in flow separation at the fan blades. Both of these may significantly increase the noise generated by the fan.
- d) Select duct silencers that do not significantly increase the required fan total static pressure.
- e) Place fan-powered mixing boxes associated with variable volume air distribution systems away from noise-sensitive areas.
- f) Minimise flow-generated noise by elbows or duct branch take-offs, whenever possible, by locating them at least four to five duct diameters from each other. For high velocity systems, it may be necessary to increase this distance to up to ten duct diameters in critical noise areas.
- g) Keep airflow velocity in the duct as low as possible (7.5 m/s or less) near critical noise areas by expanding the duct cross-section area. However, do not exceed an included expansion angle of greater than 15°. Flow separation, resulting from expansion angles greater than 15°, may produce rumble noise. Expanding the duct cross-section area will reduce potential flow noise associated with turbulence in these areas.
- h) Use turning vanes in large 90° rectangular elbows and branch takeoffs. This provides a smoother transmission in which the air can change flow direction, thus reducing turbulence.
- j) Place grilles, diffusers and registers into occupied spaces as far as possible from elbows and branch takeoffs.
- k) Minimise the use of volume dampers near grilles, diffusers and registers in acoustically critical situations.
- m) Vibration isolates all vibrating reciprocating and rotating equipment if mechanical equipment is located on upper floors or is roof-mounted. Also, it is usually necessary to vibration isolate the mechanical equipment that is located in the basement of a building as well as piping supported from the ceiling slab of a basement, directly below tenant space. It may be necessary to use flexible piping connectors and flexible electrical conduit between rotating or reciprocating equipment and pipes and ducts that are connected to the equipment.
- n) Vibration isolates ducts and pipes, using spring and/or neoprene hangers for at least the first 15m from the vibration-isolated equipment.
- p) Use barriers near outdoor equipment when noise associated with the equipment will disturb adjacent properties if barriers are not used. In normal practice, barriers typically produce no more than 15 dB of sound attenuation in the mid-frequency range.
- q) Table 17 lists several common sound sources associated with mechanical equipment noise. Anticipated sound transmission paths and recommended noise reduction methods are also listed in the Table 18. Airborne and/or structure-borne sound can follow any or all of the transmission paths associated with a specified sound source.

Table 17 Sound Sources, Transmission Paths and Recommended Noise Reduction Methods

[Clause G-1(q)]

SI No.	Sound Source	Path No. (see Table 18)
(1)	(2)	(3)
i)	Circulating fans, grilles, registers, diffusers, unitary equipment in room	1
ii)	Induction coil and fan-powered VAV mixing units	1, 2
iii)	Unitary equipment located outside of room served; remotely located air handling equipment, such as fans, blowers, dampers, duct fitting, and air washers	2, 3
iv)	Compressors, pumps, and other reciprocating and rotating equipment (excluding air handling equipment)	4, 5, 6
v)	Cooling towers; air-cooled condensers	4, 5, 6, 7
vi)	Exhaust fans; window air conditioners	7, 8
vii)	Sound transmission between rooms	9, 10

Table 18 Sound Transmission Paths and Recommended Noise Reduction Methods

[Clause G-1(q) and Table 17]

SI No.	Path No.	Transmission Paths	Noise Reduction Methods
(1)	(2)	(3)	(4)
i)	1	Direct sound radiated from sound sources to ear Reflected sound from walls, ceiling and floor	Direct sound can be controlled only by selecting quiet equipment Reflected sound is controlled by adding sound absorption to the room and to equipment location
ii)	2	Air and structure-borne sound radiated from casings and through walls of ducts and plenums is transmitted through walls and ceiling into rooms	Design duct and fittings for low turbulence; locate high velocity ducts in noncritical areas; isolate ducts and sound plenums from structure with neoprene or spring hangers
iii)	3	Airborne sound radiated through supply and return air ducts to diffusers in room and then to listener by Path 1	Select fans for minimum sound power; use ducts lined with sound-absorbing material; use duct silencers or sound plenums in supply and return air ducts
iv)	4	Noise transmitted through equipment room walls and floors to adjacent rooms	Locate equipment rooms away from critical areas; use masonry blocks or concrete for equipment room walls and floor
v)	5	Vibration transmitted <i>via</i> building structure to adjacent walls and ceilings, from which it radiates as noise into room by Path 1	Mount all machines on properly designed vibration isolators; design mechanical equipment room for dynamic loads; balance rotating and reciprocating equipment
vi)	6	Vibration transmission along pipes and duct walls	Isolate pipe and ducts from structure with neoprene or spring hangers; install flexible connectors between pipes, ducts, and vibrating machines
vii)	7	Noise radiated to outside enters room windows	Locate equipment away from critical areas; use barriers and covers to interrupt noise paths; select quiet equipment
vii)	8	Inside noise follows Path 1	Select quiet equipment
ix)	9	Noise transmitted to an air diffusers in a room, into a duct, and out through an air diffuser in another room	Design and install duct attenuation to match transmission loss of wall between rooms
x)	10	Sound transmission through, over, and around room partition	Extend partition to ceiling slab and tightly seal all around; seal all pipe, conduit, duct and other partition penetrations

ANNEX H

(Clause 13.2)

SUGGESTED EQUIPMENT NOISE DATA SHEET

H-1 It is recommended that an equipment noise data sheet be furnished to intending bidders of mechanical equipment such as air conditioning, heating and mechanical ventilation machinery or diesel generating

units specifying noise requirements at the time of request for quotation. Following is a sample noise data sheet suggested for the purpose:

**SAMPLE OF EQUIPMENT NOISE DATA SHEET FOR NOISE
SPECIFICATION TO BE SENT TO SUPPLIERS**

Equipment Description _____ Type _____ Item No. _____

Octave-Band Centre Frequency Hz (1)	Desired Sound Pressure Level L_p (2)	Supplier to Complete		
		Actual (3)	Special Design (4)	Special Noise Control Measures Recommended (5)
63				
125				
250				
500				
1 000				
2 000				
4 000				
8 000				

NOTES

- 1 The measurements of SPL shall be at a distance of 1.0 m from the equipment and 1.5 m above grade or floor. The measurement method shall be described and the point of maximum levels furnished.
- 2 Complete column 3 for actual levels of standard equipment.
- 3 Complete column 4 for special design for low noise (if such alternative is available).
- 4 Complete column 5 for noise control measures such as enclosure.
- 5 Indicate if the equipment meets the specified noise levels without modification (Yes/No).
- 6 If no, additional costs required :
For Column 4 _____
For Column 5 _____

It will be observed from the cols 3, 4 and 5 that the buyer would get quotation for supply of standard equipment at a price P-1, whose noise characteristics would be as per col 3. Column 4 would indicate acoustical performance for a special design at a price

P-2. Column 5 would indicate the acoustical performance if the owners were to provide special noise control measures for the installation (whose broad details and approximate estimated cost is also furnished by the vendor).

LIST OF STANDARDS

The following list records those standards which are acceptable as 'good practice' and 'accepted standards' in the fulfilment of the requirements of the Code. The latest version of a standard shall be adopted at the time of enforcement of the Code. The standards listed may be used by the Authority for conformance with the requirements of the referred clauses in this Code. In the following list, the number appearing in the first column within parantheses indicates the number of the reference in this Section.

	<i>IS No.</i>	<i>Title</i>
(1)	11050 (Part 1) : 1984	Rating of sound insulation in buildings and of building elements : Part 1 Airborne sound insulation in buildings and of interior building elements
	(2) 4954 : 1968	Recommendations for noise abatement in town planning
	(3) 2526 : 1963	Code of practice for acoustical design of auditoriums and conference halls
	(4) 11050 (Part 1) : 1984	Rating of sound insulation in buildings and of building elements : Part 1 Airborne sound insulation in buildings and of interior building elements
	11050 (Part 2) : 1984	Rating of sound insulation in buildings and of building elements : Part 2 Impact sound insulation

NATIONAL BUILDING CODE OF INDIA

PART 8 BUILDING SERVICES

Section 5 Installation of Lifts, Escalators and Moving Walks:

5A Lifts

BUREAU OF INDIAN STANDARDS

CONTENTS

FOREWORD	... 3
1 SCOPE	... 5
2 TERMINOLOGY	... 5
3 GENERAL	... 10
4 PLANNING AND DESIGN GUIDELINES	... 12
5 LIFT ARRANGEMENTS AND PLANNING DIMENSIONS	... 20
6 CIVIL AND ELECTRICAL REQUIREMENTS FOR LIFTS	... 25
7 FIRE PROTECTION REQUIREMENTS FOR LIFTS	... 48
8 MINIMUM TECHNICAL AND SAFETY REQUIREMENTS	... 52
9 SPECIAL TECHNICAL REQUIREMENTS	... 61
10 PERFORMANCE REQUIREMENTS FOR LIFTS	... 69
11 SPECIAL TECHNICAL REQUIREMENTS FOR SUPER HIGH RISE BUILDINGS	... 69
12 LIFT ENQUIRY OR INVITATION TO TENDER	... 71
13 ACCEPTANCE OF TENDER AND SUBSEQUENT PROCEDURE	... 72
14 COORDINATION OF SITE WORK	... 73
15 INSPECTION AND ACCEPTANCE PROCEDURE FOR LIFTS	... 75
16 MAINTENANCE OF LIFTS	... 76
ANNEX A TYPICAL CHECKLIST OF VISUAL AND FUNCTIONAL CHECKS INVOLVED IN THE INSTALLATION OF LIFTS	... 82
ANNEX B TYPICAL EXAMPLES OF CHECKS TO BE TAKEN INTO ACCOUNT IN MAINTENANCE INSTRUCTIONS	... 91
ANNEX C EXAMPLES OF ELEMENTS TO BE TAKEN INTO ACCOUNT IN ANY RISK ASSESSMENT FOR MAINTENANCE OPERATIONS	... 95
LIST OF STANDARDS	... 96

National Building Code Sectional Committee, CED 46

FOREWORD

This Code (Part 8/Subsection 5A) deals with the installation requirements for planning, design, installation, operation, maintenance and inspection of lifts (passenger lifts, goods lifts, hospital lifts, service lifts and dumb waiter) so as to ensure safe movement of people with satisfactory performance.

This Section was first published in 1970 and was subsequently revised in 1983 and 2005. This Section covers the requirements for installation and maintenance of lifts and escalators in buildings. This Section shall be read with Part 4 'Fire and Life Safety' of the Code from fire safety requirements point of view. The major changes in the first revision of 1983 were addition of outline dimensions of different types of lifts and requirements of escalators in buildings. Emphasis was laid on coordination between the engineer/architect and the lift manufacturer to arrive at the number and position of lifts for attaining optimum efficiency in serving the building with safety.

The significant changes incorporated in the last revision in 2005 included addition of new clauses/recommendations on Building Management System; addition of new clauses on fireman's lift, infrared light curtain safety and Braille button for blind people and updation of provisions as per the revised standards on lifts on which this section was based.

As a result of experience gained since implementation of 2005 version of the Code and feedback received as well as revisions of Indian Standards on which this Section was based, a need was felt to revise this Section. In this revision, the erstwhile Section 5 on Lifts and Escalators has been divided into two subsections namely:

5A Installation of Lifts

5B Installation of Escalators and Moving Walks

This revision has, therefore, been formulated to take care of these. The significant changes incorporated in this revision (Subsection 5A) include the following:

- a) Definitions of a number of terms relating to performance measurement of lifts, and seismic and maintenance aspects of lifts have been included, apart from other modifications in the terminology clause.
- b) Requirements for high speed lifts and lifts for tall buildings including elaboration of lifts for fire-fighting and emergency evacuation have been included.
- c) Considerations for machine room less (MRL) lifts have been covered.
- d) The clause on preliminary design has been expanded to cover the requirements for various building functions.
- e) Provisions related to destination control system have been included.
- f) Various special requirements have been detailed in a separate clause.
- g) Provisions for seismic resistance aspects in lifts have been included.
- h) Performance measurements for lifts have been included.
- j) A new clause on operation and maintenance of lifts has been included.
- k) The provisions have been updated as per the revised Indian Standards on lifts on which this Subsection is based.
- m) The list of Indian Standards as good practices/accepted standards has been updated.

The information contained in this Section is largely based on the following Indian Standards:

<i>IS No.</i>	<i>Title</i>
14665	Electric Traction Lifts
(Part 1) : 2000	Guidelines for outline dimensions of passenger, goods, service and hospital lifts
(Part 2/Sections 1 and 2 : 2000	Code of practice for installation, operation and maintenance, Section 1 Passenger and goods lifts, Section 2 Service lifts

<i>IS No.</i>	<i>Title</i>
(Part 3/Sections 1 and 2) : 2000	Safety rules, Section 1 Passenger and goods lifts, Section 2 Service lifts
(Part 4/ Sections 1 to 9) : 2001	Components, Section 1 Lift buffers, Section 2 Lift guide rails and guide shoes, Section 3 Lift carframe, car, counterweight and suspension, Section 4 Lift safety gears and governors, Section 5 Lift retiring cam, Section 6 Lift doors and locking devices and contacts, Section 7 Lift machines and brakes, Section 8 Lift wire ropes, Section 9 Controller and operating devices
(Part 5 : 1999)	Inspection manual
IS 14671 : 1999	Code of Practice for installation and maintenance of hydraulic lifts
IS 15330 : 2003	Code of Practice for installation and maintenance of lifts for handicapped persons
IS 15785 : 2007	Code of Practice for installation and maintenance of lift without conventional machine rooms

Assistance has also been derived from the following publications for the formulation of this Subsection:

EN 81-20 : 2014	Safety rules for the construction and installation of lifts — Lifts for the transport of persons and goods — Part 20: Passenger and goods passenger lifts
EN 81-77 : 2013	Safety rules for the construction and installations of lifts. Particular applications for passenger and goods passenger lifts. Lifts subject to seismic conditions
EN 81-50 : 2014	Safety rules for the construction and installation of lifts — Examinations and tests — Part 50: Design rules, calculations, examinations and tests of lift components
ISO 18738-1 : 2012	Measurement of ride quality — Part 1: Lifts (elevators)
ISO 7465 : 2007	Passenger lifts and service lifts — Guide rails for lift cars and counterweights — T-type
ISO/TS 18870 : 2014	Lifts (elevators) — Requirements for lifts used to assist in building evacuation
ISO 3008-2 : 2014	Fire-resistance tests — Part 2: Lift landing door assemblies
ISO 3864-1 : 2011	Graphical symbols — Safety colours and safety signs — Part 1: Design principles for safety signs and safety markings
ISO 4190-1 : 2010	Lift (Elevator) installation — Part 1: Class I, II, III and VI lifts
ISO 4190-5 : 2006	Lift (Elevator) installation — Part 5: Control devices, signals and additional fittings
CIBSE Guide D: 2015	Transportation Systems in Buildings 2015, The Chartered Institution of Building Services Engineers, London, U.K.
CTBUH 2004	Emergency Evacuation: Elevator Systems Guidelines, Council on Tall Buildings and Urban Habitat, Illinois, USA

All standards, whether given herein above or cross-referred to in the main text of this Subsection, are subject to revision. The parties to agreement based on this Subsection are encouraged to investigate the possibility of applying the most recent editions of the standards.

For the purpose of deciding whether a particular requirement of this Subsection is complied with, the final value, observed or calculated, expressing the result of a test or analysis, shall be rounded off in accordance with IS 2 : 1960 'Rules for rounding off numerical values (*revised*)'. The number of significant places retained in the rounded off value should be the same as that of the specified value in this Subsection.

NATIONAL BUILDING CODE OF INDIA

PART 8 BUILDING SERVICES

Section 5 Installation of Lifts, Escalators and Moving Walks: 5A Lifts

1 SCOPE

1.1 This Code (Part 8/Subsection 5A) covers the requirements for planning, design, installation, operation, maintenance and inspection of lifts (passenger lifts, goods lifts, hospital lifts, service lifts and dumb waiter) so as to ensure safe movement of people with satisfactory performance.

1.2 This Subsection gives information that should be exchanged among the architect/engineer, the consulting engineer and the lift manufacturer from the stage of planning to installation including maintenance.

NOTE — The provisions given in this Subsection are primarily for electric traction lifts; however, most of these provisions are also applicable to hydraulic lifts {see good practice [8-5A(1)]}.

2 TERMINOLOGY

For the purpose of this subsection, the following definitions shall apply.

2.1 General Terms Relating to Lifts

2.1.1 Automatic Rescue Device (ARD) — A device meant to bring a lift stuck between floors due to loss of power, to the nearest landing level in either direction and open the doors in order to allow trapped passengers to be evacuated. Such a device may use some form of internal auxiliary power source for such purpose, complying with all the safety requirements of the lift during normal run. The speed of travel is usually lower than the normal speed. On reaching the level, in case of manual door lifts, the device shall allow the door to be opened and in case of power operated door lifts the device shall automatically open the door.

2.1.2 Bottom Car Run-by — The distance between the car buffer striker plate and the striking surface of the car buffer when the car is in level with the bottom terminal landing.

2.1.3 Bottom Counterweight Run-by — The distance between the counter weight buffer striker plate and the striking surface of the counterweight buffer when the car is in level with the top terminal landing.

2.1.4 Buffer — A device designed to stop a descending car or counter weight beyond its normal limit of travel by storing or by absorbing and dissipating the kinetic energy of the car or counterweight.

2.1.4.1 Oil buffer — A buffer using oil as a medium which absorbs and dissipates the kinetic energy of the descending car or counterweight.

2.1.4.1.1 Oil buffer stroke — The oil displacing movement of the buffer plunger or piston, excluding the travel of the buffer plunger accelerating device.

2.1.4.2 Spring buffer — A buffer which stores in a spring the kinetic energy of the descending car or counterweight.

2.1.4.2.1 Spring buffer load rating — The load required to compress the spring by an amount equal to its stroke.

2.1.4.2.2 Spring buffer stroke — The distance, the contact end of the spring can move under a compressive load until the spring is compressed solid.

2.1.5 Call Indicator — A visual and audible device in the car to indicate to the attendant the lift landings from which calls have been made.

2.1.6 Car Bodywork — The enclosing bodywork of the lift car which comprises the sides and roof and is built upon the car platform.

2.1.7 Car Door Electric Contact — An electric device, the function of which is to prevent operation of the driving machine by the normal operating device of the lift unless the car door is in the closed position.

2.1.8 Car Frame — The supporting frame or sling to which the platform of the lift car, its safety gear, guide shoes and suspension ropes are attached.

2.1.9 Car Platform — The part of the lift car which forms the floor and directly supports the load.

2.1.10 Clearance

2.1.10.1 Bottom car clearance — The clear vertical distance from the pit floor to the lowest structural or mechanical part, equipment or device installed beneath the car platform, except the guide shoes, rollers, safety jaw blocks and platform apron or guard located within 300 mm, measured horizontally from the sides of the car platform when the car rests on its fully compressed buffers.

2.1.10.2 Top car clearance — The shortest vertical distance between the top of the car crosshead, or between the top of the car where no crosshead is

provided, and the nearest part of the overhead structure or any other obstruction when the car floor is level with the top terminal landing.

2.1.10.3 Top counterweight clearance — The shortest vertical distance between any part of the counterweight structure and the nearest part of the overhead structure or any other obstruction when the car floor is level with the bottom terminal landing.

2.1.11 Control — The system governing starting, stopping, direction of motion, acceleration, speed and retardation of moving member.

2.1.11.1 Single-speed alternating current control — A control for a driving machine induction motor which is arranged to run at a single-speed.

2.1.11.2 Two-speed alternating current control — A control for a two-speed driving machine induction motor which is arranged to run at two different synchronous speeds either by pole changing of a single motor or by two different armatures.

2.1.11.3 Rheostatic control — A system of control which is accomplished by varying resistance or reactance or both in the armature or field circuit or both of the driving machine motor.

2.1.11.4 Variable voltage motor control (generator field control) — A system of control which is accomplished by the use of an individual generator for each lift wherein the voltage applied to the driving machine motor is adjusted by varying the strength and direction of the generator field.

2.1.11.5 Electronic devices — A system of control which is accomplished by the use of electronic devices for driving the lift motor at variable speed.

2.1.11.6 Alternating current variable voltage (ACVV) control — A system of speed control which is accomplished by varying the driving and braking torque by way of voltage variation of the power supply to the driving machine induction motor.

2.1.11.7 Alternating current variable voltage variable frequency (ACVVVF) control — A system of speed control which is accomplished by varying the voltage and frequency of the power supply to the driving machine induction motor.

2.1.11.8 Solid-state d.c. variable voltage control — A solid-state system of speed control which is accomplished by varying the voltage and direction of the power supply to the armature of driving machine d.c. motor.

2.1.12 Counterweight — A weight or series of weights to counterbalance the weight of the lift car and part of the rated load.

2.1.13 Deflector Sheave — An idler pulley used to change the direction of a rope lead.

2.1.14 Door (Lift Landing Door and Lift Car Door)

2.1.14.1 Door, centre opening sliding — A door which slides horizontally and consists of two or more panels which open from the centre and are usually so interconnected that they move simultaneously.

2.1.14.2 Door, mid-bar collapsible — A collapsible door with vertical bars mounted between the normal vertical members.

2.1.14.3 Door, multi-panel — A door arrangement whereby more than one panel is used such that the panels are connected together and can slide over one another by which means the clear opening can be maximized for a given shaft width. Multipanels are used in centre opening and two speed sliding doors.

2.1.14.4 Door, single slide — A single panel door which slides horizontally.

2.1.14.5 Door, two speed sliding — A door which slides horizontally and consists of two or more panels, one of which moves at twice the speed of the other.

2.1.14.6 Door, vertical bi-parting — A door which slides vertically and consists of two panels or sets of panels that move away from each other to open and are so interconnected that they move simultaneously.

2.1.14.7 Door, vertical lifting — A single panel door, which slides in the same plane vertically up to open.

2.1.14.8 Door, swing — A swinging type single panel door which is opened manually and closed by means of a door closer when released.

2.1.15 Door Closer — A device which automatically closes a manually opened door.

2.1.16 Door Operator — A power-operated device for opening and closing doors.

2.1.17 Dumb Waiter — A lift with a car which moves in guides in a vertical direction; has a net floor area not exceeding 1 m², total inside height of 1.2 m, whether or not provided with fixed or removable shelves; has a capacity not exceeding 250 kg and is exclusively used for carrying materials and shall not carry any person.

2.1.18 Electrical and Mechanical Interlock — A device provided to prevent simultaneous operation of both up and down relays or power contactors.

2.1.19 Electro-Mechanical Lock — A device which combines in one unit, electrical contact and a mechanical lock jointly used for the landing and/or car doors.

2.1.20 Floor Levelling Switch — A switch for bringing

the car to level at slow speed in case of double speed or variable speed machines.

2.1.21 Floor Selector — A mechanism forming a part of the control equipment, in certain automatic lifts, designed to operate controls which cause the lift car to stop at the required landings.

2.1.22 Floor Stopping Switch — A switch or combination of switches arranged to bring the car to rest automatically at or near any pre-selected landing.

2.1.23 Geared Machine — A machine in which the power is transmitted to the sheave through worm and worm wheel or spur reduction gearing.

2.1.24 Gearless Machine — A lift machine in which the motive power is transmitted to the driving sheave from the motor without intermediate reduction gearing and has the brake drum mounted directly on the motor shaft.

2.1.25 Goods Lift — A lift designed primarily for the transport of goods, but which may carry a lift attendant or other personnel necessary for the loading or unloading of goods.

2.1.26 Guide Rails — The members used to guide the movement of a lift car or counterweight in a vertical direction.

2.1.27 Guide Rails Fixing — The complete assembly comprising the guide rails bracket and its fastenings.

2.1.28 Guide Shoe — An attachment to the car frame or counterweight for the purpose of guiding the lift car or counter weight frame.

2.1.29 Hoisting Beam — A beam, mounted immediately below the machine room ceiling/machinery space ceiling, to which lifting tackle can be fixed for raising or lowering parts of the lift machine.

2.1.30 Hospital Lift — A lift normally installed in a hospital, dispensary or clinic and designed to accommodate one bed or stretcher along its depth, with sufficient space around to carry a minimum of three attendants in addition to the lift operator.

2.1.31 Landing Call Push — A push button fitted at a lift landing, either for calling the lift car, or for actuating the call indicator.

2.1.32 Landing Door — The hinged or sliding portion of a lift well enclosure, controlling access to a lift car at a lift landing.

2.1.33 Landing Zone — A space extending from a horizontal plane 400 mm below a landing level to a plane 400 mm above the landing level.

2.1.34 Levelling Devices

2.1.34.1 Levelling device, lift car — Any mechanism

which either automatically or under the control of the operator, moves the car within the levelling zone towards the landing only, and automatically stops it at the landing.

2.1.34.2 Levelling device, one way automatic — A device which corrects the car level only in case of under run of the car but will not maintain the level during loading and unloading.

2.1.34.3 Levelling device, two-way automatic maintaining — A device which corrects the car level on both under run and over-run and maintains the level during loading and unloading.

2.1.34.4 Levelling device, two way automatic non-maintaining — A device which corrects the car level on both under run and over run but will not maintain the level during loading and unloading.

2.1.35 Levelling Zone — The limited distance above or below a lift landing within which the levelling device may cause movement of the car towards the landing.

2.1.36 Lift — An appliance designed to transport persons or materials between two or more levels in a vertical or substantially vertical direction by means of a guided car. The word 'elevator' is also synonymously used for 'lift'.

2.1.37 Lift Car — The load carrying unit with its floor or platform, enclosing bodywork, and car door.

2.1.38 Lift Landing — That portion of a building or structure used for discharge of passengers or goods or both into or from a lift car.

2.1.39 Lift Machine — The part of the lift equipment comprising the motor and the control gear therewith, reduction gear (if any), brake(s) and winding drum or sheave, by which the lift car is raised or lowered.

2.1.40 Lift Pit — The space in the lift well below the level of the lowest lift landing served.

2.1.41 Lift Well — The unobstructed space within an enclosure provided for the vertical movement of the lift car(s) and any counterweight(s), including the lift pit and the space for top clearance.

2.1.42 Lift Well Enclosure — Any structure which separates the lift well from its surroundings.

2.1.43 Operation — The method of actuating the control of lift machine.

2.1.43.1 Automatic operation — A method of operation in which by a momentary activation of a call button the lift car is set in motion and caused to stop automatically at any required lift landing.

2.1.43.2 Non-selective collective automatic operation — Automatic operation by means of one

button in the car for each landing level served and one button at each landing, wherein all stops registered by the momentary actuation of landing or car buttons are made irrespective of the number of buttons actuated or of the sequence in which the buttons are actuated. With this type of operation, the car stops at all landings for which buttons have been actuated making the stops in the order in which the landings are reached after the buttons have been actuated but irrespective of its direction of travel.

2.1.43.3 Selective collective automatic operation — Automatic operation by means of one button in the car for each landing level served and by up and down buttons at the landings, wherein all stops registered by the momentary actuation of the car made as defined under non-selective collective automatic operation, but wherein the stops registered by the momentary actuation of the landing buttons are made in the order in which the landings are reached in each direction of travel after the buttons have been actuated. With this type of operation, all ‘up’ landing calls are answered when the car is travelling in the up direction and all ‘down’ landing calls are answered when the car is travelling in the down direction, except in the case of the uppermost or lowermost calls which are answered as soon as they are reached irrespective of the direction of travel of the car.

2.1.43.4 Single automatic operation — Automatic operation by means of one button in the car for each landing level served and one button at each landing so arranged that if any car or landing button has been actuated, the actuation of any other car or landing operation button will have no effect on the movement of the car until the response to the first button has been completed.

2.1.43.5 Group automatic operation — Automatic operation of two or more non-attendant lifts equipped with power-operated car and landing doors. The operation of the cars is coordinated by a supervisory operation system including automatic dispatching means whereby selected cars at designated dispatching points automatically close their doors and proceed on their trips in a regulated manner.

Typically, it includes one button in each car for each floor served and up and down buttons at each landing (single buttons at terminal landings). The stops set up by the momentary actuation of the car buttons are made automatically in succession as a car reaches the corresponding landings irrespective of its direction of travel or the sequence in which the buttons are actuated. The stops set up by the momentary actuation of the landing buttons may be accomplished by any lift in the group, and are made automatically by the first available car that approaches the landing in the corresponding direction.

2.1.43.6 Car switch operation — Method of operation by which the movement of lift car is directly under the operation of the attendant by means of a handle.

2.1.43.7 Signal operation — Same as collective operation, except that the closing of the door is initiated by the attendant.

2.1.43.8 Double button (continuous pressure) operation — Operation by means of buttons or switches in the car and at the landings any of which may be used to control the movement of the car as long as the button or switch is manually pressed in the actuating position.

2.1.44 Operating Device — A car switch, push button or other device employed to actuate the control.

2.1.45 Overhead Beams — The members, usually of steel, which immediately support the lift equipment at the top of the lift well.

2.1.46 Over Speed Governor — An automatic device which brings the lift car and/or counter weight to rest by operating the safety gear in the event of the speed in a descending direction exceeding a predetermined limit.

2.1.47 Passenger Lift — A lift designed for the transport of passengers.

2.1.48 Position and/or Direction Indicator — A device which indicates on the lift landing or in the lift car or both, the position of the car in the lift well or the direction in which the lift car is travelling or both.

2.1.49 Rated Load (Lift) — The maximum load for which the lift car is designed and installed to carry safely at its rated speed.

2.1.50 Rated Speed (Lift) — The mean of the maximum speed attained by the lift car in the upward and downward direction with rated load in the lift car.

2.1.51 Retiring Cam — A device which prevents the landing doors from being unlocked by the lift car unless it stops at a landing.

2.1.52 Roping Multiple — A system of roping where, in order to obtain a multiplying factor from the machine to the car, multiple falls of rope are run around sheave on the car or counterweight or both. It includes roping arrangement of 2 to 1, 3 to 1, etc.

2.1.53 Safety Gear — A mechanical device attached to the lift car or counterweight or both, designed to stop and to hold the car or counterweight to the guides in the event of free fall, or, if governor operated, of over-speed in the descending direction. Any anticipated impact force shall be added in the general drawing or layout drawing.

2.1.54 Service Lift — A passenger cum goods lift meant to carry goods along with people.

NOTE — Typically in an office building this may be required to carry food or stationeries, in a residential building to carry luggage or accommodate a stretcher and in a hotel to be used for food trolleys or baggage. There is a need in such lifts, to take care of the dimensions of the car and the door clear opening in line with the type of goods that may have to be carried based on mutual discussion between the supplier and the customer. Also, such lifts shall have buffer railings in the car at suitable height to prevent damage to the car panels when the goods are transported. Typically such lifts, if provided with an automatic door, may use some means to detect trolleys and stretcher movement in advance to protect the doors against damage. The car floor load calculations and car area of such a lift is as in the case of a passenger lift except that these are not meant to carry heavy concentrated loads.

2.1.55 Sheave — A rope wheel, the rim of which is grooved to receive the suspension ropes but to which the ropes are not rigidly attached and by means of which power is transmitted from the lift machine to the suspension ropes.

2.1.56 Slack Rope Switch — Switch provided to open the control circuit in case of slackening of rope(s).

2.1.57 Suspension Ropes — The ropes by which the car and counter weight are suspended.

2.1.58 Terminal Slow-Down Switch — A switch when actuated shall compulsorily cut off the high speed and switch on the circuitry to run the lift in levelling speed before reaching on terminal landings.

2.1.59 Terminal Stopping Switch Normal — Switch for cutting off all the energizing current in case of car travelling beyond the top or bottom terminal landing or a switch that cuts off the energizing current so as to bring the car to a stop at the top or bottom terminal landing level in the respective direction of travel.

2.1.60 Terminal Stopping Device Final — A device which automatically causes the power to be removed from an electric lift driving machine motor and brake, independent of the functioning of the normal terminal stopping device, the operating device or any emergency terminal stopping device, after the car has passed a terminal landing.

2.1.61 Total Headroom — The vertical distance from the level of the top lift landing to the bottom of the machine room slab.

2.1.62 Travel — The vertical distance between the bottommost and topmost lift landings served by the lift.

2.2 Terms Relating to Performance Requirements for Lifts

2.2.1 A95 — Values of acceleration or vibration within defined boundaries or limits, in which 95 percent of observed values fall. This value is used statistically to estimate typical levels.

2.2.2 Acceleration — Rate of change of z-axis velocity, attributed to lift motion control.

2.2.3 Axis of Measurement — Orthogonal reference axes for the measurements as follows:

- X-axis* — Axis perpendicular to the plane of the car front door (that is back to front),
- Y-axis* — Axis perpendicular to X and Z (that is side to side), and
- Z-axis* — Axis perpendicular to the car floor (that is vertical).

2.2.4 Equivalent Sound Pressure Level (L_{Aeq}) — Average A-weighted sound pressure level, using frequency weighting A and time weighting 'fast', determined within defined boundaries.

2.2.5 Jerk — Rate of change of z-axis acceleration, attributed to lift motion control. It is expressed in metre per second cube (m/s^3).

NOTE — The passenger perception of vertical ride quality during jerk is represented by the assessment of vertical vibration during non-constant acceleration.

2.2.6 Lift Ride Quality — Sound levels in the car, and vibration of the car floor, relevant to passenger perception, associated with lift motion.

2.2.7 Peak to Peak Vibration Levels — Sum of the magnitudes of two peaks of opposite sign separated by a single zero crossing.

2.2.8 Sound — A-weighted sound pressure level measured in decibels (dB).

2.2.9 Sound Pressure Level ($L_{p,A}$) — Ten times the logarithm to the base 10 of the ratio of the square of the sound pressure measured (p_A) to the square of the reference sound pressure (p_0).

$$L_{p,A} = 10 \log (p_A^2/p_0^2) \text{ dBA}$$

NOTE — The reference sound pressure level (p_0) is $20 \mu\text{Pa}$ ($2 \times 10^{-5} \text{ Pa}$). The measured sound pressure, p_A , is in Pascals, using frequency weighting A.

2.2.10 V95 — Value of velocity within defined boundaries or limits, in which 95 percent of observed values fall. This value is used statistically to estimate typical levels.

2.2.11 Velocity — Rate of change of z-axis displacement, attributed to lift motion control.

2.2.12 Vibration — Variation with time of the magnitude of acceleration, when the magnitude is alternately greater and smaller than a reference level. It is expressed in m/s^2 .

2.3 Terms Relating to Planning and Design of Lifts

2.3.1 Door Closing Time (t_c) — Time period measured from the instant that car doors start to close until the doors are locked.

2.3.2 Door Opening Time (t_o) — Time period measured from the instant that car doors start to open until they are open 800 mm.

2.3.3 Door-to-Door Time (T) — Time period measured from the instant that car doors start to close to the instant that the car doors are open 800 mm at the next adjacent floor.

2.3.4 Handling Capacity (HC) — The number of passengers that a lift system can theoretically transport during the up-peak traffic condition with car occupancy of 80 percent of the actual capacity expressed as a percent of the total building population.

2.3.5 Interval (INT) — Time period between successive car arrivals at the main terminal floor with cars loaded to any value.

2.3.6 Nominal Travel Time (NTT) — The nominal travel time is defined as the time it would take to run a distance of the total travel at the rated speed of the lift without taking into account the acceleration and deceleration of the car or the intermediate stops of real runs.

2.3.7 Passenger Arrival Rate — Percentage of a building's population arriving within a 5 min period.

2.3.8 Passenger Average Transfer Time (t_p) — Average period of time required for a single passenger to enter or leave the lift car.

2.3.9 Passenger Average Waiting Time (AWT) — Average period of time from the instant a passenger registers a landing call or joins a queue, until the responding lift begins to open its doors at the boarding floor. AWT is not the same as INT .

2.3.10 Round Trip Time (RTT) — The average time taken by a single lift to make a trip from the main terminal back to the main terminal, starting from the time the car doors open at the main terminal until the car doors re-open at the main terminal after serving all demand along the way.

2.3.11 Single Floor Flight Time (t_{fl}) — Period of time measured from the instant that the car doors are locked until the lift is level at the next adjacent floor.

2.3.12 Single Floor Transit Time (t_v) — Period of time required to transit two adjacent floors at rated speed.

2.3.13 Sky Lobby — A sky lobby is the main floor for local groups in the upper part of a very tall building.

2.4 Terms Relating to Seismic Operation of Lifts

2.4.1 Design Acceleration (a_d) — The horizontal acceleration to be used for calculation of forces (moments acting on lift systems and arising from seismic events).

NOTE — The value of (a_d) shall be obtained by the lift manufacturer from the building engineer/structural engineer.

2.4.2 Normal Operation — Operation mode in which the lift performs when not in seismic mode or in seismic stand-by mode.

2.4.3 Retaining Device — Mechanical device securely fixed to a structural member of the lift car, counterweight frame designed to retain the lift car and counterweight within its guide rails during seismic activity.

2.4.4 Seismic Mode — Special mode in which the lift operates after detection of seismic trigger level.

2.4.5 Seismic Stand-By Mode — Special mode in which the lift operates after detection of primary earthquake wave without the activation of the seismic detection system.

2.4.6 Seismic Trigger Level — Seismic acceleration which is used to activate a seismic detection system.

2.4.7 Snag Point — The point of interference between flexible elements (for example, ropes, chains, travelling cable, etc) and fixed elements (for example, by guide rail brackets, guide rail clip bolts, fishplates, vanes, and similar devices).

2.5 Terms Related to Maintenance of Lifts

2.5.1 Competent Maintenance Person — Designated person, suitably trained, qualified by knowledge and practical experience, provided with necessary instructions and supported within their maintenance organization to enable the required maintenance operations to be safely carried out.

2.5.2 Installation — Completely installed passenger lift or good passenger lift or accessible goods only lift or service lift.

2.5.3 Installer — Natural or legal person who takes responsibility for the design, manufacture, installation and placing on the market of lifts.

2.5.4 Maintenance Organization — Company or part of company where competent maintenance person(s) carry out maintenance operation on behalf of the owner of the installation.

3 GENERAL

3.1 Conformity with Lifts Act and Rules

3.1.1 The installation shall generally be carried out in conformity with *Lift Acts and Rules*, wherever they are in force.

3.1.2 It is the responsibility of the owner of the premises where the lift will be installed, to obtain necessary permission from the Authority before and

after the installation of lifts and for subsequent operation of lifts.

3.1.3 A licence for public use is a safety provision, issued by state authorities under *Lifts Acts* and *rules* wherever they are in force, and shall be obtained as per the laid down statutory requirement.

3.2 Conformity with *The Electricity Act, 2003* and Rules/Regulations Thereunder

All electrical work in connection with installation of lifts shall be carried out in accordance with the provisions of *The Indian Electricity Act, 2003* as amended up-to-date along with the rules and regulations framed thereunder and shall also comply with the other provisions of Part 8 ‘Building Services, Section 2 Electrical and Allied Installations’ of the Code.

3.3 Conformity with Indian Standards

All materials, fittings, appliances, etc, used in electrical installation shall conform to Indian Standard specifications wherever these exist. In case of materials for which Indian Standard specifications do not exist, the materials shall be approved by the competent authority. For detailed specification for lifts, reference shall be made to accepted standards [8-5A(2)].

3.4 Conformity to Accessibility Requirements

All lifts installed for public use shall meet the accessibility requirements in accordance with 13 of Part 3 ‘Development Control Rules and General Building Requirements’ of the Code.

3.5 Conformity with Fire Regulations

The installation shall be carried out in conformity with Part 4 ‘Fire and Life Safety’ of the Code and the state fire acts/local fire regulations, wherever they are in force.

3.6 Considerations for Selection of Lifts

The considerations for selection of lifts shall be based on the following criteria:

- a) *Intended use of lift* — The number of lifts and their capacities (that is, load and speed) required for a given building shall be suitably decided to meet the intended requirement. The passenger lifts shall meet the requirements of handling capacity and waiting time for passenger, depending on the lift’s expected usage and building type.
- b) *System performance* — System performance criteria shall be based on building type

(residential, commercial, hotel, hospital, etc).

- c) *Accessibility requirements* — see 3.4.
- d) *Environmental conditions* — Lifts directly exposed to atmospheric conditions, that is, weather (for example, those meant for external applications), or any other adverse condition shall be appropriately designed and protected for that particular condition.
- e) *Type of main drive for lift* — Whether electric traction, geared or gearless or hydraulic depending on speed, stops/travel height and capacity requirement.
- f) *Civil engineering requirements* — Machinery location that is, machinery to be located in machine room or machinery to be kept inside lift well thereby eliminating conventional machine room.
- g) *Seismic considerations* — Whether the lift is to be protected against seismic forces or whether the lift is to be rescued to a landing on detection of earthquake or both.

3.7 Maintenance

The considerations relating to maintenance shall be as follows:

- a) The lift installation shall receive regular cleaning, lubrication, adjustment and adequate servicing by authorized competent persons at such intervals as per type of equipment and frequency of service demand. It is desirable and normal for the lift supplier to be entrusted with the servicing during the guarantee period of new lift.
- b) In order that the lift installation is maintained at all times in a safe condition, a proper maintenance schedule shall be drawn up in consultation with the lift manufacturer and rigidly followed. The provision of a log book to record all items relating to general servicing and inspection is recommended for all lifts.
- c) Any accident arising out of operation or maintenance of the lifts shall be duly reported to the authority in accordance with the rules laid down.
- d) Lifts are required by statutory regulations to be examined at regular intervals as specified by lift acts, by a competent person.
- e) The company entrusted with maintenance contract shall have valid licence to maintain the lifts. The persons assigned for maintenance work shall be appropriately qualified and experienced as required by *Lift Acts* and *Rules*.

3.8 Energy Efficiency and Sustainability

Design options like space restrictions, reliability and safety, riding comfort have been the major market and technological driver. The following should be encouraged for reducing power consumption and promoting sustainability in buildings.

- a) Energy efficient a.c. variable voltage variable frequency (VVVF) motor drive or equivalent. Lifts with 1-speed and 2-speed motor control are not recommended for passenger lifts because of high power consumption, poor passenger comfort and tripping hazard.
- b) When the lift has answered the last call and stopped at a landing and no further landing call is registered, the car and landing doors shall close. If there is no further landing call after pre-determined period but not less than 90 s, the light and fan inside the car shall both be automatically switched off. Car lights and fan shall switch on automatically before the lift doors start to open or the lift is set in motion.
- c) Under normal operating status, at least one lift car of a lift bank shall operate under a standby or sleep mode during off-peak period when the traffic demand on the vertical transportation system is low. During low demand periods, even completely shutting down one or more lifts within a group can be a good energy saving option, without compromising quality of service.
- d) Where a number of lifts are installed together, their controls are interconnected to optimize their operation. By efficiently delivering passengers with the least amount of trips, starts and stops, the energy consumed is significantly reduced.
- e) Energy saving LED lamps for car lighting in place of conventional lamps.
- f) Gearless type machines to reduce transmission losses.
- g) Improvement in total power factor of the motor drive of a lift at the isolator connecting lift to the building's electrical supply circuit.
- h) Regenerative drives to recycle energy rather than wasting it as heat. The regenerated energy may be used for charging batteries, staircase lighting, lobby lighting, etc.
- j) Use of high efficiency motors such as Permanent Magnet Synchronous Motors, or Induction motors having minimum efficiency class equivalent to IE2 as per accepted standard [8-5A(3)].

- k) Adoption of materials and practices that are environmentally friendly and sustainable shall be promoted.

4 PLANNING AND DESIGN GUIDELINES

4.1 The planning guidelines, design considerations, and precautions to be exercised during design of passenger and goods lifts operated by electric traction are provided hereunder. Manufacturer may be consulted for other types of lifts such as hydraulic, home, automobile lifts, etc.

Design of lifts necessarily calls for coordination among various parties concerned, namely the client, the architect/engineer, the consulting engineers and the lift manufacturer. These guidelines give the information from the stage of planning till the design that should be exchanged between parties. It is essential that all the parties involved in the planning should have a clear understanding of the basis and the theory of planning. All parties involved need to recognize that it is highly impractical to correct badly planned lifts in a building as no changes can be carried out to the building core, if the number of hoist-ways is inadequate or of wrong size or wrongly positioned.

These provisions specify requirements for the architects/engineers, builders/ developers and tenderers while finalizing specification of lifts. Two basic considerations, namely, the quantity of service required and the quality of service desired, determine the number and type of lifts to be provided in a particular building. The quantity of service factor, that is, how many people might use the lift system over a defined period of time is represented by the handling capacity. The quality of service factor, that is, how well the lift system deals with its passengers is represented by passenger waiting time and lobby queuing. These factors are interrelated and depend, among other things, on the type of building and its use and on the type of occupier. Both these factors require proper study into the character of the building, extent and duration of peak periods, frequency of service required, type and method of control, type of landing doors, etc.

Figure 1 shows the flow chart to arrive at a reasonable vertical transportation solution for a building.

The adequacy of the lift group in a building is a major contributing factor to the success or failure of a building. Users of lifts would be intolerant of long queues and long waiting times. The planning and selection of the vertical transportation equipment is a specialized activity. Although the basic calculations are relatively simple, the theory on which they are based is complex. The difficulty in planning a lift installation is not only in calculating its probable performance but

also in estimating the passenger demand and usage patterns. The architect/engineer doing the planning work should establish the lift system at a very early stage in consultation with the lift manufacturer/consulting engineer and not after the rest of the building has been designed.

This Subsection defines the calculation approach for conventional two button dispatching and does not define calculation methods for destination control systems or hybrid systems. It also does not define an approach to simulation methods as consensus on how to apply simulation has not been established.

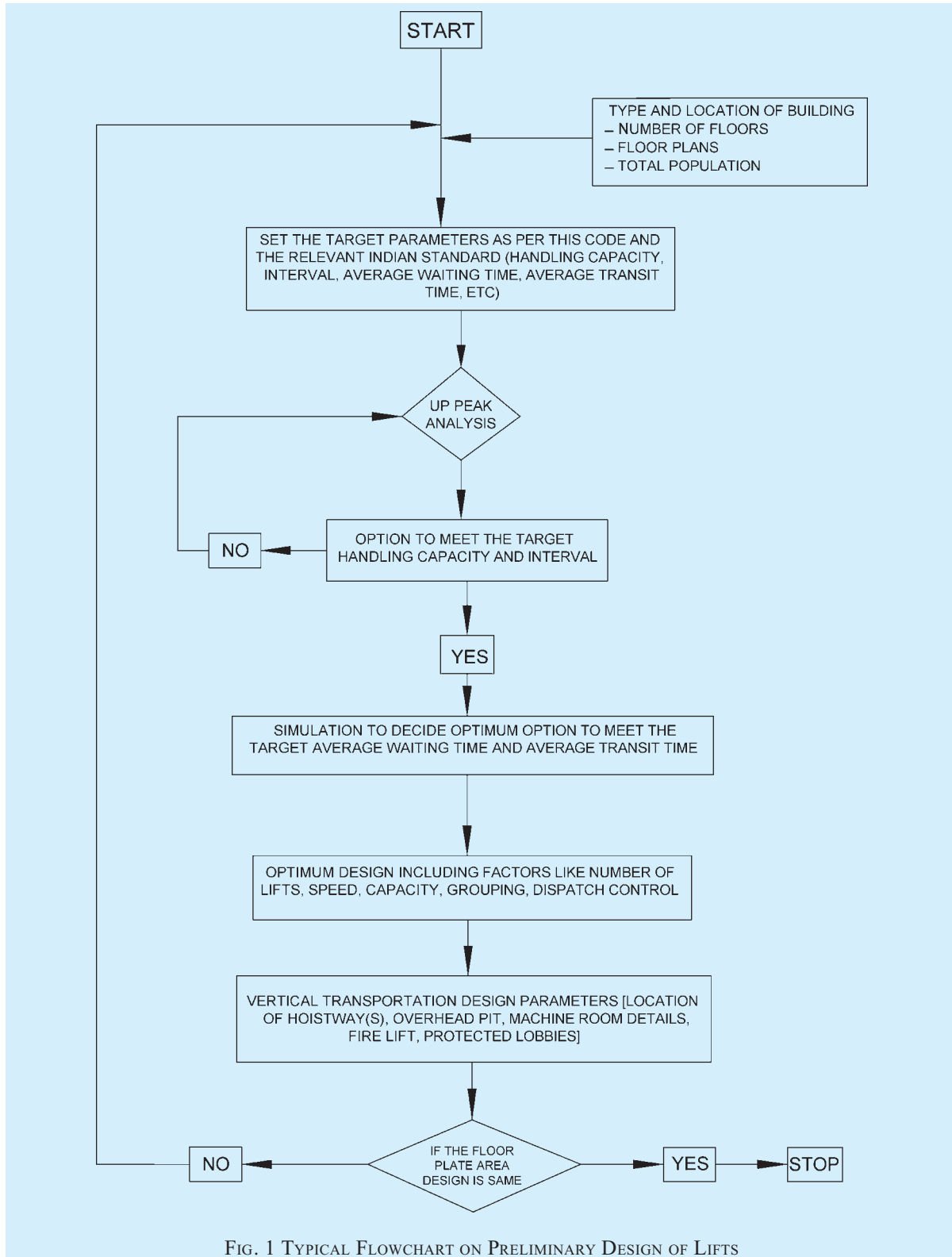

FIG. 1 TYPICAL FLOWCHART ON PRELIMINARY DESIGN OF LIFTS

4.2 Preliminary Lift Planning

4.2.1 Two models can be used for lift traffic analysis and design:

- a) The first model uses a calculation method based on mathematical formulae. This classical model uses the pure up-peak condition as this provides a well-defined, simple traffic pattern amenable to mathematical analysis. These calculations can be carried out manually, using a spreadsheet or by using computer based programme.
- b) The second model is based on discrete digital simulation of the movement of lifts in a building and the passenger dynamics. This simulation model allows very complex situations to be analyzed and is generally capable of better evaluations. However, simulation approaches and algorithms vary with software ranging from crude to very sophisticated. With the varied approaches and lack of consensus on simulation approaches and how to apply simulation this standard does not define standards for simulation.

Generally, if a lift system (using a conventional landing call system) is sized correctly for the up-peak traffic pattern, all other traffic patterns should be adequately served. The notable exceptions to this, are:

- 1) Hotels where check-in/check-out clashes with meal times;
- 2) Hospitals;
- 3) Buildings that open at specified times (Example, stock exchanges, movie theatres, stadiums);
- 4) Buildings with 24×7 operation and shift changes (Example, BPO/ITES buildings);
- 5) Buildings with amenities located at higher floors (Example, roof top restaurant, cafeterias, health clubs);
- 6) Residential buildings (sometimes two-way traffic is considered);
- 7) Buildings with multiple entry levels;
- 8) Parking towers;
- 9) Schools where students change floors or buildings at the beginning and end of classes; and
- 10) Mixed-use buildings.

Methods of calculating the traffic handling capabilities of lifts were first devised for office buildings. In due course detailed modifications were devised to suit other applications without altering the basic principles. The application to office buildings is the most frequently

used, and is outlined in 4.2.2 to 4.2.10 as a general approach to lifting.

Subsequently, traffic conditions other than up peak are examined as also building types other than office. It is recommended that calculations based on the classical model should be carried out in order to obtain an understanding of the various factors. A simulation may then be performed in order to cover special situations or to obtain information not provided by the calculation method.

4.2.2 Population

The first point to be ascertained from the owner/ developer or proposed occupier is the total building population. If a definite population figure is not available, then an estimation should be made using floor areas, more specifically, the net usable area (NUA). The NUA excludes circulation areas (stairs, corridors, foyers, etc), structural intrusions (columns, ducts, etc) and facilities (pantry, kitchens, toilets, conference rooms, training rooms, server rooms, storage areas, etc).

The number of people occupying the net usable area can vary according to the usage pattern or building type. Because of the criticality of establishing the population, it is recommended that the architect/engineer should prepare a typical test fit to establish an estimate of the population. The test fit estimates can be validated from population counts from buildings with similar usage patterns and types.

The designers need to understand the clear circulation and movement pattern of the occupants (and goods) of a building and design to facilitate the circulation and movement. Table 1 gives typical values for the density of population.

Table 1 Occupancy Area Per Person in Office Buildings
(Clause 4.2.2)

Sl No.	Building Type	Open Plan/ Hall Seating	Cellular Plan/ Cabins
(1)	(2)	(3)	(4)
i)	Premium	10 m ²	12 m ²
ii)	Regular	8 m ²	10 m ²
iii)	Low end	5 m ²	8 m ²

For certain specialized building functions such as BPO, areas ranging from 6 m² to 10 m² per person may be considered.

4.2.3 Quantity of Service

It is measured in terms of the total number of passengers handled during the peak 5 min period of the day. This is calculated by determining the number of trips made by the lifts over the peak 5 min period and then

multiplying it by the average number of passengers carried in each trip. The target handling capacity as a percentage of the building population is usually the estimated value of passenger arrival rate for the 5 min up-peak period. The minimum recommended quantity of service is given in Table 2.

This would vary depending on various factors like starting time (fixed or flexi-time), nearness to fast access routes like mass rapid transport systems, express ways, major roads, etc.

Table 2 Recommended Quantity of Service in Office Buildings
(Clause 4.2.3)

Sl No.	Type of Occupancy	Quantity of Service Percent
(1)	(2)	(3)
i)	Multi tenancy	10 to 15
ii)	Single tenancy	15 to 25

4.2.4 Quality of Service

It is very difficult to get real indications of passenger waiting time and lobby queuing from the classic calculation models. Therefore, interval is considered as the measure. During pure up-peak traffic, the interval or the average time between successive arrivals of the lift cars at the main lobby is generally considered as an indicator of passenger waiting time. Table 3 gives the quality of service based on interval.

If interval is used as an indicator of quality of service, it should be noted that passenger average waiting time depends on the car occupancy, the handling capacity *vis-a-vis* the passenger arrival rates, the control systems, etc. The average waiting time approximates 75 percent to 85 percent of the interval for average car occupancy of 80 percent of the actual lift capacity provided the handling capacity is equal to or better than the peak arrival rate. Beyond 80 percent car loading passenger average waiting time increases exponentially and cannot be approximated from interval. Table 4 gives the recommended quality of service measured as average waiting time.

Table 3 Recommended Quality of Service in Office Buildings (Based on Interval)
(Clause 4.2.4)

Sl No.	Quality of Service	Interval s
(1)	(2)	(3)
i)	Excellent	Less than 25
ii)	Very good	25 to less than 30
iii)	Good	30 to less than 35
iv)	Fair	35 to less than 40
v)	Poor	40 to less than 45
vi)	Unsatisfactory	45 and above

Table 4 Recommended Quality of Service in Office Buildings (Based on Average Waiting Time)
(Clause 4.2.4)

Sl No.	Class of Building	Average Waiting Time s
(1)	(2)	(3)
i)	Premium	< 25
ii)	Regular	25 to 35

4.2.5 Traffic Analysis Equations

The classical method to size a lift installation requires the determination of the time, in second, that it takes for a single lift to make a round trip around the building during the up-peak traffic condition. This is called the round trip time and is given by:

$$RTT = 2Ht_v + (S + 1)(T - t_p) + 2Pt_p$$

where

- N = number of floors above main terminal floors,
- H = average highest reversal floor
- $= N - \sum_{i=1}^{N-1} (i / N)^P$,
- S = average no of stops
- $= N \left[1 - \left(1 - \frac{1}{N} \right)^P \right]$,
- P = average passengers carried
- $= 0.8 \times \text{maximum actual car capacity,}$
- t_v = single floor transit time = average inter floor distance/rated speed,
- T = door operating time ($t_c + t_o$) + single floor flight time $t_f(1)$, and
- t_p = passenger transfer time.

The derivation of the round trip time equation assumes the following:

- a) Traffic pattern corresponds to a pure up-peak.
- b) Passengers arrive according to a rectangular probability distribution.
- c) Lifts, on an average, fill to 80 percent of the actual car capacity by numbers irrespective of the weight of each passenger or the space that maybe occupied
- d) All floors are equally populated.
- e) Rated speed is achieved in a single floor jump.
- f) Interfloor heights are equal.
- g) Door dwell time does not exceed the calculated passenger transfer time.

Interval, $INT = RTT / L$, where L is the number of lifts in a single group.

$$5 \text{ min handling capacity, } HC = \frac{300 \times P \times L \times 100 / \text{Population}}{RTT}$$

or

$$\frac{300 \times P \times 100 / \text{Population}}{INT}$$

The down peak round trip time is estimated as:

$$RTT_{\text{downpeak}} = Nt_v + (0.5S + 1)(T - t_v) + 2Pt_p$$

The mid-day round trip time is estimated as:

$$RTT_{\text{mid-day}} = 2Ht_v + 2S(T - t_v) + 4Pt_p$$

An estimation of interfloor performance can be obtained using:

$$AWT_{\text{interfloor}} = INT_{\text{uppeak}} + \left(0.22 + 1.78 \frac{A_{\text{interfloor}}}{HC_{\text{uppeak}}} \right)$$

where $A_{\text{interfloor}}$ is the number of passengers arriving during the interfloor period.

4.2.6 Configuration of Lifts: Number

Determination of number of lifts depends on the required quality and quantity of service. It should be noted here that grouping of lifts and location should be given adequate attention.

If a bank of two lifts or more is required to meet the anticipated traffic requirements, they have to be oriented to facilitate grouping. Individual lifts will not achieve the required quantity and quality of service.

4.2.7 Configuration of Lifts: Capacity

Determination of car capacity depends on the required quality and quantity of service. A larger car, while improving the handling capacity might adversely impact the quality of service.

4.2.8 Configuration of Lifts: Speed

In addition to the speeds derived from the calculations for handling capacity and interval, the nominal travel time is used for selecting suitable rated speeds. The higher the building, the faster lifts are needed. The recommended values for nominal travel time in case of an office, commercial or hotel building are given in Table 5.

Table 5 Recommended Nominal Travel Time for Office, Commercial or Hotel Buildings
(Clause 4.2.8)

Sl No.	Level	Nominal Travel Times
(1)	(2)	(3)
i)	Excellent	15 to 25
ii)	Good	> 25 to 35
iii)	Satisfactory	> 35 to 45

4.2.9 Configuration of Lifts: Layout

The shape and size of a passenger lift car bears a distinct relation to its efficiency in traffic handling. A study of the most suitable proportions for passenger lifts reveals that the width of the lift well entrance is the basic element in the determination of the best proportions. In other words, the width of the car is determined by the width of the entrance and the depth of the car is regulated by the loading per square metre permissible under this standard.

Centre opening doors are the most practicable and the most efficient entrance units for passenger lifts. Given the same door speed, the centre opening is much faster than the side opening type. For passenger lifts, wider cars are preferred as the ingress and egress efficiency is higher. For service/freight/ stretcher lifts deeper cars are preferred, so as to easily carry the stretcher/goods.

While sizing the hoist-ways, the possible construction inaccuracies have to be considered. Further where high speeds lifts are being considered the hoist-ways need to be designed to address the impact of the wind tunnel effect.

4.3 Planning for Specific Building Features

4.3.1 Special Building Facilities

Facilities like cafeteria, food courts, restaurants, gymnasias, etc, in the building impact the circulation patterns in a building and should be considered for lift traffic design.

4.3.2 Basement Service

Buildings are sometimes designed with car parks or other facilities at basement levels below the terminal floor. Such floors, if they are served by the main lifts have an adverse impact on the up-peak, down-peak and mid-day traffic patterns. During up-peak conditions, this may cause lifts to arrive at the main terminal already partly full causing confusion. In such a situation people have a tendency to push both up and down buttons resulting into deterioration of the lift service.

If basement floors are served by only a part of a lift group, passengers experience difficulty in selecting the correct lifts out of a group that will serve the basement. It is therefore better to provide basement service to the main lobby by a separate group of 'shuttle' lifts so as to avoid compromising the traffic handling capability of the main lift group.

4.3.3 Multiple Entry Levels

Some buildings have main entry points at more than one level. The effect of more than one main terminal is disruptive and adversely impacts effective circulation and movement. If there are more than one entrance

levels, means should be provided to bring all the routes to a single terminal floor. If this is not possible, then the lift system planning should take into account the extra times incurred stopping and loading at multiple entry floors. Another difficulty is in deciding whether the building population will use each entrance equally. In the absence of any guidance, the solution is to assume an entrance bias with an additional 10 percent and size the lifts to meet the additional required handling capacity.

The loss of lift efficiency because of multiple entry levels could be as high as 15 percent per additional entry level. Both basement service and multiple entry level buildings with lifts serving all floors also can impact the security of the building.

4.3.4 Non-Smoking Buildings

When buildings are defined as non-smoking buildings, designers need to factor in the additional load put on the lifts on account of the additional trips that smokers make to go outside the building. It is appropriate to provide pressurized smoking zones at the floor level rather than require smokers to make additional trips.

4.3.5 Reserved Lifts

When lifts have to be reserved for VIP personal movement, designers should not consider these lifts as part of the lift group.

4.3.6 Zoning (Vertical)/Sky Lobbies in Very Tall Buildings

As the number of floors served increases, the values of H and S also increase, adversely impacting the round trip time and performance of the lift system. This has led to the concept of zoning in tall buildings. In stacked

zoning, a tall building is effectively divided into horizontal layers or stacks. RTT, quality and quantity of service can be arrived at separately for each zone. The desired level of service can be attained by adjusting two parameters in this case — the number of lifts and the number of floors in the zone. The round trip time for each zone is given by:

$$RTT = 2Ht_v + (S + 1) (T - t_v) + 2Pt_p + 2[t_{\text{express}} - t_f(1)]$$

where t_{express} is the flight time from the main terminal to the express zone terminal/sky lobby.

The round trip time for shuttle lifts serving only 2 floors — main terminal and sky lobby is given by:

$$RTT = 2T + 2Pt_p$$

4.4 Planning For Specific Building Types

4.4.1 Residential Buildings

The peak traffic condition occurs during the morning down-peak when many adults and children are leaving for work and school at the same time. Population assumptions would also need to consider the service staff, drivers of cars, etc. For high rise buildings the delivery of newspapers and milk and disposal of garbage are also required to be considered.

In the luxury housing segment, where the number of ratio of service staff to residents is fairly high, separate service lifts may be required for door deliveries and service staff. Typical average daily population for a residential building is given in Table 6.

The passenger handling capacity shall be as given in Table 7. The intervals shall be as per values in Table 8. Table 9 gives the recommended quality of service

Table 6 Typical Average Population for Residential Buildings
(Clause 4.4.1)

Sl No.	Type of Apartment	Number of Bedrooms Per Apartment				
		1	2	3	3 With Servant Quarters	4 With or Without Servant Quarters
(1)	(2)	(3)	(4)	(5)	(6)	(7)
i)	High end apartments:					
a)	Residents	2 to 3	3 to 4	5	5	5 to 6
b)	Resident service staff	0	0	0	1	1
c)	Floating service staff	1	2 to 3	3 to 4	3 to 4	4 to 5
ii)	Mid end apartments:					
a)	Residents	3	4	5	5	5 to 6
b)	Resident service staff	0	0	0	1	1
c)	Floating service staff	1	1	2 to 3	2 to 3	3 to 4
iii)	Low end apartments:					
a)	Residents	4 to 5	5 to 6	NA	NA	NA
b)	Floating service staff	0.5	0.5	NA	NA	NA

NOTE — Unless separate lifts are provided for service staff, due consideration for service staff shall be given while calculating the required number of lifts.

measured as average waiting time for residential buildings and Table 10 gives the nominal travel times.

Sizing of lifts should consider the requirement to shift the stretchers, heavy material, etc and it is recommended that at least one lift in each building should be a deep car which can accommodate a regular ambulance stretcher.

Table 7 Recommended Handling Capacity for Residential Buildings
(Clause 4.4.1)

Sl No.	Class of Building	Handling Capacity Percent
(1)	(2)	(3)
i)	High end building	> 8
ii)	Mid end building	6 to 8
iii)	Low end building	5 to 7

Table 8 Recommended Quality of Service for Residential Buildings (Based on Time Interval)
(Clause 4.4.1)

Sl No.	Class of Building	Interval s
(1)	(2)	(3)
i)	High end building	≤ 60
ii)	Mid end building	61 to 80
iii)	Low end building	81 to 100

Table 9 Recommended Quality of Service in Residential Buildings (Based on Average Waiting Time)
(Clause 4.4.1)

Sl No.	Class of Building	Average Waiting Time s
(1)	(2)	(3)
i)	High end building	≤ 30
ii)	Mid end building	31 to 45
iii)	Low end building	46 to 60

Table 10 Recommended Nominal Travel Time for Residential Buildings
(Clause 4.4.1)

Sl No.	Level	Nominal Travel Time s
(1)	(2)	(3)
i)	High end building	25 to 35
ii)	Mid end building	36 to 45
iii)	Low end building	46 to 60

NOTE — In case of super high rise buildings considering limit of lift speed as 10 m/s, the travel time may be longer than specified above.

4.4.2 Hospitals

Factors to be considered include number of staff and shift patterns, number of visitors and visiting hours, location of operation theatres, facilities, delivery of housekeeping supplies, waste disposal, evacuation procedures and segregation of sterile areas. When carrying out traffic analysis for hospitals, designers should consider establishing average car loading by volume rather than by weight. Arrival rates may approximate 10 percent to 15 percent and interval may be 30 s to 50 s.

The sizing of the lift car and doors should be such that a standard hospital stretcher and attendant can be easily accommodated. Where the hospital bed is likely to be moved the lift car should be able to accommodate the standard hospital bed including the auxiliary support equipment like oxygen cylinders, etc.

In large hospitals it is recommended that the lifts for the patients/hospital beds (or stretchers) should be separated from the lifts for staff/visitors.

NOTE — For hospital buildings, designers should also consider that in an emergency a number of patients would require to be evacuated on stretchers.

4.4.3 Hotels

The most demanding time is during the check-in and check-out period and two-way traffic occurs during this period with guests going to and from rooms and restaurants and in and out of the hotel. Calculations should be made assuming an equal number of up and down stops during this period. Average room occupancy may range from 1.5 to 2 persons and arrival rates from 10 to 15 percent. Security considerations need to be taken into account whilst establishing the circulation and lift requirements. Escalators should be employed for heavy short range movements such as from the lobby to banquet/ function level. Adequate number of service lifts need to be provided for service movement of housekeeping and room service staff as well as movement of material.

4.4.4 Retail — Malls with Multiplexes

Pedestrian movement in retail establishments like malls is generally centered on escalators, and lifts do not play a major part. However, provision should be made for movement of shopping trolleys, wheel chairs, perambulators and persons with limited mobility from one level to another. A commonly applied solution is the installation of inclined moving walks. Where lifts are provided, assumptions of lift car sizing should take into account space occupied by trolleys and shopping bags. Where multiplexes are located on the upper floors, the last movie of the day gets over after the mall is closed at which time the escalators might not be available. In such cases the lift provision has to be

adequate to handle the egress of the total multiplex population.

4.4.5 Airports/Railway Stations

While moving walks and escalators greatly improve the building circulation, the use of lifts has to be considered for persons with limited mobility and for movement of baggage trolleys from one level to another. The RTT equation of 4.2.5 may be used, but care may need to be taken in the assumptions of lift car occupancy levels taking into account space occupied by trolleys.

4.4.6 Multi-Level Car Parking

Multi-level car parks may be standalone public car parks or attached to office, retail or residential complexes. These car parks may be fully automated where drivers would leave the cars inside or on a trolley at the entry floor and the car is parked and retrieved automatically. The other alternative would be for the use of car lifts and/or ramps.

When the movement of the cars is dependent on car lifts, detailed study has to be carried out to establish the required number of car lifts ensuring that average car retrieval/parking time does not exceed 2 min. The sizing of the car lifts has to be adequate to fit the largest vehicle that is intended to be transported as well as adequate space to enable opening of the doors to enable evacuation of passengers in the eventuality of an entrapment. Designers will also need to take into account the probability of queues developing and provide for holding lanes.

4.4.7 Multi-Level Car Parking Passenger Traffic

When car lifts or ramps are the means for parking the cars, then means would need to be provided for the movement of passengers from and to the parking floors. If the main building lifts also serve the parking floors, it is to be noted that, performance will be adversely impacted due to multiple entry floors. Additional entry floors will also affect the security of the building. It is therefore recommended that separate lifts should be considered to move passengers. If separate parking lifts are provided, the basic RTT equation of 4.2.5 may be used. Average vehicle occupancy may be considered as 1.5 per car for office car parks, 4 for airports and retail and 2 elsewhere.

4.4.8 Schools and Other Educational Institutions

In schools and other educational institutions, the traffic flow would consist of peak demand for short duration that would exist just before the start or after finishing of a class or lecture. It is unlikely that an economical solution can be implemented for such high peak requirements. Therefore the design of the building has to be such that heavy stair usage is facilitated.

4.4.9 Buildings with 24 × 7 Operations

In buildings operating 24 × 7 (round the clock), the peak traffic conditions would not be a typical up peak but will occur during shift changes. The handling capacity should take into account the incoming as well as outgoing traffic. Calculations shall be made assuming both up and down stops during this period. Particular attention should be paid while designating the drop off points, these should be assigned to a level so as to not increase the burden on the system. Designers need to consider that the lifts in such buildings would have a significantly higher number of starts/stops per hour than a conventional building.

4.4.10 Observatory

The height at which the observatory is located and the number of people expected at the observatory level shall decide the speed and the number of lifts. The circulation logic is crucial in locating the observatory lifts. Also, if the observatory is connected with lounge/café/souvenir shops, etc, separate service lifts may need to be provided.

4.5 Other Considerations

Designers need to be aware that the door opening and closing times, acceleration and deceleration times, etc, would vary between the suppliers and equipment types and can impact the overall lift performance. The dispatch algorithms and controller responses would also vary between the suppliers and the equipment types and can impact the actual operational results.

Lifts will breakdown as well require to be shut-down for regular maintenance and repairs. Lift availability might be hampered during renovation of the building as a lift might be taken up for movement of material and debris. Designers should take into consideration the impact of such non-availability of lifts. The provision of well-located and easily accessible stairs can considerably lessen the demands on the lifts and therefore architect/engineer should consider this aspect in the layout.

4.5.1 Lift Speed

For passenger lifts in a building, the general recommendations as given in Table 11 may be followed.

4.5.2 Quiet Operation of Lifts

Every precaution should be taken with passenger lifts to ensure quiet operation of the lift doors and machinery. The insulating of the lift machine and any motor generator from the floor by rubber cushions or by a precast concrete slab with rubber cushions, prevents transmission of most of the noise. In this connection, see also good practice [8-5A(4)] and Part 8 'Building Services, Section 4 Acoustics, Sound Insulation and

Noise Control' of the Code for some useful recommendations.

Table 11 Lift Speed
(Clause 4.5.1)

Sl No. (1)	No. of Floors (2)	Speed m/s (3)
i)	Up to 6	0.6 to 1.0
ii)	7 to 15	1.0 to 1.5
iii)	16 to 20	1.5 to 1.75
iv)	21 to 30	1.75 to 2.5
v)	31 to 45	3.0 to 4.0
vi)	46 to 60	4.0 to 6.0
vii)	Above 60	6.0 and above

NOTES

1 Above table is considering buildings with average floor height of 3.0 m.

2 For office buildings average floor height is 4.2 m (see Table 5 and Table 10).

3 Finalizing the lift speed for any building depends on detailed traffic analysis because number of floors, area per floor, area per person and class of building are crucial factors, which serve as inputs for such traffic analysis.

4 Finalizing the speed for hotel depends on the number of keys per floor and similarly for an observatory depends on the number of expected footfall.

5 For any building, the speed of the lifts will have to be validated against the total population and travel height of the building.

5 LIFT ARRANGEMENTS AND PLANNING DIMENSIONS

The appropriate aspect of lift installation shall be discussed during the preliminary planning of the building with all concerned parties, namely, client, architect, consulting engineer and/or lift manufacturer. This enables the lift manufacturer to furnish the architect and/or consulting engineer with the proposed layout or *vice-versa*.

5.1 Exchange of Information

5.1.1 The guidelines laid down together with Fig. 2 will enable the preliminary scheme for the installation to be established. Figure 2 shows only some of the typical arrangements and variations are possible with respect to number of lifts and the layout of lifts especially when destination control system (DCS) is used instead of conventional group control system

Although the recommended outline for the various classes of lifts enable the general planning details to be determined by the architect/engineer, these should be finally settled at the earliest possible stage by detailed investigation with the purchaser's representative reaching agreement with the lift manufacturer (where necessary) before an order is finally placed. This will enable a check to be made and information to be exchanged on vital matters such as:

- a) Number, capacity, speed and disposition of the

lifts necessary to give adequate lift service in the proposed building;

- b) Provision of adequate access to the machine room;
- c) Loads which the lift will impose on the building structure, and the holes to be left in the machine room floor and cut-outs for wall boxes for push-buttons and signals;
- d) Necessity for and type of insulation to minimize the transmission of vibration and noise to other parts of the building;
- e) Special requirements of local authorities and other requirements set out in the 'planning permit';
- f) Need for the builder to maintain accuracy of building as to dimensions and in-plumb;
- g) Periods of time required for preparation and approval of relevant drawings for manufacturing and the installation of the lift equipment;
- h) Requirements for fixing guide brackets to the building structure;
- j) Time at which electric power will be required before completion to allow for testing;
- k) Requirements for electrical supply feeders, etc;
- m) Requirements for scaffolding in the lift well and protection of the lift well prior to and during installation of equipment; and
- n) Delivery and storage of equipment.

5.1.2 Information to be provided by Architect or Engineer

As a result of preliminary discussions, the drawings of the building should give the following particulars and finished sizes:

- a) Number, type and size of lifts and position of lift well;
- b) Particulars of lift well enclosure;
- c) Size, position, number and type of landing doors;
- d) Number of floors served by the lift;
- e) Height between floor levels;
- f) Number of entrances;
- g) Total headroom;
- h) Provision of access to machine room;
- j) Provision of ventilation and, if possible, natural lighting of machine room;
- k) Height of machine room;
- m) Depth of lift pit;
- n) Position of lift machine, above or below lift well;

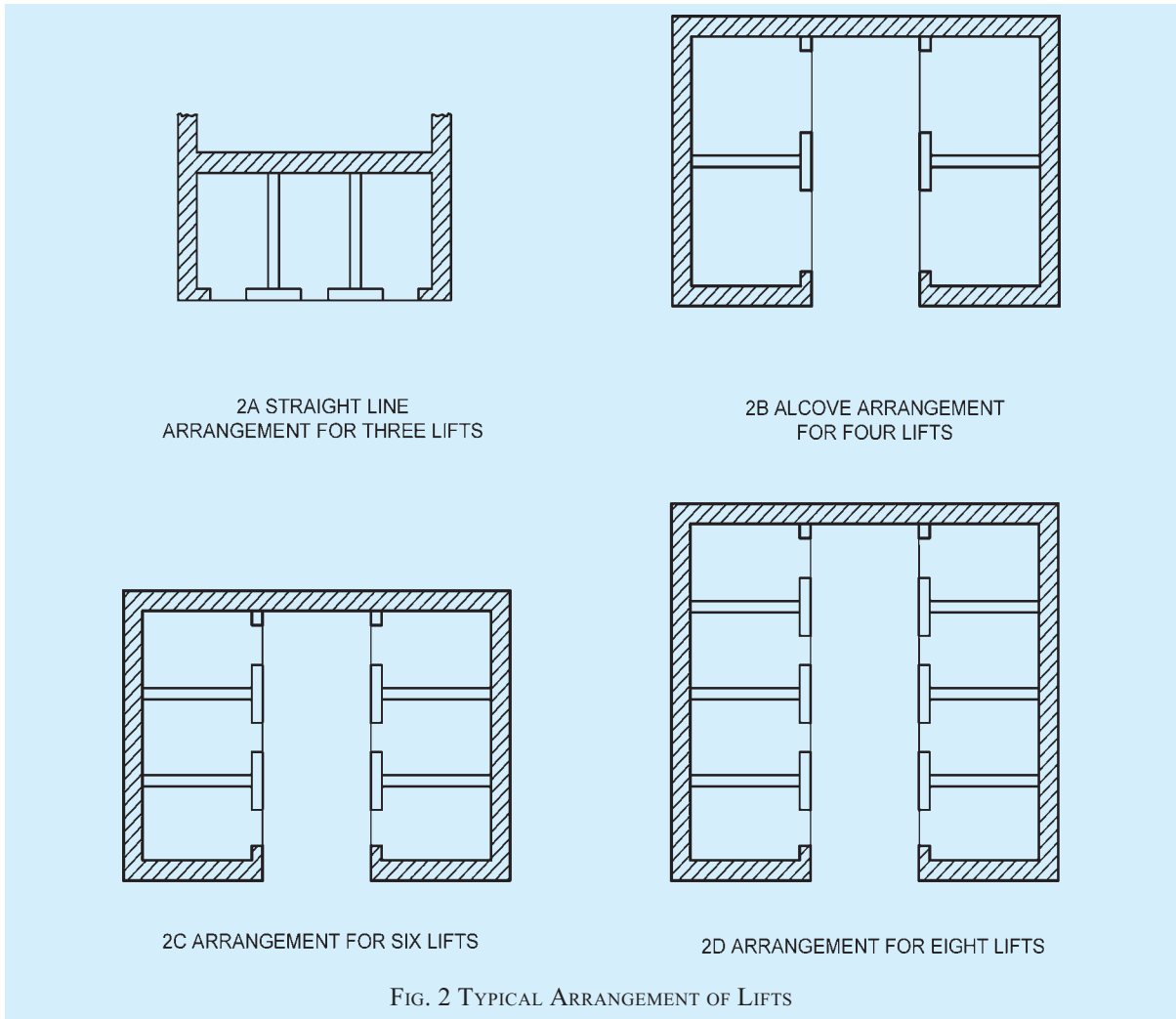

FIG. 2 TYPICAL ARRANGEMENT OF LIFTS

- p) Size and position of any trimmer joists or stanchions adjacent to the lift well at each floor;
- q) Size and position or supporting steel work at roof levels;
- r) Size and position of any footings or grillage foundations, if these are adjacent to the lift pit; and
- s) In the case of passenger lifts whether the lift cage is required to carry household luggage, such as refrigerator, steel almirah, etc.

5.2 The lift lobby should be designed appropriately since this has bearing on the traffic handling especially when more number of lifts are involved. In a dual line arrangement (lifts opposite to each other) the lobby should be between 1.5 times and 2.5 times the depth of one car. Typically, the greater the number of lifts, the bigger the multiplier to be used. As an example, a quadruplex may use 1.5 to 2, where as an octoplex will need 2 to 2.5. For in-line (single line) arrangements, the lobby can be typically half of the above recommendations.

It is preferable that the lift lobby is not used as a thoroughfare. If unavoidable the lift corridor shall take into account space for people who are moving.

5.3 The architect/engineer should advise the lift manufacturer, if the Authority has any special requirements regarding lifts in buildings in the administrative area concerned.

5.4 The architect/engineer should inform the lift manufacturer of the dates when the erection of the lift may be commenced and is to be completed so that sufficient time is allowed for the manufacture and erection of the lift.

5.5 When submitting application for a building permit to the local Authority, the building plans shall include the details of lifts (number of lifts duly numbered, location, type, type of doors, passenger capacity and speed).

5.6 Positioning of Lifts

A thorough investigation should be made for assessing the most suitable position for lift(s) while planning the

building. It should take into account future expansions, if any. Though each building has to be considered individually for purposes of location of lifts, factors influencing the locations of passenger and goods lifts are given in 5.6.2 to 5.6.4.

5.6.1 Arrangement of Lifts

The lifts should be easily accessible from all entrances to the building. For maximum efficiency, they should be grouped near the centre of the building. It is preferable not to have all the lifts out in straight line and, if possible, not more than four lifts should be arranged in this manner. If more than 4 lifts have to be grouped together in a straight line, then destination control systems would require to be adopted. Further, the corridor should be wide enough to allow sufficient space for waiting passengers as well as for through passengers.

In some cases when there are more than three lifts, the alcove arrangement is recommended. With this arrangement, the lift alcove leads off the main corridor so that there is no interference by traffic to other groups or to other parts of the ground floor. This arrangement permits the narrowest possible corridors and saves space on the upper floors. Walking distance to the individual lift is reduced and passenger standing in the centre of the group can readily see all the lift doors and landing indicators. The ideal arrangement of the lifts depends upon the particular layout of the respective building and should be determined in every individual case. Some typical recommended arrangements are given in Fig. 2.

5.6.2 Passenger Lifts

5.6.2.1 Low and medium class flats

Where a lift is arranged to serve two, three or four flats per floor, the lift may be placed adjoining a staircase, with the lift entrances serving direct on to the landings. Where the lift is to serve a considerable number of flats having access to balconies or corridors, it may be conveniently placed in a well-ventilated tower adjoining the building.

5.6.2.2 Office buildings, hotels and high class flats

In general the arrangement as recommended in 5.6.1 should be followed. However, in case this is not possible, it is desirable to have at least a battery of two lifts at two or more convenient points of a building. If this is not possible, it is advisable to have at least two lifts side by side at the main entrance and one lift each at different sections of the building for inter-communication. When two lifts are installed side by side, the machine room shall be suitably planned with sufficient space for housing the machine equipment. The positioning of lifts side by side gives the following advantages:

- a) All machines and switch gear may be housed in one machine room,
- b) Lifts can be inter-connected more conveniently from an installation point of view, and
- c) Greater convenience in service owing to the landing openings and each floor being adjacent.

5.6.2.3 Shops and departmental stores

Lifts in shops and stores should be situated so as to secure convenient and easy access at each floor.

5.6.2.4 For buildings with more than 12 floors, where passenger and service lifts are provided in one lobby, it is recommended to have group control for all the lifts.

5.6.3 Goods Lifts

The location of lifts in factories, warehouses and similar buildings should be planned to suit the progressive movement of goods throughout the buildings, having regard to the nature of position of the loading platforms, railway sidings, etc. The placing of a lift in a fume or dust laden atmosphere or where it may be exposed to extreme temperatures, should be avoided, wherever possible. Where it is impossible to avoid installing a lift in an adverse atmosphere, the electrical equipment should be of suitable design and construction to meet the conditions involved.

Normally goods lifts have lower speeds than passenger lifts for the same travel because traffic conditions are less demanding, and more time is required for loading and unloading. As loads for goods lifts increase in size and weight, so the operation of loading and unloading becomes more difficult. Therefore, it is usual to require greater accuracy of levelling as the capacity of the goods lift increases.

A large capacity goods lift operating at high speed is often a very uneconomical solution. The inherent high cost is enhanced due to the very small demand for such equipment, much of which is custom made. The high capital cost of the lift, building work and electrical supply equipment usually shows a much smaller return as an investment than more normal sizes of lifts.

5.6.4 Hospital Bed Lifts

Hospital bed lifts should be situated conveniently near the ward and operating theatre entrances. There shall be sufficient space near the landing door for easy movement of stretcher/bed. It is convenient to place the passenger lifts in a hospital, near the staircases.

5.7 General Arrangement Drawings (GAD)

The general arrangement drawings should be prepared

by the lift manufacturer. The lift manufacturer requires sufficient information for the preparation of working drawings and is usually obtained from architect's drawings supplemented by any information obtained from the site and by collaboration with the other contractors.

General arrangement drawings showing the layout of lifts duly numbered, details of builders work, for example, holes in walls for guide fixing, holes in machine room floor for ropes and conduits, recesses for landing sills, supports for lift machine and loads imposed on the building should be submitted by the lift manufacturer to the architect/engineer for written approval.

5.8 Additional Requirements for Passenger, Goods and Service Lifts

5.8.1 Bottom Car Clearance

When the car rests on its fully compressed buffer there shall be a vertical clearance of not less than 600 mm between the pit floor and the buffer striker plate or the lowest structural or mechanical part equipment or device installed. The clearance shall be available beneath the whole area of the platform except for,

- a) guide shoes or rollers, safety jaw blocks, platform aprons, guards of other equipment located within 300 mm measured horizontally from the sides of the car platform; and
- b) compensating sheaves.

Provided that in all the cases, including small cars, a minimum clearance of 600 mm is available over a horizontal area of 800 mm × 500 mm.

Provided also that in all the cases, when the car rests on its fully compressed buffers, there shall be a vertical clearance of not less than 50 mm between any part of the car and any obstruction of device mounted in the pit.

5.8.2 Top Car Clearance

The vertical clearance between the car cross-head and the nearest overhead obstruction within 500 mm measured horizontally to the nearest part of the crosshead when the car platform is level with the top landing, shall be not less than the sum of the following:

- a) Bottom counterweight run-by.
- b) Stroke of the counterweight buffer used.
- c) One-half of the gravity stopping distance based on,
 - 1) 115 percent of the rated speed where oil buffers are used and no provision is made to prevent the jump of the car at counterweight buffer engagement; and

- 2) Governor tripping speed where spring buffers are used.

NOTE — The gravity stopping distance based on the gravity retardation from any initial velocity may be calculated according to the following formula

$$S = 51 V^2$$

where

S = free fall, in mm (gravity stopping distance), and
V = initial velocity, in m/s.

- d) 600 mm.

Where there is a projection below the ceiling of the well and the projection is more than 500 mm, measured horizontally from the centre line of the cross-head but over the roof of the car, a minimum vertical clearance not less than that calculated above shall also be available between the roof of the car and the projection.

Provided that the vertical clearance between any equipment mounted on top of the car and the nearest overhead obstruction shall be not less than the sum of the three items (a), (b) and (c) as calculated above plus 150 mm.

5.8.3 Bottom Run-by for Cars and Counterweights

The bottom run-by of cars and counterweights shall be not less than the following:

- a) 150 mm, where oil buffers are used.
- b) Where spring-buffers are used;
 - 1) 150 mm for controls as in 2.1.11.4 to 2.1.11.8, and
 - 2) Not less than the following for controls as in 2.1.11.1 to 2.1.11.3:

Rated Speed m/s	Run-by mm
Up to 0.125	75
0.125 to 0.25	150
0.25 to 0.50	225
0.50 to 1	300

5.8.4 Maximum Bottom Run-by

In no case shall the maximum bottom run-by exceed the following:

- a) 600 mm for cars; and
- b) 900 mm for counterweights.

5.8.5 Top Counterweight Clearances

The top counterweight clearance shall be not less than the sum of the following four items:

- a) Bottom car run-by.

- b) Stroke of the car buffer used.
- c) 150 mm.
- d) One-half the gravity stopping distance based on,
 - 1) 115 percent of the rated speed where oil buffers are used and no provision is made to prevent jump of the counterweight at car buffer engagement; and
 - 2) governor tripping speed where spring buffers are used.

5.9 Additional Requirements for Dumb Waiters

5.9.1 Top Car Clearance

The top car clearance shall be sufficient to avoid any protruding part fixed on the top of the car coming in direct contact with the ceiling or diverting sheave.

The clearance shall be calculated taking into account the following and shall not be less than the sum of the following four items:

- a) Bottom counterweight run-by.
- b) Stroke of the counterweight buffer used.
- c) Dimensions of the portion of the diverting sheave hanging underneath the ceiling in the lift well.
- d) 150 mm for compensating for gravity stopping distance and future repairs to the rope connections at counterweight and at the car or at the suspension points.

5.9.2 Bottom Car Clearance

The bottom car clearance shall be maintained in such a way that the counterweight shall not come in contact with the ceiling or any part hanging underneath the ceiling, when the car completely rests on fully compressed buffers, provided the buffers are spring type mounted on solid concrete or steel bed.

In case of wooden buffers the bottom car clearance shall be maintained in such a way that the total downward travel of the car from the service level of the immediate floor near the pit, shall not be more than the top counterweight clearance, when the wooden buffers are completely crushed.

5.9.3 Top Counterweight Clearance

The top clearance for the counterweight can be calculated taking into account the following and shall not be less than the sum of the following three items:

- a) Car run-by.
- b) Compression of the buffer spring or height of the wooden block used as buffer.
- c) 150 mm to compensate for gravity stopping distance for counterweight and any future

repairs to rope connections at the counterweight at the car ends or at the suspension points.

5.9.4 Run-by for Cars and Counterweights

- a) *Minimum bottom run-by* — The bottom run-by for cars and counterweights shall not be less than 150 mm.
- b) *Maximum bottom run-by* — In no case shall the maximum bottom run-by exceed 300 mm.

5.10 Planning for Dimensions

5.10.1 General

The dimensions of lift well have been chosen to accommodate the doors inside the well which is the normal practice. In special cases, the door may be accommodated in a recess in the front wall, for which prior consultation shall be made with the lift manufacturer.

5.10.2 Plan Dimensions

All plan dimensions of lift well given hereunder, are the minimum clear plumb sizes. The architect/engineer, in conjunction with the builder, shall ensure that adequate tolerances are included in the building design so that the specified minimum clear plumb dimensions are obtained in the finished work.

NOTE — The words 'clear plumb dimensions' should be noted particularly in case of high rise buildings.

Rough opening in concrete or brick walls to accommodate landing doors depend on design of architrave. It is advisable to provide sufficient allowances in rough opening width to allow for alignment errors of opening at various landings. When more than one lift is located in a common well, a minimum allowance of 150 mm for separator beams shall be made in the widths shown in Tables 1 to 4.

Where the governor operated counterweight safety is required under conditions stipulated in good practice [8-5A(5)], the tabular values should be revised in consultation with the lift manufacturer.

For outline dimensions of lifts having more than one car entrance, lift manufacturers shall be consulted.

5.10.3 Outline Dimensions

5.10.3.1 The outline dimensions of lift shaft, machine-room, pit depth, overhead and raw door opening size for lifts to which this Subsection applies are specified in Tables 12 to 23 as indicated below:

a) Machine room lifts:	
1) Recommended dimensions of passenger lifts and service lifts	: Table 12
2) Recommended dimensions of hospital bed/stretchers lifts	: Table 13
3) Recommended dimensions of goods lifts with machine room	: Table 14
4) Recommended dimensions of machine room height, overhead, pit depth for passenger, goods, stretcher/hospital lifts with machine room	: Table 15
5) Recommended dimensions of automobile lifts with machine room — Through type car	: Table 16
6) Recommended dimensions of dumbwaiter lifts	: Table 17
b) Machine room-less lifts:	
1) Recommended dimensions of passenger lifts MRL	: Table 18
2) Recommended dimensions of stretcher/hospital lifts MRL	: Table 19
3) Pit depth for passenger/stretcher/hospital lifts MRL	: Table 20
4) Overhead height for passenger and stretcher/hospital lifts MRL	: Table 21
5) Recommended dimensions of goods lifts MRL	: Table 22
6) Recommended dimensions of automobile lifts MRL	: Table 23

5.10.3.2 Minimum floor to floor height

Minimum floor to floor height for landings on same side for horizontally sliding door is $f+750$ mm, where 'f' is clear entrance height, in mm.

6 CIVIL AND ELECTRICAL REQUIREMENTS FOR LIFTS

6.1 Civil Requirements

Lift well enclosures, lift pits, machine rooms and machine supports besides conforming to the essential requirements given below should form part of the building construction and comply with the lift manufacturer's drawings.

6.1.1 Requirements of Lift Well Enclosure

The requirements of lift well enclosures are as given hereunder:

- a) *Totally enclosed well* — Lift wells shall be totally enclosed by imperforate walls, floor and ceiling, constructed for protection against all weather and of dust free surface material or should be painted to minimize dust circulation on to moving apparatus and from being pumped by the car movement in to machine room or on to landings and shall be 120 min fire-resistant.

The lift well may have openings for landing doors, inspection and emergency doors, vent openings for escape of gases and smoke in case of fire, ventilation openings, openings in the machine room floor for connecting lift components such as ropes, cables, etc.

- b) *Partially enclosed well* — In case of partially enclosed lift wells used for applications for example, observation lifts in connection with galleries or atriums, etc, the well does not need to be totally enclosed, provided the height of the enclosure at places normally accessible to persons is sufficient to prevent such persons:

- 1) being endangered by moving parts of the lift; and
- 2) interfering with the safe operation of the lift by reaching lift equipment within the well either directly or with hand held objects.

The height of the enclosure shall be minimum 3.5 m at the landing door side. The height of enclosure at other sides shall be 2.5 m minimum when the horizontal distance between the moving parts of the lift and enclosure is 0.5 m minimum. The height of enclosure at other sides may be reduced to 1.1 m progressively if the horizontal distance between the moving parts of the lift and enclosure increases to 2 m. The enclosure shall be located within 150 mm of the edge of the floor. The enclosure shall be imperforate and made of non combustible material.

Table 12 Recommended Dimensions of Passenger Lifts and Service Lifts
(Clause 5.10.3.1)

All dimensions in millimetres.

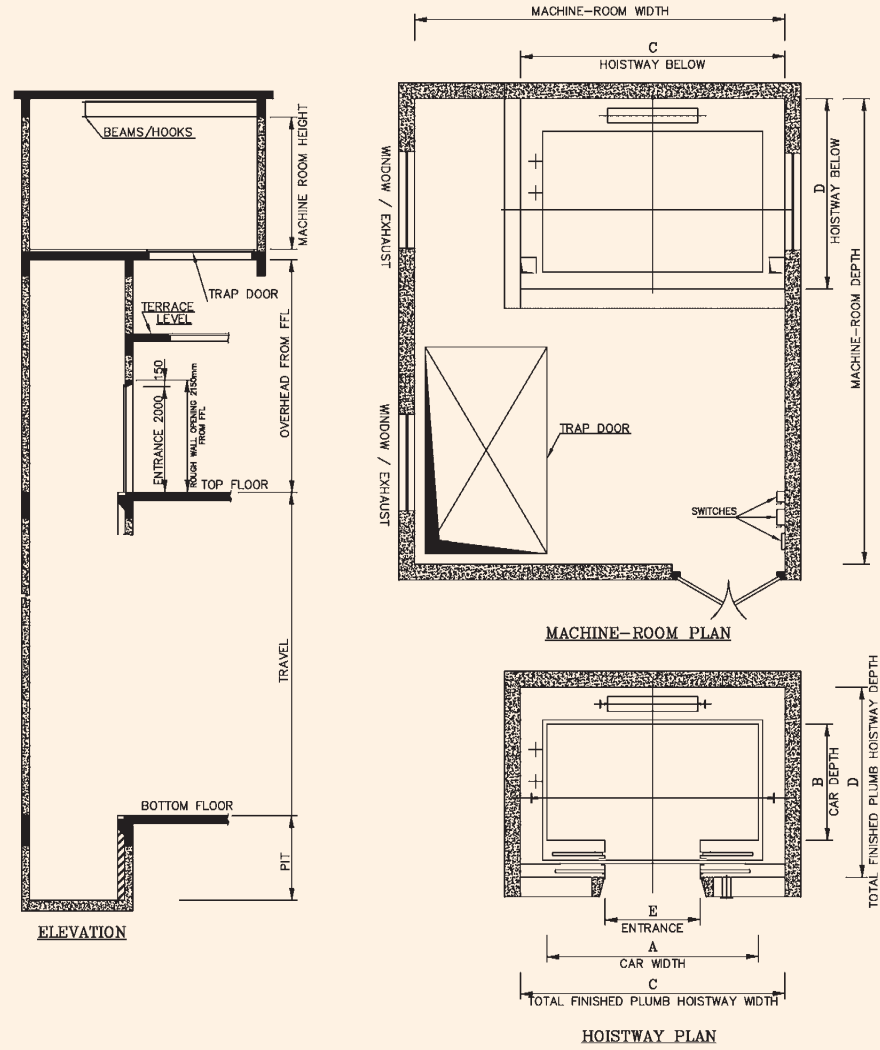

Table 12 — (Concluded)

Sl No.	No. of Passengers	Rated Load	Car Size		COPD Door	Passenger and Service Lifts with Machine Room: Shaft Sizes														
						Rated speed < 1 m/s		1.0 m/s ≤ Rated Speed ≤ 2.5 m/s		3.0 m/s ≤ Rated Speed ≤ 3.5 m/s		4.0 m/s ≤ Rated Speed ≤ 5.0 m/s		Rated Speed = 6.0 m/s		7.0 m/s ≤ Rated Speed ≤ 8.0 m/s		9.0 m/s ≤ Rated Speed ≤ 10.0 m/s		
						Shaft Size		Shaft Size		Shaft Size		Shaft Size		Shaft Size		Shaft Size		Shaft Size		
(1)	(2)	kg (3)	Width (4)	Depth (5)	Width (6)	Width (7)	Depth (8)	Width (9)	Depth (10)	Width (11)	Depth (12)	Width (13)	Depth (14)	Width (15)	Depth (16)	Width (17)	Depth (18)	Width (19)	Depth (20)	
i)	4	272	1 100	700	800	1 900	1 300	1 900	1 300											
ii)	6	408	1 100	1 000	800	1 900	1 700	1 900	1 700											
iii)	8	544	1 300	1 100	800	1 900	1 900	1 900	1 900											
iv)	10	680	1 300	1 350	800	1 900	2 150	1 900	2 150											
v)	13	884	2 000	1 100	900	2 600	1 900	2 600	1 900											
vi)	14	952	1 600	1 400	900	2 200	2 100	2 200	2 100	2 200	2 150	2 250	2 150	2 250	2 250	2 300	2 300	2 300	2 450	
vii)	16	1 088	1 600	1 600	1 000	2 300	2 300	2 300	2 300	2 300	2 350	2 300	2 350	2 300	2 450	2 300	2 500	2 300	2 650	
viii)	18	1 224	2 000	1 400	1 100			2 600	2 100	2 600	2 150	2 600	2 150	2 600	2 250	2 700	2 300	2 700	2 450	
ix)	20	1 360	2 000	1 500	1 100			2 600	2 100	2 600	2 250	2 600	2 250	2 600	2 350	2 700	2 400	2 700	2 550	
x)	22	1 496	2 100	1 600	1 100			2 700	2 300	2 700	2 350	2 700	2 350	2 700	2 450	2 800	2 500	2 800	2 550	
xi)	26	1 768	2 350	1 600	1 200			3 000	2 300	3 000	2 350	3 000	2 350	3 000	2 450	3 050	2 550	3 050	2 550	
xii)	29	1 972	2 350	1 700	1 200					3 000	2 500	3 000	2 500	3 000	2 550	3 050	2 600	3 050	2 700	

NOTES

1 All dimensions given above for lifts having centre opening power operated doors (COPD) with counterweight at rear, are recommended dimensions primarily for architects and building planners. Any variations mutually agreed between the manufacturer and the purchaser are permitted. However, variation in,

- a) car inside dimensions shall be within the minimum and maximum area limits specified in accordance with accepted standards [8-5A(6)].
- b) entrance width on higher side is permitted.
- c) entrance width on lower side is permitted up to 100 mm subject to minimum of 700 mm.

2 The minimum size of the lift car and all other requirements relating to accessibility, in all public buildings shall be in accordance with **13** of Part 3 'Development Control Rules and General Building Requirements' of the Code.

Table 13 Recommended Dimensions of Stretcher/Hospital Lifts

(Clause 5.10.3.1)

All dimensions in millimetres.

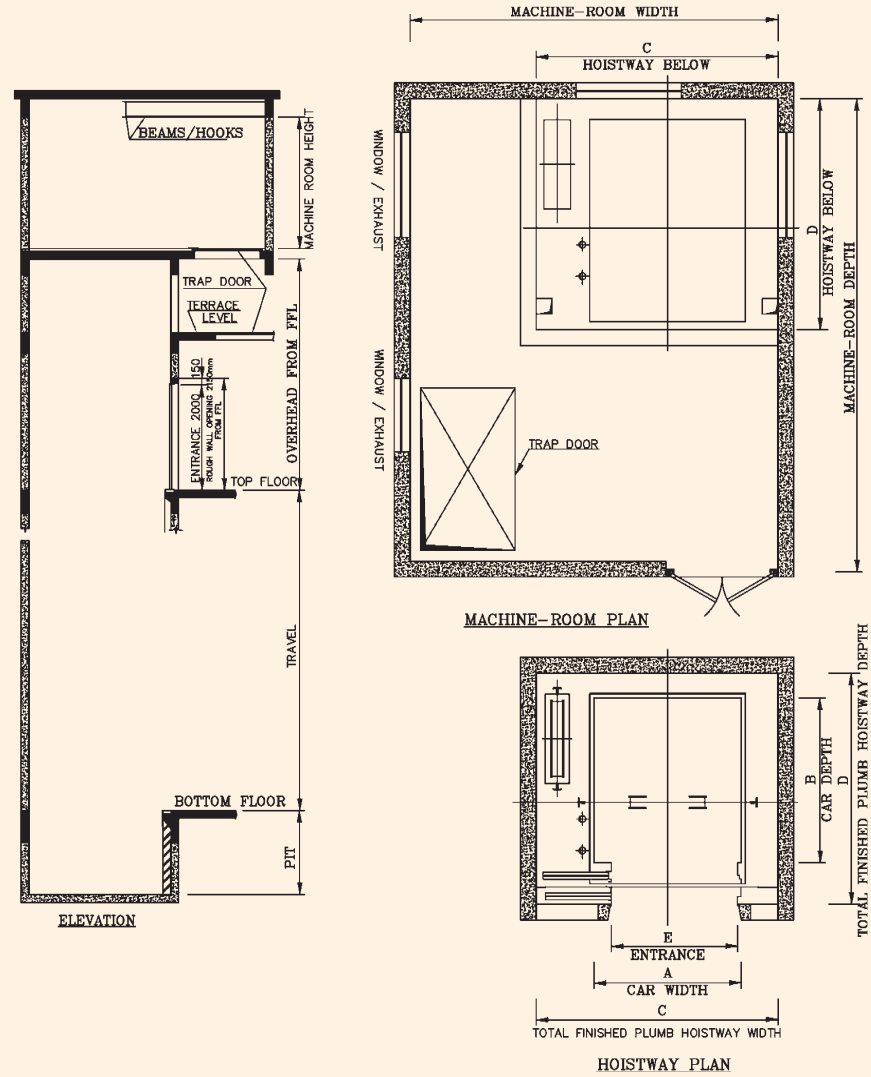

Table 13 — (Concluded)

Sl No.	No. of Passengers	Rated Load	Rounded off Rated Load	Car Size		2P TSPD Door	Hospital Bed / Stretcher Lifts with Machine Room: Shaft Sizes														
							Rated Speed ≤ 1 m/s		0.6 m/s ≤ Rated Speed ≤ 2.5 m/s		3.0 m/s ≤ Rated Speed ≤ 3.5 m/s		4.0 m/s ≤ Rated Speed ≤ 5.0 m/s		Rated Speed = 6.0 m/s		7.0 m/s ≤ Rated Speed ≤ 8.0 m/s		9.0 m/s ≤ Rated Speed ≤ 10.0 m/s		
							Shaft Size		Shaft Size		Shaft Size		Shaft Size		Shaft Size		Shaft Size		Shaft Size		
							Depth	Width	Depth	Width	Depth	Width	Depth	Width	Depth	Width	Depth	Width	Depth	Width	Depth
(1)	(2)	(3)	(4)	(5)	(6)	(7)	(8)	(9)	(10)	(11)	(12)	(13)	(14)	(15)	(16)	(17)	(18)	(19)	(20)	(21)	
i)	15	1 020		1 000	2 400	800	1 800	3 000	1 800	3 000											
ii)	20	1 360		1 300	2 400	1 200			2 300	3 000	2 350	3 000	2 350	3 000	2 350	3 000	2 500	3 000	2 500	3 000	
iii)	26	1 768	1 800	1 400	2 550	1 200			2 500	3 050	2 500	3 050	2 500	3 050	2 500	3 050	2 600	3 150	2 650	3 150	
iv)	29	1 972	2 000	1 500	2 700	1 400			2 650	3 200	2 600	3 200	2 600	3 200	2 600	3 200	2 700	3 200	2 700	3 200	
v)	36	2 448	2 500	1 800	2 700	1 400			2 800	3 150	2 900	3 200	2 900	3 200	2 900	3 200	3 000	3 200	3 000	3 200	

NOTES

- All dimensions given above for lifts having two panel telescopic doors (2P TSPD) with counterweight at side, are recommended dimensions primarily for architects and building planners. Any variations mutually agreed to between the manufacturer and the purchaser are permitted. However, variation in:
 - car inside dimensions shall be within the maximum area limits specified in accordance with accepted standards [8-5A(6)].
 - entrance width on higher side is permitted.
 - entrance width on lower side is permitted up to 100 mm subject to minimum of 700 mm.
- Car depth of 2 100 mm may be considered in residential/commercial buildings, where use of only ambulance stretcher is envisaged. The hoist-way depth maybe reduced accordingly.

Table 14 Recommended Dimensions of Goods Lifts with Machine Room

(Clause 5.10.3.1)

All dimensions are in millimetres.

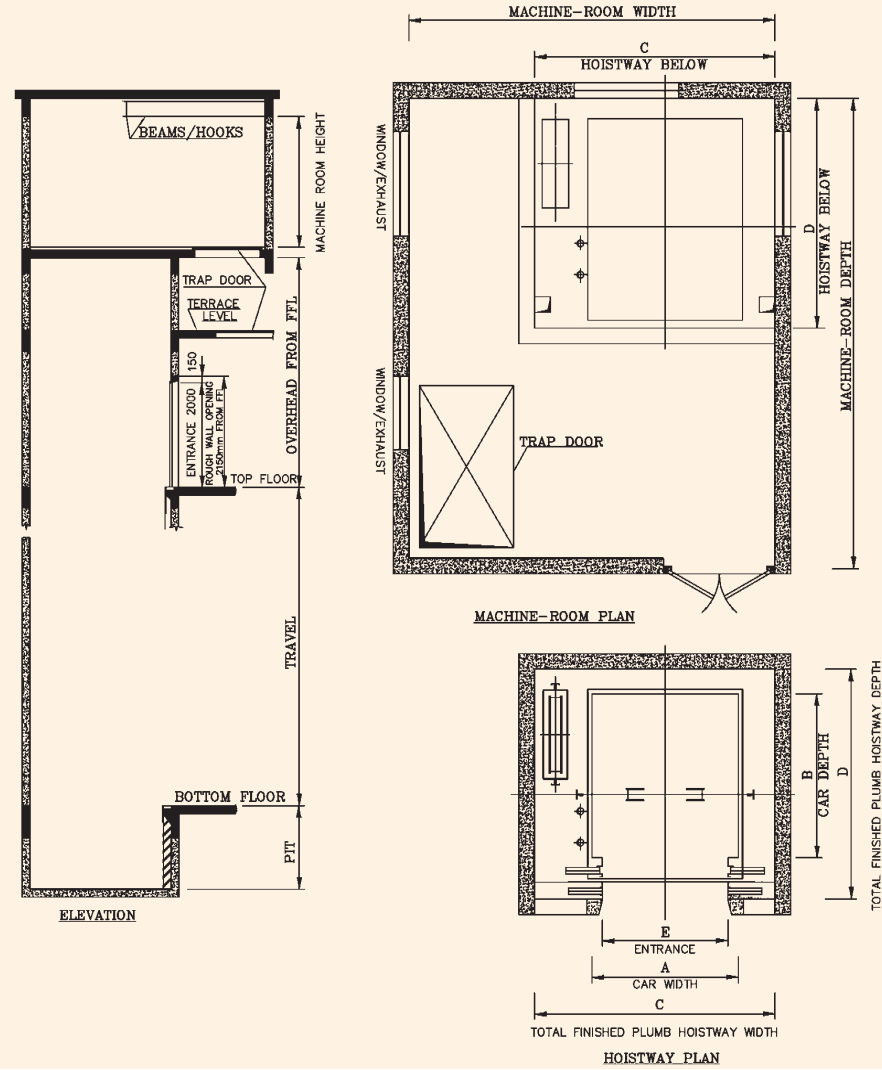

Table 14 — (Concluded)

Sl No.	Rated Load	Car Size		COPD Door	0.6 m/s ≤ Rated Speed ≤ 2.5 m/s		3.0 m/s ≤ Rated Speed ≤ 3.5 m/s		4.0 m/s ≤ Rated Speed ≤ 5.0 m/s		Rated Speed = 6.0 m/s		7.0 m/s ≤ Rated Speed ≤ 8.0 m/s		9.0 m/s ≤ Rated Speed ≤ 10.0 m/s	
		Shaft Size			Shaft Size		Shaft Size		Shaft Size		Shaft Size		Shaft Size			
		Width	Depth		Width	Depth	Width	Depth	Width	Depth	Width	Depth	Width	Depth	Width	
(1)	kg	(3)	(4)	(5)	(6)	(7)	(8)	(9)	(10)	(11)	(12)	(13)	(14)	(15)	(16)	(17)
i)	1 000	1 400	1 800	2P-tel-1200	2 300	2 350										
ii)	1 500	1 700	2 000	4P-1500	2 750	2 550										
iii)	2 000	1 700	2 500	4P-1500	2 800	3 050	2 800	3 050	2 900	3 050	3 000	3 050	3 000	3 050	3 000	3 050
iv)	2 500	2 000	2 500	4P-1700	3 000	3 050	3 000	3 050	3 100	3 050	3 200	3 050	3 200	3 050	3 200	3 050
v)	3 000	2 000	3 000	4P-1700	3 000	3 550	3 000	3 550	3 100	3 550	3 200	3 550	3 200	3 550	3 200	3 550
vi)	4 000	2 500	3 000	6P-2100	3 700	3 650	3 700	3 650								
vii)	5 000	2 500	3 600	6P-2100	3 850	4 250	3 850	4 250								

NOTE — All dimensions given above for lifts having centre opening power operated doors (COPD) with counterweight at side, are recommended dimensions primarily for architects and building planners. Any variations mutually agreed to between the manufacturer and the purchaser are permitted. However, the minimum rated load for the goods lift shall be based on a load of not less than 3.45 kN/m² of the net inside car area.

Table 15 Recommended Dimensions of Machine Room Height, Overhead, Pit Depth for Passenger, Goods, Stretcher/Hospital Lifts with Machine Room

(Clause 5.10.3.1)

All dimensions in millimetres.

For speed up to 3.5 m/s

Sl No.	No. of Passengers	Rated Load kg	Dimensions of Pit Depth, Overhead Height (HR) and Machine Room Height (MR)																					
			0.7 m/s			1.0 m/s			1.6 m/s			2 m/s			2.5 m/s			3 m/s			3.5 m/s			
			Pit Depth	HR	MR	Pit Depth	HR	MR	Pit Depth	HR	MR	Pit Depth	HR	MR	Pit Depth	HR	MR	Pit Depth	HR	MR	Pit Depth	HR	MR	
(1)	(2)	(3)	(4)	(5)	(6)	(7)	(8)	(9)	(10)	(11)	(12)	(13)	(14)	(15)	(16)	(17)	(18)	(19)	(20)	(21)	(22)	(23)	(24)	
i)	4	272	1 350	CH + 1 900	2 500	1 500	CH + 1 950	2 500	1 600	CH + 2 400	2 500	2 200	CH + 2 800	2 500										
ii)	6	408	1 350	CH + 1 900	2 500	1 500	CH + 1 950	2 500	1 600	CH + 2 400	2 500	2 200	CH + 2 800	2 500										
iii)	8	544	1 350	CH + 1 900	2 500	1 500	CH + 1 950	2 500	1 600	CH + 2 400	2 500	2 200	CH + 2 800	2 500										
iv)	10	680	1 350	CH + 1 900	2 500	1 500	CH + 1 950	2 500	1 600	CH + 2 400	2 500	2 200	CH + 2 800	2 500										
v)	13	884	1 350	CH + 1 900	2 500	1 500	CH + 1 950	2 500	1 600	CH + 2 400	2 500	2 200	CH + 2 800	2 500										
vi)	14	952				1 500	CH + 1 950	2 500	1 800	CH + 2 400	2 500	2 200	CH + 2 800	2 500	2 500	CH + 3 000	2 500	3 000	CH + 3 000	3 000	4 500	CH + 3 450	3 000	
vii)	16	1 088 / 1 000				1 500	CH + 1 950	2 500	1 800	CH + 2 400	2 500	2 200	CH + 2 800	2 500	2 500	CH + 3 000	2 500	3 000	CH + 3 000	3 000	4 500	CH + 3 450	3 000	
viii)	18	1 224				1 500	CH + 1 950	2 500	1 800	CH + 2 400	2 500	2 200	CH + 2 800	2 500	2 500	CH + 3 000	2 500	3 000	CH + 3 000	3 000	4 500	CH + 3 450	3 000	
ix)	20	1 360				1 500	CH + 1 950	2 500	1 800	CH + 2 400	2 500	2 200	CH + 2 800	2 500	2 500	CH + 3 000	3 000	3 000	CH + 3 000	3 000	4 500	CH + 3 450	3 000	
x)	22	1 496 / 1 500				1 500	CH + 1 950	2 500	1 800	CH + 2 400	3 000	2 200	CH + 2 800	3 000	2 500	CH + 3 000	3 000	3 000	CH + 3 000	3 000	4 500	CH + 3 450	3 000	
xi)	26	1 768				1 500	CH + 1 950	3 000	1 800	CH + 2 400	3 000	2 200	CH + 2 800	3 000	2 500	CH + 3 000	3 000	3 000	CH + 3 450	3 000	4 500	CH + 3 450	3 000	
xii)	29	1 972 / 2 000				1 600	CH + 1 950	3 000	1 800	CH + 2 400	3 000	2 200	CH + 2 800	3 000	2 500	CH + 3 000	3 000	3 000	CH + 3 450	3 000	4 600	CH + 3 450	3 000	
xiii)		2 500				1 800	CH + 1 950	4 000	1 800	CH + 2 400	4 000	2 200	CH + 2 800	4 000	2 500	CH + 3 000	4 000	3 000	CH + 3 450	4 000	4 600	CH + 3 450	4 000	
xiv)		3 000				1 800	CH + 1 950	4 000	1 800	CH + 2 400	4 000	2 200	CH + 2 800	4 000	2 500	CH + 3 000	4 000	3 200	CH + 3 450	4 300	4 600	CH + 3 600	4 300	
xv)		4 000				1 800	CH + 2 200	4 300	1 800	CH + 2 400	4 300	2 200	CH + 2 800	4 300	2 500	CH + 3 000	4 300	3 200	CH + 3 450	4 300	4 600	CH + 3 600	4 300	
xvi)		5 000				1 800	CH + 2 200	4 500	1 800	CH + 2 400	4 500	2 200	CH + 2 800	4 500	2 500	CH + 3 000	5 000	3 200	CH + 3 450	5 000	4 600	CH + 3 600	5 000	

Table 15 — (Concluded)

For speed from 4 m/s to 10 m/s

Sl No.	No. of Passengers	Rated Load	Passenger, Goods, Stretcher/Hospital Lifts With Machine Room: Dimensions of Pit Depth, Overhead Height (HR) and Machine Room Height (MR)																				
			4 m/s			5 m/s			6 m/s			7 m/s			8 m/s			9 m/s			10 m/s		
			Pit Depth	HR	MR	Pit Depth	HR	MR	Pit Depth	HR	MR	Pit Depth	HR	MR	Pit Depth	HR	MR	Pit Depth	HR	MR	Pit Depth	HR	MR
(1)	(2)	kg (3)	(4)	(5)	(6)	(7)	(8)	(9)	(10)	(11)	(12)	(13)	(14)	(15)	(16)	(17)	(18)	(19)	(20)	(21)	(22)	(23)	(24)
i)	14	952	4 600	CH + 3 450	4 000	4 700	CH + 3 450	4 000	5 500	CH + 3 800	4 300	5 900	CH + 5 000	4 300	6 500	CH + 5 800	4 300	7 100	CH + 6 500	5 000	7 500	CH + 6 900	5 000
ii)	16	1 088/1 000	4 600	CH + 3 450	4 000	4 700	CH + 3 450	4 000	5 500	CH + 3 800	4 300	5 900	CH + 5 000	4 300	6 500	CH + 5 800	4 300	7 100	CH + 6 500	5 000	7 500	CH + 6 900	5 000
iii)	18	1 224	4 600	CH + 3 450	4 000	4 700	CH + 3 450	4 000	5 500	CH + 3 800	4 300	5 900	CH + 5 000	4 300	6 500	CH + 5 800	4 300	7 100	CH + 6 500	5 000	7 500	CH + 6 900	5 000
iv)	20	1 360	4 600	CH + 3 450	4 000	4 700	CH + 3 450	4 000	5 500	CH + 3 800	4 300	5 900	CH + 5 000	4 300	6 500	CH + 5 800	4 300	7 100	CH + 6 500	5 000	7 500	CH + 6 900	5 000
v)	22	1 496/1 500	4 600	CH + 3 450	4 000	4 700	CH + 3 450	4 000	5 500	CH + 3 800	4 300	5 900	CH + 5 000	4 300	6 500	CH + 5 800	4 300	7 100	CH + 6 500	5 000	7 500	CH + 6 900	5 000
vi)	26	1 768	4 600	CH + 3 450	4 000	4 700	CH + 3 450	4 300	5 500	CH + 3 800	4 300	5 900	CH + 5 000	4 300	6 500	CH + 5 800	4 300	7 100	CH + 6 500	5 000	7 500	CH + 6 900	5 000
vii)	29	1 972/2 000	4 600	CH + 3 450	4 000	4 700	CH + 3 450	4 300	5 500	CH + 3 800	4 300	5 900	CH + 5 000	5 000	6 500	CH + 5 800	5 000	7 100	CH + 6 500	5 000	7 500	CH + 6 900	5 000
viii)		2 500	4 600	CH + 3 450	4 300	4 700	CH + 3 450	5 000	5 500	CH + 3 800	5 000	5 900	CH + 5 500	5 000	6 500	CH + 6 300	5 000	7 100	CH + 7 000	5 000	7 500	CH + 7 500	5 000
ix)		3 000	4 600	CH + 3 600	4 300	4 700	CH + 3 600	5 000	5 500	CH + 4 000	5 000	5 900	CH + 5 500	5 000	6 500	CH + 6 300	5 000	7 100	CH + 7 000	5 000	7 500	CH + 7 500	5 000

CH — Car clear inside height measured from car finished floor level to false ceiling.

NOTES

1 Recommended dimensions for pit depth, overhead and machine-room for different lift speeds are given in the table above. These dimensions may differ in practice as per individual manufacturer's design depending upon load, speed and drive. However, the pit depth and overhead shall be such as to conform to the requirements of bottom clearance and top clearance in accordance with the accepted standards [8-5A(7)].

2 In case of goods lifts minimum pit depth required is 1 600 mm.

3 In case of lift speeds 3.5 m/s and 4 m/s with rear counterweight the pit depth requirement could be less by about 500 mm to 1 000 mm.

Table 16 Recommended Dimensions of Automobile Lifts with Machine Room — Through Type Car (Rated Speed = 0.6 m/s or 1.0 m/s)

(Clause 5.10.3.1)

All dimensions in millimetres.

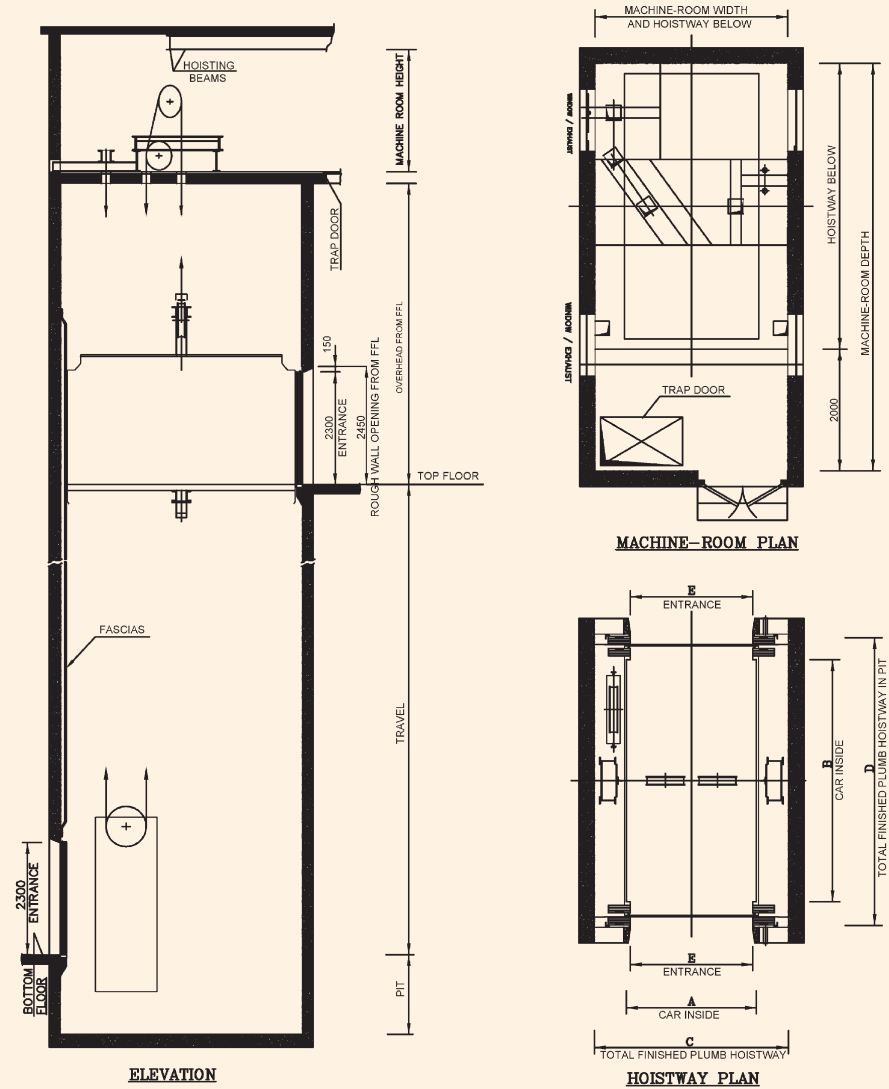

Table 16 — (Concluded)

Sl No.	Rated Load kg	Car Size		COPD Door Width	Shaft Size		Car Height CH	Overhead Height HR	Pit Depth PH	Machine Room Height MR
		Width	Depth		Width	Depth				
(1)	(2)	(3)	(4)	(5)	(6)	(7)	(8)	(9)	(10)	(11)
i)	2 500	2 500	5 300	4P-2 400	4 000	6 100			1 800	4 000
ii)	3 000	2 700	5 400	4P-2 400	4 000	6 200	2 400	5 200		
iii)	4 000	3 000	5 800	6P-3 000	4 300	6 700			2 000	4 500
iv)	5 000	3 000	6 000	6P-3 000	4 300	6 900				

NOTES

- 1 All dimensions given above for lifts having centre opening power operated doors (COPD) with counterweight at side, are recommended dimensions primarily for architects and building planners. Any variations mutually agreed to between the manufacturer and the purchaser are permitted. However, the minimum rated load for the automobile lift shall be based on a load of not less than 1.45kN/m² of the net inside car area.
- 2 Dimensions of machine room height, pit depth and overhead may differ in practice as per individual manufacturer's design depending upon load, speed and drive. However, the pit depth and overhead shall be such as to conform to the requirements of bottom clearance and top clearance in accordance with the accepted standards [8-5A(7)].
- 3 The lift car width should be selected such that in case of emergency while the automobile is in the car-lift the driver should be able to open the automobile door and come out of the automobile.

Table 17 Recommended Dimensions of Dumbwaiter Lifts

(Clause 5.10.3.1)

All dimensions in millimetres.

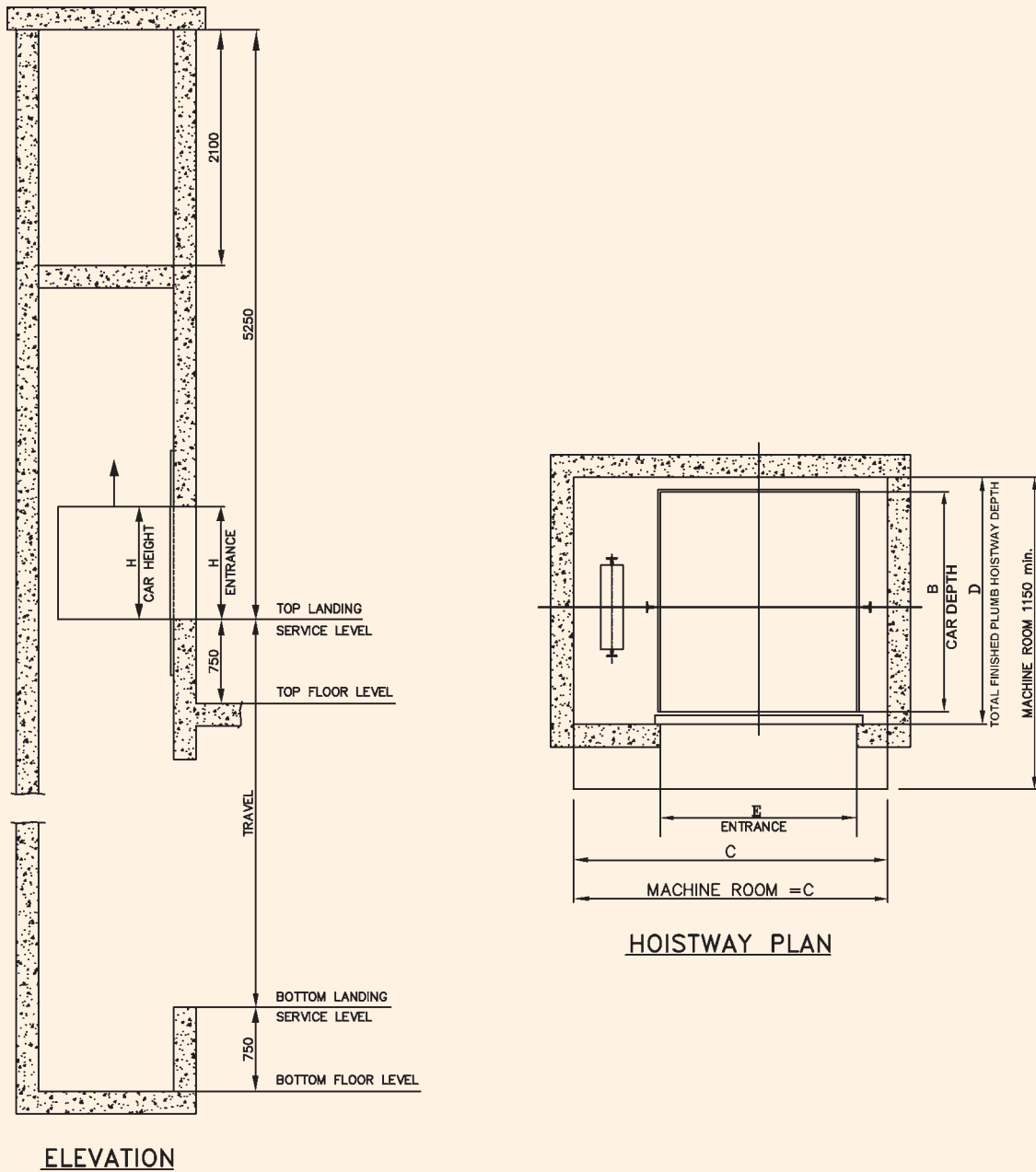

Sl No.	Load kg	Car Inside			Lift Well		Entrance E
		A	B	H	C	D	
(1)	(2)	(3)	(4)	(5)	(6)	(7)	(8)
i)	100	700	700	800	1 200	900	700
ii)	150	800	800	900	1 300	1 000	800
iii)	200	900	900	1 000	1 400	1 100	900
iv)	250	1 000	1 000	1 200	1 500	1 200	1 000

NOTE — Entrance width 'E' is based on assumption of provision of vertical biparting doors (no car door is normally provided).

Table 18 Recommended Dimensions of Passenger Lifts MRL COPD

(Clause 5.10.3.1)

All dimensions in millimetres.

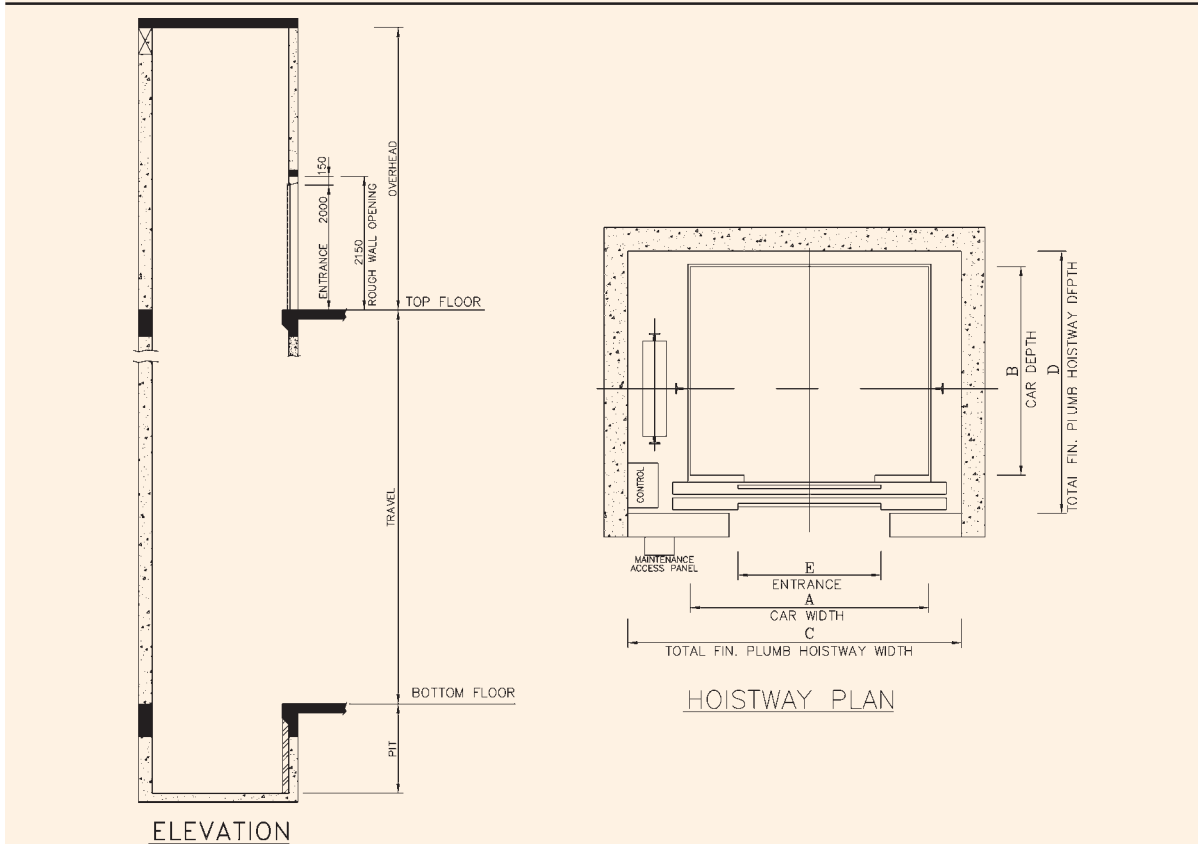

Sl No.	No. of Passengers	Rated Load	Car Size		2 P COPD Door	1.0 m/s ≤ Rated Speed ≤ 2.0 m/s		Rated Speed = 2.5 m/s		Rated Speed = 3.0 m/s	
			Width	Depth		Shaft Size		Shaft Size		Shaft Size	
(1)	(2)	(3)	(4)	(5)	(6)	(7)	(8)	(9)	(10)	(11)	(12)
i)	4	272	900	850	700	1 600	1 550				
ii)	6	408	1 000	1 100	800	2 000	1 700				
iii)	8	544	1 300	1 100	800	2 150	1 800				
iv)	10	680	1 350	1 300	800	2 150	1 900				
v)	13	884	1 600	1 400	1 000	2 550	1 950	2 550	2 050	2 550	2 250
vi)	15	1 020	1 600	1 550	1 000	2 550	2 050	2 550	2 150	2 550	2 250
vii)	16	1 088	1 600	1 600	1 000	2 550	2 100	2 550	2 200	2 550	2 300
viii)	20	1 360	1 800	1 700	1 100	2 700	2 300	2 700	2 350	2 700	2 350
ix)	22	1 496	1 800	1 900	1 100	2 700	2 400	2 750	2 450	2 750	2 450
x)	26	1 768	1 900	2 000	1 100	2 800	2 450	2 850	2 450	2 850	2 500
xi)	29	1 972	2 350	1 700	1 200	3 100	2 200	3 100	2 200		

NOTES

1 All dimensions given above for lifts having centre opening power operated doors (COPD) with counterweight at side, are recommended dimensions primarily for architects and building planners. Any variations mutually agreed to between the manufacturer and the purchaser are permitted. However, variation in,

- a) car inside dimensions shall be within the maximum area limits specified in accordance with accepted standards [8-5A(6)].
- b) entrance width on higher side is permitted.
- c) entrance width on lower side is permitted up to 100 mm subject to minimum of 700 mm.

2 The minimum size of the lift car and all other requirements relating to accessibility, in all public buildings shall be in accordance with 13 of Part 3 'Development Control Rules and General Building Requirements' of the Code.

Table 19 Recommended Dimensions of Stretcher/Hospital lifts MRL (2P Telescopic Door/4P COPD, Speed 1.0 m/s to 2.0 m/s)

(Clause 5.10.3.1)

All dimensions in millimetres.

Sl No.	Rated Load		Car Size		Door Size	Shaft Size	
	Persons	kg	Width	Depth		Width	Depth
(1)	(2)	(3)	(4)	(5)	(6)	(7)	(8)
i)	15	1 020	1 100	2 400	900	2 150	2 950
ii)	20	1 360	1 300	2 400	1 200	2 350	2 950
iii)	23	1 600	1 400	2 400	1 300	2 450	2 950
iv)	29	2 000	1 500	2 700	1 300	2 450	3 250

NOTES

1 All dimensions given above for lifts having 2 panel telescopic or 4 panel centre opening power operated doors (4P COPD) with counterweight at side, are recommended dimensions primarily for architects and building planners. Any variations mutually agreed to between the manufacturer and the purchaser are permitted. However, variation in,

- i) car inside dimensions shall be within the maximum area limits specified in accordance with accepted standards [8-5A(6)].
- ii) entrance width on higher side is permitted.
- iii) entrance width on lower side is permitted up to 100 mm subject to minimum of 700 mm.

2 Car depth of 2 100 mm may be considered in residential/commercial buildings where use of only ambulance stretcher is envisaged. The hoist-way depth maybe reduced accordingly.

Table 20 Pit Depth for Passenger/Stretcher/Hospital Lifts MRL

(Clause 5.10.3.1)

All dimensions in millimetres.

Sl No.	No. of Passengers	Pit Depth for Speed					
		1 m/s	1.6 m/s	1.8 m/s	2 m/s	2.5 m/s	3 m/s
(1)	(2)	(3)	(4)	(5)	(6)	(7)	(8)
i)	4	1 600	1 800	2 000	2 200		
ii)	6	1 600	1 800	2 000	2 200		
iii)	8	1 600	1 800	2 000	2 200		
iv)	10	1 600	1 800	2 000	2 200		
v)	13	1 600	1 800	2 000	2 200	2 500	3 100
vi)	15	1 600	1 800	2 000	2 200	2 500	3 100
vii)	16	1 600	1 800	2 000	2 200	2 500	3 100
viii)	20	1 800	1 800	2 000	2 200	2 500	3 100
ix)	22	1 800	1 800	2 000	2 200	2 500	3 100
x)	26	1 800	1 800	2 000	2 200	2 500	3 100
xi)	29	1 800	1 800	2 000	2 200	2 500	

NOTE — Recommended dimensions for pit depth for different lift speeds are given in the table. These dimensions may differ in practice as per individual manufacturer’s design depending upon load, speed and drive. However, the pit depth shall be such as to conform to the requirements of bottom clearance and top clearance in accordance with the accepted standards [8-5A(7)].

Table 21 Overhead Height for Passenger and Stretcher/Hospital Lifts MRL

(Clause 5.10.3.1)

All dimensions in millimetres.

Sl No.	No. of Passengers	For Speed			
		1 m/s	1.6 m/s ≤ Rated Speed ≤ 2 m/s	2.5 m/s	3 m/s
(1)	(2)	(3)	(4)	(5)	(6)
i)	4	CH + 1 900	CH + 2 400		
ii)	6	CH + 1 900	CH + 2 400		
iii)	8	CH + 1 900	CH + 2 400		
iv)	10	CH + 1 900	CH + 2 400		
v)	13	CH + 1 900	CH + 2 400	CH + 2 600	CH + 2 800
vi)	15	CH + 1 900	CH + 2 400	CH + 2 600	CH + 2 800
vii)	16	CH + 1 900	CH + 2 400	CH + 2 600	CH + 2 800
viii)	20	CH + 1 900	CH + 2 400	CH + 2 600	CH + 2 800
ix)	22	CH + 1 900	CH + 2 400	CH + 2 600	CH + 2 800
x)	26	CH + 1 900	CH + 2 400	CH + 2 600	CH + 2 800
xi)	29	CH + 1 900	CH + 2 400	CH + 2 600	

NOTE — Recommended dimensions for overhead for different lift speeds are given in the table. These dimensions may differ in practice as per individual manufacturer’s design depending upon load, speed and drive. However, the overhead shall be such as to conform to the requirements of bottom clearance and top clearance in accordance with the accepted standards [8-5A(7)].

Table 22 Recommended Dimensions of Goods Lifts MRL (Speed 1.0 m/s)

(Clause 5.10.3.1)

All dimensions in millimetres.

Sl No.	Rated Load	Car Size		Door Size	Telescopic Door		4P COPD		2P COPD		Overhead Height	Pit Depth
		Width	Depth		Shaft Size		Shaft Size		Shaft Size			
				kg	Width	Depth	Width	Depth	Width	Depth	Width	Depth
(1)	(2)	(3)	(4)	(5)	(6)	(7)	(8)	(9)	(10)	(11)	(12)	(13)
i)	500	1 300	1 100	800					1 950	1 800	CH + 1 900	1 600
ii)	1 000	1 600	1 550	1 000					2 250	2 050	CH + 1 900	1 600
iii)	1 600	1 400	2 400	1 300	2 550	3 000	2 500	3 000			CH + 1 900	1 800
iv)	2 000	1 500	2 700	1 300	2 550	3 300	2 550	3 300			CH + 1 900	1 800
v)	2 500	1 800	2 650	1 700			3 150	3 250			CH + 2 100	1 800
vi)	3 000	2 000	2 700	1 800			3 350	3 300			CH + 2 100	1 800
vii)	4 000	2 100	3 400	1 800			3 400	4 000			CH + 2 100	2 100
viii)	5 000	2 500	3 500	2 200			3 800	4 100			CH + 2 400	2 200

NOTES

1 CH is the clear car height from car finished floor level to car roof (goods lifts will normally not have any false ceiling).

2 Normal range for CH is 2 100 mm to 2 400 mm.

3 Door height is less than or equal to the car height CH.

4 In case counterweight safety is applicable check for dimensions with lift manufacturer.

5 All dimensions given above for lifts having telescopic or centre opening power operated doors (COPD) with counterweight at side, are recommended dimensions primarily for architects and building planners. Any variations mutually agreed to between the manufacturer and the purchaser are permitted. However, the minimum rated load for the goods lift shall be based on a load of not less than 3.45 kN/m² of the net inside car area.

6 Recommended dimensions for overhead and pit depth for different lift speeds are given in the table. These dimensions may differ in practice as per individual manufacturer’s design depending upon load, speed and drive. However, the overhead and pit depth shall be such as to conform to the requirements of bottom clearance and top clearance in accordance with the accepted standards [8-5A(7)].

Table 23 Recommended Dimensions of Automobile Lifts MRL COPD (Speed 0.5 m/s to 1.0 m/s)

(Clause 5.10.3.1)

All dimensions in millimetres.

Sl No.	Rated Load kg	Car Size		6P COPD Door Size: Opposite Entrances	Shaft Size		Overhead Height	Pit Depth
		Width	Depth		Width	Depth		
(1)	(2)	(3)	(4)	(5)	(6)	(7)	(8)	(9)
i)	3 000	2 500	5 500	2 200	3 800	6 450	4 850	2 500
ii)	4 000	3 000	6 000	2 700	4 300	6 950	4 850	2 500

NOTES

- 1 Car height normal range is 2 100 mm to 2 700 mm.
- 2 Overhead height shown is required for all values of car height CH shown above.
- 3 In case counterweight safety is applicable check for dimensions with lift manufacturer.
- 4 All dimensions given above for machine room less lifts with 6 panel centre opening power doors (6P COPD) used for automobiles are recommended dimensions for architects and building planners. Any variations mutually agreed to between the manufacturer and the purchaser are permitted. However, the minimum rated load for the automobile lift shall be based on a load of not less than 1.45kN/m² of the net inside car area.
- 5 Dimensions of pit depth and overhead may differ in practice as per individual manufacturer’s design depending upon load, speed and drive. However, the pit depth and overhead shall be such as to conform to the requirements of bottom clearance and top clearance in accordance with the accepted standards [8 5A(7)].
- 6 The lift car width should be selected such that in case of emergency while the automobile is in the lift car the driver should be able to open the automobile door and come out of the automobile.

- c) *General requirements related to the lift well* — The well shall be exclusively used for lifts. It shall not contain cables or devices, etc other than for the lift. Permanently installed adequate lighting shall be provided comprising sufficient number of lamps fixed throughout the lift well such that the illumination level 1 m above the car roof within its vertical projection at any position of the car in the well and 1 m above pit floor everywhere a person can stand, work and/or move between the working areas shall be at least 50 lux and at least 20 lux at remaining locations, even when all the doors are closed.

NOTE — Additional lamps may be fixed on the car top as a part of the well lighting system to achieve this.

Well lighting switch shall be located in the machine room close to the main switch and pit lighting switch in lift well close to lower landing door.

Should a lift entrance open out in to an area exposed to the weather, the entrance should be protected by a suitable canopy and the ground level sloped up to the lift entrance to prevent rain or drainage water entering the lift well through the clearances around the landing doors. Any push buttons exposed should be of weatherproof type.

The approach of the landing door on each floor shall be kept lighted during the whole time the lift is available for use at night, and during the day time if so required due to insufficient natural light.

When the distance between consecutive landing door sills exceeds 11 000 mm, intermediate emergency landing(s) with lift landing door(s) shall be provided such that the distance between any two consecutive landings is not more than 11 000 mm. Rescue through these landings is permissible in case of automatic rescue device operation.

No counter-weight shall be allowed to travel in any lift well, or part of any lift well other than that to which it belongs.

In the case of a lift well which is common to more than one lift and where the lift car or the counterweight of one lift is working in juxtaposition to the lift car or counterweight of another lift, such lift cars or counterweights shall be guarded carefully and adequately in order to protect persons working in the lift well or on the lift cars from accidental contact with such cars or counterweights in any part of their travel.

- d) *Construction of the lift well* — The side walls of the lift well may be made of reinforced cement concrete at least 150 mm thick; or brick or similar fire resisting materials

provided tie beams are made available for lift guide rail fixings at such heights as specified by the lift manufacturer, so as to provide satisfactory anchoring arrangement for fixing guide rails and other equipment to the lift well. The inner surface of the lift well and its enclosure facing any lift-car entrance shall, so far as practicable, be kept smooth and flush devoid of projections or recesses. Where any projections or tops of the recesses cannot be rendered flush, they shall be levelled on the underside to an angle not less than 60° from the horizontal, by means of metal plates, cement rendering or other fire resisting material.

Where a lift car levelling device is operative with the lift car door open, such interior surfaces shall always form a smooth and flush surface below each landing level for a depth to at least the depth of the car-levelling zone plus the distance through which the lift car may travel of its own momentum when the power is cut-off.

The distance between the lift well enclosure on the sides facing any lift-car entrance and the sill edge of the car shall not be more than 30 mm in the landing zone below the landing gate. If such distance is more than 30 mm in the lift well enclosure, the same shall be finished with suitable and smooth plaster work or fascia plates so as to make the surface thereof devoid of all projections and recesses. In case the enclosure wall on the sides facing the lift-car entrance is more than 130 mm from the sill edge of the lift-car platform, the lift-car door of such lift shall be provided with means to prevent it from being opened except when the lift-car is at the landing served by such car entrance.

Sufficient space shall be provided between the guides for the car and the side walls of the lift well enclosure to allow safe and easy access to the parts of the safety gears for their maintenance and repairs.

All landing openings shall be protected by gates or doors which shall extend to the full height and full width of the landing openings. These openings shall not be less than 2 000 mm in clear height and 700 mm clear in width when the gates or doors are fully opened. There shall not be any common wall between lift well and water tank.

- e) *Strength of the walls of the well* — The structure of the well shall be able to support at least the loads which may be applied by the

machine, by the guide rails at the moment of safety gear operation, by eccentric load in the car, by the action of buffers, by the application of anti-rebound devices, by loading and unloading the car, etc.

The walls of the well shall withstand a force of 1 000 N, being evenly distributed over an area of 900 cm² in round or square section and applied at right angles to the wall at any point on either face,

- 1) without permanent deformation greater than 1 mm; and
- 2) without elastic deformation greater than 15 mm.

Glass panels, plane or formed shall be made of laminated glass. Such panels and their fixings shall withstand horizontal static force of 1 000 N applied on an area of 900 cm² at any point, from either side, without permanent deformation.

- f) *Partition walls between lifts in a common lift well* — In case of common lift well for multiple lifts, the partition wall(s) of the common lift well may be either be RCC or brick or steel or glass which may be provided with openings for escape of air displaced due to movement of lift in the adjacent well. For high speed lifts the partition between the lifts may be of suitable wire grill / expanded metal of following specifications:

- 1) It shall be made of at least 2.2 mm thick steel wire or expanded metal.
- 2) A ball of 25 mm diameter shall not pass through the wire grill.
- 3) It shall be so fixed as not to deflect more than 15 mm when subjected to a force of 450 N applied horizontally at any point from either side.

6.1.2 Requirements of the Pit

Pit shall be soundly constructed and maintained in a dry (water proofed) and clean condition. Where necessary, provision shall be made for permanent drainage. The floor of the pit shall be able to support beneath each guide rail, force due to mass of guide rails plus the reaction due to safety gear operation. The floor of the pit shall be able to support beneath the car buffer supports, force in Newton, equal to 4 times the static load being imposed by the mass of fully loaded car:

$$4.g (P + Q)$$

where

P = mass of empty car and components supported by the car, that is part of travelling

cable, compensating rope/chain, if any, etc, in kg;

Q = rated load, in kg; and

g = acceleration due to gravity.

The floor of the pit shall be able to support beneath the counterweight buffer support, force in Newton, equal to 4 times the static load being imposed by the mass of the counterweight:

$$4.g (P + q.Q)$$

where

P = mass of empty car and components supported by the car, that is part of travelling cable, compensating rope/chain, if any, etc, in kg;

Q = rated load, in kg;

g = acceleration due to gravity; and

q = live load balancing factor (normally, $q = 0.5$).

The floor of the pit shall be able to support upward thrust of the tied down rope compensation device, if provided. If accessible spaces do exist below the well, the base of the pit shall be designed for an imposed load of at least 5 000 N/m² and the counterweight shall be equipped with safety gear. In addition, it is recommended to provide double slab for the lift pit.

NOTES

1 Lift wells should preferably not be situated above a space accessible to persons.

2 Enclosing projected area of the lift shaft under the pit in accessible spaces will not nullify above provisions.

There shall not be any common wall/slab between lift pit and any water reservoir.

The pit shall be accessible by an access door. A permanent ladder inside the well may be provided close to the last landing *in-lieu* of access door, if the pit depth does not exceed 2.5 m.

NOTE — In case of structural limitations for providing pit access door at pit floor level, alternative arrangement to access pit may be provided which shall allow access to pit with complete safety.

A physical means of protection shall be provided to prevent accidental contact with the counterweight.

The pit shall be equipped with a stop switch which is easily accessible from the lowest landing and the pit floor. If more than one switch is required, they shall be wired in series.

6.1.3 Requirements Associated with Machine Room and Pulley Room

Generally lifts have machine rooms immediately over the lift well, and this should be arranged, whenever

possible without restricting the overhead distance required for normal safety precautions. In case where machine room provision on top is a limitation, either machine room less lift or basement drive or side drive lift can be considered. The spaces and tolerances shall be in accordance with the following:

a) *Requirements associated with machine room and pulley room (where lift machinery is placed in the machine room)*

- 1) The lift machine, controller and all other apparatus and equipment of a lift installation, except such apparatus and equipment having functional location in the lift well or other positions, shall be placed in the machine room which shall be adequately lighted and rendered fire-resistant and weather-proof.

If parts of different lifts are present in one machine and/or pulley room each lift shall be identified with a number, letter or colour consistently used for all parts (machine, controller, over speed governor, switches, etc).

- 2) Machine room should be considered as plant space, and conditions provided to permit reliable operation of electrical switchgear and rotating machinery, and be conducive to good maintenance. The machine room shall be either air conditioned or adequately ventilated so as to maintain the ambient temperature therein between +5°C and +40°C. The machine room shall be such that the motors and equipment as well as electric cables etc are protected as far as possible from dust and humidity. Machine room should also be protected from all weather and if ventilation louvers are provided, they should be designed and located to prevent entry of rain water in the machine room.

The well, machinery spaces and pulley rooms shall not be used to provide ventilation of rooms other than those belonging to the lift.

- 3) Rescue instructions with required tools and tackles, if any, shall be made available in the machine room.
- 4) Machine room floor shall be provided with a trap door, if necessary. The size of the trap door shall be as per manufacturer's recommendation. Since the purpose of the trap door is to lift or lower the machinery, controller, etc, between machine room and the top landing, it may be necessary to provided similar trap door in the terrace slab as well depending on the design of the building.

The trap door when closed shall be able to support 2 000 N on an area of 0.20 m × 0.20 m

at any position. The trap door shall not open downwards. Hinges, if any, shall be of a type which cannot be unhooked. Trap doors shall be locked. When the trap door is in the open position, precautions shall be taken to prevent the fall of persons (for example, a guardrail) and prevent the trapdoor from closing such as to cause a crushing hazard (for example by counterbalance).

- 5) Lighting shall be provided to give at least 200 lux around the controller and machine. At least one plug socket point per lift shall be provided in the machine room. The switch for the machine room light shall be fixed near the entrance of the machine room. The machine room walls, ceiling and floor should be finished in dust-resisting materials, tiles, etc, or painted as a minimum to stop dust circulation, which otherwise could damage rotating machinery and cause failure of switchgear.
- 6) The machine room shall be so designed as to allow free and easy access to all parts of the equipment and the width of the clear space around the machine from any two sides shall in no case be less than 600 mm. Provision shall be made to allow the removal and replacement of various units. The entrance of the machine room shall be minimum 1 m wide and 2 m high to allow removal and replacement of machinery therein. The floor of the machine room shall be designed and constructed to carry safely at any point the heaviest part of the equipment and withstand the loads and forces to which they are intended to be subjected to. If the floor does not extend to the enclosing wall, the open sides shall be adequately guarded by suitable means for example, rails, guards.
- 7) The height of the machine room shall be sufficient to allow any portion of the equipment to be accessible and removable for repairs and replacement and shall not be less than 2 000 mm clear from the floor of the access area and working area. There shall be a clear vertical distance of at least 300 mm above the rotating parts of the machine.
- 8) The machine room shall be locked and shall be accessible to those who are concerned with the operation and maintenance of the machinery or equipment. Approach way to machine room from top landing level shall be direct, easy and safe to walk by way of stairs. If stairs are not possible, sufficiently wide and deep permanent structural steps may be used.

These structural steps shall be provided with adequate hand holds and shall not be too steep.

- 9) A danger notice board shall be displayed permanently on the outside of the machine room door and near the machinery.
- 10) There shall not be any common wall/slab between machine room and any water reservoir.
- 11) The machine room shall not be used as a store room or for any purpose other than housing the machinery/components connected with the lift installation. The machine room shall not act as a passage to any other room or utility. The lift well, machine and pulley rooms may, however contain,
 - i) equipment for air conditioning or heating of these spaces, excluding steam heating and high pressure water heating. However, any control and adjustment devices of the heating apparatus shall be located outside the well.
 - ii) fire detectors and/or suppression system, with a high operating temperature, appropriate for the electrical equipment and suitably protected against accidental impact.

When sprinkler systems are used, activation of the sprinkler shall only be possible, when the lift is stationary at a landing and the electrical supply of the lift and lighting circuits are automatically switched off by the fire or smoke detection system.

NOTE — Such smoke, fire detection and sprinkler systems are the responsibility of the building management.
- 12) Machine room floor shall be designed to carry an imposed (live) load of not less than 10 kN/m² over the whole area and also any load which may be imposed thereon by the equipment used in the machine room or by any reaction from any such equipment both during periods of normal operation, maintenance and repair.
- 13) One or more beams or hooks with the indication of the safe working load, as appropriate, shall be provided in the machinery spaces, and conveniently positioned to permit the hoisting of heavy equipment.
- 14) The total load on overhead beams used for supporting machinery shall be assumed as equal to all equipment resting on the beams plus twice the maximum load suspended from the beams.

- 15) The factor of safety for all overhead beams and supports based on ultimate strength of the material and load in accordance with (14) shall be not less than the following:

- i) For steel : 5
ii) For reinforced concrete : 7

The deflection of the overhead beams under the maximum static load calculated in accordance with above shall not exceed 1/1 500 of the span.

- 16) The place in which the overhead pulleys, over speed governors and similar machinery are fixed shall be easily accessible for maintenance and repair purposes. It shall be lighted adequately and safe working procedure shall be established for maintenance and repair works.
- 17) It is recommended that emergency exit is provided in case of large machine rooms having four or more lifts.
- 18) Where the machine room occupies a prominent position on roof of a building, provision should be made for lightning protection in accordance Part 8 'Building Services, Section 2 Electrical and Allied Installations' of the Code and applicable standards.

b) Requirements associated with machine spaces (where machinery is placed in the well)

- 1) Access to the interior of the machinery and pulley spaces shall be capable of being properly lit by a permanent electric light fixture(s) and easy to use in complete safety in all circumstances without necessitating entry into private premises.
- 2) Machinery spaces inside the well shall be designed and constructed to withstand the loads and forces they are subjected to.
- 3) In the case of partially enclosed wells located at the exterior of the building, the machinery shall be suitably protected against environmental influences.
- 4) Provision should be given to access the machine for maintenance purpose either from car top or otherwise
- 5) The clear height for movement shall not be less than 2 m.
- 6) The machinery spaces shall be suitably ventilated. The electric equipment of the machinery shall be protected as far as it is reasonably practicable from dust, harmful fumes and humidity.
- 7) The working area and machinery spaces shall

be provided with permanently installed electric lighting on the basis of at least 200 lux at floor level.

- 8) One or more beams or hooks with the indication of the safe working load, as appropriate, shall be provided in the machinery spaces, conveniently positioned to permit the hoisting of heavy equipment.
- 9) The total load on overhead beams used for supporting machinery shall be assumed as equal to all equipment resting on the beams plus twice the maximum load suspended from the beams.
- 10) The factor of safety for all overhead beams and supports based on ultimate strength of the material and load in accordance with (9) shall be not less than the following:

- i) For steel : 5
ii) For reinforced concrete : 7

The deflection of the overhead beams under the maximum static load calculated in accordance with above shall not exceed 1/1 500 of the span.

c) Requirements associated with machine spaces (where machinery is placed outside of the well)

- 1) Machinery spaces outside of the well shall be constructed to withstand the loads and forces to which they are subjected.
- 2) The total load on beams used for supporting machinery shall be assumed as equal to all equipment resting on the beams plus twice the maximum load suspended from the beams.
- 3) The factor of safety for all beams and supports based on ultimate strength of the material and load in accordance with (2) above shall be not less than the following:
 - i) For steel : 5
 - ii) For reinforced concrete : 7

The deflection of the overhead beams under the maximum static load calculated in accordance with above shall not exceed 1/1 500 of the span.

- 4) Access to the interior of the machinery and pulley spaces shall be,
 - i) capable of being properly lit by a permanent electric light fixture(s); and
 - ii) easy to use in complete safety in all circumstances without necessitating entry into private premises.

The clear height for movement shall not be less than 2 m.
- 5) The machinery shall be located inside a

cabinet consisting of imperforate walls, floor, roof and lockable door(s).

- 6) The machinery cabinet shall be suitably ventilated. It shall be such that the machinery is protected as far as it is reasonably practicable from dust, harmful fumes and humidity.
- 7) The inside of the machinery cabinet shall be provided with permanently installed electric lighting on the basis of at least 200 lux at floor level. The switch placed inside close to the door(s), at an appropriate height, shall control lighting of the cabinet.

d) *Dimensional tolerances*

- 1) *Lift well dimensions* — Plan dimensions of lift wells given by the lift manufacturer represent the minimum clear plumb sizes. The purchaser’s representative, in conjunction with the builder, should ensure that adequate tolerances are included in the building design so that the specified minimum plumb dimensions are obtained in the finished work. Dimensions in excess of these minimum plumb dimensions for lift well and openings (but not less) can be accommodated by the lift manufacturer up to certain maximum values beyond which changes in design may be necessary involving additional expense or work by the builder. The purchaser’s representative should take these factors into account when specifying the lift well structural dimensions on the basis of the constructional tolerance appropriate to the building technique.
- 2) *Landing door openings* — It is very important that finished landing openings should be accurate to design size and plumb one above the other for the full travel of the lift. In constructing the structural openings in concrete walls to lift wells it is not possible to achieve a degree of accuracy vertically which will allow doors and frames to be inserted in the opening without some form of masking or packing to overcome inaccuracies. Provisions should therefore be made in design by increasing the nominal height from design finished floor level and width of openings to each jamb and head. In addition, the alignment of the outer face of the front wall of the lift well is of importance when architrave of fixed dimensions are called for, and in this case the alignment of the outer face from floor to floor should not vary to a greater extent than can be accommodate by the subsequent front wall

finish, the architrave being set accurately plumb.

- 3) *Structural limits for lift wells at any level* — If the net plumb well (dimensions *A* and *B* in Fig. 3) and the nominal structural entrance openings (dimensions *C* and *D* in Fig. 3) are defined by plumb lines, the actual wall should not encroach on these dimensions.

Dimension *K* (inside face of wall of Fig. 3) should fall within the following limits:

- i) For wells up to 30 m : 0 - 25 mm
- ii) For wells up to 60 m : 0 - 35 mm
- iii) For wells up to 100 m : 0 - 50 mm
- iv) For wells taller than 100 m : 0 - 50 mm for portion of the well.

When architraves are to be supplied by the lift manufacturer dimension *L* (side of structural opening of Fig. 3) should fall within the limits of 0 and 25 mm and dimension *M* (outer face of the front wall of Fig. 3) should not vary to a greater extent than can be accommodated by the subsequent front wall finish, the architrave being set accurately plumb. When the entrance linings are supplied by the builder, corresponding provision should be made for the finished openings to be accurately plumb one above the other for the full travel of the lift end to design size.

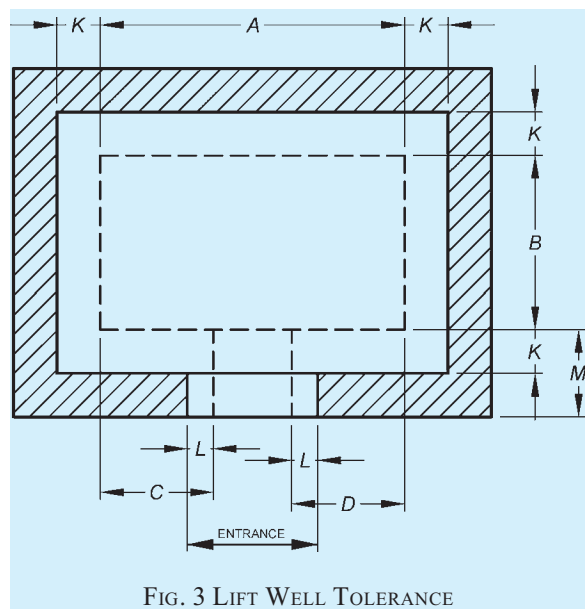

6.2 Electrical Installation Requirements

The lift manufacturer should specify, on a schedule, particulars of full load current, starting current, maximum permissible voltage drop, size of switches

and other details to suit requirements. The main power cable and lighting cable shall be routed through respective lift shaft for every lift. It is important that the switches at the intake and in the machine room which are provided by the electrical contractor are of correct size. No form of 'NO VOLT' trip relay should be included anywhere in the power supply of the lift.

6.2.1 Main Switches

For each lift, a main switch capable of breaking the supply to the lift on all the live conductors shall be provided. This switch shall be capable of interrupting the highest current involved in normal conditions of use of the lift.

This switch shall not cut the circuits feeding the following:

- a) Car lighting and ventilation
- b) Socket outlet on the car roof;
- c) Lighting of machinery spaces;
- d) Socket outlet in the machinery and pulley spaces and in the pit;
- e) Lighting of the lift well including pit;
- f) Alarm device; and
- g) Automatic rescue device.

The switch shall be located,

- 1) in the machine room, where it exists;
- 2) where no machine room exists, in the control cabinet; and
- 3) at the emergency and test panel, when control panel is mounted in the well.

If the emergency panel is separate from test panel, the switch shall be at emergency panel. If the main switch is not easily accessible from the controller cabinet, then the cabinet shall be provided with an isolating switch.

The main switches shall have stable open and closed positions, and shall be capable of being locked-off in the open position with the use of a padlock or equivalent, to ensure no inadvertent operation takes place.

For a single lift, this switch should be fixed adjacent to the machine room entrance in the machine room. In a machine room common to more than one lift, each main switch should be conveniently situated with respect to the lift it controls.

The supply to the car light should be from a separate circuit, and controlled by a switch in the machine room. For multiple lifts with a common machine room a separate supply should be provided for each car. The car lighting supply should be independent of the power supply mains

Any capacitors to correct the power factor shall be connected before the main switch of the power circuit.

6.2.2 Residual Current Device

Residual current device (RCD), if provided, right type and sensitivity shall be selected.

The RCD shall,

- a) have 10 times the maximum leakage current (300 mA maximum) as tripping current and be suitable for frequency converters with a 3-phase supply.
- b) be sensitive for sinusoidal currents up to 1 000 Hz, insensitive for currents more than 1 000 Hz.

NOTE — This kind of RCDs are generally classified as 'Type B'.

Three-phase power supply for the lift should never be protected with a 30 mA residual current device (RCD). The 30 mA RCD trips easily when the lift starts to drive and prevents the lift to run. If the construction-time power supply is for some reason protected with a 30 mA residual current device (RCD), suitably sized isolation transformer needs to be provided by the electrical contractor.

6.2.3 Supply Cables Wiring and Apparatus

The main power supply cables providing the electricity supply to a lift installation shall be flame retardant type PVC or XLPE insulated armoured cables. The cable should be terminated in the main switch. For each lift, one $415^{+6\text{ Percent}}_{-10\text{ Percent}}$ V, 3-phase, 4-wire, 50 Hz and one single phase $230^{+6\text{ Percent}}_{-10\text{ Percent}}$ V, 2-wire, 50 Hz supply shall be independently provided. Other than this, power circuit at $230^{+6\text{ Percent}}_{-10\text{ Percent}}$ V percent for power and lighting sockets in the lift machine room and the lift shaft shall be provided. This is to facilitate maintenance and other related works with lighting and socket outlets while the lift is switched off.

No cables which are not part of lift installation shall be run in the lift well. The lift cables shall be run in respective lift wells.

Fixed electrical wiring for circuit voltage up to 250 V located in lift wells shall be one of the following:

- a) PVC wires encased in rigid metal conduit or trunking.
- b) PVC insulated PVC sheathed cables.
- c) PVC wires in flexible metallic or plastic conduits not exceeding 1 500 mm in length for limit switches, interlocks, push buttons and similar devices.

Control cables on lift cars shall be run in rigid metallic conduit or trunking. Short runs of flexible conduits may be used, where they are securely fastened in place and not exposed to oil and grease. Short runs of flexible cord may be used as flexible connections between fixed wirings on the car and the switch on car door provided that chord is securely fastened in position and so located as not to be subjected to mechanical damage.

Wiring in machine room shall be run in rigid metallic trunking. The trunking in machine room floor shall be flush with the finished floor to avoid trip hazard. The following additional requirements may also be taken care of:

- 1) The lift sub-circuit from the meter room should be separate from other building services. Each lift should be capable of being isolated from the mains supply. This means of isolation should be lockable. The electric supply cables shall run in a route safe from fire, subsequently within the respective lift shafts to the machine room.
- 2) For banks of interconnected lifts, a separate sub-circuit is required for the common supervisory system, in order that any car may be shut down without isolating the supervisory control of the remainder lifts.
- 3) When the alarm system is connected to a transformer or trickle charger, the supply should be taken from the machine room lighting.
- 4) All electrical supply lines and apparatus in connection with the lift installation shall be so constructed and shall be so installed, protected, worked and maintained that there may be no danger to persons therefrom.
- 5) All metal casings or metallic coverings containing or protecting any electric supply lines of apparatus shall be efficiently earthed.
- 6) No bare conductor shall be used in any lift car as it may cause danger to persons.
- 7) All cables and other wiring in connection with the lift installation shall be of suitable grade for the voltage at which these are intended to be worked and if metallic covering is used it shall be efficiently earthed.
- 8) Suitable caution notice shall be affixed near every motor or other apparatus in which voltage used exceeds 250 V.
- 9) A single trailing cable for lighting control and signal circuit shall be permitted, if all the conductors of this trailing cable are insulated for maximum voltage running through any one conductor of this cable.

- 10) *Emergency signal or telephone* — The lift car shall be provided either with an emergency signal that is operative from the lift car and audible outside the lift well or with a telephone.
- 11) When an alarm bell is to be provided, each car is fitted with an alarm push button which is wired to a terminal box in the lift well at the ground floor by the lift manufacturer. This alarm bell, to be supplied by the lift manufacturer (with indicator for more than one lift) should be fixed in an agreed position and wired to the lift well. The supply may be from a battery (or transformer) fixed in the machine room or, when available, from the building fire alarm supply.
- 12) When a telephone is to be provided in the lift car the lift manufacturer should fit the cabinet in the car and provide wiring from the car to a terminal box adjacent to the lift well. Alternatively, a hands-free unit may be provided. The type of telephone should be stated in the enquiry.

6.2.4 Earthing

There shall be separate exclusive earth pit for the lift or a group of lifts or the same shall be connected to equipotential bonding system. There shall be two separate and distinct earth conductors provided from the earth pit to the machine room as per good practice [8-5A(8)]. The cross-sectional area of copper earthing conductor shall be not smaller than half that of the largest current-carrying conductor subject to an upper limit of 65 mm².

In case of buildings having earthing through earth mats or earth grids, it is permissible to earth the lift equipment with separate conductors from these earth mats/grids. Separate earth pits shall not be a requirement in this case.

The terminal for the earthing of the frame of the motor, the winding machine, the frame of the control panel, and similar electric appliances which normally carry the main current shall be at least equivalent to a 10 mm diameter bolt, stud or screw.

The terminal for the earthing of the metallic cases and covers of door interlocks, door contacts, call and control buttons, stop buttons, car switches, limit switches, junction boxes and similar electrical fittings which normally carry only the control current shall be at least equivalent to 5 mm brass screw (such terminal being one specially provided for this purpose), and the earth conductor size shall be at least equivalent to 0.5 mm² copper.

The earth conductor shall be secured to earthing terminal in accordance with the recommendations made in good practice [8-5A(8)] and also in conformity with the latest provisions of *The Indian Electricity Act, 2003* and the Rules framed thereunder from time to time.

The exposed metal parts of electrical apparatus installed on a lift car shall be sufficiently bonded and earthed.

Where screwed conduit screws into electric fittings carrying control current making the case and cover electrically continuous with the conduit, the earthing of the conduit may be considered to earth the fitting. Where flexible conduit is used for leading into a fitting, the fitting and such length of flexible conduit shall be effectively earthed.

7 FIRE PROTECTION REQUIREMENTS FOR LIFTS

7.1 Fire Protection Requirements of Lifts in High Rise Buildings

7.1.1 Buildings of Height 15 m and Above

Following requirements over and above those specified in 6 and 8 and in Part 4 'Fire and Life safety' of the Code are applicable to all lifts provided in buildings having height more than 15 m:

- a) All materials of constructions in load bearing elements, stairways and corridors and facades shall be non-combustible.
- b) The interior finishing materials shall be of very low flame spread type.
- c) Walls of the lift bank well enclosure for a lift or group of lifts shall have a fire rating of 120 min. The lift well shall have a vent at the top, of area not less than 0.2 m² per lift.
- d) *Landing doors* — Lift landing doors shall be imperforate. Collapsible doors shall not be permitted. Lift landing doors provided in the lift enclosure shall have a minimum fire resistance rating of 60 min.
- e) *Lift car door* — Lift car doors shall be imperforate. Collapsible car doors shall not be permitted.
- f) Telephone or other communication facilities shall be provided in the lift car and the lift main lobby. Communication system for lifts shall also be connected to the fire control room of the building if provided. For lifts for use by persons with disabilities, the facilities shall be provided in accordance with 13 of Part 3 'Development Control Rules and General Building Requirements' of the Code.

- g) Photo luminescent safety signs shall be posted and maintained on every floor at or near the lift indicating that in case of fire, occupants shall use the stairs unless instructed otherwise. The sign shall have the plan of the respective floor showing location of the stairways. The plan shall also indicate the direction to and the level of refuge area. All signs posted and maintained on every floor of buildings open to and used by the public shall comply with the requirements of accessible signage given in 13 of Part 3 'Development Control Rules and General Building Requirements' of the Code.
- h) All lifts (fireman's lifts/non fireman's lifts) shall be provided with Phase I operation as per 7.1.1(k)(x) (grounding operation).
- j) The grounding operation may be initiated by individual switches for lifts or a common switch for a group of lifts or by a signal from fire alarm system of the building if available.
- k) *Fireman's lift* — The fireman's lift is provided in a building for the purpose of aiding firefighters in evacuating trapped persons in the building and to take the equipment for fighting fire to upper levels with minimum delay. Some lifts out of all the lifts shall be identified as fireman's lifts.

The number of required fireman's lifts and their locations in a building will vary depending on the size, design, complexity of the building. Some considerations are as follows:

- 1) There shall be at least one fireman's lift per building.
- 2) If there are multiple wings in the building, there shall be at least one fireman's lift per wing.
- 3) If there are multiple banks of lifts in the building there shall be at least one fireman's lift per bank of lifts.
- 4) If the building height is up to 600 m and it is zoned height-wise and it does not have single fireman's lift serving every floor of the building, then there shall be at least one fireman's lift per zone which shall serve the main level/fire access level and shall serve all the landings in the respective zone.
- 5) If the building height is more than 600 m and it does not have any single fireman's lift serving all the floors, that is, it has all lifts serving only respective zones,

the fireman's lift shall be provided in each zone separately, serving all landings in respective zone, with a transfer landing for transferring from one zone to another.

Considering all the above, the fireman's lift(s) shall be identified on the building plan and duly displayed in Fire Command Centre.

To be effective in firefighting operation, the fireman's lift shall have following requirements:

- i) The fireman's lift may be used by the occupants in normal times.
- ii) The fireman's lift shall be provided with a fireman's switch. The switch shall be a two position (ON/OFF) switch fixed at the evacuation floor (normally main entrance floor) for enabling the lift to be put into fireman's mode. The switch shall be situated in a glass-fronted box with suitable label and fixed adjacent to the lift at the entrance level. When the switch is on, landing call-points shall become inoperative and the lift shall be on the car control only or on a priority control device. When the switch is off, the lift will return to normal working.
- iii) The fireman's lift shall be provided with an audio and visual signal in the car.
- iv) The fireman's lift shall have a floor area of minimum 1.43 m². It shall have loading capacity of not less than 544 kg (8 persons lift).
- v) The fireman's lift shall be provided with power operated (automatic) doors of minimum 0.8 m width.
- vi) The speed of the fireman's lift shall be 1.0 m/s or more such that it can reach the top floor from main floor/firefighter access level within 1 min. In case the building is zoned, the fireman's lift shall operate from the lowest served landing to the topmost served landing in 1 min.
NOTE — Notwithstanding the above, the speed of lifts shall be established based on 4.
- vii) Reliable alternative source of power supply should be provided for all fireman lifts through a manually/automatically operated change-over switch. The route of wiring shall be safe from fire.
- viii) Suitable arrangements such as providing slope in the floor of lift lobby shall be made at all the landings to prevent water used during firefighting from entering the lift shafts.

ix) The words 'Fireman Lift' shall be conspicuously displayed in fluorescent paint on the lift landing.

x) *Operational requirements of fireman's lift* — The lift shall be provided with the following operational controls, phase I and phase II.

- a) *Phase I — Return to evacuation floor* — Shall start when the fireman's switch at the evacuation floor is turned to the 'ON' position or the signal from smoke detector (if provided by the Building Management System) is on. All lifts controlled by this switch shall cancel all existing car calls and separate from landing calls and no landing or car calls shall be registered. The audio and visual signal shall be turned on. All heat and smoke sensitive door reopening devices shall be rendered inoperative.

If the lift is travelling towards the evacuation floor, it shall continue driving to that floor.

If the lift is travelling away from the evacuation floor, it shall reverse its direction at the nearest possible floor without opening its doors and return non-stop to the evacuation floor.

If the lift is standing at a floor other than the evacuation floor, it shall close the doors and start travelling non-stop to the evacuation floor.

When at the evacuation floor, the lift shall park with doors open.

The continuous audio signal is turned off after this return drive.

NOTE — If the building is designed for alternative evacuation floor, in case of fire at main floor the lifts shall park at the alternative evacuation floor with doors open.

- b) *Phase II — Operation of the lift shall be as defined below* — The phase 2 is started after phase 1, if the fireman's switch is 'ON'.

If the lifts are grounded by the smoke detector signal, for phase II to begin it shall be necessary to turn the fireman's switch 'ON'.

The lift does not respond to landing calls but registers car calls. All heat and smoke sensitive door reopening devices are rendered inoperative.

When the car call button is pressed, the doors start closing. If the button is released before the doors are fully closed, they re-open. The car call is registered only when the doors are fully closed.

After registering a car call the lift starts driving to the call. If more than one car call is registered, only the nearest call is answered and the remaining calls will be cancelled at the first stop.

At the floor the doors are opened by pushing the door open button. If the button is released before the doors are fully open, they re-close.

The lift returns to normal service when it stands at the evacuation floor with doors open and the switch is turned 'OFF' thereafter.

The operation of fireman's lift shall be by means of a full set of push buttons in the car. Other operating systems shall be rendered inoperative.

7.1.2 Buildings of Height 60 m and above

The following requirements over and above those specified in 7.1.1 are applicable to the lifts and lift enclosures provided in buildings having height more than 60 m.

- a) *Fireman's lifts* — Following additional requirements apply to all fireman's lifts in the building.
 - 1) The fireman's lift shall have loading capacity of not less than 1 000 kg and floor area not less than 2.35 m².
 - 2) Electrical equipment within the fireman's lift well and on the car, located within 1.0 m of any wall containing a landing door, shall be protected from dripping and splashing water or provided with enclosures classified to at least IPX3 according to good practice [8-5A(9)].
 - 3) The electrical switchgear placed less than 1 m above lift pit floor shall be protected to IP 67 as per to good practice [8-5A(9)]. The socket outlet and lowest lamp shall also be located at least 0.5 m above the highest permissible water level in the pit.
 - 4) Suitable means shall be provided in the lift pit to ensure that water will not rise above the level of the fully compressed car buffer.
 - 5) Means shall be provided to prevent the water level in the pit from reaching equipment which could create a malfunction of the fireman's lift.

- 6) Alternative source of power supply shall be provided for all fireman's lifts through automatically operated changeover switch. In case of failure of normal electric supply, it shall automatically trip over to alternative supply. The route of wiring shall be safe from fire.

- b) There shall be Fire Command Centre (FCC) and/or Building Management System (BMS) room in the building. CCTV cameras shall be fixed in the lift lobbies and the display screen(s) shall be placed in the FCC or BMS room.

7.2 Evacuation Lifts

Buildings, particularly super high rise (height more than 200 m) buildings, may be designed for a systematic evacuation of persons in case of emergencies that are relevant to a specific building. There are many reasons why a building may need to be evacuated, for example, a fire, explosion, chemical or biological attack, flooding, storm damage, earthquake, etc. Not all of these are relevant to every building hence those which are not relevant can be disregarded. Designers of buildings shall determine, if a particular hazard is sufficiently great as to require addressing. This clause deals primarily with fire situation although similar logic can be used in case of other situations as well.

The lifts may be planned only supplementary to, not as a replacement of, exits. In fact, using lifts instead of stairs may well increase evacuation times in many building designs, especially low and medium rise buildings. However, lifts may be allowed to play a positive role in assisting and improving efficiency of the building evacuation strategy especially for persons with disabilities. The building designers should decide, if they want to use lifts for evacuation purpose. It may be noted that in general a fireman's lift may be suitable as an evacuation lift.

7.2.1 Pre-requisites to Using Lifts for Evacuation in Case of Fire

7.2.1.1 Detecting fire, smoke, and temperature

Methods of fire detection are well established. If the lifts are to operate a safe evacuation service, good monitoring of the fire in relation to lift equipment is essential.

To ensure the safety of users and lift equipment; the lift machine room, lift well (including lift pit and overhead areas) and landing areas shall be provided with means to detect and monitor for the presence of smoke and heat. Temperature in any safe area provided for persons to wait (lobby, refuge, etc) and the lift well, machine room, etc, should be continuously monitored to

determine if it is safe and remains safe for persons and equipment. When an unsafe temperature or presence of smoke is detected the information should be sent to the BMS or FCC. The BMS or FCC should determine what is to be done next and send appropriate signals to the lift, for example remove lift from service at floor x with doors parked open or closed as required. The equipment used for this sensing and monitoring of heat and smoke should be specified by those responsible for the design of the building fire and smoke detection system.

7.2.1.2 *Location of an event in relation to lifts*

In detecting an event like fire it will be important to know its location in relation to any lift intended for evacuation use. The more the level of sophistication of detection system employed, the more precise will be the level of information available to make decisions and more meaningful these decisions will be. The designer shall determine the degree of sophistication required taking into account the importance of the building, type of occupancy, etc.

7.2.1.3 *Emergency power provisions*

Secondary (emergency) power shall be provided that has sufficient capacity to run all the evacuation lifts at full speed for the required evacuation time. The route of the cabling shall be safe from fire.

7.2.2 *Operational Decisions for Evacuation*

7.2.2.1 *Types of evacuation*

The evacuation strategy developed should lead to an obvious evacuation type. Lifts will not be able to evacuate all floors at once, so to some degree a systematic evacuation will be governed by the capacity of lifts and the number of persons to be evacuated. Lift engineers can calculate the number of persons that can be moved for a given set of circumstances but the first thing to determine is the number of persons to be evacuated within the required evacuation time. Fire engineers/experts shall determine these figures. It shall also be determined what proportion of wheel chair and others with impaired mobility may be there and if there is likely to be a floor or building area with a particular concentration of them.

In many instances some sort of phased evacuation will be desirable while at other times a full evacuation may be essential. Phased evacuation involves the evacuation of certain areas first, usually those floors areas at greatest risk followed by other key areas. Also, there could be horizontal evacuation, partly or fully, for example, in case of hospitals.

7.2.2.2 *Decide, if evacuation is required (building management)*

This is a decision to be made by other experts and those responsible for building management. In large

buildings, evacuation may take some time and it shall not be assumed that continued use of a particular lift or lifts is guaranteed. Serious thought shall be given to how information will be displayed to those managing the building especially where the BMS system is capable of providing a large amount of information. It should be possible to see at a glance if lifts are operating correctly and what services they are running. There shall always be provision made to allow the building management or authorities to override any automatic evacuation signal that is generated by a BMS. Irrespective of the systems employed the evacuation decision cannot be made by a lift system and therefore other experts in this field shall determine what risks will constitute the need for evacuation and the type of evacuation (partial or full).

7.2.2.3 *Decide, if lifts are to be used for the evacuation*

If for some reason a significant number of lifts are not available for use then it may be prudent to remove all lifts from automatic evacuation service rather than have too few. If too few lifts are in service, delays will result that could be dangerous or cause panic. In such circumstances it is probably desirable to run a limited service for the evacuation of those who have difficulty in negotiating stairs. Any such service needs to be managed by lift attendants who will drive the lift, manage possible crowding and assist those who need it. The decision to operate some form of service when not all lifts are available shall be taken by those managing the building evacuation.

7.2.2.4 *Building evacuation information*

When evacuation is required, updated information shall be provided through the building systems informing persons concerned including those in waiting areas which lifts to use during the particular emergency. This information shall be in both audible and visual format. Any safe areas/waiting areas should also have an emergency communication system.

7.2.3 *Specifications of Automatic Evacuation Lift*

7.2.3.1 *Determining the number and size of lifts*

To calculate the number and size of lifts required for an adequate evacuation service, the handling capacity of a given lift or group of lifts shall be determined considering possibility that a lift or lifts may not be available for some reason such as planned maintenance, repairs. Also due consideration shall be given to the requirement of accommodating a wheel chair in the lift car.

7.2.3.2 *Protection of lift equipment*

Lift shafts and machine rooms or machinery spaces located outside the shaft should be fully enclosed. The temperature in the enclosures should be monitored and maintained to acceptable levels for the equipment, as

determined by the lift supplier in consultation with the building management. Protection from water may be considered, if required as per overall evacuation strategy.

7.2.3.3 Removal or suspension of lifts from evacuation service

Where a lift receives a command from a BMS or manual signal to stop or suspend service to a floor or area of the building, any stop shall be a controlled stop at a safe area. A controlled stop means allowing the lift to slow down and stop at a floor in the normal manner. Where a lift or lifts are instructed to suspend service, the lift(s) shall communicate with the FCC and any BMS once it is no longer available for service.

7.2.3.4 Remote lift car surveillance

At times of emergency it is vital to be able to see that lifts do not contain trapped passengers who may be incapacitated. A means to display the entire floor area of the car shall be provided with information to the occupants that the lift car is under surveillance. At least one viewing terminal shall be located in the FCC and clearly marked 'LIFT CAR SURVEILLANCE' with the lift designation identified.

7.2.3.5 Communication system requirements

As a minimum, a 3-way communication system shall be available for passenger use to permit direct communications between the lift car and safe area and FCC. Operation of the communication device in the lift car shall be simply by means of a single button, operation of which shall connect the system to the FCC. Further operation of the device in the lift car shall be hands free.

7.2.3.6 Initiation of evacuation service

Evacuation service can be initiated by a device such as a button or lever, key, etc, located near the lift shaft at the evacuation landing, or from a signal sent by a BMS or hazard detection system. Where a button or other manual activated device is used it shall be protected against unauthorized use. Its purpose shall be clearly marked with a symbol and/or the words 'LIFT EVACUATION SERVICE'.

The evacuation service shall be operational between the floors as decided by the building designer. The logic of operation shall be mutually agreed to between the building designer and the lift designer. However, any lift will be automatically removed from evacuation service if, where provided, it is turned to fire-fighters service.

7.2.3.7 Cancellation of evacuation service

On cancellation of a signal from the device that initiated

the service and receipt of a signal from an evacuation service cancellation switch, all lifts which are not at the main landing shall complete any allocated task and return to the main landing.

On arrival at the main landing the doors shall open and then the lift evacuation for that particular lift shall be cancelled. Any lift already at the main landing shall on opening its doors cancel its evacuation service.

7.2.4 Information to be Provided to the Building Owner

Detailed instructions shall be provided to the building operator by the building designer in the form of a manual. The manual shall explain the evacuation strategies to be used, how any detection systems operate, how they shall be maintained and how the lift will operate on evacuation service. It should also provide advice on periodic checks the owner can make to ensure the system is working correctly and explain the importance of a suitable testing and maintenance system being in place. Training being very important aspect of this new concept, the manual shall include such details of training as who should be covered by training, how the training should be carried out, what should be the frequency, etc.

8 MINIMUM TECHNICAL AND SAFETY REQUIREMENTS

8.1 General Requirements

The following general requirements shall be adhered to:

- a) Passenger and goods lifts shall comply with the safety requirements and/or protective measures of the following clauses. In addition the passenger and goods lifts shall be designed according to good practices [8-5A(2)].
- b) All labels, notices, markings and operating instructions shall be permanently affixed, indelible, legible and readily understandable (if necessary aided by signs or symbols). *See also 13* of Part 3 'Development Control Rules and General Building Requirements' of the Code. They shall be of durable material, placed in a visible position, and written in the accepted language(s).
- c) The minimum factor of safety for any part of the lift shall not be less than five. Higher factor of safety for various parts shall be applicable in accordance with accepted standards [8-5A(5)] and [8-5A(6)].
- d) All passenger, goods, stretcher, automobile, dumbwaiter lifts shall have conformity with *Lifts Acts and Rules* in force, *Indian Electricity*

Act, 2003 and Rules, all relevant and applicable Indian Standards, applicable fire regulations, fire prevention act and rules in force.

- e) *Notices* — The following notices shall be placed at respective places:
 - 1) A notice (*see* Fig. 4) bearing the following (typical) minimum inscription shall be fixed to the outside of doors or trap-doors (excluding landing doors and doors of emergency and test panels) giving access to machine and pulley rooms.
 - 2) In the case of trap-doors, a permanently visible notice (*see* Fig. 5) shall indicate necessary warning to those using the trap-door.
 - 3) Outside of the well, near the access doors and emergency doors, if any, there shall be a notice stating as shown in Fig. 6.
 - 4) A notice board with following instructions as applicable, and/or other applicable instructions shall be placed in conspicuous position in the lift car:
 - i) Maximum capacity of lift ___ kg/ ___ persons.
 - ii) Close the car and landing door/gate properly, on entering, or while leaving the lift car.
 - iii) Do not open the lift-car gate when the lift-car is moving. The gate should only be opened after the lift-car has stopped opposite a landing gate.
 - iv) In case of danger, press the alarm button, but do not try to open the car door. Wait inside, until the lift car is brought opposite a landing, and do not attempt to leave the lift car until the landing door is opened fully.
 - v) Children under 12 years of age shall not use the lift, unless accompanied by an adult.
 - 5) The following is a typical list of Do's and Don'ts that should be displayed in the lift car, and in case of lifts open to public use, in an accessible format complying requirements of accessible information board/signage, given in 13 of Part 3 'Development Control Rules and General Building Requirements' of the Code:

<i>Do's</i>	<i>Don'ts</i>
a) Press call button lightly	a) Do not overload the lift
b) Know your destination. Push lift call for direction you want to go	b) Do not press call button again and again
c) Stand aside for exiting passenger	c) Do not force-open the doors, it is dangerous
d) Pay attention to floor indicator	d) Do not stand in between the doors
e) Push and hold the door open button, if door needs to be held open	e) Do not fiddle with the equipment
f) Wait for the next car, if the lift is full	f) Do not step in until lift has stopped at landing and doors are fully open
g) Take the stairs, if there is a fire	g) Do not crowd in the middle of car
h) In, contact case of emergency, contact customer service cell for rescue operation	h) Do not lean against car panels
	j) Do not panic in case of power failure
	k) Do not attempt to jump out, if the lift has stopped out of floor level

NOTE — No distracting notice/advertisement should be fixed in the lift car.

8.2 Power and Control Systems

8.2.1 Features Associated with Power Systems

The features associated with power systems are listed below.

8.2.1.1 Industrial switchgear

Switchgear for controlling lift power systems is characterized by its high duty cycle and its high rupturing capacity. Switchgear shall be robust enough and shall be so designed as to withstand the high duty cycle and high rupturing capacity introduced during the operation of the lifts.

8.2.1.2 Levelling accuracy

The levelling tolerances in accordance with good practice [8-5A(7)] are those which can be reasonably expected between no load and full load in either direction. With the VVVF drives good leveling accuracy can be expected.

8.2.1.3 Corrective levelling

This should only be used, when it is impossible otherwise to achieve the required levelling tolerances or on long travel lifts to maintain the required levelling tolerances during loading and unloading.



FIG. 4 TYPICAL INSCRIPTION ON DOORS



FIG. 5 TYPICAL NOTICE ON TRAP DOORS



FIG. 6 TYPICAL NOTICE ON ACCESS DOORS AND EMERGENCY DOORS

8.2.1.4 Levelling with variable voltage

A variable voltage system is one using continuous regulation which minimizes speed differences due to load variation. Therefore, the actual levelling speed is of less importance than the general refinement of its regulation control. In fact no levelling speed as such may be identifiable.

8.2.1.5 Overload tests

A lift is designed to operate and transport the contract load, at the required duty cycle, and should not by intention or habitually be used to carry overloads. During test as a safeguard to cover variable supply and temperature conditions a lift is checked for the car to complete one round trip with contract load plus 10 percent at nominal supply voltage and nominal ambient temperature. There is also a static test with contract load plus 25 percent to check that the brake will sustain the car. It is unnecessary to specify an additional overload test or capacity and in fact it is detrimental to the normal running efficiency and safety of the lift to do so.

8.2.1.6 Occasional extra load

It is not good practice to request that a lift should be designed to carry an occasional extra load. It is tantamount to specifying an excessive overload test which is detrimental to the normal running efficiency and safety of the lift.

8.2.2 Description of Operation Systems

The following description relates to the associated operating systems.

8.2.2.1 Methods of control systems

The methods of control systems are as follows [see 8.2.2.2 (a)]:

- a) Attendant and dual control, and
- b) Automatic push button operation.

8.2.2.2 Types of control systems

The features of control systems shall be as described below:

- a) *Automatic push button operation* — Automatic control is a method of operation by which a momentary pressure on a push button sets the car in motion and causes it to stop automatically at any required lift landing. This is the simplest control system and it is sometimes referred to as push button control. A car answers a landing or car call, whichever is actuated first by momentary pressure provided the lift is not in use. Momentary pressure of a car push button will send the car

to the designated floor. The car always responds to a car push button in preference to a landing push button. With this type of control, a red landing signal light or direction arrow indicates that the car is in use that is the lift is travelling. This type of control is recommended for single passenger lifts serving up to 4 floors and goods lifts.

For special purposes, the following two systems may be considered:

- 1) Dispatch from landings as an additional feature for a goods lift with manually operated doors. The call is registered by pressing the car push button and when the doors are closed the car will travel to the designated floor.
 - 2) Automatic with attendant control as an additional feature on goods lifts with a key operated switch in the car to transfer the control from normal automatic to attendant operation. There is also a visual call indicator with buzzer in the car to indicate to the attendant the landing floors at which push buttons have been pressed when the car is under attendant control.
- b) *Collective control* — Collective control is a generic term for those methods of automatic operation by which calls made by pressing push buttons in the car and at lift landings are registered and answered by the car stopping in floor sequence at each lift landing for which calls have been registered irrespective of the order in which the calls have been made, and until all calls have had attention. Collective control of any form is usually not suitable for goods lifts except where loading is not expected to fill the car and additional loads can be taken at other stops.
 - c) *Single push button collective control* — Single push button collective control has a single push button at each landing. It is not recommended, as the direction in which it is desired to travel cannot be registered by the intending passenger.
 - d) *Down collective control* — Down collective is a control system where landing calls are registered from a single push button, irrespective of the car being in motion or the landing door being open and calls are stored until answered. Any number of car calls can be registered and the car will stop in sequence in the down direction at each of the designated floors. The car will travel in the up direction to the highest call registered stopping only in

response to car calls. It will then travel downwards answering calls in floor sequence. If only one call has been registered the car travels to the floor of call.

This system is suitable where there is traffic between the ground and upper floors only and no inter floor traffic. Two or three car banks have interconnected control. With this type of control the following signals are included:

- 1) A landing signal light indicates that the call has been registered and will be answered.
 - 2) Illuminated car position indicator above car entrance.
- e) *Directional collective control for one car* — Directional collective control for one car is a control system having ‘UP’ and ‘DOWN’ push buttons at intermediate landings whereby the call is registered for the intended direction of travel. Calls from the car or landing push buttons are registered and stored until answered. The car will answer calls in floor sequence in one direction of travel. Calls for the opposite direction of travel are answered when the direction of travel is reversed.

This system is suitable for single lifts serving 4 or more floors with inter floor traffic, such as small office blocks, hotels and blocks of flats. With this type of control the following signals are included:

- 1) A landing signal light for each landing push button indicates that the call has been registered and will be answered.
 - 2) Illuminated car position indicator above the entrance in the car.
 - 3) Arrow shaped signal lights in the back of the car or on the landing to indicate to the entering person in which direction the car is going to depart.
- f) *Directional collective control for two or three cars* — Directional collective control for two or three cars is a system covering a control in which the two or three cars in a bank are interconnected. One push button unit with ‘UP’ and ‘DOWN’ push buttons or floor buttons (in case of car control from floor) are required at each landing and the call system is common to all lifts. If for architectural balance, in the case of a three car bank, extra push button units are required, these should be specified. Each landing call is automatically allocated to the best placed car.

The control is designed so that cars are effectively spaced and thus give even service. When a car reaches the highest floor to which there is a call its direction of travel is automatically reversed when it next starts. One or more cars will return to the parking floor. Automatically bypassing of landing calls when a car is fully loaded is an essential feature for three-car banks. It is also necessary for two-car banks in offices. Other cars will continue to provide service to all floors. When three-car banks serve 7 or 8 floors and over, some form of automatic supervisory control [see 8.2.2.2(g)] is generally necessary in the interest of efficiency. With this type of control the following signals are included:

- 1) A landing signal light for each landing push button to indicate that the call has been registered and will be answered.
 - 2) Illuminated car position indicator above the entrance in the car.
 - 3) Arrow shaped signal lights in conjunction with an audible single stroke gong or an indication on the landing call push button station above each landing entrance to indicate to the waiting person(s) which car is going to stop and in which direction it will continue its course.
- g) *Group supervisory control* — A bank or group of intensive traffic passengers lifts requires a supervisory system to coordinate the operation of individual lifts which are all on collective control and are interconnected. The very nature of intensive service calls for a sophisticated automatic supervisory control system so as to match the speed capacity of these lifts. The supervisory system regulates the despatching of individual cars and provides service to all floors as different traffic conditions arise minimizing such unproductive factors as idle cars, uneven service and excessive waiting time. The system will respond automatically to traffic conditions such as ‘UP’ and ‘DOWN’ peaks, balanced or light traffic and provides for other specialized features. If desired, a master station can be provided in the lift lobby which gives by indicators, visual information regarding the pattern under which the system is operating. Where the system is based on a definite programme, control means are provided for altering the type of traffic programme. There are other facilities, such as the removal of any lift from service.

- h) *Destination control system* — In case of a bank of lifts Destination Control System (DCS) may be provided. The passengers enter their destination floors on the Destination Operating Panels (DOPs) provided on the lift landings. The lift controller allocates a lift to every call registered which is displayed on the DOP. The passenger is expected to board the assigned lift and travel to his destination floor. He need not register his destination floor in the lift car operating panel (COP) again. In fact COP in the lift car may not be provided with floor buttons in case of DCS control system. The principle behind the DCS is to group passenger with same destinations together thus reducing the number of stops of the lift reducing round trip time thus boosting traffic.

The advantages of DCS system over conventional collective control are:

- 1) Enhanced passenger handling capacity,
- 2) Less transit time, few intermediate stops, and
- 3) Passengers do not have to struggle through crowd to book the calls.

In addition to the DOPs the lift landings are provided with lift identifier. The main landing may be provided with destination indicator displaying the floor designations the lift would stop at.

Hybrid Destination Control (HDCS) combines features of the DCS and conventional control system. The main floor is provided with DOPs, Lift Identifiers and the lift car is provided with the conventional COP as well. Thus while availing benefit of traffic boosting HDCS provides convenience of call booking from inside the lift car as well.

8.2.2.3 Features of operation systems

The features associated with the operating systems are as follows:

- a) *Car preference* — Sometimes it is necessary to give a special personal service or a house service. When this service is required and for whatever purpose, it should be specified as ‘car preference’ is by a key operated switch in the car. The operation is then from the car only and the doors remain open until a car call is registered for a floor destination. All landing calls are bypassed and car position indicators on the landing for this lift are not illuminated. The removal of the

key when the special operation is completed, restores the control to normal service.

- b) *Landing call automatic bypass* — For collective operation, automatic bypassing of landing calls can be provided. This device will bypass landing calls when a car is fully loaded but the calls are not cancelled.
- c) *Motor generator shut down* — Lifts controlled by variable voltage system automatically shut down when subject to an over-riding control which puts them out of service under certain conditions; for example, no demand for lift service. They are automatically put back into service as required.
- d) *Basement service* — For lifts with collective control when service is required below the main parking floor, which is usually the ground floor, to a basement and/or a sub-basement, the lift manufacturer should be informed of the type of service required, as special technical considerations are then usually necessary.
- e) *Hospital service* — Lifts for carrying beds and stretchers require a car preference switch so that an attendant can have complete control of the car when required. This requirement should be specified as ‘car preference’ and it will function as described in 8.2.2.1. Otherwise such lifts can have the same control systems as for normal passenger lifts, the choice depending on the number of floors served, the service required and the number of lifts.
- f) *Manually operated doors (without closers)* — A ‘door open’ alarm should be provided to draw attention to a car or landing door which has been left open.
- g) *Automatically power closed doors* — For passenger operation when the car arrives at a landing the doors will automatically open and then close after lapse of a time interval. This time interval can be overruled by the pressure of a push button in the car to give instant door closing. An ‘open door’ push button is provided in the car to reverse closing motion of the doors or hold them open.
- h) *Controlled power closed doors* — When there are conditions that particularly affect the safety of passengers or damage to vehicles or trucks, the closing of the doors should only be made by the continuous pressure of push buttons in the car or on landings. A ‘door open’ alarm should be provided to draw attention to a car

or landing door which has been left open. This means of operation is required for some forms of goods lifts.

- j) *Safe operation of doors* — The safety of passengers passing through lift entrances is fully covered by the provision of good practice [8-5A(6)]. No modification of these provisions should be specified.
- k) *Directorial service* — There are many forms of giving special service for individuals, but they should always be avoided. They range from key operated switches at preferred landings to the complete segregation of one out of a bank of lifts. It is obvious that any preferential treatment of this nature can seriously jeopardize the efficiency of the service as a whole. When a bank of say three lifts is installed to meet the anticipated traffic requirements and then, when the building is occupied, one lift is detached permanently for directors' service, the traffic handling can be reduced by a half rather than a third. When preferential service is imperative, then the car preference feature should be available [see 8.2.2.3(a)].
- m) *Indication of car arrival* — As all lift cars are illuminated when available (in service). It is recommended that this illumination be used to signal the arrival of a car at a landing in preference to special signals such as 'LIFT HERE' signs since signal lamps can fail when the lift is still operating satisfactorily.
- The following is the practice adopted for vision panels in doors:
- 1) For lifts with manually operated car and landing doors, vision panels are provided in all doors;
 - 2) For lifts with power operated car doors and manually operated landing doors, vision panels are provided in the landing doors only;
 - 3) For lifts with automatically opened car and landing doors, no vision panels are required; and
 - 4) When vision panels are provided they should comply with the requirements of good practice [8-5A(7)].
- n) *Service switches* — When switches are provided to take cars out of service, that is because the remaining cars in the group can cater for the required passenger traffic, it is

essential that such switches should not stop the fireman's control from being operative in the event of the lift being designated as a fireman's lift. Service switches should not be confused with maintenance switches which are only used when it is dangerous to attempt to operate the lift because maintenance work is actually in progress. A control station fitted on top of the car is regarded as a maintenance switch.

- p) *Fire switch* — When required by the fire authority a fire switch has to be provided, the function of which is to enable the fire authority to take over the complete control of one or more lifts in an installation.
- q) *Push buttons and signals* — It is most important that the purpose of every push button and signal should be clearly understood by all passengers.
- r) In public places where blind persons are expected to use the lifts it is recommended to provide Braille/tactile buttons.

8.3 Capacity and Loading

The minimum rated load of a passenger lift car corresponding to the net inside car area shall bear the relationship given in Fig. 7, the net inside car area being evaluated as shown in Fig. 8. The net inside car areas for various passenger capacities with corresponding minimum rated loads have been given in Table 24.

NOTES

1 The graph shown in Fig. 7 is based on the following formula:

$$W = 35.05 A^2 + 325.66 A$$

where

W = rated load, in kg; and

A = net inside area, in m².

2 For rated loads exceeding those covered by the graph, value may be evaluated from the formula given above.

3 To avoid the possibility of serious overloading of bed lifts, they shall be treated as passenger lifts.

4 The minimum rated load for goods lifts shall be based on a load of not less than 3.45 kN/m² of the net inside car area.

5 The minimum rated load for automobile lifts shall be based on a load of not less than 1.45 kN/m² of the net inside car area.

6 When the load in a goods lifts consists of pallets or similar single piece loads loaded by means of a power truck, it is necessary during loading and unloading to take into account the total load on the car platform the capacity of the brake, and the resistance to slipping of the ropes on the sheave of a traction machine. Similarly, guide rails, guide fixing, car frame and platform shall be designed to withstand the horizontal thrust imposed by power trucks, motor vehicles and the like.

7 For motor vehicle and other special purpose lifts for transportation of light weight and heavy volume loads, the lift car inside dimensions mutually agreed to between the manufacturer and the purchaser will be permitted with the provision of a device to prevent the lift from starting from a landing in case of overloading.

8 A load plate giving the rated load of the lift shall be filled in each lift car in a conspicuous position. For passenger lifts, the rated load shall be given in number of person and kg. For goods lifts, the rated load shall be given in kg or other convenient units and in persons. For the purpose of this clause, a person shall be regarded as weighing 68 kg.

Table 24 Minimum-Maximum Net Car Areas for Various Rated Loads
(Clause 8.3)

Sl No.	No. of Passengers	Minimum Rated Load kg	Minimum Net Inside Car Area m ²	Maximum Net Inside Car Area m ²
(1)	(2)	(3)	(4)	(5)
i)	4	272	0.68	0.77
ii)	5	340	0.85	0.95
iii)	6	408	1.00	1.12
iv)	7	476	1.16	1.28
v)	8	544	1.31 ¹⁾	1.45
vi)	9	612	1.46	1.60
vii)	10	680	1.61	1.76
viii)	11	748	1.77	1.91
ix)	12	816	1.92	2.05
x)	13	884	2.06	2.20
xi)	14	952	2.23	2.34
xii)	15	1 020	2.35	2.47
xiii)	16	1 088	2.48	2.61
xiv)	17	1 156	2.62	2.74
xv)	18	1 224	2.75	2.87
xvi)	19	1 292	2.88	3.00
xvii)	20	1 360	3.01	3.13
xviii)	21	1 428	3.14	3.25
xix)	22	1 496	3.26	3.38
xx)	23	1 564	3.39	3.50
xxi)	24	1 632	3.51	3.61
xxii)	25	1 700	3.62	3.73
xxiii)	26	1 768	3.74	3.85
xxiv)	27	1 836	3.86	3.96
xxv)	28	1 904	3.97	4.07
xxvi)	29	1 972	4.08	4.18

¹⁾ Minimum net car inside area for fireman lift is 1.43 m².

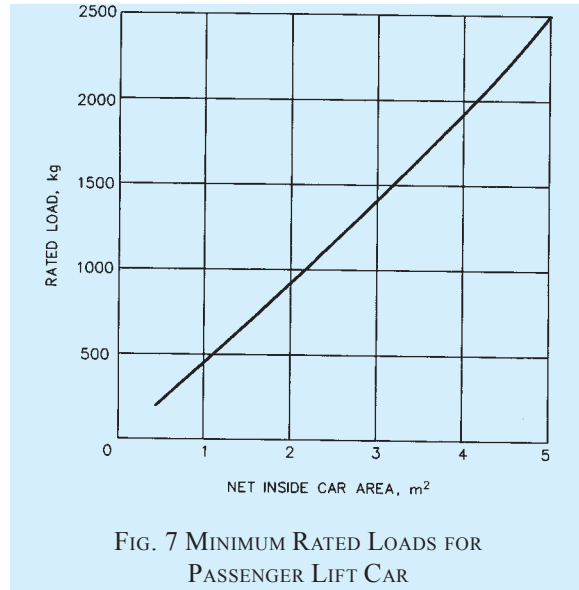

8.4 Other Technical and Safety Requirements

8.4.1 Passenger lifts shall be provided with power operated doors which are imperforate.

8.4.2 Power operated car doors on automatically operated lifts shall be so designed that their closing and opening is not likely to injure a person. The power operated car door shall be provided with a sensitive device which shall automatically initiate reopening of the door in the event of a passenger being struck or is about to be struck by the door, while crossing the entrance during closing movement. The effect of the device may be neutralized,

- a) during the last 58 mm of travel of door panel in case of side opening doors;

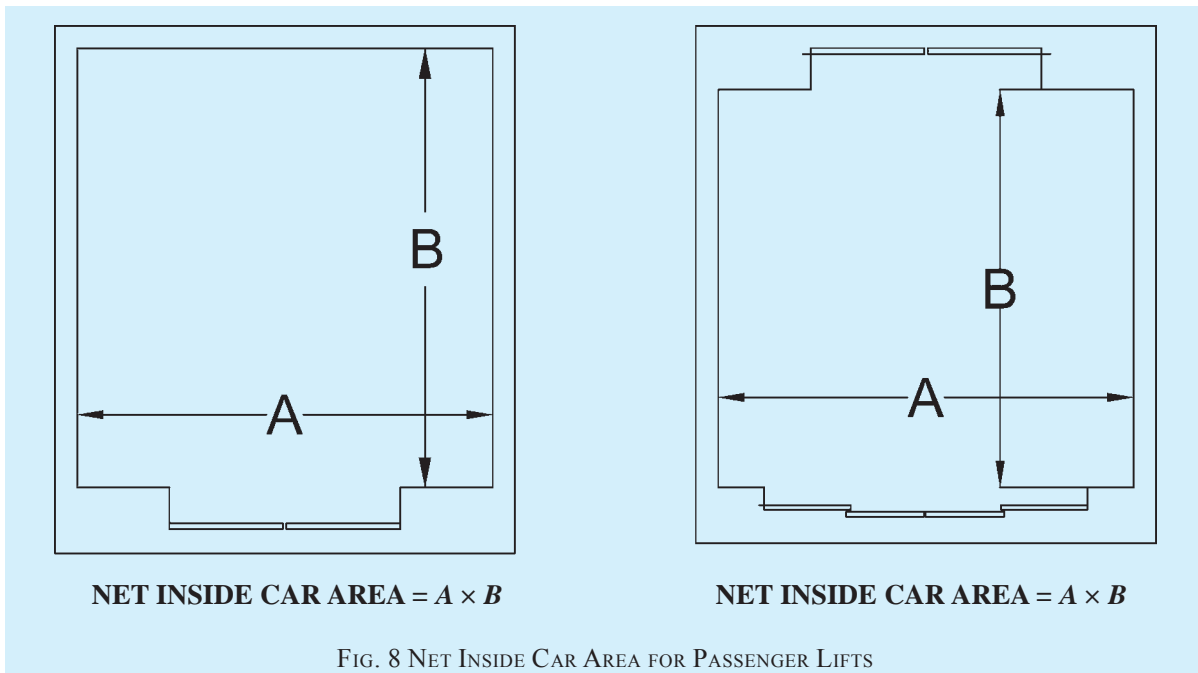

- b) when panels are within 58 mm of each other in case of center opening doors; and
- c) during emergency fire operation.

The force needed to prevent the door from closing shall not exceed 150 N and this measurement shall not be made in the first third of the travel of the door. In order to achieve this it is desirable that all power operated doors have a full length (covering at least 1 600 mm of car door height from bottom) infrared or equivalent light curtain safety to retract the door in the event of coming across any obstacle during closing of the door.

8.4.3 Single speed and two speed drives which are poor in levelling accuracy and energy consumption shall not be used for new lifts in view of availability of latest technology energy efficient variable voltage variable frequency (VVVF) drive systems with improved levelling accuracy.

8.4.4 For passenger lifts with car call button control in car, an additional car operating panel with call buttons shall be provided for ease of access to call buttons when the car is wider than 1 600 mm and/or the rated capacity of the lift is 16 passengers and more. This additional car operating panel shall be suitably located in the lift car.

8.4.5 Battery operated Automatic Rescue Device (ARD) shall be provided on all lifts to take lifts to the nearest possible landing in case of power failure, which includes power failure of one or more phases. In case of lifts equipped with backup generator with AMF (Automatic Mains Failure) panel, the provision of ARD is optional. For all lifts with ARD, an audio and visual indicator shall be provided inside the lift car to alert the persons trapped inside that they are being rescued. Capacity of batteries shall be such that minimum three rescue operations can be performed without recharging. Emergency light and at least one fan inside the lift car shall be operational till the end of rescue operation. Levelling accuracy of ± 40 mm or better shall be achieved in the ARD Operation. The ARD should operate only when all safety circuits are operational. The safety circuits shall be checked and verified continuously during the rescue operation.

8.4.6 Minimum one stretcher lift shall be provided in each building having height more than 30 m so as to take care of medical as well as other emergencies. This lift shall have minimum car entrance width of 800 mm and car depth of 2 100 mm.

8.4.7 Every passenger lift shall be provided with an overload device which will prevent the lift from starting in case the lift car is loaded to 110 percent of the rated capacity of the lift or more. The lift shall remain stationary with door open. Audio and visual warning device shall be provided to alert the passengers in case of overload.

8.5 Painting at Works and on Site

Lift equipment will normally receive a protective coat of paint at works before dispatch to site. Further painting of lift equipment may be necessary and is normally in the form of a finishing coat and can take place on site. Alternatively, the further painting of the equipment may be carried out at works as a finishing coat with normal touching up after site erection as may be necessary. Any additional painting, due to site conditions during erection and/or final operating conditions in the premises, is subject to negotiation between the lift manufacturer and the purchaser. Decorative finishes are a subject for separate negotiation.

8.6 Emergency Manual Rescue

The emergency manual rescue operation with brake release should only be carried out in an emergency and by authorized persons who have received necessary instructions, because it is dangerous for any other persons to attempt to do so.

Before attempting to move the car, it is imperative that any person in the car be warned of the intention to move the car and that they shall not attempt to leave the car until they are advised that it is safe to do so. Any failure to carry out this precaution may render the person concerned guilty of negligence should an accident occur.

Before attempting to hand wind the lift machine, it is vital that the supply is switched off at the main switch. It is usually necessary to have two persons in the machine room: one to operate the brake release and the other to carry out the hand winding. The exceptions are small lift machines where the hand winding can be easily controlled by one man and larger machines which need two men to operate the hand winding alone with an additional man to control the brake release. In case of gearless machines especially, the brake shall be released and applied at very short intervals (of the order of 0.5 s to 1 s) so as to avoid the lift car attaining dangerously high speed due to the lift car and create unbalance in the absence of the gear box with large reduction ratio.

If the car is stuck in the lift well and cannot be moved when an attempt is made to move it in a downward direction, then no attempt at hand winding should be made because the car safety gear may have set. Any further procedure should be carried out under the instruction of a qualified lift mechanic. Provided the car is free to be moved in the downward direction, then it should be hand wound to the nearest floor. There is a preference to move the car in down direction. However, this may not always be practical owing to the distance involved and the time taken to complete the movement. In addition the amount of

out of balance load on the counterweight side, due to the size of car and the small number of persons inside it, may make it necessary to wind the car upwards. In the case of high speed lifts the direction of hand winding will usually be governed by the effort required to move the car because of the absence of a large gear reduction ratio. It is essential that all detail operations be carried out according to the manufacturer's instructions for the lift concerned and these should be clearly stated and permanently displayed in the form of a notice in the machine room.

9 SPECIAL TECHNICAL REQUIREMENTS

The objective of this clause is to define some special type of lifts that are used currently in buildings such as lifts without conventional machine rooms (MRL lifts), lifts used in private apartments (home lifts), hydraulic type of lifts and lifts required for differently abled persons, etc.

9.1 Lifts Without Conventional Machine Rooms (MRL Lifts)

9.1.1 MRL lifts are a special type of lifts where hoisting machine is placed inside the lift shaft and control system may be inside and/or adjacent or at close proximity to top landing door, eliminating the need for conventional machine room.

9.1.2 The MRL lifts shall be in conformance with good practice [8-5A(10)] apart from other relevant provisions of this Section.

9.1.3 MRL lifts may be provided with emergency door on the top portion of the hoist-way which is equipped with electromechanical lock wired in series with lift safety chain and of size 700 mm × 700 mm minimum, so as to access the machinery space in case of emergency or safety device being activated on or above the top landing.

9.2 Lifts Used in Private Apartments/Houses/Villas (Home Lifts)

9.2.1 The home lift is designed especially for private home having up to 4 stops (maximum rise 12 m), where the usage of the lift is restricted primarily to the residents of the private home. Unlike conventional lifts which allow virtually unlimited access to members of the general public, in case of home lifts non-residents shall have limited access.

9.2.2 The rated capacity of the home lift shall be minimum 208 kg (3 persons) and maximum 272 kg (4 persons) and lift car speed shall not exceed 0.4 m/s.

9.2.3 The home lifts shall conform to good practice [8-5A(11)] apart from other relevant provisions of this Section.

9.2.4 Electric MRL type home lifts, shall in addition conform to the technical requirements specified in good practice [8-5A(10)].

9.2.5 Hydraulic type home lifts shall in addition conform to the technical requirements specified in good practice [8-5A(1)].

9.3 Hydraulic Lifts

9.3.1 The hydraulic lift is a special type of lift where the lift car is directly or indirectly driven by action of one or more hydraulic jacks.

9.3.2 The hydraulic lifts shall conform to good practice [8-5A(1)] apart from other relevant provisions of this Section.

9.3.3 These lifts should preferably be hole-less type of lifts.

9.4 Lifts Accessible for Persons with Disabilities

9.4.1 All lifts open to public shall adhere to the accessibility provisions in terms of size of the car, door width, control panel, flooring, finishes, handrails, communication systems and information, given in 13 of Part 3 'Development Control Rules and General Building Requirements' of the Code.

9.4.2 Lifts for persons with disabilities shall conform to good practice [8-5A(12)] apart from other provisions of this Section.

9.5 Seismic Resistance in Lifts

When seismic protection of the passengers and equipment is a consideration, the safety requirements and protective measures given below may be adopted, the specified requirements being applicable when the units are subject to seismic conditions where the specified design acceleration (a_d) $\geq 1 \text{ m/s}^2$:

NOTE — The design acceleration is a function of ground acceleration, soil behaviour, importance factor, etc. Thus, the value of (a_d) applicable to the building and to be considered for lift design/installation shall be provided by the building architect or structural designer to the lift manufacturer.

- a) *General* — Such lifts shall comply with the relevant safety requirements and/or protective measures of this clause to protect them when the lifts are subject to seismic conditions.
- b) *Lift well* — In order to prevent that suspension ropes, governor ropes, travelling cables, compensation ropes and chains swaying in the well getting entangled with fixed equipment, snag points created by brackets, sills, devices and other equipment mounted in the well shall be protected according to Table 25.
- c) *Machinery and pulley spaces* — Where buildings are designed with expansion joints

Table 25 Protection of Snag Points

[Clause 9.5(b)]

Sl No.	Height of the Well	Horizontal Distance of Snag Points	Protected Equipment	Measures	Construction Scope
(1)	(2)	(3)	(4)	(5)	(6)
i)	≤ 20 m			Not necessary due to very small shake (displacement) of buildings	
ii)	> 20 m and ≤ 60 m	< 900 mm	Travelling cables	Install protection measure for example, a protection wire in the corner of the rail bracket or other snag points near the travelling cables	Required, if any portion of the loop is closer than 900 mm from a snag point
		< 750 mm	Compensating chain(s), compensating rope(s), counterweight governor rope	Install protection measure for example, a protection wire in the corner of the rail bracket or other snag points	Full travel in case of installing either of the compensating chain or compensating rope or counterweight governor rope
		< 500 mm	Car governor rope	Install a rope guide and protector. Otherwise use protection wire	Full travel
		< 300 mm	Suspension ropes	Install a tape guide and protector. Otherwise use protection wire	Full travel
iii)	> 60 m	Protect all snag points independent of horizontal distance	Travelling cables, compensating chain(s), compensating rope(s), counterweight governor rope, car governor rope, suspension ropes	Apply protection measures	Full travel

subdividing the structure into dynamically independent units, all the lift machinery including the landing entrances and the well of the lift shall be located on the same side of an expansion joint.

d) *Car*

- 1) *Mass of the car for lift design calculations* — For lift design calculations, the forces generated by the design acceleration (a_d) shall be calculated taking into account the following:
 - i) For passenger lifts the mass of the car plus 40 percent of the rated load evenly distributed; and
 - ii) For goods passenger lifts the mass of the car plus 80 percent of the rated load evenly distributed.
- 2) *Car retaining devices* — The retaining devices shall be placed in such a way to distribute loads in a similar way as the guide shoes. The retaining devices shall either be integrated or mounted close to

the fixing of the guide shoes. When the car is center located between the guide rails the clearances d_1 , d_2 and d_3 (see Fig. 9A) between the retaining device and the guide rail shall not exceed 5 mm and the dimensions chosen shall not cause accidental tripping of the safety gear during an earthquake.

The depth of the retaining device (z_1) shall be limited to avoid collision with guide rail attachments or other fixed devices, but long enough to guarantee a minimum required overlapping length between retaining devices and the guide rail blade during an earthquake.

During an earthquake, the minimum required overlapping length between retaining devices and the guide rail blade shall be at least 5 mm (see Fig. 9B).

The car structure and retaining devices shall be sufficient to withstand the loads and forces imposed on them including forces generated by the design acceleration (a_d), without permanent deformation.

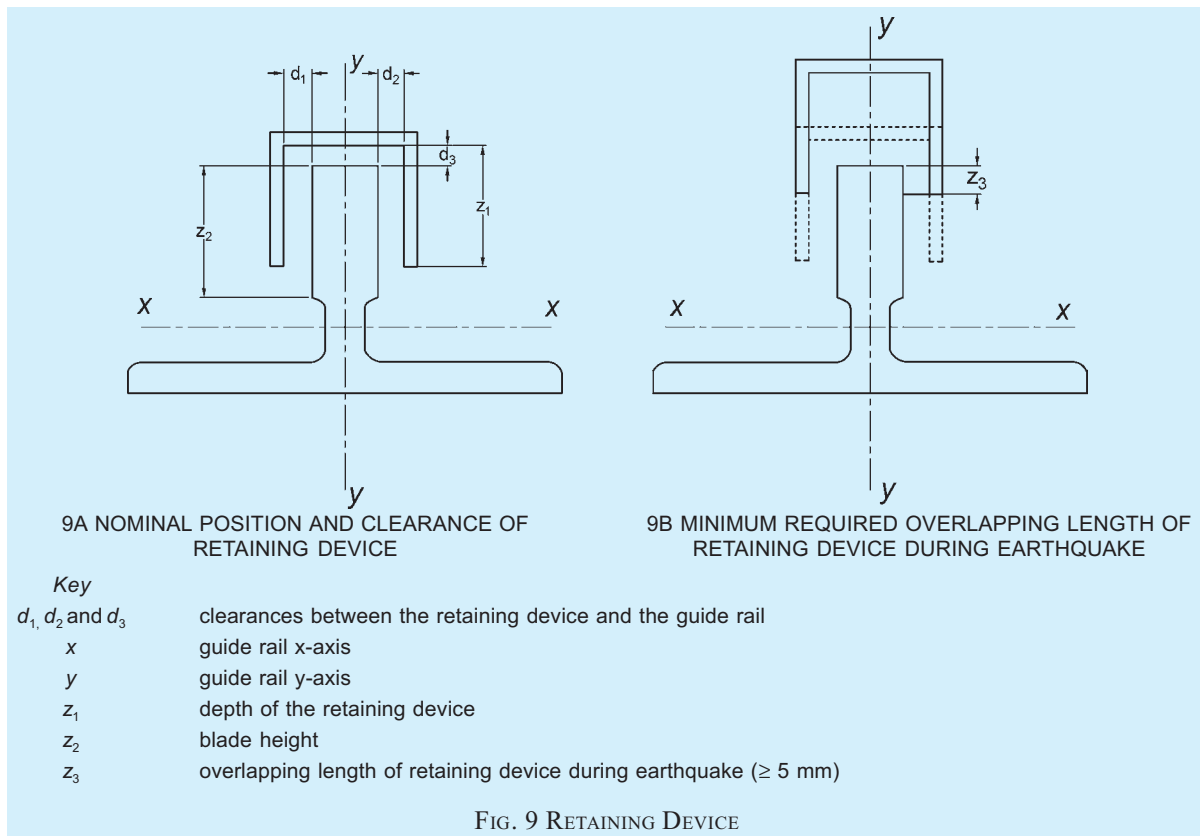

FIG. 9 RETAINING DEVICE

- e) **Counterweight** — The counterweight shall be provided with upper and lower retaining devices able to hold the frame in between its guide rails. The retaining devices shall be placed in such a way to distribute loads in a similar way as the guide shoes. The retaining devices shall either be integrated or mounted close to the fixing of the guide shoes. The retaining devices shall not exceed 5 mm. When a safety gear is present, the dimensions chosen for the clearances d_1 , d_2 and d_3 shall not cause accidental tripping of the safety gear. During an earthquake, the minimum required overlapping length between retaining devices and the guide rail blade side shall be not less than 5 mm (see Fig. 9B). The counterweight structure and retaining devices shall be sufficient to withstand the loads and forces imposed on them including forces generated by the design acceleration (a_d), without permanent deformation. The strength of the retaining devices and the counterweight frame shall be calculated taking into account the vertical mass distribution of its weight blocks. If the counterweight incorporates filler weights, necessary measures shall be taken to prevent their movement outside the frame considering the design acceleration value.
- f) **Suspension and compensation**
- 1) **Protection for traction sheaves, pulleys and sprockets** — The devices for preventing the ropes from leaving the grooves of traction sheaves and pulleys shall include one retainer no more than 15° from the points where the ropes enter and leave the grooves and at least one intermediate retainer every 90° of the angle of wrap. The strength and stiffness of the retainers and their distance to the traction sheaves and pulleys compared to the diameter of the ropes shall be such that they are effective. The devices for preventing the chains from leaving the sprockets shall include one retainer at the points where the chains enter and leave the sprockets.
 - 2) **Compensation chains** — Compensation chains or similar means shall be guided in the pit in order to limit them from swaying and reaching snag points.
- g) **Precaution against environmental damage** — Hydraulic lifts shall be provided with a rupture valve. The rupture valve shall comply with the requirements of 12.2 of good practice [8-5A(1)]. The space in which the hydraulic power unit is situated and the pit shall be

designed in such a way that it is impervious, so that all the fluid contained in the machinery placed in these areas will be retained if it leaks out or escapes.

h) *Guide rail system*

- 1) *General* — The guide rails, their joints and attachments shall comply with the requirements of good practice [8-5A(5)], and they shall also withstand the loads and forces generated by the design acceleration (a_d). Retaining devices shall be used as frame supporting points in the guide rail verification.
- 2) *Permissible stresses and deflections during seismic event* — With provision of retaining devices the requirements stated below shall be fulfilled. The safety factors for guide rails shall satisfy Table 26.

Sl No.	Elongation (A5)	Safety Factor
(1)	(2)	(3)
i)	$A5 \geq 12\%$	1.8
ii)	$8\% \leq A5 < 12\%$	3.0

For guide rails, the permissible stresses as given in Table 27 shall be used.

R_m (Tensile Strength of Guide Rail), N/mm ²	370	440	520
σ_{perm} (Permissible Stresses), N/mm ²	205	244	290

The maximum permissible deflection of car or counterweight guide rail in y-direction (see Fig. 10) shall be such that the overlapping length between the blade of the guide rail and the retaining devices is not less than 5 mm (see Fig. 9B). The maximum permissible deflection of the car guide rail, counterweight guide rail in x-direction (see Fig. 10) shall also be applied in y-direction. The maximum permissible deflection includes guide rail, its fixing bracket and separation beam, if used. For T-profile guide rails the maximum permissible deflection (in millimetre) (see Fig. 9A) is:

$$\delta_{perm} = z_1 - 2d_3 - 5$$

but never more than 40 mm.

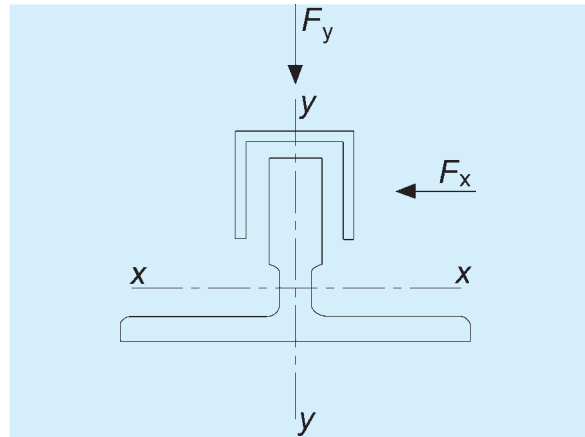

KEY:
 F_x = force exerted to the guide rail by the guide shoes or by the retaining devices in the x-axis.
 F_y = force exerted to the guide rail by the guide shoes or by the retaining devices in the y-axis.

FIG. 10 GUIDE RAIL AXIS AND FORCES

- j) *Machinery and other lift equipment* — All machinery including control cabinet(s) and drive system, lift machine, main switch(es), and means for emergency operations, cylinder and ram, pulleys and associated overhead beams and supports, rope attachments, over speed governor, tension pulleys and compensation rope tension devices shall be designed and anchored to prevent overturning and displacement as a result of the forces imposed on them including forces generated by the design acceleration (a_d).

Hydraulic lifts shall preferably use flexible pipe work but where the use of rigid pipe is essential it shall use flexible pipe at the end of each rigid length.

k) *Electric installations and appliances*

- 1) *Electric installations in the lift well* — The fixing of landing switch devices or final limit switches, vanes or similar devices fixed in the shaft shall be designed and installed to withstand the loads and forces imposed on them including forces generated by the design acceleration (a_d). In addition, the devices mentioned above shall be protected by guards against damage caused by ropes and cables swaying in the well.
- 2) *Behaviour of the lift in case of failure of the mains power supply* — In case of seismic events, in order to avoid people getting trapped in the car in case of failure of the normal power supply, the lift has to be able to move automatically, the car to the next landing in up or down direction.

At landing, the lift shall operate as described below:

- i) Lift with automatic power operated doors, when parked at a landing, shall open the doors, remove the lift from normal operation and keep the door open.
- ii) For a lift with manually operated doors, when the car arrives at the designated landing, its door(s) shall be unlocked and the lift removed from normal operation.

Where local regulations do not permit the doors to remain open, a means shall be provided to open the doors (even with the electrical power on) enabling the rescue service to check whether the car is present and persons are not trapped.

The behaviour of the lift in case of failure of the normal power supply shall not override any of the following:

- a) The electric safety devices.
 - b) Inspection operation.
 - c) Emergency electrical operation {see 9.5 of good practice [8-5A(6)]}.
 - d) The fireman's lift switch {see 8.3.14 of see good practice [8-5A(7)]}.
- 3) *Seismic detection system* — A seismic detection system shall be provided for lifts manufactured with design acceleration $a_d \geq 4 \text{ m/s}^2$. For lifts manufactured with $a_d < 4 \text{ m/s}^2$ the provision of seismic detection system is optional.

NOTE — The scope of supply for seismic detector and wiring from the detector to the lift control panel should be discussed between the building owner or his representative, and the lift manufacturer.

Where the seismic detection system is used exclusively to send information to the lift it may be placed in the pit of the lowest lift in the building. In case of expected interference with other vibration sources, alternative locations of the seismic detection system are allowed.

The seismic detection system shall comply with the following:

- i) *Detection of tri-axial acceleration* — The seismic detection system shall be able to operate at all times when the lift is intended to be available to users.
- ii) *Seismic trigger level* — It shall be less than or equal to 1.00 m/s^2 in any direction including vectors.

NOTE — 'Vector' relates to the resulting acceleration from combined reactions in x, y and z planes.

- iii) *Frequency response* — It shall be between 0.5 Hz and 10 Hz.
 - iv) *System reaction time* — The system reaction time shall not exceed 3 s. The system reaction time describes the maximum allowed time period between the point in time when the seismic wave exceeds the selected seismic trigger level for the first time and the point in time when the lift switches into the seismic mode.
 - v) *Automatic system test* — The seismic detection function including interface between seismic detector system and the controller shall be tested automatically every 24 h. If a failure is detected during the test, the lift shall remove itself from normal operation on its next stop at a landing and park with its doors open.
 - vi) *Emergency electrical power supply* — The operation of the seismic detection system shall not be impeded or lost even in case of electrical power supply switching or mains power supply failure. When an emergency electrical power supply is used it shall be able to provide at least 24 h of power supply.
 - vii) *Resetting of the seismic detection device* — The resetting of the seismic detection device and the return of the lift to normal operation shall only be made by operation of manual reset devices. The manual reset device of the lift shall be placed outside of the well, clearly identified, and accessible to authorized persons only (maintenance, inspection and rescue), for example inside a locked cabinet.
- 4) *Behaviour of the lift in seismic mode* — After activation of the seismic detection system, the lift shall perform as described below:
- i) All registered car and landing calls shall be cancelled. New calls shall be ignored. A lift in motion shall reduce the speed or stop and proceed to the next possible landing away from the counterweight or balancing weight with maximum 0.3 m/s car speed.
 - ii) When lift is at landing, a lift with automatic power operated doors shall

open the doors, remove the lift from service and keep the doors open; and a lift with manually operated or non-automatic power operated doors shall remain in this condition and be removed from service with the doors unlocked.

Where local regulations do not permit the doors to remain open, a means shall be provided to open the doors (even with the electrical power on) enabling the rescue service to check whether the car is present and persons are not trapped. In case of failure of the normal power supply the lift shall operate as described in 9.5(k)(2).

9.6 Automobile lifts

Where required, lifts suitable for moving passenger vehicles such as light motor vehicles (LMV), small utility vehicles (SUV), etc may be provided. The minimum requirements to be considered while providing such lifts are as given in 9.6.1 to 9.6.8.

9.6.1 The minimum and maximum car area requirements for passenger lifts as defined in 6.1 of [8-5A(6)] may not be applicable for automobile lifts. For this class of loading, the rated load shall be based on not less than 1.45 kN/m² of inside net platform area.

9.6.2 Strengthening stiffeners may be added to car panels to have sufficient strength to avoid permanent or temporary deflection of car panels beyond limits in case the vehicle touches the lift car panels while moving in or out. Under no circumstance, it should result into unsafe condition.

9.6.3 The hall button for calling the lift may be provided in the approach way at such a location that the button is accessible to the vehicle driver in the driving position without having to get off the vehicle. Optional light ray detection system or card reader system may be provided for automatic detection of vehicles and calling the lift to the floor.

9.6.4 Minimum entrance width of such lifts may be 2 400 mm and entrance height of 2 300 mm. The minimum car inside dimensions may be 2 500 mm wide and 5 300 mm deep and typically with entrance doors on both sides of the lift. This will enable the car to be driven inside and can be taken out in the same direction, without any need to reverse the same. Minimum load carrying capacity shall not be less than 2 500 kg.

9.6.5 Barricades may be provided outside the lift entrance door(s), so as to limit the size of the vehicle and preventing oversized vehicles from entering the lifts and possibly damaging the equipment.

9.6.6 There shall be sufficient place on both sides of the vehicle, once the vehicle is inside the lift. The lift

car width should be selected such that in case of emergency while the automobile is in the lift car the driver should be able to open the automobile door and come out of the automobile.

9.6.7 The car operating panel, where the car call can be given, may be provided at such a location that is accessible by the vehicle driver in the driving position without having to get off the vehicle. The time duration for which the door remains open upon arrival at landing floor or upon stopping at landing floor shall be sufficient enough so as to enable smooth movement of the vehicles in and out of the lift car. Lift car entrance door(s), shall be equipped with light curtain device in accordance with 19.1.4 of good practice [8-5A(5)].

9.6.8 Overload warning device shall be installed in accordance with 6.2 of good practice [8-5A(6)].

9.7 Air Conditioning System for Lift Cabin (Car)

Where the lift car is equipped with air conditioning system, following additional requirements are recommended:

- a) The whole equipment, its container, condenser, etc, should be typically made of corrosion resistant material, with average designed life span of 10 years.
- b) The air conditioning system should work on single phase electric power supply of maximum 230 V a.c. and should be well within the current carrying capacity of trailing cable cores provided for the air conditioning system. The power supply for the air conditioning system shall be provided from RCCB of suitable rating. This RCCB shall be located in the lift machine room with proper identification and lock out tag out facility.
- c) The air conditioning system should be provided with suitable air filters which should ensure clean air inside lift car. The filters should be easily accessible and serviceable from top of the lift car in a safe and easy manner.
- d) The lift air conditioning should typically include functions such as:
 - 1) Cooling, with adjustable temperature setting provided on the unit itself or through remote control unit, which may be maintained in the lift car.
 - 2) Heating, with adjustable temperature setting provided on the unit itself or through remote control unit may be maintained in the lift car.
 - 3) Ventilation, with adjustable air flow having less than 52 dBA noise level in the car.

- 4) De-humidification, with effective condensation water management system.
- e) The lift air conditioning should be equipped with effective condensation monitoring and condensed water recycling system so as to avoid water spillover or leakage on top of the lift car and other lift components.
 - 1) Condensation water monitoring and dealing with it is a very important feature any lift air conditioner shall have. Condensation water leakage or spillover on the lift car top may cause damage to the lift and may lead to electrocution or even fire.
 - 2) When the condensation water level in the reservoir reaches high level and remains at that or above that level for three minutes, the compressor should stop working and the air conditioner should go into ventilation mode. In the ventilation mode the air conditioner fan still works, water pump still runs, the water is pumped to the condenser for condensation water to be vaporized. When the water goes below 80 percent, the compressor may restart and the air conditioner may go into cooling mode.
 - 3) When the condensation water level reaches 100 percent, and remains at that level for 1 min, to avoid the water spill over and damage to lift components, the air conditioner should power off by itself. All components of air conditioner should stop working. This air conditioning unit shut down should not be automatically resettable and should require manual intervention. Also it should be possible for this condensation water to be drained out by opening the drain plug provided. This facility of draining off excess condensation water shall be safely accessible either from lift car or lift pit.
- f) It shall be possible to manually switch 'ON' and 'OFF' the lift air conditioning unit either by key switch provided in the lift car or by remote control.

9.8 Lift Interface with Building Management System (BMS)

Where required, a means to interface, monitor and control be provided by lift manufacturer, which should become the part of building management system. The following information and controls, but not limited to those, may be provided either through potential free contacts or building automation (BA) interface device

suitable for providing necessary lift information over other accepted communication protocols. With potential free contacts only lift monitoring is possible. It shall not be possible to control the lift.

- a) *Monitoring signals*
 - 1) Floor position of the lift for each lift.
 - 2) Direction of travel for each lift.
 - 3) Load condition of each lift specially indicating overload status.
 - 4) Lift door status of each lift, whether open or closed.
 - 5) Lift modes such as attendant, automatic, independent operation, emergency fire service, seismic mode, emergency medical service and inspection mode for each lift.
- b) *Control signals*
 - 1) Bring the lift down to lobby floor in case of emergency or VIP movement.
 - 2) Park and shutdown lifts based on building and traffic requirements, so as to save power.
 - 3) Force the lift into emergency fire service, seismic mode or emergency medical service, etc through command from BA system based on respective sensor's such as smoke detectors, seismic sensor, etc, input to BMS.
- c) *Reports* — Software tools may be developed to report out performance of each lift such as average response time, number starts per hour, average lift uptime, round trip time, etc. Flexibility to provide additional reports based on building requirements.

The above mentioned requirement for potential free contacts, other standard protocols, etc, may be optional, if the full-fledged lift management system software is provided by lift manufacturer for monitoring and control of lifts in the building. This software may be custom built providing above mentioned requirements. The wiring between lift machine room to Building Management Systems shall be planned and carried out by the builder along with other wiring in the building.

9.9 Closed Circuit Camera Inside Lifts for Monitoring (CCTV)

Where required, closed circuit camera is provided either by lift manufacturer or by third party supplier, inside the lift car for security purposes. Suitable warning mentioning 'You are under CCTV surveillance' shall be posted inside the lift car. These cameras may be located at ceiling level and at any location which cannot be easily accessed, noticed or tampered with.

The cable used for connecting in car camera to monitoring system, provided by supplier, shall be of trailing grade. Ordinary co-axial or twisted pair wires shall not be lashed or tied along with trailing cables. Trailing cables are specialized cables used in lift applications. Wireless CCTV may also be considered alternatively.

If the camera signal is disconnected, either because of fault or intentionally, the lift monitoring system should get an alert indicating the same. Responsibility of monitoring, recording, organizing and maintaining CCTV shall be duly decided in advance.

9.10 Emergency Medical Service (EMS) for Hospitals

Optional emergency medical car operation may be provided especially for hospitals and operation theatre lifts and the lift behaviour in this mode is as described below. Activation of the emergency medical hall switch activates the in-car buzzer and illuminates a lamp in the car and hall. This forces the car to cancel car calls, reassigns hall calls, and return non-stop to the defined medical landing. Upon arrival, the door opens and the buzzer is deactivated.

The door remains open until the switch is turned off or the doors have been open for at least 60 s. If the medical switch is toggled, this operation remains in effect for additional 60 s. The second phase of EMS operation can only be activated when the doors are open at the medical landing. Once the car is on emergency medical operation fire service operation cannot be initiated, even though the fire service lamp and buzzer are activated.

If the car is performing fire service operations, emergency medical operations cannot be initiated, even though the medical lamp and buzzer are activated. The car automatically enters the emergency medical car operation after the doors are open at the medical return landing. If the emergency medical car switch is not activated within 60 s, the medical operation is cancelled.

To move the car, the emergency medical car switch needs to be activated. Prior to activation, the door cannot be closed and car calls cannot be registered. An active car switch allows car calls to be registered, which automatically closes the door and moves the car to the target landing. At the target landing the door opens and remains open until another car call is registered. The door close button has no effect on this operation.

If the car medical switch is deactivated away from the medical return landing with the doors open, the car remains at the landing not allowing car calls to be registered or the door to be closed. The car shall be returned to the medical landing and the emergency medical car switch deactivated to remove the car from emergency medical car operation.

9.11 Destination Control System (DCS)

The destination control system (DCS) uses passenger destination information to improve traffic flow and travel time in busy mid- and high-rise buildings. Instead of using standard hall call buttons, passenger enters specific floor number he wants to travel to — before entering the lift. The system groups passengers traveling to nearby floors to the same car.

Conventional Destination Control System requires keypads or touch screens at all floors to book the calls. This conventional DCS may be additionally provided the car operating panel (COP) in the lift car to improve passenger comfort. Alternatively, the COP in the lift car may be hidden. Traditional hall lanterns are no longer needed.

Hybrid Destination Control System requires keypads or touch screens only at the main floor allowing up-peak boosting of traffic. Traditional hall button stations and hall lanterns need to be provided at all other floors. A full COP is required in the lift. With both conventional and hybrid DCS provided with touch screens and/or keypads, hot button(s) may be provided to facilitate call booking to common floors as fast as possible.

Optional system features may be customized to meet building needs for special recognition to some passengers (VIP, special service, building service personnel). A security interface may be provided to allow for integration of building security and lift-dispatching systems.

Additional requirements for lifts required for persons with disabilities shall be according to requirements of good practice [8-5A(12)]. Fireman's lifts shall be provided with full car operating panel (COP) irrespective of configuration used.

9.12 Special Environments

Standard equipment is suitable for use inside normal residential, commercial and industrial buildings but when unusual environments are likely to be encountered, the advice of the lift manufacturer should be sought at the earliest possible stage to enable the most economic satisfactory solution to be found. Special mechanical protection and or electrical enclosures may be necessary as well as compliance with statutory or other regulations and with the purchaser's particular requirements, which should be fully considered at the time of enquiry.

Examples of situations which necessitate special consideration are:

- a) Exposure to weather, for example, car parks.
- b) Low temperatures, for example, cold stores.
- c) High temperatures, for example, boiler plant.

- d) Hosing-down, for example, for hygiene or decontamination.
- e) Corrosive atmosphere, for example, chemical works.
- f) Dusty atmospheres, for example, gas plant.
- g) Explosive and inflammable atmosphere, for example, gas plants, and petroleum and polyester industries.
- h) Nuclear/heavy water plants.

10 PERFORMANCE REQUIREMENTS FOR LIFTS

10.1 It is necessary to have uniformity in the definition, measurement, processing and expression of vibration and noise signals that comprise lift ride quality. The aim of such uniformity is to benefit users by reducing variability in the results of lift ride quality measurements caused by differences in the methods of acquiring and quantifying the signals. Experience indicates that evaluation of vibration in terms of peak-to-peak levels is of particular relevance to passenger comfort. It is considered necessary to provide a dual form of expression, quantifying both the maximum peak-to-peak and A95 peak-to-peak vibration levels.

10.2 Measurement of Lift Ride Quality

Ride quality of all lifts shall be measured in accordance with accepted standards. The selection and calibration of measuring and test equipment shall also be in accordance with accepted standards.

Measurements shall be made during normal building conditions, after the lift has been running under normal daily operation for at least one hour. Vibration measurements shall be made at the geometric center of the car.

11 SPECIAL TECHNICAL REQUIREMENTS FOR SUPER HIGH RISE BUILDINGS

The provisions given hereunder describes the different physical phenomena that occur in super high rise buildings (> 200 m high) and have an effect on vertical transportation solutions.

Although there are no major differences with regard to suspension and guidance systems between high-rise and low-rise lifts, there are other aspects to be considered such as system technology and passenger comfort levels. Control system artificial intelligence levels, safety requirements, load-bearing component ratings, rope weight, energy consumption, and thus cost increase exponentially with the height of the building.

11.1 Air Pressure Effect

In high rise buildings, air pressure is different on ground level and on top of the building. Practically, pressure change on the ear becomes uncomfortable for some persons when lift is landing faster than 10 m/s. The thresholds are lower for small children, elderly persons

and passengers having flu. Therefore, practically, lifts are offered as a standard solution up to 10 m/s maximum.

11.2 Piston Effect

If high speed lifts especially those having rated speed greater than or equal to 4 m/s, are housed in single shaft, the displaced air due to movement of the lift car tries to escape through the gaps between the lift car walls and the shaft walls in turbulent flow. This phenomenon known as piston effect causes the quality of ride in the lift car to deteriorate. Noise level in the lift car may increase along with vibrations which will be felt by the passengers. The air being displaced past the car generates whining and whistling noises inside the car. Buffeting when passing doors may be audible and passenger may feel uncomfortable. Both lift car doors and landing doors may whistle at high speeds.

Therefore, high speed lifts should preferably be housed in common shaft with ventilation holes in the common wall(s), if any. These holes allow the air displaced due to the movement of the lift car to escape in the adjoining hoist-way. Thus, the velocity of the escaping air which depends on the ratio of the lift car area to lift shaft area reduces which mitigates the piston effect ensuring good ride comfort for the passengers. The size of the vent and the pitch at which the vents need to be provided depend on lift car size in relation to lift shaft size, as well as the speed of the lift and the ride comfort expected.

In addition, high speed lifts especially those having rated speed more than 6 m/s may be provided cars with aerodynamically designed exteriors. This special construction of the car however increases the requirements of the overhead and pit for which lift manufacturer should be consulted. To reduce hammering sounds caused by the passage of the lift past the landing doors, shaft in front of the lift car door may be clad with fascia plates of full shaft width between the landing door sill of the upper floor and door header of the lower floor door to create an even, flush surface. Lift cars also need to be specially constructed to absorb noise and thus reduce transmission of noise in the car.

It is advisable not to have common wall between the lift shafts. There should be shaft divider beams provided at every floor level and in between floors, if required, for the support of the guide rail brackets. Metallic wire mesh shall be provided for separation of shafts.

11.3 Stack Effect

Stack effect is defined as the vertical, natural air movement throughout a high rise building caused by the difference in temperatures between the inside air and the outside air. Positive stack effect is characterized

by a strong draft from the ground floor to the roof. Positive stack effect is more significant in cold climates because of the greater difference in temperature between the inside and the outside of the building. The colder the weather and the taller the building, the greater will be the stack effect. Negative stack effect can also occur in the reverse direction in hot climates, but is not as significant because the difference in temperature is not as great.

The magnitude of stack effect is a function of,

- a) building height;
- b) air tightness of exterior walls;
- c) air leakage between floors; and
- d) difference in temperature between inside air and outside air.

The stack effect has following effects:

- 1) *Differential pressure on the lift landing doors* — The stack effect generates differential pressure on the landing doors. In case of buildings with airtight separation of each story the differential pressure on a particular landing door from inside and outside of the lift shaft is small however the pressure on the door of the first landing and that on the last landing varies a lot.

In case of buildings with no air partitions the converse is true. The differential pressure on a particular landing is significant and is the maximum at the top most and bottom most landings which are farthest from the neutral pressure level. At the neutral pressure level, which occurs somewhere in the mid of the building height, the differential pressure on the landing door from inside and outside of the lift shaft is nil.

The differential pressure on the landing door may cause difficulty in the operation of the door.

- 2) *Smoke movement* — The stack effect influences the smoke movement. In case of positive stack effect the air moves out from core of the building towards the exterior of the building above the neutral pressure level and it moves in from the exterior of the building to the core of the building below the neutral pressure level. In case of negative stack effect, reverse phenomenon occurs.

This air movement naturally affects the smoke movement in case of fire and has to be taken into account.

Since stairwells, lift shafts and lifts tend to contribute to the stack effect it is essential that all lift lobbies are well sealed and lifts parked

with door closed to minimize stack effect. Especially in case of fire the stack effect needs to be controlled to prevent the spread of smoke in the building. On the other hand, the stack effect may be beneficially used to quickly drive smoke out of the building in case of fire.

11.4 Building Sway

The wind induced sway of the building may cause the lift suspension and/or compensation ropes and lift car travelling cables to sway. Buildings have natural frequencies of oscillations. Similarly lift ropes also have natural frequencies of oscillations which depend on the position of the car in the hoist-way amongst other parameters. When natural frequencies of the ropes and the building match, a large amount of energy is transferred to the ropes and they start swaying violently. This results into reduced ride comfort for the passengers in the lift and increases possibility of ropes getting stuck to snag points in the shaft and damaging shaft equipment. In general, the rope and travelling cable resonance phenomenon should be taken into account in the lift design for over 200 m in height buildings and slender buildings over 150 m in height, for example, TV towers. It is a fact that the resonance cannot be completely avoided in high rise buildings, hence the need for the solutions to cope with the phenomenon. If resonance is not taken into account in the lift design, it could increase the lift out-of-service time and decrease lift ride comfort.

The main purpose of the sway management is to improve lift safety and service time by reducing rope sway by optimizing compensations ropes tension, providing shaft protection equipment to prevent ropes from entangling and damaging the lift equipment. A sway detector may be used to control the lift operations. The output signals from the sway detector are used to reduce the speed of the lifts or park them at a safe floor.

In order that the sway analysis is done, the building designer should be in touch with the lift designer since early design stage of the building and share information on the building natural frequencies, maximum amplitude of building displacement with probability of occurrence, etc. The lift designer would then be in a position to calculate the rope/cable sway and decide on the preventive measures to be taken in the lift design.

11.5 Ride Comfort

A robust car guidance system with meticulously aligned guide rails is essential for reducing vibrations to an acceptable comfort level. Guide rails shall be rated for heavy-duty usage. Irregularity in the guidance system causes an unpleasant and uncomfortable transverse vibration within the car at high speeds. High-quality roller guidance system is required for smooth ride. In

addition, the lift guidance system shall be able to withstand the effects of the building settling and the response of the building's structure to thermal and climatic changes.

11.6 Jump Lifts

In super high rise buildings there may be a need to start lift erection before the machine room is finished in order to compress total time required to complete the building. The self-climbing lift technique may be used to build the lift as the building construction progresses. Jump lift uses a temporary machine room that is moved upward as construction progresses. Typically, when the building construction reaches 7th floor, the jump lift may start operating and start serving lower floors. Exterior hoists can be removed sooner, enabling the façade to be enclosed. This means that lower floors are ready for finishing much earlier and the entire building can be completed sooner. Since all transportation takes place in a dry, windproof shaft, construction can continue safely and unhindered, even in bad weather. The change-over to final lift is very quickly done.

12 LIFT ENQUIRY OR INVITATION TO TENDER

12.1 General

A period of two to four weeks is normally sufficient for return of tenders. This should be extended, if large numbers of lifts or special requirements are involved.

The enquiry documents should be kept to the essential minimum, and should be strictly confined to material relevant to the lifts works and to the particular project concerned.

When enquiring for and ordering lifts, the particulars given below should be furnished:

- 1) Type of lift (passenger, goods, service or dumb waiter);
- 2) Number of lifts required;
- 3) Capacity/Load of lift (s): number of persons (in kg);
- 4) Rated speed (m/s);
- 5) Travel (in m) and building height;
- 6) Floors served (no. of regular openings, emergency openings, blocked openings);
- 7) Method of control (simplex or group control);
- 8) Position of machine room (if machine room-less, machine below, hydraulic);
- 9) Machine room height;
- 10) Clear overhead/Clear top clearance;
- 11) Pit depth;

- 12) Sizes of hoistway (width x depth), in mm;
- 13) Position of counterweight;
- 14) Car size (width x depth), in mm;
- 15) Construction, design and finish of car bodywork;
- 16) *Car entrances:*
 - i) Number of entrances,
 - ii) Size (width × height), in mm
 - iii) Type of door (center opening, telescopic, 4 panel, vertical bi-parting), and
 - iv) Whether through opening.
- 17) Car light;
- 18) Call indicator;
- 19) Position indicator in car;
- 20) *Lift landing entrances:*
 - i) Number of entrances,
 - ii) Size (width × height), in mm
 - iii) Type of door or gates or shutters (for goods lifts) (centre opening, telescopic, 4 panel, vertical bi-parting), and
 - iv) Whether through opening.
- 21) *Electric supply:*
 - i) Power in volts a.c.,
 - ii) Phase, and
 - iii) Cycles (wire system).
- 22) Whether neutral wire available for control circuit;
- 23) Temporary guarding of hoist-way and car cabin;
- 24) Lighting volts a.c./d.c.;
- 25) Are premises subject to *Lifts Act* and *Rules*;
- 26) Disable friendly requirements [such as voice announcement of floor levels, accessible control panel (good contrast with the background wall, Braille, raised letter and font), railing on three sides, two way accessible communication system];
- 27) Earthquake protection requirements; and
- 28) Additional items.

12.2 Additional Items

The enquiry should state any additional items required beyond those specified in good practice, such as interface requirements, dismantling of existing lifts, fireman's control, seismic design consideration, sway/deflection requirements, gravity distortion, etc.

12.3 Finishes

Finishes should be specified at the enquiry stage or provisional sums should be included for them. Finishes to be considered may include interior car finish, false ceiling design, false ceiling lighting, flooring material

and weight, blower, ventilation details, car wall cladding details (weight to be considered), multimedia display details (like screen type, size, location, etc), door cladding details, transom details (flushed with the wall, material type, etc). *See also 13* of Part 3 'Development Control Rules and General Building Requirements' of the Code.

12.4 Inclusions and Exclusions

A number of peripheral items are associated with lifts installation, of which some should always be provided by the builder and some are best included by the manufacturer. The requirements vary to some extent with the type of installation.

It is important that the limits of responsibility are clearly understood, and the enquiry documents should be specific in this respect.

The lifts manufacturer should include such items mentioned in 12.1.

The lifts manufacturer should exclude the supply and fixing of the items or as per the contract conditions as follows:

- a) Builder's work such as forming lift well, pit and machine room, and building wall inserts.
- b) Machine room floor including any reinforcement necessary for load bearing.
- c) Hoisting hook/lifting beam fixing, where necessary.
- d) Any necessary tanking, lining or reinforcement of the pit.
- e) Diving beams for multiple wells and inter well pit screen (or as per the contract).
- f) Trap door.
- g) Intermediate beams for bracket fixing.
- h) Door cladding (or as per the contract).
- j) Cutting away and making good.
- k) Working lights/permanent electricity supplies.
- m) Site painting of steel work other than lift material (if any).

For more detailed discussion of the requirements for site preparation and work by other trades, reference should be made to good practice [8-5A(7)] and to other relevant clauses of this Section.

Facilities for the use of the main contractor's crane should be provided to assist in installing heavy equipment in addition to other unloading facilities on site in the course of erection.

The main contractor should be instructed to include these facilities in his own quantities.

Where the lift manufacturer agrees to use mobile platforms in place of lift well scaffolding, the general contractor should provide 400/440 V 3-phase and 200/

220 V single-phase supply in the lift shaft to operate such equipment, the supply to terminate at the position in the lift well required by the lift manufacturer.

These mobile platforms are limited in use for erection personnel and the transportation of light equipment only, but use of crane will also be necessary to assist in the installation of the heavy machinery and also in the initial installation of the mobile platform equipment.

12.5 Site Programme

The enquiry should indicate as accurately as possible the contract programme as it affects the manufacturer, in particular the target date for completion, construction schedule, site preparedness, the availability of crane for hoisting, coordination details (with other contractors like BMS interfacing, CCTV interfacing, etc).

13 ACCEPTANCE OF TENDER AND SUBSEQUENT PROCEDURE

13.1 General

The procedure indicated below particularly relates to the most usual case, where the lift manufacturer is the sub-contractor.

13.2 Order

The building owner places an order with the selected contractor for supply and installation of lifts. If alternative schemes have been offered, the order should clearly indicate which has been accepted.

13.3 Programme

The contractor shall submit a detailed programme after acceptance of the order showing his intended method, stages of the works, together with the period of time that has been estimated for each and every stage of progress.

The programme shall cover each lift separately, including dates, such as:

- a) Date of order of equipment and materials;
- b) Date of commencement and completion of every stage of the works in line with the building construction programme;
- c) Date of expected completion of builder's work requirements;
- d) Date of delivery of equipment and materials to site; and
- e) Date of requirement of temporary and permanent electricity supply, and date of completion, commissioning and testing.

The period between order and delivery of material falls into two stages: first the finalizing of details and secondly the actual production of the equipment which

depends on the first stage. Within the first stage, other dates may need to be considered, such as:

- 1) All relevant building information available.
- 2) Submission of lift manufacturer's drawings.
- 3) Approval of drawings.
- 4) Final selection of finishes.

13.4 Drawings to be Submitted after Placing of Order

The lift manufacturer shall prepare layout drawings based on the civil/structure drawings, order requirements and submit to building owner within mutually agreed time frame. The same shall be briefed to building owner.

The drawings shall indicate clearly the position and sizes of all holes and cuttings, the loads on beams and structures, and all other requirements in relation to 'Lift Installation' namely:

- a) Lift machine room and associated equipment, including sub-floor where appropriate.
- b) All structural openings, such as landing entrances (including structural dimensions), ventilation openings, etc.
- c) All bases, plinths, channels, holes, grouting-in of fixings, etc.
- d) Lifting beams or other facilities for supporting lifting tackle in the machine room and lift well, permanent means of access to the lift pit.
- e) Hoisting facilities and access required for delivery of equipment to the machine room, etc.
- f) Details of structural steelwork for lift machinery in the lift machine room.
- g) Details of shaft dividing steelwork for supporting guard brackets etc, and inter-well screens/wall for multiple wells.
- h) Method of fixing guide rails.

13.5 Approval of Drawings

The building owner should go through the drawings submitted by lift manufacturer and ensure that it is prepared in line with civil/structural drawing and order requirements provided.

If any addition/alteration is noted in the drawing, the same shall be updated in the drawing by the lift manufacturer and resubmitted to the building owner for approval.

The drawing shall be approved by building owner, once it has been clearly understood.

13.6 Selection of Finishes

Where the contract provides for the purchaser's choice of decorative finishes, colours, etc, the decisions should

be communicated by the purchaser's representative as early as possible, preferably not later than the time of approval of drawings.

13.7 Electricity Supply to Lift

Operation of the machine under power is required from a comparatively early stage of installation for the most efficient working, and power supply should be provided accordingly. Whilst temporary supply may be sufficient for erection purposes, final testing and setting up can only be carried out with the permanent supplies connected. For this reason the timely provision of the permanent supplies is important.

14 COORDINATION OF SITE WORK

14.1 Preparatory Work on Site

In accordance with the general arrangement drawing for the lift, the representative of the lift company would brief the building owner or his nominated representative about the preparatory work that is required to be carried out before commencement of the lift installation.

The building owner will ensure that the preparatory work is done in accordance to the general arrangement of lift and also the state *Lift Rules* are followed for the construction of the lift shaft as well as machine room. Once the preparatory work is completed, the building owner or his nominated representative, will ask the lift company to cross check and see that everything is in order.

The representative of lift manufacturer shall check the lift shaft and bring the shortfalls, if any, to the notice of the building owner till the preparatory work is completed in compliance with the requirement of lift supplier. The following works shall be completed by the building owner before commencement of lift erection.

- a) Lift well pit floor and side wall of the lift shaft may be plastered and water proofed. Pit shall be free from any water leakage/seepage and debris. Building owner shall ensure the construction of the pit depth in accordance with the speed of the lift as specified by the manufacturer in the general arrangement drawing.
- b) In general the thickness of lift walls should be minimum 230 mm in brick or 150 mm in RCC. However, the lift shaft walls shall be constructed in consultation with structural engineers or consultant to verify the suitability based on lift load/reactions.
- c) In case of brick walls it would be recommended to have concrete block at locations where the guide rail brackets are to be installed. Similarly in case of structural shaft suitable ISMC/ISMB should be provided by the builder to fix guide rail brackets at all bracket fixing levels. The lift manufacturer

will provide a drawing indicating the locations of brackets in the lift shaft.

- d) Similarly for fixing the landing entrances, the builder has to provide RCC lintels/RCC beams for fixing landing door header and sill. In case of structural shaft suitable metallic channels have to be provided in the entrance area at lintel and floor level.
- e) All the structural shafts have to be completely covered and finished in accordance to the local codes before the start of installation.
- f) Suitable cut-outs near the entrance area as indicated in the lift general arrangement drawing have to be provided for fixing human interface system like landing operating panel, floor indicator, hall gong and lantern, emergency alarm, fireman switch and other devices like 'THIS CAR NEXT', group indicators, etc.
- g) The building contractor shall provide load hooks/beams in machine room for machine room lift, one directly above the lift shaft and other directly on top of the trap door as specified in the lift general arrangement drawing. The same shall be provided in the slab in the overhead area for machine room less lifts, as specified by the lift manufacturer in their general arrangement drawing. The position of load hooks/beams provided by the building contractor shall be as specified by the lift manufacturer.
- h) Machine room door shall be opening outside. It shall be minimum 1 m wide and 2 m in clear height with a platform outside.
- j) Caution notice of 440 V and restricted entry shall be marked on the machine room door.
- k) Fire extinguisher shall be provided by building contractor to prevent fire accidents.
- m) The machine room shall be air-conditioned or adequately ventilated so as to maintain the ambient temperature between +5°C and +40°C.
- n) The lift shaft in masonry shall be fully plastered. The shaft shall be given two coats of white-wash.
- p) Scaffolding (bamboo/steel) shall be erected as required by the lift manufacturer with necessary safety measures. Adequate barricading needs to be provided on all the lift entrance opening to avoid mishap.
- q) The building contractor shall provide proper illumination in the lift shaft, lift lobby, staircase and machine room.

14.2 Delivery of Material

The delivery of the material shall be made based on mutual agreement of the lift manufacturer and the building contractor. It is strongly recommended that the material should be delivered at site only when a suitable storage area is provided by the building contractor.

The scope of unloading and stacking materials shall be as per mutually agreed terms between the lift manufacturer and the building contractor. While unloading and shifting of materials due care shall be taken by both the parties to ensure safe unloading and shifting of materials.

Suitable equipment like hydra, fork lift, crane and trolleys shall be used for unloading and shifting of lift materials. Building contractor shall ensure safe passage for vehicles carrying materials, up to the storage area.

14.3 Storage

In order to enable efficient material distribution it is important that the material shall be unloaded from the delivery truck within a distance of 50 m of the storage/ unit location and have proper access from unloading area to storage area. The building contractor shall provide the storage area near the installation site, that is within 20 m distance from the installation site. The minimum storage space per lift shall be 35 m² per lift.

The storage room should be dry, well lit, weather protected and should have locking arrangement and provision of a 16 A power point is recommended. The storage area provided by the building owner should have PCC flooring. The storage room shall be kept ready before arrival of material at site and will remain in possession of installation engineer till the erection of lift is completed and handed over to the owner.

The material shall be stacked in sequential manner, in accordance with the planned activities. The storage area should be provided at a suitable location near the vicinity of the lift shaft preferably above the ground floor level and should remain in possession of the lift supplier till the installation and commissioning work is completed. It is strongly recommended that the location of the store is not changed to avoid material damages.

14.4 Site Meetings

For the successful progress of the work, full cooperation among all agencies is essential. In large sites, regular meetings of such agencies are beneficial for coordination of work efficiently. Programme for the constructional work in that part of the building

containing the lift should be made in consultation among all parties concerned.

14.5 Service of Other Trades

The lift erector will require the services of architect, civil, and electrical contractors, and other agencies as the work proceeds, and it is essential that the lift erector should give due notice to the building contractor of the demands to be made on other trades, so that he can plan accordingly. Mutually agreed, periodic meeting to review work progress with agencies concerned would ensure better coordination and efficiency.

14.6 Scaffolding, Fencing, Wherever Provided

Scaffolds and stationary work platforms shall be erected in accordance with adequate safety under the supervision of a competent person. When used, wooden or synthetic planks shall be scaffold-grade or approved by a qualified person for scaffold and stationary work platform use, and the same shall be capable of withstanding 4 times the working load.

The assembly and disassembly of scaffolds and stationary work platforms shall be done using a safety harness and lifeline as required. All temporary lighting shall be so installed so as not to make any contact with the metal frames of the scaffold. Also the scaffolding shall be double earthed. Prior to carrying out any lift installation work, fencing and warning notices should be provided at all landings indicating that there are men at work.

14.7 System Building Sites

If the building programme allows insufficient time for lift erection in conventional fashion after the well is completely built special procedures are needed. This applies particularly to industrial and multi-storeyed buildings. The building contractor should provide a suitable portable cover to the completed portion of the lift well in order to protect the lift erectors working below against the weather and falling objects.

When the top of the well has been reached it is normal to cap it immediately with a precast load bearing floor slab on to which is lowered the pre-assembled machine room equipment. It then remains for the building contractor to complete and weatherproof the machine room as swiftly as possible. On all such projects the close cooperation between the building contractor and the lift manufacturer is essential.

14.8 Connecting to Power Supply

The lift manufacturer should give prior intimation to the building contractor of the date the power supply to the lift is required, so that suitable arrangements for connection can be made.

15 INSPECTION AND ACCEPTANCE PROCEDURE FOR LIFTS

15.1 Reference

This suggested procedure for inspection of lifts is based on good practice [8-5A(2)], [8-5A(10)] and [8-5A(13)] for the traction lift.

15.2 Purpose

To ensure safe operation of new lifts on their completion and before being placed in service, they need to be subjected to acceptance inspection and tests in the field to determine that installation shall conform to the requirements of applicable standards. An inspection and test shall also be carried out on an existing installation after a major alteration.

15.3 General Requirements

These requirements shall be as follows:

- a) *Personal safety*
 - 1) Use of relevant personal protective equipment is mandatory by the inspector and his support staff at the time of inspection.
 - 2) Should stop work and arrange for correction, if unsafe conditions are noticed at the installation.
- b) *Safety precautions during inspection*
 - 1) Inspectors should have a proper working knowledge of the lifts.
 - 2) They should always ensure that the car is in his control while working on car roof and pit
 - 3) They should at all times be alert for moving objects, and when on top of an lift car for moving counter weight, hoist-way projection such as beams, adjacent moving cars, cams and other equipment attached thereto or mounted in the hoist-way.
 - 4) The overhead clearance should always be noted as number of fatal accidents occurs due to cars running into limited overhead spaces while inspections are made from top of the lift cars.
 - 5) Inspector should never enter in lift pits containing water.
 - 6) When working in the lift pit the inspector should always note the position of car.
 - 7) Keeps clear distance from descending counterweight in the hoist-way of the lift being inspected and those in adjoining hoist-way.

15.4 Description of Installation

The following provides a template of typical description of installation:

<p>Site Name with details <input style="width: 100%;" type="text"/></p> <p>Length of travel (mm) <input style="width: 100%;" type="text"/></p> <p>Number of floors served</p> <p>Total: <input style="width: 50%;" type="text"/> *</p> <p>Front: <input style="width: 50%;" type="text"/> *</p> <p>Rear: <input style="width: 50%;" type="text"/> *</p> <p>Car door: Glass / SS Landing door: Glass / SS</p> <p>Rated load <input style="width: 30%;" type="text"/> <input style="width: 30%;" type="text"/></p> <p>Rated speed <input style="width: 50%;" type="text"/> m/s *</p> <p>Lift type : Passenger / Goods Machine Room / Machine Room Less Location of Machine Room (For MR Lifts) Give a tick mark in the appropriate box</p> <p>Above well <input style="width: 50%;" type="checkbox"/></p> <p>Below well <input style="width: 50%;" type="checkbox"/></p> <p>At side <input style="width: 50%;" type="checkbox"/></p> <p>Roping ratio: _____</p>	<p>Vendor <input style="width: 100%;" type="text"/></p> <p>Job No: <input style="width: 100%;" type="text"/></p> <hr/> <p>Purchaser's identification number <input style="width: 100%;" type="text"/></p> <p>Power supply</p> <p>Permanent <input style="width: 50%;" type="checkbox"/></p> <p>Temporary <input style="width: 50%;" type="checkbox"/></p> <p>Voltage <input style="width: 50%;" type="text"/> *</p> <p>Phase <input style="width: 50%;" type="text"/> *</p> <p>Frequency <input style="width: 50%;" type="text"/> *</p> <p>Wire(3 or 4) <input style="width: 50%;" type="text"/> *</p> <p>MCCB rating <input style="width: 50%;" type="text"/> *</p> <p>ELCB rating <input style="width: 50%;" type="text"/> *</p> <p>Are the above entries acceptable</p> <p>Yes <input style="width: 50%;" type="checkbox"/> No <input style="width: 50%;" type="checkbox"/></p>
---	---

15.5 Visual and Functional Checks

A typical checklist of visual and functional checks involved in the installation of lifts is given in Annex A.

16 MAINTENANCE OF LIFTS

16.1 Following sections specify the elements necessary for the preparation of the instructions for the maintenance operations of lifts. The requirements are applicable for all new installed passenger lifts, goods — passenger lifts, special goods lifts such as vehicle lifts, service lifts.

NOTES

1 Existing installed lifts are not covered.

2 Instructions for installation and dismantling of lifts are not covered.

16.2 Maintenance of the lift essentially covers all necessary operations to ensure safe and intended functioning of the installation and its components after completion of the installation and throughout its life cycle. Maintenance includes:

- a) lubrication, cleaning, etc;

NOTE — The following cleaning operations cannot be considered as maintenance:

- 1) Cleaning of the external parts of the well, and
- 2) Cleaning of the inside of the car.

- b) checks;

- c) passenger rescue operations;
- d) the operations of setting and adjustment; and
- e) repair or changing of components which may occur due to wear and tear and do not affect the characteristics of the installation.

The following are not considered as maintenance operations:

- 1) Changing of major component such as the machine, even if the characteristics of the new component are the same as the original;
- 2) Replacement of installation;
- 3) Modernization of the installation including changing of any characteristics of the installation (such as load, speed, etc); and
- 4) Rescue operation carried out by fire brigade.

16.3 Elaboration of Maintenance Instructions

16.3.1 General

The installation shall be maintained in good working order in accordance with the manufacturer's instructions. To this effect, regular maintenance of the installation shall be carried out to ensure, in particular, the safety of the installation. The safety of an installation shall take into account the ability to be maintained without causing injury or damage to health.

Regular maintenance of the installation shall be carried out to ensure the reliability of the installation. The access and the associated environment shall be maintained in good working order in accordance with the installer's instructions.

The instructions for maintenance of an installation shall be provided by the installer after completion of the installation as a result of a risk assessment. The instructions for maintenance of the safety components of lifts shall be provided by the manufacturer to the installer. The instructions for maintenance which shall be based on a detailed risk assessment of an installation shall be provided by the manufacturer.

In order that the aim of the maintenance instructions can be achieved, they shall be formulated so that they can be clearly and easily understood by competent maintenance person.

The competent maintenance person within the maintenance organization shall be continuously updated.

NOTE — The owner of the installation should be informed that the qualification of the maintenance organization is in conformity with the regulation applicable in the state in which the installation operates.

The manufacturer shall provide maintenance instructions intended for the owner of the installation

including the information intended for the maintenance organization.

16.3.2 Elements to be Taken into Account for Maintenance Instructions

When preparing the content of the maintenance instructions the following elements shall be taken into account:

- a) The specifications and the intended use of the installation (type of installation, performance, type of goods to be transported, type of users, etc).
- b) The environment in which the installation and its components are installed (weather conditions, vandalism, etc).
- c) Any restriction of use.
- d) The result of risk assessment for every working area and for every task undertaken.
- e) The specific maintenance instructions provided by the manufacturer of safety components.
- f) In case of components other than safety components, where maintenance is necessary, the maintenance instructions provided by the manufacturer of these components.

16.3.3 Information to be Included in the Maintenance Instructions

16.3.3.1 General

The maintenance instructions shall contain information relating to the tasks of the owner and respectively the maintenance organization.

16.3.3.2 Information to the owner of the installation

The information relating to the tasks of the owner of the installation shall include that given in 16.3.3.2.1 to 16.3.3.2.16.

16.3.3.2.1 The need for the owner to keep the installation in a safe operating condition. To fulfil this owner shall use a maintenance organization complying with the requirements of this Section.

NOTE — It is recommended to inform the owner of the installation about the need to use a maintenance organization with adequate and proper insurance cover provided by an insurance company.

16.3.3.2.2 The need for the owner to take care of any state/local regulations and other requirements, where relevant, and their implications on maintenance.

16.3.3.2.3 The need for planned maintenance to be carried out by a maintenance organization, at the latest when the installation is put into service or if the installation is to remain unused for a long period of time, before being put into service first time thereafter.

16.3.3.2.4 The importance for the owner of the installation to have the same maintenance organization in the case of several installations having common well/spaces and/or machine room.

16.3.3.2.5 The need for the owner of a passenger/goods-passenger lift to keep the two-way means of communication efficient and linked to a 24 h rescue service for the whole of the time that the installation can be used.

16.3.3.2.6 The need for the owner to remove the passenger/goods-passenger lift from service when the two-way means of communication is out of order.

16.3.3.2.7 The need for the owner to put the installation out of service in case of dangerous situations.

16.3.3.2.8 The need for the owner of the installation to inform the maintenance organization,

- a) immediately about any perceived abnormal operation of the installation or abnormal change in its direct environment;
- b) immediately after putting the installation out of service in the case of a dangerous situation;
- c) after any rescue intervention by their authorized and instructed person(s);
- d) before any modification related to the installation and/or its environment or use;
- e) before any authorized third party inspection or works other than maintenance works are carried out on the installation;
- f) before taking the installation out of service for a prolonged period of time; and
- g) before putting the installation back into service after a prolonged period of non-operating time.

NOTE — The owner of the installation should obtain from the company carrying out the relevant modification the maintenance instructions for the maintenance organization.

16.3.3.2.9 The need for the owner of the installation to take into consideration the consequences of the risk assessment carried out by the maintenance organization.

16.3.3.2.10 The need for the owner of the installation to make sure that the risk assessment for maintenance is carried out,

- a) if the maintenance organization is replaced;
- b) if the use of the building and/or the installation changes;
- c) after a major modification of the installation or of the building; and
- d) if it is the case, after an accident involving the installation.

16.3.3.2.11 The need for the building owner to ensure, through a risk assessment, that,

- a) their premises are safe and free from risk to health as far as is practicable. This includes access to the premises and installation equipment, and articles or substances used according to the regulation for the use of work equipment at the workplace;
- b) the persons using the premises are informed about any remaining risks; and
- c) any action to be done as a consequence of his risk assessment is carried out.

Regarding the access ways to areas reserved to maintenance persons, the need for the owner of the installation to inform the maintenance organization, in particular about,

- 1) the access ways to be used and fire evacuating procedures from the building;
- 2) the place where the keys of the reserved areas can be found;
- 3) if necessary, the persons who shall accompany the maintenance persons to the installation; and
- 4) if necessary, personal protective equipment to be used in the access ways, and, possibly, where this equipment can be found.

The information shall be made available also on site to the maintenance organization.

16.3.3.2.12 The need for the owner of the installation to ensure that the name and the telephone number of the maintenance organization are always available to the user of the installation, permanently affixed and clearly visible.

16.3.3.2.13 The need for the owner of the installation to ensure that the keys of machine and pulley room doors (trap doors) and of inspection and emergency doors (trap doors) are permanently available in the building and are used only by persons authorized to gain access.

16.3.3.2.14 The need for the owner of the installation to provide, in all circumstances, safe access to the building and to the installation for the maintenance organization involved in the rescue of persons.

16.3.3.2.15 The need for the owner of the installation to keep the access to working areas and working rooms safe and free for the maintenance persons and to inform the maintenance organization about any hazard or change in the workplace and/or the access ways (lighting, obstructions, ground conditions, etc).

16.3.3.2.16 In addition to those examinations and tests which the owner of the installation entrusts to the

maintenance organization, the need for the owner to carry out periodically, in their own interests, the following:

A full ascent and descent travel to assess any changes in the quality of the ride or damage to the equipment. Typical items to be checked to ensure that they are in place, undamaged and functioning correctly are,

- a) landing doors and bottom door tracks;
- b) stopping accuracy;
- c) indicators that are not located in a reserved area;
- d) landing push controls;
- e) car push controls;
- f) door open controls;
- g) two-way means of communication in the car which provides permanent contact with a rescue service;
- h) normal car lighting;
- j) door reversal device; and
- k) safety signs/pictograms.

For goods only and service lifts the checks to be carried out are the same, when relevant.

16.3.3.3 Information for the maintenance organization

The information relating to the tasks of the maintenance organization shall include the following:

- a) The need to carry out the work of maintenance in conformity with the maintenance instructions and based on systematic maintenance checks. After these checks, the maintenance organization shall decide in conformity with the maintenance instructions what is required to be done.

A list of typical examples of maintenance checks to maintain the installation is shown in Annex B.

NOTE — Due to the fact that the components can be different in design and operation, it is therefore not possible to give specific guidelines.

- b) The need to update the original maintenance instructions if the installation changes its intended use and/or the environmental conditions existing on the completion of the installation.

NOTE — The maintenance organization should be provided by the owner of the installation with the relevant maintenance instructions where modifications are carried out on the installation.

- c) The need for the maintenance organization to ensure that a risk assessment for any working area and for any maintenance operation has been carried out taking into account the installer's/manufacturer's maintenance

instructions and all information supplied by the owner of the installation.

- d) The need for the maintenance organization to inform the owner of the installation about any work to be carried out as a consequence of a risk assessment especially for the access and/or the environment related to the building/installation.
- e) The need to carry out a maintenance plan so that preventive maintenance is suitable for the installation and maintenance time is as short as reasonably practicable, without reducing the safety of persons, in order to minimize the non-operational time of the installation.
- f) The need to adapt the plan for maintenance so as to take account of any predictable failures, for example, those due to misuse, mishandling, deterioration, etc.
- g) The need to carry out maintenance operations by competent maintenance persons and provided with the necessary tools and equipment.
- h) The need to maintain the competency of maintenance persons.
- j) In determining the frequency of maintenance interventions, the following non-exhaustive list should be considered:
 - 1) Number of trips per year, operating time and any non-operating periods of time;
 - 2) Age and condition of the installation;
 - 3) Location and type of building in which the installation is installed, as well as the needs of the users and/or the kind of goods transported;
 - 4) Local environment where the installation is situated, as well as external environmental elements, for example, weather conditions (rain, heat, cold, etc) or vandalism.
- k) The need to provide a 24 h, all year round call-out service for rescue of persons.
- m) The need to keep records of the result of each intervention due to a failure of the installation. These records shall include the type of failures in order to detect any repetition. They shall be available to the owner of the installation on request.
- n) The need to put out of service the installation, if the maintenance organization is aware of a dangerous situation, detected during the maintenance, which cannot be eliminated immediately, and to inform the owner of the installation of the need to keep it out of service until repaired.

- p) The need to be organized to provide the necessary spare parts for any repair.
- q) The possible need for attendance of a competent maintenance person(s), given reasonable notice, for any inspection carried out by an authorized third party or for building maintenance works to be carried out in the areas reserved for the maintenance organization .
- r) The need to inform in due time the owner of the installation about necessary progressive upgrading of the installation.
- s) The need to organize rescue operations, even with sub-contractor(s), and to make provision for circumstances such as fire, panic, etc.

16.4 Risk Assessment

16.4.1 General

Before an installation is placed on the market, it is necessary that the installer/manufacturer carry out a risk assessment. Every risk shall be limited as much as reasonably possible by means of safety measures and suitable instructions. The instructions can never replace a safety measure which can be provided to reduce the risk.

It is necessary to determine the different intervention procedures of the maintenance operations and to determine the appropriate safety measures for each of these procedures.

The use of diagnostic systems (for example, remote monitoring system) may support fault finding, improve the maintainability of the installation and reduce the exposure of maintenance persons to hazards.

Safety in maintenance operations of the installation is ensured by adopting safety measures and providing instructions. Safety measures on the installation and in the building shall be provided by the installer and by the owner of the installation, respectively.

For any working area, it is necessary to identify the list of the specific hazards related to health and safety and to carry out a risk assessment for any maintenance operation, including access to the working area.

For this purpose, the following should be taken into account:

- a) Presence of one or more maintenance persons in a working area;
- b) Foreseeable actions of persons other than maintenance persons (for example, person switching on or off power circuits and dependent circuits or lighting circuits or trying to use the installation during maintenance operations, etc); and

- c) Possible states of the installation (normal or abnormal due to a foreseeable failure of its component parts, external disturbances, disturbance of its power supply, etc).

Annex C gives a list of examples of elements to be taken into account in any risk assessment for maintenance operations. However, several methods are available for the systematic assessment of risk.

16.4.2 Information for the Maintenance Organization

For safe maintenance and to provide relevant instructions, it is necessary, first of all, to identify the maintenance operations. In particular, maintenance operations are,

- a) those operations considered necessary for a correct and safe functioning of the installation and its components after the completion of the installation;
- b) those operations considered necessary during the 'life' of some components, determining, as far as possible, the time or condition after which the functioning or the integrity of the component is no longer ensured even if correctly maintained.

In carrying out specific maintenance operations, if it is necessary to neutralize some safety functions (for example, an electric safety device), the hazard identification shall be taken into account for such a situation.

It is necessary to inform and warn the maintenance persons about,

- 1) residual risks, that is, those for which risk reduction by design and safeguarding techniques are not - or not totally - effective; and
- 2) risks that arise from the necessary removal of certain guards to carry out specific maintenance operations.

The maintenance instructions and warnings shall prescribe the procedures and operating modes intended to overcome these risks and, if it is necessary, to specify personal protective equipment, instruments, tools and provisions to be used.

16.5 Information to the Owner for Lift Rescue Operations

The information to the owner shall be inclusive of that given in 16.5.1 to 16.5.5.

16.5.1 The need for person(s) authorized by the owner of the installation to rescue trapped passengers to be trained by the maintenance organization.

16.5.2 The need to ensure that the training is appropriate to the specific installation and updated.

16.5.3 The need to ensure his authorized person(s) rescue people only through landing doors.

16.5.4 The need to ensure that the maintenance organization is called when the owner's authorized person(s) are not able to move the car through the use of the manual and/or electric emergency devices.

16.5.5 The need to inform their authorized person(s) about any conditions for which only the maintenance organization shall carry out a rescue operation.

16.6 Markings, Signs, Pictograms and Written Warnings

If the risk assessment of the maintenance organization indicates that additional specific warnings are required for the purpose of maintenance, these shall be affixed directly on the installation/component or, when this is not possible, in the close vicinity.

Markings, signs, pictograms and written warnings shall be readily understandable and unambiguous. Readily understandable signs and pictograms shall be used in preference to written warnings.

Signs or written warnings carrying only 'DANGER' shall not be used.

Information affixed directly on the installation/component shall be permanent and legible.

Any markings, signs, pictograms and written warnings affixed on the installation shall be renewed if they become illegible.

16.7 Format of the Maintenance Instruction Handbook

The maintenance instruction handbook for any installation shall contain at the front at least the following:

- a) Type of installation, with its serial number, to which the instructions apply;
- b) Title of the handbook;
- c) Date of issue;
- d) Name and address of the installer/manufacturer; and
- e) Name of the publisher, when different from the installer/manufacturer.

In the handbook,

- 1) all units used shall be SI units;
- 2) all pages shall be numbered; and
- 3) all references to other documents shall be in full.

Warnings shall state the hazard, the related risks and the appropriate safety measure.

Type and size of print shall ensure the best possible legibility. Safety warnings and/or precautions shall be emphasized through the use of colours or symbols and/or large print. Signs shall comply with the accepted standard [8-5A(14)].

Documents giving instructions for maintenance shall be produced in durable form (that is, they shall be able to survive frequent handling) or triplicate copies shall be provided.

16.8 Documents to be Kept at the Site of Installation of Lifts

The following documents shall be maintained at the job site near the controller such that they are easily available:

- a) Wiring diagram,
- b) Lift license copy,
- c) Log card, and
- d) General arrangement drawing.

ANNEX A
(Clause 15.5)

**TYPICAL CHECKLIST OF VISUAL AND FUNCTIONAL CHECKS INVOLVED IN THE
INSTALLATION OF LIFTS**

A-1 MACHINE ROOM

Sl No.	Requirement	Result	Remarks
i)	There shall be easy access from the top landing to the machine room	Accessible / Not accessible	
ii)	Steps along with handrail for the access to machine room to be provided	Provided / Not provided	
iii)	Locking arrangement shall be provided and machine room shall be kept locked	Provided / Not provided	
iv)	The machine room shall be used for the purpose of lift machinery only	Yes / No	
v)	Machine room should be free from water entry	Yes / No	
vi)	Rope hitches on the machine room are fixed as required and locked with nuts and split pins	Yes / No	
vii)	The hoisting beams or hooks provided as per the required load and marked	Provided / Not provided	
viii)	Trap door at the top of the lift well to lift the machine up or down from the machine room and to be located vertically below the hook provided in the machine room ceiling	Provided / Not provided	
ix)	Rescue chart to be pasted in the machine room with proper identification	Yes / No	
x)	The correct capacity main switch and protective device to be provided as per the requirement	Provided / Not provided	
xi)	Grounding conductor is provided and of correct size	Provided / Not provided	
xii)	Provision of log card pocket	Provided / Not provided	
xiii)	Guards to be provided for moving parts such as over speed governor (OSG), machine sheave, etc	Provided / Not provided	
xiv)	Three pin socket with switch and lighting arrangements	Provided / Not provided	
xv)	The machine room is painted and windows to be provided	Provided / Not provided	
xvi)	There shall be adequate ventilation	Provided / Not provided	
xvii)	Machine room shall be kept in clean condition	Clean / Unclean	
xviii)	Provision of caution notice indicating 'DANGER' on machine room door	Displayed / Not displayed	

A-2 POWER SUPPLY

Sl No.	Requirement	Result	Remarks
i)	Incoming power supply to be 415 V \pm 10 percent or as specified in the contract agreement	R-Y : _____ Y-B : _____ R-B : _____	

Sl No.	Requirement		Result	Remarks
			Ok / Not Ok	
ii)	Neutral – Earth voltage	Ideal condition within (0- 3) V	Value: _____ Ok / Not OK	
iii)	Neutral – Earth voltage	Running condition within (0- 3) V	Value: _____ Ok / Not OK	
iv)	Separate supply with MCB	Three phase supply	Provided / Not provided	
		Single phase supply (For car lighting and shaft lighting)	Provided / Not provided	
v)	Check whether the power cables are connected with lugs for termination		Connected / Not connected	
vi)	Shaft lighting to be provided		Provided / Not provided	

A-3 MACHINE AND BRAKE ASSEMBLY

Sl No.	Requirement	Result	Remarks
<i>Make: _____ Sl No.: _____ Rating: _____</i>			
i)	Is the machine fixation as per the installation manual	Yes / No	
ii)	Are the electrical connections of the machine routed and well tightened	Yes / No	
iii)	Machine earthing is done, routed and properly tightened	Yes / No	
iv)	Are the machine isolation pads installed correctly (if applicable)	Yes / No	
v)	Are the rope openings below the machine closed adequately as required	Yes / No	
vi)	If applicable, is the machine lubricated as required	Yes / No	
vii)	The height of the machine room shall not be less than 2 100 mm at working areas	Yes / No	
viii)	The clear height for the movement shall not be less than 1 800 mm	Yes / No	
ix)	The width of the clear space around the machine from any two sides shall not be less than 500 mm	Yes / No	
x)	Clear vertical distance of at least 300 mm is available above rotating equipment	Yes / No	
xi)	Are all the components of the brake installed, nuts tightened and locked	Yes / No	
xii)	Is the routing of the machine brake cables free from any moving parts	Yes / No	
xiii)	Is the machine brake and switches properly adjusted with correct clearance	Yes / No	
xiv)	Is the brake assembly clean, no debris and oil on disk or drum	Yes / No	
xv)	Is the manual brake release device is available and easily accessible	Yes / No	

A-4 CONTROLLER

Sl No.	Requirement	Result	Remarks
<i>Type: Sl No.: Wiring drawing No:</i>			
i)	Is the controller fixed as per the GAD (General Arrangement Drawing)	Yes / No	
ii)	Is the controller identified with the correct contract number	Yes / No	
iii)	The controller should have an easy access to open and close with lock	Yes / No	
iv)	The required warning stickers to be pasted	Provided/Not provided	
v)	All extra cables to be neatly arranged	Yes / No	
vi)	Are the battery terminals covered	Yes / No	
vii)	The field and controller wiring to be properly routed	Yes / No	

A-5 OVER SPEED GOVERNOR

Sl No.	Requirement	Result	Remarks
<i>Make: Model: Sl No: Tripping speed:</i>			
i)	Is the correct over speed governor provided and installed as per layout	Yes / No	
ii)	The sticker/painted indication represents the down direction of rotation which will facilitate the safety gear actuation	Yes / No	
iii)	Check whether the OSG is calibrated and sealed	Yes / No	
iv)	The governor is aligned and the rope passes through the holes without any obstruction	Yes / No	
v)	The governor rope runs free does not contact any with any object in the hoist-way	Yes / No	
vi)	The governor tripping mechanism is free and clean	Yes / No	
vii)	The electrical switch is provided and operates in both the directions	Yes / No	
viii)	All fixation bolts are provided and adequately tightened	Yes / No	

A-6 GENERAL INSPECTION ON CAR ROOF

Sl No.	Requirement	Result	Remarks
<i>Instructions before entering to the car top:</i>			
a) Allow the lift to move in down direction from the top terminal landing with no load.			
b) Stop the lift from the controller by changing to maintenance mode, such that easy access to enter the car top from the top terminal landing.			
c) Switch on the shaft lighting.			
d) Use the door open key to open the top terminal landing door.			
e) Switch on the car top stop switch from the landing to enable the 'STOP' mode.			
f) And then enter into the car top and switch on the light point there.			
g) Switch to maintenance mode from the car top and release the stop switch to move the lift in maintenance mode.			

SI No.	Requirement	Result	Remarks
i)	Barricade on car roof to be provided	Provided /Not provided	
ii)	Adequate lighting with proper protection is provided on the car roof	Provided /Not provided	
iii)	Wires and trunking are properly routed and does not hinder with any maintenance related equipment	Yes / No	
iv)	The car fan is properly fixed with isolation	Yes / No	
v)	Three pin plug socket with switch is available and is in working condition	Yes / No	
vi)	The emergency stop switch that should be easily accessible from outside the lift is provided of manually opened and closed type	Yes / No	
vii)	Check whether the top car clearance meets the requirement. Value required:_____	Value measured:_____ Ok / Not Ok	
viii)	Overhead dimension in W×H×D Value required:_____	Value measured:_____ Ok / Not Ok	
ix)	If overhead height is less, then the indication to be provided with ZEBRA PAINTING in the overhead	Provided / Not provided	
x)	Floor levelling switches are fixed as per requirement	Yes / No	
xi)	Rope hitches on car roof are fixed as required and locked with nuts and split pins	Yes / No	
xii)	Car sheave if available is adequately guarded from accidental contact	Yes / No	
xiii)	The junction box is fixed securely and all wires are adequately protected	Yes / No	
xiv)	The car shoe liners / rollers are fixed as per requirement and adjusted properly	Yes / No	
xv)	Oil tank are provided and fixed with proper oil levels	Yes / No	
xvi)	Engagement of the car door coupler with the landing door at every landing	Ok / Not Ok	
xvii)	Engagement of shaft limit switches	Ok / Not Ok	
xviii)	The governor rope and linkage is correctly connected to the car	Yes / No	
xix)	The guide rail clips are fixed as per requirements and in the correct directions	Yes / No	
xx)	The safety gear assembly and connecting rod should be free from external disturbances	Yes / No	
xxi)	The safety switches have been verified for correct operation during travel	Yes / No	
xxii)	The safety gear linkages is checked for operation and actuation and actuation of switches	Yes / No	
xxiii)	Clearance between the car door coupler and the landing sill to be as per the manufacturer design at every landing	Ok / Not Ok	
xxiv)	Clearance between the landing rollers with the car sill to be as per the manufacturer design at every landing	Ok / Not Ok	

A-7 PIT INSPECTION

Sl No.	Requirement	Result	Remarks
<i>Instructions before entering to the pit:</i>			
a) Allow a person in the car top and ask him to move the lift to the top most landing.			
b) Open the bottom terminal landing door with door open key.			
c) Switch on the pit stop switch from outside the pit.			
d) Enter in to the pit.			
i)	It should be clean and dry	Yes / No	
ii)	Pit ladder to be provided if the pit depth exceeds 1 500 mm as measured below the bottom most landing sill	Provided /Not provided	
iii)	Oil trays are available at the bottom of each guide rail	Provided /Not provided	
iv)	Two pit stop switches to be provided and one should be easily accessible from the bottom terminal landing	Provided /Not provided	
v)	Pit stop switches to be verified with the electrical circuit such that lift should not move further after the activation of pit stop switches	Ok /Not Ok	
vi)	Counterweight screen should be provided and fixed	Provided / Not provided	
vii)	Buffers provided for car and counterweight are correctly fixed and aligned and the electrical switch to be verified, if provided	Ok / Not Ok	
viii)	The governor tension pulley is fixed at the correct height from the pit floor as per the manufacturer recommendation	Ok / Not Ok	
ix)	The electrical switch for the tension pulley is verified, if provided	Ok / Not Ok	
x)	Check whether the bottom car clearance meets the requirement Value required:_____	Value measured:_____	
		Ok / Not Ok	
xi)	Check for the provision of car bottom light and its function	Ok / Not ok	
xii)	Is the travelling cable below car secured and correctly fixed and the excess cable is not secured below car	Ok / Not Ok	
xiii)	The travelling cable is adjusted and clear of the pit floor with the car at the lowest position	Ok / Not Ok	
xiv)	The bottom guide shoes or rollers are fixed as per requirement and adjusted for smooth travel	Ok / Not Ok	
xv)	The car safety gear is properly adjusted as per the installation manual	Ok / Not Ok	
xvi)	The compensation chain fixing arrangement is fixed as per requirement	Ok / Not Ok	

A-8 EARTHING

Sl No.	Requirement	Result	Remarks
i)	Separate earth bar to be provided in the machine room	Provided /Not provided	
ii)	Earthing to be done for all controllers and the machine	Yes / No	

SI No.	Requirement	Result	Remarks
iii)	Earthing to be done for the shaft equipment and car top components	Yes / No	
iv)	Earthing from controller to car top components to be linked through the travelling cable	Yes / No	
v)	Routing of the earth from the controller to the main earth bar	Ok / Not Ok	
vi)	Connection of the lift earth bar to main earth bar	Ok / Not Ok	

A-9 INSPECTION FROM THE LIFT CAR

SI No.	Requirement	Result	Remarks
<i>Instructions:</i>			
a) No one should be present in the pit as well as in the car top.			
b) Make sure the lift to run in normal mode.			
c) Enter the lift car from any of the landing.			
i)	Car inside width Value required: _____	Value at site: _____ Ok / Not Ok	
ii)	Car inside depth Value required: _____	Value at site: _____ Ok / Not Ok	
iii)	Height below false ceiling. Value required: _____	Value at site: _____ Ok / Not Ok	
iv)	Door opening width Value required: _____	Value at site: _____ Ok / Not Ok	
v)	Door opening height Value required: _____	Value at site: _____ Ok / Not Ok	
vi)	Car capacity to be displayed inside the lift car	Yes / No	
vii)	Safety warning plate to be displayed (<i>see</i> Note)	Yes / No	
viii)	Functioning of car display	Functioning / Not functioning	
ix)	Functioning of floor announcement, ARD announcement, etc (if applicable)	Functioning / Not functioning	
x)	DO button and DC button functional check: <i>For power operated door:</i> 1) Press the DO button at level — Door should open 2) Press the DO button during running — Door should not open 3) While closing press the DO button at level — Door should open 4) DC button at level when the door is in open condition — Door should close	Functioning / Not functioning	

Sl No.	Requirement	Result	Remarks
xi)	<i>For manual operated door:</i> 1) Lift should not move if any of the door car/landing in open condition 2) If door is opened during run, lift should stop and should not move further	Functioning / Not functioning	
xii)	Car alarm should function even though there is no power supply to the lift	Functioning / Not functioning	
xiii)	Functioning of intercom (<i>see Note</i>)	Functioning / Not functioning	
xiv)	Functioning of car call buttons and landing call buttons (<i>see Note</i>)	Ok / Not ok	
xv)	Provision of fan and its operations	Provided / Not provided	
xvi)	Provision and working of cabin lights and shaft lights	Provided / Not provided	
xvii)	Provision of emergency light and its functions	Provided / Not provided	
xviii)	Doors are verified for smooth opening and closing at each level	Ok / Not ok	
xix)	Riding comfort — No rail knocks and vibrations are heard while travelling several times in either directions	Ok / Not ok	
xx)	Lift should not move for any safety failure	Ok / Not ok	
xxi)	Provision of grab bars inside the lift car (<i>see Note</i>)	Provided / Not provided	
xxii)	Provision of buffer rail (applicable only for service lifts) at the rear panel of the lift car	Provided / Not provided	

NOTE — Lifts open to public use shall also be inspected for requirements as per 13 of Part 3 'Development Control Rules and General Building Requirements' of the Code, including those relating to lift closing time, finishes of interior surfaces, etc.

A-10 INSPECTION FROM THE FLOOR LANDINGS

Sl No.	Requirement	Result	Remarks
i)	Provision and functioning of landing door de-locking at every landing	Functioning / Not functioning	
ii)	Condition of landing door at every floor	Ok / Not ok	
iii)	Functioning of landing display at every floor	Functioning / Not functioning	
iv)	Functioning of landing call button	Functioning / Not functioning	
v)	Functioning of duplex/group operation at every landing (if applicable)	Functioning / Not functioning	

A-11 RESCUE OPERATIONS

SI No.	Requirement	Result	Remarks
i)	Is the automatic rescue device (ARD) installed and operating as per the instructions	Yes / No	
ii)	Does visual indicator and audible alarm function during operation	Yes / No	
iii)	Is the floor level acceptable during the automatic rescue operation	Yes / No	
iv)	Whether the lift moves when the brake is opened depending upon the inertia	Yes / No	
v)	Provision of emergency electrical rescue device and its functioning (if applicable)	Functioning / Not functioning	

A-12 FIRE OPERATION

SI No.	Requirement	Result	Remarks
i)	<i>Phase I</i> a) When the fireman switch is activated, all the landing calls to be inoperative and the car shall report to the evacuation floor and the lift doors to be in opened condition b) If the lift is moving away from the evacuation floor, then it shall reverse its direction at the nearest floor landing without opening its door, and return back to the evacuation floor and remains there itself with the doors open	Functioning / Not functioning	
ii)	<i>Phase II (if applicable)</i> a) It will be started after the completion of Phase I along with the fireman switch in ON position b) In Phase II, lift should not respond to landing call and when the car call button is pressed, the door should start closing. If the button is released before the full closure of doors, then the doors should open automatically c) After the full close of door, the lift should move on to the floor of registered car call d) The doors should only open if the open button is pressed after reaching the level. If the open button is released before the full opening of doors, then the doors should reclose automatically	Functioning / Not functioning	

A-13 SAFETY DEVICES

SI No.	Requirement	Result	Remarks
<i>Instructions:</i> a) The lift is in ideal condition and the following safety devices get activated, then it should not move further. b) If the lift is in running condition and the following safety devices get activated, then the lift shall stop and should not move further.			
i)	OSG – Over speed governor	Functioning / Not functioning	
ii)	Car door contact	Functioning / Not functioning	
iii)	Landing door contact	Functioning / Not functioning	

Sl No.	Requirement	Result	Remarks
iv)	Car top stop switches	Functioning / Not functioning	
v)	Pit stop switches	Functioning / Not functioning	
vi)	Functioning of screen sensors and door safety edge: 1) Door should reopen, if we cut the screen. 2) Door should reopen, if it hit any object.	Functioning / Not functioning	
vii)	Check whether the car and counter buffers are installed as per the requirement	Yes / No	
viii)	Functioning of limit switches so that lift should not travel beyond the limit	Functioning / Not functioning	
ix)	Brake on its own shall be capable of stopping the machine when the car is travelling downward at rated speed and with the rated load plus 25 percent	Ok / Not Ok	
x)	<i>Safety gear test:</i> 1) Lift car safety gear to be tested in down direction with 100 percent rated load in the lift car (during maintenance it shall be tested only in inspection speed) 2) If provided, counterweight safety gear to be tested in up direction of lift car with no load Lift stopping distance depends upon the tripping speed of the governor and is to be within the range as per the Indian Standard.	Stopping distance: _____ Ok / Not Ok	

A-14 LEVELLING ACCURACY AND RUNNING CLEARANCE TEST

<i>Instructions:</i> a) The levelling accuracy shall be within ± 5 mm of the finished floor level. b) The running clearance between the lift car threshold and landing door sill should be 30 mm. <i>No. of floors:</i> _____					
Floors (Landing)	Levelling Accuracy		Running Clearance		
	UP	DN	LH	Centre	RH
1st					
2nd					
3rd					
4th					
5th					
6th					
...					
...					
RESULT Ok / Not Ok					

A-15 LOAD TEST

Sl No.	Load in Percent	Direction of Travel	Voltage	Current
			V	A
<i>Instructions:</i>				
a) With balanced load, the current value in both the up and down directions to be same.				
b) Check the current only after the lift reaches its rated speed.				
i)	No load	UP		
		DN		
ii)	Half load	UP		
		DN		
iii)	Full load	UP		
		DN		

ANNEX B

[Clause 16.3.3.3 (a)]

TYPICAL EXAMPLES OF CHECKS TO BE TAKEN INTO ACCOUNT IN MAINTENANCE INSTRUCTIONS

B-1 ELECTRIC LIFTS

Item	Checks
General	Check all components are clean and kept free from dust and corrosion
Pit area	Check for excess oil/grease at bottom of guides. Check the pit area is clean, dry and free from debris
Anti-rebound device and switch (where fitted)	Check for free movement and operation Check for equal tension of ropes Check switch where fitted Check lubrication
Buffers	Check oil level Check lubrication Check switch where fitted Check fixings
Drive motor/generator	Check bearings for wear Check lubrication Check condition of commutator
Gear box	Check gear for wear Check lubrication
Traction sheave	Check condition and grooves for wear
Brake	Check braking system Check parts for wear Check stopping accuracy

Item	Checks
Controller	Check cabinet is clean, dry and free from dust
Overspeed governor and tension pulley	Check moving parts for free movement and wear Check operation Check switch
Main rope diverter pulley(s)	Check condition and grooves for wear Check bearings for abnormal noise and/or vibrations Check guarding Check lubrication
Car/counterweight guides	Check for film of oil where required on all guide surfaces Check fixings
Car/counterweight guide shoes	Check guide shoes/rollers for wear Check fixings Check lubrication, where necessary
Electric wiring	Check insulation
Lift car	Check emergency lighting, car buttons, key switches Check fixings of panels and ceiling
Safety gear(s)/ascending car over speed protection means	Check moving parts for free movement and wear Check lubrication Check fixings Check operation Check switch
Suspension ropes/chains	Check for wear, elongation and tension Check lubrication only where intended
Rope/chains terminations	Check for deterioration and wear Check fixings
Landing entrances	Check operation of landing locks Check doors for free running Check door guiding Check door gaps Check wire rope, chain or belt when used for integrity Check emergency unlocking device Check lubrication
Car door	Check door closed contact or lock Check doors for free running Check door guiding Check door gaps Check wire rope or chain when used for integrity Check passenger door protective device Check lubrication
Floor level	Check stopping accuracy at landing
Final limit switches	Check operation
Motor run time limiter	Check operation
Electric safety devices	Check operation Check electric safety chain

Item	Checks
	Check correct fuses are fitted
Emergency alarm device	Check operation
Landing controls and indicators	Check operation
Well lighting	Check operation

B-2 HYDRAULIC LIFTS

Item	Checks
General	Check all components are clean and kept free from dust and corrosion
Pit area	Check for excess oil/grease at bottom of guides Check the pit area is clean, dry and free from debris
Buffers	Check oil level Check lubrication Check switch where fitted Check fixings
Tank unit	Check hydraulic fluid level Check tank and valve unit for leakage
Jack	Check for oil leakage
Telescopic jack	Check for synchronization
Controller	Check cabinet is clean, dry and free from dust
Overspeed governor and tension pulley	Check moving parts for free movement and wear Check operation Check switch
Main rope pulley(s)	Check condition and grooves for wear Check bearings for abnormal noise and/or vibrations Check guarding Check lubrication
Car/balancing weight/jack guides	Check for film of oil where required on all guide surfaces Check fixings
Car/balancing weight/jack guide shoes	Check guide shoes/rollers for wear Check fixings Check lubrication where necessary
Electric wiring	Check insulation
Lift car	Check emergency lighting, car buttons, key switches Check fixings of panels and ceiling
Safety gear/pawl clamping devices	Check moving parts for free movement and wear Check lubrication Check fixings Check operation Check switch
Suspension ropes/chains	Check for wear, elongation and tension Check lubrication only where intended
Ropes/chains terminations	Check for deterioration and wear Check fixings

Landing entrances	<ul style="list-style-type: none"> Check operation of landing locks Check doors for free running Check door guiding Check door gaps Check wire rope, chain or belt when used, for integrity Check emergency unlocking device Check lubrication
Car door	<ul style="list-style-type: none"> Check door closed contact or lock Check doors for free running Check door guiding Check door gaps Check wire rope or chain when used for integrity Check passenger door protective device Check lubrication
Floor level	Check stopping accuracy at landing
Final limit switch	Check operation
Motor run time limiter	Check operation
Electric safety devices	<ul style="list-style-type: none"> Check operation Check electric safety chain Check correct fuses are fitted
Emergency alarm device	Check operation
Landing controls and indicators	Check operation
Well lighting	Check operation
Anti-creep device	Check operation
Rupture valve/one way restrictor	Check operation
Pressure relief valve	Check operation
Manual lowering valve	Check operation
Hand pump	Check operation
Hose/pipe work	Check for damage and leakage

ANNEX C
(Clause 16.4.1)

EXAMPLES OF ELEMENTS TO BE TAKEN INTO ACCOUNT IN ANY RISK ASSESSMENT FOR MAINTENANCE OPERATIONS

Elements	Car	Machinery Spaces	Pulley Spaces	Area Outside the Lift	Pit	Car Roof
Unsuitable access (ladders not secure, no hand rails, unsuitable trap door, obstacle on car roof, etc)	NR	R	R	R	R	R
Unauthorized entry	NR	R	R	R	R	R
Inadequate lighting (including access)	R	R	R	R	R	R
Uneven floor surface (holes, projections)	R	R	R	R	R	R
Slippery floor surface	R	R	R	R	R	R
Strength of floor	R	R	R	R	R	R
Unsuitable dimensions (passages, maintenance spaces)	R	R	R	R	R	R
Identification of car position	R	R	NR	NR	NR	NR
Indirect contact with electricity	R	R	R	R	R	R
Switches	NR	R	R	R	R	R
Contact with moving parts (ropes, pulleys)	NR	R	R	R	R	R
Unexpected movements	R	R	R	R	R	R
Crushing by moving parts (car, counterweight)	NR	R	R	R	R	R
Voids between car and well	NR	R	R	NR	NR	R
More than one lift in same area	NR	R	R	R	R	R
Overhead beams and sheaves	NR	R	R	R	R	R
Refuge volume(s)	NR	R	R	NR	R	R
Manual handling	NR	R	R	R	R	R
More than one maintenance person working	NR	R	R	R	R	R
Absence of means of communication	R	R	R	R	R	R
Ventilation and temperature for persons	R	R	R	R	R	R
Dangerous substances	R	R	R	R	R	R
Falling objects	R	R	R	R	R	R
Entrapment	R	R	R	R	R	R
Means/controls for rescue operations	R	R	R	R	R	R
Fire	R	R	R	R	R	R

'R' = Relevant and 'NR' = Not relevant.

LIST OF STANDARDS

The following list records those standards which are acceptable as 'good practice' and 'accepted standards' in the fulfillment of the requirements of the code. The latest version of a standard shall be adopted at the time of enforcement of the code. The standards listed may be used by the Authority for conformance with the requirements of the referred clauses in the code.

In the following list, the number appearing in the first column within parentheses indicates the number of the reference in this Subsection.

<i>IS No.</i>	<i>Title</i>	<i>IS No.</i>	<i>Title</i>
(1) 14671 : 1999	Code of practice for installation and maintenance of hydraulic lifts	(5) 14665 (Part 4/ Sec 1 to 9) : 2001	Electric traction lifts: Part 4 Components, Section 1 Lift buffers, Section 2 Lift guide rails and guide shoes, Section 3 Lift carframe, car, counterweight and suspension, Section 4 Lift safety gears and governors, Section 5 Lift retiring cam, Section 6 Lift doors and locking devices and contacts, Section 7 Lift machines and brakes, Section 8 Lift wire ropes, Section 9 Controller and operating devices
(2) 14665 (Part 1) : 2000	Electric traction lifts Guidelines for outline dimensions of passenger, goods, service and hospital lifts	(6) 14665 (Part 3/ Sec 1 and 2) : 2000	Electric traction lifts: Part 3 Safety rules, Section 1 Passenger and goods lifts, Section 2 Service lifts
(Part 3/ Sec 1 and 2) : 2000	Safety rules, Section 1 Passenger and goods lifts, Section 2 Service lifts	(7) 14665 (Part 2/ Sec 1 and 2) : 2000	Electric traction lifts : Part 2 Code of practice for installation, operation and maintenance, Section 1 Passenger and goods lifts, Section 2 Service lifts
(Part 4/ Sec 1 to 9) : 2001	Components, Section 1 Lift buffers, Section 2 Lift guide rails and guide shoes, Section 3 Lift Carframe, car, counterweight and suspension, Section 4 Lift safety gears and governors, Section 5 Lift retiring cam, Section 6 Lift doors and locking devices and contacts, Section 7 Lift machines and brakes, Section 8 Lift wire ropes, Section 9 Controller and operating devices	(8) 3043 : 1987	Code of practice for earthing
(3) 12615 : 2011	Energy efficient induction motors — Three phase squirrel cage	(9) IS/IEC 60529 : 2001	Degrees of protection provided by enclosures (IP CODE)
(4) 1950 : 1962	Code of practice for sound insulation of non-industrial buildings	(10) 15785 : 2009	Code of practice for installation and maintenance of lifts without conventional machine room
		(11) 15259 : 2002	Code of practice for installation and maintenance of home lifts
		(12) 15330 : 2003	Code of practice for Installation and maintenance of lifts for handicapped persons
		(13) 14665 (Part 5) : 1999	Electric traction lifts: Part 5 Inspection manual
		(14) 9457 : 2005	Code of practice for safety colours and safety signs (<i>first revision</i>)

NATIONAL BUILDING CODE OF INDIA

PART 8 BUILDING SERVICES

Section 5 Installation of Lifts, Escalators and Moving Walks:

5B Escalators and Moving Walks

BUREAU OF INDIAN STANDARDS

CONTENTS

FOREWORD	... 3
1 SCOPE	... 5
2 TERMINOLOGY	... 5
3 GENERAL	... 6
4 DESIGN GUIDELINES FOR ESCALATORS AND MOVING WALKS	... 8
5 ARRANGEMENT AND PLANNING DIMENSIONS	... 8
6 SPACE REQUIREMENT	... 12
7 FIRE PROTECTION	... 18
8 MINIMUM TECHNICAL AND SAFETY REQUIREMENTS	... 19
9 SPECIAL TECHNICAL REQUIREMENTS	... 23
10 PERFORMANCE REQUIREMENTS FOR ESCALATORS AND MOVING WALKS	... 25
11 ESCALATOR AND MOVING WALK ENQUIRY OR INVITATION TO TENDER	... 26
12 ACCEPTANCE OF TENDER AND SUBSEQUENT PROCEDURE	... 27
13 COORDINATION OF SITE WORK	... 28
14 INSPECTION AND ACCEPTANCE PROCEDURES	... 28
15 OPERATION AND MAINTENANCE	... 31
ANNEX A TYPICAL ESCALATOR SITE CHECKLIST/INSPECTION LIST	... 36
ANNEX B TYPICAL CHECK LIST FOR FUNCTIONAL TESTS ON SAFETY SWITCHES AND DEVICES	... 40
ANNEX C TYPICAL EXAMPLES OF MAINTENANCE CHECKS TO MAINTAIN THE INSTALLATION	... 42
ANNEX D EXAMPLES OF ELEMENTS TO BE TAKEN INTO ACCOUNT IN ANY RISK ASSESSMENT FOR MAINTENANCE OPERATIONS	... 43
LIST OF STANDARDS	... 44

FOREWORD

This Code (Part 8/Subsection 5B) covers the essential requirements for planning, installation, operation, maintenance and inspection of escalators and moving walks so as to ensure safe movement of people with satisfactory performance, while using these.

This Section was first published in 1970 and was subsequently revised in 1983 and 2005. This Section covers the requirements for installation of lifts and escalators in buildings. This Section shall be read with Part 4 'Fire and Life Safety' of the Code from fire safety requirements point of view. The major changes in the first revision of 1983 were addition of outline dimensions of different types of lifts and detailed requirements of escalators in buildings. Emphasis was laid on coordination between the engineer/architect and the lift manufacturer to arrive at the number and position of lifts for attaining optimum efficiency in serving the building with safety.

The significant changes with respect to lifts incorporated in the last revision in 2005, included addition of new clauses/recommendations on building management system; addition of new clauses on fireman's lift, infrared light curtain, safety and Braille button for blind people and updation of provisions as per the revised standards on lifts on which this Section was based.

As a result of experience gained since implementation of 2005 version of the Code and feedback received as well as revision of Indian Standards on which this Section was based, a need was felt to revise this Section. In this revision, the erstwhile Section 5 on Lifts and Escalators has been divided into two subsections namely:

5A Installation of Lifts

5B Installation of Escalators and Moving Walks

This revision has, therefore, been formulated to take care of these. This Subsection (5B) addresses exclusively the provisions related to installation of escalators and moving walks, which are being increasingly provided in buildings. Compared to the previous version where brief details were covered in Section 5 with respect to escalators, this Subsection now covers comprehensive provisions on all aspects, including requirements for planning, installation, operation, maintenance and inspection of escalators, so as to ensure safe movement of people with satisfactory performance. This also now covers provisions on moving walks.

Assistance has been derived from the following publications in the formulation of this Subsection:

EN 115-1: 2008 Safety of escalators and moving walks — Part 1: Construction and installation

IBC 2015 International Building Code, International Code Council, Washington, USA

JIS A 4302 : 2006 Inspection standard of elevator, escalator and dumbwaiter

CIBSE Guide D: Transportation Systems in Buildings, 2015, The Chartered Institution of Building Services Engineers, London, U.K.

All standards, whether given herein above or cross-referred to in the main text of this Subsection, are subject to revision. The parties to agreement based on this Subsection are encouraged to investigate the possibility of applying the most recent editions of the standards.

For the purpose of deciding whether a particular requirement of this Subsection is complied with, the final value, observed or calculated, expressing the result of a test or analysis, shall be rounded off in accordance with IS 2 : 1960 'Rules for rounding off numerical values (*revised*)'. The number of significant places retained in the rounded off value should be the same as that of the specified value in this Subsection.

NATIONAL BUILDING CODE OF INDIA

PART 8 BUILDING SERVICES

Section 5 Installation of Lifts, Escalators and Moving Walks: 5B Escalators and Moving Walks

1 SCOPE

1.1 This Code (Part 8/Subsection 5B) covers the essential requirements for planning, installation, operation, maintenance and inspection of escalators and moving walks so as to ensure safe movement of people with satisfactory performance, while using these.

1.2 This Subsection gives information that should be exchanged among the architect/engineer, the consulting engineer and escalator/moving walk manufacturer from the stage of planning to installation including maintenance.

2 TERMINOLOGY

For the purpose of this Subsection, the following terms and definitions apply.

2.1 General Terms Relating to Escalators and Moving Walks

2.1.1 *Angle of Inclination* — Maximum angle to the horizontal in which the steps, the pallets or the belt move.

2.1.2 *Auxiliary Brake* — Fail safe brake, which is used to stop an escalators/moving walk under all normal conditions or under certain fault conditions only, typically situated on one side of the main drive shaft.

2.1.3 *Balustrade* — Part of the escalator/moving walk which ensures the user's safety by providing stability, protecting from moving parts and supporting the handrail.

2.1.4 *Balustrade Decking* — Transverse member of the balustrade which meets the handrail guidance profile and which forms the top cover of the balustrade.

2.1.5 *Brake Load* — Load on the step/pallet/belt for which the brake system is designed to stop the escalator/moving walk.

2.1.6 *Comb* — Pronged section at each landing that meshes with the grooves of the steps

2.1.7 *Comb Lighting* — Small flush light panels located in the skirt panels on both sides of the escalators/moving walk unit at both upper and lower landing and immediately adjacent to the comb teeth to illuminate the comb and step tread and assist passengers boarding and alighting the escalators/moving walk.

2.1.8 *Comb Plate* — Platform at each landing to which the combs are attached.

2.1.9 *Comb Plate Switch* — Switch in safety circuit that opens when excessive force is detected in vertical and/or horizontal direction on the comb or comb plate of escalators/moving walk.

2.1.10 *Comb Teeth* — Series of teeth which ride the grooves of the escalators/moving walk step tread as the step passes underneath and are designed so as to allow them to break off, if a wedging action should occur at their point of contact with step tread.

2.1.11 *Emergency Brake* — Auxiliary mechanically automatically operated brake, which will stop a fully loaded escalator, if the drive chain breaks.

2.1.12 *Emergency Stop Switch* — Separate stop button usually located in adjacent walls, columns or within the balustrade providing the facility to stop the escalator/moving walk, in the event of emergency.

2.1.13 *Inspection Door* — Means of access to equipment areas and other spaces pertaining to an escalators/moving walk installation such as machinery spaces, etc, and with access usually restricted to authorized persons.

2.1.14 *Safety Devices* — Part of a safety circuit consisting of safety switches and/or fail safe circuits.

2.1.15 *Escalator* — Power-driven, inclined, continuous moving stairway used for raising or lowering persons in which the user carrying surface (for example, steps) remains horizontal.

NOTE — Escalators are machines, and even when out of operation, shall not be considered as fixed staircases as there could be a safety concern.

2.1.16 *Exterior Panel* — Part of the exterior side of the enclosure of an escalator or moving walk.

2.1.17 *Handrail* — Power-driven moving rail for persons to grip while using the escalator or moving walk.

2.1.18 *Interior Panel* — Panel located between the skirting or lower inner decking and the handrail guidance profile or balustrade decking.

2.1.19 *Lower Inner Decking* — Profile that connects

the skirting with the interior panel when they do not meet at a common point.

2.1.20 Lower Outer Decking — Profile that connects the exterior panels with the interior panel.

2.1.21 Machinery — Escalator or moving walk machine(s) mechanisms and associated equipment.

2.1.22 Machinery Spaces — Space(s) inside or outside of the truss where the machinery as a whole or in parts is placed.

2.1.23 Maximum Capacity — Maximum flow of persons that can be achieved under operational conditions.

2.1.24 Moving Walk — Power-driven installation for the conveyance of persons in which the surface carrying the users remains parallel to its direction of motion and is uninterrupted (for example, pallets, belt).

NOTE — Moving walks are machines, and even when out of operation, shall not be considered as fixed access as there could be a safety concern.

2.1.25 Newel — End of the balustrade.

2.1.26 Nominal/Rated Speed — Speed in the direction of the moving steps, pallets or the belt stated by the manufacturer for which the escalator or moving walk has been designed, without load on the steps/pallets/belt at nominal frequency and nominal voltage.

2.1.27 Pit — Recess in the floor to receive that portion of the lower landing and the lower end of the incline section which occurs below the floor line when there is no floor under the escalator such as in a basement.

2.1.28 Rated Load — Load which the equipment is designed to move.

2.1.29 Rise (Travel) — Vertical distance between the upper and lower finished floor levels.

2.1.30 Safety Circuit — Part of the electric safety system consisting of electrical safety devices.

2.1.31 Skirting — Vertical part of the balustrade interfacing with the steps, pallets or belt.

2.1.32 Skirt Deflector — Device to minimize the risk of trapping between the step and the skirting.

2.2 Terms Related to Performance Requirements of Escalators and Moving Walks

2.2.1 Acceleration — Rate of change of velocity. It is expressed in m/s^2 .

2.2.2 Background Noise Correction (K_{1A}) — Correction term to account for the influence of background noise on the emission sound pressure level at the specified positions of the machine under test.

NOTE — The correction in the case of A-weighting is to be determined from A-weighted measured values.

2.2.3 Emission Sound Pressure Level (L_{pA}) — A-weighted sound pressure level at the specified positions, excluding the effects of background noise and contribution due to the room characteristics (reverberation) of the *in-situ* environment. It is expressed in decibel.

2.2.4 Environmental Indicator (K_{2A}) — Correction term to account for the influence of reflected sound on the emission sound pressure level due the characteristic of the test room.

2.2.5 Equivalent Sound Pressure Level (L_{pAeq}) — Average A-weighted sound pressure level.

2.2.6 Load Carrying Unit — Part of an escalator or moving walk designed to carry persons for the purpose of transportation. For example, step, pallet or belt.

2.2.7 Measured Speed — Speed of the escalator or moving walk with no load measured at the time of testing after the starting sequence has been completed.

2.2.8 Ride Quality — Sound levels and vibration of the steps/pallet, relevant to passenger perception, associated with escalator or moving walk operation.

2.2.9 Sound Pressure Level (L_p) — Ten times the logarithm to the base 10 of the ratio of the square of the sound pressure to the square of the reference sound pressure.

NOTE — The reference sound pressure level is $20 \mu Pa$ ($2 \times 10^{-5} Pa$).

2.2.10 Velocity — Rate of change of displacement. Velocity is reported as speed and direction of travel. It is given in metre per second (m/s).

2.2.11 Vibration — Variation with time of the magnitude of acceleration. It is expressed in metre per second square (m/s^2).

3 GENERAL

3.1 Conformity with Act and Rules

3.1.1 The installation of escalators and moving walks has been governed in states by different Acts and Rules, as applicable, which are intended to ensure safe installation and operation of the same.

3.1.2 The installation shall be generally carried out in conformity with relevant Act and Rules wherever they are in force.

3.1.3 It is the responsibility of the owner of the premises where the escalators and moving walks will be installed, to obtain necessary permission from the Authority before and after the erection of escalators and moving walks and for their subsequent operation.

3.1.4 A licence for public use is a safety provision issued by state authorities under applicable Act and Rules, wherever they are in force.

3.2 Conformity with *Indian Electricity Act and Rules*

All electrical work in connection with installation of escalators and moving walks shall be carried out in accordance with the provisions of *The Indian Electricity Act, 2003* as amended up-to-date along with the rules and regulations framed thereunder and shall also comply with the other provisions of Part 8 'Building Services, Section 2 Electrical and Allied Installations' of the Code.

3.3 Conformity with Indian Standards

All materials, fittings, appliances, etc, used in electrical installation shall conform to Indian Standard specifications, wherever these exist. In case of materials for which Indian Standard specifications do not exist, the materials shall be approved by the competent authority.

3.4 Conformity with Fire Regulations

The installation shall be carried out in conformity with Part 4 'Fire and Life Safety' of the Code and the state fire acts/local fire regulations, wherever they are in force.

3.5 Safety Design Considerations and Selection of Escalator and Moving Walks

The design consideration for type and selection of escalator and moving walk shall be based on following criteria:

- a) *Location* — To ensure reliability, it is important to have design specifications to suit environmental conditions.
- b) *Physical requirements* — Physical factors like the vertical and horizontal distance to be spanned shall be considered. The ability of the building infrastructure to support the heavy components is also a critical physical concern.
- c) *Type of segment and traffic patterns* — The design consideration depends on segment type. Some typical segments are transit systems like metro, airport, shopping malls, hotels, etc. Traffic patterns shall also be anticipated in escalator and moving walk design. The carrying capacity of an escalator system shall match the expected peak traffic demand.
- d) *Safety considerations* — Escalators and moving walks shall not be subjected to abuse, misuse and negligence. There are a number

of potential hazards, both from escalators and moving walks themselves and also those hazards that users may bring with them, which include loose clothing, type of footwear, carried goods and trolleys. The severity of these hazards may increase when used by vulnerable groups of people, such as the old, very young and those with impaired mobility. The proper design risk assessment and control, are all critical to ensure reliability and, above all safety.

- e) *Aesthetic preferences* — To be suitably decided between the parties concerned.

3.6 Maintenance

The considerations relating to maintenance shall be as follows:

- a) The escalator or moving walk installation should receive regular cleaning, lubrication, adjustment and adequate servicing by authorized competent persons at such intervals as the type of equipment and frequency of service demand. It is desirable and normal for the escalator or moving walk supplier to be entrusted with the servicing during the guarantee period of new equipment.
- b) In order that the escalator or moving walk installation is maintained at all times in a safe condition, a proper maintenance schedule shall be drawn up in consultation with the manufacturer and rigidly followed. The provision of a log book to record all items relating to general servicing and inspection is recommended. Any accident arising out of operation or maintenance shall be duly reported to the Authority in accordance with the rules laid down.
- c) Escalators and moving walks are required by statutory regulations to be examined at regular intervals as specified by Acts and Rules, by a competent person. The company entrusted with maintenance contract shall have valid license to maintain the escalators and moving walks. The persons assigned for maintenance work shall be appropriately qualified and experienced as required by statutory Acts and Rules.
- d) Companies and organizations responsible for the safe use of escalator and moving walks should ensure that their employees are adequately instructed and informed about the safe use of the escalator or moving walk and the hazards arising from their unsafe use and are familiar with emergency procedures.

- e) Proper barricading shall be done to ensure that the open pits of escalator shall be reached/ accessed by only the maintenance team. The maintenance service provider shall be responsible for placing of the barricades and signages before start of the maintenance work.

3.7 Energy Efficiency and Sustainability

The following technologies shall be encouraged for reducing power consumption by using energy efficient equipment and behavioural changes:

- a) As an option, escalators/moving walk should not run when there are no passengers to move. In this stop mode, only the control system and the passenger detection system are kept running. Another option is to reduce the speed to match the passenger demand, thus reducing energy consumption by the use of variable voltage variable frequency (VVVF) drives, which provide very smooth, almost imperceptible speed transitions.
- b) Energy saving LED lamps for lighting in place of conventional lamps.
- c) Improvement in total power factor of the motor drive of an escalator or moving walk at the isolator connecting equipment to the building’s electrical supply circuit.
- d) Adoption of materials and practices that are environmental friendly and sustainable shall be promoted.

4 DESIGN GUIDELINES FOR ESCALATORS AND MOVING WALKS

4.1 Escalators are desirable where the movement of people, in large numbers at a controlled rate in the minimum of space, is involved, for example, railway stations, shopping centres/malls, airports, etc. These encourage people to circulate freely and conveniently. Inclined moving walks are preferable where trolley movement is expected between levels, like department stores, airport, etc.

Typically, horizontal moving walks are used where medium to long distance travel is involved such as airports/metro stations/exhibition halls.

4.2 As the escalators and moving walks operate at a constant speed, serve only two levels and have a known maximum capacity, the traffic study is rather easy, provided the population to be handled in a given time is known. It is easy to predict the rate at which the population can be handled.

Figure 1 shows the brief idea about the steps to be followed for arriving at appropriate escalator and moving walk solution for particular application.

Based on Fig. 1, type and location of building, expected population, and the serving floor details are required to work on the preliminary traffic analysis for escalators and moving walks.

For normal peak periods, the recommended handling capacities for design purposes should be taken as indicated in Table 1. The handling capacity of escalator also depends on the angle of inclination, speed, step widths and the areas at the boarding and alighting levels.

Table 1 Expected Pedestrian Flow Rates
(Clause 4.2)

Sl No.	Duty Category	Typical Usage (Passengers/Day)	Typical Locations
(1)	(2)	(3)	(4)
i)	Light	Up to 4 000	Shops, leisure facilities, multiplexes
ii)	Medium	Up to 10 000	Department stores, shopping centres, domestic airports and railway stations
iii)	Heavy	Up to 20 000	Railway (junctions), metro stations, airports
iv)	Intensive	Over 20 000	Major railway (junctions), metro stations, international airports

4.3 The number of persons that may be theoretically carried by the escalators and moving walks in 1 h is given in Table 2 and Table 3, respectively.

Table 2 Theoretical Capacity for Escalators
(Clause 4.3)

Sl No.	Step Width m	Theoretical Capacity, in Persons/h		
		For 0.5 m/s Speed	For 0.65 m/s Speed	For 0.75 m/s Speed
(1)	(2)	(3)	(4)	(5)
i)	0.6	4 500	5 850	6 750
ii)	0.8	6 750	8 775	10 125
iii)	1.0	9 000	11 700	13 500

4.4 Though **4.3** indicates the theoretical values for escalators (*see* Table 2) and moving walks (*see* Table 3), Tables 4 and 5 indicate the practical values to be considered while calculating the required number of escalators and moving walks (based on traffic flow pattern).

5 ARRANGEMENT AND PLANNING DIMENSIONS

5.1 Escalators are typically used for short range of movement between adjacent floors. They are usually situated in an obvious circulation path making it easy for pedestrians to board them. Escalators and moving walks should only be accessed from adjacent

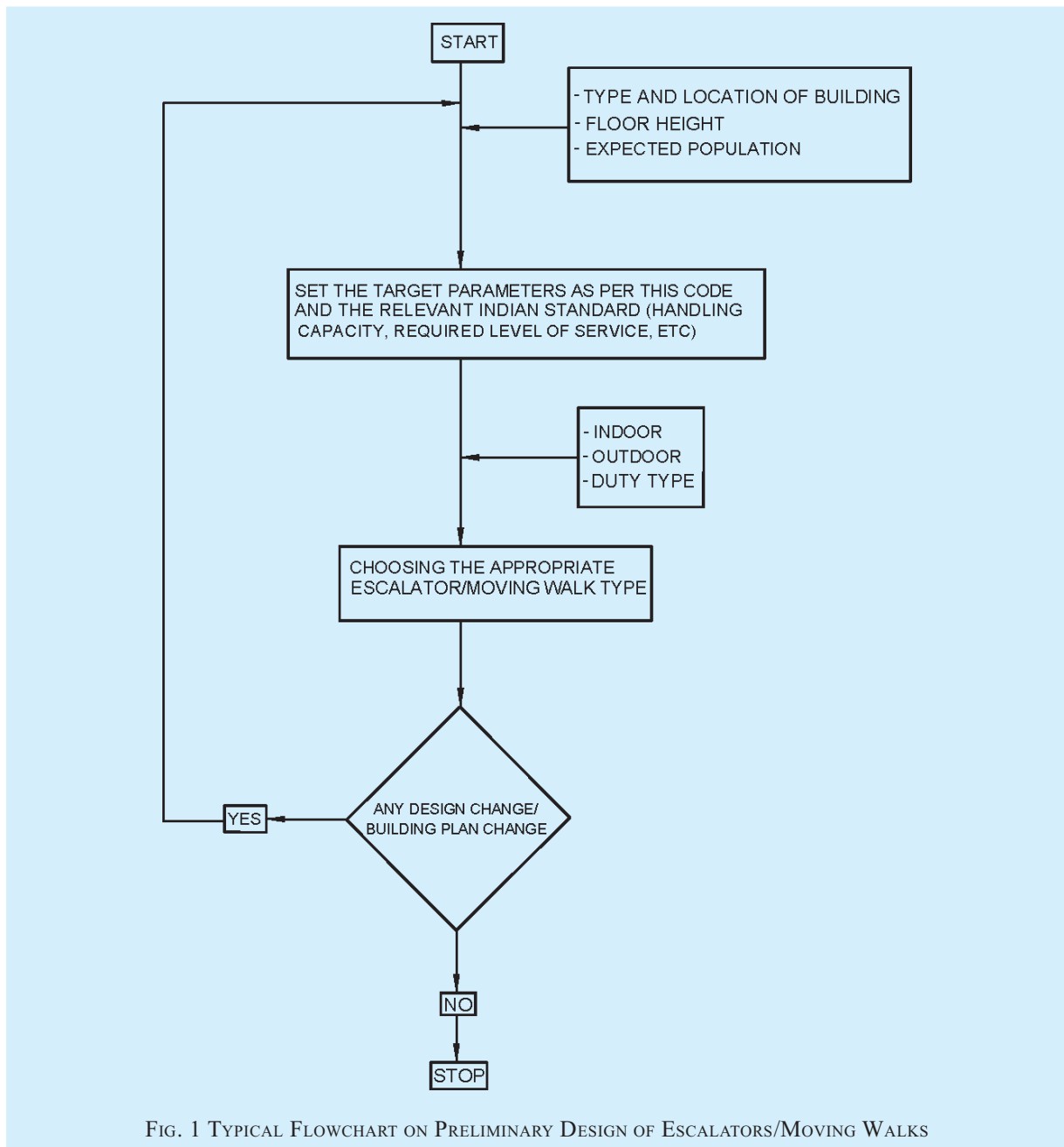

FIG. 1 TYPICAL FLOWCHART ON PRELIMINARY DESIGN OF ESCALATORS/MOVING WALKS

Table 3 Theoretical Capacity for Moving Walks
(Clause 4.3)

Sl No.	Step Width m	Theoretical Capacity, in Persons/h					
		Horizontal Moving Walk (0° Inclination)			Inclined Moving Walk (For 0.5 m/s Speed)		
(1)	(2)	For 0.5 m/s Speed (3)	For 0.65 m/s Speed (4)	For 0.75 m/s Speed (5)	For 6° Inclination (6)	For 10° Inclination (7)	For 12° Inclination (8)
i)	0.8	3 000	3 700	4 400	3 000	3 700	3 000
ii)	1.0	3 800	4 600	5 400	3 700	3 700	—
iii)	1.4	5 100	6 400	7 700	5 100	—	—

Table 4 Practical Capacity for Escalators
(Clause 4.4)

Sl No.	Step Width m	Practical Capacity, in Persons/h		
		For 0.5 m/s Speed (3)	For 0.65 m/s Speed (4)	For 0.75 m/s Speed (5)
(1)	(2)			
i)	0.6	2 250	2 925	3 375
ii)	0.8	3 375	4 388	5 063
iii)	1.0	4 500	5 850	6 750

corridors/walkways, landing and lobby areas, where people do not obstruct other pedestrian circulation routes. Space should be available to accommodate queuing at the boarding point.

It is especially important that the boarding and alighting areas adjacent to an escalator or moving walk are not part of another circulation route, in order to provide a safe area for passengers to board and alight at landings. The area of this space is defined as a distance between the handrails plus 160 mm, multiplied by a depth of 2.0 m to 2.5 m, depending on the configuration of escalator or moving walk.

Figure 2 illustrates the above clause with option 1 being a 2.5 m landing depth and option 2 being 2.0 m landing depth. Where successive units are installed, each successive escalator or moving walk should have its own individual unrestricted area.

Escalators occupy more space than stairs in order to accommodate their inclination. There are few standard escalator arrangements as shown in Fig. 3. Type (a) and Type (b) provide efficient circulation by providing the shortest transition path and time from one escalator and the next. Type (b) requires larger structural opening than Type (a) and Type (c) and present users with a higher risk of falling into the void. Type (c) is typical of a store as it allows the store to lengthen the circulation route past goods for sale. This configuration also takes up free space.

Some moving walks are adopted to receive and lock on shopping/baggage trolleys. In these cases the unrestricted area at the landing should be increased to at least 5 m and number of flat/horizontal steps at the boarding and alighting points increased. The most significant effect is the increased footprint required for the equipment. Shopping/baggage trolleys are not permitted on escalator.

In order to encourage pedestrian confidence and to assist efficient and safe boarding/ alighting of escalators, the start and end of escalator should present a number of horizontal/flat steps. At least two flat steps are provided for escalators speeds up to 0.5 m/s; at least three flat steps for speeds above 0.5 m/s and up to 0.65 m/s for escalator having rise more than 6 m; and at least four flat steps for speeds above 0.65 m/s. In locations where it is anticipated that escalators may be used by persons with impaired mobility or heavy passenger traffic, additional flat steps should be considered.

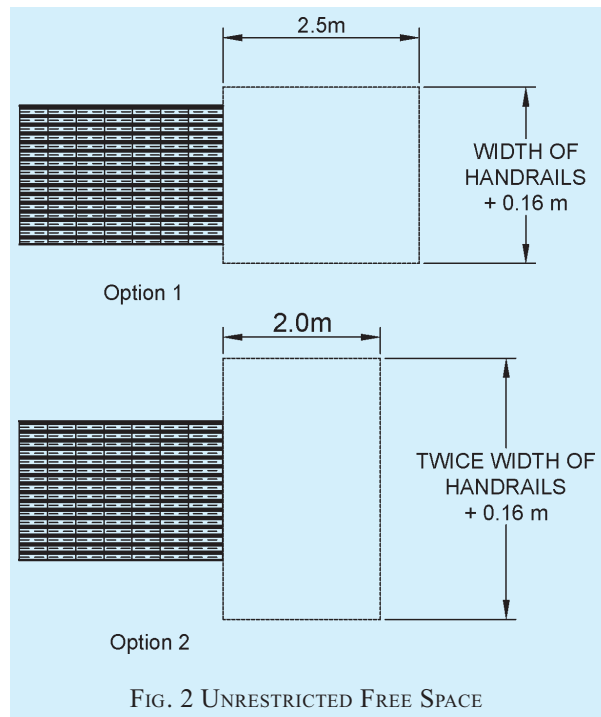

FIG. 2 UNRESTRICTED FREE SPACE

Table 5 Practical Capacities for Moving Walks
(Clause 4.4)

Sl No.	Step Width m	Practical Capacity, in Persons/h					
		Horizontal Moving Walk (0° Inclination)			Inclined Moving Walk (For 0.5 m/s Speed)		
(1)	(2)	For 0.5 m/s Speed (3)	For 0.65 m/s Speed (4)	For 0.75 m/s Speed (5)	For 6° Inclination (6)	For 10° Inclination (7)	For 12° Inclination (8)
i)	0.8	2 880	3 648	4 320	2 880	2 800	2 800
ii)	1.0	3 600	4 560	5 350	3 600	3 600	—
iii)	1.4	5 040	6 350	7 560	5 040	—	—

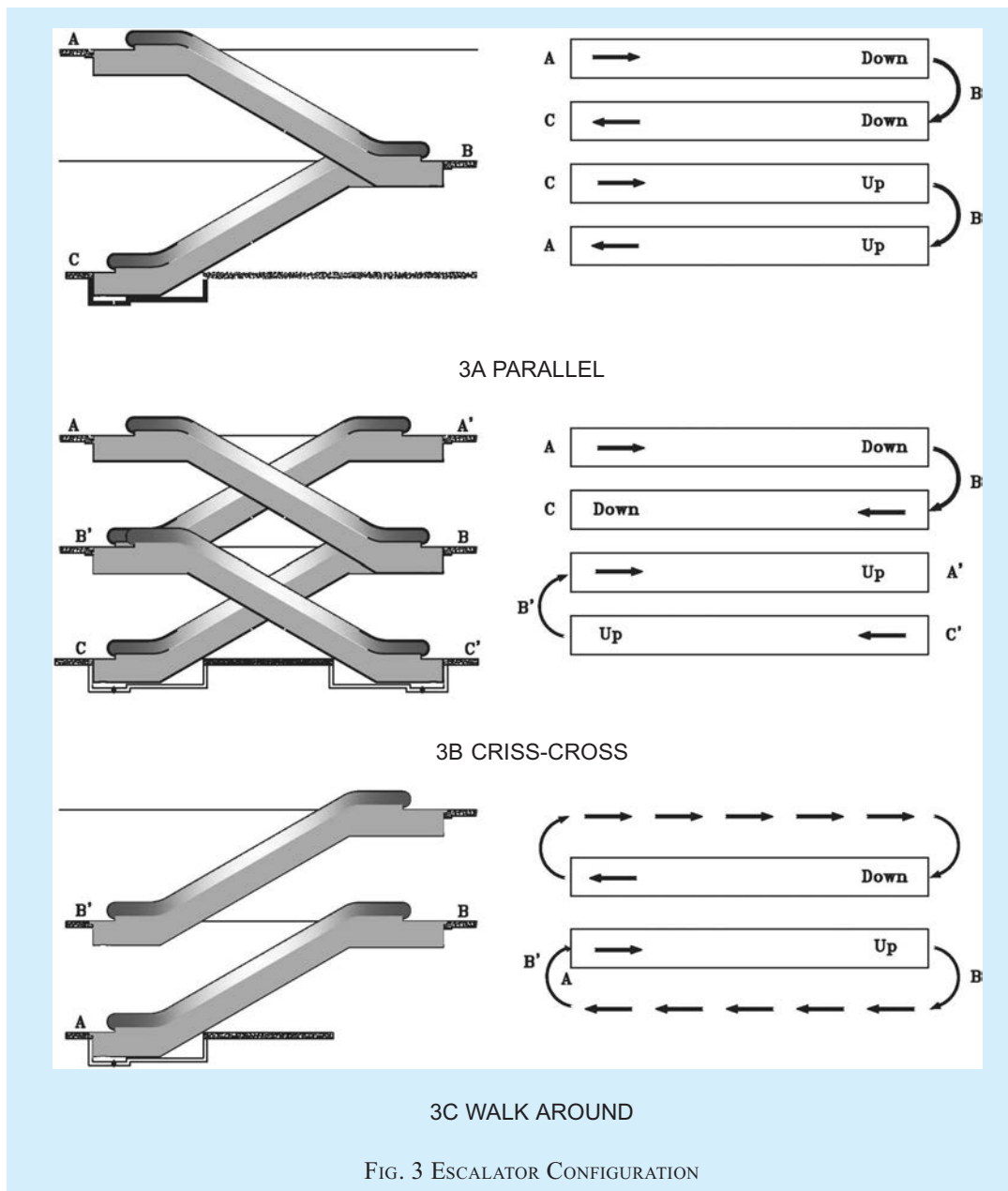

FIG. 3 ESCALATOR CONFIGURATION

5.2 Ensuring Accessibility for All Users

5.2.1 The accessibility requirements given in Part 3 ‘Development Control Rules and General Building Requirements’ of the Code shall be complied with.

5.2.2 The location of escalators and moving walks should be considered in relation to the position of adjacent fire protected lift shafts and lobbies, staircases and their associated areas of rescue assistance, as at the time of an emergency these become non-functional. A surface of the escalator and moving walks should contrast visually with the approach and there should be audible signals or pre-recorded messages that indicate the start and finish of the escalator to help visually impaired people.

For important reasons of safety, special warning notices and tactile warning indicators shall be provided at the top and bottom of escalators. Escalators shall not be considered as the accessible route. Persons with locomotor disability cannot use them. Hence a lift should also be installed as an alternative accessible route.

For moving walks, the maximum inclination should be up to 6° for use by people with disabilities. People with disability may find it difficult to use moving walks. Hence, alternative like an accessible battery cart, may be provided to them in appropriate cases. Moving walks shall be free of projecting objects and obstacles up to a height of 2 100 mm. A minimum level of illumination of 100 lux shall be provided on moving walks.

6 SPACE REQUIREMENT

6.1 Free Space for Users

6.1.1 The clear height above the steps of the escalator or pallets or belt of the moving walk at all points shall be not less than 2.30 m (see X4 in Fig. 4 and Fig. 6). The clear height shall extend to the end of the newel.

NOTE — The clear height of 2.30 m should also be applied to the unrestricted area.

6.1.2 To prevent collision, a minimum free area around the escalator or moving walk is defined as per Fig. 4. The height X12, measured from the steps of the escalator or the pallets or the belt of the moving walk shall be at least 2.10 m (see X12 in Fig. 4). The distance between the outer edge of the handrail and walls or other obstacles (see Y10 in Fig. 4) shall under no circumstances be less than 80 mm horizontally and 25 mm vertically below the lower edge of the handrail (see Y12 in Fig. 7). The area is permitted to be smaller, if by appropriate measures, the risk of injury is minimized.

6.1.3 For escalators arranged adjacent to one another either parallel or criss-cross, the distance between the handrails shall be not less than 160 mm (see Y11 in Fig. 4).

6.1.4 Where building obstacles can cause injuries, appropriate preventive measures shall be taken.

In particular, at floor intersections and on criss-cross

escalators or moving walks, a vertical deflector of not less than 0.30 m in height, not presenting any sharp cutting edges, shall be placed above the handrail level and extend at least 25 mm below the lower edge of the handrail, for example, as an imperforate triangle (see X5 in Fig. 6 and Fig. 8).

It is not necessary to comply with these requirements when the distance Y9 between the outer edge of the handrail and any obstacle is equal to or greater than 400 mm (see Fig. 4).

6.1.5 At the exit(s) of each individual escalator or moving walk a sufficient unrestricted area shall be available to accommodate persons. The width of the unrestricted area shall at least correspond to the distance between the outer edges of the handrails plus 80 mm on each side. The depth shall be at least 2.50 m measured from the end of the balustrade (see Option 1 in Fig. 2). It shall be permissible to reduce it to 2.00 m if the width of the unrestricted area is increased to at least double the distance between the outer edges of the handrails plus 80 mm on each side (see Option 2 in Fig. 2).

For succeeding escalators and moving walks the depth of an unrestricted area shall be determined in each individual case depending on, for example, type of use (persons only or persons with transport devices, number of intermediate exits, relative orientation and theoretical capacity).

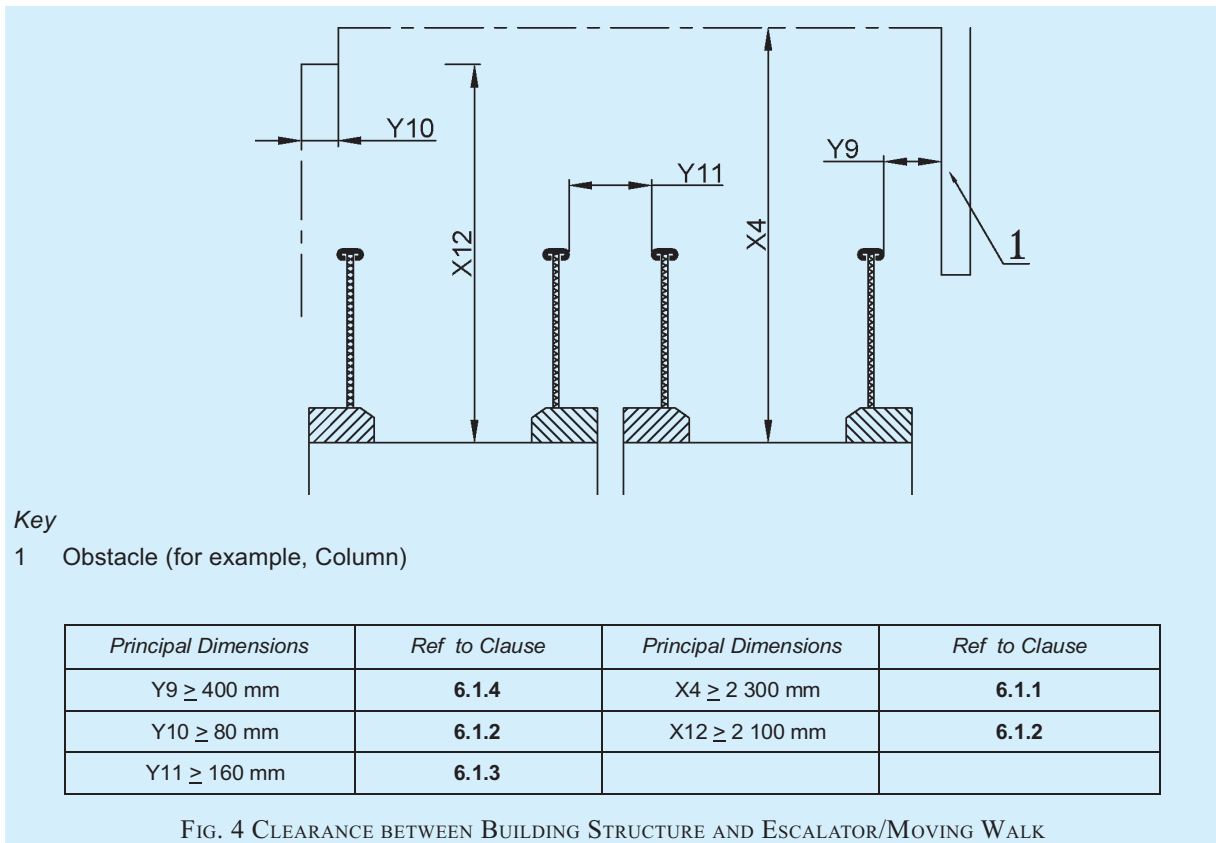

Where the exit of the escalator or moving walk is blocked by structural measures (for example, shutters, fire protection gates) an additional stop switch for emergency situations at handrail level (taking into account 6.1.2) shall be provided with a distance between 2.0 m and 3.0 m before the step/pallet/belt reaches the comb intersection line. This stop switch shall be reachable from inside the escalator/moving walk.

6.1.6 In the case of successive escalators and moving walks without intermediate exits, they shall have the same capacity.

6.1.7 Where it is possible for people to come into contact with the outer edge of a handrail at a landing and can be drawn into a hazardous situation, such as toppling over a balustrade, appropriate preventative measures shall be taken (for example, see Fig. 5).

Some examples are:

- a) Prevention of entry into the space by the placement of permanent barriers.
- b) Increasing the height of the building structure of the fixed balustrade in the hazard area by at least 100 mm above the handrail level and positioned between 80 mm and 120 mm from the outer edge of the handrail

6.1.8 The surrounding space of the escalator or moving walk shall be illuminated, especially in the vicinity of the combs.

NOTE — Information should be exchanged between the manufacturer and the customer.

6.1.9 It is permissible to arrange the lighting in the surrounding space and/or at the installation itself. The intensity of illumination at the landings including the combs shall be related to the intensity of illumination of the general lighting in the area. The intensity of illumination shall be not less than 50 lux at the comb intersection line measured at floor level.

6.2 Machinery Spaces Outside the Truss

The following shall be ensured:

- a) A safe access for persons to machinery spaces shall be provided.
- b) Machinery spaces shall be lockable and only accessible to authorized persons.
- c) Machinery spaces shall be provided with permanently installed electric lighting on the following basis:
 - 1) Minimum of 200 lux at floor level in working areas; and
 - 2) Minimum of 50 lux at floor level in access routes leading to these working areas.
- d) Emergency lighting shall be installed to allow the safe evacuation of all personnel working in any machinery space.

NOTE — Emergency lighting is not intended for continuation of maintenance or other activities.

- e) The dimensions of machinery spaces shall be sufficient to permit easy and safe working on equipment, especially the electrical equipment. In particular these shall be provided at least a clear height of 2.00 m at

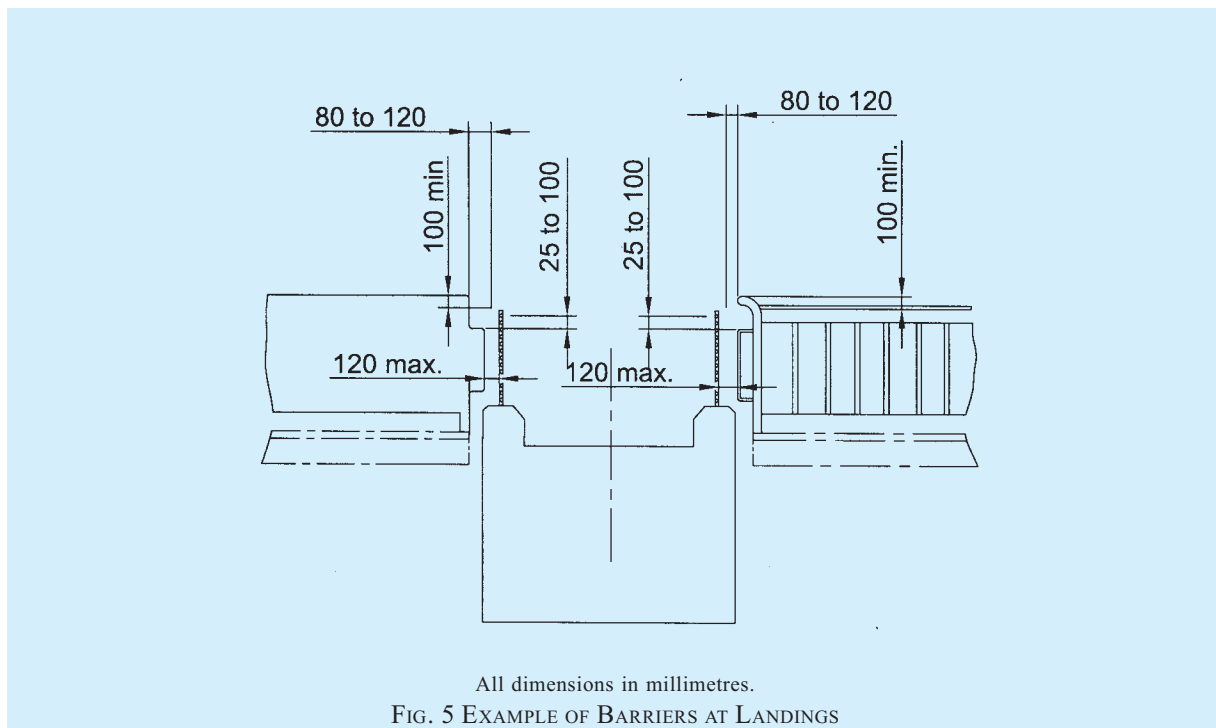

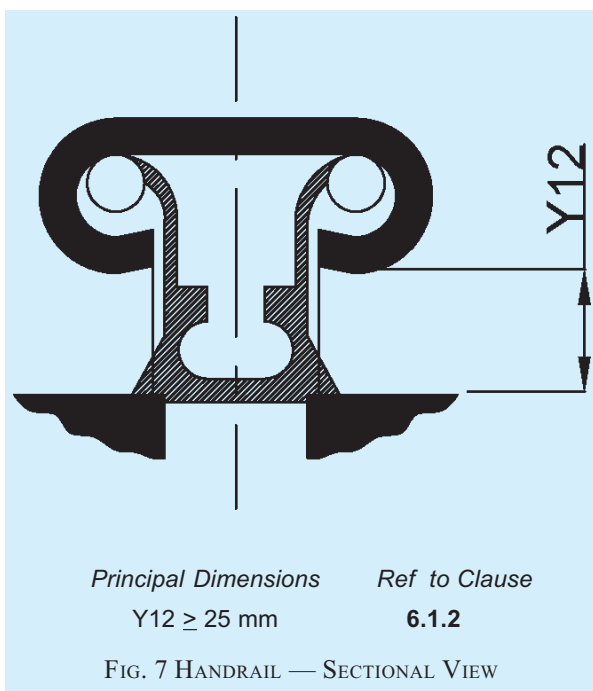
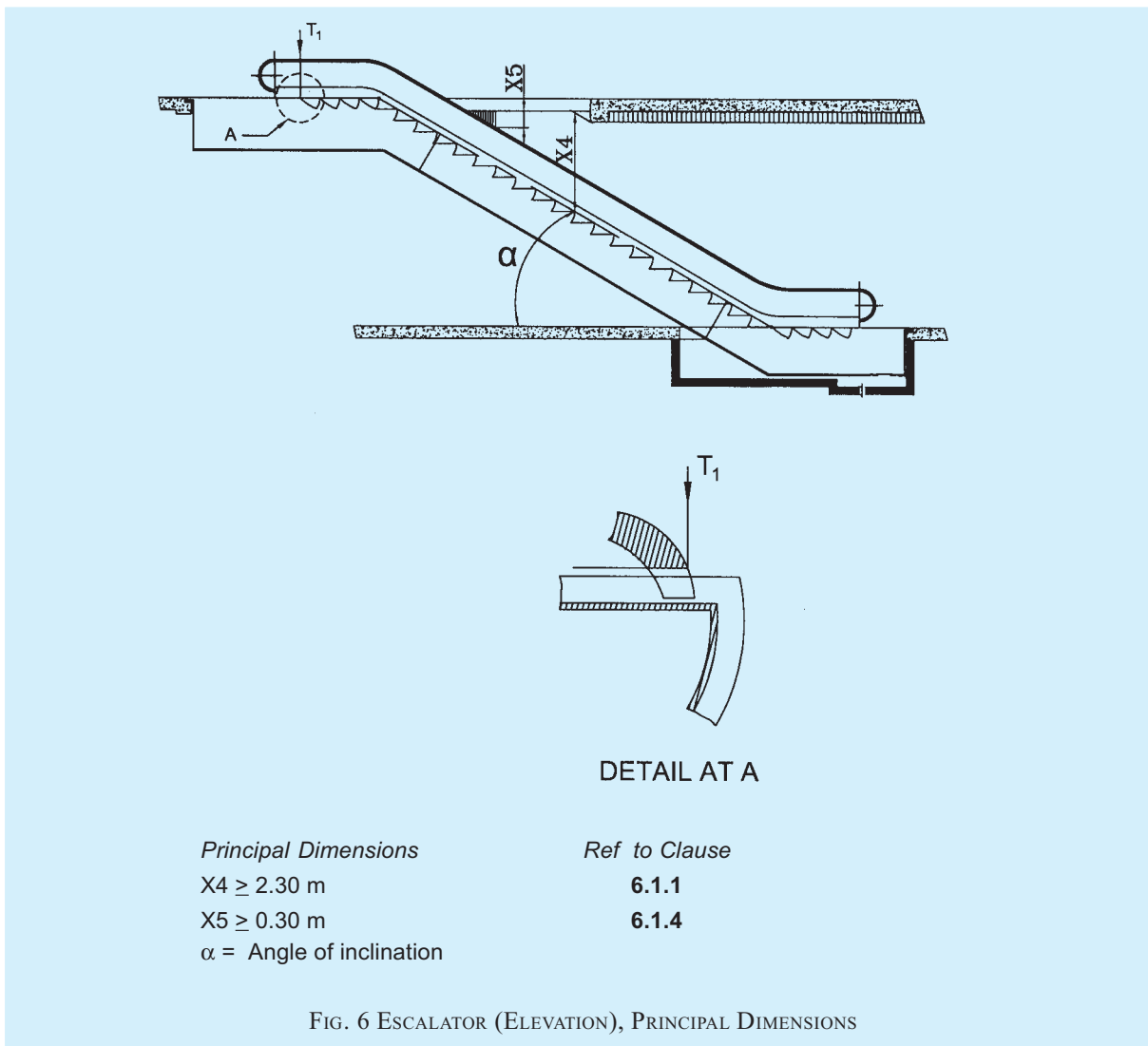

working areas, and a clear horizontal area in front of the control panels and the cabinets. This area is defined as follows:

- 1) Depth, measured : At least 0.70 m; from the external surface of the enclosures
- 2) Width, the greater of : 0.50 m or the full the following values width of the cabinet or panel.

A clear horizontal area of at least 0.50 m x 0.60 m for maintenance and inspection of moving parts at points where this is necessary.

- f) The clear height for movement shall not be less than 1.80 m. The access ways to the clear spaces shall have a width of at least 0.50 m. This value may be reduced to 0.40 m where there are no moving parts. This full height for movement is taken to the underside of the structural roof beams and measured from both,

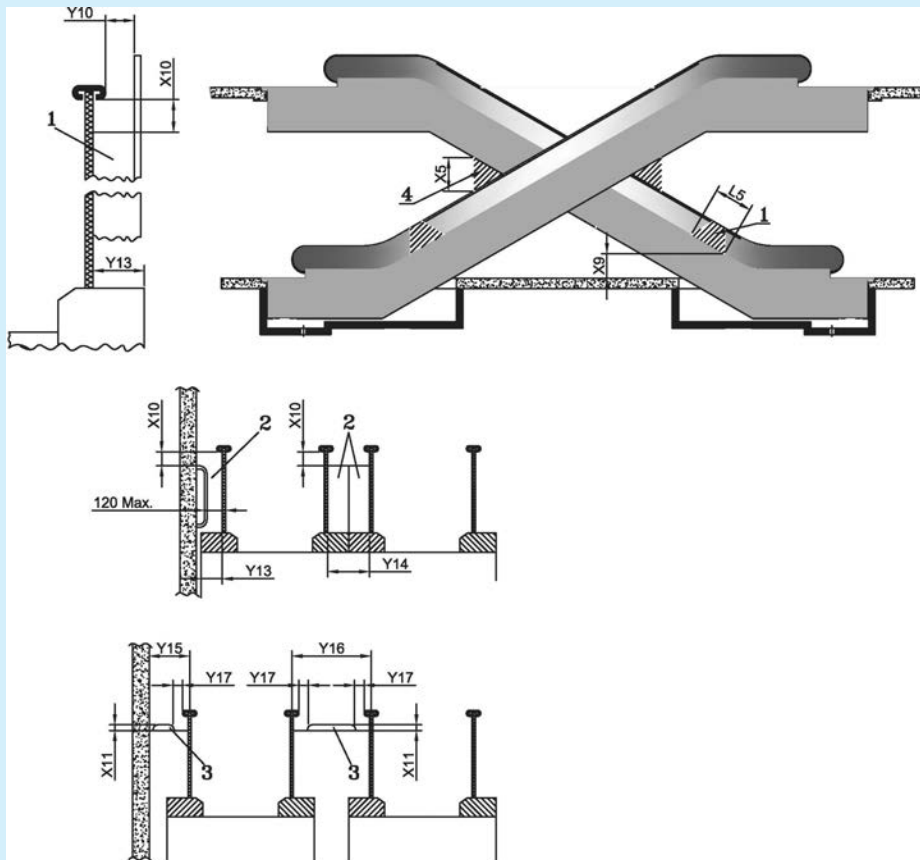

Key

- 1 Anti-climbing device (see 6.3)
- 2 Access restriction device (see 6.3)
- 3 Anti-slide device (see 6.3)
- 4 Vertical deflector (see 6.1.4)

Principal Dimensions	Ref to Clause
Y13, Y14, Y15, Y16	6.3
Y17 ≥ 100 mm	6.3
X5 ≥ 0.30 m	6.1.4
X9 = (1 000 ± 50) mm	6.3
X10 = 25 mm to 150 mm	6.3
X11 ≥ 20 mm	6.3
L5 ≥ 1 000 mm	6.3

FIG. 8 ANTI-MISUSE DEVICES

- 1) the floor of the access area; and
- 2) the floor of the working area.
- g) In machinery spaces the clear height shall under no circumstances be less than 2.0 m.
- h) 3 pin plug with socket for the maintenance propose.
- j) Machinery spaces shall not accommodate equipment not related to the escalator or moving walk.

6.3 Balustrade

Balustrades shall be installed on each side of the

escalator or moving walk. The dimensions of balustrade shall be as follows.

In the inclined section the vertical height X1 from step nose or pallet surface or belt surface to top of the handrail shall be not less than 0.90 m and not exceed 1.10 m (see Fig. 9).

The balustrades shall have no parts on which a person will normally stand.

Appropriate measures shall be taken to discourage people from climbing on the outsides of the balustrade if there is a danger of people falling from them.

To ensure this, on escalators and moving walks, devices (*see 1 in Fig. 8*) shall be provided on the lower outer decking at a point $1\ 000 \pm 50$ mm above the floor level (*see X9 in Fig. 8*) where the bottom of the device intersects with the balustrade decking and shall extend to a length $L5$ of at least 1 000 mm parallel with the balustrade decking where no stepping is possible. The device shall extend to at least a height in line with the top of the handrail not conflicting with the requirements of Y10 and Y12 (*see Fig. 4 and Fig. 7*).

Where escalators or moving walks are located adjacent to walls, devices (*see 2 in Fig. 8*) to restrict access to the balustrade decking shall be provided at the top and bottom ends of these walls when the lower outer decking width Y13 exceeds 125 mm. On adjacent parallel arrangements, this protection shall be provided when the combined balustrade decking width Y14 exceeds 125 mm. The device shall extend to the height X10 (*see Fig. 8*).

All exposed fastener heads for the devices should be of the vandal resistant type.

Where handrail level balustrade decking are provided between escalators/inclined moving walks and adjacent walls, anti-slide devices (*see 3 in Fig. 8*) shall be provided on the balustrade decking when the distance Y15 between the structure of the building (wall) and the centreline of the handrail is greater than 300 mm. These devices shall consist of objects fastened to the balustrade decking, no closer than 100 mm to the handrail (*see Y17*) and spaced no greater than 1 800 mm apart. The height X11 shall be not less than 20 mm. The devices shall have no sharp corners or edges (*see Fig. 8*).

The above mentioned also applies to adjacent escalators/inclined moving walks when the distance Y16 between the centrelines of the handrails is greater than 400 mm.

6.4 Installation

The following needs to be planned and carried out on site to ensure easy installation of escalators and moving walks.

6.4.1 Installation Timing

To prevent damage to the escalator during the construction phase, the timing of installation and assembly should be as close as possible to the opening date. It should, however, proceed completion of the floor so as to dispense with the need to take further measures to protect floor coverings. Ensure that the provisional floors along the transport route in the building can comfortably cope with the load weight.

6.4.2 Transport to the Assembly Site

A suitable unloading area shall be available in front of the building. The access routes to the building shall be level and negotiable by heavy duty rollers. Along the entire transport route to the assembly site, the free height shall not be less than the minimum specified in the manufacturer plan (also goes for pipes and other attachments fitted by others to the ceiling structure).

6.4.3 Access Openings, Transport Route and Load Capacity

Normally, escalators are moved in through openings at the side of the building at ground level. Optionally, suitable roof openings should be provided, in order to

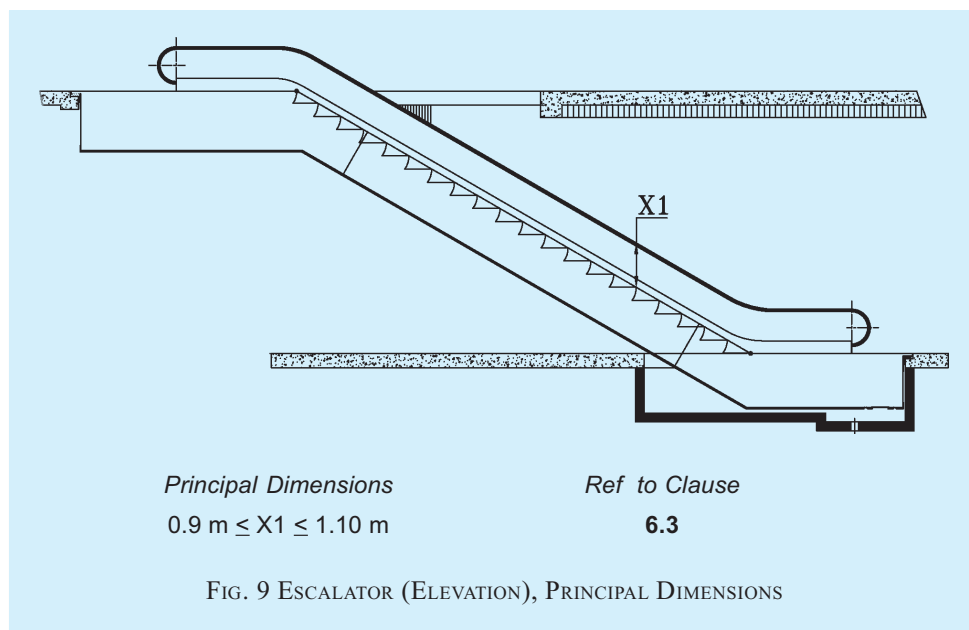

bring the escalators by crane. It is important that the route to the assembly location within the building is free of obstacles and level, and the ceiling can support a load. Otherwise the appropriate weight distribution shall be catered to.

6.4.4 Special Delivery

Some escalators are so long that they have to be installed in sections. In this case, the escalator may have to be manufactured in split form and assembled on site.

6.4.5 Ceiling Openings

Manufacturer should notify the location and size of the required ceiling openings on the installation drawing. Builder shall supervise the precise implementation of these.

6.4.6 Top and Bottom Supports

While designing the support recess, the support loads shall be taken into account. They are shown on the installation drawing given by the manufacturer. At those locations where the supports of escalator (or moving walk) will be placed, the support shall be able to bear the weight of the escalator including traffic load. When preparing the supporting structures the measurements indicated on manufacturer’s installation plans shall be precisely adhered to (see Fig. 10).

6.4.7 Intermediate Supports

Intermediate supports are needed on escalators with a considerable travel height and on long moving walks. The manufacturer shall inform the builder about the installation plan of the location of the intermediate supports and load to include the additional required space in construction plan (see Fig. 11).

6.4.8 Hoisting Arrangement

It has to be ensured that pick-up points for hoisting and supporting the escalator shall be fitted securely during assembly. These should be located exactly above

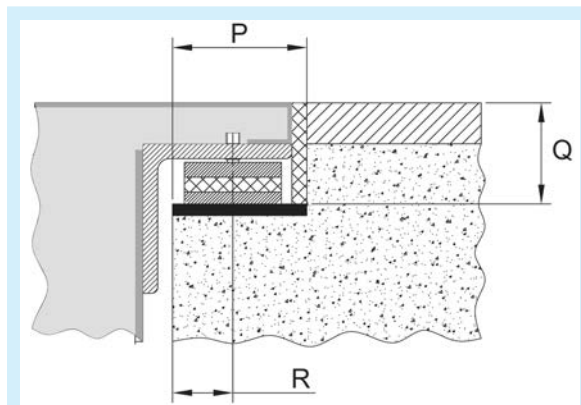

NOTE — P, Q, R = Based on Manufacturing Drawing

FIG. 10 TOP AND BOTTOM SUPPORTS

the centre of the supporting points. For systems with several supporting structures, plan for additional pick-up points above the intermediate supports. All pick-up points shall be capable of taking a load strain (see Fig. 12).

6.4.8.1 Installation with a frame

If no assembly holes can be provided, the escalators and moving walks should be lifted to their final location by means of especially sturdy girder construction. In this case, ceiling load strain shall bear the capacity as per the manufacturer’s instruction.

6.4.8.2 Installation with lifting gear

Holes with a 100 mm diameter are to be made through the ceiling, according to manufacturer instructions. These are used by installation team for fixing the lifting gear. In this way escalator or moving walk is simply lifted upwards from floor to floor. The load strain of every pick-up point shall be maintained as per the manufacturer instruction.

6.4.8.3 Installation with crane assembly

Where a suitable roof opening is available or the site is located outdoor lift the escalator or moving walk by

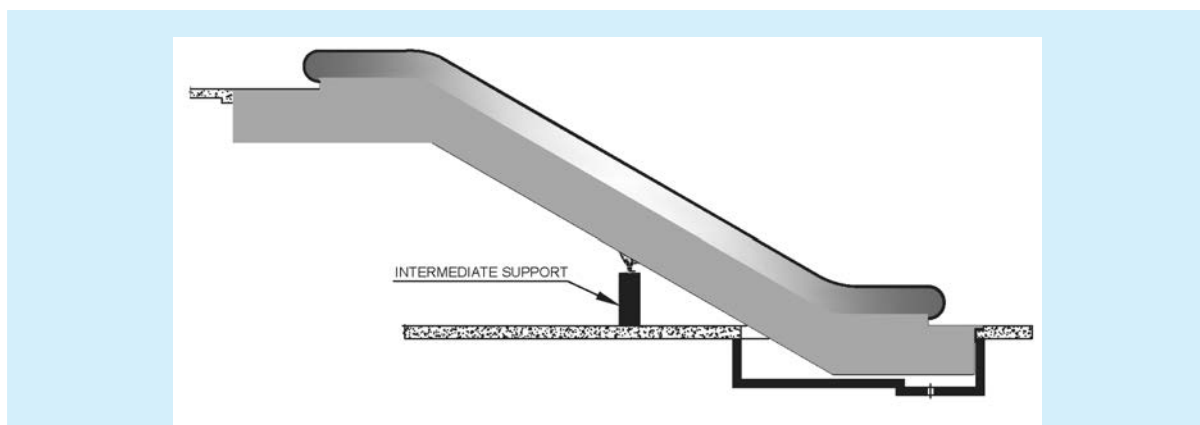

FIG. 11 INTERMEDIATE SUPPORTS

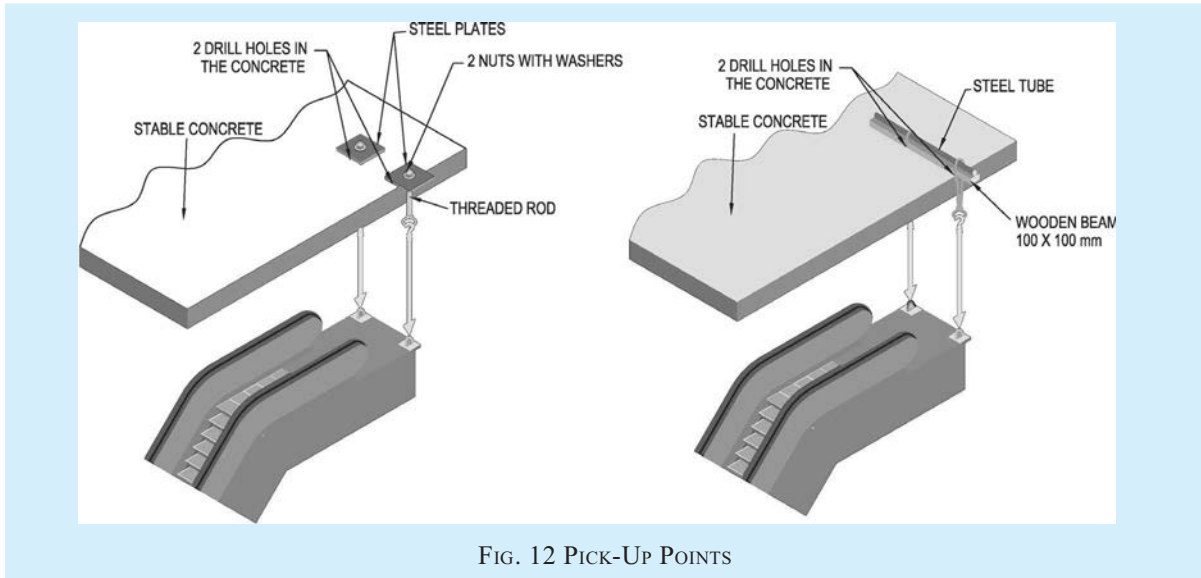

FIG. 12 PICK-UP POINTS

crane and place it on the supports provided. The builder is responsible for ensuring for all local authority approvals.

6.4.8.4 Permanent hoisting hooks shall be provided by the builder in the top slab for hoisting the escalator as per the load requirement.

6.4.9 *Sprinkler Piping*

An optional safety feature is the installation of a sprinkler piping within the escalator or moving walk (see Fig. 13).

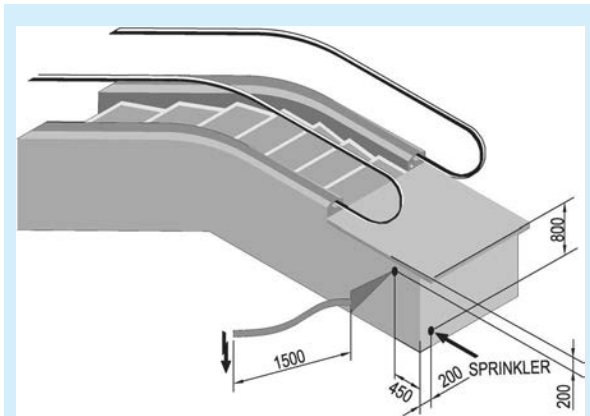

FIG. 13 SPRINKLER PIPING

6.4.10 *Oil Separator*

A type-proofed oil separator is essential for escalators and moving walks which are exposed to the weather. At the construction site, a recess shall be provided for the oil separator in the escalator pit.

6.4.11 *Railings*

In the threshold areas of the escalators, railings have to be installed by the builder. The distance to the

escalator handrail from railing has to be at least 80 mm. For adjacent escalators, the distance between the edges of the handrails shall be at least 160 mm (see Y11 in Fig. 4).

6.5 *Electrical Requirement*

6.5.1 The electrical installations shall be in accordance with Part 8 ‘Building Services, Section 2 Electrical and Allied Installations’ of the Code and good practices [8-5B(1)].

6.5.2 *Power Supply*

Power supply cable with 3 phase 415 $\begin{matrix} +6 \text{ percent} \\ -10 \text{ percent} \end{matrix}$ V and earthing to be laid up to escalator control panel and a single phase 230 V supply for lighting may be necessary, and shall be provided by the concerned party.

6.5.3 *Protection*

Suitable over load and short circuit protection and earth leakage protection needs to be provided in ensuring protection to the power system.

7 *FIRE PROTECTION*

Fire protection and building requirement differ with the application/use of building. For specific requirements for fire protection, Part 4 ‘Fire and Life Safety’ of the Code shall be referred. It is recommended that escalators and moving walks are made of non-combustible material that do not create additional hazard in case of fire.

To limit the danger caused by overheating, ventilation for the spaces that contain the motors and gears shall be provided. Extinguishing systems can be installed in these areas. In case sprinklers are used, their integration and fixation into the escalator and moving walk shall

be done by taking into consideration the special needs of the machine.

Accumulation of materials (such as grease, oil, dust, paper) represent a fire risk. Therefore it should be possible to clean the underside enclosure. If such cleaning is not possible, other precautions (such as installation of sprinkler system) shall be provided to avoid the fire hazard. It is recommended that as far as possible, escalators and moving walks are not used in case of emergency situations.

8 MINIMUM TECHNICAL AND SAFETY REQUIREMENTS

8.1 General

The safety requirements of escalators and moving walks shall comply with good practice in accordance with this Subsection. Certain escalators and moving walks are subject to special operational and environmental conditions.

8.2 Supporting Structures (Truss) and Enclosure

The truss shall be designed to safely sustain steps and running gear in its guides. All mechanically moving parts of the escalator or moving walk shall be completely enclosed within imperforate panels or walls. Exceptions are the accessible steps, the accessible pallets, the accessible belt and that part of the handrail available for the user. Apertures for ventilation are permitted. However, it shall not be possible to pass a straight rigid rod 10 mm in diameter through the enclosure and to touch any moving part through a ventilation aperture.

The supporting structure shall be designed in a way that it can support the dead weight of the escalator or moving walk plus a rated load of 5 000 N/m². Based on the rated load, the maximum calculated or measured deflection shall not exceed 1/750 of the distance between the supports. Angle of inclination of an escalator from the horizontal shall not exceed 30°, but for rises not exceeding 6 m and nominal speed not exceeding 0.5 m/s the angle of inclination is permitted to be increased to 35°.

Rise m	Speed m/s	Angle of Inclination	
		Standard	Option
≤ 6	≤ 0.5	30°	35°
≤ 6	> 0.5	30°	—
> 6	≤ 0.5	30°	—
> 6	> 0.5	30°	—

The angle of inclination of moving walks shall not exceed 12°.

8.3 Step, Pallet or Belt

For escalators and moving walks, the nominal width shall be not less than 0.58 m and not exceed 1.10 m. For moving walks with an angle of inclination up to 6°, widths up to 1.65 m are permitted.

8.3.1 Step Treads and Pallets

The step depth in the direction of travel shall not be less than 0.38 m. The step height shall not exceed 0.24 m. The surface of the step treads shall have grooves in the direction of the movement, with which the teeth of the combs mesh. They shall be sensibly horizontal in the usable area of the escalator. The step risers shall be cleated and the surface of the cleat shall be smooth. The ends of the step tread shall mesh with the cleating of the next step riser.

The width of the grooves shall be at least 5 mm and shall not exceed 7 mm. The depth of the grooves shall not be less than 10 mm. The web width shall be at least 2.5 mm but not exceed 5 mm.

8.3.2 Belts

The belts shall have grooves in the direction of travel with which the teeth of the comb mesh. The width of the grooves shall be at least 4.5 mm and shall not exceed 7 mm. The depth of grooves shall not be less than 5 mm. The web width shall be at least 4.5 mm but not exceed 8 mm. Splicing of tread way belt shall be such as to provide continuous unbroken tread way surface.

8.4 Driving Machine and Brake

8.4.1 A driving machine shall not drive more than one escalator or moving walk.

8.4.2 The speed of an unloaded escalator shall not deviate by more than ± 5 percent from nominal speed at nominal frequency and nominal voltage. The nominal speed of the escalator shall not exceed 0.75 m/s for an angle of inclination up to 30° and 0.5 m/s for an escalator with an angle of inclination of more than 30° but within 35°. The nominal speed of moving walk shall not exceed 0.75 m/s.

Deviating from the above nominal speed up to 0.90 m/s is permitted provided the width of the pallets or the belt does not exceed 1.10 m and at the landings, the pallets or the belt move horizontally for a length of at least 1.60 m before entering the combs.

8.4.3 The driving machine shall be connected to main drive shaft, preferably by non-friction driving elements such as by gear wheels, shaft, coupling, multiplex chain, two or more single chains. Where friction elements are used such as trapezoidal belts (flat belts are not permitted) an auxiliary brake shall be used.

Safety factors of all driving elements shall be at least

5 for static calculations. In the case of trapezoidal belts, at least 3 belts shall be applied.

8.4.4 Braking System

Escalators and moving walks shall have an operational braking system by means of which they can be brought to rest with a uniform deceleration and maintained stationary; there shall be no intentional delay in the application of the braking system. If the control system starts a braking sequence immediately to bring the escalators/moving walk to a stop, this is not considered as an intentional delay. A device shall be provided to monitor the lifting of the braking system after starting the escalator/moving walk.

Operational braking shall be effected by an electro-mechanical brake or by other means. Where no electro-mechanical operational brake is used, an auxiliary brake shall be provided.

8.4.4.1 Auxiliary brake

Escalators and inclined moving walks shall be equipped with auxiliary brake(s) if:

- a) the connection between the operational brake and the driving sprockets of the steps/pallets or the drum of the belt is not accomplished by shafts, gear wheels, multiplex chains, or more than one single chain;
- b) the operational brake is not an electro-mechanical brake;
- c) the rise exceeds 6 m; or
- d) escalators or moving walks are part of a public transport/service system.

The connection between the auxiliary brake and the driving sprockets of the steps/pallets or the drum of the belt shall be accomplished by shafts, gear wheels, multiplex chains or more than one single chain. It is not permissible for the connection to comprise friction drives, that is, clutches.

8.5 Steps and Pallets Drive

The steps of escalators shall be driven by at least two chains of which at least one shall be located on each side of the step. The pallets of moving walks may be permitted to be driven by only one chain, if the parallel movement of the pallets in the usable area is ensured by other mechanical measures.

The step chain design shall be of nominally infinite fatigue life.

The safety factor against breaking of each chain shall be at least 5. When more than one chain is used it is assumed that the load is equally distributed over the chains.

8.6 Belt Drive

The belt shall be driven by drums and be tensioned continuously and automatically. Springs working in tension are not permitted for the tensioning device. When weights are used for tensioning they shall be safely retained should their suspension break. The factor of safety of the belt including splicing shall be at least 5 for the dynamic forces.

8.7 Balustrade

8.7.1 Balustrades shall be installed to comply with the requirements of 6.3.

8.7.2 The horizontal distance (measured at right angles to the direction of travel) between the interior panel at lower points shall be equal to or less than the horizontal distance measured at points higher up.

8.7.3 The parts of the balustrade facing the steps shall be smooth. Covers or strips not in the direction of travel shall not project more than 3 mm. They shall be sufficiently rigid and have rounded or bevelled edges. Cover or strips of such nature are not permitted at the skirting. Cover joints in the direction of travel (in particular between the skirting and balustrade interior panelling) shall be arranged and formed in such a manner to eliminate the risk of injury caused by trapping.

Gap between interior panels of the balustrade shall not be wider than 4 mm. The edges shall be rounded off or bevelled. The balustrade interior panelling shall have adequate mechanical strength and rigidity. When a force of 500 N is applied at any point of the panelling at right angles on an area of 2 500 mm², there shall be no gap greater than 4 mm and no permanent deformation (setting tolerance however, are permitted).

If glass is used for the interior panel it shall be toughened glass. In case of splinter free one layer safety (tempered) glass, the minimum thickness shall be 6 mm. When multi-layer glass balustrades are used, they shall be laminated toughened glass, the thickness of at least one layer shall also be not less than 6 mm.

8.8 Skirting

The skirting shall be vertical, plain and sufficiently rigid. Where the skirting of escalators or moving walks is placed beside the steps and pallets or the belt the horizontal clearance shall not exceed 4 mm at either side, or 7 mm for the sum of clearances measured at both sides at two directly opposite points.

Where the skirting of moving walks finishes above the pallets or the belt, the clearance shall not exceed 4 mm measured vertically from the tread surface. Motion of the pallets or the belt in lateral direction shall not cause

a gap between the sides of the pallets or the belt and the vertical projection of the skirting

8.8.1 Requirements for Skirt Deflectors

The deflectors shall be designed with rounded edges. Fastening heads and joint connections shall not extend into the path of travel. They shall consist of a rigid and a flexible part (for example, brushes and rubber profiles). They shall have a minimum projection of 33 mm and a maximum of 50 mm from the vertical face of the skirt panels. The terminal end piece shall be tapered to give a flush interface with the skirting. The terminal end piece of any deflector device shall end not less than 50 mm and maximum 150 mm prior to the comb intersection line.

8.9 Handrails

Each balustrade shall be provided with a handrail moving, on the top of each balustrade, in the same direction and at the same speed, within tolerance of $^{+2}_0$ percent, as the steps, pallets or belt. Each moving handrail shall extend at normal handrail height not less than 300 mm beyond the line of point of comb plate teeth at the upper and lower landings. Hand or finger guards shall be provided at the points where handrails enter the balustrade.

The width of handrail shall be between 70 mm and 100 mm. The distance between the handrail and the edge of the balustrade shall not exceed 50 mm. The handrail shall be a minimum of 80 mm horizontally and 25 mm vertically away from adjacent surfaces (*see* Fig. 5). The distance between centreline of handrails shall not exceed the distance between the skirting by more than 0.45 m. The handrail shall be guided and tensioned in such a way that it does not leave its guides during normal use.

8.10 Landing

The landing area (that is, comb plate and floor plate) of escalator shall have a surface that provides a secure foot hold (combs are exempted from this) for a minimum distance of 0.85 m measured from the root of the comb teeth.

8.10.1 Configuration of Steps, Pallets and Belts

8.10.1.1 At the upper and lower landing, the steps of the escalator shall be guided in such a way that the front edges of the steps leaving the comb and the rear edges of the steps entering the comb are moving horizontally for a length of at least 0.80 m measured from point T1 (*see* Fig. 6 and detail A).

At nominal speeds above 0.50 m/s and not more than 0.65 m/s or rises above 6 m, this length shall be at least 1.20 m, measured from point T1 (*see* Fig. 6 and detail A).

At nominal speeds above 0.65 m/s this length shall be at least 1.60 m measured from point T1 (*see* Fig. 6 and detail A).

A vertical difference in level between two consecutive steps of 4 mm is permitted.

8.10.1.2 For escalators, the radius of curvature in the upper transition from incline to horizontal shall be,

- at least 1.00 m for nominal speeds $v \leq 0.5$ m/s (inclination of maximum 35°);
- at least 1.50 m for nominal speeds $0.5 \text{ m/s} < v \leq 0.65 \text{ m/s}$ (inclination of maximum 30°); and
- at least 2.60 m for nominal speeds $v > 0.65 \text{ m/s}$ (inclination of maximum 30°).

The radius of curvature in the lower transition from incline to horizontal of the escalator shall be:

- at least 1.00 m for nominal speeds $v \leq 0.65 \text{ m/s}$; and
- at least 2.00 m for nominal speeds $v > 0.65 \text{ m/s}$.

8.10.1.3 For belt moving walks, the radius of curvature in the transition from incline to horizontal shall be at least 0.40 m.

For pallet moving walks, it is not necessary to determine the radius of curvature because, on account of the maximum permissible distance between two consecutive pallets, it will always be sufficiently large.

8.10.1.4 At the upper landings of moving walks with an inclination of more than 6°, the pallets or belt shall move for a length of at least 0.40 m at a maximum angle of 6° before entering or after leaving the comb.

8.11 Comb Plates

There shall be a comb plate at the entrance and at the exit of every escalator. The comb plate teeth shall be meshed with and set into the tread surface so that the points of the teeth are always below the upper surface of the treads. The comb plates shall be adjustable. Combs shall be easily replaceable.

8.12 Speed Governor

8.12.1 Where speed control devices are used for this purpose, they shall have switched off the escalator before the speed exceeds 1.2 times the nominal speed. This requirement may not be applied if the design prevents the excessive speed.

8.12.2 Escalators and inclined ($\alpha \geq 6^\circ$) moving walks shall be equipped in such a way that they stop automatically by the time the steps and pallets or the belt change from the pre-set direction of travel.

8.12.3 For operation and safety devices, electrical work, precautions and tests, reference may be made to good practice [8-5B(2)].

8.13 Inspection Control

Escalators or moving walks shall be equipped with inspection controls to permit operation during maintenance or repair or inspection by means of portable and manually operated control devices. At least one portable control device shall be provided for each escalator or moving walk.

For this purpose, one inspection outlet for the connection of flexible cable of the portable manually operated control device shall be provided at least at each landing, for example, in the driving station and the return station in the truss. The length of the cable shall be at least 3.00 m. Inspection outlets shall be located in such a way that any point of the escalator or moving walk can be reached with the cable.

8.14 Information for Use

8.14.1 General

All escalators and moving walks are required to be provided with documentation that shall include an instruction handbook relating to use, maintenance, inspection, periodic checks and rescue operations. Information for use shall cover, separately or in combination, transport, assembly and installation, commissioning, use (setting, teaching/programming, operation, cleaning, fault finding and maintenance) of the escalator and moving walk, and, if necessary, de-commissioning, dismantling and disposal.

8.14.2 Signals and Warning Devices

8.14.2.1 Plates, inscriptions and notices for use

- a) *General* — All signs, inscriptions and notices for use shall be of durable material, placed in a conspicuous position and written in clearly legible characters in English as well as in local language.
- b) *Safety signs near the entrances of escalators or moving walks* — The following mandatory action signs and prohibition signs for the user shall be fixed in the vicinity of the entrances:
 - 1) Small children shall be held firmly (*see Fig. 14*);
 - 2) Pets shall be carried (*see Fig. 15*);
 - 3) Use the handrail (*see Fig. 16*); and
 - 4) Push chairs not permitted (*see Fig. 17*).

When required by local conditions, prohibition signs, for example, ‘Transportation of bulky and heavy loads not permitted’ and mandatory action signs like ‘Use permitted only with footwear’, shall be necessitated.

The minimum diameter of the signs shall be 80 mm.

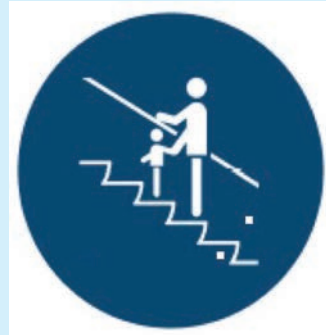

FIG. 14 MANDATORY ACTION SIGN
‘SMALL CHILDREN SHALL BE HELD FIRMLY’



FIG. 15 MANDATORY ACTION SIGN
‘PETS SHALL BE CARRIED’



FIG. 16 MANDATORY ACTION SIGN
‘USE THE HANDRAIL’



FIG. 17 PROHIBITION SIGN
‘PUSH CHAIRS NOT PERMITTED’

Stop devices shall be coloured red either on the device itself or in its immediate vicinity and be marked with the inscription 'STOP'.

During maintenance, repair, inspection or similar work, the access to the escalator or moving walk shall be barred to unauthorized persons by devices which shall bear the notice 'No Access' or the 'No Entry' indicator, and be available in immediate area.

NOTE — The safety sign (see Fig. 18) shall be affixed prominently near the entrances of escalators or moving walks which are inclined above 6°:



FIG. 18 WHEEL CHAIR USERS NOT PERMITTED

- c) *Instructions for hand winding devices* — If a hand winding device is provided, operating instructions for use shall be available in the vicinity. The direction of travel of the escalator or moving walk shall be indicated clearly.
- d) *Notices on the access doors to machinery spaces outside the truss, driving and return stations* — On access doors to machinery spaces outside the truss, and driving and return stations, a notice shall be fixed with the inscription reading, 'MACHINERY SPACE — DANGER' and 'ACCESS PROHIBITED TO UNAUTHORIZED PERSONS'.

9 SPECIAL TECHNICAL REQUIREMENTS

If escalators or moving walks are intended to be operated under special conditions, such as directly exposed to the weather or explosive atmosphere, or in exceptional cases serve as emergency exits, appropriate design criteria, components, materials and instructions for use should be used that satisfy the particular conditions.

9.1 Escalators or Moving Walks for Public Transport

For escalators and moving walks for public transport which,

- a) are part of a public transport system including entrance and exit points; or

- b) are suitable for intensive use, regularly operating for approximately 140 h/week with a load reaching 100 percent of the brake load for a total duration of at least 0.5 h during any time interval of 3 h.

It is recommended to install auxiliary brakes also for rises less than 6 m. Auxiliary brakes shall be mandatory for public transport. The load conditions and additional safety features should be agreed to between the manufacturer and the owner reflecting the traffic levels which exist.

9.2 Measures to Prevent Access of Shopping Trolleys and Baggage Carts

9.2.1 General

If there is a reasonable foreseeable risk that shopping trolleys and/or baggage carts can be taken onto escalators or moving walks, adequate measures shall be taken to eliminate risks and access shall be prevented, if the following conditions are given:

- a) *For escalators* — Where shopping trolleys or baggage carts are available in the area around; and where shopping trolleys or baggage carts are in an area not close to the escalator but it is reasonably foreseeable that they are taken onto the escalator.
- b) *For moving walks* — Where shopping trolleys or baggage carts are not intended to be used on a moving walk.

9.2.2 Barriers

If barriers are used, the following requirements shall be fulfilled:

- a) Barrier shall be installed at the entrance only. An installation at the exit is not permitted in the unrestricted area.
- b) Design of the barrier shall not create another risk.
- c) Free entrance width between ends of the newels and barriers and between barriers itself, shall be at least 500 mm and less than the width of the type of shopping trolley or baggage cart to be used.
- d) Height of the barrier shall be between 900 mm and 1 100 mm.
- e) Barrier and its fixation have to withstand the following load: At a height of 200 mm a horizontal force of 3 000 N applies. This force results from an impact of a chassis of a shopping trolley/baggage cart loaded with 160 kg moving with a speed of 1.00 m/s.
- f) Barrier shall be fixed preferably at the building

structures. It is also permitted to fix it at the floor plate. In that case, when the defined forces apply, there shall be no permanent deformation and increased/additional gaps.

- g) If the escalator/moving walk is dedicated to operate in both directions, the presence of the removable barrier shall be electrically monitored preventing wrong positioning of the barrier resulting in operation towards the barrier, except when under maintenance condition.

9.2.3 Fixed Devices

Where fixed devices such as guiding barriers and/or traffic columns are necessary in the unrestricted area, their design shall not create another risk. The following requirements shall be complied with:

- a) Guiding barriers or traffic columns shall have a minimum horizontal distance (radius) of 500 mm to any point of the handrail and shall be positioned outside of the centre line of the handrail.
- b) Minimum horizontal distance (radius) to any point of the handrail may be reduced to 300 mm, provided that the guiding barriers or traffic columns are positioned outside of the centre lines of the handrails and an additional barrier is installed between the guiding barriers or traffic columns and the vertical centre line of the balustrade newel.

The additional barrier shall have a lateral distance between 80 mm and 120 mm of the handrail outer edge and shall close at least the area between the actual lowest point of the handrail entry into the newel and the balustrade decking profile and shall have filled inlets with gaps less than 25 mm.

- c) Minimum horizontal distance (radius) to any point of the handrail may be reduced to 180 mm, provided that the guiding barrier or traffic column is positioned outside of the outer edge of the handrail and an additional barrier is installed between the guiding barrier or traffic column and the vertical centre line of the balustrade newel.

The additional barrier shall have a lateral distance between 80 mm and 120 mm of the handrail outer edge and shall close at least the area between the actual lowest point of the handrail entry into the newel and the balustrade decking profile and shall have filled inlets with gaps less than 25 mm.

- d) Minimum horizontal distance (radius) to any point of the handrail may be reduced to 100

mm, provided that the guiding barrier or traffic column is of a round shape and is positioned outside of the outer edge of the handrail and an additional barrier is installed between the guiding barrier or traffic column and the vertical centre line of the balustrade newel

The additional barrier shall have a lateral distance between 80 mm and 120 mm of the handrail outer edge and shall close at least the area between the actual lowest point of the handrail entry into the newel and the balustrade decking profile and shall have filled inlets with gaps less than 25 mm

In addition, the following specific requirements shall apply:

- 1) Devices and its fixation shall withstand a horizontal force of 1 kN/m applied to the top of the device.
- 2) Barrier shall be fixed preferably at the building structures. It is also permitted to fix it at the floor plate. In that case, when the defined forces apply, there shall be no permanent deformation and increased/additional gaps.
- 3) Height of traffic columns shall be at least the height of the handrail level.
- 4) Height of guiding barriers shall be at least the height of the balustrade decking.
- 5) If fixed devices are placed inside the unrestricted area, the size of the unrestricted area shall remain the same and in this case be extended in the length.
- 6) Guiding barriers and traffic columns are not considered as structural measures that block the exit.

NOTE — For fixed devices in the immediate environment of the unrestricted area these requirements also apply.

9.3 Escalators and Moving Walks Subject to Seismic Conditions

9.3.1 Structural Requirements

- a) *General* — Escalators and moving walks, if specified to meet specified seismic conditions, shall comply with the relevant safety requirements and/or protective measures as listed below.
- b) *Pit/support* — Pit and support conditions are to be secured in that way that the escalator and moving walk under seismic condition is not subjected to constraint. One support has to be executed as fixed support the other supports are to be executed as movable support in horizontal direction. The supporting conditions need to be simply statically

determinate.

Escalator and moving walk shall be retained on the supports in vertical direction by adequate measures so that the unit cannot jump off the supports under seismic conditions.

- c) *Arrangement* — The length and the movability of the escalator and moving walk have to be chosen in accordance with the building movement between two storeys of the building. The minimum allowable compensation length of the movable support of the escalator and moving walk has to be chosen same as the maximum allowed storey drift of the building.
- d) *Mechanical safety devices for escalators and moving walks* — If the design of the escalator and moving walk does not allow the safe situation in the pit or support an additional safety device need to be applied so that the escalator and moving walk cannot fall off the support.

9.3.2 Design Requirements

It is assumed that negotiations have been made for each contract between the customer and the supplier/installer about the peak ground acceleration to be considered. The building designer or owner shall provide the design acceleration which shall be documented in the information. Client and supplier/contractor have to agree on one common acceleration value. The acceleration value need to be communicated between all participants of the contract. Also,

- a) the design of the truss for the escalators and moving walks shall be sufficiently executed for the ambient seismic condition. The structural design shall provide a dissipation capacity to withstand a design-relevant earthquake of the region where it is located.
- b) *Drive and control unit* — Machinery [including control cabinet(s) and drive system, machine, main switch(es), and means for emergency operations], free-wheeling switch shall be designed and anchored to prevent overturning and displacement as a result of the forces imposed on them including forces generated by the design acceleration.
- c) *Electrical installation and other equipment* — In case the building where the escalator and moving walk will be installed is equipped with a seismic detector/sensor, the electrical system of the unit shall provide an interface for the connection and shall stop the escalator and moving walk in case of seismic activity.

9.4 Escalator/Moving Walk Interface with Building Management System (BMS)

Where required, a means to interface, monitor and control be provided by the escalator/moving walk manufacturer, which should become the part of building management system. Following information and controls, but not limited to these, may be provided either through potential free contacts or building automation interface device suitable for providing necessary escalator/moving walk information over accepted communication protocols:

- a) *Monitoring signals:*
 - 1) Power status,
 - 2) Running up/down (Escalator),
 - 3) Running forward/backward (Moving walk),
 - 4) Under maintenance,
 - 5) Under fault, and
 - 6) Emergency 'STOP' pressed.
- b) *Remote operation* — Escalator or moving walk shall not be started or stopped from remote monitoring station using remote signal, unless the particular escalator/moving walk operation is visible/monitored from the remote station.

10 PERFORMANCE REQUIREMENTS FOR ESCALATORS AND MOVING WALKS

10.1 It is necessary to have uniformity in the definition, measurement, processing and expression of vibration and noise signals that comprise escalator and moving walk ride quality. The aim of such uniformity is to benefit escalator and moving walk users by reducing variability in the results of ride quality measurements caused by differences in the methods of acquiring and quantifying the signals. Experience indicates that passenger perception and sound pressure levels measured while travelling on an escalator or moving walk can be influenced by the presence of extraneous noise and vibration sources and by acoustic characteristics of the environment in which the unit is installed and operated. Additionally, the proximity of the escalator or moving walk to strong reflecting surfaces such as walls, ceilings or diagonally opposite units can also influence the sound pressure level measured. These influences can cause a sound pressure level measurement to significantly overestimate the sound level emitted exclusively by the unit. In order to address this issue, this Subsection defines the methodology for measuring vibration and sound pressure level that corresponds to passenger perception and additionally defines the methods that should be used, if further understanding of the result is required in order to quantify vibration and noise emitted by the

unit as compared to the background or environmental contributions.

10.2 Measurement of Escalator and Moving Walk Ride Quality

Escalator and moving walk should be measured in both running directions except where the unit is designed to operate in one direction only. The measurements should be carried out under following conditions where, escalator and moving walk shall,

- a) be assembled completely, adjusted and operating in accordance to the requirement;
- b) have reached normal operating temperature;
- c) be measured in unloaded condition;
- d) be measured after starting sequence has been completed. If the unit operates at different speeds, all the speeds shall be measured;
- e) have finished star/delta changeover, if used, before starting the measurement;
- f) have vibration measurements made by aligning the axis of transducer to the axis of entire escalator or moving walk; and
- g) have the noise measured at measuring distance to the floor/surface of steps and pallets of 1.55 ± 0.075 m.

11 ESCALATOR AND MOVING WALK ENQUIRY OR INVITATION TO TENDER

11.1 A period of two to four weeks is normally sufficient for return of tenders. This should be extended, if large numbers of escalators/moving walks or special requirements are involved. The enquiry documents should be kept to the essential minimum, and should be strictly confined to material relevant to the escalators/moving walk works and to the particular project concerned.

When enquiring for and ordering the escalators/moving walks, the particulars given below should be furnished:

- a) Type(s) of escalator/moving walk;
- b) Number of escalators/moving walks;
- c) Location of escalators/moving walks (indoor or outdoor);
- d) Capacity/usage type (persons per day/heavy duty, medium duty, light duty);
- e) Angle of inclination, in degree;
- f) Rise (travel), in m;
- g) Nominal speed, in m/s;
- h) Step width, in m;
- j) Number of flat steps (2 or 3);
- k) Balustrade details;
- m) Construction, design, finishes details;

- n) Escalator/moving walk lighting details;
- p) Electric supply: power volts a.c./d.c.; phase; cycles; wire system;
- q) Proposed date for commencement on site;
- r) Additional items, if required;
- s) Details of maintenance, schedule and circuit diagram where so specified; and
- t) Details of voice announcements, visual contrast, tactile indicators and warning signage.

11.2 Additional Items

The enquiry should state any additional items required beyond those specified in good practice [8-5B(2)], such as interface requirements, seismic design, etc.

11.3 Finishes

Finishes should be specified at the enquiry stage or provisional sums should be included for them. Finishes to be considered may include step lighting, handrail colour, handrail lighting, balustrade material, step colour, truss cladding details (weight to be considered).

11.4 Inclusions and Exclusions

A number of peripheral items are associated with escalators/moving walk installation, of which some should always be provided by the builder and some are best included by the manufacturer. The requirements vary to some extent with the type of installation.

It is important that the limits of responsibility are clearly understood, and the enquiry documents should be specific in this respect.

The escalators/moving walk manufacturer should include items, such as,

- a) tracks,
- b) drive unit,
- c) controller,
- d) broken chain,
- e) stop switches at both ends,
- f) balustrade,
- g) handrail,
- h) steps/step drive assembly,
- j) saree/skirt guard,
- k) step demarcation lights,
- m) missing steps,
- n) comb plate,
- p) flat steps,
- q) comb plate switches/skirt switches,
- r) landing steps (anti-slip material),
- s) truss,

- t) guarantee of equipment, and
- u) scaffolding for installation.

The escalators/moving walk manufacturer should exclude the supply and fixing of the items or as per the contract conditions as follows:

- 1) Hoisting hook/beam fixing,
- 2) Truss cladding,
- 3) Temporary guarding,
- 4) Cutting and making goods,
- 5) Working lights/permanent electricity supplies, and
- 6) Site painting of steel work.

For more detailed discussion of the requirements for site preparation and work by other trades, reference should be made to relevant provisions of the Code and other good practices.

Facilities for the use of the main contractor's crane should be provided to assist in installing heavy equipment in addition to other unloading facilities on site in the course of erection. The main contractor should be instructed to include these facilities in his own bill of quantities.

11.5 Site Programme

The enquiry should indicate as accurately as possible the contract programme as it affects the manufacturer, in particular the target date for completion, construction schedule, site preparedness, the availability of crane for hoisting, coordination details (with other contractors like BMS interfacing, CCTV interfacing, etc).

12 ACCEPTANCE OF TENDER AND SUBSEQUENT PROCEDURE

12.1 Order

The owner places an order with the selected contractor for supply and installation of escalator/moving walk.

12.2 The general arrangement drawings supplied by owner with the tender documents,

- a) are provided for the supplier's guidance and information when tendering;
- b) should the arrangement and dimensions shown be inadequate to properly install the equipment as specified then necessary amendments shall be issued by client; and
- c) any amendments issued after the commencement of contract shall be subject to the agreement and approval.

12.3 Layout Drawings

The contractor shall furnish proposed layout giving

particulars such as dimensions, steel work requirements and loading imposed on structure. Such drawings shall include the following details:

- a) Position and sizes of all holes and cuttings,
- b) Loads on beams and structure,
- c) Escalator/moving walk pits and associated equipment,
- d) End supports requirement including layout,
- e) Hoisting facilities and access requirement for delivery of equipment,
- f) Builder's work, and
- g) Power and ventilation requirement.

12.4 Approval of Layout Drawings

The contractor shall commence actual production of equipment after approval of drawings submitted by contractor. Where the contract provides for the purchaser's choice of decorative finishes, colours, etc, the decisions should be communicated as early as possible, and preferably not later than the time of approval of drawings.

12.5 Programme of Works

The contractor shall submit a detailed programme showing intended method and stages together with period of time estimated for each stage. The programme shall include the following:

- a) Date of commencement and completion of every stage of the works in line with the building construction programme;
- b) Date of expected completion of builder's work requirements;
- c) Date of delivery of equipment and materials to site;
- d) Date of requirement of temporary and permanent electricity supply; and
- e) Date of completion, commissioning and testing.

The contractor shall ensure the work in accordance with the criticality of adherence of installation dimensions and supports as indicated in layout.

12.6 Electricity Supply to Escalators/Moving Walk

Operation of the machine under power is required from a comparatively early stage of installation for most efficient working, and power supply shall be furnished accordingly. Whilst temporary power supply may be sufficient for erection purposes, final testing and setting up can only be carried out with the permanent power supply connected. For this reason, the timely provision of the permanent power supply is important.

13 COORDINATION OF SITE WORK

13.1 Preparatory Work on Site

13.1.1 It is expected for the escalator/moving walk supplier to make periodic visits to the site to check progress on the construction and discuss relevant matters with the owner. The contractor should assure himself that all building work has been completed in accordance with his requirements. Immediately before the time for erection to commence, the contractor should check that site conditions are fit to permit erection to proceed.

13.1.2 Building works to be completed before the erection work, includes the following:

- a) Providing adequate access to the well-way to allow for setting the equipment in place.
- b) If the project is not ready for placement at the time of delivery, providing dry storage area located close to well-way.
- c) Providing protection of all floor openings adjacent to and in the general area of escalator/moving walk.
- d) Providing safety compliant stairwell access to floors.
- e) Providing clear unobstructed workspace adjacent to well-way.
- f) Providing safety compliant overhead and floor opening protection.
- g) Providing barricades to prevent the entrance of unauthorized personnel to construction area.
- h) Drying and cleaning of pit and floor openings with proper dimensions.
- j) Providing properly located supports of adequate strength for the truss at the landings including intermediate supports, if required.
- k) Providing suitable floor fill and patching of flooring including floor covering, adjacent to the landing plates of the escalator/moving walk; all floor finishing to be completed after installation of the landing plates.
- m) Providing flooring with little slope in direction outwards of the escalator to prevent ingress of water, etc, into the escalator.

13.2 Delivery of Material

The contractor should advise the owner when equipment is ready for dispatch, so that the owner can make arrangements on site to receive and unload as near as possible to the well-way.

13.3 Storage

Adequate provision should be made by the owner for

storing, protecting and preserving against loss, deterioration of or damage to all material on the site. Attention is drawn to the adverse effect of damp conditions on electrical equipment.

13.4 Site Meetings

The contractor shall coordinate his proposed programme of work with that of the building contractor and all other contractors and sub-contractors in order to adhere to the latest overall construction programme and in order to achieve efficient and safe working on site. In large sites, regular meetings of all parties are beneficial for successful progress of work. *See also* Part 0 'Integrated Approach — Prerequisite for Applying Provisions of the Code' of the Code.

13.5 Service of Other Trades

The contractor may require the services of other trades as the work proceeds, and it is essential that the contractor should give due notice to the building contractor of the demands to be made on other trades, so that he can plan accordingly.

13.6 Connecting to Power Supply

The contractor should give prior notice to the owner of the date the power supply is required, so that suitable arrangements for connection can be made. During erection, necessary electrical power shall be provided for illumination, operation of required tools and hoist and for starting, testing and adjustment

14 INSPECTION AND ACCEPTANCE PROCEDURES

14.1 General

Escalators and moving walks shall be inspected, before their first use; after major modifications; and at regular intervals. Such inspections and tests should be made by a competent person.

14.2 Constructional Inspection and Acceptance Inspection and Test

14.2.1 The constructional inspection and acceptance inspection and test shall be carried out at the job-site on completion of the escalator or moving walk. During inspection and tests, precautions shall be taken so that escalators or moving walks cannot be set in motion without the knowledge and consent of the person(s) performing such work.

For the constructional inspection and acceptance inspection and test, the data specified in **14.4** should form part of a pre-completed test sheet. Furthermore, layout drawings, description of the equipment and wiring diagrams (current flow chart with legend or explanations, and a terminal connection chart) which

permit a check of compliance with the safety requirements, shall be provided.

The constructional inspection comprises the examination of the completed installation for conformity with the required data and with regard to proper workmanship as specified hereunder.

14.2.2 The acceptance inspection and test comprises,

- a) overall visual inspection;
- b) functional test;
- c) test of electric safety devices with regard to their effective operation; and
- d) test of the brake(s) of the escalator or moving walk under no load, for compliance with the prescribed stopping distances.

14.2.3 Stopping Distances for Escalator

The stopping distances for unloaded and downward moving loaded escalators shall be as given in Table 6.

For intermediate speeds the stopping distances shall be interpolated.

The stopping distances shall be measured from the time the electric stopping device is actuated.

NOTE — It is recommended to achieve the shortest possible stopping distance within the given deceleration limit and stopping distances for escalator.

Additionally, for escalators, a test of the stopping distances under brake load is required unless the stopping distances can be verified by other methods.

Sl No. (1)	Nominal Speed, v m/s (2)	Stopping Distance shall be Between (3)
i)	0.50	0.20 m and 1.00 m
ii)	0.65	0.30 m and 1.30 m
iii)	0.75	0.40 m and 1.50 m

14.2.4 Brake Load for Escalators

For determining the brake load for escalators, the following relation shall be used:

Nominal Width	Brake Load per Step kg
Up to 0.60 m	60
More than 0.60 m up to 0.80 m	90
More than 0.80 m up to 1.10 m	120

The number of steps to be considered is determined by 'Rise divided by maximum visible height of the step

riser'. For the purpose of a test, the total brake load is permitted to be distributed over two-thirds of the number of steps thus obtained.

14.2.5 Stopping Distances for Moving Walks

The stopping distances for unloaded and horizontally or downward moving loaded moving walks shall be as given in Table 7.

Sl No. (1)	Nominal Speed, v m/s (2)	Stopping Distance shall be Between (3)
i)	0.50	0.20 m and 1.00 m
ii)	0.65	0.30 m and 1.30 m
iii)	0.75	0.40 m and 1.50 m
iv)	0.90	0.55 m and 1.70 m

For intermediate speeds, the stopping distances shall be interpolated.

The stopping distances shall be measured from the time the electric device for stopping is actuated

NOTE — It is recommended to achieve the shortest possible stopping distance within the given deceleration limit. For moving walks, a brake test under no load is sufficient.

14.2.6 Brake Load for Moving walks

To determine the brake load for moving walks which in their length overcome several inclinations (differences in level), only the downward running sections shall be considered. For loaded moving walks, the manufacturer shall prove the stopping distances by calculation (see table).

Nominal Width	Brake Load per 0.4 m Length kg
Up to 0.60 m	50
More than 0.60 m up to 0.80 m	75
More than 0.80 m up to 1.10 m	100
More than 1.10 m up to 1.40 m	125
More than 1.40 m up to 1.65 m	150

An examination of the brake adjustment according to the calculation is required. Calculation of the stopping distances for loaded moving walks (see together with adjustment data) is also necessary.

Measurement of the insulation resistance of the different circuits between conductors and earth shall also be done. For this measurement, the electronic components shall be disconnected. This includes a test of the electric continuity of the connection between the earth terminal(s) in the driving station and the different parts of the

escalator or moving walk, liable to be live accidentally.

14.3 Inspection and Test after Major Modifications

A major modification is a change of the location, a change of the speed, of the electric safety devices, of the braking system, of the drive, of the control, of the step band, of the truss and of the balustrades. Wherever applicable, the principles set forth for the constructional inspection and acceptance inspection and test should apply to the new environmental conditions, modified components and other components which are affected.

The replacement of parts with parts of same design is not considered to be a major modification.

14.4 Specific Data, Test Reports and Certificates

The following documentation should be held by the manufacturer:

- a) Stress analysis of the truss or equivalent certificate by a competent person;
- b) Proof by calculation of sufficient breakage resistance of the parts directly driving the steps, pallets or the belt, for example, step chains, racks;
- c) Calculation of the stopping distances for loaded moving walks together with adjustment data;
- d) Test certificate for steps or pallets;

- e) Test certificate for the breaking strength of the belt;
- f) Test certificate sliding coefficients for skirting;
- g) Test certificate for anti-slip properties of tread surfaces (steps, pallets, floor and comb plates without combs);
- h) Test certificate for stopping distances and deceleration values; and
- j) Test certificate for handrail breaking strength (for public service escalators and public service passenger moving walks).

14.5 Escalator Site Checks and Inspection List

Suitable site checklist/inspection list may be used. A typical list is given at Annex A.

14.6 Escalator Commissioning and Acceptance Tests

14.6.1 Escalator Details

Typical details to be provided are given below:

- a) Name of station :
- b) Location :
- c) Escalator No. and job No. :
- d) Drawing No. :
- e) Rise :
- f) Type of balustrade : SS / Glass - Tick (✓)
- g) Manufacturer’s SI No. :

14.6.2 General Inspection

A typical general inspection list is given below:

<i>Sl No.</i>	<i>Item</i>	<i>Method/ Requirement</i>	<i>Result</i>
(1)	(2)	(3)	(4)
i)	All unwanted material have been removed	Visual check	
ii)	Escalator (including steps, handrails, floor plate, cladding, etc) has been cleaned	Visual check	
iii)	Proper barricading of the area has been done prior to testing	Visual check	
iv)	Emergency signage to be fixed at the emergency stop; safety labels placed at top/bottom newel end	Visual check	
v)	Check provision of ‘Danger Sign’ plate on the escalator control panel	Visual check	

14.6.3 Electrical Test

A typical check list of electrical tests is given below:

<i>Sl No.</i>	<i>Item</i>	<i>Test Procedure</i>	<i>Recommended Result</i>	<i>Instrument/ Sl No.</i>	<i>Measured Value</i>	<i>Result</i>
(1)	(2)	(3)	(4)	(5)	(5)	(7)
i)	Insulation resistance test	Shall be tested between lines connected together and earth at 500 V d.c.	> 0.5 MΩ (Mega Ohm)			

14.6.4 Functional Tests on Safety Switches and Devices

A typical check list is given at Annex B.

15 OPERATION AND MAINTENANCE

15.1 General

The installation shall be maintained in good working order in accordance with the installer's instructions. To this effect, regular maintenance of the installation shall be carried out to ensure, in particular, the safety of the installation. The safety of an installation shall take into account the ability to be maintained without causing injury or damage to health.

Regular maintenance of the installation shall be carried out to ensure the reliability of the installation. The access and the associated environment shall be maintained in good working order in accordance with the installer's instructions.

The instructions for maintenance of an installation shall be provided by the installer, after completion of the installation as a result of a risk assessment. The instructions for maintenance of an installation shall be provided by the manufacturer, when placed on the market, and be the result of a risk assessment.

In order that the aim of the maintenance instructions can be achieved, they shall be formulated so that they can be clearly and easily understood by competent maintenance person. The competent maintenance person within the maintenance organization shall be continuously updated.

The installer/manufacturer shall provide maintenance instructions intended for the owner of the installation (*see 15.3.2*) including the information intended for the maintenance organization (*see 15.3.3*).

NOTE — The owner of the installation should be informed that the qualification of the maintenance organization is in conformity with the regulation applicable in the location in which the installation operates.

15.2 Elements to be Taken into Account for Maintenance Instructions

When preparing the content of the maintenance instructions (*see 4.3 and 5*) the following elements shall be taken into account:

- a) Specifications and the intended use of the installation (type of installation, performance, etc);
- b) Environment in which the installation and its components are installed (weather conditions, vandalism, etc);
- c) Any restriction of use;
- d) Result of risk assessment (*see 5*) for every working area and for every task undertaken;

- e) Specific maintenance instructions provided by the manufacturer of safety components; and
- f) In case of components other than safety components, where maintenance is necessary, the maintenance instructions provided by the manufacturer of these components.

15.3 Information to be Included in the Maintenance Instructions

15.3.1 General

The maintenance instructions shall contain information relating to the tasks of both the owner and the maintenance organization, respectively.

15.3.2 Information to the Owner of the Installation

The information relating to the tasks of the owner of the installation shall include the following:

- a) Need for the owner to keep the installation in a safe operating condition. To fulfil this, the owner shall use a maintenance organization complying with the requirements of this Subsection.

NOTE — It is recommended to inform the owner of the installation about the need to use a maintenance organization with adequate and proper insurance cover provided by an insurance company.

- b) Need for the owner to take care of applicable regulation(s) and other requirements, where relevant, and their implications on maintenance.
- c) Need for planned maintenance to be carried out by a maintenance organization, at the latest when the installation is put into service or if the installation is to remain unused for a long period of time before first being put into service.
- d) Importance for the owner of the installation to have the same maintenance organization in the case of several installations having common well/spaces and/or machine room.
- e) Need for the owner to put the installation out of service in case of dangerous situations.
- f) Need for the owner of the installation to inform the maintenance organization,
 - 1) immediately about any perceived abnormal operation of the installation or abnormal change in its direct environment;
 - 2) immediately after putting the installation out of service in the case of a dangerous situation;
 - 3) after any rescue intervention by their authorized and instructed person(s);

- 4) before any modification related to the installation and/or its environment or use;
- NOTE — The owner of the installation should obtain from the company carrying out the relevant modification the maintenance instructions for the maintenance organization.
- 5) before any authorized third party inspection or works other than maintenance works are carried out on the installation;
- 6) before taking the installation out of service for a prolonged period of time; and
- 7) before putting the installation back into service after a prolonged period of non-operating time.
- g) Need for the owner of the installation to take into consideration the consequences of the risk assessment carried out by the maintenance organization.
- h) Need for the owner of the installation to make sure that the risk assessment for maintenance is carried out:
- 1) if the maintenance organization is replaced;
 - 2) if the use of the building and/or the installation changes;
 - 3) after a major modification of the installation or of the building; and
 - 4) if it is the case, after an accident involving the installation.
- j) Need for the building owner to ensure, through a risk assessment, that:
- 1) their premises are safe and free from risk to health as far as is practicable. This includes access to the premises and installation equipment, and articles or substances used according to the regulation for the use of work equipment at the workplace;
 - 2) the persons using the premises are informed about any remaining risks; and
 - 3) any action to be done as a consequence of his risk assessment is carried out.
- Regarding the access ways to areas reserved to maintenance persons, the need for the owner of the installation to inform the maintenance organization, in particular about,
- i) the access ways to be used and fire evacuating procedures from the building;
 - ii) the place where the keys of the reserved areas can be found;
 - iii) if necessary, the persons who shall accompany the maintenance persons to the installation; and
 - iv) if necessary, personal protective equipment to be used in the access ways, and, possibly, where this equipment can be found.
- The information shall be made available also on site to the maintenance organization.
- k) Need for the owner of the installation to ensure that the name and the telephone number of the maintenance organization are always available to the user of the installation, permanently affixed and clearly visible.
- m) Need for the owner of the installation to ensure that the keys of machine room doors (trap doors) and of inspection and emergency doors (trap doors), if any, are permanently available in the building and are used only by persons authorized to gain access.
- n) Need for the owner of the installation to provide, in all circumstances, safe access to the building and to the installation for the maintenance organization involved in the rescue of persons.
- p) Need for the owner of the installation to keep the access to working areas and working rooms safe and free for the maintenance persons and to inform the maintenance organization about any hazard or change in the workplace and/or the access ways (lighting, obstructions, ground conditions, etc).
- q) In addition to those examinations and tests (for escalators/moving walk) which the owner of the installation entrusts to the maintenance organization, the need for the owner to carry out periodically, in their own interests, include the following:
- 1) A full travel in both directions, when they exist, to assess any changes in the quality of the ride or damage to the equipment.
 - 2) Typical items to be checked to ensure that they are in place, undamaged and functioning correctly are,
 - i) all lighting and indicators;
 - ii) emergency stopping device;
 - iii) hand rails;
 - iv) skirting/deflector devices;
 - v) combs;
 - vi) safety signs/pictograms;
 - vii) approximation of speed between handrail and steps/pallets;
 - viii) steps/pallets;

- ix) balustrade and panels;
- x) head guard and decking;
- xi) safe and unobstructed access to entry and exit areas.

15.3.3 Information for the Maintenance Organization

The information relating to the tasks of the maintenance organization shall include the following:

- a) Need to carry out the work of maintenance in conformity with the maintenance instructions and based on systematic maintenance checks. After these checks, the maintenance organization shall decide in conformity with the maintenance instructions what is required to be done. A list of typical examples of maintenance checks to maintain the installation is shown in Annex C.

NOTE — Due to the fact that the components can be different in design and operation, it is therefore not possible to give specific guidelines in this Subsection.

- b) Need to update the original maintenance instructions, if the installation changes its intended use and/or the environmental conditions existing on the completion of the installation.

NOTE — The maintenance organization should be provided by the owner of the installation with the relevant maintenance instructions where modifications are carried out on the installation.

- c) Need for the maintenance organization to ensure that a risk assessment for any working area and for any maintenance operation has been carried out taking into account the installer's maintenance instructions and all information supplied by the owner of the installation.
- d) Need for the maintenance organization to inform the owner of the installation about any work to be carried out as a consequence of a risk assessment especially for the access and/or the environment related to the building/installation.
- e) Need to carry out a maintenance plan so that preventive maintenance is suitable for the installation and maintenance time is as short as reasonably practicable, without reducing the safety of persons, in order to minimize the non-operational time of the installation.
- f) Need to adapt the plan for maintenance so as to take account of any predictable failures, for example, those due to misuse, mishandling, deterioration, etc.
- g) Need to carry out maintenance operations by competent maintenance persons and provided with the necessary tools and equipment.

- h) Need to maintain the competency of maintenance persons.
- j) Need to carry out the maintenance periodically. In determining the frequency of maintenance interventions, the following non-exhaustive list should be considered:

- 1) Operating time and any non-operating periods of time;
- 2) Age and condition of the installation;
- 3) Location and type of building in which the installation is installed, as well as the needs of the users; and
- 4) Local environment where the installation is situated, as well as external environmental elements, for example, weather conditions (rain, heat, cold, etc) or vandalism.

- k) Need to provide a 24 h, all year round call-out service for rescue of persons.
- m) Need to keep records of the result of each intervention due to a failure of the installation. These records shall include the type of failures in order to detect any repetition. They shall be available to the owner of the installation on request.
- n) Need to put out of service the installation, if the maintenance organization is aware of a dangerous situation, detected during the maintenance, which cannot be eliminated immediately, and to inform the owner of the installation of the need to keep it out of service until repaired.
- p) Need to be organized to provide the necessary spare parts for any repair.
- q) Possible need for attendance of a competent maintenance person(s), given reasonable notice, for any inspection carried out by an authorized third party or for building maintenance works to be carried out in the areas reserved for the maintenance organization.
- r) Need to inform in due time, the owner of the installation about necessary progressive upgrading of the installation.
- s) Need to organize rescue operations, even with sub-contractor(s), and to make provision for circumstances such as fire, panic, etc.

15.4 Maintenance Contract

It is recommended that the maintenance is carried out by original equipment manufacturer (OEM). Any maintenance contract should include the following at a minimum, to ensure that escalators/moving walk is always maintained/operated in the safe working condition:

- a) All batteries used for emergency operations,
- b) All safety switches/devices,
- c) Handrail system components including handrails,
- d) Operational and auxiliary brake, and
- e) Combs.

15.5 Risk Assessment

15.5.1 General

Before an installation is placed on the market, it is necessary that the installer/manufacture carries out a risk assessment. Every risk shall be limited as much as reasonably possible by means of safety measures and suitable instructions. The instructions can never replace a safety measure which can be provided to reduce the risk.

It is necessary to determine the different intervention procedures of the maintenance operations and to determine the appropriate safety measures for each of these procedures.

The use of diagnostic systems may support fault finding, improve the maintainability of the installation and reduce the exposure of maintenance persons to hazards.

Safety in maintenance operations of the installation is ensured by adopting safety measures and providing instructions. Safety measures on the installation and in the building shall be provided by the installer and by the owner of the installation, respectively.

For any working area, it is necessary to identify the list of the specific hazards related to health and safety and to carry out a risk assessment for any maintenance operation, including access to the working area.

For this purpose, the following should be taken into account:

- a) Presence of one or more maintenance persons in a working area;
- b) Foreseeable actions of persons other than maintenance persons (for example, person switching on or off power circuits and dependent circuits or lighting circuits or trying to use the installation during maintenance operations, etc); and
- c) Possible states of the installation (normal or abnormal due to a foreseeable failure of its component parts, external disturbances, disturbance of its power supply, etc).

Annex D gives a list of examples of elements to be taken into account in any risk assessment for maintenance operations. However, several methods are available for the systematic assessment of risk.

15.5.2 Information for the Maintenance Organization

For safe maintenance and to provide relevant instructions, it is necessary, first of all, to identify the maintenance operations.

In particular, maintenance operations are,

- a) those operations considered necessary for a correct and safe functioning of the installation and its components after the completion of the installation; and
- b) those operations considered necessary during the 'life' of some components, determining, as far as possible, the time or condition after which the functioning or the integrity of the component is no longer ensured even if correctly maintained.

In carrying out specific maintenance operations, if it is necessary to neutralize some safety functions (for example, an electric safety device), the hazard identification shall be taken into account for such a situation.

It is necessary to inform and warn the maintenance persons about: (a) residual risks, that is, those for which risk reduction by design and safeguarding techniques are not there or not completely effective; and (b) risks that arise from the necessary removal of certain guards to carry out specific maintenance operations. The maintenance instructions and warnings shall prescribe the procedures and operating modes intended to overcome these risks and, if it is necessary, to specify personal protective equipment, instruments, tools and provisions to be used.

15.6 Markings, Signs, Pictograms and Written Warnings

If the risk assessment of the maintenance organization indicates that additional specific warnings are required for the purpose of maintenance, these shall be affixed directly on the installation/component or, in the close vicinity, when this is not possible. Markings, signs, pictograms and written warnings shall be readily understandable and unambiguous. Readily understandable signs and pictograms shall be used in preference to written warnings.

Signs or written warnings carrying only the words 'DANGER' shall not be used. Information affixed directly on the installation/component shall be permanent and legible.

Any markings, signs, pictograms and written warnings affixed on the installation shall be renewed if they become illegible.

15.7 Format of the Maintenance Instruction Handbook

The maintenance instruction handbook for any installation shall contain at the front at least the following:

- a) Type of installation, with its serial number, to which the instructions apply;
- b) Title of the handbook;
- c) Date of issue;
- d) Name and address of the installer/manufacturer; and
- e) Name of the publisher, when different from the installer/manufacturer.

In the handbook,

- 1) all units used shall be SI units;
- 2) all pages shall be numbered; and
- 3) all references to other documents shall be in full.

Warnings shall state the hazard, the related risks and

the appropriate safety measure.

Type and size of print shall ensure the best possible legibility. Safety warnings and/or precautions shall be emphasised through the use of colours or symbols and/or large print.

Documents giving instructions for maintenance shall be produced in durable form (that is, they shall be able to survive frequent handling) or triplicate copies shall be provided.

15.8 Maintenance Record and Annual Inspection

Maintenance organization is required to maintain a log book at the equipment to record of maintenance and repair work carried out on the equipment. In addition, the layout diagram and latest wiring diagram is required to be maintained at the equipment by maintenance organization. Maintenance organization is required to carry out annual inspection of the installation and certify that escalator is in safe for operation. Owner of the installation is responsible for ensuring that any deficiencies found during the annual inspection are rectified before the equipment is put back in service.

ANNEX A
(Clause 14.5)

TYPICAL ESCALATOR SITE CHECKLIST/INSPECTION LIST

Sl No.	Items	Frequency and Method	Requirement	Value Required	Value Measured	Result
(1)	(2)	(3)	(4)	(5)	(6)	(7)
i)	Definition of datum and installation of bearing plate	100 percent (Visual check)	Check whether metal plate and isolation rubber pad provided at both top and bottom escalator support notches	YES/NO		
ii)	Intermediate support	100 percent (Visual check)	Check whether both support points are loaded by ensuring: a) Tightness of bolts and locking of check-nut b) Check for any sag by holding a thread from the nose of top-most step to the nose of bottom-most step (excluding flat steps)	YES/NO YES/NO		
iii)	Alignment of truss and end supports	100 percent (Visual check)	Check horizontal level using spirit-level on step: a) Top support b) Bottom support c) Middle level	OK/NOT OK OK/NOT OK OK/NOT OK		
iv)	Alignment of drive top/reverse/bottom/tension carriage	Random (Visual check)	Alignment : Factory setting Check tightness of nuts and bolts	OK/NOT OK OK/NOT OK		
v)	Alignment of track brackets	Random (Visual check)	Alignment : Factory setting Check tightness of nuts and bolts	OK/NOT OK OK/NOT OK		
vi)	Alignment of inclined tracks	Random (Visual check)	Alignment : Factory setting	OK/NOT OK		

ANNEX A — (Continued)

Sl No.	Items	Frequency and Method	Requirement	Value Required	Value Measured	Result
(1)	(2)	(3)	(4)	(5)	(6)	(7)
			Check tightness of nuts and bolts	OK/NOT OK		
vii)	Installation and alignment of upper and lower newel wheels	Random (Visual check)	Alignment : Factory setting	OK/NOT OK		
			Check tightness of nuts and bolts	OK/NOT OK		
viii)	Alignment of skirting brackets and panels	Randomly at number of locations (Measure using taper gauge/tape)	a) Clearance between comb plate and skirt b) Distance between skirt panel c) Clearance between skirt and step d) Levelness of skirt joint e) Clearance of skirt joint	2 mm, <i>Max</i> (1 000 + 7) mm One side 4 mm, both sides total 7 mm 0.5 mm, <i>Max</i> 0.5 mm, <i>Max</i>		
ix)	Installation of step chain and steps	Randomly at number of locations (Visual check)	a) Visual check chain joint — Step chain joint link plate fixed properly b) Step assembly (random check 10 pieces) — Circlip of step chain is properly secured in its position c) No step transverse movement (random check 10 pieces) d) Colour on Step, As per specifications	OK/NOT OK OK/NOT OK OK/NOT OK YES/NO		
x)	Installation of balustrade steelworks	Randomly at number of locations (Visual check and by using spanner/screw driver)	Check tightness of nuts and bolts	OK/NOT OK		

ANNEX A — (Continued)

Sl No.	Items	Frequency and Method	Requirement	Value Required	Value Measured	Result
(1)	(2)	(3)	(4)	(5)	(6)	(7)
xi)	Glass balustrade	100 percent (Measure using tapper gauge/visual check)	a) Gap between the glass panels	4 mm OK/NOT OK		
			b) Provision of rubber pad between the glass	YES/NO		
xii)	Stainless steel balustrade	100 percent (Measure using feeler gauge)	a) Gap between the panel (inner)	OK/NOT OK		
			b) Visual check the outer cladding	OK/NOT OK		
xiii)	Alignment of handrail tracks	Randomly at number of locations (By feeling the edges at joints)	Handrail guide joints fitted without sharp edges	OK/NOT OK		
xiv)	Installation of top decking panels, inner panels, skirting returns and kick plates	100 percent (Visual check)	Check whether all decking and skirt panels are provided properly	OK/NOT OK		
xv)	Installation of upper and lower comb plates and access floor covers	100 percent (Visual check)	Check whether comb plates and floor plates are provided properly	OK/NOT OK		
xvi)	Floor plate	100 percent (Visual check/tape/stainless steel ruler)	a) No tripping hazard on floor plate	YES/NO		
			b) Clearance between floor plate and frame	2 mm, <i>Max.</i> YES/NO		
			c) Clearance between comb plate and floor plate	6-8 mm YES/NO		
xvii)	Alignment of main drive chain, handrail drive chains	100 percent (Tape/stainless steel ruler)	Sagging of handrail drive chain	10-20 mm YES/NO		
			Sagging of drive chain	10-20 mm YES/NO		
xviii)	Alignment of 'over speed / under speed' detection unit drive chain	100 percent (Visual check)	Check whether the 'over speed' 'under speed' sensor is provided	YES/NO		

ANNEX A — (Concluded)

Sl No.	Items	Frequency and Method	Requirement	Value Required	Value Measured	Result
(1)	(2)	(3)	(4)	(5)	(6)	(7)
xix)	Cables are properly laid in raceway and properly dressed. The power and control wiring is done properly with ferruling and identification tags	100 percent (Visual check)	Check provision of proper arranged cable tray (or) flexible hose	YES/NO		
			Check provision of labels/ ferruling	YES/NO		
			Check for proper dressing of cables	YES/NO		
xx)	Installation of switches and wiring	100 percent (Visual check)	Safety switches and limits switches and its location fixing arrangement to be checked	YES/NO		
xxi)	Installation of lubrication system	100 percent (Visual check)	Check whether automatic lubrication system is provided	YES/NO/NA		
xxii)	Earthing has been extended to all relevant locations	100 percent (Visual check)	Check tightness of earthing strips/wires	YES/NO		
xxiii)	Installation of controller	100 percent (Visual check)	Check, if controller is fixed properly (for tightness, straightness)	YES/NO		
xxiv)	Installation of escalator cladding and decking	100 percent (Visual check)	Check whether cladding and decking have been provided properly	YES/NO		
xxv)	Others: Over lapped type joints of drip pan	100 percent (Visual check)		YES/NO		
xxvi)	The clear height above the steps	Measuring tape	At all points shall be not less than 2.30 m	YES/NO		

ANNEX B
(Clause 14.6.4)

TYPICAL CHECK LIST FOR FUNCTIONAL TESTS ON SAFETY SWITCHES AND DEVICES

Sl No.	Check Point	Method	Value Required	Measured Value	Result
(1)	(2)	(3)	(4)	(5)	(6)
i)	The over speed protection devices	Tripping the over speed device manually	OK/NOT OK		
ii)	The handrail tension malfunction devices/broken handrail monitor	Test operation of handrail tension/broken handrail switch	OK/NOT OK	Left: Right:	
iii)	The broken drive chain protection	Tripping the broken drive chain device manually by hand	OK/NOT OK		
iv)	Broken step chain monitor	Tripping the broken step chain device manually under the step chain spring at 2 locations in the bottom pit	OK/NOT OK	Left: Right:	
v)	Emergency stop switch	Push the button	OK/NOT OK	Top: Intermediate level: Bottom:	
vi)	Direction key switch (Start switch)		OK/NOT OK	Top: Bottom:	
vii)	Traffic bollard		OK/NOT OK		
viii)	Traffic light working	Check for correct movement indication (Up/Down) visual check	OK/NOT OK	Top: Bottom:	
ix)	Provision of comb light	Visual check	OK/NOT OK		
x)	Phase failure/Phase reversal protection	Visual check simulate the function device	OK/NOT OK		
xi)	Hand rail inlet monitor	In the handrail inlet at 4 locations; trip manually	OK/NOT OK	Bottom Left: Bottom Right: Top Right: Top Left:	
xii)	Skirt panel deflection safety switch	Trip manually	OK/NOT OK	Bottom Left: Bottom Right: Top Right: Top Left:	
xiii)	Step sag monitor	Trip manually	OK/NOT OK	Top: Bottom:	
xiv)	Comb plate safety device	Trip manually	OK/NOT OK	Top Left: Top Right: Bottom Left:	

ANNEX B — (Concluded)

Sl No.	Check Point	Method	Value Required	Measured Value	Result
(1)	(2)	(3)	(4)	(5)	(6)
xv)	Floor plate open switch	Open floor plate- manually	OK/NOT OK	Bottom Right:	
			OK/NOT OK	Top:	
			OK/NOT OK	Bottom:	
xvi)	Step missing monitor	Simulate function of sensor - manually	OK/NOT OK	Top:	
			OK/NOT OK	Bottom:	
xvii)	Float safety switch	Trip manually	OK/NOT OK		
xviii)	Handrail speed monitor	Simulate change in speed manually	OK/NOT OK	Left:	
			OK/NOT OK	Right:	
xix)	Step up-thrust monitor	Trip manually	OK/NOT OK	Top:	
			OK/NOT OK	Bottom:	
xx)	Brake open detect switch	Trip manually	OK/NOT OK	Left:	
			OK/NOT OK	Right:	
xxi)	Provision to measure the braking distance	Visual check, provision of sensor/encoder	Yes/No		
xxii)	Sprinkler:				
	a) Connected to main system		Yes/No/NA		
	b) Number of sprinkler heads provided		Yes/No/NA		
xxiii)	Hand winding unit (Check for proper operation)	Escalators should move easily in downward direction	Yes/No		
xxiv)	Details of gear box:				
	a) Gear box make				
	b) SI No.				
	c) Reduction ratio				
	d) Check gear oil level				
xxv)	Details of motor:				
	a) Manufacturer				
	b) Motor SI No.				
	c) kW Rating				
	d) Current rating				
	e) RPM				
	f) Insulation class				

ANNEX C[(*Clause 15.3.3(a)*)]**TYPICAL EXAMPLES OF MAINTENANCE CHECKS TO MAINTAIN THE INSTALLATION****C-1 ESCALATORS AND MOVING WALKS**

Sl No.	Component	Checks
(1)	(2)	(3)
i)	Controller	Check cabinet is clean, dry and free from dust
ii)	Gear box	Check gear and associated parts Check lubrication
iii)	Drive motor	Check bearings for wear Check lubrication
iv)	Brake	Check braking system Check parts for wear
v)	Auxiliary brake	Check braking system Check parts for wear
vi)	Intermediate gear box	Check gear and associated parts Check lubrication
vii)	Main drive chain	Check for tension and wear Check lubrication
viii)	Step/pallet chain	Check for tension and wear Check lubrication
ix)	Step/pallet	Check step/pallet and step/pallet wheels for integrity
x)	Conveyor belt	Check for condition and tension
xi)	Drive belt	Check for condition and tension
xii)	Clearances	Check step to step and step to skirting clearances
xiii)	Combs	Check condition Check meshing with steps, pallets or belt
xiv)	Comb plate	Check clearances and operation
xv)	Handrails	Check for free running and condition Check tension Check synchronization between step/pallet band and the handrail
xvi)	Track system	Check for condition and wear Check fixings
xvii)	Safety devices	Check operation
xviii)	Deflector devices	Check condition
xix)	Lighting	Check operation
xx)	Display	Check operation
xxi)	Signs/pictograms	Check condition
xxii)	Balustrade	Check condition of panels Check fixings of interior claddings

ANNEX D
(Clause 15.5.1)

EXAMPLES OF ELEMENTS TO BE TAKEN INTO ACCOUNT IN ANY RISK ASSESSMENT FOR MAINTENANCE OPERATIONS

D-1 ESCALATORS/MOVING WALKS

Elements	Machinery Spaces	On Step/Pallet Band	Inside Step/Pallet Band	Upper and Lower Landing	Control Cabinet	Machine Room (External Drives)
Access and entry	R	R	R	R	R	R
Inadequate lighting (including access)	R	R	R	R	R	R
Falls/slips	R	R	R	R	R	R
Falling on machine	NR	R	NR	R	NR	NR
Falling over balustrade	NR	R	NR	R	NR	NR
Contact with moving machinery	R	R	R	R	R	R
Indirect contact with machinery	R	R	R	R	R	R
Crushing and shearing (step to step or comb/step to skirting)	R	R	R	NR	NR	NR
Gaps in balustrade	NR	R	NR	NR	NR	NR
Intersection between floors and/or escalators	NR	R	NR	NR	NR	NR
Persons on the step band	NR	R	NR	R	NR	NR
Safety switches and emergency stopping device(s)	R	R	R	R	R	R
Inspection control	R	R	R	R	R	R
Intersection between fixed and moving parts	NR	R	NR	NR	NR	NR
Unintentional start/stop	R	R	R	R	R	R
Machine moving (other than on power)	R	R	R	R	R	R
More than one maintenance person working	R	R	R	R	R	R
Manual operation	R	NR	R	R	R	R
Falling objects	R	R	R	R	NR	R
Unexpected water/dirt	R	R	R	R	R	R
Contamination by oil and grease	R	R	R	R	NR	R
Dangerous substances	R	R	R	R	R	R
Fire	R	NR	R	NR	R	R
Missing step/pallet	R	R	R	R	NR	NR

‘R’ = Relevant and ‘NR’ = Not relevant

LIST OF STANDARDS

The following list records those standards which are acceptable as 'good practice' and 'accepted standards' in the fulfilment of the requirements of the Code. The latest version of a standard shall be adopted at the time of enforcement of the Code. The standards listed may be used by the Authority for conformance with the requirements of the referred clauses in the Code.

In the following list, the number appearing in the first column within parentheses indicates the number of reference in this Subsection.

<i>IS No.</i>	<i>Title</i>
(1) 732 : 1989	Code of practice for electrical wiring installation
3043 : 1987	Code of practice for earthing
(2) 4591 : 1968	Code of practice for installation and maintenance of escalators

NATIONAL BUILDING CODE OF INDIA

PART 8 BUILDING SERVICES

Section 6 Information and Communication Enabled Installations

BUREAU OF INDIAN STANDARDS

CONTENTS

FOREWORD	...	3
1 SCOPE	...	5
2 TERMINOLOGY	...	5
3 GENERAL REQUIREMENTS FOR TELECOMMUNICATION SPACES AND CONNECTING HARDWARE	...	7
4 SPECIFIC REQUIREMENTS FOR TELECOM INFRASTRUCTURE CABLING	...	21
5 OTHER APPLICATIONS IN TELECOM INFRASTRUCTURE CABLING	...	24
ANNEX A ADDITIONAL GUIDELINES FOR INFORMATION AND COMMUNICATION ENABLED INSTALLATIONS	...	24
LIST OF STANDARDS	...	28

FOREWORD

This Code (Part 8/Section 6) covers the essential requirements for information and communication enabled installations, technology systems and cabling installations in a building. It also covers the basic design and integration requirements for telecommunication spaces within building/buildings along with their cabling infrastructure, their pathway components and passive connectivity hardware. It also includes general requirements relating to installation of different communication equipment, cable terminations, power connections and general guidelines required for planning and providing information and communication technology (ICT) services in the building at the planning and execution stages. The provisions given herein are basic requirements applicable to all residential and other buildings. These can be used at the time of upgradation of existing buildings for properly accommodating telecom systems/services. Buildings meant for data centres and those for housing telecom exchanges/facilities for offering public services may have various other considerations. For such buildings, provisions of this Section are indicative and may be a subject of actual requirements.

Telecommunication plays a vital role in modern society similar to electricity, water and transport systems. It is difficult to imagine a life without telecommunication technologies. In a building, a broad variety of telecommunication systems are expected to be installed. Buildings have provision for installation of various utilities. However, unlike traditional utilities, telecommunication systems are constantly evolving at a rapid pace.

Telecommunications connectivity can be delivered through cable, wire, optical fibre, fixed wireless and mobile wireless technologies. Each of these technologies when considered for use inside buildings, especially when the buildings are either commercial or multi-dwelling units or complexes, places its own requirement in terms of building space, power supply, internal extensions to various work areas/dwelling units. For example, for wire line services, broadband cable television, etc, the entry to the buildings/complexes will be through underground cables and the distribution of services further into the complexes will be from the bottom of the building to the upper stories. On the contrary, any wireless technologies, where antennas are to be installed at terrace along with a system which can distribute the signals through cables, the flow of cables will be from top storeys of the building to the bottom. It is also to be kept in view that there are multiple service providers for each type of service with similar or different technologies.

The telecom facilities can be chosen by the user from the gamut of technologies and associated features as options are available based on the requirement, cost, service and maintenance convenience, future upgradation requirements, etc. While providing telecom enabling infrastructure in the building, the provisions are to be made for making the infrastructure supportive for multiple technologies/products and the requirements of telecom service providers. Use of Building Management System (BMS) and creation of 'Smart' building will require significant telecom infrastructure to be created within the buildings. This may be supported by machine to machine (M2M) communication technologies. Individual/tenant users of the building may also have their own M2M/IoT systems with wireline or wireless gateways. The telecom support infrastructure in the buildings/campuses needs to be responsive and accommodative of these requirements.

In order to facilitate installation/upgradation of telecom systems, proper planning and understanding of enabling provisions for telecom technologies and physical infrastructure are necessary. Modern telecommunication technologies such as Distributed Antenna System, Wi-Fi and other in-building solutions are also to be considered during the building planning stage itself. The enabling infrastructure may include cable riser systems, conduits, cable trays, etc. Appropriate space need to be earmarked for installation of equipment at the entry point of service and running the cables, etc, through shafts and horizontal conduits inside the walls, centre of the corridors and centre of the work space, etc. Thus, cabling pathways infrastructure should be designed to be of general nature but flexible enough to accommodate a variety of telecom systems and emerging technologies.

Choice of service to be provided inside the complexes/buildings will depend on the users. As already mentioned above, the delivery of service can be spread across technologies and across various service providers. Therefore,

the arrangement for telecommunication infrastructure needs to be made in such a manner that the requirements and the challenges of at least near future can be met without disturbing the building infrastructure. This Section has been formulated to cover these aspects.

In the formulation of this Section, due weightage has been given to international coordination among the standards and practices prevailing in different countries, in addition to relating it to the practices in this field in this country. This has been done by deriving assistance from the publications of ISO, IEC, ITU, etc.

For the purpose of deciding whether a particular requirement of this Section is complied with, the final value, observed or calculated, expressing the result of a test or analysis, shall be rounded off in accordance with IS 2 : 1960 'Rules for rounding off numerical values (*revised*)'. The number of significant places retained in the rounded off value should be the same as that of the specified value in this Section.

NATIONAL BUILDING CODE OF INDIA

PART 8 BUILDING SERVICES

Section 6 Information and Communication Enabled Installations

1 SCOPE

1.1 This Code (Part 8/Section 6) covers the essential requirements for information and communication enabled installations, technology systems and cabling installations in a building. It also covers the basic design and integration requirements for telecommunication spaces within building/buildings along with their cabling infrastructure, their pathway components and passive connectivity hardware.

1.2 It also includes general requirements relating to installation of different communication equipment, cable terminations, power connections and general guidelines required for planning and providing information and communication technology (ICT) services in the building at the planning and execution stages. The provisions given herein are basic requirements applicable to all residential and other buildings. These can be used at the time of upgradation of existing buildings for properly accommodating telecom systems/services. Buildings meant for data centres and those for housing telecom exchanges/facilities for offering public services may have various other considerations. For such buildings, provisions of this Section are indicative and may be a subject of actual requirements.

NOTE — In this Section, ‘Telecom’ has been used interchangeably with ‘ICT’, as most of the time there may be only telecommunication hardware present. Apart from the provision of telecommunication systems, Information Technology (IT) system in the building may be either common for the building or separate for the individual users. In case the entire building is used by the same user, the IT system may be common and thus IT space for Building Management System (BMS), CCTV, etc, can be shared with telecom facilities. In case where individual IT systems owned by several users are provided, separate spaces may be earmarked inside telecom spaces for individual IT infrastructure. Sometimes, individual users may also use the common IT facilities. However, the cabling, wiring, etc, for IT systems should use the same pathways, which are used for telecommunication hardware.

2 TERMINOLOGY

For the purpose of this Section, the following definitions shall apply.

2.1 Access Point — A hardware device or a computer’s software that acts as a communication hub or as an interconnection port for users of wireless devices to connect them to a wired or wireless local area network (LAN).

2.2 Antenna — An electrical device designed to transmit or receive radio waves or more generally,

electromagnetic waves for the purpose of radio frequency communication such as Wi-Fi, radio, television, satellite communication, radar communication and mobile communication. This is also called an aerial.

2.3 Attenuation — A general term that refers to any reduction in the strength of an electrical/electromagnetic signal.

2.4 Backbone — A high-capacity facility (for example, pathway, cable or conductors) which acts as a major pathway within a network from which further smaller capacity facilities get distributed.

2.5 Backbone Cabling Media Distribution and Building Pathway — A part of a building premises telecom cable distribution system that provides connection between telecommunications spaces. It typically provides building connections between floors in multi-storeyed buildings as well as campus connections in multi-building environments.

2.6 Building Management System — It is a low voltage automation or remote control system installed for managing different building sub-systems like, heating, ventilation, lighting, air conditioning, fire protection, access control, etc.

2.7 Bus Bar — It refers to thick strips of copper or aluminium, in electrical power distribution that conduct electricity within a switchboard, distribution board, substation, or other electrical apparatus.

2.8 Coaxial Cable — A type of wire that consists of a centre wire surrounded by insulation and then a grounded shield of braided wire. The shield minimizes electrical and radio frequency interference.

2.9 Consolidation Point (CP) — A location for interconnection between horizontal cables extending from building pathways and horizontal cables extending into furniture pathways.

2.10 Cross-Connect — A facility enabling the termination of cable elements and their interconnection or cross-connection.

2.11 Direct to Home (DTH) — The direct reception of satellite programs using small dish (personal dish) placed on a roof or window of a house.

2.12 Frequency — The measurement of the number of times that a repeated event occurs per unit of time.

2.13 Horizontal Cabling — It includes, (a) the cabling

between and including the telecommunications outlet/connector and the horizontal cross-connect, and (b) the cabling between and including the building management system outlet or the first mechanical termination of the horizontal connection point and the horizontal cross-connect.

2.14 Horizontal Cabling Media Distribution and Building Pathway — It consists of the horizontal cabling in the building, the horizontal pathways supporting the horizontal cabling, and the telecommunications spaces that support the horizontal pathways. The use of the term horizontal in the name of the element does not require that the elements be placed or installed parallel to the ground or floor.

2.15 Horizontal Cross-Connect (HC) — A cross-connect of horizontal cabling to other cabling, for example, horizontal, backbone, and equipment.

2.16 Inside Plant (ISP) — Telecommunications infrastructure designed for installation, interior to the buildings.

2.17 Intermediate Cross-Connect (IC) — A cross-connect between first level and second level backbone cabling. First level backbone is a cable between a main cross-connect (MC) and intermediate cross-connect (IC) or horizontal cross-connect (HC). Second level backbone exists between an intermediate cross-connect (IC) and horizontal cross-connect (HC).

2.18 Internet of Things (IoT) — A network of all physical objects connected to internet primarily using M2M communication technologies.

2.19 Local Multipoint Distribution System (LMDS) — A broadband radio service designed to provide two-way transmission of voice, high-speed data and video (wireless cable TV) digitally through microwave.

2.20 Local Area Network (LAN) — A computer network covering a local area, like a home, office or small group of buildings.

2.21 Machine to Machine (M2M) Communication — It is a set of wired/wireless communication technologies which enable machine/device (for example sensor, meter, etc) to capture an event (for example temperature, motion, meter reading, etc) and relay through communication network to an application that translates the data from device to a meaningful information.

2.22 Main Cross-Connect (MC) — A cross-connect for first level backbone cables, entrance cables, and equipment cables.

2.23 Main Distribution Frame (MDF) — A structure where all the copper wires, fibre or coaxial cables for a

network terminates for patching/cross-connection on separate or composite frames.

2.24 Metropolitan Area Network (MAN) — A network designed to carry data over an area larger than a campus, such as an entire city and its outlying area.

2.25 Multichannel Multipoint Distribution System (MMDS) — A method of delivering multiple voice/data/television signals digitally by microwave transmission to subscriber households.

2.26 Multi-User Telecommunications Outlet Assembly (MUTOA) — A grouping in one location of several telecommunications outlet/connectors.

2.27 Optical Fibre — It refers to the medium and the technology associated with the transmission of signals/information as light pulses along a glass fibre.

2.28 Optical Distribution Frame (ODF) — Optical fibre distribution frame where ends of optical fibre terminates for further patching/cross-connection.

2.29 Outside Plant (OSP) — Telecommunications infrastructure designed for installation, exterior to the buildings.

2.30 Propagation Delay — In a communications system, it refers to the time lag between the departure of a signal from the source and the arrival of the signal at the destination.

2.31 Public Mobile Network — A network that is established and operated by a telecom service provider for the specific purpose of providing mobile telecommunications services to the public using technologies such as GSM, CDMA and LTE.

2.32 Radio Frequency — A frequency range from 20 kHz and above, used for transmitting/receiving text, data, audio, or video signals.

2.33 Server — Any computer on a network that contains data or applications shared by users of the network on their client terminals.

2.34 Splicing — The process of permanent joining of bare fibre end to another fibre by means of splicing tools.

2.35 Smart City/Building/Home — An innovative city/building/home that uses information and communication technologies, and other means to improve quality of life, efficiency of operation and services and competitiveness, while ensuring that it meets the needs of present and future generations with respect to economic, social and environmental aspects.

2.36 Telecommunication Spaces — The rooms and areas where telecommunications cabling systems are terminated, cross-connected and interconnected to installed telecommunications equipment. Various examples of these

based on the function and areas, are equipment room (ER), telecommunications room (TR), entrance facilities (EF) and telecommunication enclosures (TE).

NOTE — The definitions of telecommunication spaces and workspace (*see* 2.44) are used for calculation of infrastructure requirements, facilities, etc. This does not inhibit the utilization of space for any other purpose. Depending upon the requirements, number of telecommunication spaces in a given building may vary for the same area.

2.37 Telecom Service Provider (TSP) — A service provider who is authorized to operate telecom services by Government of India. It includes telecom Infrastructure Providers (IPs) also.

2.38 Telecom Tower — A vertical structure for installation of antenna(e) that provide radio frequency air interface for telecommunications services. It can also be in the form of mast or multiple poles of varying height. Poles may be located at different points typically on the roof.

2.39 Telecommunication Media and Connecting Hardware — It consists of cables, equipment cords, patch cords, and connecting hardware components. All balanced twisted-pair, optical fibre, coaxial cabling and wireless systems are made up of such components. These cabling components and resulting cabling systems are used in outside plant (OSP) and premises cabling [also known as inside plant (ISP)] environments of the building telecommunication infrastructure.

2.40 Underground Cable Vault (UCV) — An underground cable vault (part of an underground duct system) used to facilitate placing, connecting, and maintaining telecommunications cables and associated equipment. It collectively refers to manholes, hand holes, and pull holes.

2.41 Very Small Aperture Terminal (VSAT) — It usually refers to satellite terminal used to transmit and receive signal from satellites with an antenna installed in user premises.

2.42 Wide Area Network (WAN) — It is a network that is capable of spanning a geographical area larger than a city.

2.43 Workstation — An electronic device that performs some information processing or display function and connects to the communications network. Typically, this may be a desktop computer with keyboard and display or laptop computer, but might also be a telephone, a printer, an access control terminal, or some data-gathering device.

2.44 Workspace — Any location and the space around where a workstation may be located. Typically there can be several workspaces in a room.

3 GENERAL REQUIREMENTS FOR TELECOMMUNICATION SPACES AND CONNECTING HARDWARE

3.1 Telecommunication Spaces

3.1.1 General Considerations

The following shall be the considerations for telecommunication spaces:

- a) *Accessibility* — Telecom spaces that are intended to serve multiple users should be located in common spaces that should be accessible through a common corridor or outside door. The space for each telecom service providers may be separated to the extent feasible by partitions for security reason and controlled access to their equipment. The telecommunication spaces should be accessible, but the access should be controlled against the unauthorized access (for example, with a lock and key arrangement or by an electronic access system).
- b) *Acoustic noise levels* — Acoustic noise levels in telecom spaces should be kept to a minimum by not collocating noise-generating equipment (for example, photocopy equipment, high-speed printers, and mechanical equipment).
- c) *Administration* — All pertinent documentation of deployment of telecom equipment and cables should be maintained by owner or agent when the installation is completed. All telecom spaces shall have appropriate signs to identify the space and should be included within the security plan of the building.
- d) *Cable separation* — Telecom cables should be separated from possible sources of electromagnetic interference (EMI) and from possible radio frequency interference (RFI). For safety purposes, power cables should be separated from telecom cables.
- e) *Ceilings* — The general requirements for ceilings in telecom spaces should include the following:
 - 1) Generally, the minimum ceiling height shall be 2.4 m above finished floor. However, consideration may be given for having a 3 m ceiling height.
 - 2) If suspended ceilings are provided, necessary rodent protection may be provided.
 - 3) The ceiling finish should minimize dust and be light coloured to enhance the room lighting.

- f) *Conduits, trays, slots, sleeves and ducts* — Slot/sleeve systems should be located in places where pulling and termination of cables is easy to achieve. Bend radius requirements and service loop guidelines shall be considered. Sleeves and slots shall not be left open after cable installation. All sleeves and slots shall be fire-stopped in accordance with Part 4 ‘Fire and Life Safety’ of the Code.

The size and number of conduits or sleeves used for backbone pathways depends on the usable floor space served by the backbone distribution system. However, sleeves in multiple of 100 mm are recommended to serve a TR, ER or EF. Multiple telecom spaces on the same floor shall be interconnected with a minimum of one 75 mm conduit or a pathway that provides equivalent capacity.

- g) *Dust and static electricity* — Dust and static electricity should be avoided by,
- 1) placing active printers outside of telecom spaces, and
 - 2) treating floors, walls, and ceiling to minimize dust.
- h) *Electrical power* — When active equipment of TSPs or the building equipment (for example, PABX) are installed in TR/ER, etc, the telecom spaces shall be equipped to provide adequate electrical power. The recommendations are as under:
- 1) A diesel generator (DG) set may be considered if longer power interruptions are expected for which the battery backup is not adequate. Further, as telecom services are required on 24x7 basis, uninterrupted electrical power for telecom services shall be provided from local or central uninterrupted power supply (UPS) with adequate battery backup. One of the option is that individual TSP provide their own UPS. However, this may not be space and energy efficient. Further, UPS arrangement may be extended to equipment in TE/corridors also.
 - 2) Separate socket outlets for equipment, tools, test instruments, etc.
 - 3) Separate electrical distribution panels that serve telecom equipment/spaces from those that serve other purposes are recommended. These should be clearly identified with proper sign writing.
- j) *Prevention from flooding* — Telecom spaces should be located above any threat of flooding.

When locating telecom spaces where a threat of flooding is unavoidable, rack elevations may be designed so that active equipment and telecom components are placed above the threat level. Sometimes locating the ER/TR on a floor above ground floor may be safer. The locations that are below or adjacent to areas of potential water hazard (for example, restrooms, kitchens) should be avoided. Liquid carrying pipes (for example, water, waste, steam) should not be routed through, above, or in the walls encompassing the ICTs space. If due to unavoidable circumstances, liquid carrying pipes are passing through telecom spaces then these spaces may be preferably monitored for water seepage by deploying suitable water seepage detection system. Otherwise, regular watch may be kept to detect seepage.

When air conditioning ducts are installed in telecom spaces, water dripping/leaking from AC vent should be controlled and, if required, monitored by water leaking system. Instructions for prevention from liquid cleaning agents, air purifying liquids, pest repellants and sprays usage should be indicated by proper sign writing.

- k) *Lighting* — Following are the important considerations for lighting of telecom spaces:
- 1) Locating light switches near the entrance(s) to the telecom space.
 - 2) Coordinating the lighting layout with the planned equipment layout (especially overhead cable trays) to ensure that lighting is not obstructed.
 - 3) Providing electrical power for the lighting and ICT equipment from different circuits.
 - 4) Placing at least one light or set of lights on normal power and one light or set of lights on emergency/UPS power.
 - 5) Using a light coloured finish on walls, floors, and cabinets to enhance room lighting.
 - 6) Providing task lighting illumination at the point of cable termination.
 - 7) Providing adequate lighting of spaces, which may be controlled by automated controllers such as Building Management System (BMS), if required, or ensured otherwise. Use of dimmers and occupancy sensors is not recommended.
- m) *Location* — All telecom spaces shall be located in areas that are best suited to serve

the occupants of a floor or building. The following shall be observed when locating the spaces:

- 1) Telecom spaces in multi-floor buildings should be aligned vertically.
 - 2) Telecom spaces should be located in areas that are dedicated to telecom use. Equipment that is not related to the support of telecom spaces (for example, piping, duct work, distribution of building power) shall not be located in or pass through a telecom space.
- n) *Environmental control* — When active devices which are heat producing equipment are present, original equipment manufacturer (OEM) recommended temperature and humidity range should be maintained by adequate arrangement for heat dissipation. If environmental parameters are exceeded, an alarm should be activated. A positive pressure is required to be maintained with a minimum of one air change per hour in the telecom space. More stringent requirements may apply based on the equipment needs in the telecom space.
- p) *Fire protection* — The telecom spaces shall be equipped with adequate fire detection, alarm and suppression systems as per Part 4 ‘Fire and Life Safety’ of the Code.
- q) *Bonding and grounding* — All equipment and cable shields shall be properly bonded to the telecom bonding and grounding infrastructure of the space (see 4.1 for details).

3.1.2 Equipment Room (ER)

3.1.2.1 An equipment room is an environmentally controlled centralized space for telecom equipment that usually house equipment of higher complexity than telecommunication rooms and also usually houses a main or intermediate cross-connect. Any or all of the functions of a telecommunications room may be provided in an equipment room. ERs differ from TRs in the way, that, ERs are generally considered to serve a building, campus, tenant, or SP, whereas TRs serve a floor area of a building. In some cases, an ER may also contain the EF or it may serve as TR. ERs may be connected to backbone pathways that run both within and between buildings. Although an ER usually serves an entire building, many building designs may use more than one ER in order to provide separate facilities for different types of equipment and services or redundant facilities and disaster recovery strategies.

The initial assessment for design and specifications for an ER shall be based on detailed information about the site, including,

- a) user requirements;

- b) telecom pathway locations;
- c) service provider’s requirements;
- d) environment/facility conditions; and
- e) building requirements.

3.1.2.2 Space allocation and layout

The space allocation and layout may be determined by following methods:

- a) *Determining size based on area served* — When the telecom designer does not know what specific equipment will be used in an ER, the designer can use the amount of floor space that the room will serve, to determine the minimum size of the ER. If the usable floor space is also unknown, the usable floor space may be estimated by deducting 20 percent from the total floor area.

Generally, an area of 9.3 m² may be considered for calculating the work areas. If work areas are smaller leading to possible increase in number of work areas in building, the size of the ER should be increased accordingly. The minimum recommended size for ER is 14 m². The general practice is to provide 0.07 m² of ER space for every 10 m² of usable floor space. For special use buildings, such as, hospitals and hotels, ER size requirements may vary.

- b) *Telecom service provider space requirements* — If equipment or cable terminations that are owned or maintained by a TSP are to be located in the ER, then location and amount of space required shall be determined as per the space requirement of TSP.
- c) *Telecom equipment locations* — As equipment for communication systems are located in the various equipment rooms throughout the building, these rooms shall be physically secure, aesthetically provisioned and conveniently located. The communication equipment may be located with due consideration of the modular provision of building design and criteria for expansion joints matching to electrical distribution and maximum fire safety distance requirements. The other considerations for telecom equipment location include the following aspects:
 - 1) Types of cables, their uses, bending radius, turning radius, conduit radius, etc.
 - 2) *Provision for future expansion* — In view of the evolving nature of the communication technologies, provision for future expansion should be ensured by way of stand-by arrangements. The distribution infrastructure should also be as flexible

as possible. Small conduits will quickly fill up and may not accommodate some technologies, for example, low loss broadband or high capacity fibre optic cables. The most flexible distribution design involves cable trays for horizontal (floor level) distribution with large conduit sleeves for wall penetration, where necessary. Vertical trunk distribution should also be achieved with conduit sleeves.

- 3) **Maintainability** — As it is difficult to remove or shift just a few cables from a crowded or convoluted conduit system for operational or maintenance requirements, steps should be taken to ensure easy access and maintainability of cable system right in the initial architectural design stage.

3.1.3 Telecommunications Room (TR)

3.1.3.1 A telecommunications room is the area within a building that houses the telecommunications cabling system equipment. This includes the mechanical terminators and/or cross-connects for floor-serving distribution facility for horizontal cabling and backbone cabling system. There should be at least one TR or TE per floor. TR or TE can also house active equipment, like LAN switches, routers, etc, or passive equipment, like optical splitters. Most of these equipment are available in wall mount units. The switches/routers can also be shared between telecom equipment and other low voltage in-building systems. This reduces the demand on floor space requirements for TR/TE. Sometimes, a TSP with the consent of the building owner may require to provide additional equipment, such as for mobile signal booster, at a later stage, in TR/TE. Therefore, it is recommended to have additional space in advance, specially in tall buildings of five storeys or higher, preferably on top floor.

3.1.3.2 Multiple rooms or TEs are required if the cable length between the horizontal cabling (floor distribution) [HC (FD)] and the work area outlet location, including slack, exceeds 90 m. If the usable floor space to be served exceeds 930 m², additional TRs should be considered. Following are the guidelines for TR size:

<i>Area Served</i>	<i>Dimension of TR</i>
465 m ² or less	3 m × 2.4 m
More than 465 m ² and less than equal to 930 m ²	3 m × 3.4 m

NOTE — The size of 3 m × 2.4 m has been specified to allow a centre rack, cabinet, or enclosure configuration.

In smaller buildings, less space is required to serve the telecom distribution needs of the occupants. The size guidelines for smaller buildings should be as below:

<i>Building Smaller Than</i>	<i>Served as</i>
465 m ²	Shallow/Walk-in rooms (Walk-in rooms shall be at least 1.3 m × 1.3 m. Shallow rooms shall be at least 0.6 m deep by 2.6 m wide.)
93 m ²	Wall cabinets, self-contained cabinets, enclosed cabinets

NOTE — Installation of active equipment in shallow or walk-in rooms is not recommended because many types of equipment require environmental controls and a depth of at least 1 m.

3.1.4 Entrance Facilities (EF)

Building entrance facilities (EF) provide the point at which outdoor cabling of the telecom service provider interfaces with the intra-building/intra-campus backbone cabling. In cases, where the functions of the EF are combined with the functions of the ER in the same space, the room may house equipment that is owned and maintained by service providers. In these cases, requirements specified by the service providers shall be considered when designing the ER.

If a separate space is required for service providers, it should be in or adjacent to the EF and may require a mesh partition or locked cabinet. A space of at least 1.2 m × 1.83 m shall be considered for each service provider. An entrance facility necessarily be an enclosed space. However, having an enclosed area or access protected area is suggested at all occasions, considering safety requirements.

The duct from the cable vault (CV) of the telecom service provider generally consists of 100 mm conduits encased in reinforced concrete. The exact number of conduits will depend upon the size and use of the building. These conduits may be used for all communication systems serving the building including additional capacity and access cables and pathways capacity. To maintain the safety of the TSP cable, it may preferably enter the building above the ground and then feed the equipment room.

A separate 230 V, 16/6 A circuit with double outlets should be provided (for plugging in temporary test equipment or to power the tools) every 2.4 m along the EF and ER combined wall. All wall outlets are to be located approximately 300 mm above the finished floor levels with the breaker and clearly labelled. In addition, two dedicated 230 V, 16/6 A sockets should be provided for each (permanently installed)

communication service rack. If the sockets of racks are fed from UPS power, appropriate levelling may be provided to distinguish between main power sockets and UPS power sockets.

3.1.5 Telecommunication Enclosures (TE)

A TE is simply a case or housing for telecom equipment, cable terminations, and cross-connect cabling for distribution of telecom services on a floor. The TE may also contain access points for wireless services. Although, TEs serve much in the same way as that of a TR, a minimum of one TE should be located on each floor, if no TR is considered on the floor. The TE door(s) may be hinged or removable. If the enclosure consists of metallic components, it shall be earthed.

3.2 Telecom Media and Connecting Hardware

3.2.1 A cabling system consists of cables, equipment cords, patch cords, and connecting hardware components. All balanced twisted-pair, optical fibre, and coaxial cabling systems are made up of such components. There can be different topologies for cabling used in a building like star, tree, bus bar, ring, etc, or a combination of these to suit different technological requirements. Within a building, most of the wiring is between the work spaces and the equipment room. Wireless systems can also be part of the telecom media. However, connectivity to the network, which delivers telecom service, is generally provided using cables at the back end.

The selection of appropriate style of cabling is important and accordingly, some of the user requirements to be considered before selecting the specifications and style of cabling and connectors for a telecom enabled building may include the following:

- a) Number of user work areas and telecom spaces used to serve the building occupants;
- b) Types of services and technology used for delivery of services;
- c) Number of telecom outlets/connectors desired at each user work area;
- d) Number and styles of user equipment (for example, telephony, LAN, building automation);
- e) Cabling system transmission performance expectations;
- f) Backbone distances and horizontal cable lengths involved in the building or campus;
- g) Future growth expectations (for example, 15 to 20 percent recommended minimum growth factor);

- h) Environmental conditions including electromagnetic interference; and
- j) Other types of low voltage systems and their network requirements.

3.2.2 The cables should have ferrule marking at the terminations as well as along the length of the cable at suitable interval. Similarly, copper pair/fibre pair should be identifiable at terminating end for easy identification and convenience during maintenance. For the purpose, a suitable chart should be available at locations, like inside cross-connect box. Further, all the documentation of pathways and cables should be properly maintained.

3.2.3 While designing the cabling system for large multi-tenant building, it should be kept in mind that the tenants may prefer subscribing to the services of multiple service providers. Thus, enough space should be available in ducts, pathways, etc, for laying additional conduits/trays, keeping in view the present and future demands. Capacity for pathways (that is, conduit, raceways, trays, baskets) may be planned so that initial installation achieves a fill of 40 percent and at final installation, fill of 60 percent, taking into account the expected future requirements.

3.2.4 Various cabling systems are described under **3.2.4.1** to **3.2.4.3**. For the purpose of reference, the details about connecting hardware components and classification of cables by fire safety properties are given in Annex A.

3.2.4.1 Copper twisted-pair

The transmission performance of balanced twisted-pair cabling and telecom associated components are based on a number of factors within the cabling or component design. These performance levels use the terms category and class. Standards developed internationally utilize both class and category, depending on the specific cabling element, as described in Table 1.

A large number of cable designs are used in the ICT industry, resulting in various names and acronyms for their identification. The ISO/IEC 11801 : 2002 'Information technology — Generic cabling for customer premises', gives balanced twisted-pair cable designations using x/y designation, where x is the overall screen type and y is the individual pair screen type, which may be used. Details of various nomenclature based on this, using various categories of cables, are given in Annex A.

3.2.4.2 Optical fibre

Optical fibre cables are used in backbone and horizontal cabling applications, when the service is delivered on fibre to the user or inter/intra building communication is to be carried on fibre. Example of former is GPON

Table 1 Balanced Twisted-Pair Cabling Channel Performance
(Clause 3.2.4.1)

SI No.	ISO Category/Class	TIA Category	Frequency MHz	Maximum Data Transfer Rate
(1)	(2)	(3)	(4)	(5)
i)	Category 3/Class C	Category 3	16	10 Mbps
ii)	Category 5/Class D	Category 5e	100	100 Mbps
iii)	Category 6/Class E	Category 6	250	10 Gbps
iv)	Category 6A/Class EA	Category 6A	500	10 Gbps
v)	Category 7/Class F	NA	600	10 Gbps
vi)	Category 7A/Class FA	NA	1 000	—
vii)	Category 8/Class G	Category 8	1 500 to 2 000	—

(Gigabit Passive Optical Network), which require Fibre to Home (FTTH) and the example of latter is LAN implementation using optical network. Transmission of information through optical fibre cables is not degraded by crosstalk, ambient noise, lightning, and most electromagnetic interference (EMI). It has better loss characteristics compared to copper pair. Thus it permits high data rate communication to be carried out to much larger distances than copper pair.

Optical fibres are classified as either single-mode or multi-mode. Single-mode optical fibres have a relatively small diameter featuring a core of 8 to 11 µm and a cladding diameter of approximately 125 µm. Multi-mode optical fibre has a larger core diameter (for example, 50 µm or 62.5 µm) with the cladding of approximately 125 µm. Multi-mode fibre has higher loss compared to single-mode fibre. However, it is generally recommended for in building/intra campus use as it cost less than the single fibre. The latter has low loss characteristics and can carry higher speed to longer distances due to which it is mainly used in long haul applications. However, depending upon the size of the building/campus or availability of various types of cables, combination of both types of cables or only single-mode cable may need to be used. Use of single-mode fibre has the advantage that future upgradation requirements are taken care of right in the beginning.

Optical fibre cables are available in various capacities in terms of number of fibres like 6 fibre, 12 fibre, 24 fibre, 48 fibre, 96 fibre, etc. Each fibre has a different colour which helps in easier identification during installation and operations. The colour scheme is repeated for every group of 12 fibres for higher fibre

count cables. Selection of optical fibre cable size for different segments of cabling depends upon various factors.

The colour code chart for fibre optic cable is as under:

Fibre/Tube No.	Colour
1	Blue
2	Orange
3	Green
4	Brown
5	Gray
6	White
7	Red
8	Black
9	Yellow
10	Purple
11	Rose
12	Aqua

NOTE — The specifications of the certain types of optical fibre cables are available in Department of Telecommunications, Telecom Engineering Centre (TEC), Govt of India, the details of which can be seen from TEC website, www.tec.gov.in.

When it is decided to use optical fibre cable, choice is to be made from among variety of standard cables. There are two broad categories of cables namely OM (multi-mode optical fibre) and OS (single-mode optical fibre). The former is suitable for much shorter distances compared to the later as, data rate supported by cable is a function of cable length used. OM cables are preferred cables for campus applications as they are economical for short distances. OM cables are further sub-categorized into OM1, OM2, OM3 and OM4, which are differentiated based on data speed and distance combinations. Once the data speed and distance to be covered is decided, choice of cable category becomes simpler. When used inside the buildings, attenuation of signals is caused due to cable fibres facing sharp bends. Multi-mode cables show larger attenuation than single-mode cables on bends inside the building.

Considering that backbone cable carries the combined traffic of all work areas and the growth of data use with time, provision for future expansion should be provided. It is recommended that planning should be done for 10 Gbps and above speeds. Therefore, when using multi-mode cable, choice may need to be made typically from among OM3 and OM4 cables.

A chart showing typical length and data rate support characteristics of various cables is given below:

<i>Subsystem</i>	<i>Backbone Lengths Up to</i>	<i>Data Rates Up to</i>
Campus backbones (OM1 fibre)	2 000 m	155 Mb/s
Campus backbones (OM2 fibre)	550 m	1 Gb/s
Building backbones (OM2 fibre)	300 m	1 Gb/s
Building backbones (OM3 fibre)	300 m	10 Gb/s
Building backbones (OM3 fibre)	100 m	100 Gb/s
Campus/building backbones (OM4 fibre)	550 m	10 Gb/s
Campus/building backbones (OM4 fibre)	150 m	100 Gb/s
Campus/building backbones (OS fibre)	10 000 m	100 Gb/s

Enhanced versions of OM3/OM4 cables can also be examined for use. Once the cable category is selected, care should be taken that active equipment which feeds the fibre is equipped with the corresponding interface, to take care of, for example requirement of different optical power source and optical wavelengths for different types of cables.

3.2.4.3 Coaxial cable

The predominant coaxial cables are Series-6, Series-11, and radio grade (RG) 59. These coaxial cables have a characteristic impedance of 75 Ω. While the termination procedures may be similar, special attention shall be paid to the manufacturer’s specific instructions for termination and connectors. The cables/passive components used for DAS/IBS system should cover frequency range from 400 MHz to 2 300 MHz.

Coaxial cable is used for computer networks, CATV and video systems. Historically, coaxial cable was designated as RG cable. Coaxial cables used in broadband applications are available in the market with following constructional variations:

- a) Centre conductor diameter;
- b) Centre conductor being solid or stranded;
- c) Dielectric composition;
- d) Outer braid’s percent of coverage; and
- e) Impedance.

3.2.5 Wireless Systems

Wireless connectivity is also provided inside the building for enabling access to public mobile network or for enabling internet/intranet connectivity with flexibility of user terminal movement. Various wireless systems are described below:

- a) *Wireless LAN (WLAN) access point (AP)* — A wireless LAN (WLAN) access point (AP) is a network device located in areas of a building or campus and placed in relatively close proximity to where users interact with their

wireless enabled network devices. APs allow wireless enabled devices (for example, computer, printer) to connect through Wi-Fi or related standards. Wireless networks here can even include the networks of low voltage automation system in the building as well as M2M/IoT smart buildings/smart homes/smart offices. There are various wireless standards for M2M/IoT device connectivity. AP network devices are typically mounted on walls or ceilings with structured cabling that provides a physical connection to a HC (FD), which provides further connectivity to private/public network through the facility installed in TR/TE.

- b) *Wi-Fi access points (WAP) with centralized controller* — Access point shall support 802.11 a/b/g/n. There may be numbers of WAPs to cover area/building and in such situation user may prefer centralized controller. Centralized controller can be hardware or software based and depending upon number of WAPs may be provided at each ER/TR/TE. These access points can also be used for connecting the low voltage automation systems (building management system and other in-building system). The access points are connected to the network as described in (a).
- c) *Distributed antenna systems (DAS)/In-building solutions (IBS)* — DAS/IBS are signal distribution systems for strengthening the public mobile wireless signal inside the buildings or installations. They require cable and passive antenna to be installed in corridors/rooms, normally along the centre line. The active equipment, wherever required can be installed in ER/TR/TE, on which cables to/from DAS/IBS are connected.
- d) *Wireless repeater* — It takes an existing signal from a wireless router or wireless access point and rebroadcast it with amplified signal. It is also called wireless range extender. This is used to mitigate low signal issues.

While installing wireless devices, it is required to maintain enough spacing between them to avoid frequency overlap and interference by their own signal. The wireless coverage area radius is impacted by a number of factors including the following, and these factors are to be taken into account by using the site survey approach:

- 1) Building materials (concrete, sheetrock, wood, steel, etc);
- 2) Building configuration (closed, semi-closed or open space); and

- 3) Building furnishings (cabinets, partitions, furniture, etc).

3.2.6 Connecting Hardware

The ends of cable terminating in work areas or on intermediate equipment like LAN switches, splitters, etc, need to be provided with connectors. There can be variety of equipment which may be connected to the cable ends. Hence a careful planning should be done to identify types of connectors with flexibility to connect variety of equipment keeping in view also the fact that the cable ends are permanently wired on to connector panels in the work areas. Details of the typical connecting hardware are given in Annex A.

3.3 Backbone Cabling Media Distribution and Building Pathways

The backbone distribution system provides interconnection between telecom spaces, that is, telecommunication rooms, equipment rooms and entrance facilities. It consists of the backbone cables, intermediate and main cross-connects, mechanical terminations and patch cords or jumpers used for backbone-to-backbone cross-connection. This includes,

- a) vertical cable connections between floors (risers);
- b) cables between an equipment room and building cable entrance facilities; and
- c) cables between buildings (inter building).

The elements of the telecommunications cabling system structure are:

- 1) Horizontal cabling,
- 2) Backbone cabling,
- 3) Work area,
- 4) Telecommunications rooms,
- 5) Equipment rooms, and
- 6) Entrance facilities.

Figure 1 illustrates a representative model for the various functional elements that comprise a building campus/complex telecommunications cabling system. It depicts the relationship between the elements and how they are configured to create a total system.

3.3.1 Backbone Cabling and Topologies

Cabling between the building cross-connect (main or intermediate) and the horizontal cabling (floor distribution) [HC (FD)] is designated as backbone cabling. In a multi-building complex, inter-building cabling, though terminating in the EF, is designated as inter-building backbone cabling. The cable(s) can be of any type, for example, copper pair, optical fibre or coaxial.

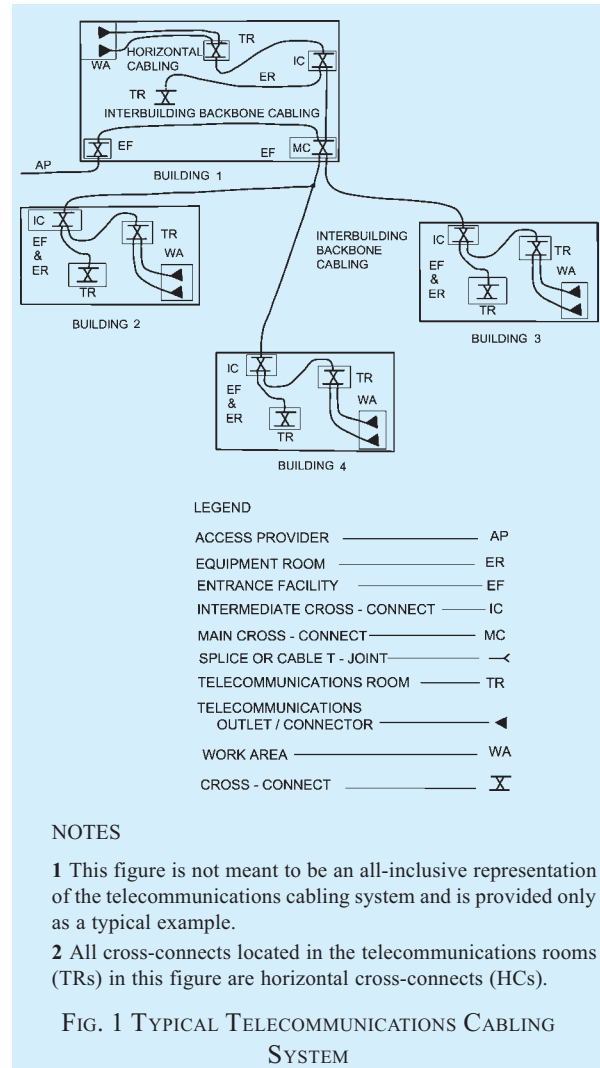

3.3.1.1 The two primary options for connectivity are:

- a) Star topology, where the HC (FD) is connected directly to the main cross-connect (campus distributor) [MC (CD)] which is further connected to inter building backbone, where applicable.
- b) Hierarchical star topology, where some or all of the HCs (FDs) are connected to an intermediate cross-connect (building distributor) [IC (BD)], which in turn, is connected to the MC (CD).

3.3.1.2 The best design is the star design between the building MC and the HCs. However, in some extremely large buildings (for example, high-rises), a hierarchical star may be an option for consideration. The trade-offs between different cable sizes and labour cost is to be considered to determine a suitable cost effective solution. The direct connections between HCs are generally avoided. Although this kind of connectivity might be of value in providing a redundant path, a user should design a link from HC to HC only in specific

applications. The best design is the star design between the building MC and the HCs.

3.3.1.3 A typical star configuration in a building with MC (CD) or HC (FD) is given Fig. 2.

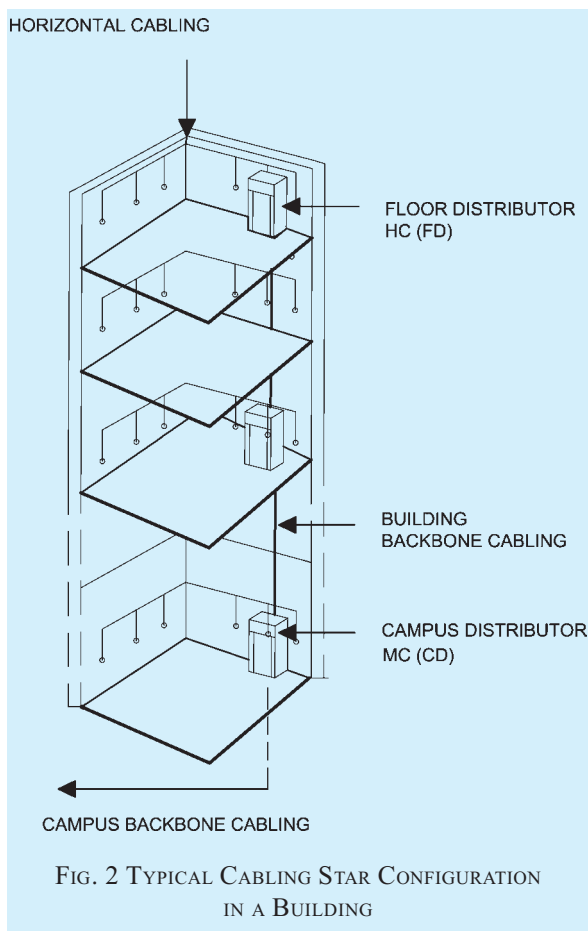

3.3.1.4 An example of backbone hierarchical star topology with addition of IC (BD) is shown in Fig. 3.

3.3.2 Inter-Building Pathways

In a campus environment, inter-building pathways are required to connect separate buildings. For this, underground, buried, aerial and tunnel are the main pathway types used. As the complexes have varying conditions of land features and locations, size and use of building, choice if any or combination of the pathways need to be made based on local requirements. The cable running over the pathways generally terminates at the entrance facility of the building at both ends.

3.3.2.1 Underground inter-building backbone pathways

The pathway shall be fully covered and the cabling shall be installed within protective conduit or ducting for the entire external section of the cable route in all inter-building pathways. Provision should be made for

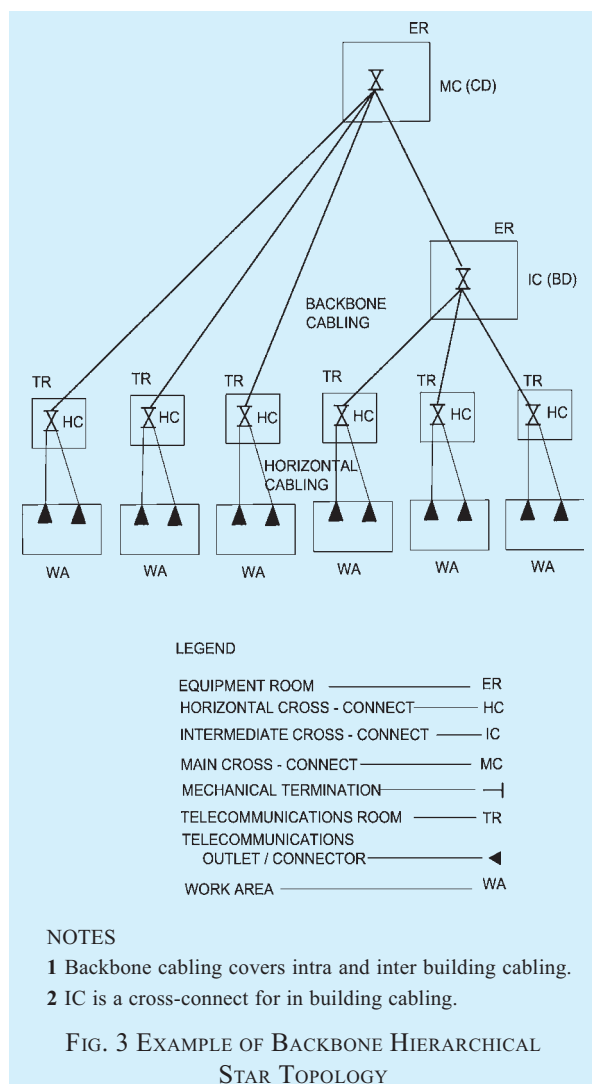

existing as well as future demand. Underground pathways consist of conduit, ducts and troughs; possibly including manholes. The manhole can be planned normally, if

- a) the cable requires joint;
- b) the distribution of copper/fibre pair is required midway; or
- c) numbers of bends in the path are more than two.

Each manhole should be dimensioned to accommodate spare cable of 2 m to 4 m length in each direction, which is generally kept in spare loop to take care of maintenance needs. All conduit and duct shall have a diameter of at least 100 mm. Bends are not recommended; however, if required, there should be not more than two 90° bends.

In a multi-building and multi-operator campus, an Underground Cable Vault (UCV) may be considered close to entrance facility. Manholes/pull holes may also

be provided for O and M activity in the outside plant pathway system for the pulling, placing, and splicing of cables. Size of UCV, manholes and pull holes should be decided based on the pathway capacity, number and types of cables, etc. All such points should be covered with properly marked iron covers of appropriate thickness and structural support below them keeping in view the load they are expected to bear due to pedestrian or vehicle movement.

In the planning for underground cabling, the following shall be considered:

- 1) Limitations dictated by the topology (this includes land development);
- 2) Grading of the underground pathway to permit proper drainage;
- 3) Need to vent gaseous vapours; and
- 4) Amount of vehicle traffic to determine the amount of cover over the pathway and whether or not concrete encasement is required.

3.3.2.2 Direct buried inter-building backbone pathways

In this case, the telecommunications cables are completely covered in earth. Direct burial of telecommunications cables is achieved by trenching, augering or boring (pipe-pushing). When selecting a route for the pathway, it is important to consider the landscaping, fencing, trees, paved areas and other possible services. Direct burial has the challenges of cable repair in case of faults and also in future upgradation.

3.3.2.3 Aerial inter-building backbone pathways

An aerial pathway consists of poles, cable-support strand and support system. Some considerations to make when using aerial backbone include the following:

- a) Appearance of the building and surrounding areas;
- b) Separation and clearances for electrical installations and roads;
- c) Span length, building attachments, storm loading and mechanical protection; and
- d) Initial number of cables and future growth potential.

3.3.2.4 Tunnel inter-building backbone pathways

Tunnels provide pathways for conduit, trays, wire-ways or support strand. Normally tunnels support other building services too. Hence, the location of telecom pathways within a tunnel should be planned to allow for accessibility as well as for separation from other services. In general, tunnelling inside the premises for telecom services alone may not be cost effective.

3.3.3 Backbone Building Pathways

Backbone building pathways can be built in various ways depending upon the building layout, locations of TR/TE, etc. While designing and implementing such pathways, certain requirements need to be met and precaution taken. Typical topologies and requirements/precautions relating to these are described below:

- a) *Vertically pathway topology* — Vertically aligned TRs with connecting sleeves or slots are the most common type of backbone pathway though it is not a necessary condition. Vertical alignment is desirable because the building planner can stack them with other mechanical spaces, and it makes distribution of telecom cables more efficient because of shorter conduits and cabling runs.

If the TRs/TEs are not aligned vertically above one another, the conduits interconnecting them will have horizontal offsets. There shall be not more than two 90° bends in any such conduit run. Any bend shall have an inside radius 10 times the diameter of the conduit (typically 1 m). If these conditions cannot be met, then intermediate pull boxes shall be used wherever a non-standard transition is required. This pull box shall be at least 600 mm × 600 mm in the plane of the attached conduits, and 150 mm deep. All conduits other than simple sleeves between floors shall be fitted with a continuous 1.5 mm nylon pull rope, or a 0.6 mm steel fish wire or a 0.5 mm fibre composite fish wire.

- b) *Conduits, trays, slots, sleeves, and ducts* — All rigid metallic conduit pipes shall be of steel and shall be conforming to accepted standard [8-6(1)]. The wall thickness of the pipe shall be not less than 1.6 mm (16 SWG) for conduits up to 32 mm diameter and not less than 2 mm (14 SWG) for conduits above 32 mm diameter. These shall be solid drawn or reamed by welding, and finished with galvanized or stove enamelled surface.

All non-metallic conduit pipes and accessories shall be of suitable material complying with the accepted standards [8-6(2)] for rigid conduits, and accepted standards [8-6(3)] for flexible conduits. Such pipes shall not be exposed.

The vertical backbone pathway consists of telecommunications rooms located on each floor, tied together by sleeves or slots. In this context, the term 'sleeve' refers to a circular opening in a wall, ceiling or floor to permit the passage of cables between adjacent spaces.

A 'slot' is the same as a 'sleeve', except that the shape of the opening is usually rectangular. The cable sleeves or slots are positioned adjacent to a wall on which the backbone cables can be supported. The recommendation in respect of slots and sleeves are as under:

- 1) Slots with a minimum 25 mm high curb.
 - 2) Sleeves to extend a minimum of 25 mm above the floor level and a maximum of 77 mm above the floor level. Sleeves should be located at a minimum of 25 mm from the wall or between adjacent sleeves to provide room for bushings, but not so far from the wall that it becomes a tripping hazard or create too large a cable span from the sleeve to the backboard/tray.
- c) *Riser systems* — For connectivity to TR/TE on upper floors from the building EF, conduit or raceway should preferably be provided vertically. Vertically mounted ladder rack shall be mounted on the wall between incoming and outgoing sleeves within the TR/TE. The ladder rack should be used to provide strain-relief for cables transiting TR/TE within the riser system. If the building plan is large enough to require a second communications TR/TE on one or more floors, then the riser pathway should preferably be duplicated from the EF up to second set of TR/TE.
- d) *Vertical pathway size* — A minimum of three 100 mm diameter conduits, or equivalent raceway cross section, should be provided between the TR/TE on adjacent floors and between the EF and the first floor TR/TE.
- e) *Access to the roof* — For installations like antenna, powering the roof top/tower top equipment, access shall be provided through suitable number of conduits. This connectivity from the roof should be seepage and rodent proof. A minimum of two 75 mm and one 20 mm conduit shall extend from the topmost TR/TE to the roof terminated in a weatherproof metal enclosure. Sometimes, it may not be feasible or desirable to have direct vertical access, thus requiring horizontal extension from the rooms before vertical extension, the user may keep this in view for taking action with respect to architectural considerations.
- f) *Pathway finish details* — Conduit shall be free of burrs or sharp edges. Sheet metal sleeves, if used, shall have rolled edges. Conduits or sleeves shall protrude at least 25 mm from the surface they penetrate but not more than 75 mm. Conduits shall be fitted with a smooth bushing.

- g) *Fire protection of shafts* — All penetrations shall be filled with fire resistant material. Fire compartment plan and integrity of compartment should be maintained by either blocking permanently or by recognized systems automatically responding to temperature increase.
- h) *Open cable shafts* — Open cable shafts should be used when available and where large quantities of cables are required on a floor that is distant from the main ER. Backbone cable pathways shall not be located in elevator shafts.
- j) *Enclosed metallic raceways or conduits* — Enclosed metallic raceways or conduits are also used as vertical and horizontal cable pathways. It should be bonded to form a common bonding network.
- k) *Cable trays* — A cable tray can be used as a vertical cable pathway within shafts or as part of the pathway between vertically aligned TRs. A cable tray can be open or covered and provides a means for attaching vertical cable runs to the cable tray members. The cable tray can also accommodate ethernet LAN cables running from building management system and other low voltage automation system in the building.

3.3.4 Ethernet in the First Mile (EFM)

Ethernet in the first mile (EFM), also known as ethernet to the last mile, describes the access network from the access point to the subscriber's premise. The first mile is the critical connection from business and residential users to the public and the public network.

Ethernet is the dominant mode of digital connectivity to user computers and other devices. Local Area Network (LAN) connectivity is extended to the end user computers through ethernet cable and connector. Ethernet cables generally used are Cat 5e and Cat 6. However, higher categories of cables are available (Cat 7 and Cat 8), which supports data rates of 10 Gbps and 40 Gbps. In many implementations, backbone and horizontal cabling may be on optical fibre. Such implementations address the Cat 5e/Cat 6 cable length limitations as only the last drop from TR/TE to the work area will use Cat 5e/ Cat 6 cable.

However, in many large buildings, optical to ethernet converters/switches may be required to be installed beyond TR/TE also, which may be installed in safe places in corridors false ceiling, work area, etc, where provision for supply of power should also be made. This holds true for Cat 5e/Cat 6 backbone and/or horizontal cabling also. Cabling to work area may be

through conduits inside the wall or conduits on open surfaces. In cases where multiple tenants want to set up their own LAN, they may set up their system and horizontal cabling. However, they should preferably use backbone cabling of the building to reach EF for further connectivity to a telecom service provider for internet/leased bandwidth, etc.

3.4 Horizontal Cabling Media Distribution and Building Pathways

A horizontal distribution system consists of the horizontal cabling, the horizontal pathways supporting the horizontal cabling, and the telecom spaces that support the horizontal pathways. As horizontal distribution systems, cabling, and pathways often change direction, elevation, or physical orientation to accommodate obstructions, barriers, and other building systems, the use of the term horizontal in the name of the element does not require that the elements be placed or installed parallel to the ground or floor.

3.4.1 Horizontal Cabling Systems

3.4.1.1 The horizontal cabling is the portion of the telecommunications cabling system that extends from the work area telecommunications outlet/connector to the horizontal cross-connect in the telecommunications room (TR). The horizontal cabling includes horizontal cables, telecommunications outlet/connectors in the work area, mechanical terminations, and patch cords or jumpers located in the telecommunications room, and may include multi-user telecommunications outlet assemblies and consolidation points.

The following media types can be considered as options for horizontal cabling:

- a) Four-pair 100 Ω unshielded twisted-pair (UTP) or screened twisted-pair (ScTP) cables with a distance limit of 90 m taking care of 10 m patch cord/jumper cable required for work area.
- b) In case of optical fibre, OM cable normally of grade lower than or equal to the backbone cable may be selected. Such limitation is not faced if OS or appropriate ITU-T standard single-mode cables as mentioned in **3.2.4.2** are used. Distance limits with respect to data rate to be supported on horizontal cabling system may be seen from table under **3.2.4.2**. Care should be taken that the equipment for corresponding fibre interface is selected.

While laying cables, maximum recommended length of cable by including provision for jumper cables/patch cords in TR and extension in work area should be kept in view.

3.4.2 The requirements for horizontal pathways, measures for avoiding electromagnetic interference in the design of cabling pathways are described in **3.4.2.1** and **3.4.2.2**.

3.4.2.1 Horizontal pathways

Horizontal pathways are used for distributing, supporting, and providing access to horizontal cabling and telecom associated connecting hardware between the telecom outlets/connectors and the HC, typically located in the ER, TR or TE. Horizontal cabling is contained within horizontal pathways. Generally, the horizontal pathways are one of two types:

- a) Continuous pathways (for example, conduit, cable tray, cable matting) used for containment of telecom cabling.
- b) Non-continuous pathways (for example, the space between cable supports such as J-hooks) through which cables are placed between physical supports or containment components.

A pathway component should be designed to accommodate all standards compliant cabling and address the potential need for change and expansion during the life cycle of the cabling system and building. The emphasis should be first on the design of pathway systems and then on the cabling systems design. This approach helps to ensure a robust pathway system that supports the cabling installation over the facility's life cycle. As frequently accessing or changing the horizontal cabling leads to disruption to occupants, the choice and layout of horizontal cabling types are important to the design of the building structured cabling system. The following should be considered for the horizontal distribution system's design:

- 1) Allow for the accommodation of change over the facility's life cycle with the goal of reducing long-term maintenance and operational costs.
- 2) Utilize standardized cabling, components and systems.
- 3) Include appropriate pathway and cabling components to accommodate ease of access and a variety of user specified technology applications.

The horizontal cabling system should be designed in order to support various telecom applications, including,

- i) voice services;
- ii) data services;
- iii) audio and video services; and
- iv) building signalling systems [for example, smart building ICT systems, building

automation systems (BAS), and fire safety and security systems].

It is preferable to have provision for conduits, junction box, etc, during planning and construction stage for providing radio/wireless data equipment at the centre line of rooms and corridors to avoid unplanned provisions later on.

3.4.2.2 Avoiding electromagnetic interference (EMI)

Avoiding electromagnetic interference (EMI) is an important consideration in the design of cabling pathways. Providing physical separation from sources of EMI for these elements of the telecom infrastructure inherently provides separation of their contents (for example, cable and connecting hardware).

The telecom pathways should be located away from sources of EMI to the extent feasible, including,

- a) electrical power cabling and transformers;
- b) rf sources;
- c) large motors and generators;
- d) induction heaters;
- e) arc welders;
- f) X-ray equipment; and
- g) photocopy equipment.

3.4.2.3 Topology

Horizontal cabling should be installed in a physical star topology. Each telecom outlet/connector should be cabled directly to an HC (FD) in the appropriate telecom space. Exceptions to this practice are possible, when,

- a) a consolidation point (CP) or multi-user telecommunications outlet assembly (MUTOA) is used to connect the open office cabling;
- b) a transition point (TP) is required the connect to under-carpet cabling; or
- c) centralized optical fibre cabling is implemented from main cross-connect (campus distributor) [MC (CD)] to the work area(s).

Some applications may utilize a bus, ring, or tree topology, which can be implemented within a physical star topology. However, in case of large number of work areas, ring or tree topology may require intermediate distribution points like MUTOA, etc. Typical horizontal and work area cabling using a star topology is shown in Fig. 4.

3.4.2.4 Work areas and open office cabling

3.4.2.4.1 The work area includes those spaces in a building where occupants normally work and interact

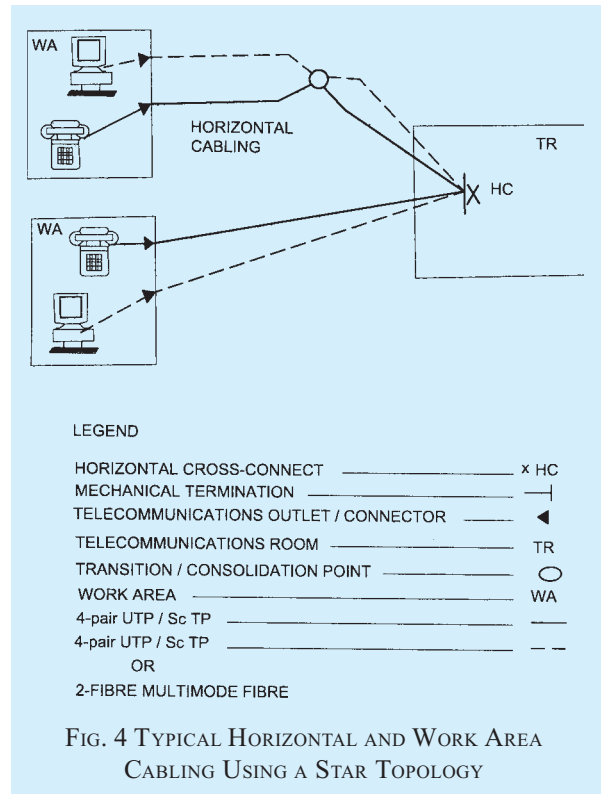

FIG. 4 TYPICAL HORIZONTAL AND WORK AREA CABLING USING A STAR TOPOLOGY

with their ICT equipment. While work areas have traditionally been fixed, discrete locations, open office cabling design practices have introduced flexible layouts to support collaborative work by small teams. Such spaces are often rearranged to meet changing requirements of group work. Many other open office work situations also require frequent reconfiguration. An interconnection in the horizontal cabling allows open office spaces to be reconfigured frequently without disturbing horizontal system cabling runs. Work area equipment that may require access to the horizontal cabling includes,

- a) telephones;
- b) networking equipment;
- c) fax machines;
- d) computers;
- e) network peripherals; and
- f) any device plugged into a telecom outlet/connector that is located within the work area.

3.4.2.4.2 The key elements of open office cabling are the MUTOA and CP. To accommodate equipment in the work area, following components are typically used as needed:

- a) Telecom outlet/connector.
- b) Work area equipment cords.
- c) MUTOAs and CPs.
- d) WAPs.

Some of these components and requirements or recommendations relating to them are described below:

- 1) *Multi-user telecom outlet assembly (MUTOA)* — The MUTOA serves as a method of connecting more than one user (work area) to the horizontal cabling system. MUTOAs may be advantageous in open office spaces that are moved or reconfigured frequently. A MUTOA facilitates the termination of horizontal cabling system cables in a common location within a furniture cluster or similar open area. The use of MUTOAs allows the horizontal cabling to remain unchanged when the open office plan is changed. Work area equipment cords originating from the MUTOA should be routed through work area pathways (for example, furniture pathways). Each furniture cluster should have one MUTOA which may typically serve 12 work spaces. The work area equipment cords shall be connected directly to work area equipment without any additional connections. For copper cables, any combination of horizontal, work area cables and equipment cords may not exceed 100 m. The work area cables shall be connected directly to work station equipment without the use of any additional intermediate connections (see Fig. 5).
- 2) *Consolidation point (CP)* — The consolidation point (CP) is an interconnection point within the horizontal cabling system. Like the MUTOA, a CP may be used for balanced twisted-pair cabling or optical fibre cabling. The functional difference between the CP and the MUTOA in the open office environment is that the CP introduces an additional connection for each horizontal cabling run. A CP may be useful when reconfiguration is not so frequent as to require the flexibility of the MUTOA. The CP may

be located in the suspended ceilings, access floors, modular office furniture or work area. Further CPs may serve a zone consisting of number of work areas even in different rooms.

Some additional considerations and guidelines that apply specifically to the CP are as under:

- i) Cross-connections should not be used at a CP. Not more than one CP should be used within the same horizontal system cable run so as to avoid additional points of failure. Depending upon the size and number of the cables, there can be a single CP for all cables or separate CPs for different sets of cables.
- ii) For balanced twisted-pair cabling, the CP should be located at least 15 m from the HC (FD) in order to reduce the effect of Near End Cross Talk (NEXT) and return loss from multiple connections in close proximity.
- iii) CPs shall be located in fully accessible and permanent locations. CPs shall not be located in an obstructed area.
- iv) The CP should be sized and cabled so that it meets the telecom requirements of the zone it serves. If the floor space requirements change for an existing CP, then the CP should be reconfigured to accommodate the new requirements (see Fig. 6).

3.4.2.5 Centralized optical fibre cabling (fibre to the desk)

The HCs (FD), deployed throughout a building and located on each floor of a building, offers maximum flexibility to the user, especially in the deployment of distributed electronics or in multi-tenant buildings. In spite of the advantages of distributed cross-connections, some users may prefer data networks with centralized electronics which requires centralized cabling to provide connections from the work areas to the centralized cross-connect. Any of the following methods can be used for cabling:

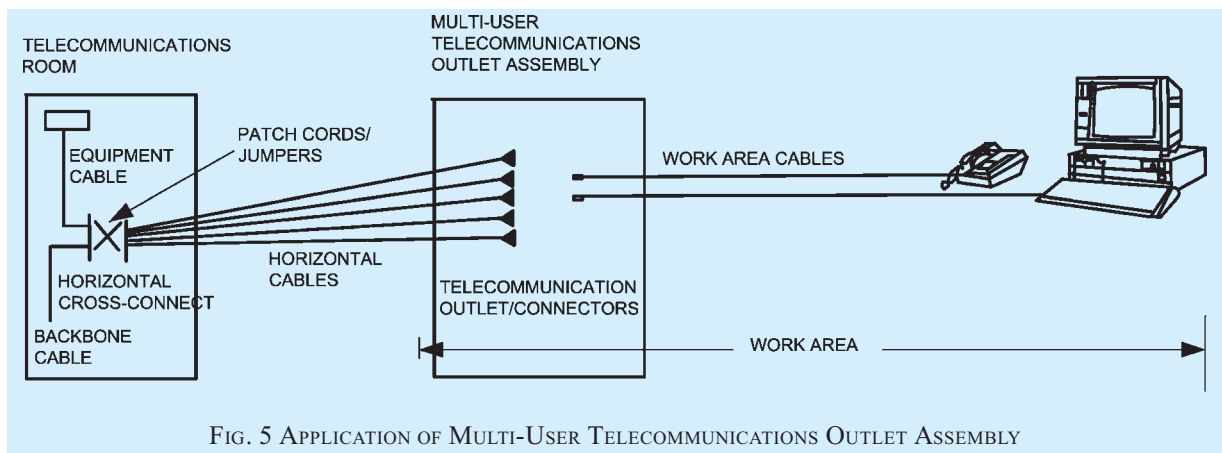

FIG. 5 APPLICATION OF MULTI-USER TELECOMMUNICATIONS OUTLET ASSEMBLY

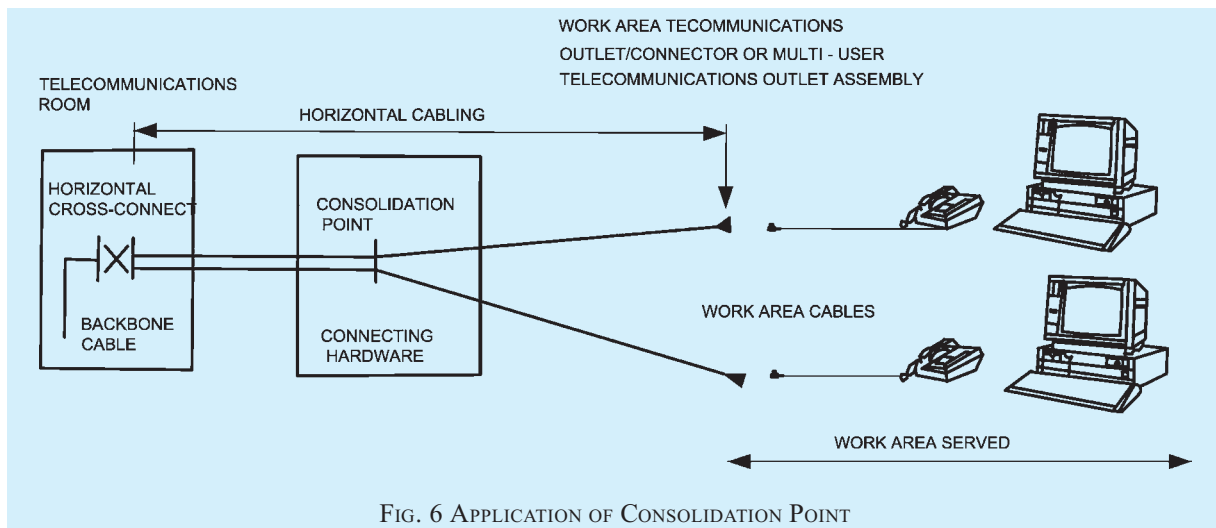

FIG. 6 APPLICATION OF CONSOLIDATION POINT

- a) Pull-through cabling from the centralized cross-connection;
- b) Interconnection cabling in a floor-serving telecom space; and
- c) Spliced cabling in a floor-serving telecom space.

However, flexibility for rearrangement of work areas and need for additional work areas in future by the user should be kept in view while adopting any of the above methods.

4 SPECIFIC REQUIREMENTS FOR TELECOM INFRASTRUCTURE CABLING

4.1 Telecommunications Bonding and Grounding

The bonding and grounding (earthing) infrastructure of a telecom installation is an essential part of an information technology systems (ICT) design. Grounding systems are an integral part of the signal or telecommunications cabling system that they support. In addition to helping protect personnel and equipment from hazardous voltages, a proper grounding system may reduce electromagnetic interference (EMI) to and from the telecommunications cabling system. Improper grounding can produce induced voltages and those voltages can disrupt other telecommunications circuits. Grounding and bonding shall meet the appropriate requirements and practices of applicable standards.

The overall purpose for the ICTs bonding infrastructure is to equalize potentials between metallic surfaces predominantly in the event of lightning, a.c. electrical system faults, electromagnetic induction, or electrostatic discharge.

The Telecommunication Main Grounding Bus Bar (TMGB) serves as the dedicated extension of the building a.c. grounding (earthing) electrode system for the ICTs infrastructure. It serves as the central

attachment point for the Telecom Bonding Backbone (TBB). A Telecom Grounding Bus Bar (TGB) is the grounding (earthing) connection point for ICTs infrastructure systems (for example, cabling, pathways) and ICTs equipment in the area served by an ER or TR. The TMGB and TGB should be a pre-drilled copper bus bar with holes for use with standard-sized lugs. A TBB is a ICTs bonding conductor to connect equipment/TRs/TEs on multiple floors of a building with an ultimate connection to the TMGB. Typical telecommunication grounding and bonding arrangement is shown in Fig. 7.

TMGB is recommended for minimum dimensions of 6.35 mm (¼ inch) thick, 101.6 mm (4 inch) wide and variable in length. The TBB dimensions are as under:

TBB Length Linear m	TBB Size AWG
Less than 4	6 (13.29)
4 to 6	4 (21.14)
6 to 8	3 (26.65)
8 to 10	2 (33.61)
10 to 13	1 (42.39)
13 to 16	1/0 (53.46)
16 to 20	2/0 (67.40)
Greater than 20	3/0 (84.97)

NOTE — The figures given in parentheses are in mm².

4.2 Installation and Workplace Safety

4.2.1 Cabling Installation Guidelines

The installation of system components has a tremendous effect on the final performance level of the network; therefore, it is essential to ensure that the performance of the entire network is not diminished through improper installation. The cables can be easily

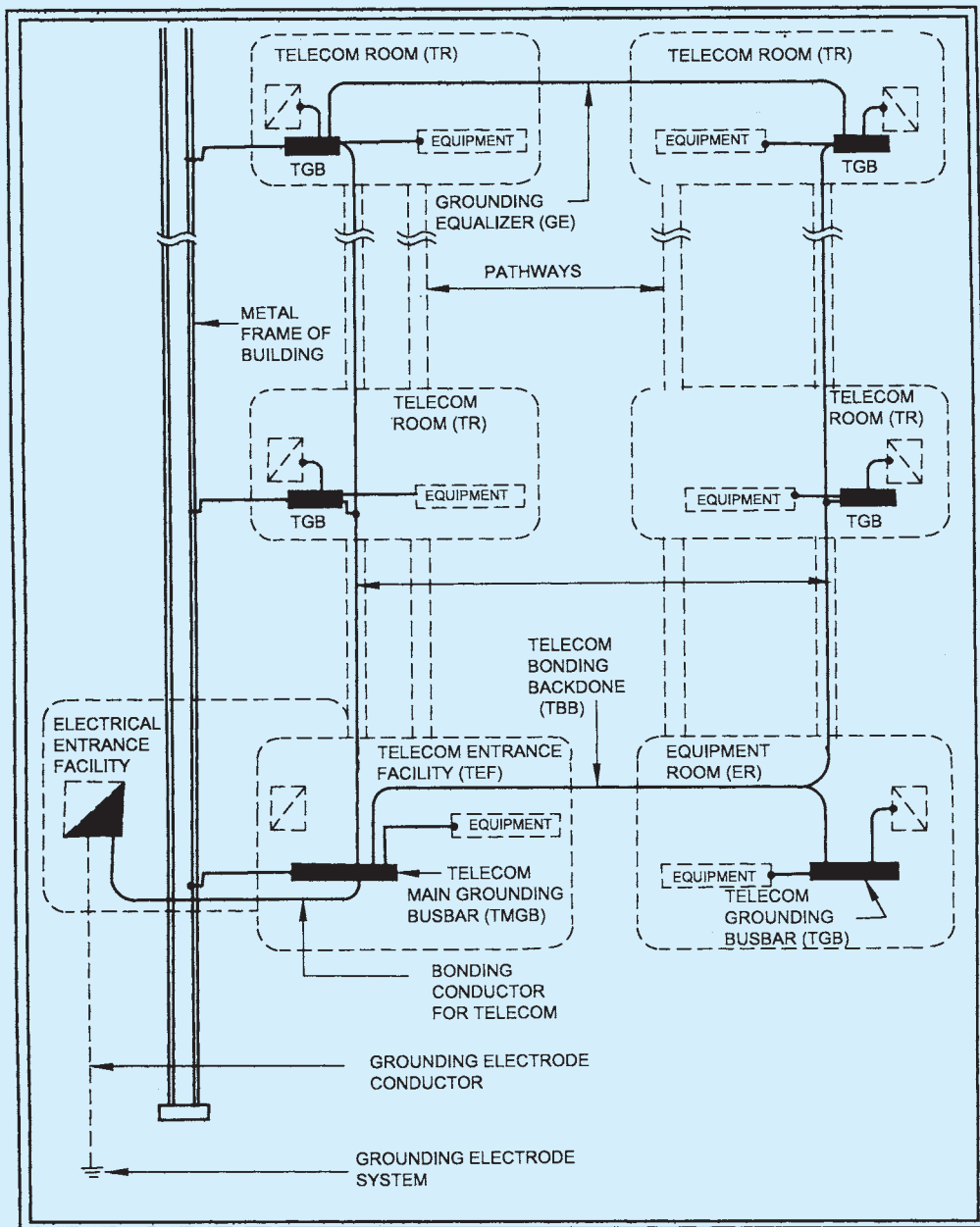

LEGEND





- BUILDING STEEL 
- GROUNDING BAR 
- SERVICE EQUIPMENT 
- PANELBOARD 
- BONDING CONDUCTOR AS LABELLED 

FIG. 7 TYPICAL TELECOMMUNICATION GROUNDING AND BONDING ARRANGEMENT

damaged if they are improperly handled or installed. It is imperative that certain procedures be followed in the handling of these cables to avoid damage and/or limiting their usefulness.

Care shall be taken not to stretch or abrade cables during installation, that is, the pulling tension for cables shall not be exceeded. Cables that pass through the infrastructure of the building shall be suitably protected against damage. Through walls and floors, this shall involve an appropriate type of sleeve; through any form of metalwork or stiff plastic then a rubber grommet shall be used.

To ensure cable management and also strain relief, cables shall be properly dressed using velcro cable ties. However, cable's ties should never be over tightened. On vertical runs, the cables shall be dressed and tied from the bottom up, thus putting minimum strain on the cables. In order that the system may be easily re-routed, or damaged sections quickly replaced, free access to the cable should be ensured and where possible, it is important to leave draw cords in ducting, piping etc, for future use.

4.2.1.1 *Improvement areas*

- a) *Do not exceed the maximum tensile load* — On runs from 40 m to 100 m, use proper lubricants and make sure they are compatible with the cable jacket. On runs over 100 m, use proper lubricants and pull from the middle out to both ends. If possible, use an automated puller with tension control or at least a breakaway-pulling eye.
- b) *Maintaining minimum bending radius* — Sharp bends in the cable may damage the insulating material, thus causing unacceptable losses in the transmission medium. Therefore, the internal radius of every bend in a cable shall be such as not to cause damage to the cable, nor impair the characteristics of the cable.
- c) *Proper cable slack at outlet points and patch panels* — Install the system such that sufficient slack remains to enable re-termination of the outlets, a minimum of twice, and a limited scope for movement of the cabinets.
- d) *Patch panels and cable management* — Where possible, patch panels shall be installed within the communications units from the top, continuing downwards.
- e) *Electromagnetic compatibility (EMC)* — As a passive medium, structured cabling need not comply with the EMC regulations. However, telecom designers should be aware that cabling, when connected to transmission

equipment, could radiate, receive and conduct electromagnetic disturbances and act accordingly. When crossing mains cables, this shall be done at right angles.

- f) *Maintaining proper cable routes* — Cable shall not be routed over pipes, conduits, other cabling, ceiling tiles, etc, but shall rest directly on the supporting surface so as to minimize the potential for sharp bends, kinks, etc. Every cable used shall be supported in such a way that it is not exposed to undue mechanical strain so that there is no appreciable mechanical strain on the terminations.
- g) *Labelling* — The cable shall be clearly labelled at both ends, as outlined in the documentation and/or drawing. Each 8P8C connector (information outlet) shall be individually labelled. The label shall contain a unique identification, as outlined in the documentation and/or drawing, and shall be indelible and placed behind a transparent cover. At the patch panels, each socket shall be labelled according to its corresponding outlet identification.

4.2.2 *Workplace Safety*

Following measures shall be ensured for workplace safety:

- a) To maintain work place safety, personal protective equipment (PPE) like protective clothing, helmets and goggles should be used to protect the personnel from injury or infection from hazards such as physical, electrical, heat, chemical and biohazards.
- b) Lighting in telecom spaces shall be provided in an adequate amount such that continuing work operations, routine observations, and the passage of employees can be carried out in a safe and healthful manner. Certain specific tasks in centres, such as splicing cable and the maintenance and repair of equipment frame line-ups, may require a higher level of illumination and adequate provisioning should be provided for the purpose.
- c) While working with optical fibre installation, the real issue of eye safety is getting fibre scraps into the eye. The broken ends of fibres and scraps of fibre created during the termination and splicing may also be dangerous. Therefore, protective eyewear such as safety glasses should be worn by personnel while carrying out splicing and termination operations. Further, fibre optic splicing and termination use various chemical cleaners and adhesives as part of the processes. Therefore, careful handling

of fibre, cleaner and adhesive shall be ensured by the use of safety gloves and respiratory masks.

5 OTHER APPLICATIONS IN TELECOM INFRASTRUCTURE CABLING

5.1 Electronic Access Control (EAC)

EAC is important for overall personal safety and the protection of physical and intellectual property. EAC devices can include locks, integrated electronic devices controlling a single door or room, or a complex system of interconnected electronic devices controlling a zone, building, or campus. Access to private or secured spaces can be controlled in a great variety of methods. In addition, the user often has multiple levels of access required within a space. Personnel may have access to any given number of these. This access level may be required to change during the course of the day, week, or month. In contrast to a lock-and-key system, a modern computer-supported control system can meet these and many other user goals. This system employs programmable EAC. Time-of-day and day-of-the-week access levels can be applied to all personnel who have authorized entry. Additional precautions should be taken against weaknesses in the EAC system (for example, piggybacking, tailgating, unauthorized entry). A great number of possibilities exist from the passive

card to biometrics and any combination in between. A user may issue smart cards.

A typical EAC cable consists of four individually shielded pairs that are used for the door strike, card reader, door contact, and request for exit. The four individual wire pairs may be supplied individually or in a group. Coloured foil shields or jacket colours may be used to designate the intended purpose of each of the wire pairs within the cables.

In a shared communication environment, the EAC data travels along with other building systems and data networks packets on the same physical network. This is often accomplished through an ethernet connection. It may also use building automation networks. Another media for shared communication relies on a private branch exchange and local analog telephone line. *See Annex A for details.*

5.2 Video Surveillance

Video surveillance is the extension of human vision to areas requiring surveillance. Some primary applications of this technology include investigation, prosecution, deterrence, observation and intrusion detection. In addition to traditional capture devices that operate within the visible band of the electromagnetic spectrum, other technologies provide unique viewing capabilities using IR, thermal and film cameras. *See Annex A for details.*

ANNEX A

(Clauses 3.2.4, 3.2.4.1, 3.2.6, 5.1 and 5.2)

ADDITIONAL GUIDELINES FOR INFORMATION AND COMMUNICATION ENABLED INSTALLATIONS

A-1 GENERAL

This annex contains information which supplements the text of this Section. The information can be used to make decisions while exercising options from among various types of hardware, cables, etc, and also for guidance.

A-2 CONNECTORS AND CONNECTING HARDWARE

Various types of connecting hardware may be as described below.

A-2.1 Balanced Copper Twisted-Pair Connectors

- a) *Insulation displacement contact (IDC) connectors* — The insulation displacement contact (IDC) is a gas-tight physical contact

between two electrical conductors. The gas-tight contact is established by a cold weld with the elimination of the air gap between the conductor and the IDC and therefore the possibility of contact interface corrosion. Such contact creates a reliable, long-lasting connection with stable electrical properties. IDC connectors also eliminate conductor preparation (for example, insulation removal), reducing the termination time and the number of tools.

- b) *Modular plug* — Modular plugs have IDC contacts designed for either stranded or solid conductors as well as connectors having universal contacts that accept both stranded and solid conductors. Materials used to build

modular plugs are typically flame retardant polycarbonate (body) and phosphor bronze with gold plating over nickel in contact area (contacts).

- c) *Modular jack* — Modular jacks are available in various sizes and shapes (keyed and unkeyed). The number of positions indicates the connector’s width, while the number of contacts installed into the available positions indicates the maximum number of conductors the connector can terminate.

A-2.2 Optical Fibre Connectors

The most common optical fibre interfaces include,

- a) *LC connector* — It is a simplex connector that can be converted to a duplex using a clip. It is keyed, low-loss, pull-proof and wiggle-proof. It can be terminated in many different ways, including using anaerobic (quick cure) adhesive, cleave and crimp, and hot melt. This is often referred to as a small form factor (SFF) connector. The LC connector provides a pull-proof design and small size perfect for high-density applications. It is available in simplex or duplex versions. The LC connector is provided with a 1.25 mm ferrule. It also incorporates a unique latching mechanism providing stability in system rack mounts.
- b) *Subscriber connector (SC)* — It is a simplex connector that can be converted to a duplex using a clip. It is keyed, low-loss, pull-proof, and wiggle-proof. It can be terminated in many different ways, including using anaerobic (quick cure) adhesive, cleave and crimp, and hot melt. The SC connector is a snap-in connector that latches with a simple push-pull motion, with a 2.5 mm ferrule and is widely used for its excellent performance. It is also available in a duplex configuration.
- c) *Straight tip (ST) compatible* — It is a simplex connector. It is a keyed, low loss connector. It can be terminated many different ways, including using anaerobic (quick cure) adhesive, cleave and crimp and hot melt.
- d) *Splices (Optical fibre connectors)* — These are used for adding optical fibre cable lengths. There are two primary splicing methods for optical fibres, fusion and mechanical. Both methods are field proven and have excellent long-term reliability when completed according to the manufacturer’s instructions. Splices and stripped optical fibre cables are protected and secured by a splice enclosure. When a splice enclosure is used for splicing inside a building,

it is generally secured to a rack or wall. In both cases, the splice enclosure contains the optical fibre splices in splice trays or organizers, typically in groups of 6, 12, 24, or more optical fibres per splice tray or organizer.

A-2.3 Coaxial Connectors

Connectors are installed on the end of a coaxial cable to provide electrical and mechanical connection to a system component. Either male or female connectors can be attached to coaxial cable, but most installations use male connectors on cable ends.

There are many styles of coaxial cable connectors. Three popular styles are:

- a) BNC-style connector,
- b) F-style connector, and
- c) N-style connector.

A-2.4 Connecting Hardware

Cables are terminated in outlets in work areas or intermediate equipment through connecting hardware. Basic connecting hardware styles are:

- a) Telecom outlets/connectors, including multiuser outlets;
- b) Patch panels;
- c) Connecting (wiring) blocks;
- d) Cable assemblies;
- e) Optical distribution frames; and
- f) Splices.

To facilitate their installation, servicing, administration and maintenance, connecting hardware of different styles of connectors may be considered to be grouped in one unit. However, depending upon the given situation, one or more type of connecting hardware (copper pair, coaxial or optical) may be installed on separate panels/frames.

A-3 CLASSIFICATION OF CABLES BY FIRE SAFETY PROPERTIES

A-3.1 Twisted Pair Cables

Different communication cable types and their markings on cable sheath are as given below:

<i>Marking</i>	<i>Cable Type</i>
CMP	Communications plenum cable
CMR	Communications riser cable
CMG/CM	Communications general-purpose cable
CMX	Communications cable, limited use
CMUC	Under carpet communications wire and cable

A-3.1.1 Type CMP (Communications Plenum Cable)

Type CMP communications plenum cables are suitable for use in ducts and plenums and they have adequate fire-resistant and low smoke-producing characteristics.

A-3.1.2 Type CMR (Communications Riser Cable)

Type CMR communications riser cables are suitable for use in a vertical run in a shaft when penetrating one or more floors as they have fire-resistant characteristics and thus be capable of preventing the carrying of fire from floor to floor.

A-3.1.3 Type CMG/CM (Communications General-Purpose Cable)

Type CMG general-purpose communications cables are suitable for general-purpose communications use, with the exception of risers and plenums, and these cables are resistant to the spread of fire.

A-3.1.4 Type CMX (Communications Cable, Limited Use)

Type CMX limited-use communications cables are suitable for use in dwellings and raceways as being resistant to flame spread.

A-3.1.5 Type CMUC (Under Carpet Communications Wire and Cable)

Type CMUC under carpet communications wires and cables are suitable for under carpet use and they are resistant to flame spread.

A-3.2 Optical Fibre Cables

Different optical fibre cable types and their markings on cable are as given below:

Marking	Cable Type/Suitability
OFNP	Non-conductive optical fibre plenum cable
OFCP	Conductive optical fibre plenum cable
OFNR	Non-conductive optical fibre riser cable
OFNR	Conductive optical fibre riser cable
OFNG	Non-conductive optical fibre general-purpose cable
OFNG	Conductive optical fibre general-purpose cable
OFN	Non-conductive optical fibre general-purpose cable
OFC	Conductive optical fibre general-purpose cable

A-3.2.1 Types OFNP and OFCP

Types OFNP and OFCP non-conductive and conductive optical fibre plenum cables are suitable for use in ducts

and plenums and they have adequate fire-resistant and low smoke-producing characteristics.

A-3.2.2 Types OFNR and OFCR

Types OFNR and OFCR non-conductive and conductive optical fibre riser cables are suitable for use in a vertical run in a shaft when penetrating one or more floors and have the fire-resistant characteristics capable of preventing the carrying of fire from floor to floor.

A-3.2.3 Types OFNG and OFCG

Types OFNG and OFCG non-conductive and conductive general-purpose optical fibre cables are suitable for general-purpose use, with the exception of risers and plenums, and these cables are resistant to the spread of fire.

A-3.2.4 Types OFN and OFC

Types OFN and OFC non-conductive and conductive optical fibre cables are suitable for general-purpose use, with the exception of risers and plenums and have resistance to the spread of fire.

A-4 BALANCED TWISTED-PAIR CABLE NOMENCLATURE

Details of nomenclatures of twisted pair cables using various combinations of overall screen type and individual pair screen type, as follows, are given in Table 2:

Overall Screen Type (x)	Individual Pair Screen Type (y)
Overall screen absent (U)	Individual screens absent (U)
Overall foil screen (F)	Individual foil screens (F)
Overall braid screen (S)	
Dual overall screen (SF) (foil + braid)	

A-5 ELECTRONIC ACCESS CONTROL (EAC) AND VIDEO SURVEILLANCE

A-5.1 Electronic Access Control (EAC)

An EAC system allows several levels of security. Once the number and type of people are determined, a user or access level for each person is established. Access levels are incorporated into the system integration and the areas of access are determined. Factors affecting the user level include security clearances, job title, rank, short-term employee and employee type. The access level is determined by the physical layout of building and is directly related to the doors and other portals it controls.

Table 2 Balanced Cable Nomenclature

(Clause A-4)

SI No.	Global Abbreviations (x/y)	North American Abbreviation	Overall Braid Screen	Overall Foil Screen	Individual Foil Screen
(1)	(2)	(3)	(4)	(5)	(6)
i)	U/U TP	U TP	No	No	No
ii)	U/F TP	S TP	No	No	Yes
iii)	F/U TP	F TP, ScTP, PiMF	No	Yes	No
iv)	F/F TP	S TP, SS TP	No	Yes	Yes
v)	S/U TP	S TP	Yes	No	No
vi)	S/F TP	S TP, SS TP	Yes	No	Yes
vii)	SF/U TP	S TP, SS TP	Yes	Yes	No
viii)	SF/F TP	S TP, SS TP	Yes	Yes	Yes

NOTE — The abbreviations represent as follows:

- a) F/F TP — Foil-screened foil-screened twisted-pair (Individually foil-screened twisted-pair in overall foil screen).
- b) F/U TP — Foil-screened unscreened twisted-pair (Unscreened twisted-pair in overall foil screen).
- c) S/F TP — Braid-screened foil-screened twisted-pair (Individually foil-screened twisted-pair in overall braid screen).
- d) S/U TP — Braid-screened unscreened twisted-pair (Unscreened twisted-pair in overall braid screen).
- e) Sc TP — Screened twisted-pair.
- f) SF/F TP — Braid-screened-foil-screened foil-screened twisted-pair (Individually foil-screened twisted-pair in overall foil and braid screen).
- g) SF/U TP — Braid-screened-foil-screened unscreened twisted-pair (Unscreened twisted-pair in overall foil and braid screen).
- h) U/F TP — Unscreened foil-screened twisted-pair (Individually foil-screened twisted-pair).
- j) U/U TP — Overall unshielded twisted-pair with unshielded twisted-pair.

The basic components of an EAC system include,

- a) a computer,
- b) one or more control panels, and
- c) one or more peripheral devices connected to the control panels (for example, card reader, siren and sensor).

The host computer runs the EAC software, manages the system parameters, maintains the system database, and controls all communication with the control panels. The host computer receives all event and alarm transactions from the control panels. It then saves them into separate history files that may be used to run reports by specific criteria.

The control panels manage the activation of peripheral devices by turning the devices on or off and controlling access to certain areas through card readers and door-locking hardware.

Media for communications may include the following:

- 1) *Balanced twisted-pair* — Shielded twisted-pair, unshielded twisted-pair, and screened twisted-pair.

- 2) *Optical fibre* — Multi-mode and single-mode.
- 3) *Wireless* — Microwave, radio frequency (RF), and infrared (IR).
- 4) Cellular networks connection.

A-5.2 Video Surveillance

A-5.2.1 In addition to traditional capture devices that operate within the visible band of the electromagnetic spectrum, other technologies that provide unique viewing capabilities are, as follows:

- a) *IR cameras* — These refer to specially designed imagers capable of seeing into the low IR bandwidth. They are sometimes referred to as starlight cameras because of their night time viewing capabilities.
- b) *Thermal cameras* — They capture heat or temperature values of a scene rather than light values, regardless of how bright or dark the scene appears to the human eye. Although the identification of colours and details are impossible with thermal cameras (because they only view temperature), these cameras are quite useful in viewing dark scenes for activities that have heat signatures.
- c) *Film cameras* — They have been on the market for many years. These self-sustaining units are equipped with traditional camera film, which permanently stores the scenes. The film requires replacement when exhausted.

A-5.2.2 Camera placement is based on security objectives identified through a need-assessment. Video surveillance applications include two typical types of camera mounts, as follows:

- a) *Fixed* — It refers to a camera dedicated to single view that does not change unless the camera is physically moved.
- b) *Pan and tilt* — It refers to a camera with a pan and tilt that allows for a 180° or 360° view, which is controlled electronically from a remote viewing station.

From a practical standpoint, the trade-off between the two types is that a pan and tilt provides a more flexible area of coverage at a higher cost than a fixed camera. Pan and tilt technology allows for auto-panning where the camera moves in a predefined cycle. Camera mounting locations are typically dictated by the available physical infrastructure and are balanced against the required field of views. Connectivity of cameras to the main system in a building environment is generally through coaxial cables.

LIST OF STANDARDS

The following list records those standards which are acceptable as 'good practice' and 'accepted standards' in the fulfilment of the requirements of the Code. The latest version of a standard shall be adopted at the time of enforcement of the Code. The standards listed may be used by the Authority for conformance with the requirements of the referred clauses in the Code.

In the following list, the number appearing in the first column within parantheses indicates the number of reference in this Section.

<i>IS No.</i>	<i>Title</i>
(1) 9537 (Part 2) : 1983	Specification for conduits for electrical installations: Part 2
(2) 9537 (Part 3) : 1983	Rigid steel conduits Specification for conduits for electrical installations: Part 3 Rigid plain conduits for insulating materials
3419 : 1989	Specification for fittings for rigid non-metallic conduits (<i>second revision</i>)
(3) 9537 (Part 5) : 2000	Specification for conduits for electrical installations: Part 5 Pliable conduits of insulating materials

NATIONAL BUILDING CODE OF INDIA

PART 9 PLUMBING SERVICES (INCLUDING SOLID WASTE MANAGEMENT)

Section 1 Water Supply

BUREAU OF INDIAN STANDARDS

CONTENTS

FOREWORD	...	3
1 SCOPE	...	5
2 TERMINOLOGY	...	5
3 GENERAL	...	9
4 WATER SUPPLY	...	11
ANNEX A APPLICATION FORM FOR TEMPORARY/PERMANENT SUPPLY OF WATER/FOR ADDITIONS AND/OR ALTERATIONS FOR SUPPLY OF WATER	...	41
ANNEX B FORM FOR LICENSED/REGISTERED PLUMBER'S COMPLETION CERTIFICATE	...	42
ANNEX C NOMOGRAM OF HAZEN AND WILLIAM'S EQUATION	...	43
LIST OF STANDARDS	...	44

FOREWORD

This Code (Part 9/Section 1) covers the requirements of water supply in buildings. The water supply provisions covered in this Section encompass the requirements of water supply, plumbing connected to public water supply, design of water supply systems, principles of conveyance and distribution of water within the premises, hot water supply system, inspection and maintenance of water supply systems. It also covers design of water supply systems in high altitudes and/or sub-zero temperature regions.

In the first version of the Code formulated in 1970, three separate sections of Part 9 Plumbing Services were brought out, namely, Section 1 Water supply, Section 2 Drainage and sanitation, and Section 3 Gas supply. These sections were subsequently revised in 1983. The major changes incorporated in the first revision in Section 1 Water supply, were: rationalization of definitions and addition of definitions for more terms; addition of universal pipe friction diagram and nomogram of Hazen and Willam's equation for discharge computation, deleting the discharge curves based on Chezy's formula; introduction of a detailed clause giving guidance on the design of water supply system for multi-storeyed buildings; modification to indicate that no separate storage need be provided for flushing and domestic purposes for health reasons and a single storage tank may be provided; modification/amplification of provisions relating to domestic hot water supply installations; introduction of a detailed clause covering recommendations to be considered while planning and designing water supply systems peculiar to high altitude and/or sub-zero temperature regions of the country; and addition of requirements relating to inspection, testing and maintenance applicable to hot water supply system.

As a result of experience gained in implementation of 1983 version of the Code and feedback received as well as revision of some of the standards based on which this Section was formulated, a need to revise this Section was felt. The last revision was therefore formulated to take care of these. In the last revision, the erstwhile two sections were merged and a combined and comprehensive Section, namely Section 1 Water supply, drainage and sanitation (including solid waste management), was brought out. Gas supply was brought out as Section 2. Following significant changes were incorporated in the last revision of Section 1 on water supply, drainage and sanitation, in respect to water supply: modification of provision of water supply requirement; addition of a new clause on water supply for other than residential purposes; addition of a new clause on quality of water, also including therein a sub-clause on waste water reclamation; modification of the provision regarding storage of water and introduction of guidelines for calculating storage capacity; modification, in the design of distribution system provisions for discharge computation, to include designed consumer pipes based on fixtures unit also taking into account probable simultaneous demand instead of earlier computation based on Reynold's Number; introduction of an alternative option of variable speed drive pumping system to hydro pneumatic system; addition of a new clause on backflow prevention; addition of provision for suitability of galvanized mild steel tanks on the basis of pH of the water; detailing of types of hot water heater; and restructuring of the section was done to make it more user friendly.

The last revision also incorporated for the first time the provisions on solid waste management.

In this revision, to address the various and distinct features related to the plumbing aspects and solid waste management comprehensively, this Part 9 has been rearranged as follows:

- | | |
|-----------|-------------------------|
| Section 1 | Water supply |
| Section 2 | Drainage and sanitation |
| Section 3 | Solid waste management |
| Section 4 | Gas supply |

Further, in this revision of the Section 1, the following significant changes/modifications have been incorporated:

- 1) Provisions on water supply requirements for buildings have been related to the estimated occupancy in the chosen type of building.
- 2) Table 1 on water requirements for buildings other than residences has been updated with respect to type

of buildings and it now also includes domestic and flushing requirements separately.

- 3) Water demand for landscaping purposes has been included.
- 4) Requirements related to treatment of waste water and usage of recycled waste water have been included.
- 5) Materials used for storage water tanks have been updated.
- 6) Provisions related to quantity of water to be stored have been updated.
- 7) Provisions have been included for protection of water supply by avoiding cross-connection between treated and raw water supplies and back flow prevention, and securing identification of non-potable water supply pipes.
- 8) List of materials used to manufacture pipes has been updated.
- 9) General requirements for design of distribution systems have been included.
- 10) Table 2 on fixture unit for different types of fixtures has been updated.
- 11) Table 3 on probable simultaneous demand has been updated with demand values included various intermediate and up to 10 000 fixture units, along with graphs for probable demand.
- 12) Maximum flow rate and flush volumes have been included.
- 13) Provisions related to inadequate and excessive water pressure have been included.
- 14) Guidance on water hammer effects have been included.
- 15) Provisions for distribution systems in multi-storeyed buildings have been updated along with illustrations therefor.
- 16) Provisions related to zoning of distribution systems have been included.
- 17) Hot water supply systems have been included under the existing clause on hot water supply installations.
- 18) Detailed provisions related to swimming pools have been included.
- 19) Guidance on allowance for expansion of water pipes have been included.
- 20) A new clause on colour coding for different types of water pipes has been included.
- 21) Provisions have been reviewed and updated from the point of view of accessibility by elderly and persons with disabilities, also, in this context, duly giving cross-reference to 13 of Part 3 'Development Control Rules and General Building Requirements'.
- 22) Certain terminologies have been included and some have been updated.
- 23) Cross-references to Indian Standards have been updated.

This Section is largely based on the following Indian Standards:

IS 1172 : 1993	Code of basic requirements for water supply, drainage and sanitation (<i>fourth revision</i>)
IS 2065 : 1983	Code of practice for water supply in buildings (<i>second revision</i>)
IS 6295 : 1986	Code of practice for water supply and drainage in high altitudes and or sub-zero temperature regions (<i>first revision</i>)
IS 7558 : 1974	Code of practice for domestic hot water installations
IS 12183 (Part 1) : 1987	Code of practice for plumbing in multi-storeyed buildings : Part 1 Water supply

A reference to SP 35 : 1987 'Handbook on Water Supply and Drainage' may be useful, from where also, assistance has been derived.

All standards, whether given herein above or cross-referred to in the main text of this Section, are subject to revision. The parties to agreement based on this Section are encouraged to investigate the possibility of applying the most recent editions of the standards.

In the formulation of this Section, reference has also been made to the following:

International Plumbing Code 2015, International Code Council, and

Uniform Plumbing Code 2015, International Association of Plumbing and Mechanical Officials

For the purpose of deciding whether a particular requirement of this Section is complied with, the final value, observed or calculated, expressing the result of a test or analysis, shall be rounded off in accordance with IS 2 : 1960 'Rules for rounding off numerical values (*revised*)'. The number of significant places retained in the rounded off value should be the same as that of the specified value in this Section.

NATIONAL BUILDING CODE OF INDIA

PART 9 PLUMBING SERVICES (INCLUDING SOLID WASTE MANAGEMENT)

Section 1 Water Supply

1 SCOPE

1.1 This Code (Part 9/Section 1) covers the basic requirements of water supply for residential, business and other types of buildings, including traffic terminal stations. This Section also deals with general requirements of plumbing connected to public water supply and design of water supply systems along with general guidelines about expansion in piping systems, and swimming pools.

1.1.1 This Section does not take into consideration the requirements of water supply for industrial plants and processes, which have to be provided for separately. It also does not provide the requirements of water supply for other purposes, such as firefighting and street cleaning.

2 TERMINOLOGY

For the purpose of this Section, the following definitions shall apply in addition to the definitions given in accepted standards [9-1(1)].

2.1 Definitions Relating to Water Supply

2.1.1 Access Panel — A removable panel mounted in a frame, normally secured with screws and mounted in a wall or ceiling, to provide access to concealed valves or items which may require maintenance.

2.1.2 Air Gap, Water Distribution — Unobstructed vertical distance through the free atmosphere between the lowest opening from any pipe or faucet conveying water to a tank or plumbing fixture and flood level rim of the receptacle.

2.1.3 Air Valve — A valve that releases air from a pipeline automatically without loss of water, or introduce air into a line automatically if the internal pressure becomes less than that of the atmosphere.

2.1.4 Authority Having Jurisdiction — The authority which has been created by a statute and which for the purpose of administering the Code/Part may authorize a committee or an official to act on its behalf; hereinafter called the 'Authority'.

2.1.5 Available Head — The head of water available at the point of consideration due to mains' pressure or overhead tank or any other source of pressure.

2.1.6 Anti-Siphon — A device or mechanism to prevent siphonage.

2.1.7 Backflow

- a) The flow of water or other liquids, mixtures or substances into the distributing pipes of a system of supply of potable water from any source or sources other than its intended source.
- b) The flow of a liquid in a direction reverse of that intended.

2.1.8 Backflow Prevention Device — Any approved measure or fitting or combination of fittings specifically designed to prevent backflow or back siphonage in a water service.

2.1.9 Back Pressure Back Flow — Due to an increased pressure above the supply pressure, which may be due to pumps, other equipment, gravity or other source of pressure.

2.1.10 Back Siphonage — The flowing back of used, contaminated, or polluted water from a plumbing fixture or vessel into a water supply due to a reduced pressure in such pipe (*see* 2.1.7).

2.1.11 Barrel — This portion of a pipe in which the diameter and wall thickness remain uniform throughout.

2.1.12 Base — The lowest portion or lowest point of a stack of vertical pipe.

2.1.13 Bath Room Group — Group of fixtures consisting of water closet, lavatory, bath tub or shower and other fittings with a floor drain located together.

2.1.14 Bedding — The material on which the pipe is laid and which provides support for the pipe. Bedding can be concrete, granular material or the prepared trench bottom.

2.1.15 Chair — A bed of concrete or other suitable material on the trench floor to provide a support for the pipes at intervals.

2.1.16 Channel — The open waterway through which sewage, storm water or other liquid wastes flow at the invert of a manhole or an inspection chamber.

2.1.17 Communication Pipe — That part of a service pipe which vests in the water undertakes. It starts at the water main and terminate at a point which differs according to the circumstances of the case.

2.1.18 Consumer — Any person who uses or is supplied

water or on whose application such water is supplied by the Authority.

2.1.19 Consumer's Pipe — The portion of service pipe used for supply of water and which is not the property of the Authority (see Fig. 1).

2.1.20 Cover

- a) A removable plate for permitting access to a pipe, fitting, vessel or appliance.

- b) The vertical distance between the top of the barrel of a buried pipe or other construction and the surface of the ground.

2.1.21 Cross-Connection — A connection between two normally independent pipelines which permits flow from either pipeline into the other.

2.1.22 Direct Tap — A tap which is connected to a supply pipe and is subject to pressure from the water main.

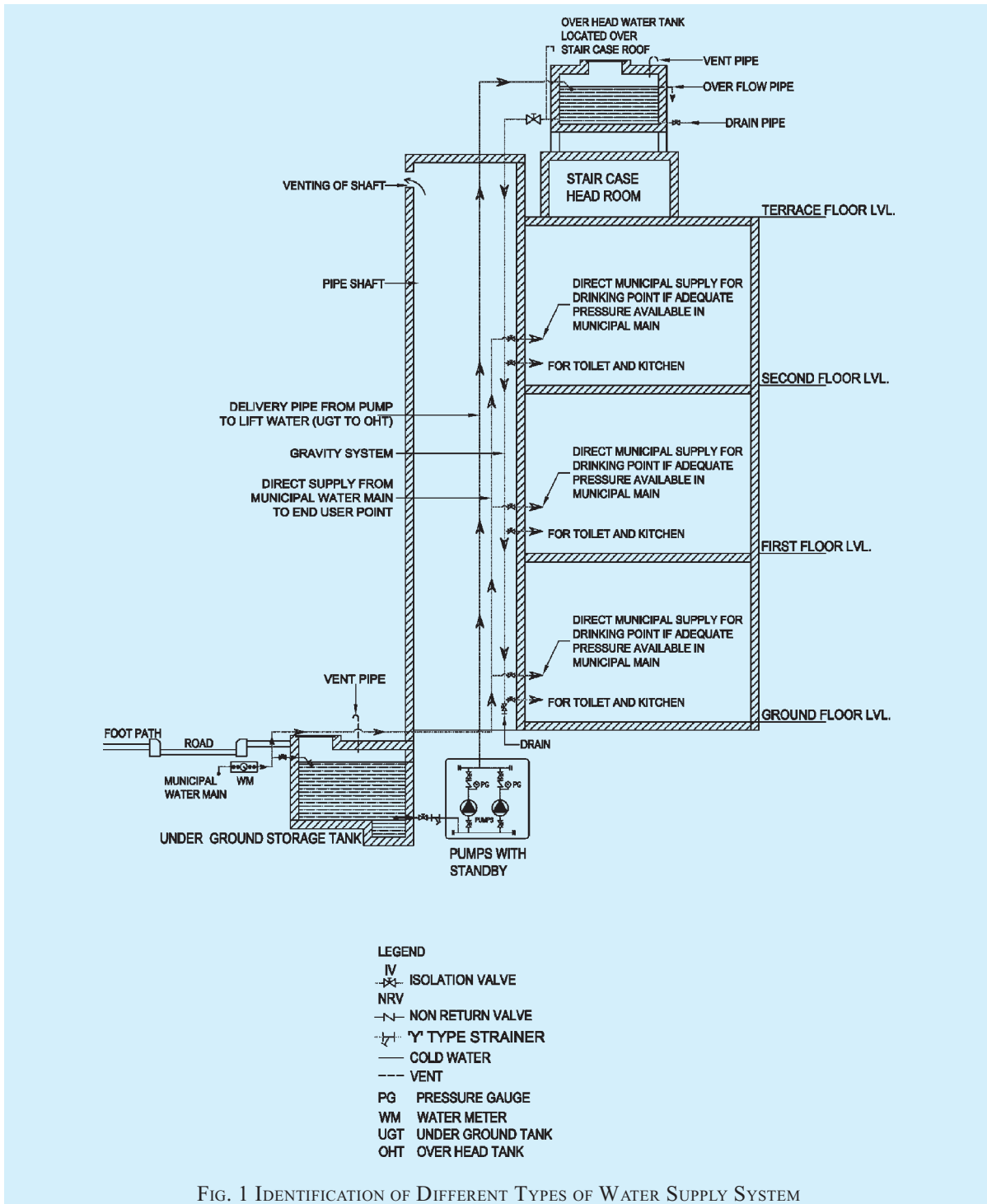

FIG. 1 IDENTIFICATION OF DIFFERENT TYPES OF WATER SUPPLY SYSTEM

2.1.23 Down Take Tap — A tap connected to a system of piping not subject to water pressure from the water main.

2.1.24 Effective Opening — The minimum cross-sectional area at the point of water supply, measured or expressed in terms of,

- a) the diameter of a circle; and
- b) the diameter of a circle of equivalent cross-sectional area, if the opening is not circular.

2.1.25 Feed Cistern — A storage vessel used for supplying cold water to a hot water apparatus, cylinder or tanks.

2.1.26 Fittings — The appurtenances such as coupling, flange, branch, bend, tees, elbows, unions, waste (with or without plug), P or S trap (with or without vent), stop ferrule, bib tap, pillar tap, bath faucet, water meter, garden hydrant, valves and any other article used in connection with water supply, drainage and sanitation.

2.1.27 Fixture Unit — A quantity in terms of which the load producing effects on the plumbing system of different kinds of plumbing fixtures is expressed on some arbitrarily chosen scale.

2.1.28 Float Operated Valve — Ball valves or ball taps and equilibrium valves operated by means of a float.

2.1.29 Flushing Cistern — A cistern provided with a device for rapidly discharging the contained water and used in connection with a sanitary appliance for the purpose of cleaning the appliance and carrying away its contents into a drain.

NOTE — The nominal size of a cistern is the quantity of water discharged per flush.

2.1.30 Flushometer Tank — A tank integrated with an air accumulator vessel that is designed to discharge a predetermined quantity of water to fixtures for flushing purposes.

2.1.31 Formation — The finished level of the excavation at the bottom of a trench or heading prepared to receive the permanent work.

2.1.32 Frost Line — The line joining the points of greatest depths below ground level up to which the moisture in the soil freezes.

2.1.33 General Washing Place — A washing place provided with necessary sanitary arrangement and common to more than one tenement.

2.1.34 Geysier — An apparatus for heating water with supply control on the inlet side and delivering it from an outlet.

2.1.35 Haunching — Outward sloping concrete support to the sides of a pipe or channel above the concrete bedding.

2.1.36 Heel Rest Bend or Duck-Foot Bend — A bend, having a foot formed integrally in its base, used to receive a vertical pipe.

2.1.37 High Altitudes — Elevations higher than 1 500 m above mean sea level (MSL).

2.1.38 Highway Authority — The public body in which is vested, or which is the owner of, a highway repairable by the inhabitants collectively; otherwise the body or persons responsible for the upkeep of the highway.

2.1.39 Horizontal Pipe — Any pipe of fitting which makes an angle of more than 45° with the vertical.

2.1.40 Hot Water Tank — A vessel for storing hot water under pressure greater than atmospheric pressure.

2.1.41 Hydro-Pneumatic System — The water supply pumping system which operates automatically in conjunction with pump(s), pressure vessel and pressure switch.

2.1.42 Junction Pipe — A pipe incorporating one or more branches.

2.1.43 Lagging — Thermal insulation or pipes.

2.1.44 Licensed (or Registered) Plumber — A person licensed (or registered) under the provisions of this Code.

2.1.45 Offset — A pipe fitting used to connect two pipes whose axes are parallel but not in line.

2.1.46 Period of Supply — The period of the day or night during which water supply is made available to the consumer.

2.1.47 Pipe Work — Any installation of piping with its fittings.

2.1.48 Plumbing

- a) The pipes, fixtures and other apparatus inside a building for bringing in the water supply and removing the liquid and water borne wastes.
- b) The installation of the foregoing pipes, fixtures and other apparatus.

2.1.49 Plumbing System — The plumbing system shall include the water supply and distribution pipes; plumbing fittings and traps; soil, waste, vent pipes and anti-siphonage pipes; building drains and building sewers including their respective connections, devices and appurtenances within the property lines of the premises; and water-treating or water-using equipment.

2.1.50 Potable Water — Water which is satisfactory for drinking, culinary and domestic purposes and meets the requirements of the Authority.

2.1.51 Premises — Premises shall include passages, buildings and lands of any tenure, whether open or enclosed, whether built on or not, and whether public or private in respect of which a water rate or charge is payable to the Authority or for which an application is made for supply of water.

2.1.52 Pressure Balancing Valve — Mixing valve that senses incoming hot and cold water pressures and compensates for fluctuations.

2.1.53 Residual Head — The head available at any particular point in the distribution system.

2.1.54 Residual Pressure — The pressure available at the fixture after allowance is made for pressure drop due to friction loss and head in the system during maximum demand periods.

2.1.55 Saddle — A purpose made fitting, so shaped as to fit over a hole cut in a sewer or drain used to form connections.

2.1.56 Service Pipe — Pipe that runs between the distribution main in the street and the riser in case of a multi-storeyed building or the water meter in the case of an individual house and is subject to water pressure from such main.

2.1.57 Static Pressure — The pressure exerted by a fluid that is not moving or flowing.

2.1.58 Stop-Cock — A cock fitted in a pipe line for controlling the flow of water.

2.1.59 Stop Tap — Stop tap includes stop-cock, stop valve or any other device for stopping the flow of water in a line or system of pipes at will.

2.1.60 Storage Tank — A container used for storage of water which is connected to the water main or tubewell by means of supply pipe.

2.1.61 Studio Apartment— An apartment unit consisting of a single room and a bathroom, the single room functioning as living room, bedroom and kitchen.

2.1.62 Subsoil Water— Water occurring naturally in the subsoil.

2.1.63 Subsoil Water Drain

- a) A drain intended to collect and carry away subsoil water.
- b) A drain intended to disperse into the subsoil from a septic tank.

2.1.64 Sub-Zero Temperature Regions — Regions where temperatures fall below 0°C and freezing conditions occur.

2.1.65 Supply Pipe — So much of any service pipe as is not a communication pipe.

2.1.66 Supports — Hangers and anchors or devices for supporting and securing pipe and fittings to walls, ceilings, floors or structural members.

2.1.67 Surface Water — Natural water from the ground surface, paved areas and roofs.

2.1.68 Surface Water Drain — A drain conveying surface water including storm water.

2.1.69 Thermostatic/Pressure Balancing Valve— Mixing valve that senses outlet temperature and incoming hot and cold water pressure and compensates for fluctuations for stabilization.

2.1.70 Vertical Pipe – Any pipe or fitting which is installed in a vertical position or which makes an angle or not more than 45° with the vertical.

2.1.71 Warning Pipe — An overflow pipe so fixed that its outlet, whether inside or outside a building, is in a conspicuous position where the discharge of any water there from can be readily seen.

2.1.72 Wash-Out Valve — A device located at the bottom of the tank for the purpose of draining a tank for cleaning, maintenance, etc.

2.1.73 Water Hammer Arrestor — A device designed to provide protection against hydraulic shock in the building water supply system.

2.1.74 Water Main (Street Main) — A pipe laid by the water undertakers for the purpose of giving a general supply of water as distinct from a supply to individual consumers and includes any apparatus used in connection with such a pipe.

2.1.75 Water Outlet — A water outlet, as used in connection with the water distributing system, is the discharge opening for the water: (a) to a fitting; (b) to atmospheric pressure (except into an open tank which is part of the water supply system); and (c) to any water-operated device or equipment requiring water to operate.

2.1.76 Water Supply System — Water supply system of a building or premises consists of the water service pipe, the water distribution pipes, and the necessary connecting pipes, fittings, control valves, and all appurtenances in or adjacent to the building or premises.

2.1.77 Waterworks — Waterworks for public water supply include a lake, river, spring, well, pump with or without motor and accessories, reservoir, cistern, tank, duct whether covered or open, sluice, water main, pipe, culvert, engine and any machinery, land, building or a thing used for storage, treatment and supply of water.

2.2 Definitions Relating to Swimming Pool

2.2.1 Appurtenance — An accessory facility or feature at a swimming pool, such as a diving board, slide, wading pool, plunge pool, spray pool.

2.2.2 Bather Load — The maximum number of persons that may be allowed in the pool area at one time without creating undue health or safety hazards.

2.2.3 Deep Area — An area of a swimming pool in which the water depth exceeds 1.5 m.

2.2.4 Diving Pool — A pool designed and intended for use exclusively for diving.

2.2.5 Inlet — An opening or fitting through which filtered water enters the pool.

2.2.6 Main Drain —The outlet or outlets for drain provided in the pool.

2.2.7 Make-Up Water — The water added to a pool to replace that which is lost.

2.2.8 Pool — A swimming pool or other recreational water basin utilized in conjunction with or as an appurtenance to a swimming pool.

NOTE — The term does not refer to spas and therapy pools not designed or intended for swimming or to basins for individual use that are drained after each use.

2.2.9 Pool Depth — The vertical distance between the pool floor and the water level.

2.2.10 Shallow Area — An area in a swimming pool, in which the water depth does not exceed 1.5 m at any point.

2.2.11 Skimmer — A mechanical device connected to the recirculation piping which is used to skim the pool surface.

2.2.12 Swimming Pool User Load — The number of bathers using the pool in a 24 h period for which a certain per capita capacity is often considered.

NOTE — The capacity of a swimming pool in terms of its user load is dictated by the capacity of water treatment equipment.

2.2.13 Transition Point — A location in a shallow area of a swimming pool where an area, having a floor slope of no more than 300 mm vertical in 3.65 m horizontal, adjoins an area where the floor slope exceeds 1 in 12.

2.2.14 Turnover Period — The time required to recirculate a volume of water equivalent to the water volume of the pool through the filtration system.

2.2.15 Wading Pool — A pool having a maximum water depth not exceeding 76 cm.

2.2.16 Water Level — The level of the overflow lip of a perimeter overflow system or the mid-level of surge weirs, if present, or the mid-level of the skimmer operating range.

2.2.17 Zero-Depth Edge — That portion of the perimeter of a zero-depth pool where the pool floor intersects the pool water surface.

2.2.18 Zero-Depth Pool — A swimming pool where the pool floor intersects the water surface along a portion of its perimeter.

3 GENERAL

3.1 Basic Principles

The design of water supply takes the following into consideration:

- a) Number of occupants;
- b) Minimum water requirements for different purposes;
- c) Treatment of water based on the quality of water;
- d) Quantity of water stored; and
- e) Sizing of pipes.

The basic principles of water supply, drainage and sanitation are given below, and the design of water supply should in general be guided by the applicable principles.

3.1.1 Potable Water

All premises intended for human habitation, occupancy, or use shall be provided with supply of potable water. This water supply shall not be connected with unsafe water resources, nor shall it be subject to the hazards of backflow.

3.1.2 Water Provision

Plumbing fixtures, devices and appurtenances shall be provided with water in sufficient volume and at pressures adequate to enable them to function properly and without undue noise under normal conditions of use.

There should be at least a residual head of 0.018 N/mm² at the consumer's tap. There may be certain fixtures or appliances in the installation that may require a higher pressure, such as 0.05 N/mm² or even higher (such as 0.1 N/mm² in case of flush valves), in which case the system shall be designed using pumps, tanks or both to achieve the required minimum pressure.

NOTE — The residual head shall be taken at the highest/farthest outlets in the building.

3.1.3 Water Efficiency

Plumbing system shall be designed, installed and adjusted to use the optimum quantity of water consistent with proper performance and cleaning.

3.1.4 Safety Devices

Plumbing system shall be designed and installed with safety devices to safeguard against dangers from contamination, explosion, overheating, etc.

3.1.5 Minimum Water Amenities

It is recommended that each dwelling unit should have at least one water closet, one lavatory, one kitchen wash place or a sink, and one bathing place or shower to meet the basic requirements of sanitation and personal hygiene.

In case of a group housing, the requirements relating to toilet or sanitary room and kitchen as given in **13** and **B-9** of Part 3 'Development Control Rules and General Building Requirements' of the Code shall also be complied with.

3.1.6 Drainage System

The drainage system shall be designed, installed and maintained to guard against fouling, deposit of solids and clogging and with adequate cleanouts so arranged that the pipes may be readily cleaned.

3.1.7 Materials and Workmanship

The plumbing system shall have durable material, free from defective workmanship and so designed and installed as to give satisfactory service for its reasonable expected life. The accessories of the plumbing system should be of such specifications as to meet the functional requirements of the installation, so as to also avoid any inconsistency leading to leakage and resultant seepage.

3.1.8 Fixture Traps and Vent Pipes

Each fixture directly connected to the drainage system shall be equipped with a liquid seal trap. Trap seals shall be maintained to prevent sewer gas, other potentially dangerous or noxious fumes, or vermin from entering the building. Further, the drainage system shall be designed to provide an adequate circulation of air in all pipes with no danger of siphonage, aspiration, or forcing of trap seals under conditions of ordinary use by providing vent pipes throughout the system.

3.1.9 Foul Air Exhaust

Each vent terminal shall extend to the outer air and be so installed as to minimize the possibilities of clogging and the return of foul air to the building, as it conveys potentially noxious or explosive gases to the outside atmosphere. All vent pipes shall be provided with a cowl.

3.1.10 Testing

The plumbing system shall be subjected to required tests to effectively disclose all leaks and defects in the work or the material.

3.1.11 Exclusion from Plumbing System

No substance that will clog or accentuate clogging of pipes, produce explosive mixtures, destroy the pipes or their joints, or interfere unduly with the sewage-disposal process shall be allowed to enter the drainage system.

3.1.12 Light and Ventilation

Wherever water closet or similar fixture is located in a room or compartment, it should be properly lighted and ventilated.

3.1.13 Individual Sewage Disposal Systems

If water closets or other plumbing fixtures are installed in buildings where connection to public sewer is not possible, suitable provision shall be made for acceptable treatment and disposal.

3.1.14 Maintenance

Plumbing systems shall be maintained in a safe and serviceable condition.

3.1.15 Approach for Use and Cleaning

All plumbing fixtures shall be so installed with regard to spacing as to be approachable for their intended use and for cleaning. All doors, windows and any other device needing access within the toilet shall be so located that they have proper approach.

3.1.16 Accessibility for Persons with Disabilities

All doors, windows and fixtures, including WC, urinals, grab bars, washbasin, mirror and all other accessories for use by persons with disabilities shall be so installed/ located that they have proper access with appropriate width, height, space, centerlines, and ease of operation (*see 13* of Part 3 'Development Control Rules and General Building Requirements' of the Code).

3.1.17 Structural Safety

Plumbing system shall be installed with due regard to preservation of the structural members and prevention of damage to walls and other surfaces.

3.1.18 Protection of Ground and Surface Water

Sewage or other waste shall not be discharged into surface or sub-surface water without acceptable form of treatment.

3.2 Water Supply Connection

3.2.1 Application for Obtaining Supply Connection

Every consumer, requiring a new supply of water or any extension or alteration to the existing supply shall apply in writing in the prescribed form (*see Annex A*) to the Authority.

3.2.2 Bulk Supply

In the case of large housing colonies or campuses, or where new services are so situated that it will be necessary for the Authority to lay new mains or extend an existing main, full information about the proposed scheme shall be furnished to the Authority. Information shall also be given regarding their phased requirements of water supply with full justification. Such information shall include site plans, showing the layout of roads, footpaths, building and boundaries and indicating thereon the finished line and level of the roads or footpaths and water supply lines and appurtenances.

3.2.3 Completion Certificate

On completion of the plumbing work for the water supply system, the licensed/registered plumber shall give a completion certificate in the prescribed form (*see Annex B*) to the Authority for getting the water connection from the mains.

3.3 Licensing/Registration of Plumbers

3.3.1 Execution of Work

The work which is required to be carried out under the provisions of this Section, shall be executed only by a licensed/registered plumber under the control of the Authority and shall be responsible to carry out all lawful directions given by the Authority. No individual shall engage in the business of plumbing unless so licensed/ registered under the provisions of this Section.

3.3.1.1 No individual, firm, partnership or corporation shall engage in the business of installing, repairing or altering plumbing unless the plumbing work performed in the course of such business is under the direct supervision of a licensed/registered plumber.

3.3.2 Examination and Certification

The Authority shall establish standards and procedure for the qualification, examination and licensing/registration of plumbers and shall issue licences to such persons who meet the qualifications thereof and successfully pass the examination.

3.3.3 For guidelines for registration of plumbers including the minimum standards for qualifications for the grant of licences/registration, reference may be made to good practice [9-1(2)]. The Authority may also utilize the services of the certified plumbers who are certified for the required skill level under the appropriate scheme of the Government.

4 WATER SUPPLY

4.1 Water Supply Requirements for Buildings

The total quantity of water per day is estimated based on the proposed occupancy and activities catered. Designer has to identify all the possible sources for augmenting the shortfall in water supply. The analysis of available water is done to decide the treatment for consumption and treatment process depends on the quality of water and the purpose for which it is used.

Projection of population for each building shall be made on the basis of its usage. Population for each type of building shall be estimated on the basis of information obtained from the users. Alternatively, population may be worked on the following basis, for different type of buildings:

a) *Residential buildings:*

<i>Accommodation</i>	<i>Population Requirements</i>
1 bedroom dwelling unit	4
2 bedroom dwelling unit	5
3 bedroom dwelling unit	6
4 bedroom dwelling unit and above	7

NOTES

- 1 The above figures consider a domestic household including support personnel, wherever applicable.
- 2 For plotted development, the population may be arrived at after due consideration of the expected number and type of domestic household units.
- 3 Dwelling unit under EWS category shall have population requirement of 4 and studio apartment shall have population requirement of 2.

b) *Other than residential buildings:*

<i>Occupancy</i>	<i>Population Requirement</i>
Offices	1 person per 10 m ² of floor area (<i>see</i> Note 1)
Schools	Strength of school + Teaching and non-teaching staff
Hostels	Number of beds + 4.5 x (warden's residence) + staff
Hotels	Number of beds + Staff + Requirement of restaurant seats
Hospitals	Number of beds + Staff + Patient attendants (generally population density per bed in secondary care hospital is 5, tertiary care is 7 and quaternary care is 9)
Mercantile	1 person per 3 m ² of street floor and sales basement areas + 1 person per 6 m ² of upper sale floors (Total population may be segregated into 10 percent for fixed and 90 percent for floating/visitors)
Traffic terminal stations	Average number of users per day (Total annual passenger traffic/365) + Staff + Vendors

NOTES

- 1 Wherever there are multiple work shifts, the number of users within a 24 h period may be considered as per actuals.
- 2 Population of 5 to 15 percent, depending on the usage of building, shall be considered for visitors and floating population likely to use the buildings facilities.

4.1.1 Water Supply for Residences

A minimum of 70 to 100 litre per head per day may be considered adequate for domestic needs of urban communities, apart from non-domestic needs as flushing requirements (which varies based on type of building occupancy). As a general rule the following rates per capita per day may be considered for domestic and non-domestic needs:

- a) For communities with population up to 20 000:
 - 1) Water supply through stand: 40 lphd (*Min*) post
 - 2) Water supply through house: 70 to 100 lphd service connection
- b) For communities with: 100 to 135 lphd population 20 000 to 100 000 together with full flushing system

- c) For communities with population: 150 to 200 lphd above 100 000 together with full flushing system

NOTE — The value of water supply given as 150 to 200 litre per head per day may be reduced to 135 litre per head per day for houses for Medium Income Group (MIG) and Lower Income Groups (LIG) and Economically Weaker Section of Society (EWS), depending upon prevailing conditions and availability of water.

4.1.1.1 Out of the 150 to 200 litre per head per day, 45 litre per head per day may be taken for flushing requirements and the remaining quantity for other domestic purposes.

4.1.2 *Water Supply for Buildings Other than Residences*

Minimum requirements for water supply for buildings other than residences shall be in accordance with Table 1.

Table 1 Water Requirements for Buildings Other than Residences
(Clause 4.1.2)

Sl No.	Type of Building	Domestic Per Day litre	Flushing Per Day litre	Total Consumption Per Day litre
(1)	(2)	(3)	(4)	(5)
i)	Factories including canteen where bath rooms are required to be provided	30 per head	15 per head	45 per head
ii)	Factories including canteen where no bath rooms are required to be provided	20 per head	10 per head	30 per head
iii)	Hospital (excluding laundry and kitchen) (<i>see</i> Note 2):			
	a) Number of beds not exceeding 100	230 per head	110 per head	340 per head
	b) Number of beds exceeding 100	300 per head	150 per head	450 per head
	c) Out patient department (OPD)	10 per head	5 per head	15 per head
iv)	Nurses' homes and medical quarters	90 per head	45 per head	135 per head
v)	Hostels	90 per head	45 per head	135 per head
vi)	Hotel (up to 3 star) excluding laundry, kitchen, staff and water bodies	120 per head	60 per head	180 per head
vii)	Hotel (4 star and above) excluding laundry, kitchen, staff and water bodies	260 per head	60 per head	320 per head
viii)	Offices (including canteen)	25 per head	20 per head	45 per head
ix)	Restaurants and food court including water requirement for kitchen:			
	a) Restaurants	55 per seat	15 per seat	70 per seat
	b) Food court	25 per seat	10 per seat	35 per seat
x)	Clubhouse	25 per head	20 per head	45 per head
xi)	Stadiums	4 per head	6 per head	10 per head
xii)	Cinemas, concert halls and theatres and multiplex	5 per seat	10 per seat	15 per seat
xiii)	Schools/Educational institutions:			
	a) Without boarding facilities	25 per head	20 per head	45 per head
	b) With boarding facilities	90 per head	45 per head	135 per head
xiv)	Shopping and retail (mall)			
	a) Staff	25 per head	20 per head	45 per head
	b) Visitors	5 per head	10 per head	15 per head
xv)	Traffic terminal stations (<i>see</i> Notes 3 and 4)			
	a) Airports	40 per head	30 per head	70 per head
	b) Railway stations (Junctions) with bathing facility	40 per head	30 per head	70 per head
	c) Railway stations (Junctions) without bathing facility	30 per head	15 per head	45 per head
	d) Railway Stations (Intermediate) with bathing facility	25 per head	20 per head	45 per head
	e) Railway Stations (Intermediate) without bathing facility	15 per head	10 per head	25 per head
	f) Interstate bus terminals	25 per head	20 per head	45 per head
	g) Intrastate Bus Terminals/Metro Stations	10 per head	5 per head	15 per head

NOTES

1 For calculating water demand for visitors, consumption of 15 litre per head per day may be taken.

2 The water demand includes requirement of patients, attendants, visitors and staff. Additional water demand for kitchen, laundry and clinical water shall be computed as per actual requirements.

3 The number of persons shall be determined by average number of passengers handled by stations, with due considerations given to the staff and vendors who are using these facilities.

4 Consideration should be given for seasonal average peak requirements.

5 The hospitals may be categorized as Category A (25 to 50 beds), Category B (51 to 100 beds), Category C (101 to 300 beds), Category D (301 to 500) and Category E (501 to 750 beds).

The water demand for the laboratory facilities will depend on actual requirements based on functional point of view.

4.1.3 Water Supply Requirements of Traffic Terminal Stations

The water supply requirements of traffic terminal stations (railway stations, bus stations, harbours, airports, etc) include provisions for waiting rooms and waiting halls. They do not, however, include requirements for retiring rooms. Requirements of water supply for traffic terminal stations shall be as per Table 1.

4.1.4 Water Supply for Fire Fighting Purposes

4.1.4.1 The Authority shall make provision to meet the water supply requirements for fire fighting in the city/area, depending on the population density and types of occupancy. *See also* Part 4 ‘Fire and Life Safety’ of the Code.

4.1.4.2 Provision shall be made by the owner of the building for water supply requirements for fire fighting purposes within the building, depending upon the height and occupancy of the building, in conformity with the requirements laid down in Part 4 ‘Fire and Life Safety’ of the Code.

4.1.4.3 The requirements regarding water supply in storage tanks, capacity of fire pumps, arrangements of wet riser-cum-down comer and wet riser installations for buildings, depending upon the occupancy use and other factors, shall be in accordance with Part 4 ‘Fire and Life Safety’ of the Code.

4.1.5 Water Supply for Other Purposes

4.1.5.1 Water supply in many buildings is also required for many other applications other than domestic use, which shall be identified in the initial stages of planning so as to provide the requisite water quantity, storage capacity and pressure as required for each application. In such instances information about the water use and the quality required may be obtained from the users. Some typical uses other than domestic use and fire fighting purposes are air conditioning, swimming pools and water bodies, and gardening. Treated water from sewage treatment plant, with suitable tertiary treatment, should be used for flushing purpose (with dual piping system), gardening purpose, cooling tower make up, and/or for other non potable usage.

4.1.5.2 The water demand for landscaping purposes is generally taken as 6 to 8 litre/m²/day for lawns. For shrubs and trees the above value can be reduced considerably.

4.2 Water Sources and Quality

4.2.1 Sources of Water

The origin of all sources of water is rainfall. Water can

be collected as it falls as rain before it reaches the ground; or as surface water when it flows over the ground or is pooled in lakes or ponds; or as ground water when it percolates into the ground and flows or collects as ground water; or from the sea.

Contamination of water supplies can occur in the source water as well as in the distribution system after water treatment has already occurred. There are many sources of water contamination, including naturally occurring chemicals and minerals (for example, arsenic, radon, uranium), local land use practices (fertilizers, pesticides, concentrated animal feeding operations), manufacturing processes, and sewer overflows or wastewater releases. The presence of contaminants in water can lead to adverse health effects, including gastrointestinal illness, reproductive problems, and neurological disorders.

4.2.2 The water supplied shall be free from pathogenic organisms, clear, free from undesirable taste and odour, neither corrosive nor scale forming and free from minerals which could produce undesirable physiological effects. The quality of water to be used for drinking shall be as per accepted standard [9-1(3)].

4.2.3 For purposes other than drinking water if supplied separately, shall be absolutely safe from bacteriological contamination so as to ensure that there is no danger to the health of the users due to such contaminants.

For purposes other than drinking, where there is an overall risk of legionella growth, it is advisable that for cold water supplies, the temperature does not exceed 20°C and a minimum temperature of 55°C for hot water supplies be maintained at all points of network so as to ensure that it is absolutely safe from bacteriological contamination and there is no danger to the health of the users due to such contaminants.

4.2.4 Waste Water Reclamation

Treated sewage or other waste water of the community may be utilized for non-domestic purposes such as water for flushing, landscape irrigation, cooling towers of HVAC system, in fountains and recreational lakes where swimming is not allowed, and for certain industrial purposes after its necessary treatment to suit the nature of the use. This supply system shall be allowed in residences only if proper provision is made to avoid any cross-connection of this treated waste water with domestic water supply system. During use of treated waste water, it is recommended to have dual piping system to avoid cross-contamination.

4.2.4.1 Treatment of waste water and usage of recycled water

Waste water is generated by residential and other establishments like institutional, business, mercantile

and industrial. It includes household waste liquid from toilets, baths, showers, kitchens and sinks that is disposed of *via* sewers. Waste water treatment is the process of removing contaminants from wastewater, including household sewage and runoff (effluents). It includes physical, chemical, and biological processes to remove contaminants. Treatment of waste water and usage of recycled waste water may be done to make it usable for appropriate applications. The objective is to produce an environmentally safe fluid waste stream (or treated effluent) and a solid waste (or treated sludge) suitable for disposal or reuse.

Separation of household waste into grey water and black water (and draining of black water into sewerage system) is becoming more common with grey water being permitted to be used for watering plants or recycled for flushing toilets after proper treatment. Waste water collection and treatment is typically subject to statutory regulations. Treatment depends on the characteristics of influent and the treatment requirements that are needed for treating the same. Waste water treatment generally involves the following three stages:

- a) *Primary treatment* — It consists of temporarily holding the wastewater for settlement of heavy solids at the bottom while oil, grease and lighter solids float to the surface.
- b) *Secondary treatment* — It removes dissolved and suspended biological matter.
- c) *Tertiary treatment* — It is more intensive treatment done in order to allow rejection into a highly sensitive or fragile ecosystem. The tertiary treatment is generally followed by disinfection.

4.2.5 Water Conservation, Water Balance and Use of Recycled Water

Water conservation encompasses the policies, strategies and activities to manage fresh water as a sustainable resource, to protect the water environment and to meet current and future demand. Population, household size, and growth and affluence all affect the quantity of water used. Water balance studies should be carried out to study the availability of water from different sources and its usage for different purposes.

4.2.6 Whenever a building is used after long intervals, the water quality of the stored water shall be checked so as to ensure that the water is safe for use as per water quality requirements specified in this Code.

4.3 Estimate of Demand Load

4.3.1 Estimates of total water supply requirements for buildings shall be based on the occupant load consistent with the provisions of 4.1.

4.3.2 In making assessment of water supply requirements of large complexes, the future occupant load shall be kept in view. The following methods may be used for estimating future requirements:

- a) Demographic method of population projection,
- b) Arithmetic progression method,
- c) Geometrical progression method,
- d) Method of varying increment or incremental increase,
- e) Logistic method,
- f) Graphical projection method, or
- g) Graphical comparison method.

4.4 Storage of Water

4.4.1 In a building, provision is required to be made for storage of water for the following reasons:

- a) To provide against interruptions of the supply caused by repairs to mains, etc;
- b) To reduce the maximum rate of demand on the mains;
- c) To tide over periods of intermittent supply; and
- d) To maintain a storage for the fire fighting requirement of the building

4.4.2 The water may be stored in overhead tanks (OHT) and/or underground tanks (UGT).

4.4.3 Materials Used

Reservoirs and tanks for the storage of water shall be constructed of reinforced concrete, brick masonry, ferrocement, mild steel, stainless steel, plastic or glass reinforced panels.

4.4.3.1 Tanks made of steel may be of welded, riveted or panel/pressed construction. The metal shall be galvanized or coated externally with a good quality anti-corrosive weather-resisting paint. Lead-based paint shall not be used in the tank. Lead-lined tanks shall not be used. Rectangular pressed steel tanks shall conform to good practice [9-1(4)].

4.4.4 Each tank shall be provided with the following:

- a) *Manholes* — Adequate number of manholes for access and repair. The manholes shall be made of corrosion resistant material (for example, cast iron, reinforced cement concrete, steel fibre reinforced concrete, galvanized steel, high density polyethylene, fibre glass reinforced plastic or such other materials) acceptable to the Authority. Manholes shall be provided with locking arrangement to avoid misuse and tampering.

- b) *Ladders* — Tanks higher than 900 mm deep shall be provided with corrosion resistant ladders according to the depth to enable a person to reach the bottom of the tank.
- c) *Overflow pipe* — Each tank shall be provided with an overflow pipe terminating above the ground/terrace level to act as a ‘Warning Pipe’ to indicate overflow conditions. The size of the overflow pipe shall be adequate to accept the flow. Normally the overflow pipe size shall be one size higher than the inlet pipe. When the inlet pipe diameter is large, two or more overflow pipes of equivalent cross-section may be provided.
- d) *Vent pipes* — Tanks larger than 5 000 litre capacity shall be provided with vent pipes to prevent development pressure in the tank which might result in ‘NO FLOW’ condition or inward collapse of the tank.
- e) *Scour pipe* — Each tank shall be provided with a scour pipe with an accessible valve for emptying the tank.
- f) *Connection of overflow and scour pipe* — Under no circumstances tank overflow and scour pipe shall be connected to any drain, gully trap or manhole to prevent back flow and contamination of the water. All such connections shall be discharged over a grating with an air gap of 50 mm. All overflow and vent pipes shall be provided with a mosquito proof brass grating to prevent ingress of mosquito, vermin and other insects.
- g) The top slab of the tank shall be suitably sloped away from its centre for proper drainage of the rainwater.
- h) Tanks on terraces and above ground shall be supported by appropriate structural members so as to transfer the load of the tank and the water directly on the structural members of the building.

4.4.5 Every storage tank shall be easily accessible and placed in such a position as to enable thorough inspection and cleaning to be carried out. If the storage capacity required is more than 5 000 litre, it is advantageous to arrange it in a series of tanks so interconnected that each tank can be isolated for cleaning and inspection without interfering with the supply of water. In large storage tanks, the outlet shall be at the end opposite the inlet to avoid stagnation of the water.

4.4.6 The outlet pipe shall be fixed 50 mm to 75 mm above the bottom of the tank and fitted with a strainer, preferably of brass.

4.4.7 In the case of underground storage tanks, the

design of the tank shall be such as to provide for the draining of the tank when necessary and water shall not be allowed to collect around the tank. The tank shall be perfectly water-proof and shall be provided with a cement concrete cover, having a manhole opening, with a properly fitting hinged cast iron cover on a leak-proof cast iron frame.

The underground tanks should not be located in low lying areas or near any public or private sewer, septic tank, leaching pool or soakage pit to prevent any contamination. The overflow of the tank should be well above (preferably 600 mm) the external surface level and terminate as a warning pipe with a mosquito proof grating. Care shall be taken to prevent backflow of local surface water into the tank in case of local flooding. Otherwise the overflow shall be terminated in a safer manner as per the site conditions. For tanks with at least one side exposed to a basement, it is safer to discharge the overflow into the basement level.

The tank top slab shall also be designed to carry the load due to fire tender movement where anticipated as in the case of an extended basement.

There should be no common wall between the tanks storing safe water and tanks storing water from unsafe sources.

4.4.8 In case of overhead tanks, bottom of the tanks shall be placed clear off the terrace slab such that the elevation difference between the outlet pipe of the tank and the highest fixture at the top floor of the building is minimum 2 m, which shall also prevent leakage into the structural slab. In tall buildings, the top of the tank shall be provided with the safe ladder or staircase. The top slab shall be provided with railing or a parapet wall.

4.4.9 For jointing steel pipe to a storage tank, the end of the pipe shall be screwed, passed through a hole in the tank and secured by backnuts, both inside and outside. The pipe end shall be flush with the face of the inside backnut. For jointing copper pipe to steel or copper tank, a connector of non-ferrous material shall be used. The connector shall have a shoulder to bear on the outside of the tank and shall be secured by a backnut inside.

4.4.10 The quantity of water to be stored shall be calculated taking into account the following factors:

- a) Hours of supply at sufficiently high pressure to fill up the overhead storage tanks;
- b) Frequency of replenishment of overhead tanks, during the 24 h;
- c) Rate and regularity of supply; and
- d) Consequences of exhausting storage particularly in case of public buildings like hospitals.

In case of intermittent water supply, the following guidelines should be adopted for calculation of capacity:

- 1) When the supply is from main OHT, the capacity of individual OHT may be taken as half a day demand.
- 2) In case of all the other buildings (apartments, hotels, hospitals, and commercial), the capacity of UGT and OHT may be taken as one and a half days and half a day demand. Wherever raw water and treated water are stored in separate UGTs, the combined storage capacity shall be of one and a half days demand.
- 3) In case of sewage treatment plant, for treated water storage in respect of flushing, one day flushing demand shall be stored in UGT or treated effluent storage tank which is part of the plant, and half a day demand shall be stored in OHT.

For additional requirement of water storage for fire fighting purposes, reference may be made to Part 4 'Fire and Life Safety' of the Code.

NOTE — Minimum requirements for calculation of capacity of these storage tanks are as follows:

- a) In case only OHT is provided, it may be taken as 33.33 to 50 percent of one day's requirement;
- b) In case only UGT is provided, it may be taken as 50 to 150 percent of one day's requirement; and
- c) In case combined storage is provided, it may be taken as 66.6 percent UGT and 33.33 percent OHT of one day's requirement.

4.4.11 Where the water supply distribution system is catering for separate potable water and flushing water supply, and where reclaimed or recycled treated water is being used within the building, it shall be considered as dual water supply system. In such cases, storages for flushing/reclaimed/recycled water shall be separated proportionately. Adequate measures and precautions shall be taken for physical segregation for sanitary purposes and to avoid cross-contamination in the distribution system and to prevent back contamination of water supply sources (*see 4.5*).

4.4.12 When only one communication pipe is provided for water supply to a building, it is not necessary to have separate storage for flushing and sanitary purposes for health reasons. In such cases when only one storage tank has been provided, tapping of water may be done at two different levels (the lower tapping for flushing) so that a part of the water will be exclusively available for flushing purposes.

4.5 Protection of Water Supply

4.5.1 General

The water supply system shall be designed, installed and maintained in such a manner so as to prevent

contamination from non-potable liquids, solids or gases being introduced into the potable water supply system through cross-connections or any other connection to the system.

4.5.2 Plumbing Fixtures

The water supply lines and fittings for plumbing fixtures shall be installed so as to prevent back flow and shall provide required back flow protections in accordance with **4.11**.

The devices, appurtenance intended for special function such as sterilization, processing, distillation, etc, shall be provided with back flow protection devices.

The water supply for hospital fixtures shall be protected against backflow with a reduced pressure principle back flow assembly, an atmospheric or spill resistant vacuum breaker assembly, or an air gap. Vacuum breakers for bed pan washer hoses shall not be located less than 1 525 mm above floor. Vacuum breakers for hose connections in health care or laboratory areas shall not be less than 1 800 mm above floor.

4.5.3 Cross-Connection Control

Cross-connections shall be prohibited, except where approved back flow prevention assemblies/devices are installed to protect the potable water supply (*see 4.11*).

Potable water outlets and combination stop and waste valves shall not be installed underground or below grade. Freeze proof yard hydrants that drain the riser into the ground are considered to be stop and waste valves.

Back flow prevention can be achieved by means of providing proper air gap, reduced pressure principle back flow prevention assemblies, back flow preventer with intermediate atmospheric vent, barometric loop, pressure vacuum breaker assemblies, atmospheric type vacuum breakers, double check back flow prevention assemblies, spill resistant pressure vacuum breaker, dual check back flow preventer, etc.

4.5.4 Identification of Non-Potable Water Systems

Where non-potable water systems are installed, the piping conveying the non-potable water shall be identified either by colour marking, metal tags or tapes in accordance with the relevant standards and good engineering practices.

4.6 Materials, Fittings and Appliances

4.6.1 Standards for Materials, Fittings and Appliances

All materials, water fittings and appliances shall conform to Part 5 'Building Materials' of the Code.

4.6.2 Materials for Pipes

Pipes may be of any of the following materials:

- a) Cast iron, vertically cast or centrifugally (spun) cast;
- b) Steel (internally lined or coated with bitumen or a bituminous composition, and out-coated with cement concrete or mortar, where necessary);

- c) Ductile iron, internally lined;
- d) Reinforced concrete;
- e) Prestressed concrete;
- f) Galvanized mild steel tubes;
- g) Copper;
- h) Brass;
- j) Wrought iron;
- k) Stainless steel;
- m) Polyethylene;
- n) Unplasticized PVC;
- p) Chlorinated PVC;
- q) Polypropylene-random copolymer (PPR);
- r) Composite pipes (PE-AL-PE) or any other combination;
- s) Cross-linked polyethylene (PEX); or
- t) Polybutylene pipe.

4.6.2.1 The material chosen shall be resistant to corrosion, both inside and outside or shall be suitably protected against corrosion.

4.6.2.2 Polyethylene and unplasticized PVC pipes shall not be installed near hot water pipes or near any other heat sources. For temperature limitations in the use of polyethylene and unplasticized PVC pipes to convey water, reference may be made to accepted standards [9-1(5)].

4.7 Design of Distribution Systems

4.7.1 General

For designing the distribution system, the following guidelines, in addition to those given in 4.7.2 to 4.7.6 shall be followed:

- a) All plumbing systems in buildings shall conform to the general requirements given in 3.1.
- b) Peak factor for calculation in case of intermittent flows may generally be adopted in design as 2 to 3.
- c) The residual head at consumer's tap shall be as per 3.1.2.

4.7.2 Rate of Flow

One of the important items that needs to be determined before the sizes of pipes and fittings for any part of the water piping system may be decided upon, is the rate of flow in the service pipe which in turn depends upon the number of hours for which the supply is available at sufficiently high pressure. If the number of hours for which the supply is available is less, there will be large number of fittings in use simultaneously and the rate of flow will be correspondingly large.

The data required for determining the size of the communication and service pipes are,

- a) the maximum rate of discharge required;
- b) the length of the pipe; and
- c) the head loss by friction in pipes, fittings and

meters.

4.7.3 Discharge Computation

4.7.3.1 Design of consumer's pipes based on fixture units

The design of the consumers' pipes or the supply pipe to the fixtures is based on,

- a) the number and kind of fixtures installed;
- b) the fixture unit flow rate; and
- c) the probable simultaneous use of these fixtures.

The rates at which water is desirably drawn into different types of fixtures are known. These rates become whole numbers of small size when they are expressed in fixture unit.

The water supply fixture units (WSFU) for different sanitary appliances or groups of appliances are given in Table 2.

4.7.3.2 Probable simultaneous demand

The possibility that all water supply taps in any system in domestic and commercial use will draw water at the same time is extremely remote. Designing the water mains for the gross flow will result in bigger and uneconomical pipe mains and may not be necessary. A probability study made by Hunter suggests the relationship shown in Fig. 2 and Table 3. In the absence of similar studies in India, the curves based on Hunter's study may be followed. In making use of these curves, special allowances are made as follows:

- a) Demands for service sinks are ignored in calculating the total fixture demand.
- b) Demands of supply outlets such as hose connections and air conditioners through which water flows more or less continuously over a considerable length of time shall be added to the probable flow rather than the fixture demand.
- c) Fixtures supplied with both hot and cold water exert reduced demands upon main hot water and cold water branches (not fixture branches).

4.7.3.3 The maximum flow rate and flush volumes shall be as given below:

<i>Plumbing Fixtures/Fittings</i>	<i>Maximum Flow Rate</i>
Water closets	6 litre/flush
Urinals	3.8 litre/flush
Lavatory, metered faucet (Public)	1 litre/use
Lavatory, faucet (Private)	8 litre/min
Sink, faucet	8 litre/min
Bidet, hand held spray	8 litre/min
Shower head	10 litre/min

NOTE — The maximum flow rates of plumbing fixtures and fittings provided are at the pressure of 0.42 N/mm². Water closet with dual flush cistern and urinals with reduced flush volumes are recommended. Further, users/designers are encouraged to use low flow fixtures.

4.7.4 Pipe Size Computation

Commercially available standard sizes of pipes are only to be used against the sizes arrived at by actual design. Therefore, several empirical formulae are used, even though they give less accurate results. The Hazen and William’s formula and the charts based on the same may be used without any risk of inaccuracy in view of the fact that the pipes normally to be used for water supply are of smaller sizes. Nomogram of Hazen and William’s equation has been provided in Annex C.

4.7.5 Adequate and Excessive Water Pressure

The requirements shall be as follows:

- a) *Adequate water pressure* — A minimum water pressure in accordance with 3.1.2 shall be ensured in the distribution system. The maximum pressure shall be maintained at

0.42 N/mm². Also, while designing, the maximum/minimum pressure required for operation of special fixtures and fittings is to be maintained as per the technical data sheet.

- b) *Excessive water pressure* — Whenever pressure exceeds 0.42 N/mm², and the distribution system may not be able to withstand the same, pressure reducing valves shall be installed for reduction of pressure.

4.7.6 Water Hammer Effects

Water hammer is recognized by the noise that is heard when valves are shut off. This occurs when flow of moving water is suddenly stopped due to closure of valve. Water hammer arrestors may be used to absorb high pressures resulting from sudden closure of valves.

Table 2 Water Supply Fixture Units (WSFU) for Different Fixtures with Minimum Pipe Sizes
(Clause 4.7.3.1)

Sl No.	Type of Fixture	Application		Minimum Pipe Size mm
		Private	Public	
(1)	(2)	(3)	(4)	(6)
i)	Bath tub	4	—	15
ii)	Ablution faucet/Bidet	1	1	15
iii)	Clothes washer	4	4 (see Note 7)	15
iv)	Dishwasher	1.5	1.5	15
v)	Drinking fountain	—	0.5 (0.75)	15
vi)	Hose bib	2.5	2.5	15
vii)	Wash basin (with metered faucet)	1	1	15
viii)	Wash basin (with standard faucet)	1.5	1.5 (2)	15
ix)	Service sink	1.5	3	15
x)	Kitchen sink	2	4	15
xi)	Surgical sink	—	2	15
xii)	Scrub station in hospital (per outlet)	—	3	15
xiii)	Shower	2	3	15
xiv)	Bathroom group (flush tank)	5	6	20
xv)	Bathroom group (flush valve)	8	10	25/32
xvi)	Urinal (flush valve)	3	5 (6)	20
xvii)	Urinal (flush tank)	2	2 (3)	15
xviii)	Urinal (sensor operated)	2	2 (3)	15
xix)	Water closet (flush valve)	6	8 (10)	25/32
xx)	Water closet (flush tank)	2	3 (5)	15
xxi)	Combination fixture (faucet)	3	—	15
xxii)	Laundry trays (faucet)	3	—	15

NOTES

- 1 The above table is based on Hunter’s method.
- 2 Hunter’s method of estimating load in plumbing systems is based on assigning a fixture unit (FU) weight to the plumbing fixtures and then converting these to equivalent litre per minute, based on the theory of probability of usage and based on the observation that all fixtures are not used simultaneously.
- 3 The fixture unit concept is a method of calculating maximum probable water demand within large buildings based on theory of probability. The method is based on assigning a fixture unit (FU) value to each type of fixture based on its rate of water consumption, on the length of time it is normally in use and on the average period between successive uses.
- 4 The values of probable demand will not change in respect of systems with flush valves and flush tanks for fixture units more than 1 000.
- 5 The fixtures or appliances which are not included in the above table may be sized referring to fixtures having similar flow rate and frequency of usage.
- 6 The minimum supply branch pipe sizes for individual fixtures are nominal sizes.
- 7 The clothes washer for public does not include large washer extractors, and in such cases the pipe sizing shall be determined as per manufacturer’s recommendations.
- 8 For more information on bathroom groups, reference may be made to specialist literature.
- 9 The fixture units listed in the above table represent the load for cold water service. The separate cold and hot water fixture unit value for fixtures having both hot and cold water connections may each be taken as three quarter of the listed total value of fixture.
- 10 A shower head over a bath tub does not increase the fixture unit value.
- 11 The values given in parentheses pertain to such public use buildings (congregation halls) where an enhanced requirement is expected to be encountered as compared to the normal maximum use in public use buildings.

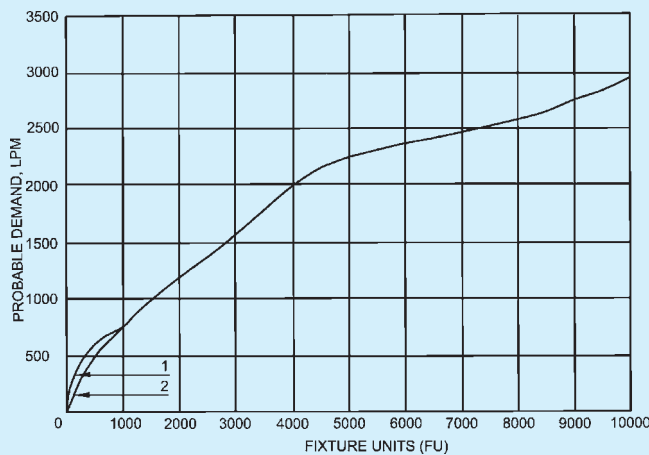

2A GRAPH FOR PROBABLE DEMAND UP TO 10 000 FU

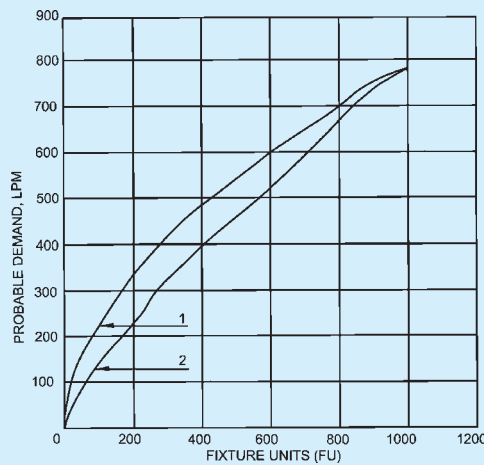

2B GRAPH FOR PROBABLE DEMAND UP TO 1 000 FU

Curve 1 — System With Flush Valves
 Curve 2 — System With Flush Tanks

FIG. 2 GRAPH FOR PROBABLE DEMAND

4.8 Distribution Systems in Multi-Storeyed Buildings

4.8.1 There are following four basic methods of distribution of water to a multi-storeyed buildings:

- Direct supply system from mains — public or private.
- Gravity distribution system.
- Pressurized distribution system (Hydro-pneumatic pumping system).
- Combined distribution system.

4.8.2 Direct Supply System from Mains — Public or Private

This system is adopted when adequate pressure is available in the mains to supply water at adequate pressure at the topmost floor. With limited pressure available in most city mains, water from direct supply is normally not available above two or three floors.

However, in gated communities or large campuses, this system can be adopted for taller buildings by incorporating design parameters such as elevated centralized water tank(s) or central hydro-pneumatic pumping system(s). For details of this system, reference may be made to good practice [9-1(6)] may be referred.

4.8.3 Gravity Distribution System

This is the most common water distribution system. The system comprises pumping water to one or more overhead water tanks. Water transferred to overhead tank(s) is distributed by gravity to various parts of the building by the system of piping network.

4.8.4 Pressurized Distribution System (Hydro-pneumatic Pumping System)

4.8.4.1 Pressurized distribution system is a direct pumping system incorporating a recharge diaphragm vessel.

Table 3 Probable Simultaneous Demand
(Clause 4.7.3.2)

SI No.	Demand in Fixture Units	Demand with Flush Tanks litre/min	Demand with Flush Valves litre/min
(1)	(2)	(3)	(4)
i)	1	0	—
ii)	2	3.8	—
iii)	3	11.4	—
iv)	4	15.1	—
v)	5	22.7	—
vi)	6	25.5	—
vii)	8	28.1	—
viii)	10	30.3	102.20
ix)	20	53.0	132.48
x)	30	75.7	155.19
xi)	40	94.6	177.90
xii)	50	109.8	196.82
xiii)	60	121.1	208.18
xiv)	70	132.5	223.32
xv)	80	143.8	234.67
xvi)	90	155.2	246.03
xvii)	100	166.5	257.38
xviii)	140	200.6	295.23
xix)	180	230.9	329.30
xx)	200	246.0	348.22
xxi)	250	283.9	382.29
xxii)	300	321.7	416.35
xxiii)	400	397.4	476.91
xxiv)	500	473.1	537.47
xxv)	750	643.5	673.73
xxvi)	1 000	787.3	787.28
xxvii)	1 250	908.4	908.40
xxviii)	1 500	1 010.6	1 010.60
xxix)	1 750	1 112.8	1 112.79
xxx)	2 000	1 215.0	1 214.99
xxxi)	2 500	1 419.4	1 419.38
xxxii)	3 000	1 635.1	1 635.12
xxxiii)	3 500	1 811.1	1 811.12
xxxiv)	4 000	1 987.1	1 987.13
xxxv)	4 500	2 115.8	2 115.82
xxxvi)	5 000	2 244.5	2 244.51
xxxvii)	5 500	2 312.6	2 312.64
xxxviii)	6 000	2 380.8	2 380.77
xxxix)	6 500	2 411.0	2 411.05
xl)	7 000	2 479.2	2 479.18
xli)	7 500	2 547.3	2 547.31
xlvi)	8 000	2 615.4	2 615.44
xliii)	8 500	2 683.6	2 683.57
xliv)	9 000	2 751.7	2 751.70
xlvi)	9 500	2 831.2	2 831.18
xlvi)	1 0000	2 910.7	2 910.67

4.8.4.2 The system may incorporate multiple pumps with suction and discharge manifolds and a control panel to facilitate automatic operation. Total discharge capacity required may be shared by a number of pumps, where the pumps operate in duty, assist and standby configuration.

4.8.4.3 The system shall also incorporate automatic sequencing of pumps to ensure even wear and tear also a low level cutoff, to prevent dry run of the pumps. The system shall be provided with continuous power supply with provision of emergency power backup.

4.8.4.4 Modern hydro-pneumatic systems are available with variable frequency drive, where the pump is efficiently used to deliver water at rates of flow as required by the system, by varying its speed with the assistance of an electronic device, thereby meeting the demand flow through variation in speed of the motor from 960 rpm to 3 000 rpm. With this arrangement, the same pump is able to deliver water at required pressure and flow as required at different times of the day. The system consumes energy in proportion to the work done and also helps in controlling the water surge in the distribution line.

4.8.4.5 Hydro-pneumatic system generally eliminates the need of an overhead tank. As a good engineering practice and to take care of emergencies, an overhead of smaller capacity should be provided which feeds by gravity to the system (see Fig. 3).

4.8.5 Combined Distribution System

4.8.5.1 In this system, a combination of gravity and pressurized distribution is adopted. A few upper floors are provided with a pressure booster pumping system to achieve the desired residual pressure, while the lower floors are fed by gravity supply.

4.8.5.2 Water collected in the overhead tank is distributed to the various parts of the building. To achieve required residual pressure for top 2 to 4 floors for proper functioning of the fixtures, a pressure booster pumping system is installed on the dedicated outlet from overhead tank with its own distribution piping serving the top 2 to 4 floors. For lower floors, water is distributed by gravity system.

4.8.5.3 Water distribution is accomplished by providing down take pipes in the shaft from the terrace ring mains (see Fig. 4).

4.8.6 Zoning of Distribution Systems

The zoning of water distribution network may be adopted for 7 to 9 floors, while conforming to the adequate pressure requirements and excessive pressure limitations in the hydraulic design (see 4.7.5). See Fig. 5 and Fig. 6 for zoning of gravity distribution system and pressurized distribution system (hydro-pneumatic pumping system), respectively.

The recommended maximum permissible velocity is 2.4 m/s for water distribution. In case of hot water distribution through copper pipes, the velocity is restricted to 1.5 m/s due to concern of erosion of the piping material.

4.9 General Requirements for Pipe Work

4.9.1 Mains

The following principles shall apply for the mains:

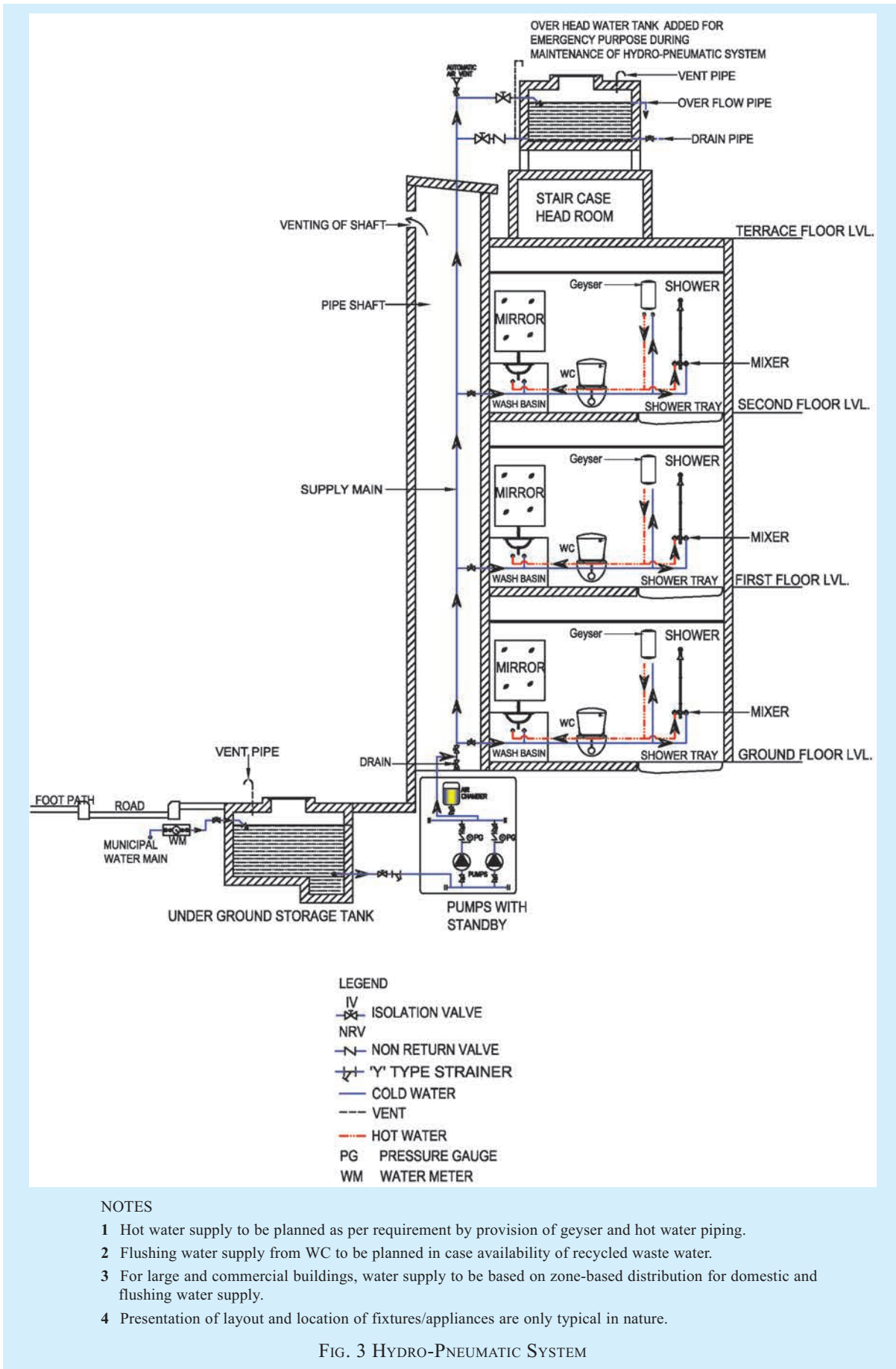

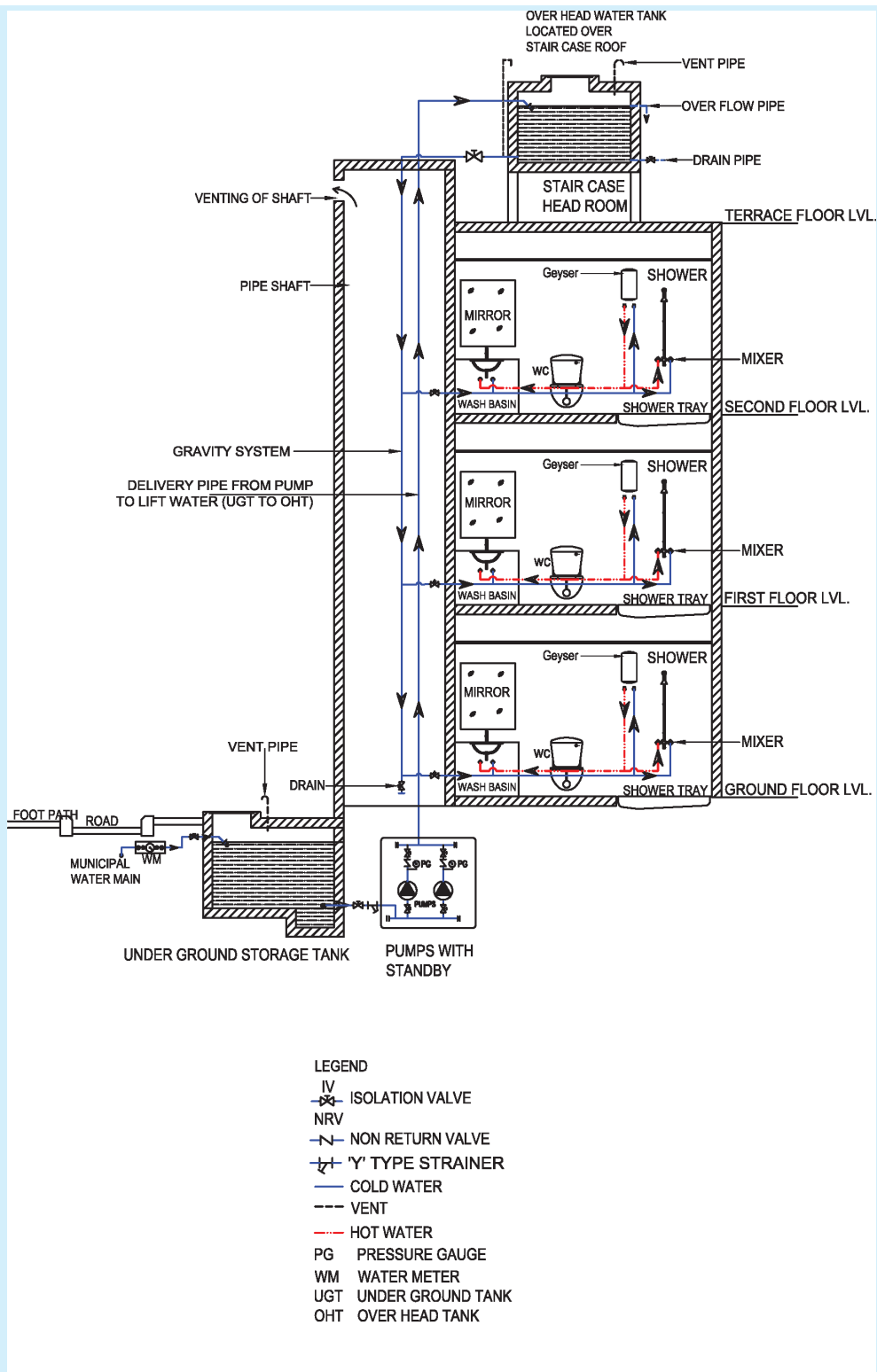

NOTES

- 1 Pump operation to be by level controller or air vessel/pressure switch at motorized valve at OHT.
- 2 Hot water supply to be planned as per requirement by provision of geyser and hot water piping.
- 3 Flushing water supply from WC to be planned in case of availability of recycled waste water.
- 4 For large and commercial buildings, water supply to be based on zone-based distribution for domestic and flushing water supply.
- 5 Presentation of layout and location of fixtures/appliances are only typical in nature.

FIG. 4 OVER HEAD TANK DISTRIBUTION

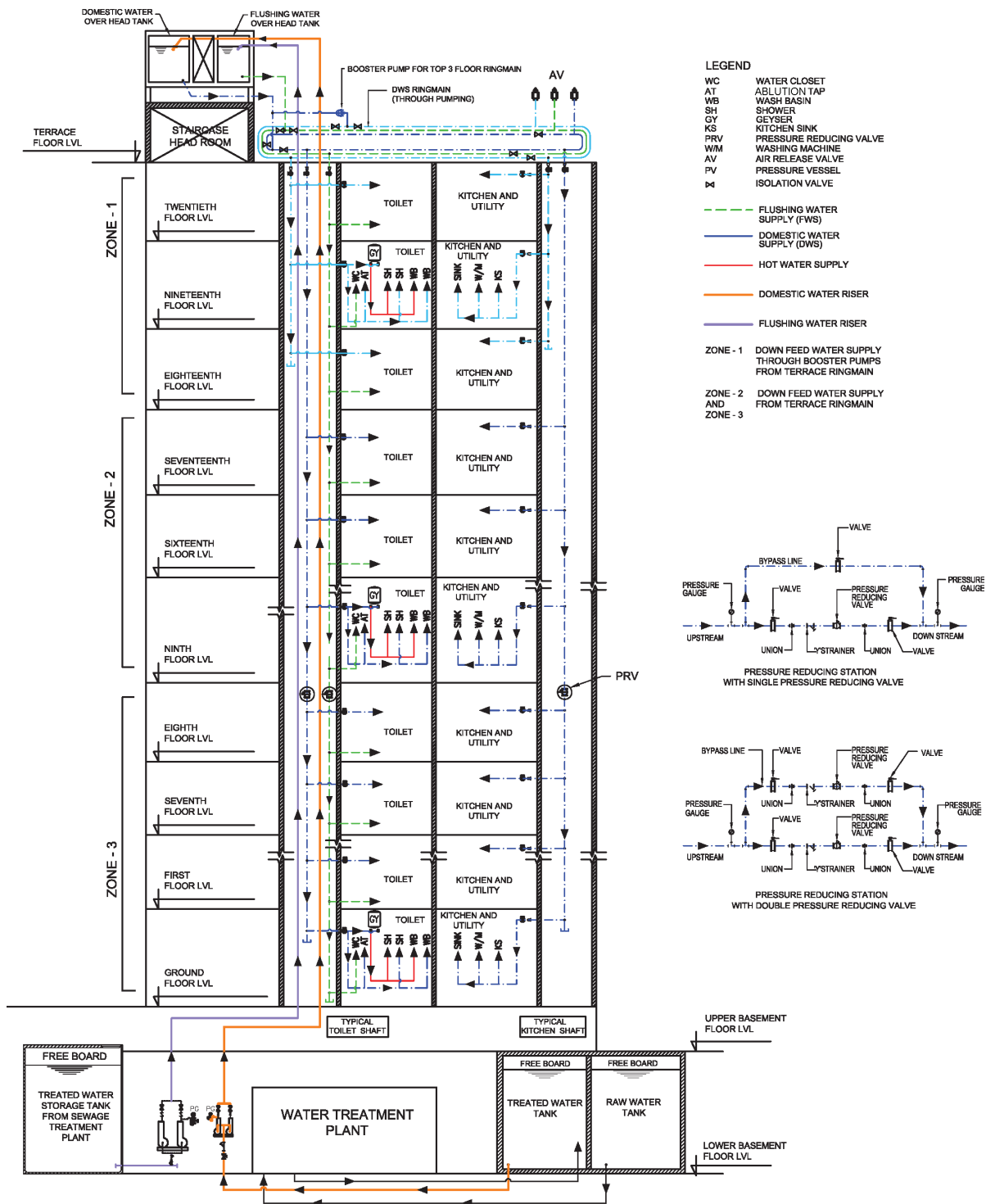

NOTES

- 1 Appurtenance, such as PRV should be planned in main piping network or branch piping, as required, to restrain pressure to upper limits.
- 2 Requirements for storage and usage of fire water shall be as per Part 4 'Fire and Life Safety' of the Code.

FIG. 5 SCHEMATIC DIAGRAM SHOWING THE DISTRIBUTION SYSTEM IN RESPECT OF GRAVITY SYSTEM FOR A MULTI-STOREYED BUILDING

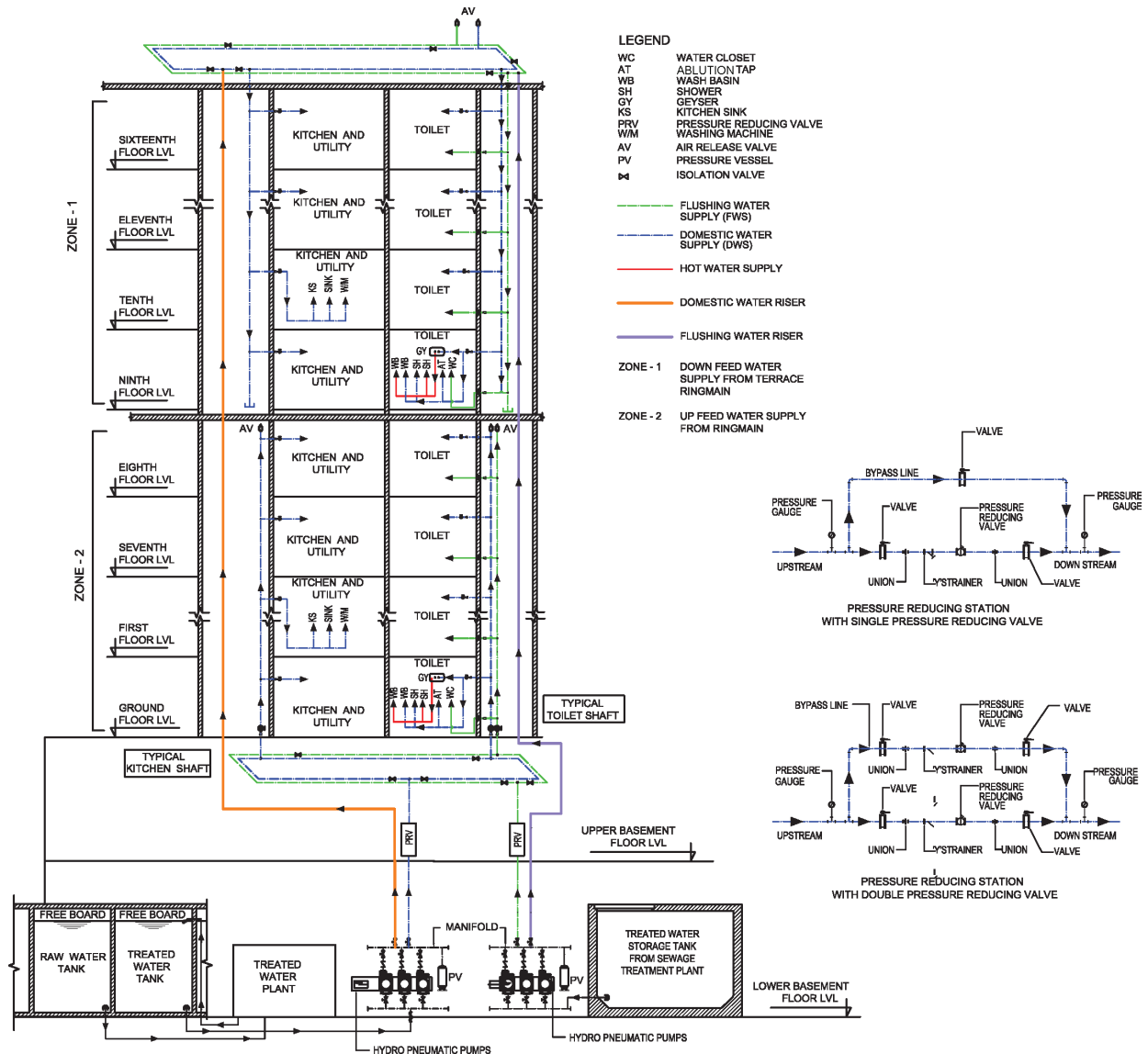

FIG. 6 SCHEMATIC DIAGRAM SHOWING THE DISTRIBUTION SYSTEM IN RESPECT OF HYDRO-PNEUMATIC SYSTEM FOR A MULTI-STOREYED BUILDING

- a) Service mains shall be of adequate size to give the required rate of flow.
- b) Mains shall be divided into sections by the provisions of sluice valves and other valves so that water may be shut off for repairs.
- c) To avoid dead ends, the mains shall be arranged in a grid formation or in a network.
- d) Where dead ends are unavoidable, a hydrant shall be provided to act as a wash-out.
- e) Wash-out valve shall not discharge directly into a drain or sewer, or into a manhole or chamber directly connected to it; an effectively trapped chamber shall be interposed, into which the wash-out shall discharge.
- f) Air valves shall be provided at all summits, and wash-out at low points between summits.
- g) Mains need not be laid at unvarying gradients,

but may follow the general contour of the ground. They shall, however, fall continuously towards the washout and rise towards the air valves. The gradient shall be such that there shall always be a positive pressure at every point under working conditions.

- h) Cover for the mains shall be at least 900 mm under roadways and 750 mm in the case of footpaths. This cover shall be measured from the top of the pipe to the surface of the ground.
- j) Mains shall be located sufficiently away from other service lines like electric and telegraph cables to ensure safety and where the mains cannot be located away from such lines, suitable protective measures shall be accorded to the mains. As far as possible, water supply and sewerage mains should be isolated from each other with certain minimum horizontal distance as per good engineering practice.

4.9.2 Communication Pipes

- a) Every premises that is supplied with water by the Authority shall have its own separate communication pipe. In the case of a group or block of premises belonging to the same owner the same communication pipe may supply water to more than one premises with the prior permission of the Authority.
- b) The communication pipe between the water main and the stop-cock at the boundary of the premises shall be laid by the Authority.
- c) Connections up to 50 mm diameter may be made on the water main by means of screwed ferrules, provided the size of the connections does not exceed one third the size of the water main. In all other cases, the connection shall be made by a T-branch off the water main.
- d) As far as practicable, the communication pipe and the underground service pipe shall be laid at right angles to the main and in approximately straight lines to facilitate location for repairs. It is also recommended that the communication pipe be laid in a pipe in pipe sleeve of larger diameter made of non-corrosive material to protect the communication pipe.
- e) Every communication pipe shall have a stop-cock and meter inserted in it. The waterway of each such fitting shall not be less than the internal sectional area of the communication pipe and the fittings shall be located within the premises at a conspicuous place accessible to the Authority which shall have exclusive control over it.

4.9.3 Consumer Pipes

- a) No consumer pipe shall be laid in the premises

to connect the communication pipe without the approval of the Authority.

- b) The consumer pipe within the premises shall be laid underground with a suitable cover to safeguard against damage from traffic and extremes of weather.
- c) To control the branch pipe to each separately occupied part of a building supplied by a common service pipe, a stop valve shall be fixed to minimize the interruption of the supply during repairs. All such stop valves shall be fixed in accessible positions and properly protected. To supply water for drinking or for culinary purposes, direct taps shall be provided on the branch pipes connected directly to the consumer pipe. In the case of multi-storeyed buildings, down take taps shall be supplied from overhead tanks.
- d) Pumps shall not be allowed on the service pipe, as they cause a drop in pressure on the suction side, thereby affecting the supply to the adjoining properties. In cases where pumping is required, a properly protected storage tank of adequate capacity shall be provided to feed the pump.
- e) No direct boosting (by booster pumps) shall be allowed from the service pipes (communication and consumer pipes).
- f) Consumer pipes shall be so designed and constructed as to avoid air-locks. Draining taps shall be provided at the lowest points from which the piping shall rise continuously to draw-off taps.
- g) Consumer pipes shall be so designed as to reduce the production and transmission of noise as much as possible.
- h) Consumer pipes in roof spaces and unventilated air spaces under floors or in basements shall be protected against corrosion.
- j) Consumer pipes shall be so located that they are not unduly exposed to accidental damage and shall be fixed in such positions as to facilitate cleaning and avoid accumulations of dirt.
- k) All consumer pipes shall be so laid as to permit expansion and contraction or other movements.

4.9.4 Prohibited Connections

- a) A service pipe shall not be connected into any distribution pipe; such connection may permit the backflow of water from a cistern into the service pipe, in certain circumstances, with

consequent danger of contamination and depletion of storage capacity. It might also result in pipes and fittings being subjected to a pressure higher than that for which they are designed, and in flooding from overflowing cisterns.

- b) No pipe for conveyance or in connection with water supplied by the Authority shall communicate with any other receptacle used or capable of being used for conveyance other than water supplied by the Authority.
- c) Where storage tanks are provided, no person shall connect or be permitted to connect any service pipe with any distributing pipe.
- d) No service or supply pipe shall be connected directly to any water-closet or a urinal. All such supplies shall be from flushing cisterns/ flush valves which shall be supplied from storage tank.
- e) No service or supply pipe shall be connected directly to any hot water system or to any other apparatus used for heating other than through a feed cistern thereof.

4.10 Jointing of Pipes

4.10.1 Cast Iron Pipes

Jointing may be done by any of the following methods:

- a) Spigot and socket joints, or
- b) Flanged joints.

in accordance with good practice [9-1(7)]. The lead shall conform to the accepted standards [9-1(8)]. Alternative jointing materials which are found to be equally effective, may be used in place of lead joints, with the approval of the Authority.

4.10.2 Steel Pipes

Plain-ended steel pipes may be jointed by welding. Electrically welded steel pipes shall be jointed in accordance with good practice [9-1(9)].

4.10.3 Wrought Iron and Steel Screwed Pipes

Screwed wrought iron or steel piping may be jointed with screwed and socketed joints. Care shall be taken to remove any burr from the end of the pipes after screwing. A jointing compound approved by the Authority and containing no red lead composition shall be used. Screwed wrought iron or steel piping may also be jointed with screwed flanges.

4.10.4 Asbestos Cement Pipes

Asbestos cement pipes may be jointed in accordance with good practice [9-1(10)].

4.10.5 Copper Pipes

Copper pipes shall be jointed by internal solder ring joint, end-brazing joint or by use of compression fitting. The flux used shall be non-toxic and the solder used shall be lead free. The use of dezincification fittings shall be made in case of jointing of copper pipe and steel pipe. The jointing technology shall be used as per good engineering practice and as per manufacturers recommendations.

4.10.6 Concrete Pipes

Concrete pipes shall be jointed in accordance with good practice [9-1(11)].

4.10.7 Polyethylene and Unplasticized PVC Pipes

Polyethylene and unplasticized PVC pipes shall be jointed in accordance with good practice [9-1(12)].

4.11 Backflow Prevention

4.11.1 The installation shall be such that water delivered is not liable to become contaminated or that contamination of the public water supply does not occur.

4.11.2 The various types of piping and mechanical devices acceptable for backflow protection are:

- a) Barometric loop,
- b) Air gap,
- c) Atmosphere vacuum breaker,
- d) Pressure vacuum breaker,
- e) Double check valve, and
- f) Reduced pressure backflow device.

4.11.3 The installation shall not adversely affect drinking water,

- a) by materials in contact with the water being unsuitable for the purpose;
- b) as a result of backflow of water from water fittings, or water using appliances into pipework connected to mains or to other fittings and appliances;
- c) by cross-connection between pipes conveying water supplied by the water undertaker with pipes conveying water from some other source; and
- d) by stagnation, particularly at high temperatures.

4.11.4 No pump or similar apparatus, the purpose of which is to increase the pressure in or rate of flow from a supply pipe or any fitting or appliance connected to a supply pipe, shall be connected unless the prior written permission of the water supplier has been obtained in each instance.

The use of such a pump or similar apparatus is likely to lead to pressure reduction in the upstream pipe work which, if significant, increase the risk of backflow from other fittings.

4.11.5 The water shall not come in contact with unsuitable materials of construction.

4.11.6 No pipe or fitting shall be laid in, on or through land fill, refuse, an ash pit, sewer, drain, cesspool or refuse chute or any manhole connected with them.

4.11.7 No pipe susceptible to deterioration by contact with any substance shall be laid or installed in a place where such deterioration is likely to occur. No pipe that is permeable to any contaminant shall be laid or installed in any position where permeation is likely to occur.

4.11.8 If a liquid (other than water) is used in any type of heating primary circuit, which transfers heat to water for domestic use, the liquid shall be non-toxic and non-corrosive.

4.11.9 A backflow prevention device shall be arranged or connected at or as near as practicable to each point of delivery and use of water. Appliances with built-in backflow prevention shall be capable of passing the test. All backflow prevention devices shall be installed so that they are accessible for examination, repair or replacement. Such devices shall be capable of being tested periodically by the Authority to ensure that the device is functioning efficiently and no backflow is occurring at any time.

4.12 Conveyance and Distribution of Water Within the Premises

4.12.1 Basic Principles

Wholesome water supply provided for drinking and culinary purposes shall not be liable to contamination from any less satisfactory water. There shall, therefore, be no cross-connection whatsoever between the distribution system for wholesome water and any pipe or fitting containing unwholesome water, or water liable to contamination, or of uncertain quality, or water which has been used for any other purpose. The provision of reflux or non-return valves or closed and sealed stop valves shall not be construed as a permissible substitute for complete absence of cross-connection.

4.12.2 The design of the pipe work shall be such that there is no possibility of backflow towards the source of supply from any cistern or appliance, whether by siphonage or otherwise. Reflux non-return valves shall not be relied upon to prevent such backflow.

4.12.3 Where a supply of less satisfactory water than

wholesome water becomes inevitable as an alternative or is required to be mixed with the latter, it shall be delivered only into a cistern and by a pipe or fitting discharging into the air gap at a height above the top edge of the cistern equal to twice its nominal bore and in no case less than 150 mm. It is necessary to maintain a definite air gap in all appliances or taps used in water-closets.

4.12.4 All pipe work shall be so designed, laid or fixed and maintained as to remain completely water-tight, thereby avoiding wastage, damage to property and the risk of contamination.

4.12.5 No water supply line shall be laid or fixed so as to pass into or through any sewer, scour outlet or drain or any manhole connected therewith, nor through any ash pit or manure pit or any material of such nature that is likely to cause undue deterioration of the pipe.

4.12.5.1 Where the laying of any pipe through corrosive soil or pervious material is unavoidable, the piping shall be properly protected from contact with such soil or material by being carried through an exterior pipe sleeves as approved by the Authority. Any existing piping or fitting laid or fixed, which does not comply with the above requirements, shall be removed immediately by the consumer and re-laid by him in conformity with the above requirements and to the satisfaction of the Authority.

4.12.5.2 Where lines have to be laid in close proximity to electric cables or in corrosive soils, adequate precautions/protection should be taken to avoid corrosion.

4.12.6 Underground piping shall be laid at such a depth that it is unlikely to be damaged by frost or traffic loads and vibrations. It shall not be laid in ground liable to subsidence, but where such ground cannot be avoided, special precautions shall be taken to avoid damage to the piping. Where piping has to be laid across recently disturbed ground, the ground shall be thoroughly consolidated so as to provide a continuous and even support. In the case of frost conditions, the pipes shall be laid below the frost line with suitable insulation to the pipes.

4.12.7 In designing and planning the layout of the pipe work, due attention shall be given to the maximum rate of discharge required, economy in labour and materials, protection against damage and corrosion, water hammer, protection from frost, if required, and avoidance of airlocks, noise transmission and unsightly arrangement.

4.12.8 To reduce frictional losses, piping shall be as

smooth as possible inside. Methods of jointing shall be such as to avoid internal roughness and projection at the joints, whether of the jointing materials or otherwise.

4.12.9 Change in diameter and in direction shall preferably be gradual rather than abrupt to avoid undue loss of head. No bend or curve in piping shall be made which is likely to materially diminish or alter the cross-section.

4.12.10 No boiler for generating steam or closed boilers of any description or any machinery shall be supplied direct from a service or supply pipe. Every such boiler or machinery shall be supplied from a feed cistern.

4.13 Laying of Mains and Pipes on Site

4.13.1 The mains and pipes on site shall be laid in accordance with good practice [9-1(13)]. The pipes laid in buildings situated in seismic zone and across large building expansion joints should be installed with suitable expansion bellows and expansion loops to mitigate expansion of piping system for its intended function without failures.

4.13.2 *Excavation and Refilling*

The bottoms of the trench excavations shall be so prepared that the barrels of the pipes, when laid, are well bedded for their whole length on a firm surface and are true to line and gradient. In the refilling of trenches, the pipes shall be surrounded with fine selected material, well rammed so as to resist subsequent movement of the pipes. No stones shall be in contact with the pipes; when resting on rock, the pipes shall be bedded on fine-selected material or (especially where there is a steep gradient) on a layer of concrete.

4.13.2.1 The pipes shall be carefully cleared of all foreign matter before being laid.

4.13.3 *Laying Underground Mains*

Where there is a gradient, pipe laying shall proceed in 'uphill' direction to facilitate joint making.

4.13.3.1 Anchor blocks shall be provided to withstand the hydraulic thrust.

4.13.4 Iron surface boxes shall be provided to give access to valves and hydrants and shall be supported on concrete or brickwork which shall not be allowed to rest on pipes.

4.13.5 *Laying Service Pipes*

4.13.5.1 Service pipes shall be connected to the mains by means of right-hand screw down ferrule or T-branches. The ferrules shall conform to accepted standards [9-1(14)].

4.13.5.2 Precaution against contamination of the mains shall be taken when making a connection and, where risk exists, the main shall be subsequently disinfected. The underground water service pipe and the building sewer or drain shall be kept at a sufficient distance apart so as to prevent contamination of water. Water service pipes or any underground water pipes shall not be run or laid in the same trench as the drainage pipe. Where this is unavoidable, the following conditions shall be fulfilled:

- a) The bottom of the water service pipe, at all points, shall be at least 300 mm above the top of the sewer line at its highest point.
- b) The water service pipe shall be placed on a solid shelf excavated on one side of the common trench.
- c) The number of joints in the service pipe shall be kept to a minimum.
- d) The materials and joints of sewer and water service pipe shall be installed in such a manner and shall possess such necessary strength and durability as to prevent the escape of solids, liquids and gases there from under all known adverse conditions, such as corrosion strains due to temperature changes, settlement, vibrations and superimposed loads.

4.13.5.3 The service pipe shall pass into or beneath the buildings at a depth of not less than 750 mm below the outside ground level and, at its point of entry through the structure, it shall be accommodated in a sleeve which shall have previously been solidly built into the wall of the structure. The space between the pipe and the sleeve shall be filled with bituminous or other suitable material for a minimum length of 150 mm at both ends.

4.13.6 *Pipes Laid through Ducts, Chases, Notches or Holes*

Ducts or chases in walls for piping shall be provided during the building of the walls. If they are cut into existing walls, they shall be finished sufficiently smooth and large enough for fixing the piping.

4.13.6.1 Piping laid in notches or holes shall not be subjected to external pressure.

4.13.7 *Lagging of Pipes*

Where lagged piping outside buildings is attached to walls, it shall be entirely covered all round with waterproof and fire insulating material and shall not be in direct contact with the wall. Where it passes through a wall, the lagging shall be continued throughout the thickness of the wall.

4.14 Hot Water Supply Installations

4.14.1 Design Consideration

4.14.1.1 General

In electric water heating practice for domestic purposes, the accepted method is to use storage heaters in which water is steadily heated up to a predetermined temperature and stored until required for use. The heating by electricity of a large quantity of water, such as water required for a hot bath, within the time normally taken to run the water into the bath, requires a heater of too high a rating to be practicable in normal domestic premises. It should be ensured that such vents and pipes are above reach/inaccessible during daily use to avoid accidents such as accidental contact and burning.

4.14.1.2 In modern hotels and apartment blocks and service apartments, centralized storage and distribution systems are adopted, where other energy sources such as oil, gas, solar panels, etc, may be used for the generation of hot water as these options prove more economical and convenient in heating large volumes of water for storage.

4.14.1.3 When water supplied to the buildings contain dissolved salts resulting in hardness of water, measures such as installation of water softening plants, etc, shall be taken to avoid formation of scales in the hot water installations.

4.14.2 Storage Temperature

4.14.2.1 The design of hot water supply system and its appliances shall be based on the temperatures at which water is normally required for the various uses, namely:

- Scalding : 65°C
- Sink : 60°C
- Hot bath : 43°C as run for use at 41°C
- Warm bath : 37°C
- Tepid bath : 29.5°C

4.14.2.2 In order to minimize the danger of scalding, precipitation of scale from hard water, standing heat losses, risk of steam formation and the possibility of damage to porcelain or other fittings and to surface finishes, a storage temperature of 60°C is recommended. If storage capacity is limited, a higher temperature up to 65°C may be adopted when soft water is used.

4.14.3 Storage Capacity

The size of the storage vessel is governed by the maximum short time demand of the domestic premises. Depending on local conditions this shall be 50 litre to 75 litre at 60°C in a dwelling with a bath tub and 25 litre at 60°C for a shower or a tap (for bucket supply). The capacity of the storage vessel shall not be less than 20 percent in excess of the required maximum short time

demand. In larger houses where a single hot water heater is intended to supply hot water to more than one bathroom or kitchen or both, the maximum short time demand shall be estimated and the capacity decided accordingly. Small electric or gas storage heaters of 15 litre to 25 litre capacity may be used to supply one or two points of draw off depending on the use of hot water.

4.14.4 Rate of Flow

With storage type installation, the recommended maximum rates of flow for different types of fixtures are given in Table 4.

Table 4 Rate of Hot Water Flow
(Clause 4.14.4)

Sl No.	Fixtures	Rate of Flow litre/min
(1)	(2)	(3)
i)	Kitchen sink	5
ii)	Wash basin	5
iii)	Shower (spray type)	6.5

4.14.4.1 Hot water supply systems

Identification of water supply system is critical for safe functioning and protection of occupants. The first step is correct labelling of various water systems in the building. The requirements of identification/labelling shall be adhered on every installation where different water systems are provided.

While designing centralized hot water systems in major projects, the following points should be considered:

- a) Fuel to be used,
- b) Location and dimension of boiler house and calorifier chambers,
- c) Location and dimension of fuel storage tank,
- d) Means of ash disposal (in case of solid fuel),
- e) Location and dimension of chimney,
- f) Location of cold water points,
- g) Drainage facilities during emptying,
- h) Quality of water supply, and
- j) Provision for air combustion and ventilation.

In laying hot water piping systems, the pressures of hot and cold water should be made equal at each fixture, especially where mixing faucets/thermostatic mixer are to be used. Otherwise, there would be imbalance of pressure where one pressure would be more than the other. These conditions should be avoided by proper design of the system.

Return circulation systems are recommended for energy conservation and user comfort.

In the inverted systems, hot water heaters and tanks

are located at the highest point of water supply system and supply and return risers below the level of hot water source.

Environmental and consumer requirements should be considered when planning the installation of a solar hot water system. Factors affecting the performance of a system and decisions about how the system should be installed, include,

- 1) the climate zone of the site and possibility of,
 - i) shading;
 - ii) frost and freezing;
 - iii) wind;
 - iv) dust;
 - v) hail; and
 - vi) corrosion and scaling.
- 2) the ambient air temperature.
- 3) the cold water temperature.
- 4) the availability of space and pitch of a suitable south-facing roof.
- 5) the presence and location of an existing hot water service.
- 6) the available energy sources (for example, gas or electricity).
- 7) the householder’s hot water usage.
- 8) the householder’s budget.

4.14.5 Design of Storage Vessel

Storage tanks shall be oblong or cylindrical in shape and shall be installed, preferably with the long side vertical in order to assist the effective stratification or ‘layering’ of hot or cold water. The ratio of height to width or diameter shall not be less than 2 : 1. An inlet baffle should preferably be fitted near the cold inflow pipe in order to spread the incoming cold water.

4.14.6 Materials for Storage Vessel and Pipes

4.14.6.1 Under no circumstances shall ungalvanized (black) mild steel pipes and fittings, such as sockets, bushes, etc, be used in any part of domestic hot water installation, including the cold feed pipe and the vent pipe. Materials resistant to the chemical action of water supplied shall be used in construction of vessels and pipes. Each installation shall be restricted to one type of metal only, such as all copper or all galvanized mild steel. When water supplied is known to have appreciable salt content, galvanized iron vessels and pipes shall not be used. However, it is advisable to avoid use of lead pipes in making connection to wash basins. Where required it is also advisable to use vessels lined internally with glass, stainless steel, etc.

4.14.6.2 In general, tinned copper and other metals such as monel metal, etc, are suitable for most types of water. The suitability of galvanized mild steel for storage tanks

depends upon the pH value of the water and the extent of its temporary hardness. For values of pH 7.2 or less, galvanized mild steel should not be used. For values of pH 7.3 and above, galvanized mild steel may be used provided the corresponding temporary hardness is not lower than those given below:

<i>pH Value</i>	<i>Minimum Temporary Hardness Required mg/l</i>
7.3	210
7.4	150
7.5	140
7.6	110
7.7	90
7.8	80
7.9-8.5	70

4.14.7 Location of Storage Vessel

The loss of heat increases in proportion to the length of pipe between the storage vessel and the hot water outlet since each time the water is drawn, the pipe fills with hot water which then cools. The storage vessel shall therefore be so placed that the pipe runs to the most frequently used outlets are as short as possible.

4.14.8 Immersion Heater Installation

4.14.8.1 If a domestic storage vessel is to be adopted to electric heating by the provision of an immersion heater and thermostat, the following precautions shall be observed:

- a) *Location of immersion heaters* — The immersion heater shall be mounted with its axis horizontal, except in the case of the circulation type which is normally mounted with its axis approximately vertical.
- b) In a tank with a flat bottom, a space of not less than 75 mm below the immersion heater and 50 mm below the cold feed connection shall be provided to allow for accumulation of sludge and scale, where it will not affect the working of the immersion heater.
- c) In a cylindrical storage vessel with inwardly dished bottom, the inlet pipe shall be so arranged that the incoming cold water is not deflected directly into the hot water zone. The lowest point of the immersion heater shall be 25 mm above the centre line of the cold feed inlet, which, in turn, is usually 100 mm above the cylinder rim.
- d) *Location of thermostat* — Where the thermostat does not form an integral part of the immersion heater, it shall be mounted with its axis horizontal, at least 50 mm away from

and not lower than the immersion heater.

- e) *Dual heater installations* — If desired, the principle of the dual heater may be adopted. In this case, one heater and its thermostat shall be installed at a low level as indicated in (b) and (c). The second heater and its thermostat shall be similarly disposed in the upper half of the cylinder at a level depending on the reserve of hot water desired for ordinary domestic use. The bottom heater shall be under separate switch control.
- f) *Clearance around storage vessel* — Adequate clearance shall be provided between the tank and the cupboard, door or walls to allow convenient insertion and adjustment of the immersion heater and thermostat and to give space for thermal insulation.

4.14.8.2 Rating of immersion heaters

The rating of an immersion heater shall be determined according to the following factors:

- a) Proposed hot water storage capacity (the maximum with cold water as indicated in 4.14.3 shall be taken into account),
- b) Rate of utilization (draw off frequency),
- c) Permissible recovery period, and
- d) Inlet water temperature.

For details regarding rated input of water, refer to good practice [9-1(15)].

4.14.9 Thermal Insulation

The hot water storage vessel and pipes shall be adequately insulated, wherever necessary to minimize heat loss. The whole external surface of the storage vessel including the cover to the man hole shall also be duly insulated.

Insulation may be provided by wrapping storage vessel and pipes with fibre glass, mineral wool or closed cell flexible elastomeric foam based materials of desired thickness, covered with cladding for protection from damage or from weather in case of external use.

4.14.10 Cold Water Supply to Heaters

4.14.10.1 A storage water heater (pressure type) shall be fed from a cold water storage tank and under no circumstances connected directly to the water main, except the type which incorporates a feed tank with ball valves and overflow pipe arrangement (cistern type heaters) or non-pressure type heaters.

4.14.10.2 Storage cisterns

4.14.10.2.1 The storage capacity of a cold water tank shall be at least twice the capacity of the hot water heater. The capacity of the storage tank may, however, be 1.5

times when the number of heaters connected to one common tank exceeds 10.

4.14.10.2.2 The storage tank for supply of cold water to hot water heaters shall be separate, if practicable. In the case of a common tank which also supplies cold water to the fixtures, this cold water supply connection shall be so arranged that 50 percent of the net capacity, worked out as in 4.14.10.2.1, shall be available for supply to the hot water heaters.

4.14.10.2.3 In the case of multi-storeyed buildings where a common overhead tank over the stair/lift well is generally installed, it is advisable to have one or more local tanks for supply to the hot water heaters or a compartment in the tank with required storage always available for hot water heater.

4.14.10.2.4 In tall multi-storeyed buildings where the static pressure increases with the height, the total static pressure on the hot water heaters on the lowest floor shall not exceed the rated working pressure of the hot water heater installed. Should the height of the building so require, additional tanks shall be provided on the intermediate floors to restrict the static head to permissible limits or the pressure shall be reduced to working pressure by providing pressure reducing valves.

4.14.10.2.5 As an alternative to the arrangements stated in 4.14.10.2.3 and 4.14.10.2.4, an individual storage tank in each flat may be provided for supply to hot water heaters.

4.14.11 Cold Water Feed

4.14.11.1 The feed pipe connecting cold water tank with the hot water heater shall not be of less than 20 mm bore and it shall leave the cold water tank at a point not less than 50 mm above the bottom of the tank and shall connect into the hot water heater near its bottom. The feed pipe shall not deliver cold water to any other connection, but into the hot water cylinders only.

4.14.11.2 In the case of multi-storeyed buildings, a common cold water feed pipe may be installed, but each hot water heater shall be provided with a check valve (horizontal type check valve shall be preferred to vertical type for easy maintenance).

4.14.11.3 Care shall be taken in installing the piping to prevent air locks in the piping and negative pressure in the hot water heater. Cold water feed pipe shall not be cross-connected with any other source of supply under pressure.

4.14.12 Hot Water Piping

4.14.12.1 Expansion pipe or vent pipe

4.14.12.1.1 Each non-pressure type hot water heater or cylinder shall be provided with a vent pipe of not

less than 20 mm bore. The vent pipe shall rise above the water line of the cold water tank by at least 150 mm plus 10 mm for every 300 mm height of the water line above the bottom of the heater. The vent shall discharge at a level higher than the cold water tank and preferably in the cold water tank supplying the hot water heaters. Care shall be taken to ensure that any accidental discharge from the vent does not hurt or scald any passerby or persons in the vicinity.

It shall be ensured that such vents and pipes are so located so as not to encroach into the minimum maneuvering space and should be suitably insulated to avoid accidental contact and burns.

NOTE — Pressure type water heaters are very commonly used and non-pressure type is slowly phased out.

4.14.12.1.2 The vent pipe shall be connected to the highest point of the heater vessel and it shall not project downwards inside it, as otherwise air may be trapped inside, resulting in surging and consequent noises.

4.14.12.1.3 At no point, after leaving the vessel, shall the vent pipe dip below the level of its connection with the vessel.

4.14.12.1.4 A vent pipe may, however, be used for supply of hot water to any point between the cold water tank and the hot water heaters.

4.14.12.1.5 The vent pipe shall not be provided with any valve or check valves.

4.14.12.2 Hot water heaters

4.14.12.2.1 The common hot water delivery pipe shall leave the hot water heater near its top and shall be of not less than 20 mm bore generally, not less than 25 mm bore if hot water taps are installed on the same floor as that on which the hot water heater is situated.

4.14.12.2.2 Hot water taps shall be of such design as would cause the minimum friction. Alternatively, oversized tap may be provided, such as a 20 mm tap on a 15 mm pipe.

4.14.12.2.3 The hot water distributing system shall be so designed as to ensure that the time lag between opening of the draw-off taps and discharge of hot water is reduced to the minimum to avoid wastage of an undue amount of water which may have cooled while standing in the pipes when the taps are closed. With this end in view, a secondary circulation system with flow and return pipes from the hot water tank shall be used where justified. Whether such a system is used or not, the length of pipe to a hot water draw-off tap, measured along the pipe from the tap to the hot water tank or the secondary circulation pipe, shall not exceed the lengths given in Table 5.

Table 5 Maximum Permissible Lengths of Hot Water Draw-Off Pipes
(Clause 4.14.12.2.3)

Sl No.	Largest Internal Diameter of Pipe	Length m
(1)	(2)	(3)
i)	Not exceeding 20 mm	12
ii)	Exceeding 20 mm but not exceeding 25 mm	7.5
iii)	Exceeding 25 mm	3.0

NOTE — In the case of a composite pipe of different diameters, the largest diameter is to be taken into consideration for the purpose of this table.

4.14.12.2.4 Wherever mixing of hot and cold water is done by a mixing fitting, that is, hot and cold stop-cocks deliver to a common outlet of mixed water (that is, showers, basin or bath supply fittings), the pressure in the cold and hot water systems shall be equal. This can be achieved by connecting the cold water supply from an overhead tank at the same static height as the overhead tank supplying cold water to the hot water heaters. In case this is not possible, hot and cold water should be supplied to the fixtures by separate supply taps.

The hot and cold water thermostatic mixers/diverters/faucets for public use should have ‘hot’ and ‘cold’ clearly marked in the form of colour coding and tactile information. The functioning of hot and cold water from the thermostatic mixer/diverter/faucet should be consistent, for example, a clockwise turn should result in discharge of hot water and counter clockwise for cold. It is recommended that a thermostat be installed to limit the temperature of the hot water to a maximum of 40°C in order to prevent scalding. All faucets/mixers/diverts in public use shall be automatic (sensor operated) or lever type (see also B-7 and B-9 of Part 3 ‘Development Control Rules and General Building Requirements’ of the Code).

4.14.13 Types of Hot Water Heaters

The various types of water heaters used for preparation of hot water are as follows:

- a) *Electric storage heaters:*
 - 1) Non-pressure or open outlet type,
 - 2) Pressure type,
 - 3) Cistern type, and
 - 4) Dual heater type.
- b) *Gas water heaters:*
 - 1) Instantaneous type, and
 - 2) Storage type.
- c) *Solar heating systems:*
 - 1) Independent roof mounted heating units, and

- 2) Centrally banked heated system.
- d) *Central hot water system:*

- 1) Oil fired,
- 2) Gas fired,
- 3) Electrical coil type, and
- 4) Heat Pump.

4.14.13.1 The quality and construction of the different types of hot water heaters shall be in accordance with good practice [9-1(16)].

4.14.13.2 Requirements in regard to inspection and maintenance of hot water supply installations shall be in accordance with **4.15.1** to **4.15.4**.

4.15 Inspection and Testing

4.15.1 Testing of Mains before Commencing Work

All pipes, fittings and appliances shall be inspected, before delivery at the site to see whether they conform to accepted standards. All pipes and fittings shall be inspected and tested by the manufacturers at their factory and shall comply with the requirements of this Section. They shall be tested hydraulically under a pressure equal to twice this maximum permissible working pressure or under such greater pressure as may be specified. The pipes and fittings shall be inspected on site before laying and shall be sounded to disclose cracks. Any defective items shall be clearly marked as rejected and forthwith removed from the site.

4.15.2 Testing of Mains after Laying

After laying and jointing, the main shall be slowly and carefully charged with water by providing a 25 mm inlet with a stop-cock, so that all air is expelled from the main. The main is then allowed to stand full of water for a few days if time permits, and then tested under pressure. The test pressure shall be 0.5 N/mm² or double the maximum working pressure, whichever is greater. The pressure shall be applied by means of a manually operated test pump, or, in the case of long mains or mains of a large diameter, by a power-driven test pump, provided the pump is not left unattended. In either case, due precaution shall be taken to ensure that the required test pressure is not exceeded. Pressure gauges shall be accurate and shall preferably have been recalibrated before the test. The pump having been stopped, the test pressure shall maintain itself without measurable loss for at least 5 min. The mains shall be tested in sections as the work of laying proceeds; it is an advantage to have the joints exposed for inspection during the testing. The open end of the main may be temporarily closed for testing under moderate pressure by fitting a water-tight expanding plug of which several types are available. The end of the main and the plug shall be secured by struts or otherwise, to resist the

end thrust of the water pressure in the mains.

4.15.2.1 If the section of the main tested terminates into a sluice valve, the wedge of the valve shall not be used to retain the water; instead the valve shall be temporarily fitted with a blank flange, or, in the case of a socketed valve, with a plug, and the wedge placed in the open position while testing. End support shall be given as in **4.15.2**.

4.15.3 Testing of Service Pipes and Fittings

When the service pipe is complete, it shall be slowly and carefully charged with water, allowing all air to escape, care being taken to avoid all shock or water hammer. The service pipe shall then be inspected under working conditions of pressure and flow. When all draw-offs taps are closed, the service pipe shall be absolutely water-tight. All piping, fittings and appliances shall be checked for satisfactory support, and protection from damage, corrosion and frost. Because of the possibility of damage in transit, cisterns shall be re-tested for water-tightness on arrival at the site, before fixing.

4.15.4 In addition to the provisions given in **4.15.1**, provisions given in **4.15.4.1** to **4.15.4.3** shall also apply to hot water supply installations in regard to inspection and testing.

4.15.4.1 Testing of the system after installation

After the hot water system, including the hot water heaters, has been installed, it shall be carefully charged with water, so that all air is expelled from the system. The entire system shall then be hydraulically tested to a pressure of 0.5 N/mm² or twice the working pressure, whichever is greater, for a period of at least 30 min after a steady state is reached. The entire installation shall then be inspected visually for leakages, and sweating. All defects found shall be rectified by removing and remaking the particular section. Caulking of threads, hammering and welding of leaking joints shall not be allowed.

4.15.4.2 Hot water testing

After the system has been proved water-tight, the hot water heaters shall be commissioned by connecting the same to the electrical supply. The system shall then be observed for leakage in pipes due to expansion or overheating. The temperature of water at outlets shall be recorded. The thermostats of the appliances shall be checked and adjusted to temperatures specified in **4.14.2.1**.

4.15.4.3 Electrical connection

For relevant provisions regarding general and safety requirements for household and similar electrical appliances, reference may be made to good practice

[9-1(15)]. The metal work of the water heating appliances and installation other than current carrying parts shall be bonded and earthed in conformity with the good practice [9-1(15)]. It should be noted that screwing of an immersion heater into a tank or cylinder cannot be relied upon to effect a low resistance earth connection, a satisfactory separate earthing of heater should be effected.

4.16 Cleaning and Disinfection of the Supply System

4.16.1 All water mains communications pipes, service pipes and pipes used for distribution of water for domestic purposes shall be thoroughly and efficiently disinfected before being taken into use and also after every major repair. The method of disinfection shall be subject to the approval of the Authority. The pipes shall also be periodically cleaned at intervals, depending upon the quality of water, communication pipes and the storage cisterns shall be thoroughly cleaned at least once every year in order to remove any suspended impurities that may have settled in the pipes or the tanks.

4.16.2 Disinfection of Storage Tanks and Down Take Distribution Pipes

The storage tanks and pipes shall first be filled with water and thoroughly flushed out. The storage tank shall then be filled with water again and a disinfecting chemical containing chlorine added gradually while the tanks are being filled, to ensure thorough mixing. Sufficient quantities of chemicals shall be used to give the water a dose of 50 parts of chlorine to one million parts of water. If ordinary bleaching powder is used, the proportions will be 150 g of powder to 1 000 litre of water. The powder shall be mixed with water to a creamy consistency before being added to the water in the storage tank. When the storage tank is full, the supply shall be stopped and all the taps on the distributing pipes opened successively working progressively away from the storage tank. Each tap shall be closed when the water discharged begins to smell of chlorine. The storage tank shall then be topped up with water from the supply pipe and with more disinfecting chemical in the recommended proportions. The storage tank and pipes shall then remain charged for at least 3 h. Finally, the tank and pipes shall be thoroughly flushed out before any water is used for domestic purposes.

4.17 Water Supply Systems in High Altitudes and/or Sub-Zero Temperature Regions

4.17.1 Selection and Source

In general, the site selected for a water source shall be such as to minimize the length of transmission line so as to reduce the inspection and upkeep. Attempt shall be made, where feasible, to locate the source near the discharge of waste heat, such as of power plants

provided it does not affect the potability of water.

4.17.2 Pumping Installation

Pump and pumping machinery shall be housed inside well-insulated chambers. Where necessary, arrangements shall be made for heating the inside of pump houses. Pump houses, as far as possible, should be built directly above the water intake structures.

4.17.3 Protection of Storage Water and Treatment

Where ambient temperatures are so low as to cause danger of freezing, proper housing, insulation and protection shall be provided for all processes and equipment. If necessary, means shall be provided for proper heating of the enclosure.

4.17.4 Transmission and Distribution

Freezing of the buried pipe may be avoided primarily by laying the pipe below the level of the frost line; well consolidated bedding of clean earth or sand, under, around or over the pipe should be provided. For the efficient operation and design of transmission and distribution work, the available heat in the water shall be economically utilized and controlled. If the heat which is naturally present in water is made equate to satisfy heat losses from the system, the water shall be warmed. Where economically feasible, certain faucets on the distribution system may be kept in a slightly dripping condition so as to keep the fluid in motion and thus prevent is freezing. If found unsuitable for drinking purposes, such water may be used for heating purposes. Heat losses shall be reduced by insulation, if necessary. Any material that will catch, absorb or hold moisture shall not be used for insulation purposes. Adequate number of break pressure water tanks and air release valves shall be provided in the distribution system.

NOTE — The level of frost line is generally found to be between 0.9 m and 1.2 m below ground level in the northern regions of India, wherever freezing occurs.

4.17.4.1 Materials for pipes

Distribution pipes shall be made of any of the following materials conforming to Part 5 'Building Materials' of the Code:

- a) High density polyethylene pipes,
- b) Asbestos cement pipes,
- c) Galvanized iron pipes,
- d) Cast iron pipes,
- e) Copper pipes,
- f) Chlorinated PVC pipes,
- g) Unplasticized PVC pipes (where it is laid before frost line), and
- h) Stainless steel pipes.

4.17.4.2 Materials for insulation of pipes

Insulation of pipes may be provided by wrapping the pipe with fibre glass, mineral wool or closed cell flexible elastomeric foam based insulation materials of desired thickness covered with cladding for protection from damage or from weather in case of external use/pipes laid in exposed conditions; other materials, like 85 percent magnesia, preformed pipe sections, etc, may also be used.

4.17.4.3 Distribution methods

Distribution by barrels or tank trucks shall be employed, where the water requirements are temporary and small. Utmost care shall be exercised for preventing the water from being contaminated by maintaining a residual of disinfecting agent at all times. Hoses, pails and the tank shall be kept free from dust and filth during all period of operation. Where winter temperatures are low, making frost penetration depths greater during the winter and where adequate facilities for heating the water in the distribution system do not exist, the use of tank trucks or barrels for delivery of water shall be considered only for cold weather; during the warm weather, piping system for seasonal use may be supplemented.

4.17.4.4 In the conventional distribution system involving the use of a network of pipelines requiring no auxiliary heat, it is essential that the pipelines are buried well below the frost line. Adequate facilities for draining the pipelines shall be provided where there is a danger of frost.

4.17.4.5 House service connections

House service connections shall be kept operative by the use of adequate insulation at exposed places extending

below the frost line. Figure 7 shows a typical arrangement for providing insulation for house service connections.

4.17.5 For detailed information on planning and designing water supply system peculiar to high altitudes and/or sub-zero temperature regions of the country, reference may be made to good practice [9-1(17)].

4.18 Guidelines to Maintenance

4.18.1 Storage tanks shall be regularly inspected and shall be cleaned out periodically, if necessary. Tanks showing signs of corrosion shall be emptied, thoroughly wire brushed to remove loose material (but not scraped), cleaned and coated with suitable bituminous compositions or other suitable anti-corrosive material not liable to impart taste or odour or otherwise contaminate the water. Before cleaning the cistern, the outlets shall be plugged to prevent debris from entering the pipes. Tanks shall be examined for metal wastage and water tightness after cleaning.

4.18.2 Record drawings showing pipe layout and valve positions shall be kept up to date and inspection undertaken to ensure that any maintenance work has not introduced cross-connections or any other undesirable feature. Any addition or alterations to the systems shall be duly recorded from time-to-time.

4.18.3 Any temporary attachment fixed to a tap or outlet shall never be left in such a position that back-siphonage of polluted water may occur into the supply system.

4.18.4 All valves shall periodically be operated to maintain free movement of the working parts.

4.18.5 All taps and ball valves shall be watertight, glands shall be made good, washers shall be replaced and the mechanism of spring operated taps and ball

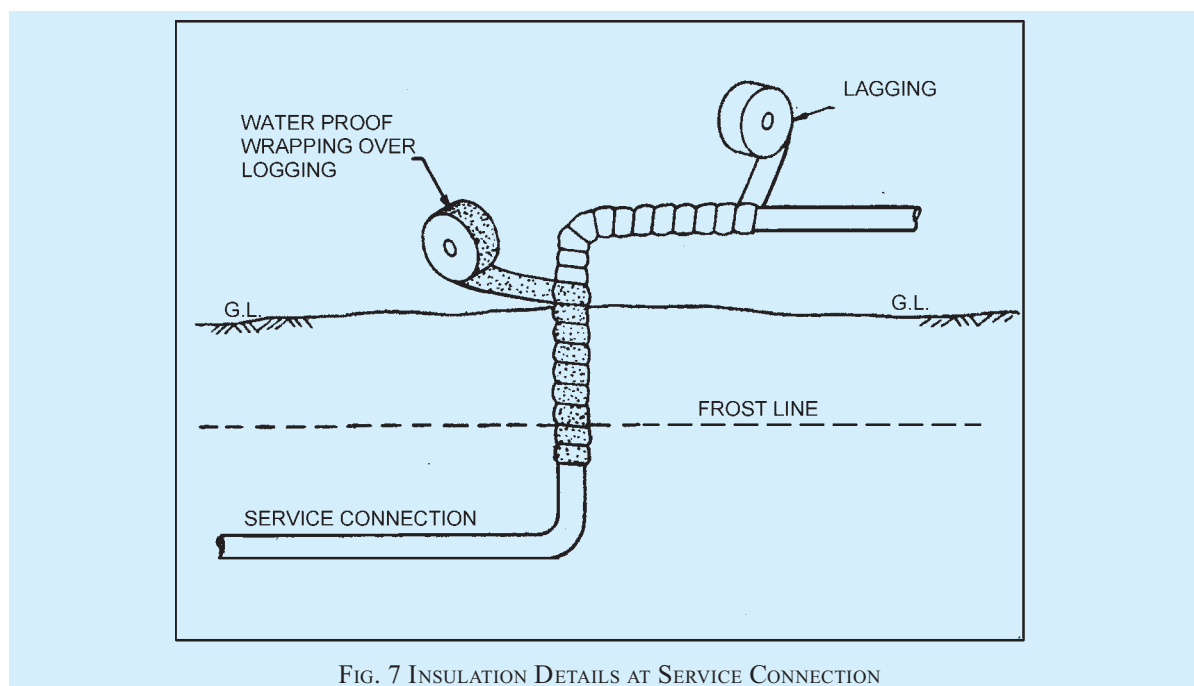

FIG. 7 INSULATION DETAILS AT SERVICE CONNECTION

valves shall be repaired where required.

4.18.6 All overflow pipes shall be examined and kept free from obstructions.

4.18.7 The electrical installation shall be checked for earth continuity and any defects or deficiencies corrected in the case of hot water supply installations.

4.19 Swimming Pools

4.19.1 General

A swimming pool is a container that is filled with water to enable swimming or such other leisure activities. Pools can be sunk into the ground or built above ground (as a freestanding construction or as part of a building or other larger structure), and are also a standard feature aboard ocean liners and cruise ships. In-ground pools are most commonly constructed from materials such as concrete, natural stone, metal, plastic or fiberglass, and can be of a custom size and shape or built to a standardized size.

All pools open to public shall take care of the barrier-free design for accessibility and use by persons with disabilities. Reference shall also be made to **13** of Part 3 ‘Development Control Rules and General building Requirements’ of the Code for applicable requirements.

4.19.1.1 Swimming pools shall be of three types, namely:

Type	Characteristic
Fill and draw	Clear water of potable quality is retained till it becomes turbid or unfit for use. Thereafter, the pool is drained, cleaned and refilled with clear water. This type is not recommended considering water conservation
Flow through	Clear water of hygienic quality flows continuously. This type requires more water for replenishment and so cautious decision of usage of such pools should be made; it is not recommended considering water conservation
Recirculating	Recirculation system shall be provided to minimize water wastage and disinfection shall be done to ensure hygiene. The recirculation system shall be based on the nature of usage such as private, public, wading and competition pools. The entire pool water should be filtered based on the turnover period for various types of pools

4.19.1.2 Turnover rate

It is the amount of time it would take for the volume of the pool to pass through the filtration system one time. Turnover rate is measured in hours and is expressed as:

$$\text{Turnover rate, in h} = \frac{\text{Pool volume (in litre)}}{\text{Flow (in litre/h)}}$$

NOTE— Pool volume comprises volume of the pool water, balancing tank, overflow gutter and circulation pipe.

Typical turnover rates for the following pools are:

Type of Pool	Turnover Rate h
Swimming pool:	
a) Private (outdoor)	6
b) Private (indoor)	10
c) Public	6
d) Competition	6
Wading pool	1
Spa (public)	½
Spa (private)	1

4.19.1.3 Swimming pool user load

The maximum load for the pool shall be:

- a) For pool depth up to 1 m : 2.2 m² surface area per user
- b) For pool depth up to 1.5 m : 2.7 m² surface area per user
- c) For pool depth more than 1.5 m : 4.0 m² surface area per user

4.19.1.4 Recommended dimensions of the swimming pools shall be:

- a) Half sized olympic : 25 m (length) × 12 to 13m (width) × 1.8 m (depth)
- b) Full size olympic : 50 m (length) × 25 m (wide) × 2 m (depth)
- c) Diving depth : 3.5 m for 1 m spring board; and 5 m for a 10 m platform
- d) Maximum depth : See **4.19.2.7**
- e) Ladders : 2 treads for 1.2 m depth; 3 treads for 1.2 m to 1.5 m depth; and 4 treads for 1.5 m depth
- f) Displacement : 60 litre per user for deeper pools; and 45 litre for shallow pools

4.19.2 Design

4.19.2.1 The pool should be so designed to withstand all anticipated hydraulic structural loadings for both full and empty conditions. All appurtenances to the

pool, such as diving boards and slides, shall be designed to carry the anticipated load. Any obstruction creating a safety hazard shall not extend into or above the pool, or shall not protrude from the floor of the pool. Designers may refer good practice [9-1(18)] for providing the guidance on the procedures and the precautions to be taken during construction of swimming pool to ensure the water tightness of the structure.

4.19.2.2 Material

Any suitable material that is non-toxic and provides a rigid watertight shell with a smooth, impervious, light colour finish should be used to construct the pool. The floor of shallow areas shall have a slip-resistant finish. Sand or earth shall not be permitted to use as an interior finish in a swimming pool.

4.19.2.3 Dimensions

The shape and size of a pool largely depend on the usage. Shape should be considered from the standpoint of safety and circulation of the pool water.

NOTES

1 A long and rectangular pool may be ideal for sports and exercise as it gives length and breadth, but the shape of a pool for recreation largely depend on the choice of the owners, available space for making the pool and the design of the house.

2 In sports, normally the swimming pools are 50 m long, minimum 21 m wide and 1.8 m overall depth.

4.19.2.4 Floor slopes

Slope of the floor of the pool should be made downward toward the main drain. All slopes should be uniform. The slope in shallow areas should not exceed 300 mm vertical in 3.6 m horizontal except for a slope directed downward from a transition point, which shall not exceed 300 mm vertical in 1m horizontal. In portions of the pool with a depth greater than 1.5 m, the front slope of the deep area shall not be steeper than 300 mm in 1 m.

4.19.2.5 Transition point

Transition points should be marked with a stripe on the pool floor having a width of at least 100 mm and a colour that contrasts with that of the floor, and with a buoyed safety rope with colour buoys, installed at least 300 mm on the shallow side of the transition point. In other pools having adjoining shallow and deep areas, a safety rope with colour buoys shall be installed where the water depth reaches 1.5 m.

4.19.2.6 Pool walls

Where the pool depth is 1 m or less, pool walls shall be vertical to the floor and the junction of the wall with the floor shall consist of a cove with a radius not exceeding 150 mm. Where the pool depth exceeds 1 m,

pool walls shall meet one of the following criteria:

- a) The wall shall be vertical for a depth of at least 1.5 m below the water level, below which the wall may angle to the floor; or
- b) The wall shall be vertical for a depth of at least 1 m below the water level, below which the wall shall form a curve to the floor. The curve shall be tangent to the pool wall.

4.19.2.7 Water depth

The depth of a swimming pool depends on the purpose of the pool, and whether it is open to the public or strictly for private use. If it is a private casual, relaxing pool, it may go from 1.0 m to 1.5 m deep. If it is a public pool designed for diving, it may slope from 3.5 m to 5.0 m in the deep end. A children's play pool may be from 0.3 m to 0.6 m deep. Public pools may have differing depths to accommodate different swimmer requirements. Water depths may be clearly marked on the pool walls.

The width between handrails of the pool stairs should be between 500 mm and 600 mm.

4.19.2.8 Walkways and deck areas

Pools shall be completely surrounded by a deck that is at least 1.2 m in width and extends completely around and adjacent to the pool. There shall be no obstructions or interruptions of the pool deck within the 1.2 m adjacent to the pool other than necessary structural supports, or appurtenances such as diving boards, slides, perimeter overflow systems, or handrails. A clear, unobstructed walkway at least 1.2 m in width shall be maintained at such obstructions or interruptions. A wheelchair turning space of minimum 1.5 m × 1.5 m shall be provided at key places in the walkway.

Structural supports located within the minimum required deck width or within 1.2 m of the swimming pool shall be no closer than 3 m apart measured parallel to the adjacent perimeter of the pool, with the dimension of any single support in a plane parallel to the adjacent pool perimeter not greater than 1 m and the sum of all such support dimensions not greater than 10 percent of the pool perimeter.

The deck between two adjacent swimming pools shall be at least 2.5 m wide. All decks and walkways shall have an unobstructed overhead clearance of at least 2 m.

Synthetic material which meets the following criteria may be installed for deck coverings:

- a) Non-fibrous and allows drainage such that it will not remain wet or retain moisture;
- b) Inert and will not support bacterial or fungal growth;

- c) Durable;
- d) Cleanable; and
- e) Provides a slip-resistant finish.

The decks and walkways shall have a paved surface. The surface of the pool deck and other surfaces used for foot contact, such as gratings of perimeter overflow systems, shall be slip-resistant.

The outer perimeter of the deck for outdoor pools shall be at least 10 cm higher than the surrounding ground surface except where access is provided to adjacent turf areas.

The pool shall have an accessible entry and exit that is accessible to persons with disabilities. Accessible entry/exit may require provision of a transfer wall or/and a sloped entry with an aquatic chair. Installing a pool lifts may be another option for accessible entry/exit.

The transfer wall should have a minimum clear deck space of 1.5 m × 1.5m, with a slope not steeper than 1:48 at the base of the transfer wall. The height of the transfer wall should be 400 mm to 480 mm from the deck floor. The transfer wall should be 300 mm to 400 mm wide. The length should be minimum 1.5 m centered on the clear deck space. Surfaces of transfer walls shall not be sharp and shall have rounded edges.

A grab bar should be provided on the transfer wall. Grab bars shall be perpendicular to the pool wall and shall extend the full depth of the transfer wall. The top of the gripping surface shall be 100 mm to 150 mm above transfer walls. Clearance of 610 mm should be available on both sides of the grab bar.

4.19.2.9 Starting platforms

Starting platforms may be from 0.50 m to 0.75 m above the surface of water. The maximum height of the platform above the water shall be 0.75 m where the water depth is 1.2 m or greater, and 0.50 m when the water depth is less than 1.2 m. The surface area of each platform shall be 0.5 m × 0.5 m with a maximum slope of not more than 10°. Surface of each block shall be covered with non-slip material and with back stroke hand grip facility.

4.19.3 Electrical Installation

4.19.3.1 Lighting

Artificial lighting shall be provided at all indoor pools and at all outdoor pools that are open for use after sunset in accordance with one of the following:

- a) Underwater lighting of at least 8.35 lumen or 5.5 W/m² of pool water surface area, located to provide illumination of the entire pool floor; plus area lighting of at least 10 lumen or 6.6 W/m² of deck area.

- b) If underwater lights are not provided, at least 33.5 lumen or 2.2 W/m² of pool water surface area and deck area.

Where portable electric vacuum cleaning equipment is used, electrical receptacles with ground-fault circuit interrupter protection shall be provided. Separation between receptacles shall be a maximum of 30 m. All receptacles installed in the swimming pool area shall have waterproof covers and ground-fault circuit interrupter protection. Lighting controls should not be accessible to the public.

4.19.3.2 Ventilation

Adequate ventilation shall be provided in facilities to prevent objectionable odor.

4.19.3.3 Shower and bathroom

Separate shower, dressing booth and sanitary facilities shall be provided for each gender. This may not be applicable for schools and other institutional use where a pool may be open to one gender at a time. The rooms should be well lit, drained, ventilated, and of good construction, using impervious materials. They should be developed and planned to ensure maintenance of good sanitation throughout the building at all times. Floors should have a slip-resistant surface and sufficiently smooth to ensure ease in cleaning.

Each shower and toilet block provided per pool, open for use by public, shall have a unisex accessible shower, dressing-cum-toilet facility for persons with disabilities. Design specifications of this accessible facility shall be as per 13 of Part 3 'Development Control Rules and General Building Requirements' of the Code.

4.19.4 Water Treatment System

4.19.4.1 General

A water treatment system shall be provided to filter, chemically balance and disinfect the swimming pool water.

4.19.4.2 Hair and lint strainer

A hair and lint strainer shall be installed on the suction side of the pump except on vacuum filter systems. The strainer basket shall be easily removable. Valves shall be installed to allow the flow to be shut off during cleaning, switching baskets or inspection.

4.19.4.3 Inlets

Inlets for filtered water shall be located and directed suitably to produce uniform circulation of water to facilitate the maintenance of a uniform disinfectant residual throughout the entire pool without the existence of dead spots, and to produce surface flow patterns that effectively assist skimming.

4.19.4.4 Outlets

Pools shall be provided with a minimum of two drains (outlets) at the deepest point. Centre-to-centre distance between drains shall not exceed 2.0 m. Drains shall not be more than 3.0 m away from the pool walls. The main drain may be connected to the recirculation system. Openings shall be covered by grating which cannot be removed without the use of tools. Openings of the grating shall be at least four times the area of the main drain pipe or have an open area. The maximum width of grate openings shall not exceed 8 mm. Main drains and all other suction outlets installed in the pool shall be designed to prevent bather entrapment and shall be of anti-vortex type. The velocity at outlet pipe shall not be more than 0.3 m/s.

4.19.4.5 Velocities

Maximum permissible velocities for various components of the pools are as follows:

- a) Suction pipe — less than 1.5 m/s
- b) Return pipe — 1.5 to 2 m/s
- c) Return/inlet fittings — 2.4 to 2.75 m/s in private pools and 1.5 to 2 m/s in public pools

4.19.4.6 Balancing (surge) tank

Overflow system shall be designed for effective surge capacity. Balancing tank should be provided of capacity to accommodate surge storage and storage for make up water. The volume of the balancing tank shall be the total of the above with equal proportions.

4.19.4.7 Make-up water

Make-up water shall be added through a fixed air gap of at least 15 cm to the pool, surge tank, vacuum filter tank, or other receptacle. When make-up water is added directly to the pool, the fill-spout should be located under a low diving board or immediately adjacent to a ladder rail, grab rail, or fixed lifeguard chair.

4.19.4.8 Filtration

The design filtration rate in the particular application in which the filter is utilized shall not exceed the maximum design filtration rate for which the filter was installed. Wash or backwash water from diatomaceous earth filters shall be passed through a separation tank designed for removal of suspended diatomaceous earth and solids, prior to disposal.

NOTE — Filtration rates for various types of filters are:

- a) Low rate filter — 10 m³/m²/h
- b) Medium rate filter — 11 to 30 m³/m²/h
- c) High rate filter — 31 to 50 m³/m²/h
- d) Minimum flow rate for filter back wash — 30 m³/m²/h

4.19.4.9 Disinfection

The pool water shall be continuously disinfected by suitable disinfecting agent that imparts easily measured residual. Gaseous chlorine, chlorine compounds, bromine compounds or other bactericidal agents should be used to maintain the quality parameters of water.

4.19.5 Water Quality

4.19.5.1 Disinfectant residual

Where chlorine is used as a disinfectant, the chlorine residual shall be maintained between 1.0 and 4.0 ppm, as free chlorine residual. A free chlorine residual of at least 2.0 ppm shall be maintained when the pool water temperature exceeds 30°C.

Where bromine is used as a disinfectant, a bromine residual shall be maintained between 2.0 and 8.0 ppm as total bromine. A bromine residual of at least 4.0 ppm shall be maintained when the pool water temperature exceeds 30°C.

Where chlorinated cyanurates are used, the cyanuric acid concentration shall not exceed 100 ppm.

Where silver/copper or copper ion generators are used, the concentration of copper shall not exceed 1.3 ppm and the concentration of silver shall not exceed 0.05 ppm.

Where ozone is used, the ambient air ozone concentration shall be less than 0.1 ppm, at all times either in the vicinity of the ozonator or at the pool water surface.

For all other physical, chemical and bacteriological parameters, the quality of water used in swimming pools in continuous circulation type shall conform to good practices [9-1(19)].

4.20 Allowance for Expansion

4.20.1 The allowances for expansion of the water pipes are recommended as given below:

- a) All pipes should be installed at ambient temperature.
- b) Pipes carrying hot fluids such as water or steam operate at higher temperatures. It follows that they expand, especially in length, with an increase from ambient to working temperatures. This will create stress upon certain areas within the distribution system, such as pipe joints, which, in the extreme, could cause fracture.
- c) The pipe work system shall be sufficiently flexible to accommodate the movements of the components as they expand. In many cases, the flexibility of the pipe work system, due to the length of the pipe and number of bends and supports, means that no undue stresses are imposed. In other installations, however, it will be necessary to incorporate some means of achieving this required flexibility.
- d) The expansion fitting is one method of accommodating expansion. These fittings are placed within a line and are designed to accommodate the expansion without the total length of the line changing. They are commonly called expansion bellows, due to the bellows construction of the expansion sleeve.

- e) Other expansion fittings can be made from the pipe work itself. This can be a cheaper way to solve the problem, but more space is needed to accommodate the pipe.

4.20.2 Full Loop

- a) This is simply one complete turn of the pipe and, on steam pipe work, should preferably be fitted in a horizontal rather than a vertical position to prevent condensate accumulating on the upstream side.
- b) The downstream side passes below the upstream side and great care shall be taken that it is not fitted wrong way round, as condensate can accumulate in the bottom.

When full loops are to be fitted in a confined space, care shall be taken to specify that wrong-handed loops are not supplied.

- c) The full loop does not produce a force in opposition to the expanding pipe work as in some other types, but with steam pressure inside the loop, there is a slight tendency to unwind, which puts an additional stress on the flanges.

4.21 Colour Codes for Different Types of Water Pipes

The following colour codes are recommended for pipes {see also accepted standard [9-1(20)]}:

<i>Sl No.</i> (1)	<i>Particulars</i> (2)	<i>Ground Colour</i> (3)	<i>First Colour Band</i> (4)	<i>Second Colour Band</i> (5)
i)	Cooling water	Sea green	French blue	—
ii)	Boiler feed water	Sea green	Gulf red	—
iii)	Condensate water	Sea green	Light brown	—
iv)	Drinking	Sea green	French blue	Signal red
v)	Treated	Sea green	Light orange	—
vi)	Fire water	Fire red	Crimson red	—
vii)	Water with central heating below 60°C	Sea green	Canary yellow	—
viii)	Water with central heating between 60 to 100°C	Sea green	Dark violet	—
ix)	Water with central heating above 100°C	Sea green	Dark violet	Signal red
x)	Cold water from storage tanks	Sea green	French blue	Canary yellow
xi)	Domestic, hot water	Sea green	Light grey	—
xii)	Hydraulic power water	Sea green	Black	—
xiii)	Untreated sea/river water	Sea green	white	—
xiv)	Filtered water	Sea green	Light brown	—
xv)	Soft water	Sea green	Light brown	Signal red
xvi)	Warm water	Sea green	Light grey	Canary yellow
xvii)	Chilled water	Sea green	Black	Canary yellow
xviii)	Sprinkler and hydrant water	Sea green	White	Signal red
xix)	Waste water	Sea green	Canary yellow	Signal red

ANNEX A
(Clause 3.2.1)

APPLICATION FORM FOR TEMPORARY/PERMANENT SUPPLY OF WATER/FOR ADDITIONS AND/OR ALTERATIONS FOR SUPPLY OF WATER

I/Wehereby make application to the* for the temporary/permanent supply of water for the following additions and/or alterations to the water supply requirements and water fittings at the premises..... Ward No.Street No.Road/Street known asfor the purpose described below and agreed to pay such charges as the Authority may from time-to-time be entitled to make and to conform to all their byelaws and regulations.....licensed/registered plumber, has been instructed by me/us to carry out the plumbing work.

Description of the premises:.....

Address :.....

Purpose for which water is required.....

.....

The connection/connections taken by me/us for temporary use, shall not be used by me/us for permanent supply unless such a permission is granted to me/us in writing by the Authority.

I/We hereby undertake to give the* due notice of any additions or alterations to the above mentioned supply which I/we may desire to make.

My/Our requirements of water supply are as under:

- a) I/We request that one connection be granted for the whole of the premises.
- b) I/We request that separate connections may be granted for each floor and I/we undertake to pay the cost of the separate connections.
- c) My/Our probable requirements for trade purpose arelitre per day and for domestic purposes are.....litre per day.
- d) Our existing supply islitre per day. Our additional requirement of supply islitre per day.
- e) The details as regards proposed additions and alterations in fittings are as follows:

.....
.....

Signature of the licensed/registered plumber.....

Signature of the applicant.....

Name and address of the licensed/registered

Name and address of the

Plumber.....

Applicant

Date

Date

NOTES

- 1 Please strike out whatever is not applicable.
- 2 The application should be signed by the owner of the premises or his constituted attorney and shall be countersigned by the licensed/registered plumber.

* Insert here the name of the Authority.

ANNEX B
(Clause 3.2.3)

FORM FOR LICENSED/REGISTERED PLUMBER'S COMPLETION CERTIFICATE

Certified that I/we have completed the plumbing work of water connection No..... for the premises as detailed below. This may be inspected and connection given.

Ward No..... Road/Street.....
 Locality.....
 Block No..... House No.....
 Existing water connection No. (if any).....
 Owned by.....
 Owner's address.....
 Applicant's name..... Son of.....
 Address.....
 Situation.....
 Size of main.....on..... street
 Where main is situated.....
 Size of service pipe.....
 Size of ferrule.....
 No. of taps..... No. of closets.....
 No. of other fittings and appliances.....
 Road cutting and repairing fee

Paid Rs.....(Receipt No.....dated.....) (receipt enclosed)

Dated Signature of licensed/registered plumber.....
 Name and address of the licensed/registered plumber

The Authority's Report

Certified that the communication and distribution pipes and all water fittings have been laid, applied and executed in accordance with the provisions of bye-laws, and satisfactory arrangements have been made for draining off waste water.

Connection will be made on.....

Date..... The Authority.....

ANNEX C (Clause 4.7.4)

NOMOGRAM OF HAZEN AND WILLIAM'S EQUATION

C-1 Examples of the use of nomogram are given below:

Example 1

Find the total friction loss in 25 mm diameter G.I. pipe discharging 0.25 litre/s in a total length of 300 m.

Procedure

- Discharge, Q = 0.25 litre/s
- Pipe diameter = 25 mm
- Frictional loss (from nomogram) = 30 m per 1 000 m
- Total friction loss in 300 m length = $\frac{30}{100} \times 300 = 9\text{m}$

Example 2

Find suitable diameter pipe to carry 15 litre/s from service line to overhead tank.

Total length of service main = 200 m

Residual pressure available at the take off point on supply line is 15 m.

Procedure

- Available head = 15 m
- Deduct residual head = 2 m
- Deduct 10 percent for losses in bends and specials = 1.3 m
- Friction head available for loss in pipe of 1 000 m = $\frac{11.7}{200} \times 1\ 000 = 58.5\text{ m per }1\ 000\text{ m}$

From the nomogram, for a discharge of 15 litre/s and friction loss of 58.5 m per 1 000 m, nearest commercial size (diameter) of pipe is 100 mm.

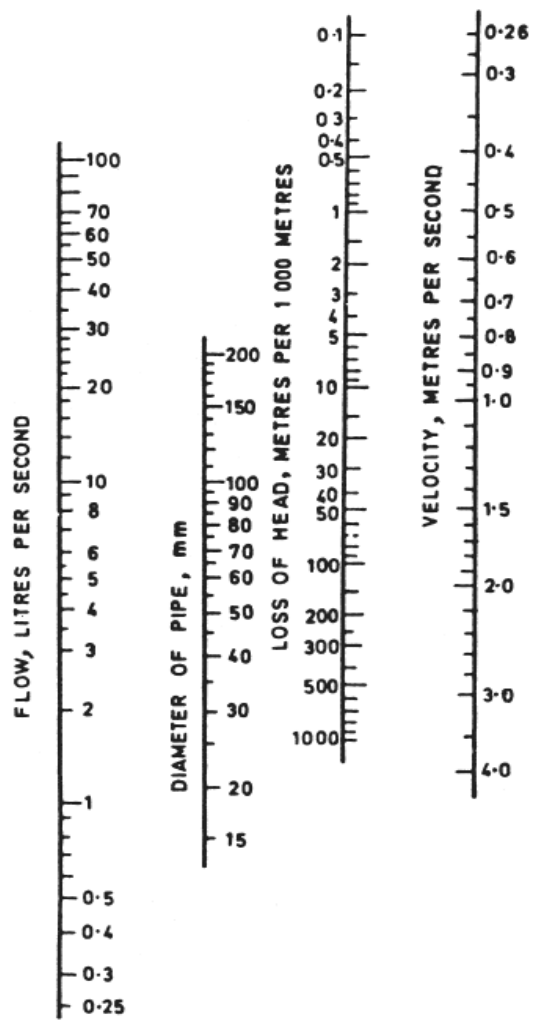

Nomogram of Hazen and Williams Equation (c = 100)

LIST OF STANDARDS

The following list records those standards which are acceptable as 'good practice' and 'accepted standards' in the fulfillment of the requirements of the Code. The latest version of a standard shall be adopted at the time of enforcement of the code. The standards listed may be used by the Authority for conformance with the requirements of the referred clauses in the Code.

In the following list, the number appearing in the first column within parantheses indicates the number of the reference in this Section.

<i>IS No.</i>	<i>Title</i>	<i>IS No.</i>	<i>Title</i>
(1) 10446 : 1983	Glossary of terms relating to water supply and sanitation	(Part 1) : 1975	Choice of materials and general recommendations
(2) 11208 : 1985	Guidelines for registration of plumbers	(Part 2) : 2012	Laying and jointing of polyethylene (PE) pipes (<i>first revision</i>)
(3) 10500 : 2012	Specification for drinking water (<i>second revision</i>)	(Part 3) : 2003	Laying and jointing of UPVC pipes (<i>first revision</i>)
(4) 2041 : 2009	Specification for steel plates for pressure vessels used at moderate and low temperature (<i>third revision</i>)	(13) 783 : 1985	Code of practice for laying of concrete pipes (<i>first revision</i>)
804 : 1967	Specification for rectangular pressed steel tanks (<i>first revision</i>)	3114 : 1994	Code of practice for laying of cast iron pipes (<i>second revision</i>)
(5) 4984 : 1995	Specification for high density polyethylene pipes for potable water supplies (<i>fourth revision</i>)	5822 : 1994	Code of practice for laying of welded steel pipes for water supply (<i>second revision</i>)
4985 : 2000	Specification for unplasticized PVC pipes for potable water supplies (<i>third revision</i>)	6530 : 1972	Code of practice for laying of asbestos cement pressure pipes
15778 : 2007	Specification for chlorinated polyvinyl chloride (CPVC) pipes for portable hot and cold water distribution supplies	7634	Code of practice for plastics pipes selection, handling, storage and installation for potable water supplies
(6) 2065 : 1983	Code of practice for water supply in buildings (<i>second revision</i>)	(Part 1) : 1975	Choice of materials and general recommendations
(7) 3114 : 1994	Code of practice for laying of cast iron pipes (<i>second revision</i>)	(Part 2) : 2012	Laying and jointing of polyethylene (PE) pipes (<i>first revision</i>)
(8) 782 : 1978	Specification for caulking lead (<i>third revision</i>)	(Part 3) : 2003	Laying and jointing of UPVC pipes (<i>first revision</i>)
(9) 5822 : 1994	Code of practice for laying of welded steel pipes for water supply (<i>second revision</i>)	(14) 2692 : 1989	Specification for ferrules for water services (<i>second revision</i>)
(10) 6530 : 1972	Code of practice for laying of asbestos cement pressure pipes	(15) 302 (Part 1) : 2008	Safety of household and similar electrical appliances: Part 1 General requirements (<i>sixth revision</i>)
(11) 783 : 1985	Code of practice for laying of concrete pipes (<i>first revision</i>)	2082 : 1993	Stationary storage type electric water heaters (<i>third revision</i>)
(12) 7634	Code of practice for plastics pipes selection, handling, storage and installation for potable waters supplies:	(16) 7558 : 1974	Code of practice for domestic hot water installations
		(17) 6295 : 1986	Code of practice for water supply and drainage in high altitudes and/or sub-zero temperature regions (<i>first revision</i>)
		(18) 6494 : 1988	Code of practice for water-proofing of underground water reservoirs and swimming pools (<i>first revision</i>)
		(19) 3328 : 1993	Quality tolerances for water for swimming pools
		(20) 2379 : 1990	Colour code for identification of pipe lines

NATIONAL BUILDING CODE OF INDIA

PART 9 PLUMBING SERVICES (INCLUDING SOLID WASTE MANAGEMENT)

Section 2 Drainage and Sanitation

BUREAU OF INDIAN STANDARDS

CONTENTS

FOREWORD	...3
1 SCOPE	...5
2 TERMINOLOGY	...5
3 GENERAL	...13
4 DRAINAGE AND SANITATION	...15
ANNEX A APPLICATION FOR DRAINAGE OF PREMISES	...63
ANNEX B FORM FOR DETAILED DESCRIPTION OF WORK AND SPECIFICATION OF MATERIALS	...63
ANNEX C FORM FOR LICENSED/REGISTERED PLUMBER'S COMPLETION CERTIFICATE	...66
ANNEX D TYPICAL MOUNTING ARRANGEMENTS FOR VARIOUS PLUMBING FIXTURES, INCLUDING DRAINAGE SYSTEMS AND VENTILATION	...67
LIST OF STANDARDS	...80

FOREWORD

This Code (Part 9/Section 2) covers the drainage and sanitation requirements of buildings, design, layout, construction and maintenance of drains inside buildings and from the buildings up to the connection to public sewer, private sewer, individual sewage disposal system, cesspool, or to other approved point of disposal/treatment work. It also covers drainage systems peculiar to high altitudes and/or sub-zero temperature regions of the country.

In the first version of the Code formulated in 1970, three separate sections of Part 9 Plumbing services, were brought out, namely, Section 1 Water Supply, Section 2 Drainage and Sanitation, and Section 3 Gas Supply. These sections were subsequently revised in 1983.

The major changes incorporated in the first revision in Section 2 Drainage and sanitation were rationalization of definitions; modification of the requirements for fitments for drainage and sanitation in the case of buildings other than residences; addition of table for sanitation facilities in fruit and vegetable markets; introduction of table giving detailed guidance regarding the selection of plumbing system, depending on the nature of drainage load in buildings and height of buildings; amplification of provision relating to safeguards to be adopted in single stack system; modification of the values of gradients, pipe sizes and the corresponding discharges; rationalization of sizes of manholes/inspection chambers; modification of the sizing of rainwater pipe for roof drainage, to take into account rainfall intensities and recommend sizes on a more rational basis; addition of provisions for drainage and sanitation system peculiar to high altitudes and/or sub-zero temperature regions of the country; and inclusion of requirements of the refuse chute system.

As a result of experience gained in implementation of 1983 version of the Code and feedback received as well as revision of some of the standards based on which this Section was prepared, a need to revise this Section was felt. The last revision was therefore prepared to take care of these. In the last revision, the erstwhile two Sections were merged and a combined and comprehensive section, namely Section 1 Water supply, drainage and sanitation (including solid waste management), was brought out. Gas supply was brought out as Section 2. Following significant changes were incorporated in the last revision of Section 1 on Water supply, drainage and sanitation, in respect to drainage and sanitation: rationalization and addition of new definitions under terminology; enunciation of certain basic principles for water supply and drainage; addition of a new clause on sanitary appliances; updation of Tables 1 to 14 of the existing version, regarding drainage and sanitation requirement; addition of additional requirements under layout clause of design considerations; modification and rationalization of provisions regarding choice of plumbing systems; addition of new clause on drain appurtenances having details on trap, floor drain and cleanout; incorporation of provisions on indirect wastes, special wastes (covering laboratory wastes, infected wastes, research laboratory wastes, etc), grease traps, oil interceptors, radio-active wastes, etc; revision of manhole details on size and enhancement of construction clause; inclusion of provisions on rainwater harvesting; revision of the minimum rainfall intensity which is drain design basis for discharge of storm water drain into a public storm water drain, to 50 mm/h; modification of the table for sizing of rainwater pipes for roof drainage, with inclusion of rainfall data which were not available in the earlier version; inclusion of figure on detail of subsoil drainage; and addition of details on support/protection of pipes.

The last revision also incorporated for the first time the provisions on solid waste management.

In this revision to comprehensively address the various and distinct features related to the plumbing aspects, this Part 9 has been rearranged as follows:

- Section 1 Water supply
- Section 2 Drainage and sanitation
- Section 3 Solid waste management
- Section 4 Gas supply

Further, in this revision of the Section 2, following significant changes/modifications have been incorporated:

- 1) Various tables on the requirements for fitments for drainage and sanitation for various occupancies have been updated, and a new table for shopping malls and retail buildings has been included.
- 2) Enabling provisions for use of corrugated pipes, low noise pipes and under slung pipes have been included.
- 3) Information about bio-toilets has been added.
- 4) Typical mounting arrangements for various plumbing fixtures, including drainage systems and ventilation have been illustrated.
- 5) A new table for calculation of single stack sizing has been included.
- 6) Various additional requirements relating to layout of drainage and sanitation system have been added.
- 7) Venting system for high rise buildings, along with a comprehensive table on size and developed length of stack vents and vent stacks, has been included.
- 8) General provisions on design of drainage pipes have been elaborated.
- 9) Provisions relating to gradients of drainage pipes have been elaborated.
- 10) The table on fixture unit for different types of fixtures has been updated.
- 11) The tables on maximum number of fixture units that can be connected to branches and stacks, and to building drains and sewers, have been updated.
- 12) New provisions on design requirement for high rise buildings drainage system have been included.
- 13) The minimum diameter for floor drains outlets before connecting to floor trap has been included.
- 14) Provisions related to manhole covers and recommended locations have been included.
- 15) Provision for estimation of storm water runoff and coefficient of runoff for various surfaces have been included.
- 16) The table on sizing of rainwater pipes for roof drainage has been updated.
- 17) The illustration on artificial ground water recharge structure has been detailed.
- 18) Guidelines relating to siphonic drainage system for large roofs have been included.
- 19) Provisions on rainwater harvesting for plotted/group housing developments and deep well/bore well recharging, have been included.
- 20) Clarifications and recommendations on use of septic tanks have been made.
- 21) New provisions related to pumping and treatment of sewage have been included.
- 22) A provision on treatment of waste water and usage of recycled water has been included through cross-reference to Section 1 'Water supply' of this Part of the Code.
- 23) Provisions have been reviewed and updated from the point of view of accessibility by elderly and persons with disabilities, also, in this context, duly giving cross-reference to 13 of Part 3 'Development Control Rules and General Building Requirements' of the Code.
- 24) Certain terminologies have been included and some have been updated.
- 25) Cross-referred standards have been updated.

This Section is largely based on the following Indian Standards:

IS 1742 : 1983	Code of practice for building drainage (<i>second revision</i>)
IS 4111 (Part 1) : 1986	Code of practice for ancillary structures in sewage system: Part 1 Manholes (<i>first revision</i>)
IS 5329 : 1983	Code of practice for sanitary pipe work above ground for buildings (<i>first revision</i>)
IS 6295 : 1986	Code of practice for water supply and drainage in high altitudes and or sub-zero temperature regions (<i>first revision</i>)

A reference to SP 35:1987 'Handbook on Water Supply and Drainage' may be useful, from where also, assistance has been derived.

All standards, whether given herein above or cross-referred to in the main text of this Section, are subject to revision. The parties to agreement based on this section are encouraged to investigate the possibility of applying the most recent editions of the standards.

In the formulation of this Section, reference has also been made to the following:

International Plumbing Code 2015, International Code Council, and

Uniform Plumbing Code 2015, International Association of Plumbing and Mechanical Officials

For the purpose of deciding whether a particular requirement of this Section is complied with, the final value, observed or calculated, expressing the result of a test or analysis, shall be rounded off in accordance with IS 2 : 1960 'Rules for rounding off numerical values (*revised*)'. The number of significant places retained in the rounded off value should be the same as that of the specified value in this Section.

NATIONAL BUILDING CODE OF INDIA

PART 9 PLUMBING SERVICES (INCLUDING SOLID WASTE MANAGEMENT)

Section 2 Drainage and Sanitation

1 SCOPE

1.1 This Code (Part 9/Section 2) covers the design, layout, construction and maintenance of drains for foul water, surface water, subsoil water and sewage together with all ancillary works, such as connections, manholes and inspection chambers used within the building and from building to the connection to a public sewer, private sewer, individual sewage-disposal system, cess-pool, soakaway or to other approved point of disposal/treatment work.

NOTE — A sanitary drainage system consists of a building sewer, a building drain, a soil and/or waste stack, horizontal branches or fixture drain, and vents. The sanitary drainage of a large building may have a number of primary and secondary branches, and several soil and/or waste stacks, each of them in turn may have a number of horizontal branches.

2 TERMINOLOGY

For the purpose of this Section, the following definitions shall apply in addition to the definitions given in accepted standards [9-2(1)].

2.1 Air Admittance Valve — One way valves designed to allow air to enter drainage system when negative pressure develops in the system. The purpose is to provide a method of allowing air to enter the drainage system for prevention of siphonage of traps.

2.2 Air Break — Physical separation which may be a low inlet into the indirect waste receptor from the fixture or device indirectly connected.

2.3 Air Gap, Drainage — Unobstructed vertical distance through the free atmosphere between the lowest opening from any pipe, plumbing fixture or appurtenance conveying waste to flood level of the receptor.

2.4 Back Up — A condition where the waste water may flow back into another fixture or compartment but not back into the potable water system.

2.5 Back Water Valve — Device installed in a drainage system to prevent reverse flow.

2.6 Bath Room Group — Group of fixtures consisting of water closet, lavatories bath tub or shower and other fittings with a floor drain located together.

2.7 Battery of Fixtures — Any group of two or more similar adjacent fixtures which discharge into a common horizontal waste or soil pipe.

2.8 Bed Pan Washer — A washer which is to be used for disposing human waste and sterilizing the Bed Pan for reuse. Bed pan washer requires water connection and electrical heating arrangement. This is to be considered as soil appliance.

2.9 Benching — Sloping surfaces constructed on either side of channels at the base of a manhole or inspection chamber for the purpose of confining the flow of sewage, avoiding the accumulation of deposits and providing a safe working platform.

2.10 Branch

- a) Special form of sewer pipe used for making connections to a sewer or water main. The various types are called 'T', 'Y', 'T-Y', double Y and V branches, according to their respective shapes.
- b) Any part of a piping system other than a main or stack.

2.11 Branch Soil Pipe (BSP) — A pipe connecting one or more soil appliances to the main soil pipe.

2.12 Branch Soil Waste Pipe (BSWP) — A pipe connecting one or more soil and/or waste appliances to the main soil waste pipe (one pipe system).

2.13 Branch Vent Pipe (BVP) — A pipe, one end of which is connected to the system adjacent to the trap of an appliance and the other to a main vent pipe or a drain-vent pipe. It is fitted to prevent loss of water seal from a trap owing to partial vacuum, back-pressure, or surging caused by air movement within the pipe system. It also provides ventilation for the branch waste pipe.

2.14 Branch Waste Pipe (BWP) — A pipe connecting one or more waste appliances to the main waste pipe.

2.15 Building Drain-Combined — A building drain which conveys both sewage and storm water or other drainage.

2.16 Building Drain-Sanitary — A building drain which conveys sewage and sullage only.

2.17 Building Drain-Storm — A building drain which conveys storm water or other drainage but no sewage or sullage.

2.18 Building Sewer — That part of the horizontal piping of a drainage system which extends from the end of the building drain and which receives the discharge of the building drain and conveys it to a public sewer, private sewer, individual sewage-disposal system or approved point of disposal.

2.19 Building Sub-Drain — That portion of a drainage system which cannot drain by gravity in the building sewer.

2.20 Building Trap — A device, fitting or assembly of fittings installed in the building drain to prevent circulation of air between the drainage of the building and the building sewer. It is usually installed as running trap.

2.21 Cesspool

- a) An underground chamber for the reception and storage of foul water, the contents of which are periodically removed for disposal.
- b) A box-shaped receiver constructed in a roof or gutter for collecting rainwater which then passes into a rainwater pipe connected thereto.

2.22 Cleaning Eye — An access opening in a pipe or pipe fitting arranged to facilitate the cleaning of obstructions and fitted with removable cover.

2.23 Clear Waste Water — Cooling water and condensate drainage from refrigeration and air conditioning equipment, cooled condensate from steam heating systems, cooled boiler blow-down water, waste water drainage from equipment rooms and other areas where water is used without an appreciable addition of oil, gasoline, solvent, acid, etc, and treated effluent in which impurities have been reduced below a minimum concentration considered harmful.

2.24 Collection Chamber — A compartment situated at the lower end of the chute for collecting and housing the refuse during the period between two successive cleanings.

2.25 Connection — The junction of a foul water drain, surface water drain or sewer from building or building with public sewer treatment works, public sewer, private sewer, individual sewage-disposal system, cess-pool, soakaway or to other approved point of disposal/treatment work.

2.26 Consumer — Any person who discharges waste or sewage to the public sewer installed by the Authority.

2.27 Crown of Trap — The topmost point of the inside of a trap outlet.

2.28 Deep Manhole — A manhole of such depth that an access shaft is required in addition to the working chamber.

2.29 Depth of Manhole — The vertical distance from the top of the manhole cover to the outgoing invert of the main drain channel.

2.30 Developed Length — The length measured along the centre line of a pipe and fittings.

2.31 Diameter — The nominal internal diameter of pipes and fittings.

2.32 Drain — A conduit, channel or pipe for the carriage of storm water, sewage, waste water or other water-borne wastes in a building drainage system.

2.33 Drain Vent Pipe (DVP) — A pipe installed to provide flow of air to or from a drain to prevent undue concentration of foul air in the drain. The main soil pipe or main waste pipe may serve as drain vent pipe wherever their upper portions, which do not receive discharges, are extended to the roof level and let open to air.

2.34 Drainage — The removal of any liquid by a system constructed for the purpose.

2.35 Drainage Fixture Unit (DFU) — A measure of probable discharge into the drainage system by various types of plumbing fixtures. The drainage fixture unit value for a particular fixture depends on its volume rate of drainage discharge, on the time duration of a single drainage operation and on the average time between successive operations.

2.36 Drainage Work — The design and construction of a system of drainage.

2.37 Drop Connection — A length of conduit installed vertically immediately before its connection to a sewer or to another drain.

2.38 Drop Manhole — A manhole installed in a sewer where the elevation of the incoming sewer considerably exceeds that of the outgoing sewer; a vertical waterway outside the manhole is provided to divert the waste from the upper to the lower level so that it does not fall freely into the manhole except at peak rate of flow.

2.39 Eco-toilet (or Bio-toilet) — The dry toilet that uses a predominantly aerobic processing system to treat human excreta, by composting or managed-aerobic decomposition. It generally uses little to no water and may be used as an alternative to flush toilets.

2.40 Fittings — The appurtenances such as coupling, flange, branch, bend, tees, elbows, unions, waste (with or without plug), P or S trap (with or without vent), stop ferrule, bib tap, pillar tap, bath faucet, water meter, garden hydrant, valves and any other article used in connection with water supply, drainage and sanitation.

2.41 Fixture Unit — A quantity in terms of which the load producing effects on the plumbing system of different kinds of plumbing fixtures is expressed on some arbitrarily chosen scale.

2.42 Formation — The finished level of the excavation at the bottom of a trench or heading prepared to receive the permanent work.

2.43 French Drain or Rubble Drain — A shallow trench filled with coarse rubble, clinker, or similar material with or without field drain pipes.

2.44 Frost Line — The line joining the points of greatest depths below ground level up to which the moisture in the soil freezes.

2.45 Grease Interceptor (or Grease Trap) — A chamber, on the line of a drain or waste pipe, for preventing grease from passing into the drainage system. It reduces non-petroleum fats, oils and grease in effluent by separation and volume reduction to improve sewage treatment efficiency.

As it is used to intercept fats, oils and grease (FOG) from a waste water discharge, it is also known as FOG interceptor.

2.46 Gully Chamber — The chamber built of masonry round a gully trap for housing the same.

2.47 Gully Trap — A trap provided in a drainage system with a water seal fixed in a suitable position to collect waste water from the scullery, kitchen sink, wash basins, baths and rainwater pipes.

2.48 High Altitudes — Elevations higher than 1 500 m above mean sea level (MSL).

2.49 Highway Authority — The public body in which is vested, or which is the owner of, a highway repairable by the inhabitants collectively; otherwise the body or persons responsible for the upkeep of the highway.

2.50 Horizontal Pipe — Any pipe of fitting which makes an angle of more than 45° with the vertical.

2.51 Indirect Waste Pipe — The pipe that does not connect directly with the drainage system, but conveys liquid wastes by discharging into a plumbing fixture/interceptor that is directly connected to the drainage system.

2.52 Inlet Fittings — An arrangement of connecting the internal waste branch pipe from wash basin, sinks and shower drains to the main deep seal trap with the help of hopper extension.

2.53 Inlet Hopper — A receptacle fitting for receiving refuse from each floor and dropping it into the chute.

2.54 Insanitary — Condition that is contrary to sanitary principles or is injurious to health.

2.55 Inspection Chamber — A water-tight chamber constructed in any house-drainage system which takes wastes from gully traps and disposes to manhole with access for inspection and maintenance.

2.56 Interceptor — A device designed and installed so as to separate and retain deleterious, hazardous or undesirable matter from normal wastes and permit

normal sewage or liquid wastes to discharge into the disposal terminal by gravity.

2.57 Interceptor Manhole or Interceptor Chamber — A manhole incorporating an intercepting trap and providing means of access thereto.

2.58 Invert — The lowest point of the internal surface of a pipe or channel at any cross-section.

2.59 Junction Pipe — A pipe incorporating one or more branches.

2.60 Lagging — Thermal insulation or pipes.

2.61 Licensed (or Registered) Plumber — A person licensed (or registered) under the provisions of this Code.

2.62 Main Soil Pipe (MSP) — A pipe connecting one or more branch soil pipes to the drain.

2.63 Main Soil and Waste Pipe (MSWP) — A pipe connecting one or more branch soil and waste pipes to the drain.

2.64 Main Vent Pipe (MVP) — A pipe which receives a number of branch vent pipes.

2.65 Main Waste Pipe (MWP) — A pipe connecting one or more branch waste pipes to the drain.

2.66 Manhole — An opening by which a man may enter or leave a drain, a sewer or other closed structure for inspection, cleaning and other maintenance operations, fitted with suitable cover.

2.67 Manhole Chamber — A Chamber constructed on a drain or sewer so as to provide access thereto for inspection, testing or clearance of obstruction.

2.68 Offset — A pipe fitting used to connect two pipes whose axes are parallel but not in line.

2.69 Pipe System — The system to be adopted will depend on the type and planning of the building in which it is to be installed and will be one of the following:

- a) *Single stack system* (see Fig. 1) — The piping system in which there is no trap ventilation and the stack itself acts as vent through roof. In this system care shall be taken for proper sizing of the pipes and the trap arm distance, specially the horizontal distance of sanitary fixtures from the drainage stack and vertical distance between connection of branches from fixtures to drainage stack.
- b) *One pipe — Partially ventilated system* (see Fig. 2) — The piping system in which soil and waste pipes are connected to a single vertical stack [as explained in 2.69 (a)] with additional vent pipe for ventilation of traps of water closets. It is also sometimes known as single stack — partially ventilated system.

- c) **One pipe — Fully ventilated system** (see Fig. 3) — The piping system in which the waste pipes from the sinks, baths and wash basins, and the soil pipe from water closet are connected to a single vertical stack. The traps of the water closets, waste appliances, etc, are individually ventilated and connected with a separate stack to preserve the water seal. It is also sometimes known as single stack — fully ventilated system.
- d) **Two pipe system**
- 1) **Two pipe system with common vent pipe** (see Fig. 4A) — The piping system in which all soil appliances such as water closets, urinals, bidet and bedpan sinks are connected to soil stack and all other plumbing fixtures such as baths, sinks, and basins are connected to waste stack through deep seal trap. In addition, a common vent stack is provided for ventilation of soil and waste stacks.
 - 2) **Two pipe system with independent vent pipes** (see Fig. 4B) — The piping system in which all soil appliances such as water closets, urinals, bidet and bedpan sinks are connected to soil stack, and all other plumbing fixtures such as baths, sinks, and basins are connected to waste stack through deep seal trap. In addition, there are independent vent stacks provided for respective ventilation of soil and waste stacks.

2.70 Plumbing

- a) The pipes, fixtures and other apparatus inside a building for bringing in the water supply and removing the liquid and water borne wastes.
- b) The installation of the foregoing pipes, fixtures and other apparatus.

2.71 Plumbing System — The plumbing system shall include the water supply and distribution pipes; plumbing fittings and traps; soil, waste, vent pipes and anti-siphonage pipes; building drains and building sewers including their respective connections, devices and appurtenances within the property lines of the premises; and water-treating or water-using equipment.

2.72 Premises — Premises shall include passages, buildings and lands of any tenure, whether open or enclosed, whether built on or not, and whether public or private in respect of which a water rate or charge is payable to the Authority or for which an application is made for supply of water and disposal of waste to the public sewer.

2.73 Puff Ventilation — The ventilation provided for waste traps in two-pipe system, in order to preserve the water seal.

2.74 Saddle — A purpose made fitting, so shaped as to fit over a hole cut in a sewer or drain used to form connections.

2.75 Sanitary Appliances — The appliances for the collection and discharge of soil or waste matter.

2.76 Sewer — A pipe or conduit, generally closed, but normally not flowing full for carrying sewage and/or other waste liquids.

2.77 Slop Hopper (Slop Sink) — A hopper shaped sink, with a flushing run and outlet similar to those of a WC pan, for the reception and discharge of human excreta.

2.78 Soakaway — A pit, dug into permeable ground lined to form a covered perforated chamber or filled with hard-core, to which liquid is led, and from which it may soak away into the ground.

2.79 Soffit (Crown) — The highest point of the internal surface of a sewer or culvert at any cross-section.

2.80 Soil Appliances — A sanitary appliance for the collection and discharge of excretory matter.

2.81 Soil Pipe — A pipe that conveys the discharge of water closets or fixtures having similar functions, with or without the discharges from other fixtures.

2.82 Soil Waste — The discharge from water closets, urinals, slop hopper, stable yard or cowshed gullies and similar appliances.

2.83 Stack Vent — The extension of a soil or waste stack above the highest horizontal drain connected to the stack.

2.84 Sub Soil Water — Water occurring naturally in the subsoil.

2.85 Sub Soil Water Drain

- a) A drain intended to collect and carry away subsoil water.
- b) A drain intended to disperse into the subsoil from a septic tank.

2.86 Sullage — See 2.99.

2.87 Supply Pipe — So much of any service pipe as is not a communication pipe.

2.88 Supports — Hangers and anchors or devices for supporting and securing pipe and fittings to walls, ceilings, floors or structural members.

2.89 Surface Water — Natural water from the ground surface, paved areas and roofs.

2.90 Surface Water Drain — A drain conveying surface water including storm water.

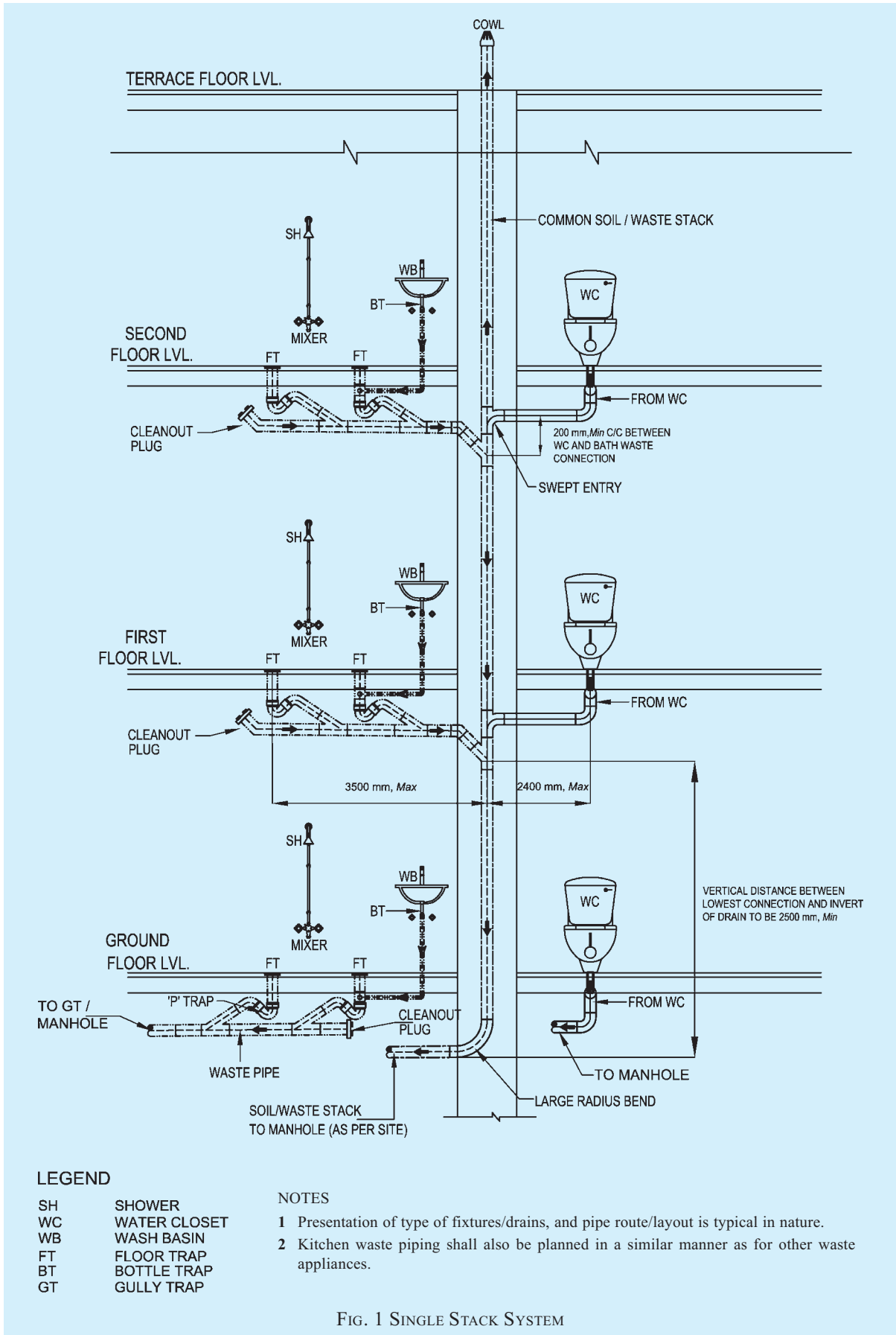

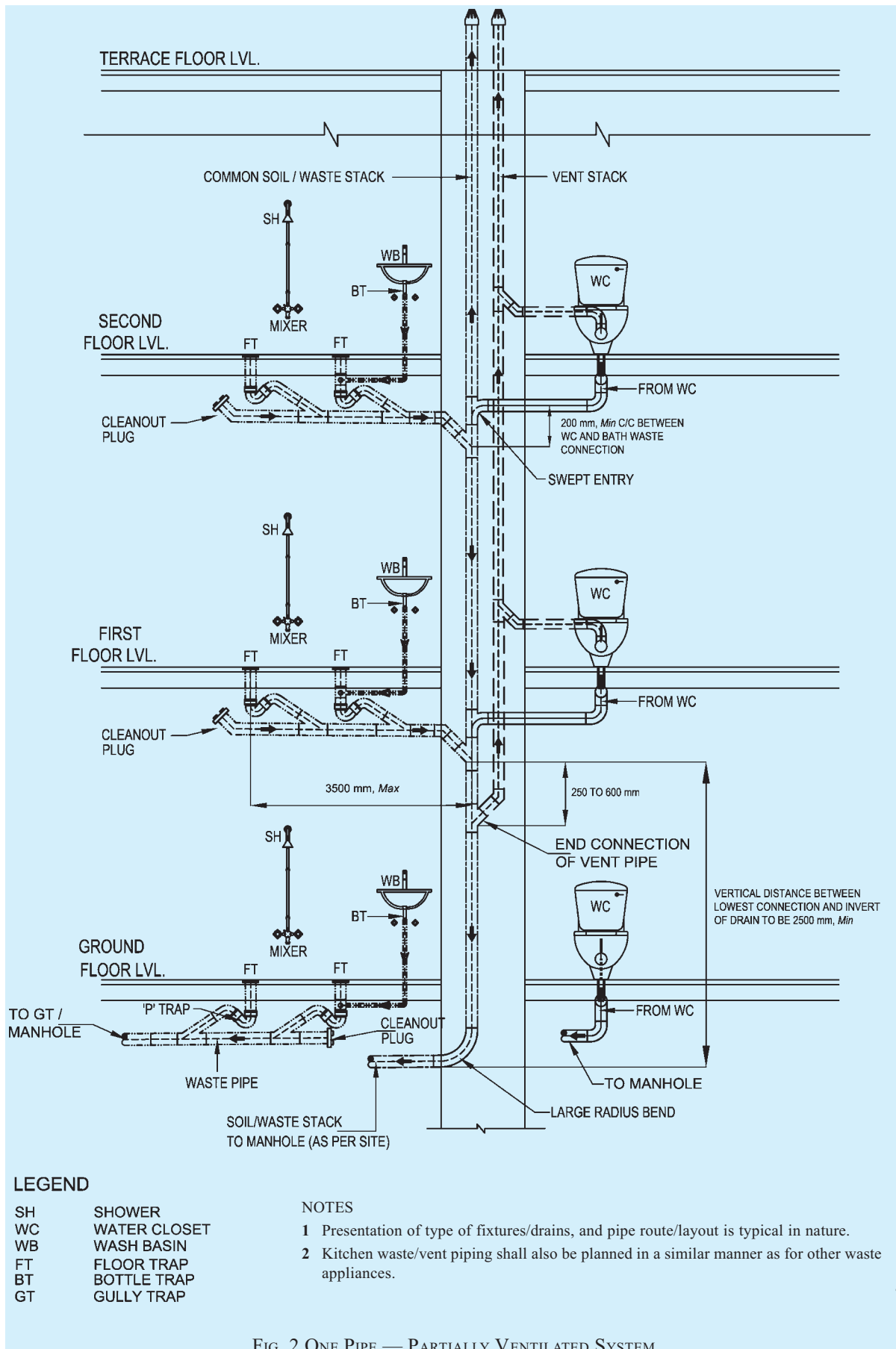
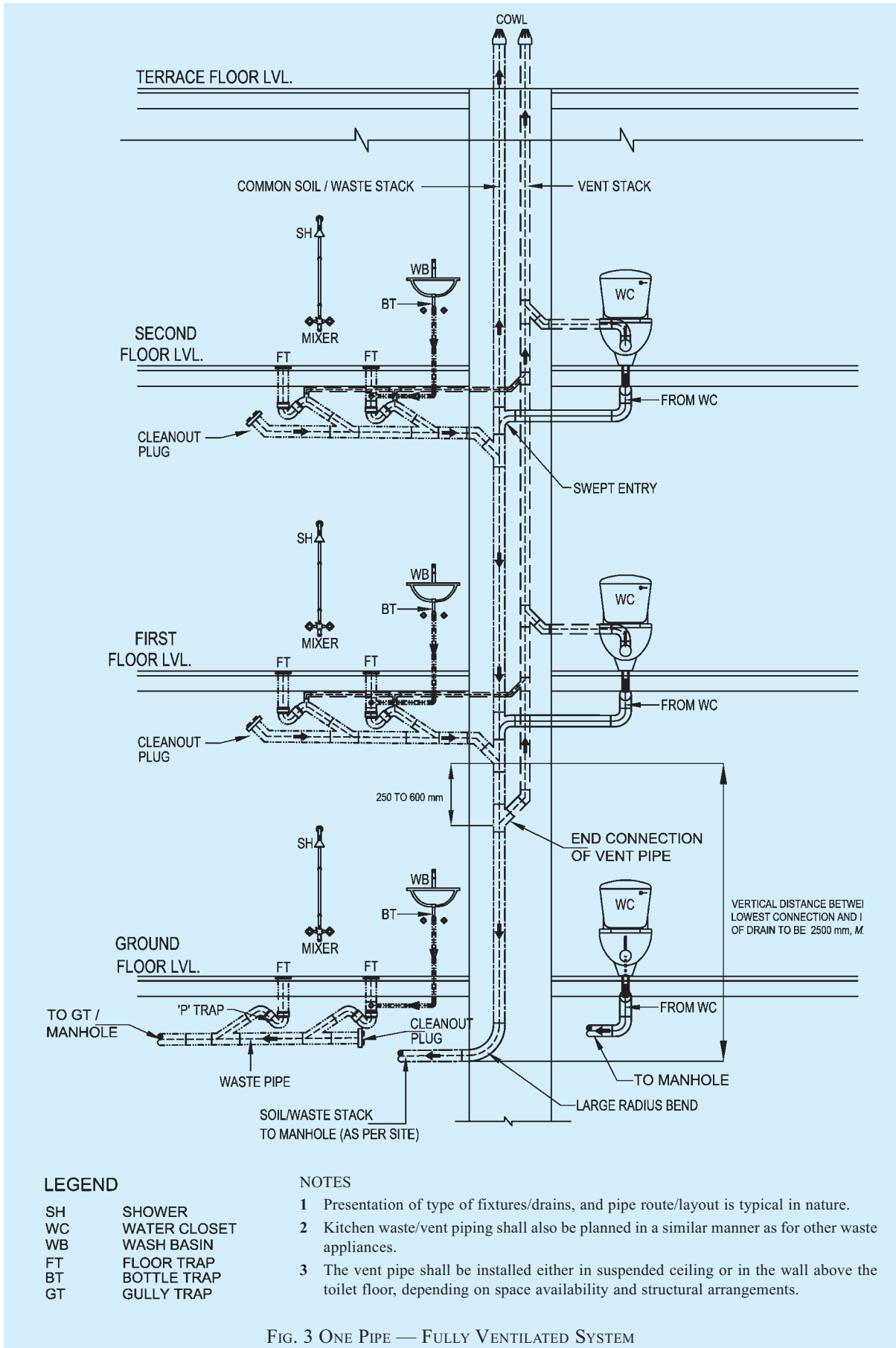
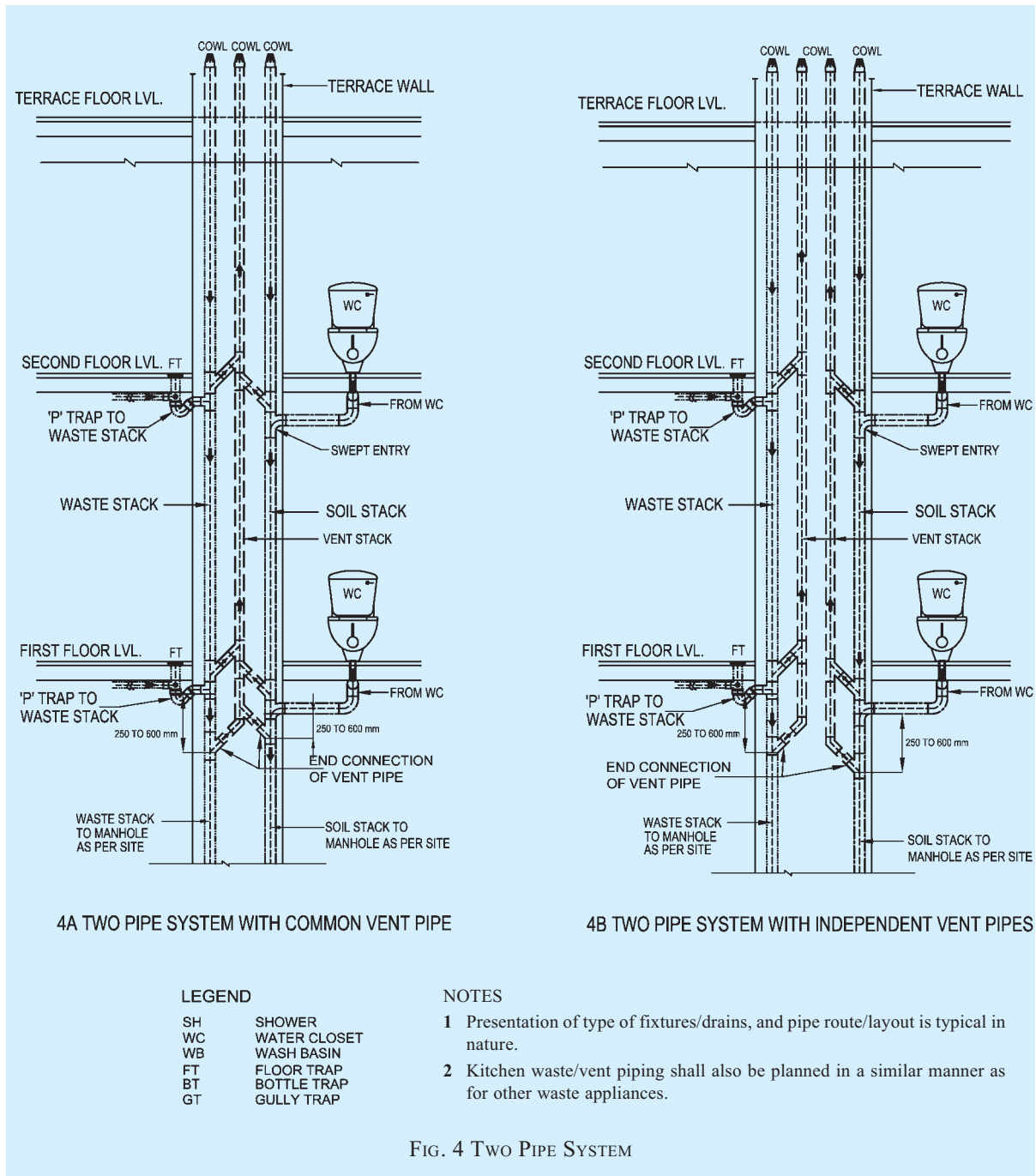

FIG. 2 ONE PIPE — PARTIALLY VENTILATED SYSTEM





2.91 Systems of Drainage

- a) *Combined system* — A system in which foul water (sewage) (black and grey water) and surface water are conveyed by the same sewers and drains.
- b) *Separate system* — A system in which foul water (sewage) (black and grey water) and surface water are conveyed by the separate sewers and drains.
- c) *Partially separate system* — A modification

of the separate system in which part of the surface water is conveyed by the foul (sanitary) sewers and drains.

2.92 Trade Effluent — Any liquid either with or without particles of matter in suspension which is wholly or in part produced in the course of any trade or industry, at trade premise. It includes farm wastes but does not include domestic sewage.

2.93 Trap — A fittings or device so designed and constructed as to provide, when properly vented, a

liquid seal which will prevent the back passage of air without materially affecting the flow of sewage or waste water through it.

2.94 Vertical Pipe — Any pipe or fitting which is installed in a vertical position or which makes an angle or not more than 45° with the vertical.

2.95 Vent Stack/Vent Pipe — A vertical vent-pipe installed primarily for the purpose of proving circulation of air to and from any part of the drainage system. It also protects trap seals from excessive pressure fluctuation.

2.96 Vent System — A pipe or pipes installed to provide a flow of air to or from a drainage system or to provide a circulation of air with in such system to protect traps seals from siphonage and back-pressure.

2.97 Waste Appliance — A sanitary appliance for the collection and discharge of water after use for ablutionary, culinary and other domestic purpose.

2.98 Waste Pipe — In plumbing, any pipe that receives the discharge of any fixtures, except water closets or similar fixtures and conveys the same to the house drain or soil or waste stack. When such pipe does not connect directly with a house drain or soil stack, it is called an indirect waste pipe.

2.99 Waste Water (Sullage) — The discharge from wash basins, sinks and similar appliances, which does not contain human or animal excreta.

2.100 Water Closet — A water flushed plumbing fixture designed to receive human excrement directly from the user of the fixture. The term is used sometimes to designate the room or compartment in which the fixture is placed.

2.101 Water Seal — The water in a trap, which acts as a barrier to the passage of air through the trap.

3 GENERAL

3.1 Basic Principles

The basic principles of water supply, drainage and sanitation are given below, and the design of drainage and sanitation should in general be guided by the applicable principles.

3.1.1 Potable Water

All premises intended for human habitation, occupancy, or use shall be provided with supply of potable water. This water supply shall not be connected with unsafe water resources, nor shall it be subject to the hazards of backflow.

3.1.2 Water Provision

Plumbing fixtures, devices and appurtenances shall be

provided with water in sufficient volume and at pressures adequate to enable them to function properly and without undue noise under normal conditions of use.

There should be at least a residual head of 0.018 N/mm² at the consumer's tap. There may be certain fixtures or appliances in the installation that may require a higher pressure, such as 0.05 N/mm² or even higher (such as 0.1 N/mm² in case of flush valves), in which case the system shall be designed using pumps, tanks or both to achieve the required minimum pressure.

NOTE — The residual head shall be taken at the highest/farthest outlets in the building.

3.1.3 Water Efficiency

Plumbing system shall be designed, installed and adjusted to use the optimum quantity of water consistent with proper performance and cleaning.

3.1.4 Safety Devices

Plumbing system shall be designed and installed with safety devices to safeguard against dangers from contamination, explosion, overheating, etc.

3.1.5 Minimum Amenities

Each dwelling unit on premises (abutting on a sewer or with a private sewage disposal system) shall have at least one water closet, one kitchen wash place or a sink, and one bathing place or shower to meet the basic requirements of sanitation and personal hygiene.

In case of a group housing, the requirements relating to toilet or sanitary room and kitchen as given in **13** and **B-9** of Part 3 'Development Control Rules and General Building Requirements' of the Code shall also be complied with.

3.1.6 Drainage System

The drainage system shall be designed, installed and maintained to guard against fouling, deposit of solids and clogging and with adequate cleanouts so arranged that the pipes may be readily cleaned.

3.1.7 Materials and Workmanship

The plumbing system shall have durable material, free from defective workmanship and so designed and installed as to give satisfactory service for its reasonable expected life. The accessories of the plumbing system should be of such specifications as to meet the functional requirements of the installation, so as to also avoid any inconsistency leading to leakage and resultant seepage.

3.1.8 Fixture Traps and Vent Pipes

Each fixture directly connected to the drainage system shall be equipped with a liquid seal trap. Trap seals shall be maintained to prevent sewer gas, other

potentially dangerous or noxious fumes, or vermin from entering the building. Further, the drainage system shall be designed to provide an adequate circulation of air in all pipes with no danger of siphonage, aspiration, or forcing of trap seals under conditions of ordinary use by providing vent pipes throughout the system.

3.1.9 Foul Air Exhaust

Each vent terminal shall extend to the outer air and be so installed as to minimize the possibilities of clogging and the return of foul air to the building, as it conveys potentially noxious or explosive gases to the outside atmosphere. All vent pipes shall be provided with a cowl.

3.1.10 Testing

The plumbing system shall be subjected to required tests to effectively disclose all leaks and defects in the work or the material.

3.1.11 Exclusion from Plumbing System

No substance that will clog or accentuate clogging of pipes, produce explosive mixtures, destroy the pipes or their joints, or interfere unduly with the sewage-disposal process shall be allowed to enter the drainage system.

3.1.12 Light and Ventilation

Wherever water closet or similar fixture is located in a room or compartment, it should be properly lighted and ventilated.

3.1.13 Individual Sewage Disposal Systems

If water closets or other plumbing fixtures are installed in buildings where connection to public sewer is not possible, suitable provision shall be made for acceptable treatment and disposal.

3.1.14 Maintenance

Plumbing systems shall be maintained in a safe and serviceable condition.

3.1.15 Approach for Use and Cleaning

All plumbing fixtures shall be so installed with regard to spacing as to be approachable for their intended use and for cleaning. All doors, windows and any other device needing access within the toilet shall be so located that they have proper approach.

3.1.16 Accessibility for Persons with Disabilities

All doors, windows and fixtures, including WC, urinals, grab bars, wash basin, mirror and all other accessories for use by persons with disabilities shall be so installed/ located that they have proper access with appropriate width, height, space, centerlines, and ease of operation

(see 13 of Part 3 'Development Control Rules and General Building Requirements' of the Code).

3.1.17 Structural Safety

Plumbing system shall be installed with due regard to preservation of the structural members and prevention of damage to walls and other surfaces.

3.1.18 Protection of Ground and Surface Water

Sewage or other waste shall not be discharged into surface or sub-surface water without acceptable form of treatment.

3.2 Drainage and Sanitation

3.2.1 Preparation and Submission of Plan

No person shall install or carry out any water-borne sanitary installation or drainage installation or any works in connection with anything existing or new buildings or any other premises without obtaining the prior sanction of the Authority.

The owner shall make an application in the prescribed form (see Annex A) to the Authority to carry out such a work.

3.2.2 Site Plan

A site plan of the premises on which the building is to be situated or any such work is to be carried out shall be prepared drawn to a scale not smaller than 1 in 500 (see Part 2 'Administration' of the Code). The site plan of the building premises shall show,

- a) the adjoining plots and streets with their names;
- b) the position of the municipal sewer and the direction of flow in it;
- c) the invert level of the municipal sewer, the road level, and the connection level of the proposed drain connecting the building in relation to the sewer,
- d) the angle at which the drain from the building joints the sewer; and
- e) the alignment, sizes and gradients of all drains and also of surface drains, if any.

A separate site plan is not necessary if the necessary particulars to be shown in such a site plan are already shown in the drainage plan.

3.2.3 Drainage Plan

The application (see 3.3.1) shall be accompanied by a drainage plan drawn to a scale of not smaller than 1 in 100 and furnished along with the building plan (see Part 2 'Administration' of the Code). The plans shall show the following:

- a) Every floor of the building in which the pipes or drains are to be used;
- b) The position, forms, level and arrangement of the various parts of such building, including the roof thereof;
- c) All new drains as proposed with their sizes and gradients;
- d) Invert levels of the proposed drains with corresponding ground levels;
- e) The position of every manhole, gully, soil and waste pipe, vent pipe, rainwater pipe, water closet, urinal, latrine, bath, lavatory, sink, trap or other appliances in the premises proposed to be connected to any drain and the following colours are recommended for indicating sewers, waste water pipes, rainwater pipes an existing work:

<i>Description of Work</i>	<i>Colour</i>
Sewers	Red
Waste water pipes and rainwater pipes	Blue
Existing work	Black

- f) The position of refuse chute, inlet hopper and collection chamber.

3.2.3.1 In the case of an alteration or addition to an existing building, this clause shall be deemed to be satisfied if the plans as furnished convey sufficient information for the proposals to be readily identified with previous sanctioned plans and provided the locations of tanks and other fittings are consistent with the structural safety of the building.

3.2.3.2 The plans for the building drainage shall in every case be accompanied by specifications for the various items of work involved. This information shall be supplied in the prescribed form given in Annex B.

3.2.4 In respect of open drains, cross-sectional details shall be prepared to a scale not smaller than 1 in 50 showing the ground and invert levels and any arrangement already existing or proposed for the inclusion of any or exclusion of all storm water from the sewers.

3.2.5 Completion Certificate

At the completion of the plumbing installation work, the licensed/registered plumber shall give a completion certificate in the prescribed form, which is given in Annex C.

3.3 Licensing/Registration of Plumbers

3.3.1 Execution of Work

The work which is required to be carried out under the provisions of this section, shall be executed only by a licensed/registered plumber under the control of the Authority and shall be responsible to carry out all lawful directions given by the Authority. No individual shall engage in the business of plumbing unless so licensed/registered under the provisions of this Section.

3.3.1.1 No individual, firm, partnership or corporation shall engage in the business of installing, repairing or altering plumbing unless the plumbing work performed in the course of such business is under the direct supervision of a licensed/registered plumber from approved Authority.

3.3.2 Examination and Certification

The Authority shall establish standards and procedure for the qualification, examination and licensing/registration of plumbers and shall issue licences to such persons who meet the qualifications thereof and successfully pass the examination.

3.3.3 For guidelines for registration of plumbers including the minimum standards for qualifications for the grant of licences, reference may be made to good practice [9-2(2)]. The Authority may also utilize the services of the certified plumbers who are certified for the required skill level under the appropriate scheme of the Government.

4 DRAINAGE AND SANITATION

4.1 Types of Sanitary Appliances

4.1.1 Soil Appliances

4.1.1.1 Water closet

It shall essentially consist of a closet consisting of a bowl to receive excretory matter, trap and a flushing apparatus. It is recommended to provide ablation trap adjacent to the water closet, preferably on right hand side wall. The various types/style of water closets may be:

- a) Squatting Indian type water closet,
- b) Washdown type water closet,
- c) Siphonic washdown type water closet, and
- d) Universal or Anglo-Indian water closet.

4.1.1.2 Bidet

Bidet is an ablation appliance for cleansing excretory organs with water for personnel hygiene. It may be pedestal type or wall hung with a shallow bowl. Hot and cold water supplied through a mixer is discharged from a spray installed over the rim of the appliance. The bidet outlet should essentially connect to soil pipe in a system.

4.1.1.3 Urinal

It is a soil appliance for urination and is connected to soil pipe after a suitable trap. Urinal should have adequate provision of flushing apparatus. The various types/style of urinal may be:

- a) Bowl type urinal: flat back or angle back.
- b) Slab (single) type urinal.
- c) Stall (single) type urinal.
- d) Squatting plate type urinal.
- e) Syphon jet urinal with integral trap.
- f) Water less (non-water) urinal

4.1.1.4 Slop sink

Slop sink is a large sink, generally of square shape. the appliance is used in hospitals and is installed in the dirty utility room, sluice room and similar locations for disposal of excreta and other foul waste and for washing bed pans and urine bottles/pans. It is provided with a flushing mechanism. It is also provided in Janitor's closet where it is used for cleaning the housekeeping mops, etc.

4.1.1.5 Bed pan sink

Bed pan sink, also known as bedpan washer and disinfectant, is a part of medical equipment inventory which is used to clean manually or automatically, the hospital bedpans, urine bottles and other containers used for collecting body fluids. It is provided in dirty utility room, sluice room, similar locations for disposal of excreta and other foul waste and for washing bed pans, urine bottles/pans. It is a soil appliance and is connected to soil pipe after a suitable trap. In manual models, it has a flushing arrangement.

Provision for installing a bedpan washer and disinfectant should be made in all intensive care units in hospitals.

4.1.2 Waste Appliances

4.1.2.1 Wash basin

It is of one-piece construction having a combined overflow and preferably should have soap holding recess or recesses that should properly drain into the bowl. Each basin shall have circular waste hole through which the liquid content of the basin shall drain.

4.1.2.2 Wash-trough

It is a linear trough for simultaneous use by number of persons.

4.1.2.3 Sink

It is used in kitchen and laboratory for the purpose of cleaning utensils/ apparatus and also serve the purpose of providing water for general usage. The sink may be made with or without overflow arrangement. The sink shall be of one-piece construction including combined over flow, where provided. The sink shall have a circular waste hole into which the interiors of the sink shall drain.

4.1.2.4 Bath tub

Bath tub may be of enameled steel, cast iron, gel-coated, glass fibre reinforced plastic or may be cast *in-situ*. It shall be stable, comfortable, easy to get in and out, water tight, with anti-skid base, and easy to install and maintain. The bath tub shall be fitted with overflow and waste pipe of nominal diameter of not less than 32 mm and 40 mm, respectively.

4.1.2.5 Drinking fountain

It is a bowl fitted with a push button tap and a water bubbler or a tap with a swan neck outlet fitting. It has a waste fitting, a trap and is connected to the waste pipe.

4.1.3 The requirements of various soil appliances and waste appliances shall be in accordance with accepted standards [9-2(3)].

4.2 Drainage and Sanitation Requirements

4.2.1 General

There should be at least one water tap and arrangement for drainage in the vicinity of each water closet or group of water closet in all the buildings.

4.2.2 Each dwelling unit on premises (abutting on a sewer or with a private sewage disposal system) shall have at least one water closet, one kitchen wash place or a sink, and one bathing place or shower to meet the basic requirements of sanitation and personal hygiene.

In case of a group housing, the requirements relating to toilet or sanitary room and kitchen as given in **13** and **B-9** of Part 3 'Development Control Rules and General Building Requirements' of the Code shall also be complied with.

4.2.3 All other structures for human occupancy or use on premises (abutting on a sewer or with a private sewage disposal system) shall have adequate sanitary facilities, but in no case less than one water closet and one other fixture for cleaning purposes.

Table 1 Office Building
(Clause 4.2.5.1)

SI No.	Fixtures	Public Toilets		Staff Toilets	
		Males	Females	Males	Females
(1)	(2)	(3)	(4)	(5)	(6)
Executive Rooms and Conference Halls in Office Buildings					
i)	Toilet suite comprising one WC, one wash basin (with optional shower stall if building is used round the clock at user's option) Pantry optional as per user requirement	Unit could be common for male/female or separate depending on the number of user of each facility		For individual officer rooms	
Main Office Toilets for Staff and Visitors					
ii)	Water closets	See Note		1 per 25	1 per 15
iii)	Ablution tap with each water closet	← 1 in each water closet →			
iv)	Urinals	See Note	—	Nil up to 6 1 for 7 to 20 2 for 21 to 45 3 for 46 to 70 4 for 71 to 100 From 101 to 200, add @ 3% For over 200, add @ 2.5%	—
v)	Wash basins	See Note		1 per 25	1 per 25
vi)	Drinking water fountain	See Note		1 per 100	1 per 100
vii)	Cleaner's sink	← 1 per floor →			
NOTE — Staff and public toilet utilities are generally common in office buildings. Where public toilets are to be provided independently, similar requirements as that of staff toilet may be provided.					

4.2.4 For Residences

4.2.4.1 Dwelling with individual convenience shall have at least the following fitments:

- a) One bath room provided with a tap and a floor trap;
- b) One water closet with flushing apparatus with an ablution tap; and
- c) One tap with a floor trap or a sink in kitchen or wash place.

4.2.4.1.1 Where only one water closet is provided in a dwelling, it is desirable to have the bath and water closet separately accommodated.

4.2.4.2 Dwellings without individual conveniences shall have the following fitments:

- a) One water tap with floor trap in each tenement,
- b) One water closet with flushing apparatus and one ablution tap bath for every two tenements, and
- c) One bath with water tap and floor trap for every two tenements.

4.2.5 For Buildings Other than Residences

4.2.5.1 The requirements for fitments for drainage and sanitation in the case of buildings other than residences shall be in accordance with Table 1 to Table 15.

The accessibility requirements for provision of these facilities for persons with disabilities shall be in accordance with 13 of Part 3 'Development Control Rules and General Building Requirements' of the Code.

The following shall be, in addition, taken into consideration:

- a) The figures shown are based upon one (1) fixture being the minimum required for the number of persons indicated or part thereof.
- b) Building categories not included in the tables shall be considered separately by the Authority.
- c) Drinking fountains shall not be installed in the toilets.
- d) Where there is the danger of exposure to skin contamination with poisonous, infectious or irritating material, wash basin with eye wash jet and an emergency shower (safety shower with eye wash unit) located in an area accessible at all times with the passage/right of way suitable for access to a wheel chair, shall be provided.
- e) When applying the provision of these tables for providing the number of fixtures, consideration shall be given to the accessibility of the fixtures. Using purely numerical basis may not result in an

Table 2 Factories
(Clause 4.2.5.1)

Sl No.	Fixtures	Offices/Visitors		Workers	
		Males	Females	Males	Females
(1)	(2)	(3)	(4)	(5)	(6)
i)	Water closets (workers and staff)	1 for up to 25 2 for 26 to 35 3 for 36 to 65 4 for 66 to 100	1 for up to 15 2 for 16 to 25 3 for 26 to 40 4 for 41 to 57 5 for 58 to 77 6 for 78 to 100	1 for up to 15 2 for 16 to 35 3 for 36 to 65 4 for 66 to 100	1 for up to 12 2 for 13 to 25 3 for 26 to 40 4 for 41 to 57 5 for 58 to 77 6 for 78 to 100
	For persons 101-200 add	3%	5%	3%	5%
	For persons over 200 add	2.5%	4%	2.50%	4%
ii)	Ablution tap	1 in each water closet	1 in each water closet	1 in each water closet	1 in each water closet
iii)	Urinals	Nil up to 6 1 for 7 to 20 2 for 21 to 45 3 for 46 to 70 4 for 71 to 100 From 101 to 200, add @ 3% For over 200, add @ 2.5%	—	Nil up to 6 1 for 7 to 20 2 for 21 to 45 3 for 46 to 70 4 for 71 to 100 From 101 to 200, add @ 3% For over 200, add @ 2.5%	—
iv)	Wash basins	1 per 25 or part thereof	1 per 25 or part thereof	1 per 25 or part thereof	1 per 25 or part thereof
	Wash basins in rows or troughs and taps spaced 750 mm c/c				
v)	Drinking water fountain	1 per every 100 or part thereof with minimum one on each floor	1 per every 100 or part thereof with minimum one on each floor	1 per every 100 or part thereof with minimum one on each floor	1 per every 100 or part thereof with minimum one on each floor
vi)	Cleaner's sink	1 on each floor	1 on each floor	1 on each floor	1 on each floor
vii)	Showers/bathing rooms	As per trade requirements			
viii)	Emergency shower and eye wash fountain	—	—	1 per every shop floor	per 500 persons

NOTES

1 For factories requiring workers to be engaged in dirty and dangerous operations or requiring them to be extremely clean and sanitized conditions additional and separate (if required so) toilet facilities and if required by applicable Industrial and safety laws and the *Factories Act* shall be provided in consultation with the user.

2 Depending on the type of disability of a person and the hazard posed by the type of activities in the factory for a person with disabilities, if a person with disabilities is decided to be engaged for a particular activity, the requirements of accessibility shall be guided by the provisions given in 13 of Part 3 'Development Control Rules and General Building Requirements' of the Code.

Table 3 Cinema, Multiplex Cinema, Concert and Convention Halls, Theatres and Stadia
(Clause 4.2.5.1)

Sl No.	Fixtures	Public		Staff	
		Males	Females	Males	Females
(1)	(2)	(3)	(4)	(5)	(6)
i)	Water closets	1 per 100 up to 400 Over 400 add at 1 per 250 or part thereof	3 per 100 up to 200 Over 200 add at 2 per 100 or part thereof	1 for up to 15 2 for 16 to 35	1 for up to 12 2 for 13 to 25
ii)	Ablution tap	1 in each water closet	1 in each water closet	1 in each water closet	1 in each water closet
		1 water tap with draining arrangements shall be provided for every 50 persons or part thereof in the vicinity of water closets and urinals			
iii)	Urinals	1 per 25 or part thereof	—	Nil up to 6 1 for 7 to 20 2 for 21 to 45	—
iv)	Wash basins	1 per 200 or part thereof		1 for up to 15 2 for 16 to 35	1 for up to 12 2 for 13 to 25
v)	Drinking water fountain	1 per 100 persons or part thereof			
vi)	Cleaner's sink	1 per floor			
vii)	Showers/bathing rooms	As per trade requirements			

NOTES

1 Some WCs may be Indian style, if desired.

2 Male population may be assumed as two-third and female population as one-third.

Table 4 Art Galleries, Libraries and Museums
(Clause 4.2.5.1)

SI No.	Fixtures	Public		Staff	
		Males	Females	Males	Females
(1)	(2)	(3)	(4)	(5)	(6)
i)	Water closets	1 per 200 up to 400 Over 400 add at 1 per 250 or part thereof	1 per 100 up to 200 Over 200 add at 1 per 150 or part thereof	1 for up to 15 2 for 16 to 35	1 for up to 12 2 for 13 to 25
ii)	Ablution tap	One in each water closet	One in each water closet	One in each water closet	One in each water closet
1 water tap with draining arrangements shall be provided for every 50 persons or part thereof in the vicinity of water closets and urinals					
iii)	Urinals	1 per 50	—	Nil up to 6 1 per 7 to 20 2 per 21 to 45	—
iv)	Wash basins	1 for every 200 or part thereof. For over 400, add at 1 per 250 persons or part thereof	1 for every 200 or part thereof. For over 200, add at 1 per 150 persons or part thereof	1 for up to 15 2 for 16 to 35	1 for up to 12 2 for 13 to 25
v)	Drinking water fountain	←————— 1 per 100 persons or part thereof —————→			
vi)	Cleaner's sink	←————— 1 per floor (Minimum) —————→			
vii)	Showers/bathing rooms	←————— As per requirements —————→			

NOTES
1 Some WCs may be Indian style, if desired.
2 Male population may be assumed as two-third and female population as one-third.

Table 5 Hospitals with Indoor Patient Wards
(Clause 4.2.5.1)

SI No.	Fixtures	Patient Toilets		Staff Toilets	
		Males	Females	Males	Females
(1)	(2)	(3)	(4)	(5)	(6)
i)	Toilet suite comprising one WC and one wash basin and shower stall	Private room with up to 4 patients		For individual doctor's/officer's rooms	
For General Wards, Hospital Staff and Visitors					
ii)	Water closets	1 per 5 beds or part thereof	1 per 5 beds or part thereof	1 for up to 15 2 for 16 to 35	1 for up to 12 2 for 13 to 25
iii)	Ablution tap	One in each water closet	One in each water closet	One in each water closet	One in each water closet
1 water tap with draining arrangements shall be provided for every 50 persons or part thereof in the vicinity of water closets and urinals					
iv)	Urinals	1 per 15 beds	—	Nil up to 6 1 for 7 to 20 2 for 21 to 45	—
v)	Wash basins	2 for every 30 beds or part thereof. Add 1 per additional 30 beds or part thereof		1 for up to 15 2 for 16 to 35	1 for up to 12 2 for 13 to 25
vi)	Drinking water fountain	1 per ward		1 per 100 persons or part thereof	
vii)	Cleaner's sink	1 per ward		—	
viii)	Bed pan sink	1 per ward		—	
ix)	Kitchen sink	1 per ward		—	

NOTES
1 Some WCs may be of Indian style, if desired.
2 Male population may be assumed as two-third and female population as one-third.
3 Provision for additional and special hospital fittings where required shall be made.
4 Drinking water fountains are not recommended for hospitals for reasons of infection control. This is to be decided by the health authority recommendations.

Table 6 Hospitals with Outdoor Patient Department
(Clause 4.2.5.1)

SI No.	Fixtures	Patient Toilets		Staff Toilets	
		Males (3)	Females (4)	Males (5)	Females (6)
i)	Toilet suite comprising one WC and one wash basin (with optional shower stall if building used for 24 h)	For up to 4 patients		For individual doctor's/officer's rooms	
ii)	Water closets	1 per 100 persons or part thereof	2 per 100 persons or part thereof	1 for up to 15 2 for 16 to 35	1 for up to 12 2 for 13 to 25
iii)	Ablution tap	One in each water closet	One in each water closet	One in each water closet	One in each water closet
		1 water tap with draining arrangements shall be provided for every 50 persons or part thereof in the vicinity of water closets and urinals			
iv)	Urinals	1 per 50 persons or part thereof	—	Nil up to 6 1 for 7 to 20 2 for 21 to 45	—
v)	Wash basins	2 per 100 persons of part thereof	2 per 100 persons or part thereof	1 for up to 15 2 for 16 to 35	1 for up to 12 2 for 13 to 25
vi)	Drinking water fountain	See Note 2		1 per 100 persons or part thereof	

NOTES

- Some WCs may be Indian style, if desired.
- Drinking water fountains are not recommended for hospitals for reasons of infection control. This to be decided by the health authority recommendation.
- The WCs shall be provided keeping in view the location of main OPD waiting hall and sub-waiting halls, floor wise, so as to serve the people effectively. The number of patients shall be calculated floor wise. The OPD population shall include patient attendants @ at least 1 per patient.
- Male population may be assumed as two-third and female population as one-third.
- Provision for additional and special hospital fittings where required shall be made.

Table 7 Hospitals, Administrative Buildings
(Clause 4.2.5.1)

SI No.	Fixtures	Staff Toilets	
		Males (3)	Females (4)
i)	Toilet suite comprising one WC, one urinal and one wash basin (with optional shower stall if building used for 24 h)	For individual doctor's/officer's rooms	
ii)	Water closets	1 per 25 persons or part thereof	1 per 15 persons or part thereof
iii)	Ablution tap	One in each water closet	One in each water closet
		1 water tap with draining arrangements shall be provided for every 50 persons or part thereof in the vicinity of water closets and urinals	
iv)	Urinals	1 for 6 to 15 2 for 16 to 50	—
v)	Wash basins	1 per 25 persons or part thereof	1 per 25 persons or part thereof
vi)	Drinking water fountain	1 per 100 persons or part thereof (See Note 2)	
vii)	Cleaner's sink	1 per floor, <i>Min</i>	
viii)	Kitchen sink	1 per floor, <i>Min</i>	

NOTES

- Some WCs may be Indian style, if desired.
- Drinking water fountains to be provided only when it is a separate block and patients will not use it.

Table 8 Hospitals Staff Quarters and Nurses Homes
(Clause 4.2.5.1)

Sl No.	Fixtures	Staff Quarters		Nurses Homes	
		Males (3)	Females (4)	Males (5)	Females (6)
i)	Water closets	1 per 4 persons or part thereof	1 per 4 persons or part thereof	1 per 4 persons or part thereof 2 for 5 to 35	1 per 4 persons or part thereof 2 for 5 to 25
ii)	Ablution tap	One in each water closet 1 water tap with draining arrangements shall be provided for every 50 persons or part thereof in the vicinity of water closets and urinals	One in each water closet	One in each water closet	One in each water closet
iii)	Wash basins	1 per 8 persons or part thereof		1 per 8 persons or part thereof	
iv)	Bath (showers)	1 per 4 persons or part thereof		1 per 4 to 6 persons or part thereof	
v)	Drinking water fountain	1 per 100 persons or part thereof, <i>Min</i> 1 per floor		1 per 100 persons or part thereof, <i>Min</i> 1 per floor	
vi)	Cleaner's sink	1 per Floor		1 per Floor	

NOTES
1 Some WCs may be Indian style, if desired.
2 For independent housing units, fixtures shall be provided as for residences.

Table 9 Hotels
(Clause 4.2.5.1)

Sl No.	Fixtures	Public Rooms		Non Residential Staff	
		Males (3)	Females (4)	Males (5)	Females (6)
i)	Toilet suite comprising one WC, wash basin with shower or a bath tub	Individual guest rooms with attached toilets		—	
Guest Rooms with Common Facilities					
ii)	Water closets	1 per 100 persons up to 400 Over 400 add at 1 per 250 or part thereof	2 per 100 persons up to 200 Over 200 add at 1 per 100 or part thereof	1 for up to 15 2 for 16 to 35 3 for 36 to 65 4 for 66 to 100	1 for up to 12 2 for 13 to 25 3 for 26 to 40 4 for 41 to 57 5 for 58 to 77 6 for 78 to 100
iii)	Ablution tap	One in each water closet 1 water tap with draining arrangements shall be provided for every 50 persons or part thereof in the vicinity of water closets and urinals	One in each water closet	One in each water closet	One in each water closet
iv)	Urinals	1 per 50 persons or part thereof	—	Nil up to 6 1 for 7 to 20 2 for 21 to 45 3 for 46 to 70 4 for 71 to 100	—
v)	Wash basins	1 per WC/Urinal	1 per WC	1 for up to 15 2 for 16 to 35 3 for 36 to 65 4 for 66 to 100	1 for up to 12 2 for 13 to 25 3 for 26 to 40 4 for 41 to 57
vi)	Bath (showers)	1 per 10 persons or part thereof		—	—
vii)	Cleaner's sink	1 per 30 rooms, <i>Min</i> 1 per floor			
viii)	Kitchen sink	1 per kitchen			

NOTES
1 Some WCs may be Indian style, if desired.
2 Male population may be assumed as two-third and female population as one-third.
3 Provision for additional and special fittings where required shall be made.

Table 10 Restaurants
(Clause 4.2.5.1)

SI No.	Fixtures	Public Rooms		Non-Residential Staff	
		Males	Females	Males	Females
(1)	(2)	(3)	(4)	(5)	(6)
i)	Water closets	1 per 50 seats up to 200 Over 200 add at 1 per 100 or part thereof	2 per 50 seats up to 200 Over 200 add at 1 per 100 or part thereof	1 for up to 15 2 for 16 to 35 3 for 36 to 65 4 for 66 to 100	1 for up to 12 2 for 13 to 25 3 for 26 to 40 4 for 41 to 57 5 for 58 to 77 6 for 78 to 100
ii)	Ablution tap	One in each water closet	One in each water closet	One in each water closet	One in each water closet
		1 water tap with draining arrangements shall be provided for every 50 persons or part thereof in the vicinity of water closets and urinals			
iii)	Urinals	1 per 50 persons or part thereof	—	Nil up to 6 1 for 7 to 20 2 for 21 to 45 3 for 46 to 70 4 for 71 to 100	—
iv)	Wash basins	1 per WC	1 per WC	1 per WC	1 per WC
v)	Cleaner's sink			1 per each restaurant	
vi)	Kitchen sink/dish washer			1 per kitchen	
NOTES					
1 Some WCs may be Indian style, if desired.					
2 Male population may be assumed as two-third and female population as one-third.					
3 Provision for additional and special fittings where required shall be made.					

Table 11 Schools and Educational Institutions
(Clause 4.2.5.1)

SI No.	Fixtures	Nursery School	Non-Residential		Residential	
			Boys	Girls	Boys	Girls
(1)	(2)	(3)	(4)	(5)	(6)	(7)
i)	Water closets	1 per 15 pupils or part thereof	1 per 40 pupils or part thereof	1 per 25 pupils or part thereof	1 per 8 pupils or part thereof	1 per 6 pupils or part thereof
ii)	Ablution tap	One in each water closet	One in each water closet	One in each water closet	One in each water closet	One in each water closet
		1 water tap with draining arrangements shall be provided for every 50 persons or part thereof in the vicinity of water closets and urinals				
iii)	Urinals	—	1 per 20 pupils or part thereof	—	1 per 25 pupils or part thereof	—
iv)	Wash basins	1 per 15 pupils or part thereof	1 per 60 pupils or part thereof	1 per 40 pupils or part thereof	1 per 8 pupils or part thereof	1 per 6 pupils or part thereof
v)	Bath/showers	1 per 40 pupils or part thereof	—	—	1 per 8 pupils or part thereof	1 per 6 pupils or part thereof
vi)	Drinking water fountain or taps	1 per 50 pupils or part thereof	1 per 50 pupils or part thereof	1 per 50 pupils or part thereof	1 per 50 pupils or part thereof	1 per 50 pupils or part thereof
vii)	Cleaner's sink	←—————→			1 per each floor	—————→
NOTES						
1 Some WCs may be Indian style, if desired.						
2 For teaching staff, the schedule of fixtures to be provided shall be the same as in case of office building.						

Table 12 Hostels

(Clause 4.2.5.1)

SI No.	Fixtures	Resident		Non-Resident		Visitor/Common Rooms	
		Males	Females	Males	Females	Males	Females
(1)	(2)	(3)	(4)	(5)	(6)	(7)	(8)
i)	Water closets	1 per 8 or part thereof	1 per 6 or part thereof	1 for up to 15 2 for 16 to 35 3 for 36 to 65 4 for 66 to 100	1 for up to 12 2 for 13 to 25 3 for 26 to 40 4 for 41 to 57 5 for 58 to 77 6 for 78 to 100	1 per 100 up to 400 Over 400 add at 1 per 250	2 per 100 up to 200 Over 200 add at 1 per 100
ii)	Ablution tap	One in each water closet 1 water tap with draining arrangements shall be provided for every 50 persons or part thereof in the vicinity of water closets and urinals	One in each water closet	One in each water closet	One in each water closet	One in each water closet	One in each water closet
iii)	Urinals	1 per 25 or part thereof	—	Nil up to 6 1 for 7 to 20 2 for 21 to 45 3 for 46 to 70 4 for 71 to 100	—	1 per 50 or part thereof	—
iv)	Wash basins	1 per 8 persons or part thereof	1 per 6 persons or part thereof	1 for up to 15 2 for 16 to 35 3 for 36 to 65 4 for 66 to 100	1 for up to 12 2 for 13 to 25 3 for 26 to 40 4 for 41 to 57 5 for 58 to 77 6 for 78 to 100	1 per WC/Urinal	1 per WC
v)	Bath/showers	1 per 8 persons or part thereof	1 per 6 persons or part thereof	—	—	—	—
vi)	Cleaner's sink	←—————		1 per each floor	—————→		

NOTE — Some WCs may be Indian style, if desired.

Table 13 Fruit and Vegetable Markets

(Clause 4.2.5.1)

SI No.	Fixtures	Shop Owners		Common Toilets in Market Building		Public Toilet for Floating Population	
		Males	Females	Males	Females	Males	Females
(1)	(2)	(3)	(4)	(5)	(6)	(7)	(8)
i)	Water closets	1 per 8 or part thereof		1 for up to 15 2 for 16 to 35 3 for 36 to 65 4 for 66 to 100	1 for up to 12 2 for 13 to 25 3 for 26 to 40 4 for 41 to 57 5 for 58 to 77 6 for 78 to 100	1 per 50 (Min 2)	1 per 50 (Min 2)
ii)	Ablution tap	One in each water closet 1 water tap with draining arrangements shall be provided in receiving/ sale area of each shop and for every 50 persons or part thereof in the vicinity of water closets and urinals	One in each water closet	One in each water closet	One in each water closet	One in each water closet	One in each water closet
iii)	Urinals	—	—	Nil up to 6 1 for 7 to 20 2 for 21 to 45 3 for 46 to 70 4 for 71 to 100	—	1 per 50	—
iv)	Wash basins	1 per 8 or part thereof		1 for up to 15 2 for 16 to 35 3 for 36 to 65 4 for 66 to 100	1 for up to 12 2 for 13 to 25 3 for 26 to 40 4 for 41 to 57	—	—
v)	Bath/showers	1 per 8 persons or part thereof	1 per 6 persons or part thereof	—	—	1 per 50 persons	1 per 50 persons

NOTES
 1 Toilet facilities for individual buildings in a market should be taken same as that for office buildings.
 2 Common toilets in the market buildings provide facilities for persons working in shops and their regular visitors.
 3 Special toilet facilities for a large floating population of out of town buyers/sellers, labour, drivers of vehicles for whom special toilet (public toilets).

Table 14 Bus Stations, Airports and Railway Stations

(Clause 4.2.5.1)

Sl No.	Fixtures	Junction Stations, Intermediate Stations and Bus Stations		Terminal Railway and Bus Stations		Domestic and International Airports	
		Males (3)	Females (4)	Males (5)	Females (6)	Males (7)	Females (8)
i)	Water closets	3 for up to 1 000 Add 1 per additional 1 000 or part thereof	4 for up to 1 000 Add 1 per additional 1 000 or part thereof	4 for up to 1 000 Add 1 per additional 1 000 or part thereof	5 for up to 1 000 Add 1 per additional 1 000 or part thereof	Min 2 For 200 : 5 For 400 : 9 For 600 : 12 For 800 : 16 For 1 000 : 18	Min 2 For 200 : 8 For 400 : 15 For 600 : 20 For 800 : 26 For 1 000 : 29
ii)	Ablution tap	One in each water closet	One in each water closet	One in each water closet	One in each water closet	One in each water closet	One in each water closet
1 water tap with draining arrangements shall be provided for every 50 persons or part thereof in the vicinity of water closets and urinals							
iii)	Urinals	4 for up to 1 000 Add 1 per additional 1 000	—	6 for up to 1 000 Add 1 per additional 1 000	—	1 per 40 or part thereof	—
iv)	Wash basins	1 per WC/Urinal	1 per WC	1 per WC/Urinal	1 per WC	1 per WC/Urinal	1 per WC
v)	Bath/showers	2 per 1 000		3 per 1 000		4 per 1 000	
vi)	Drinking water fountain or taps (in common lobby for male/female)	2 per 1 000 or part thereof		3 per 1 000 or part thereof		4 per 1 000 or part thereof	
vii)	Cleaner's sink	1 per toilet compartment with 3 WCs	1 per toilet compartment with 3 WCs	1 per toilet compartment with 3 WCs	1 per toilet compartment with 3 WCs	1 per toilet compartment with 3 WCs	1 per toilet compartment with 3 WCs

NOTES

- Some WCs may be Indian style, if desired.
- Male population may be assumed as three-fifth and female population as two-fifth.
- Separate provision shall be made for staff and workers.

Table 15 Shopping Malls and Retail Buildings

(Clause 4.2.5.1)

Sl No.	Fixtures	Staff Toilets in Shopping Building		Public Toilet for Floating Population	
		Males (5)	Females (6)	Males (7)	Females (8)
i)	Water closets	1 for up to 15 2 for 16 to 35 3 for 36 to 65 4 for 66 to 100	1 for up to 12 2 for 13 to 25 3 for 26 to 40 4 for 41 to 57 5 for 58 to 77 6 for 78 to 100	1 per 50 (Min 2)	1 per 50 (Min 2)
ii)	Ablution tap	One in each water closet	One in each water closet	One in each water closet	One in each water closet
iii)	Urinals	Nil up to 6 1 for 7 to 20 2 for 21 to 45 3 for 46 to 70 4 for 71 to 100	—	1 per 50	—
iv)	Wash basins	1 for up to 15 2 for 16 to 35 3 for 36 to 65 4 for 66 to 100	1 for up to 12 2 for 13 to 25 3 for 26 to 40 4 for 41 to 57	1 per 50 (Min 2)	1 per 50 (Min 2)
v)	Bath/showers	1 per 100 persons	1 per 100 persons	—	—

NOTES

- Toilet facilities for individual facilities in a shopping building should be taken same as that for office buildings.
- Staff toilets in the shopping buildings provide facilities for persons working in shops and building, as well as for maintenance staff.
- The number of persons against the fixture bath/showers represent the maintenance staff requiring such facility.
- Public toilet facilities are provided for a large floating population for buyers and visitors.

installation suited to the need of a specific building. For example, schools should be provided with toilet facilities on each floor. Similarly, toilet facilities shall be provided for temporary workmen employed in any establishment according to the needs; and in any case one WC and one wash basin shall be provided.

- f) All buildings used for human habitation for dwelling, work, occupation, medical care or any purpose detailed in the various tables, abutting a public sewer or a private sewage disposal system, shall be provided with minimum sanitary facilities as per the schedule in the tables. In case the disposal facilities are not available, they shall be provided as a part of the building design for ensuring high standards of sanitary conditions in accordance with this section.
- g) Workplaces where crèches are provided, they shall be provided with one WC for 10 persons or part thereof, one wash basin for 15 persons or part thereof, one kitchen sink with floor trap for preparing food/milk preparations. The sink provided shall be with a drinking water tap.
- h) In all types of buildings, individual toilets and pantry should be provided for executives, and for meeting/seminar/conference rooms, etc, as per the user requirement.
- j) Where food is consumed indoors, water stations may be provided in place of drinking water fountains.

4.3 Materials, Fittings and Appliances

4.3.1 Standards for Materials, Fittings and Sanitary Appliances

All materials, fittings and sanitary appliances shall conform to Part 5 'Building Materials' of the Code.

4.3.2 Choice of Material for Pipes

4.3.2.1 Salt glazed stoneware pipe

For all sewers and drains in all soils, except where supports are required as in made-up ground, glazed stoneware pipe shall be used as far as possible in preference to other types of pipes. These pipes are particularly suitable where acid effluents or acid subsoil conditions are likely to be encountered. Salt glazed stoneware pipes shall conform to accepted standards [9-2(4)].

4.3.2.2 Cement concrete pipes

When properly ventilated, cement concrete pipes with spigot and socket or collar joints present an alternative to glazed stoneware sewers of over 150 mm diameter.

These shall not be used to carry acid effluents or sewage under conditions favourable for the production of hydrogen sulphide and shall not be laid in those subsoils that are likely to affect adversely the quality or strength of concrete. Where these pipes are employed for conveying liquid containing sulphates, the pipes used shall be manufactured using sulphate resisting Portland cement. Owing to the longer lengths of pipes available, the joints would be lesser in the case of cement concrete pipes. These pipes may be used for surface water drains in all diameters. Cement concrete pipes shall conform to accepted standards [9-2(5)].

4.3.2.3 Cast iron pipes

4.3.2.3.1 These pipes shall be used in the following situation:

- a) In bed or unstable ground where soil movement is expected;
- b) In made-up or tipped ground;
- c) To provide for increased strength where a sewer is laid at insufficient depth, where it is exposed or where it has to be carried on piers or above ground;
- d) Under buildings and where pipes are suspended in basements and like situations;
- e) In reaches where the velocity is more than 2.4 m/s; and
- f) For crossings of watercourses.

NOTE — In difficult foundation condition such as in the case of black cotton soil, the cast iron pipes shall be used only when suitable supporting arrangements are made.

4.3.2.3.2 It shall be noted that cast iron pipes even when given a protective paint are liable to severe external corrosion in certain soils; among such soils are:

- a) Soils permeated by peaty waters; and
- b) Soils in which the subsoil contains appreciable concentrations of sulphates. Local experiences shall be ascertained before cast iron pipes are used where corrosive soil conditions are suspected. Where so used, suitable measures for the protection of the pipes may be resorted to as an adequate safeguard.

4.3.2.3.3 Cast iron pipes shall conform to accepted standards [9-2(6)].

4.3.2.4 Asbestos cement pipes

Asbestos cement pipes are commonly used for house drainage systems and they shall conform to accepted standards [9-2(7)]. They are not recommended for underground situations. However, asbestos cement pressure pipes conforming to accepted standards [9-2(7)] may be used in underground situations also, provided they are not subject to heavy superimposed

loads. These shall not be used to carry acid effluents or sewage under conditions favourable for the production of hydrogen sulphide and shall not be laid in those subsoils which are likely to affect adversely the quality or strength of asbestos cement pipes. Where so desired, the life of asbestos cement pipes may be increased by lining inside of the pipe with suitable coatings like epoxy/polyester resins, etc.

4.3.2.5 PVC pipes

Unplasticized PVC pipes may be used for drainage purposes; however, where hot water discharge is anticipated, the wall thickness shall be minimum 3 mm irrespective of the size and flow load.

PVC and HDPE pipes shall conform to accepted standards [9-2(8)].

NOTE — Where possible, high density polyethylene pipes (HDPE) and PVC pipes may be used for drainage and sanitation purposes, depending upon the suitability.

4.3.2.6 Corrugated pipes

These pipes (externally corrugated) are used for sewerage and drainage applications. They are light weight and have long life. The leakage and infiltration at joints are less. The operational cost is low and can easily withstand natural settlements without suffering cracks or leakages. They consume fewer raw material and have less carbon dioxide emission.

4.3.2.7 Low noise pipes

Waste water systems encompass the system of drainage and pressure relief pipes within a building and terminate 0.5 m outside the external wall. Waste water systems are based on the primary pressure-relief system in which water and air-flow occurs in the same pipe. The waste water system shall be separated from the roof drainage system.

Noise is a variance in air pressure that spreads like a wave. If quick changes in pressure occur between 20 and 20 000 times a second (frequency 20 Hz and 20 kHz), they are audible to humans. The loudness of noise is determined by the amplitude of the wave, which is measured in decibels (dB).

The main cause of noise in indoor drainage systems (primarily focused on the downpipe) are the choice of the pipe system, the bracket type and the design of drainage system. Optimizing these factors will therefore have the best influence on noise reduction.

4.3.2.8 Under slung pipes

In under slung plumbing, the toilet slab is built at the same level as the slabs outside the toilet. Holes/core cuts are punctured through the slab wherever pipes have to pass through, and the plumbing is clamped to the

bottom of the slab. It is then concealed above a false ceiling, which is accessible above the false ceiling for routine maintenance. In this type of plumbing, any leaks will drip onto the false ceiling which is easily detectable thus allow quick maintenance without much damage to the structure or occupied premises

4.4 Preliminary Data for Design

4.4.1 General

Before the drainage system for a building or group of buildings is designed and constructed, accurate information regarding the site conditions is essential. This information may vary with the individual scheme but shall, in general, be covered by the following:

- a) Site plan (*see 3.2.2*).
- b) Drainage plan (*see 3.2.3*).
- c) *Use* — A description of the use for which the building is intended and periods of occupation in order that peak discharges may be estimated;
- d) *Nature of waste* — While dealing with sewage from domestic premises, special problems under this head may not arise; however, note shall be taken of any possibility of trade effluents being discharged into the pipes at a future date;
- e) *Outlet connection* — The availability of sewers or other outlets;
- f) *Cover* — The depth (below ground) of the proposed sewers and drains and the nature and weight of the traffic on the ground above them;
- g) *Subsoil condition*
 - 1) The approximate level of the subsoil water, and any available records of flood levels shall be ascertained, as also the depth of the water table relative to all sewer connections, unless it is known to be considerably below the level of the latter.
 - 2) In the case of deep manholes, this information will influence largely the type of construction to be adopted. The probable safe bearing capacity of the subsoil at invert level may be ascertained in the case of a deep manhole.
 - 3) Where work of any magnitude is to be undertaken, trial pits or boreholes shall be put at intervals along the line of the proposed sewer or drain and the data therefrom tabulated, together with any information available from previous works carried out in the vicinity. In general, the information derived from

trial pits is more reliable than that derived from boreholes. For a long length of sewer or drain, information derived from a few trial pits at carefully chosen points may be supplemented by that obtained from number of intermediate boreholes.

Much useful information is often obtained economically and quickly by the use of a soil auger.

- 4) The positions of trial pits or boreholes shall be shown on the plans, together with sections showing the strata found and the dates on which water levels are recorded.
- h) *Location of other services* — The position, depth and size of all other pipes, mains, cables, or other services, in the vicinity of the proposed work, may be ascertained from the Authority, if necessary;
- j) *Reinstatement of surfaces* — Information about the requirements of the highway authority is necessary where any part of the sewer or drain is to be taken under a highway. Those responsible for the sewer or drain shall be also responsible for the maintenance of the surface until permanently reinstated. The written consent of the highway authority to break up the surface and arrangement as to the charges thereof and the method and type of surface reinstatement shall always be obtained before any work is commenced;
- k) *Diversion and control of traffic*
 - 1) In cases where sewers cross roads or foot-paths, cooperation shall be maintained with the police and Authorities regarding the control and diversion of vehicular and/or pedestrian traffic as may be necessary. Access to properties along the road shall always be maintained and adequate notice shall be given to the occupiers of any shops or business premises, particularly if obstruction is likely.
 - 2) During the period of diversion, necessary danger lights, red flags, diversion boards, caution boards, watchmen, etc, shall be provided as required by the Authority.
- m) *Way-leaves (easements)* — The individual or authority carrying out the work is responsible for negotiating way-leaves where the sewer crosses land in other ownership. The full extent and conditions of such way-leaves shall be made known to the contractor and his employees, and prior notice of commencement of excavation shall always be given to the owners concerned, and cooperation with them

shall be maintained at all stages, where sewers run across fields or open ground, the exact location of manholes shall be shown on way-leaves or easement plans. The right of access to manhole covers and the right to maintain the sewer shall be specifically included in any way-leave or easement arrangements which may be made with the owner of the land; and

- n) *Damage to buildings and structures* — When sewer trenches have to be excavated near buildings or walls a joint inspection with the owners of the property shall be made to establish whether any damage or cracks exist before starting the work, and a properly authenticated survey and record of the condition of buildings likely to be affected shall be made. Tell tales may be placed across outside cracks and dated, and kept under observation. Un-retouched photographs taken by an independent photographer may provide useful evidence.

4.4.2 Drainage into a Public Sewer

Where public sewerage is available, the following information is particularly necessary and may be obtained from the Authority:

- a) The position of the public sewer or sewers in relation to the proposed buildings.
- b) The invert level of the public sewer;
- c) The system on which the public sewers are designed (combined, separate or partially separate), the lowest level at which connection may be made to it, and the Authority in which it is vested;
- d) The material of construction and condition of the sewer if connection is not to be made by the Authority;
- e) The extent to which surcharge in the sewer may influence the drainage scheme;
- f) Whether the connection to the public sewer is made, or any part of the drain laid, by the Authority, or whether the owner is responsible for this work; if the latter, whether the Authority imposes any special conditions;
- g) Whether an intercepting trap is required by the Authority on the drain near the boundary of the curtilage; and
- h) Where manholes are constructed under roads, the approval of the Highway Authority for the type of cover to be fitted shall be obtained.

4.4.3 Other Methods of Disposal of Sewage

4.4.3.1 Where discharge into a public sewer is not possible, the drainage of the building/building campus shall be on a separate system. Foul water shall be

disposed of by adequate treatment approved by the Authority on the site. The effluent from the plant shall be discharged after meeting the norms specified by the statutory authority into a natural watercourse or on the surface of the ground or disposed of subsoil dispersion preferably draining to a suitable outlet channel.

4.4.3.2 In the case of dilution into a natural stream course, the quality of the effluent shall conform and the requirements of the Authority controlling the prevention of pollution of streams.

4.4.3.3 In the case of subsoil dispersion, the requirements of the Authority for water supply shall be observed to avoid any possible pollution of local water supplies or wells.

4.4.3.4 The general subsoil water level and the subsoil conditions shall be ascertained, including the absorptive capacity of the soil.

4.4.3.5 A subsoil dispersion is not desirable near a building or in such positions that the ground below the foundations is likely to be affected.

4.4.3.6 Where no other method of disposal is possible, foul water may be diverted to cesspools and arrangements made with the Authority for satisfactory periodical removal and conveyance to a disposal works.

4.4.3.7 Under the separate system, drainage of the building shall be done through septic tanks of different sizes or by stabilization ponds or by any other treatment methods such as extended aeration activated process, sequential batch process, fluidized bio-reactors, membrane bio-reactor, submerged aerobic fixed film, rotating biological contactor, electrolyte process, etc, as approved by the Authority.

For detailed information on the design and construction of septic tanks and waste stabilization ponds, sewage treatment plants reference may be made to good practice [9-2(9)].

4.4.3.8 Bio-toilet (or eco-toilet)

It is useful in situations where no suitable water supply or sewer system and sewage treatment plant is available to capture the nutrients in human excreta.

The toilet is made of a structure, generally of prefabricated type, above the ground, a bio-digester tank below the ground and in case of sub-zero temperature regions, a solar panel. Bio-toilet involves complete sludge free disposal of human waste and eliminates need for manual scavenging. It decomposes solid waste to water and bio-gas. It is eco-friendly, hazard free, requiring least maintenance and is capable of functioning efficiently at sub-zero temperatures (*see Fig. 5*)

4.4.4 Disposal of Surface and Subsoil Waters

All information which may influence the choice of methods of disposal of surface and/or subsoil waters shall be obtained. In the absence of surface water drainage system, and if practicable and permissible, disposal into a natural water-course or soakaway may be adopted. The location and flood levels of the water course as also the requirements of the Authority controlling the river or the waterway shall be ascertained.

4.5 Planning and Design Considerations

4.5.1 Aim

The efficient disposal of foul and surface water from a building is of great importance to public health and is

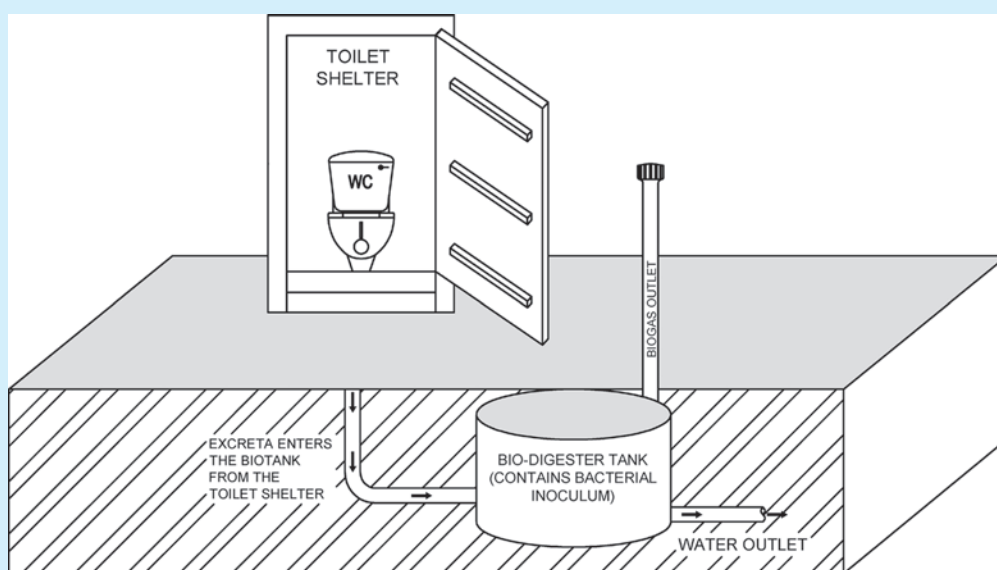

FIG. 5 BIO-TOILET OR ECO-TOILET

an essential part of the construction of the building. In designing a drainage system for an individual building or a housing colony, the aim shall be to provide a system of self-cleaning conduits for the conveyance of foul, waste, surface or subsurface waters and for the removal of such wastes speedily and efficiently to a sewer or other outlet without risk of nuisance and hazard to health. Also, intent should be to take into consideration that, waste water, storm water and solid waste are potential resources.

4.5.1.1 To achieve this aim, a drainage system shall satisfy the following requirements:

- a) Rapid and efficient removal of liquid wastes without leakage;
- b) Prevention of access of foul gases to the building and provision for their escape from the system.
- c) Adequate and easy access for clearing obstructions;
- d) Prevention of undue external or internal corrosion, or erosion of joints and protection of materials of construction; and
- e) Avoidance of air locks, siphonage, proneness to obstruction, deposit and damage.

4.5.1.2 The realization of an economical drainage system is added by compact grouping of fittings in both horizontal and vertical directions. This implies that if care is taken and ingenuity brought into play when designing the original building or buildings to be drained, it is possible to group the sanitary fittings and other equipment requiring drainage; both in vertical and horizontal planes, as to simplify the drainage system and make it most economical.

4.5.1.3 Efficient and an economical plumbing system can be achieved by planning the toilets in compact grouping with the layout of the bathrooms and observing the following guidelines:

- a) Placing of plumbing fixtures around an easily accessible pipe shaft; in high rise buildings the pipe shafts may have to be within the building envelope and easy provision for access panels and doors should be planned in advance, in such cases so as not to cause inconvenience during maintenance.
- b) Adopting repetitive layout of toilets in the horizontal and vertical directions.
- c) In planning for malls, the required public and toilet facilities shall be located not more than one storey above or below the space to be served with such facilities, and the path of travel to such facilities shall not exceed 91 m.

In other occupancies, the required public and toilet facilities shall be located not more than one storey above or below the space to be served with such facilities, and the path of travel to such facilities shall not exceed 152 m.

However, in the above buildings, toilet rooms shall not open directly into a room used for preparation of food for service to public.

- d) Avoiding any conflict with the reinforced cement concrete structure by avoiding embedding pipes in it, avoiding pipe crossings in beams, columns and major structural elements.
- e) Identifying open terraces and areas subject to ingress of rainwater directly or indirectly and providing for location of inlets at each level for down takes for disposal at ground levels.
- f) Avoiding crossing of services of individual property through property of other owners.
- g) Planning to avoid accumulation of rainwater or any backflow from sewers particularly in planned low elevation areas in a building.
- h) *Setting of sanitary fixtures* — A water closet, urinal, lavatory or bidet shall not be set closer than 380 mm from the centre to any side wall partition, vanity or other obstruction, or closer than 760 mm centre-to-centre between adjacent fixtures. There shall not be less than 530 mm clearance in front of the water closet, urinal, lavatory or bidet to any wall, fixture or door. Water closet compartment shall not be less than 760 mm in width and 1 520 mm in depth for floor mounted closets, and not less than 760 mm in width and 1 420 mm in depth for wall hung water closets.

The urinal partitions shall begin at a height not greater than 305 mm from and extend not less than 1 520 mm above the finished floor surface. The walls or partitions shall extend from the wall surface at each side of the urinal not less than 460 mm or to a point not less than 150 mm beyond the outermost front lip of the urinal measured from the finished back wall surface, whichever is greater.

- j) Usually, the vertical distance between two horizontal connections to a vertical drain should be more than 200 mm in order to avoid back flow.

4.5.1.4 Typical mounting arrangements for various plumbing fixtures, including drainage systems and ventilation are illustrated in Annex D.

4.5.2 Layout

4.5.2.1 General

Rainwater should preferably be dealt separately from sewage and sullage. Sewage and sullage shall be connected to sewers. However, storm water from the courtyard may be connected to the sewer where it is not possible to drain otherwise; after obtaining permission of the Authority.

4.5.2.2 Additional requirements

The following requirements are suggested to be considered in the design of drainage system:

- a) The layout shall be as simple and direct as practicable.
- b) The pipes should be laid in straight lines, as far as possible, in both vertical and horizontal planes.
- c) Anything that is likely to cause irregularity of flow, such as abrupt changes of direction, shall be avoided.
- d) The pipes should be non-absorbent, durable, smooth in bore and of adequate strength.
- e) The pipes should be adequately supported without restricting movement.
- f) Drains should be well ventilated, to prevent the accumulation of foul gases and fluctuation of air pressure within the pipe, which could lead to unsealing (siphoning) of gully or water closet traps.
- g) All the parts of the drainage system should be accessible for feasibility of inspection and practical maintenance.
- h) No bends and junctions whatsoever shall be permitted in sewers except at manholes and inspection chambers.
- j) Sewer drain shall be laid for self-cleaning velocity of 0.75 m/s and generally should not flow more than half-full.
- k) Pipes crossing in walls and floors shall be through mild steel sleeves of diameter leaving an annular space of 5 mm around the outer diameter of the pipe crossing the wall.
- m) Pipes should not be laid close to building foundation.
- n) Pipes should not pass near large trees because of possibility of damage by the roots.
- p) Branch connections should be swept in the direction of flow.
- q) Sewer pipes should be at least 900 mm below road and at least 600 mm below fields and gardens.
- r) Pipes should not pass under a building unless

absolutely necessary. Where it is necessary to lay pipes under a building, the following conditions shall be observed:

- 1) Pipes shall be centrifugally cast (spun) iron pressure pipe as per good practice [9-2(10)];
- 2) The pipe shall be laid in straight line and at uniform gradient;
- 3) Means of access in form of manholes/ inspection chamber shall be provided at each end, immediately outside the building;
- 4) In case the pipe or any part of it is laid above the natural surface of the ground, it shall be laid on concrete supports, the bottom of which goes at least 150 mm below the ground surface.

NOTE — It is desirable that pipe/drains should not be taken through a living room or kitchen and shall preferably be taken under a staircase room or passage.

- s) Consideration shall be given to alternative layouts so as to ensure that the most economical and practical solution is adopted. The possibility of alterations shall be avoided by exercising due care and forethought.

4.5.2.3 Protection against vermin and dirt

The installation of sanitary fittings shall not introduce crevices which are not possible to inspect and clean readily.

Pipes, if not embedded, shall be run well clear of the wall. Holes through walls to lay pipes shall be made good on both sides to prevent entry of insects. Materials used for embedding pipes shall be rodent-proof. Passage of rodents from room-to-room or from floor-to-floor shall be prevented by suitable sealing. The intermediate lengths of ducts and chases shall be capable of easy inspection. Any unused drains, sewers, etc, shall be demolished or filled in to keep them free from rodents.

All pipe shafts shall be plastered before any pipes are installed in the shaft. It is advisable to lay pipes on the steel supports with adequate gap between plastered wall and support structure. This will provide a smooth surface and prevent location for survival of insects and vermins.

4.5.2.4 Choice of plumbing system

4.5.2.4.1 In selecting one or more of the type of piping systems, the building and the layout of toilets/fixtures, relationship with other services, acceptability to the Authority, and any special requirements of users, shall be studied.

- a) *Single stack system* [see 2.69 (a)]
- 1) The single stack system is ideal when the toilet/fixture layouts are repetitive and there is less space for pipes on the wall.
 - 2) In any system so selected there should be not more than two toilet connections per floor.
 - 3) The system requires minimum 100 mm diameter stack for a maximum of 5 floors in a building.
 - 4) In this system, care shall be taken of the horizontal distance of sanitary fixtures from the drainage stack and vertical distance between connections of branches from fixtures to drainage stack.
 - 5) All the safeguards for the use of this system given in 4.5.2.4.2 shall be complied with.

- b) *One pipe — partially ventilated system* [see 2.69 (b)]

The system and the applicable safeguards under this system are the same as for single stack system. The prime modification is to vent the soil appliance(s).

- c) *One pipe — fully ventilated system* [see 2.69 (c)]

- 1) This system is suitable for buildings where the toilet/fixture layouts and the shafts are repetitive. It requires less shaft space, and is economical.
- 2) Continuous flow of water in the pipe from waste appliances makes it less prone to blockage and makes the system more efficient.
- 3) The system eliminates the need for a gully trap which requires constant cleaning.
- 4) This system requires individual vent pipes installed either in suspended ceiling or in the wall above the floor level in the toilet, provided construction details of the building allow provision of vent pipes for individual fixtures and routing of vent pipes to remote shafts where main vent stacks may have been located.
- 5) The system requires minimum 100 mm diameter stack.
- 6) The system is ideal when the main pipes run at the ceiling of the lowest floor or in a service floor.

- d) *Two pipe system* [see 2.69 (d)]

- 1) This system provides safety and flexibility in layouts for larger toilets and for buildings having higher requirement

of performance due to its height and type of occupancy.

- 2) In large buildings and houses with open ground and gardens, the sullage water from the waste system can be suitably treated and usefully utilized for gardening and agriculture.
- 3) In larger and multi-storeyed buildings, the sullage is treated within the building for reuse as makeup water for cooling towers for air conditioning system and is also used for flushing water closets provided it has absolutely no connection with any water supply line, tank or system used for domestic and drinking supply.

For detailed information regarding design and installation of soil, waste and vent pipes, reference may be made to good practice [9-2(11)].

4.5.2.4.2 Safeguards for single stack system

- a) As far as practicable, the fixtures on a floor shall be connected to stack in order of increasing discharge rate in the downward direction.
- b) The size of the vent pipe (terminating to the outdoor) shall be same as the size of drainage stack in the case of single stack system.
- c) Water closets shall be connected to the stack through a sanitary tee; the maximum horizontal distance from the stack being 2 400 mm.
- d) For fixtures other than water closets, the maximum horizontal distance from the stack shall be 3 500 mm.
- e) The vertical distance between the waste branch (from floor trap or from the individual appliance) and the soil branch connection, when soil pipe is connected to stack above the waste pipe, shall be not less than 200 mm.
- f) Depth of water seal traps from different fixtures shall be as per 4.5.3.6.1.6.
- g) Branches and stacks which receive discharges from WC pans should not be less than 100 mm, except where the outlet from the siphonic water closet is 80 mm, in which case a branch pipe of 80 mm may be used. For outlet of floor traps 75 mm dia pipes may be used.
- h) The horizontal branch distance for fixtures from stack, bend(s) at the foot of stack to avoid back pressure as well as vertical distance between the lowest connection and the invert of drain shall be as per good practice [9-2(11)].
- j) For tall buildings, ground floor appliances are recommended to be connected directly to manhole/inspection chamber.

4.5.2.4.2.1 Drainage stack shall be sized in accordance with Table 16. The drainage stack and branch piping shall be the vents for the drainage system. Stack shall be uniformly sized based on the total connected drainage fixture unit load.

Table 16 Single Stack Sizing
(Clause 4.5.2.4.2.1)

Sl No.	Stack Size mm	Maximum Connected Drainage Fixture Units (DFU)		
		Stacks Less than 23 m in Height	Stacks 23 m to Less than 49 m in Height	Stacks 49 m and Greater in Height ¹⁾
(1)	(2)	(3)	(4)	(5)
i)	75	24	—	—
ii)	100	225	24	—
iii)	125	480	225	24
iv)	150	1 015	480	225
v)	200	2 320	1 015	480
vi)	250	4 500	2 320	1 015
vii)	300	8 100	4 500	2 320
viii)	375	13 600	8 100	4 500

¹⁾ To be considered for one-pipe partially ventilated system only.

4.5.2.4.2.2 An alternative design approach for designing the single stack system is also used in some of the countries, which may be followed if approved by the authority. Such an approach may utilize the following, and may also require reference to available specialist literature:

- a) The size of the vent pipe (terminating to the outdoor) shall be same as the size of drainage stack in the case of single stack system.
- b) Using branch discharge pipes, self and external siphonage of the water seal of traps can be avoided.
- c) In respect of branch discharge pipes, the entire developed length including fittings up to farthest connection is 4.0 m.
- d) A 45° bend shall be used for the horizontal branch pipe with a drop connection after the connection from the appliance.
- e) To match the crowns of small and larger pipes, an eccentric reducer is used with straight portion on top.
- f) A non-ventilated discharge pipe shall be connected to discharge stack with a sweep junction having an angle of 87° to 88.5°.
- g) In respect of vertical discharge stacks, concentric or eccentric reducers may be permitted.
- h) In respect of stacks not exceeding 10 m in height, from the upper most connection to change of direction, no branch discharge pipe

shall be connected to the stack or horizontal side for a distance of 1.0 m. In respect of second change in direction, no branch discharge pipe shall be connected within a distance of 0.5 m after the change of direction. The pipe stack shall not be connected to sanitary appliances from the lowest floor.

- j) In respect of stacks exceeding 10 m in height, from the upper most connection to change of direction, no branch discharge pipe shall be connected to the stack or horizontal side for a distance of 2.0 m. The connection of the ventilated branch to the main stack shall not be within 2.0 m from the change of direction. In respect of second change in direction, no branch discharge pipe shall be connected within a distance of 0.5 m after the change of direction. The pipe stack shall not be connected to sanitary appliances from the lowest floor.
- k) The connection of branch discharge pipes to the vertical stack shall be such that back flow will not cross flow into fixtures on the opposite ends.

4.5.3 Drainage (Soil, Waste and Vent) Pipes

4.5.3.1 General considerations

4.5.3.1.1 Drainage pipes shall be kept clear of all other services. Provisions shall be made during the construction of the building for the entry of the drainage pipes. In most cases this may be done conveniently by installing sleeves or conduit pipes into or under the structure in appropriate positions. This will facilitate the installation and maintenance of the services.

4.5.3.1.2 Horizontal drainage piping should be so routed as not to pass over any equipment or fixture where leakage from the line could possibly cause damage or contamination. Drainage piping shall never pass over switch-gear or other electrical equipment. If it is impossible to avoid these areas and piping shall run in these locations, then a pan or drain tray should be installed below the pipe to collect any leakage or condensation. A drain line should run from this pan to a convenient floor drain or service sink.

4.5.3.1.3 All vertical soil, waste, vent and anti-siphonage pipes shall be covered on top with a copper or heavily galvanized iron wire dome or cast iron terminal guards. All cast iron pipes, which are to be painted periodically, shall be fixed to give a minimum clearance of 50 mm clear from the finished surface of the wall by means of a suitable clamp.

NOTE — Asbestos cement cowls may be used in case asbestos cement pipes are used as soil pipes.

4.5.3.1.4 Drainage pipes shall be carried to a height above the buildings as specified for vent pipe (see 4.5.3.4).

4.5.3.2 Soil pipes

A soil pipe, conveying to a drain, any solid or liquid filth, shall be circular and shall have a minimum diameter of 100 mm.

4.5.3.2.1 Except where it is impracticable, the soil pipe shall be situated outside the building or in suitably designed pipe shafts and shall be continued upwards without diminution of its diameter, and (except where it is unavoidable) without any bend or angle, to such a height and position as to afford by means of its open end a safe outlet for foul air. The position of the open end with its covering shall be such as to comply with the conditions set out in **4.5.3.4** relating to vent pipe. Even if the pipes are laid externally, the soil pipes shall not be permitted on a wall abutting a street unless the Authority is satisfied that it is unavoidable. Where shafts for pipes are provided, the cross-section area of the shaft shall be suitable to allow free and unhampered access to the pipes and fittings proposed to be installed in the shaft. However, in no case cross-section area of the shaft shall be less than a square of 1 m side. All pipe shafts shall be provided with an access door at ground level and facilities for shaft ventilation.

4.5.3.2.2 Soil pipes, whether insider or outside the building, shall not be connected with any rainwater pipe and there shall not be any trap in such soil pipe or between it and any drain with which it is connected.

4.5.3.2.3 The soil pipe shall be provided with heel rest bend which shall rest on sound footing, if terminating at firm ground level. When the stack is terminating at the ceiling of a floor, the bend shall be provided with sufficient structural support to cater for the stack dead weight and the thrust developed from the falling soil/waste. Vertical stack shall be fixed at least 50 mm clear of the finished surface of the wall by means of a suitable clamp of approved type.

4.5.3.3 Waste pipes

Every pipe in a building for carrying off the waste or overflow water from every bath, wash basin or sink to a drain shall be of 32 mm to 50 mm diameter, and shall be trapped immediately beneath such wash basins or sink by an efficient siphon trap — P trap with adequate means for inspection and cleaning. Such P traps shall be ventilated into the external air whenever such ventilation is necessary to preserve the seal of the trap. Waste pipes, P traps, etc, shall be constructed of iron, lead, brass, PVC, engineering plastics, stoneware, asbestos cement or other approved material. The overflow pipe from wash basin, sinks, etc, shall be connected with the waste pipe immediately above the

trap. Vertical pipes carrying off waste water shall have a minimum diameter of 75 mm.

NOTE — Whenever wash basins and sinks have in-built overflow arrangements, there is no need to provide overflow pipes in such cases.

4.5.3.3.1 Every pipe in a building for carrying off waste water to a drain shall be taken through an external wall of the building by the shortest practicable line, and shall discharge below the grating or surface box of the chamber but above the inlet of a properly trapped gully. The waste pipe shall be continued upwards without any diminution in its diameter and (except when unavoidable) without any bend or angle to such a height and position as to afford by means of the open end of the waste pipe, a safe outlet for foul air, the position of the open end and its covering being such as to comply with the conditions.

4.5.3.3.2 Except where it is impracticable, the common waste pipe shall be situated outside the building and shall be continued upwards without diminution of its diameter (except where it is unavoidable) without any bend or angle being formed to such a height and position as to avoid by means of the open end a safe outlet for foul air, the position of the open end and the covering threat being such as to comply with the conditions set out in **4.5.3.4** relating to vent pipe.

4.5.3.4 Vent pipes

Vent pipes should be so installed that water cannot be retained in them. They should be fixed vertically. Whenever possible, horizontal runs should be avoided. Vent pipe shall be carried to such a height and in such a position as to afford by means of the open end of such pipe or vent shaft, a safe outlet for foul air with the least possible nuisance.

4.5.3.4.1 The upper end of the main vent pipe may be continued to the open air above roof level as a separate pipe, or it may join the MSP and/or MWP above the floor level of the highest appliance. Its lower end may be carried down to join the drain, at a point where air relief may always be maintained.

4.5.3.4.2 Branch vent pipes should be connected to the top of the BSP and BWP between 75 mm and 450 mm from the crown of the trap.

4.5.3.4.3 The vent pipe shall always be taken to a point 1 500 mm above the level of the eaves or flat roof or terrace parapet whichever is higher or the top of any window within a horizontal distance of 3 m. The least dimension shall be taken as a minimum and local conditions shall be taken into account. The upper end of every vent pipe shall be protected by means of a cowl.

4.5.3.4.4 In case the adjoining building is taller, the vent pipe shall be carried higher than the roof of the adjacent building, wherever it is possible.

4.5.3.4.5 The building drain intended for carrying waste water and sewage from a building shall be provided with at least one vent pipe situated as near as practicable to the building from an inspection chamber and as far away as possible from the point at which the drain empties into the sewer or other carrier.

4.5.3.4.6 *Size of vent pipe*

- a) The building drain vent pipe shall be of not less than 75 mm diameter. When, however, it is used as MSP or MWP, the upper portion, which does not carry discharges, shall not be of lesser diameter than the remaining portion;
- b) The diameter of the main vent pipe in any case should not be less than 50 mm;
- c) A branch vent pipe on a waste pipe in both one and two-pipe systems shall be of not less than two-thirds the diameter of the branch waste pipe, subject to a minimum of 25 mm; and
- d) A branch vent pipe on a soil pipe in both one and two-pipe systems shall be not less than 32 mm in diameter.
- e) Vent pipes to be sized/designed considering the drainage fixture units of individual fixtures/appliances as per good engineering practices (see 4.5.3.4.7).

4.5.3.4.7 *Venting system for high rise buildings*

In the case of fully ventilated system, suitable sized pipe stacks carry soil and waste drainage, wherein each sanitary fixture is individually vented. The practical way of implementation of this system is by venting each water closet and floor drain. A fully ventilated one pipe drainage system is most popular in advanced plumbing installations.

Properly sized vent pipe would ensure maintenance of atmospheric pressure within gravity drainage pipes.

Sizing of vent pipe is based on cumulative drainage fixture units of all fixtures served by the pipe. Sizing also depends on maximum permissible lengths. Maximum lengths are also subject to the limitation that one-third of length shall be horizontal. Horizontal pipes always rise towards termination point, avoiding vertical loops.

The minimum required diameter of stack vents and vent stacks shall be determined from the developed length and the total drainage fixture units (DFU) connected thereto, in accordance with Table 17. However, in no case, the diameter shall be less than half the diameter of the drain served or less than 32 mm.

NOTE — In case, if fully ventilated one-pipe system is not implemented then it shall indicate the case of two-pipe system

along with common vent pipe for which the guideline for sizing shall be provided. Also, it shall provide a sketch for two-pipe system along with connection of branch pipes from wash basin to the deep seal trap through inlet fitting as per prevailing conditions as approved by Authority.

4.5.3.5 *Design of drainage pipes*

A stack is the main vertical pipe that carries away discharge from water closets and urinals (soil stack) or other clear waste water from equipment (waste stack) with adequate suitable fittings, which may be a long-turn, tee-wye or short-turn or sanitary tee. Depending on the rate of flow in to the drain stack, the diameter of the stack, the type of stack fittings and the flow down the stack from higher levels (if any), the discharge from the fixture drain may or may not fill the cross-section of the stack at the level of entry. In any event, as soon as the water enters the stack, the force of gravity rapidly accelerates it downward and before it travels very far, it assumes the form of a sheet around the wall of the stack, leaving the centre of the pipe open for the flow of air.

This sheet of water continues to accelerate until the frictional force exerted by the wall of the falling sheet of water equals the gravitational force. If the distance the water travel is sufficient enough and provided that no flow enters the stack at lower levels to interfere the sheet, the sheet remains unchanged in thickness and velocity until it reaches the bottom of the stack. The ultimate vertical velocity the sheet attains is called the 'terminal velocity'. The distance the sheet must fall to attain this terminal velocity is called the 'terminal length'.

Following formulae may be used for calculating the terminal velocity and terminal length:

$$V_t = 3.0 (Q/d)^{2/5}$$

$$L_t = 0.052 V_t^2$$

where

V_t = terminal velocity in the stack, m/s;

L_t = terminal length below the point of flow entry, m;

Q = quantity rate of flow, l/s; and

d = diameter of stack, mm.

At the centre of the stack is a core of air that is dragged along with the water by friction. A supply source of air shall be provided to avoid excessive pressures in the stack. The usual means of supplying this air are through the stack vent or vent stack. The entrained air in the stack causes a pressure reducing inside the stack, which is caused by the frictional effect of the falling sheet of water dragging the core of air with it.

4.5.3.5.1 *Estimation of maximum flow of sewer*

a) *Simultaneous discharge flow*

- 1) The maximum flow in a building drain or a stack depends on the probable maximum number of simultaneous discharging appliances. For the

- calculation of this peak flow certain loading factors have been assigned to appliances in terms of fixture units, considering their probability and frequency of use. These fixture unit values are given in Table 18.
- 2) For any fixtures not covered under Table 18, Table 19 may be referred to for deciding their fixture unit rating depending on their drain or trap size.
 - 3) From Tables 18 and 19, the total load on any pipe in terms of fixtures units may be calculated knowing the number and type of appliances connected to this pipe.
 - 4) For converting the total load in fixture units to the peak flow in litre per minute, Fig. 6 is to be used.
 - 5) The maximum number of fixture units that are permissible for various recommended pipe size in the drainage system are given in Table 20 and Table 21.
 - 6) Results should be checked to see that the soil, waste and building sewer pipes are not reduced in diameter in the direction of flow. Where appliances are to be added in fixture, these should be taken into account in assessing the pipe sizes by using the fixture units given in Table 18 and Table 19.

Table 17 Size and Developed Length of Stack Vents and Vent Stacks
(Clause 4.5.3.4.7)

SI No.	Diameter of Soil and / or Waste Stack mm	Total Fixture Units Being Vented (DFU)	Maximum Developed Length of Vent for the Diameter of Vent											
			m											
			32 mm	40 mm	50 mm	65 mm	75 mm	100 mm	125 mm	150 mm	200 mm	250 mm	300 mm	
(1)	(2)	(3)	(4)	(5)	(6)	(7)	(8)	(9)	(10)	(11)	(12)	(13)	(14)	
i)	32	2	9	—	—	—	—	—	—	—	—	—	—	—
ii)	40	8	15	45	—	—	—	—	—	—	—	—	—	—
iii)	40	10	9	30	—	—	—	—	—	—	—	—	—	—
iv)	50	12	—	23	61	—	—	—	—	—	—	—	—	—
v)	50	20	9	15	45	—	—	—	—	—	—	—	—	—
vi)	65	42	8	9	30	91	—	—	—	—	—	—	—	—
vii)	75	10	—	13	45	110	317	—	—	—	—	—	—	—
viii)	75	21	—	10	34	82	247	—	—	—	—	—	—	—
ix)	75	53	—	8	29	70	207	—	—	—	—	—	—	—
x)	75	102	—	—	26	64	189	—	—	—	—	—	—	—
xi)	100	43	—	8	11	26	76	299	—	—	—	—	—	—
xii)	100	140	—	—	8	20	61	229	—	—	—	—	—	—
xiii)	100	320	—	—	7	17	52	195	—	—	—	—	—	—
xiv)	100	540	—	—	6	15	46	177	—	—	—	—	—	—
xv)	125	190	—	—	—	8.5	25	98	302	—	—	—	—	—
xvi)	125	490	—	—	—	6.4	19	76	232	—	—	—	—	—
xvii)	125	940	—	—	—	5.5	16	64	204	—	—	—	—	—
xviii)	125	1 400	—	—	—	4.9	15	58	180	—	—	—	—	—
xix)	150	500	—	—	—	—	10	40	122	305	—	—	—	—
xx)	150	1 100	—	—	—	—	8	30	94	238	—	—	—	—
xxi)	150	2 000	—	—	—	—	7	26	79	201	—	—	—	—
xxii)	150	2 900	—	—	—	—	6	23	73	183	—	—	—	—
xxiii)	200	1 800	—	—	—	—	—	9	29	73	287	—	—	—
xxiv)	200	3 400	—	—	—	—	—	7	22	58	222	—	—	—
xxv)	200	5 600	—	—	—	—	—	6	19	49	186	—	—	—
xxvi)	200	7 600	—	—	—	—	—	5	17	43	171	—	—	—
xxvii)	250	4 000	—	—	—	—	—	—	9	24	94	293	—	—
xxviii)	250	7 200	—	—	—	—	—	—	7	18	73	226	—	—
xxix)	250	11 000	—	—	—	—	—	—	6	16	61	192	—	—
xxx)	250	15 000	—	—	—	—	—	—	5	14	55	174	—	—
xxxi)	300	7 300	—	—	—	—	—	—	—	9	37	116	287	—
xxxii)	300	13 000	—	—	—	—	—	—	—	7	29	91	219	—
xxxiii)	300	20 000	—	—	—	—	—	—	—	6	24	76	186	—
xxxiv)	300	26 000	—	—	—	—	—	—	—	5	22	70	152	—
xxxv)	375	15 000	—	—	—	—	—	—	—	—	12	40	94	—
xxxvi)	375	25 000	—	—	—	—	—	—	—	—	9	29	73	—
xxxvii)	375	38 000	—	—	—	—	—	—	—	—	8	25	61	—
xxxviii)	375	50 000	—	—	—	—	—	—	—	—	7	23	55	—

NOTE — The developed length shall be measured from the vent connection to the open air.

- b) **Maximum discharge flow** — The maximum rate of discharge flow shall be taken as thrice the average rate; allowance being made in addition for any exceptional peak discharges. A good average rule is to allow for a flow of liquid wastes from buildings at the rate of 3 litre per minute per 10 persons.

4.5.3.5.2 Gradients

4.5.3.5.2.1 The discharge of water through a domestic drain is intermittent and limited in quantity and, therefore, small accumulations of solid matter are liable to form in the drains between the building and the public sewer. There is usually a gradual shifting of these deposits as discharges take place. Gradients should be sufficient to prevent these temporary accumulations building up and blocking the drains.

- a) **Drainage loads** — Single family dwellings contain plumbing fixtures, such as one or more bathroom groups, each consisting of a toilet, wash basin and bathtub or shower unit, a kitchen sink, dishwasher and washing machine. Large buildings also have other fixtures, slop sinks and drinking water coolers. The important characteristic of these fixtures is that they are not used continuously. Rather, they are used with irregular frequencies that vary greatly during the day. In addition, the various fixtures have quite different discharge characteristics regarding both the average flow rate per use and the duration of a single discharge. Consequently, the probability of all the fixtures in the building operating simultaneously is small.
- b) **Stack capacities** — The criterion of flow capacities in drainage stacks is based on the limitation of the water occupied cross-section to a specified fraction of the cross-section of the stack where terminal velocity exists, as suggested by earlier investigations. Flow capacity can be expressed in terms of the stack diameter and the water cross-section, as follows:

$$Q = 27.8 \times r_s^{5/3} \times D^{8/3}$$

where

Q = capacity, l/s;

r_s = ratio of the cross-sectional area of the sheet of water to the cross-sectional area of the stack; and

D = diameter of the stack, mm.

- c) **Design requirement for high rise buildings drainage system** — Drainage pipe stacks are sized for one third of their carrying capacity. Plumbing codes provides values of drainage fixture units for each fixture. Different values for fixture units are based on the nature of occupancy and the place of installation. Sizing of drainage pipes is based on the cumulative values of drainage fixture units connected to the pipe. A vertical pipe shall always have

larger carrying capacity when compared to horizontal pipe of same size. Carrying capacity of horizontal pipe is dependent on gradient provided. Carrying capacities of vertical pipes are restricted by their maximum permissible lengths. This restriction does not

Table 18 Drainage Fixture Units (DFU) for Different Fixtures with Minimum Pipe Sizes
(Clause 4.5.3.5.1)

Sl No.	Type of Fixture	Application		Minimum Trap Size mm
		Private (3)	Public (4)	
(1)	(2)	(3)	(4)	(6)
i)	Bathroom group (water closet, wash basin, bidet and tub or shower)			
	a) Water closet (flush valve)	8	—	—
	b) Water closet (flush tank)	6	—	—
ii)	Bathtub	3	—	40
iii)	Bar sink	1	2	40
iv)	Ablution faucet/Bidet	1	2	40
v)	Clothes washer	3	3	50
vi)	Dishwasher	2	2	40
vii)	Drinking fountain	—	0.5 (0.75)	32
viii)	Floor drain	1	2	50
ix)	Wash basin	1	1	32
x)	Service or mop basin/sink	1.5	3	50
xi)	Kitchen sink	2	2	40
xii)	Shower	2	2	50
xiii)	Laundry sink	2	2	40
xiv)	Clinical or surgeon's scrub sink	—	6	80
xv)	Urinal (with flush valve)	2	2 (3)	50
xvi)	Urinal (with flush tank)	2	2 (3)	50
xvii)	Urinal with sensor operated	2	2 (3)	50
xviii)	Water closet (flush valve)	4	6 (8)	80
xix)	Water closet (flush tank)	3	4 (6)	80
xx)	Combination fixture (faucet)	1	2	40

NOTES

- 1 A shower head over a bath tub does not increase the fixture unit value.
- 2 Size of floor trap shall be determined by the area of surface water to be drained.
- 3 Wash basins with 32 mm and 40 mm trap have the same load value.
- 4 Trap size shall be consistent with the fixture outlet size.
- 5 For fixtures added to bathroom group, the DFU value is added to those additional fixtures to the bathroom group fixture count.
- 6 No floor traps to be provided inside operating rooms, procedure rooms, AIIR isolation rooms and PE isolation rooms.
- 7 The values given in parentheses pertain to such public use buildings (congregation halls) where an enhanced requirement is expected to be encountered as compared to the normal maximum use in public use buildings.

apply to horizontal pipes. Irrespective of drainage fixture units, the minimum size for the fixture shall be adopted. The minimum size of horizontal pipe is critical to ensure self-cleansing velocities in sewers.

Table 19 Fixture Unit Values for Fixtures Based on Fixture Drain on Trap Size
(Clause 4.5.3.5.1)

SI No.	Fixture Drain on Trap Size	Fixture Unit Value
(1)	(2)	(3)
i)	32 mm and smaller	1
ii)	40 mm	2
iii)	50 mm	3
iv)	65 mm	4
v)	80 mm	5
vi)	100 mm	6

4.5.3.5.2.2 When flow occurs in drain piping, it should not entirely fill the cross-section of the pipe under flow condition. If the pipe were to flow full, pressure fluctuations would occur which could possibly destroy the seal of the traps within the building. Normally, the sewer shall be designed for discharging the peak flow as given in **4.5.3.5.1**, flowing half-full with a minimum self-cleansing velocity of 0.75 m/s. The approximate gradients which give this velocity for the sizes of pipes likely to be used in building drainage and the corresponding discharges when flowing half-full are given in Table 22.

4.5.3.5.2.3 In cases where it is practically not possible to conform to the ruling gradients, a flatter gradient may be used, but the minimum velocity in such cases

shall on no account be less than 0.61 m/s and adequate flushing should be done.

NOTE — Where gradients are restricted, the practice of using a pipe of larger diameter than that required by the normal flow, in order to justify laying at a flatter gradient does not result in increasing the velocity of flow, further this reduces the depth of flow and thus for this reasons the above mentioned practice should be discouraged.

4.5.3.5.2.4 On the other hand, it is undesirable to employ gradients giving a velocity of flow greater than 2.4 m/s. Where it is unavoidable, cast iron pipes shall be used. The approximate gradients, which give a velocity of 2.4 m/s for pipes of various sizes and the corresponding discharge when flowing half-full are given in Table 22.

4.5.3.5.2.5 The discharge values corresponding to nominal diameter and gradient given in Table 22 are based on Manning’s formula ($n = 0.015$).

NOTE — Subject to the minimum size of 100 m, the sizes of pipes shall be decided in relation to the estimated quantity of flow and the available gradient.

4.5.3.6 Drain appurtenances

4.5.3.6.1 Trap

All traps shall be protected against siphonage and back pressure ensuring access to atmospheric air for air circulation and preserving the trap seal in all conditions.

4.5.3.6.1.1 A trap may be formed as an integral trap with the appliance during manufacture or may be a separate fitting called an attached trap which may be connected to the waste outlet of the appliance.

4.5.3.6.1.2 Traps should always be of a self-cleansing pattern. A trap, which is not an integral part of an

Table 20 Horizontal Fixture Branches and Stacks¹⁾
(Clause 4.5.3.5.1)

SI No.	Diameter of Pipe	Maximum Number of Drainage Fixture Units ²⁾ (DFU) that can be Connected to			
		Branch Total for Horizontal Branch	Stacks ³⁾		
(1)	mm	(3)	Total Discharge into One Branch Interval	Total for Stack of Three Branch Intervals or Less	Total for Stack Greater than Three Branch Intervals
(1)	(2)	(3)	(4)	(5)	(6)
i)	32	1	2	2	2
ii)	40	3	2	4	8
iii)	50	6	6	10	24
iv)	65	12	9	20	42
v)	75	20	20	48	72
vi)	100	160	90	240	500
vii)	125	360	200	540	1 100
viii)	150	620	350	960	1 900
ix)	200	1 400	600	2 200	3 600
x)	250	2 500	1 000	3 800	5 600
xi)	300	3 900	1 500	6 000	8 400
xii)	375	7 000	See Note	See Note	See Note

¹⁾ Does not include branches of the building sewer.

²⁾ Depending upon the probability of simultaneous use of appliances considering the frequency of use and peak discharge rate.

³⁾ Stacks shall be sized based on the total accumulated connected load at each story or branch interval. As the total accumulated connected load decreases, stacks are permitted to be reduced in size. Stack diameters shall not be reduced to less than one-half of the diameter of the larger stack size required.

NOTE — Sizing load based on design criteria.

appliance, should be directly attached to its outlet and the pipe should be uniform throughout and have a smooth surface.

4.5.3.6.1.3 The trap should have minimum size of outlet/exit, same as that of largest waste inlet pipe.

4.5.3.6.1.4 Traps for use in domestic waste installations and all other traps should be conveniently accessible and provided with cleansing eyes or other means of cleaning.

4.5.3.6.1.5 The minimum internal diameter for sanitary appliances shall be as follows:

<i>Sl No.</i>	<i>Sanitary Appliance</i>	<i>Minimum Internal Diameter of Waste Outlet mm</i>
i)	Soil appliances:	
a)	Indian and European type water closets	100
b)	Bed pan washers and slop sinks	100
c)	Urinal with integral traps	75
d)	Stall urinals (with not more than 120 mm of channel drainage)	50
e)	Lipped urinal small/large	40
ii)	Waste appliances:	
a)	Drinking fountain	25
b)	Washbasin	32
c)	Bidets	32
d)	Domestic sinks and baths	40
e)	Shower bath trays	40
f)	Domestic bath tubs	50
g)	Hotel and canteen sinks	50
h)	Floor traps (outlet diameter)	75

4.5.3.6.1.6 Depth of water seal traps from different fixtures shall be as follows:

<i>Sl No.</i>	<i>Item</i>	<i>Depth of Seals mm</i>		
		<i>Two Pipe System</i>	<i>One Pipe System</i>	<i>Single Stack System</i>
i)	Water closets	50	50	50
ii)	Floor traps	50	50	50
iii)	Other fixtures, directly connected to the stack:			
a)	Where attached to branch waste pipes of 75 mm dia or more	40	40	40
b)	Where attached to branch waste pipes of less than 75 mm dia	40	40	75

NOTE — When connection is made through floor trap, no separate seals are required for individual fixtures.

4.5.3.6.2 Floor drains

All toilets/bathrooms in a building desirably should be provided with floor drains to facilitate cleaning.

4.5.3.6.2.1 Floor drains shall connect into a trap so constructed that it can be readily cleaned and of a size to serve efficiently the purpose for which it is intended. The trap shall be either accessible from the floor drain or by a separate cleanout within the drain.

4.5.3.6.2.2 Floor drain also receives, waste piping which does not connect to the sanitary system, known as indirect waste. This discharge from an indirect waste should be conveyed into a water supplied, trapped and vented floor drain.

Table 21 Building Drains and Sewers¹⁾
(Clause 4.5.3.5.1)

<i>Sl No.</i>	<i>Diameter of Pipe mm</i>	<i>Maximum Number of Drainage Fixture Units (DFU) that can be Connected to any Portion of the Building Drain or the Building Sewer Including Branches of the Building Drain²⁾, for Slope</i>			
		<i>1/200</i>	<i>1/100</i>	<i>1/50</i>	<i>1/25</i>
(1)	(2)	(3)	(4)	(5)	(6)
i)	32	—	—	1	1
ii)	40	—	—	3	3
iii)	50	—	—	21	26
iv)	65	—	—	24	31
v)	75	—	36	42	50
vi)	100	—	180	216	250
vii)	125	—	390	480	575
viii)	150	—	700	840	1 000
ix)	200	1 400	1 600	1 920	2 300
x)	250	2 500	2 900	3 300	4 200
xi)	300	3 900	4 600	5 600	6 700
xii)	375	7 000	8 300	10 000	12 000

¹⁾ Includes branches of the building sewer.

²⁾ The minimum size of any building drain serving a water closet shall be 75 mm.

Table 22 Different Diameter Pipes Giving Velocity and Corresponding Discharge at Minimum and Maximum Gradient
(Clauses 4.5.3.5.2.2, 4.5.3.5.2.4 and 4.5.3.5.2.5)

Sl No.	Diameter mm	Minimum Gradient (Velocity : 0.75 m/s)	Discharge at the Minimum Gradient m ³ /min	Maximum Gradient (Velocity : 2.4 m/s)	Discharge at the Maximum Gradient m ³ /min
(1)	(2)	(3)	(4)	(5)	(6)
i)	100	1 in 57	0.18	1 in 5.6	0.59
ii)	150	1 in 100	0.42	1 in 9.7	1.32
iii)	200	1 in 145	0.73	1 in 14	2.40
iv)	230	1 in 175	0.93	1 in 17	2.98
v)	250	1 in 195	1.10	1 in 19	3.60
vi)	300	1 in 250	1.70	1 in 24.5	5.30

4.5.3.6.2.3 Floor drain should be provided in mechanical equipment rooms, where pumps, boilers, water chillers, heat exchangers and other air conditioning equipment are periodically drained for maintenance and repair. Boiler requires drain at safety relief valve discharge.

4.5.3.6.2.4 Strategically floor drains are required to be located in buildings with wet fire protection sprinkler systems to drain water in case of activation of sprinkler heads.

4.5.3.6.2.5 The minimum diameter for floor drains outlets before connecting to floor trap is 75 mm.

4.5.3.6.3 Cleanouts

The cleanout provides access to horizontal and vertical lines and stacks to facilitate inspection and means to remove obstructions common to all piping systems,

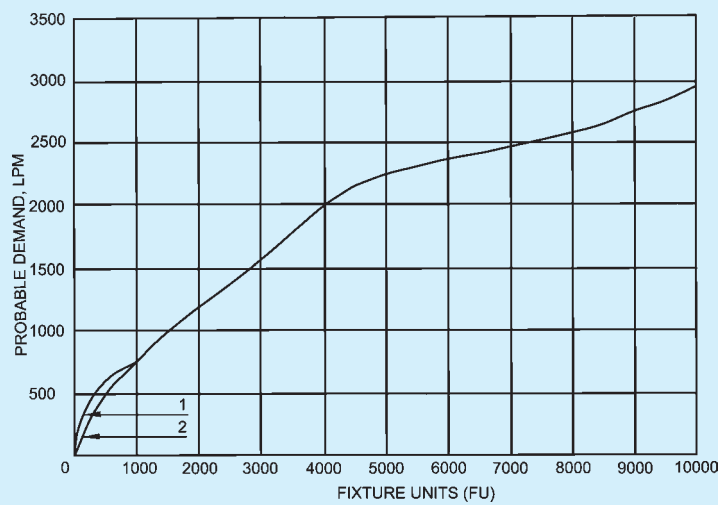

6A GRAPH FOR PROBABLE DEMAND UP TO 10 000FU

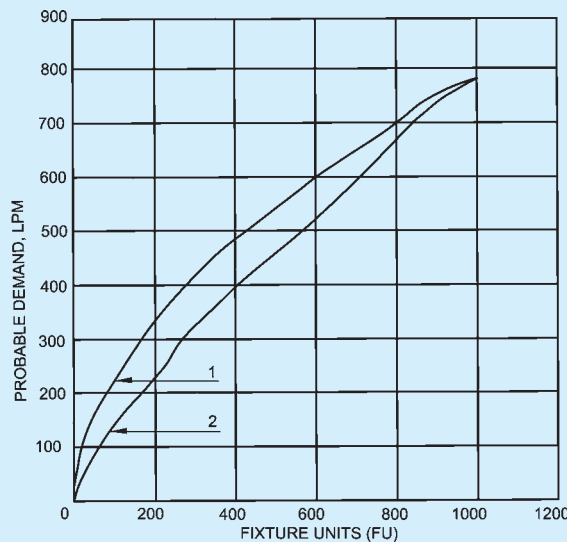

6B GRAPH FOR PROBABLE DEMAND UP TO 1 000FU

CURVE 1 — SYSTEM WITH FLUSH VALVES

CURVE 2 — SYSTEM WITH FLUSH TANKS

FIG. 6 GRAPH FOR PROBABLE DEMAND

such as solid objects, greasy wastes, hair and the like.

4.5.3.6.3.1 Cleanouts in general should be gas and water tight, provide quick and easy plug removal, allow ample space for rodding tools, have means of adjustments to finished floor level, be attractive and be designed to support whatever load is directed over them.

4.5.3.6.3.2 Waste lines are normally laid beneath the floor slab at a sufficient distance to provide adequate back-fill over the joints. Cleanouts are then brought up to floor level grade by pipe extension pieces.

4.5.3.6.3.3 The size of the cleanout within a building should be the same size as the piping up to 100 mm. For larger size piping 100 mm cleanouts are adequate for their intended purpose.

4.5.3.6.3.4 Cleanouts are suggested to be provided at the following locations:

- a) Inside the building at a point of exit. Use a wye branch or a trap.
- b) At every change of direction greater than 45°.
- c) At the base of all stacks.
- d) At the horizontal header, receiving vertical stacks and serving the purpose of offset header.

4.5.3.6.3.5 *Supports for drainage and sewerage pipes*

The supports for the above pipes and fittings shall be in accordance with manufacturer's recommendations and shall comply with the applicable standards.

4.5.4 *Indirect Wastes*

4.5.4.1 *General*

Waste, overflow and drain pipes from the following types of equipment shall not be connected into any drainage system directly to prevent backflow from the drainage system into the equipment/installation:

- a) Plumbing and kitchen appliances:
 - 1) Underground or overhead water tanks
 - 2) Drinking water fountains
 - 3) Dishwashing sinks and culinary sinks used for soaking and preparation of food
 - 4) Cooling counters for food and beverages
 - 5) Kitchen equipment for keeping food warm
 - 6) Pressure drainage connections from equipment
- b) Air conditioning, heating and other mechanical equipment:
 - 1) Air handling equipment
 - 2) Cooling tower and other equipment
 - 3) Condensate lines from equipment
 - 4) Storage tanks
 - 5) Condensate lines
 - 6) Boiler blow down lines
 - 7) Steam trap drain lines
- c) Laboratories and other areas:
 - 1) Water stills
 - 2) Waste from laboratory in specified sinks

- 3) Sterilizers and similar equipment

- 4) Water purification equipment

4.5.4.2 *Indirect waste receptors*

All plumbing fixtures or other receptors receiving the discharge of indirect waste pipes shall be of such shape and capacity as to prevent splashing or flooding and shall be located where they are readily accessible for inspection and cleaning.

4.5.4.3 *Pressure drainage connections*

Indirect waste connections shall be provided for drains, overflows or relief vents from the water supply system, and no piping or equipment carrying wastes or producing wastes or other discharges under pressure shall be directly connected to any part of the drainage system.

The above shall not apply to any approved sump pump or to any approved plumbing fixture discharging pressurized waste or device when the Authority has been satisfied that the drainage system has the capacity to carry the waste from the pressurized discharge.

An indirect waste is required for any type of fixture or equipment that may come in contact with the food. The purpose is to isolate the fixture or equipment from drainage system waste.

Indirect waste piping shall be a minimum of 25 mm in size, but not smaller than drain of the equipment or fixture. There is no limitation on the length of indirect waste piping.

4.5.5 *Special Wastes*

4.5.5.1 *General*

Wastes having characteristics which may be detrimental to the pipes in which it is disposed as well as to the persons handling it. Such wastes used in a building need to be specially identified and a suitable and safe method of its disposal installed to ensure that the piping system is not corroded nor the health and safety of the occupants is affected in any way.

Whenever the occupant or the user of any wastes is unaware of the dangers of the consequences of disposing the waste, he shall be made aware of the dangers of his action along with providing suitable warning and instruction for correct disposal be provided to him.

Piping system for all special wastes should be separate and independent for each type of waste and should not be connected to the building drainage system. Other applicable provisions for installation of soil and waste pipe system shall be however be followed.

4.5.5.2 *Laboratory wastes*

A study of the possible chemical and corrosive and toxic properties of wastes handled and disposed of in a laboratory need to be ascertained in advance. The relevant statutory rules and regulation regarding the method of disposal of strong and objectionable wastes shall be followed.

All sinks, receptacles, traps, pipes, fittings and joints shall be of materials resistant to the liquids disposed of

in the system.

In laboratories for educational, research and medical institutions, handling mildly corrosive and toxic wastes, they may be neutralized in chambers using appropriate neutralizing agents. The chamber shall be provided with chambers at inlet and outlet for collecting samples of the incoming and outgoing waste for monitoring its characteristics.

4.5.5.3 *Infected wastes*

Infected liquid wastes are generated in hospitals from patient excreta, operation theatres, laboratories testing samples of stools, urine, blood, flesh, etc, which shall not be disposed of into the drainage system. Such waste shall be collected separately and pre-treated, and sterilized, if required, before disposal into the building drainage system.

Soiled linen from infectious patients needs to be collected from the respective areas of the hospital in separate linen bins and pre-washed in dirty utility room in a sluice tub and sterilized in the laundry (sluice machine) before its regular washing in the hospital laundry. Liquid wastes from the washing operations shall be neutralized to prevent any cross contamination before discharge in the building's drainage system.

4.5.5.4 *Research laboratory wastes*

Research laboratories conducting research in all areas of science and technology, for example, chemical industry, pharmacy, metallurgy, bio-sciences, agriculture, atomic energy, medicine, etc, shall follow the established procedures laid down by statutory bodies to handle, treat and dispose wastes which are highly toxic, corrosive, infectious, inflammable, explosive and having bacterial cultures, complex organic and inorganic chemicals. Such wastes shall not be disposed of in a building drainage system or the city sewerage system unless they are pre-treated and meet the disposal criteria in accordance with the relevant rules/regulations.

It requires a liquid waste decontamination system which consists of at least one reactor or sterilizer plus a holding tank. An ideal system would consist of two or more sterilizers to provide redundancy with two or more tanks. There should be a sampling tank between this system and building drainage. The final reacted waste water should flow to ETP and not to STP.

4.5.6 *Grease Traps*

Oil and grease is found in wastes generated from kitchens in hotels, industrial canteens, restaurant, butcheries, some laboratories and manufacturing units having a high content of oil and greases in their final waste.

Waste exceeding temperature of 60°C should not be allowed in the grease trap. When so encountered, it may be allowed to cool in a holding chamber before entering the grease trap.

Oil and greases tend to solidify as they cool within the drainage system. The solidified matter clogs the drains

and the other matter in the waste stick to it due to the adhesion properties of the grease. Oil and greases are lighter than water and tend to float on the top of the waste water.

Grease traps shall be installed in building having the above types of wastes. In principle the grease laden water is allowed to retain in a grease trap which enables any solids to be settled or separated for manual disposal. The retention time allows the incoming waste to cool and allow the grease to solidify. The clear waste is then allowed to discharge into the building's drainage system.

4.5.7 *Oil Interceptors*

Oils and lubricants are found in wastes from vehicle service stations, workshops manufacturing units whose waste may contain high content of oils. Oils for example, petroleum, kerosene and diesel used as fuel, cooking, lubricant oils and similar liquids are lighter than water and thus float on water in a pipe line or in a chamber when stored. Such oils have a low ignition point and are prone to catch fire if exposed to any flame or a spark and may cause explosion inside or outside the drainage system. The flames from such a fire spread rapidly if not confined or prevented at the possible source. Lighter oils and lubricants are removed from the system by passing them through an oil interceptor/petrol gully. They are chambers in various compartments which allow the solids to settle and allow the oils to float to the top. The oil is then decanted in separate containers for disposal in an approved manner. The oil free waste collected from the bottom of the chamber is disposed of in the building drainage system.

4.5.8 *Radioactive Waste*

Scientific research institutions, hospital and many types of manufacturing processes use radioactive material in the form of radio-isotopes and other radioactive sources for their activities. Manufacture, sale, use and disposal of radioactive material is regulated by the statutory rules and regulation. Proposal for usage and disposal of radioactive materials shall be done in consultation with and prior permission of the Authority by the users of the materials. No radioactive material shall be disposed of in any building drainage system without the authorization of the Authority.

NOTE — All procedures followed and precautions taken shall be in accordance with AERB regulations, including regarding employing delay and decay tanks. Where applicable, the toilets may be designated as 'hot toilets' and should be clearly indicated. All drainage plumbing needs to be isolated and connected to delay and decay tanks (usually required for PET CT scan room, SPECT CT scan room and iodine therapy ward, and may be also required for cyclotron liquid waste).

4.5.9 *Special Situations of Waste Water Disposal*

Buildings may generate uncontaminated waste water from various sources continuously, intermittently or in large volumes for a short time for example, emptying any water tanks or pools, testing fire and water lines for flow conditions, etc. Connections from all such

sources shall be made to the building drainage system indirectly through a trap. It should be ensured in advance that the building drain or a sump with a pump has the capacity to receive to rate of flow. In case the capacity is less the rate of discharge from the appliances should be regulated to meet the capacity of the disposal. Under no circumstances shall any waste water described above shall be disposed of in any storm water drains.

4.5.10 Manholes

4.5.10.1 General

A manhole or inspection chamber shall be capable of sustaining the loads which may be imposed on it, exclude subsoil water and be water tight. The size of the chamber should be sufficient to permit ready access to the drain or sewer for inspection, cleaning and rodding and should have a removable cover of adequate strength, constructed of suitable and durable material. Where the depth of the chamber so requires, access rungs, step irons, ladders or other means should be provided to ensure safe access to the level of the drain or sewer. If the chamber contains an open channel, benching should be provided having a smooth finish and formed so as to allow the foul matter to flow towards the pipe and also ensure a safe foothold.

No manhole or inspection chamber shall be permitted inside a building or in any passage therein. The minimum depth of the manhole shall not be less than 800 mm to facilitate gully trap connection. Further, ventilating covers shall not be used for domestic drains. At every change of alignment, gradient or diameter of a drain, there shall be a manhole or inspection chamber. Bends and junctions in the drains shall be grouped together in manholes as far as possible.

Alternative materials of manholes using RCC rings and PVC in sewer lines are being used in some sites. These may be considered subject to ensuring their proper design, keeping in view the lateral and vertical loads at the place of installation.

The holes over the surfaces of covers/gratings of various manholes, gullies and other chambers/drains shall comply with the requirements given in 13 of Part 3 'Development Control Rules and General Building Requirements' of the Code.

4.5.10.2 Spacing of manholes

The spacing of manholes for a given pipe size should be as follows:

<i>Sl No.</i>	<i>Pipe Diameter</i> mm	<i>Spacing of Manhole</i> m
i)	Up to 300	45
ii)	301 to 500	75
iii)	501 to 900	90
iv)	Beyond 900	Spacing shall depend upon local condition and shall be gotten approved by the Authority

Where the diameter of a drain is increased, the crown of the pipes shall be fixed at the same level and the necessary slope given in the invert of the manhole chamber. In exceptional cases and where unavoidable, the crown of the branch sewer may be fixed at a lower level, but in such cases the peak flow level of the two sewers shall be kept the same.

4.5.10.3 Size of manhole

The manhole or chamber shall be of such size as will allow necessary examination or clearance of drains. The size of shall be adjusted to take into account any increase in the number of entries into the chamber.

4.5.10.3.1 Manholes may be rectangular, arch or circular type. The minimum internal size of manholes, chambers (between faces of masonry) shall be as follows:

- a) *Rectangular manholes:*
 - 1) For depths less than 0.90 m 900 mm × 800 mm
 - 2) For depths from 0.90 m and up to 2.5 m 1 200 mm × 900 mm

NOTE — For depths upto 0.60 m, 600 mm × 600 mm manhole may be used.

- b) *Arch type manholes:*
 - For depths of 2.5 m and above 1 400 mm × 900 mm

NOTE — The width of manhole chamber shall be suitably increased more than 900 mm on bends, junctions or pipes with diameter greater than 450 mm so that benching width in either side of channel is minimum 200 mm.

- c) *Circular manholes:*
 - 1) For depths above 0.90 m and up to 1.65 m 900 mm diameter
 - 2) For depths above 1.65 m and up to 2.30 m 1 200 mm diameter
 - 3) For depths above 2.30 m and up to 9.00 m 1 500 mm diameter
 - 4) For depths above 9.00 m and up to 14.00 m 1 800 mm diameter

NOTES

- 1 In adopting the above sizes of chambers, it should be ensured that these sizes accord with full or half bricks with standard thickness of mortar joints so as to avoid wasteful cutting of bricks.
- 2 The sizes of the chambers/manhole may be adjusted to suit the availability of local building materials, economics of construction and to meet local authority approval.
- 3 The access shaft shall be corbelled inwards on three sides at the top to reduce its size to that of the cover frame to be fitted or alternatively the access shaft shall be covered over by a reinforced concrete slab of suitable dimensions with an opening for manhole cover and frame.
- 4 The minimum sewer pipe diameter is 200 mm based on good practice [9-2(12)].

4.5.10.4 Construction

4.5.10.4.1 Excavation

The manhole shall be excavated true to dimensions and

levels as shown on the plan. The excavation of deep manholes shall be accompanied with safety measures like timbering, staging, etc. In areas where necessary, appropriate measures for dewatering should be made.

4.5.10.4.2 Bed concrete

The manhole shall be built on a bed of concrete 1:4:8 (1 cement : 4 coarse sand : 8 graded stone aggregate 40 mm nominal size). The thickness of bed concrete shall be at least 150 mm for manholes up to 0.9 m in depth, at least 200 mm for manholes from 0.90 m up to 2.5 m in depth and at least 300 mm for manholes of greater depth, unless the structural design demands higher thickness.

This thickness may be verified considering the weight of wall, cover, the wheel loads, impact of traffic which are transmitted through cover and the shaft walls and for water pressure, if any. In case of weak soil, special foundation as suitable shall be provided

4.5.10.4.3 Brickwork

The thickness of walls shall be designed depending upon its shape and taking into account all loads coming over it, including earth pressure and water pressure.

Generally, the brickwork shall be with first class bricks in cement mortar 1: 5 (1 cement : 5 coarse sand). All brickwork in manhole chambers and shafts shall be carefully built in English Bond, the jointing faces of each brick being well ‘buttered’ with cement mortar

before laying, so as to ensure a full joint. The construction of walls in brickwork shall be done in accordance with good practice [9-2(13)].

For various depths the recommended thickness of wall may be as follows:

Depth of the chamber thickness of wall

- a) Up to 2.25 m : 200 mm (one brick length)
- b) From 2.25 m up to 3.0 m : 300 mm (one and half brick length)
- c) From 3.00 m up to 5.0 m : 400 mm (two brick length)
- d) From 5.00 m up to 9.0 m : 500 mm (two and half brick length)
- e) Above 9.00 m : 600 mm (three brick length)

The actual thickness in any case shall be calculated on the basis of engineering design. Typical sections of the manholes are illustrated in Figs. 7, 8 and 9.

NOTES

- 1 Rich mix of cement mortar, not weaker than 1:3, should be used in brick masonry, where subsoil water conditions are encountered.
- 2 For arched type of manholes, the brick masonry in arches and arching over pipes shall be in cement mortar 1:3.

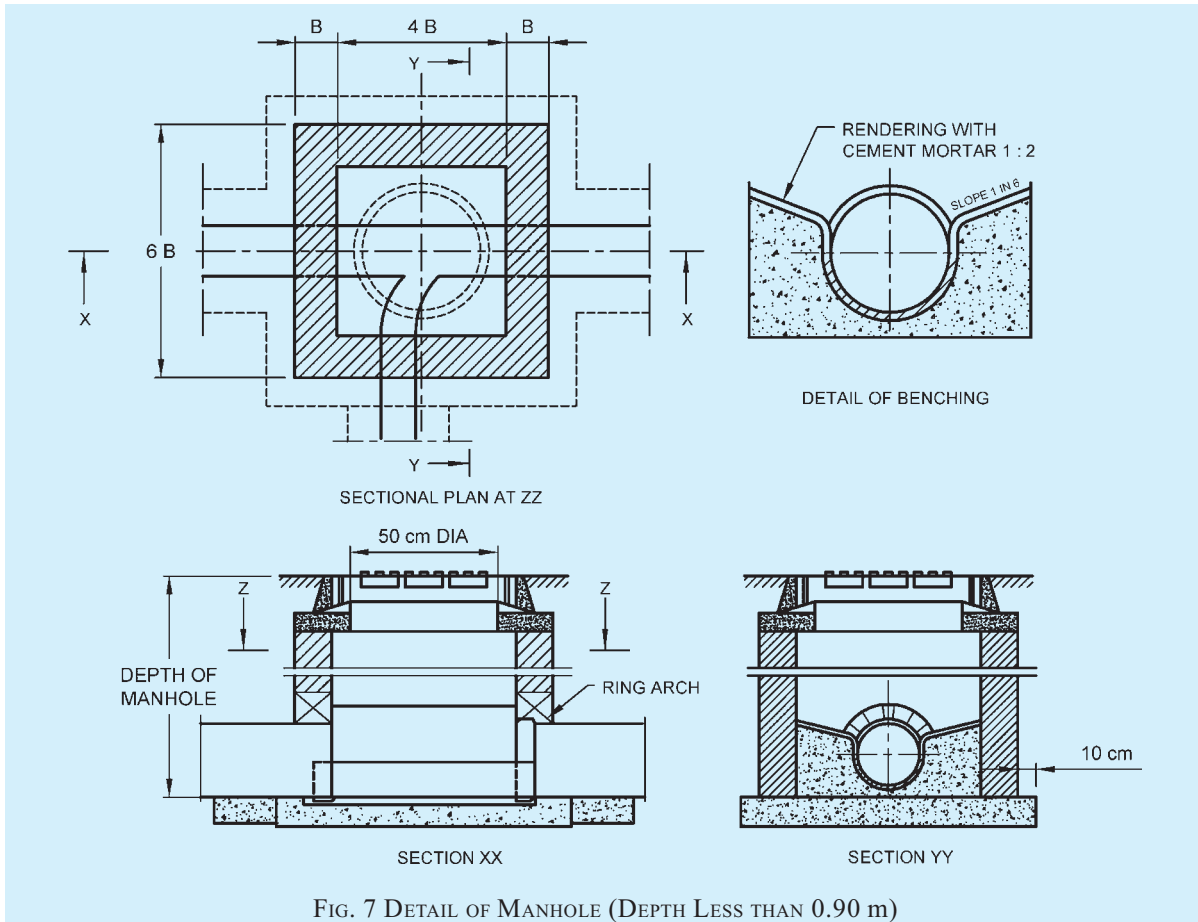

FIG. 7 DETAIL OF MANHOLE (DEPTH LESS THAN 0.90 m)

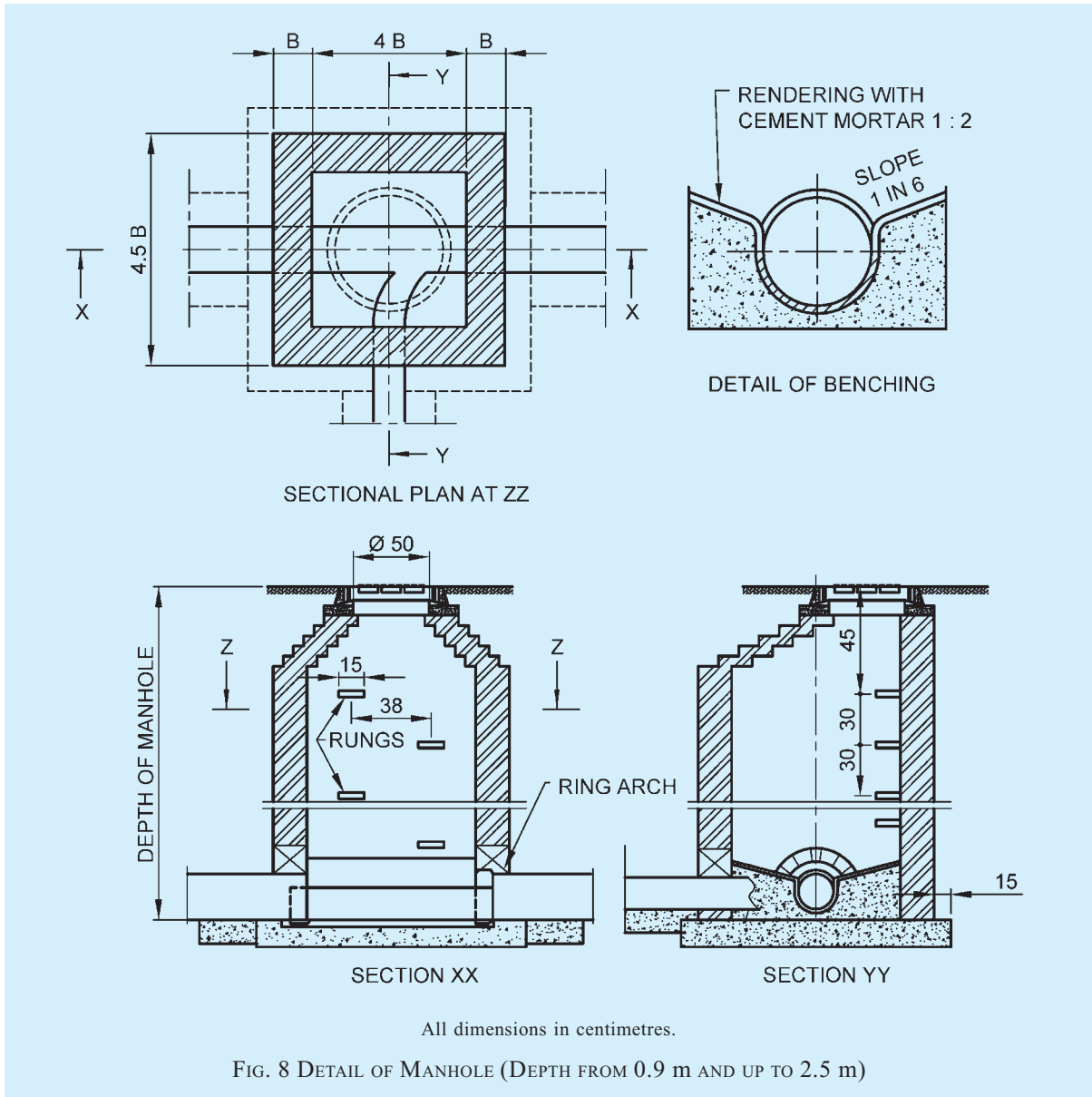

FIG. 8 DETAIL OF MANHOLE (DEPTH FROM 0.9 m AND UP TO 2.5 m)

4.5.10.4.4 Plastering

The wall shall be plastered (15 mm, minimum) both inside and outside within cement mortar 1:3 and finished smooth with a coat of neat cement. Where subsoil water conditions exist, a richer mix may be used and it shall further be waterproofed with addition of approved waterproofing compound in a quantity as per manufacturer specifications.

All manholes shall be so constructed as to be water-tight under test.

All angles shall be rounded to 75 mm radius and all rendered internal surface shall have hard impervious finish obtained using a steel trowel.

4.5.10.4.5 Channels and benching

These shall be semi-circular in the bottom half and of

diameter equal to that of the sewer. Above the horizontal diameter, the sides shall be extended vertically 50 mm above the crown of sewer pipe and the top edge shall be suitably rounded off. The branch channels shall also be similarly constructed with respect to the benching, but at their junction with the main channel an appropriate fall, if required suitably rounded off in the direction of flow in the main channel shall be given.

The channel/drain and benching at the bottom of the chamber shall be done in cement concrete 1:2:4 and subsequently plastered with cement mortar of 1:2 proportion or weaker cement mortar with a suitable waterproofing compound and finished smooth, to the grade (where required). The benching at the sides shall be carried up in such a manner as to provide no lodgment for any splashing in case of accidental flooding of the chamber.

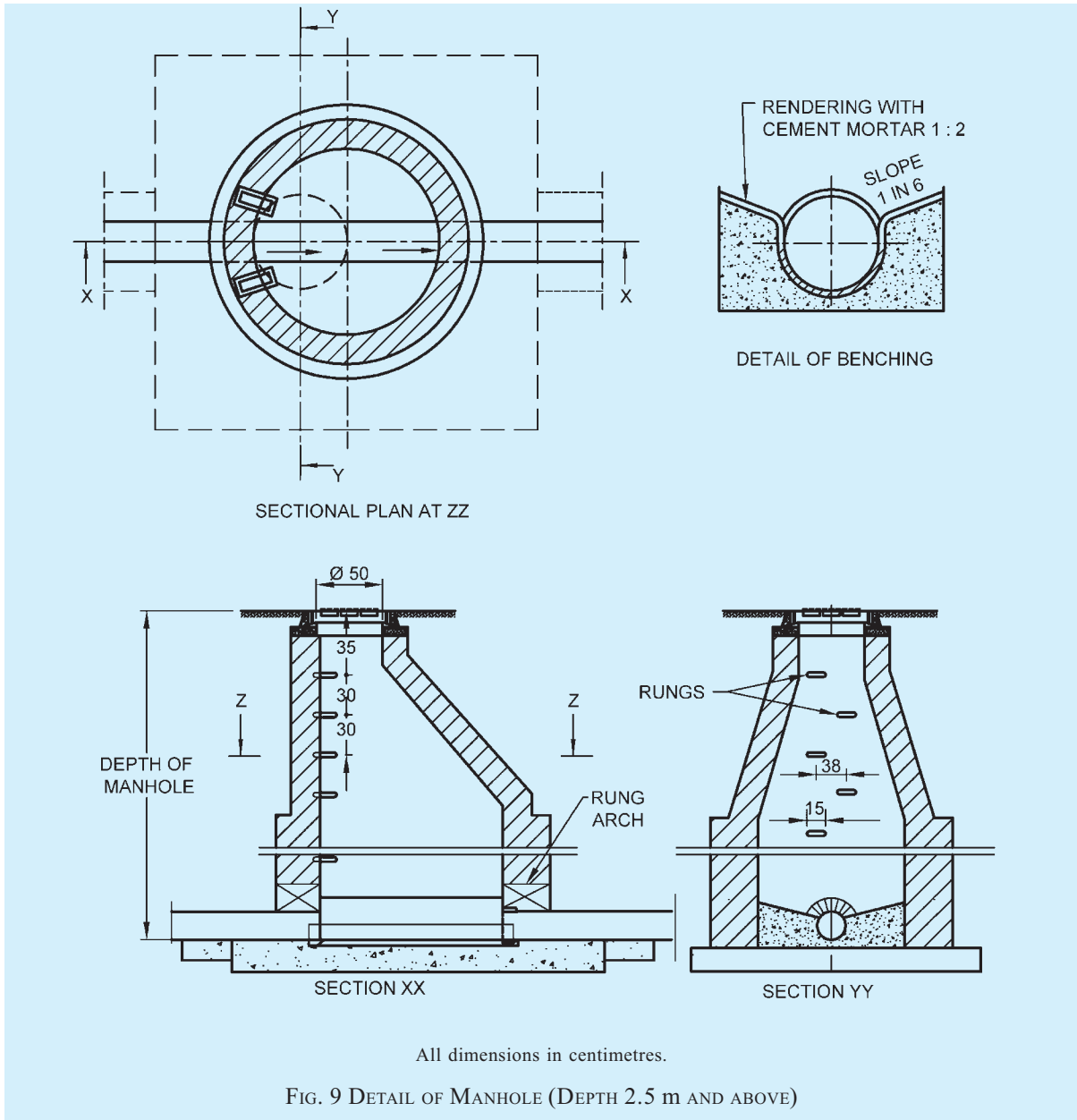

Channels shall be rendered smooth and benchings shall have slopes towards the channel.

4.5.10.4.6 Rungs

Rungs shall be provided in all manholes over 0.8 m in depth and shall be of cast iron, or PVC encapsulated or composite non-corrosive materials, and of suitable dimensions, conforming to accepted standards [9-2(14)]. These rungs may be set staggered in two vertical rungs which may be 300 mm apart horizontally as well as vertically and shall project a minimum of 100 mm beyond the finished surface if the manhole wall. The top rung shall be 450 mm below the manhole cover and the lowest not more than 300 mm above the benching.

4.5.10.4.7 Manhole covers and frames

The size of manhole covers shall be such that there shall be a clear opening of at least 500 mm in diameter for manholes exceeding 0.90 m in depth. The manhole covers and frames used shall conform to accepted standards [9-2(15)].

The frame of manhole shall be firmly embedded to concrete alignment and level in plain concrete on the top of masonry.

4.5.10.5 Drop manhole

Where it is uneconomic or impracticable to arrange the connection within 600 mm height above the invert of the manholes, the connection shall be made by constructing a vertical shaft outside the manhole

chamber, as shown in Fig. 10. If the difference in level between the incoming drain and the sewer does not exceed 600 mm, and there is sufficient room in the manhole, the connecting pipe may be directly brought through the manhole wall and the fall accommodated

by constructing a ramp in the benching of the manhole.

For detailed information regarding manholes in sewerage system, reference may be made to good practice [9-2(16)].

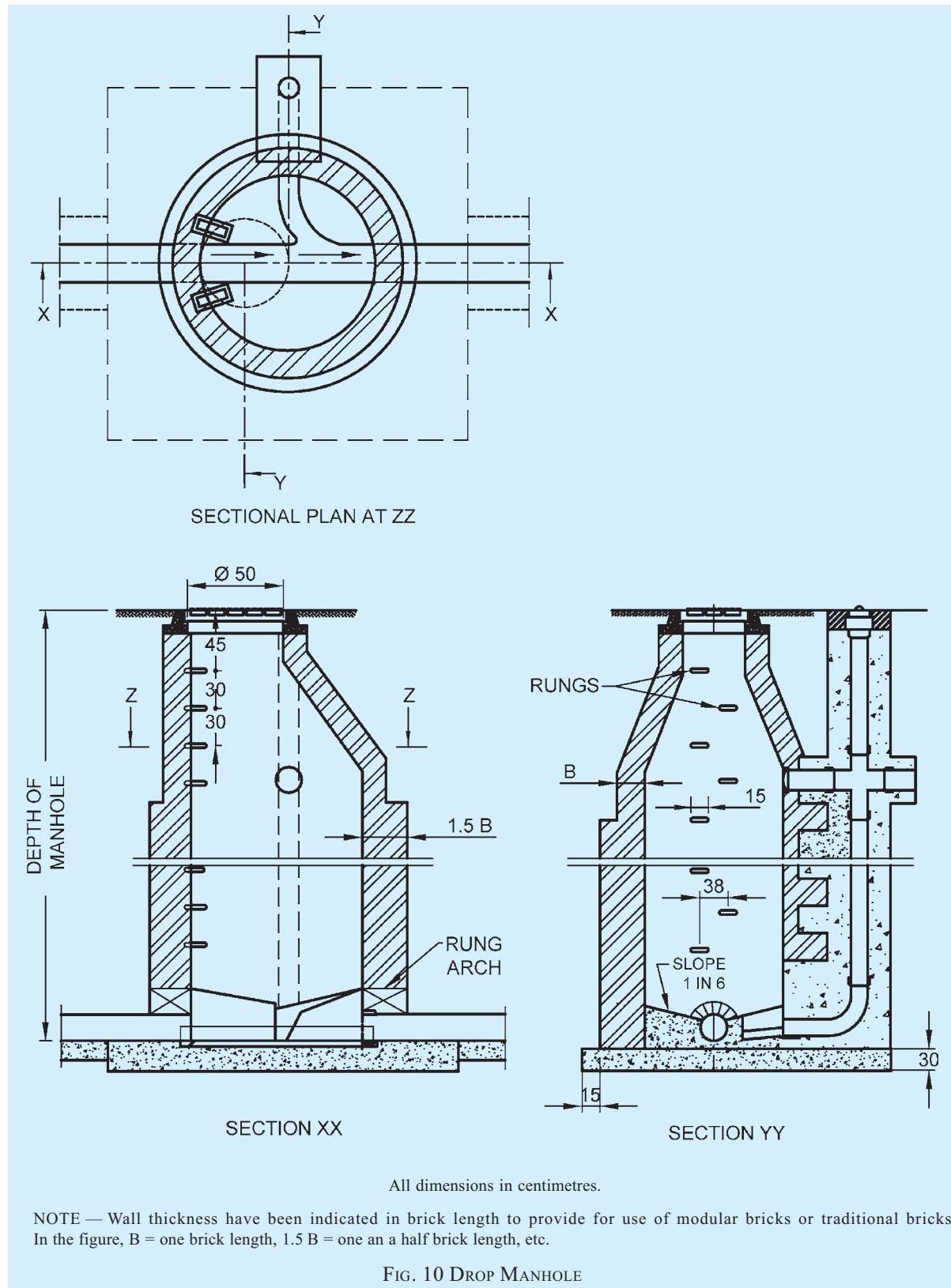

4.5.10.6 Manhole covers and recommended locations

Manhole covers were traditionally and presently manufactured from concrete, steel fibre reinforced concrete, cast iron and ductile iron or PVC materials and these materials are used based on the load carrying capacity and for the following type of applications:

- a) Inspection chambers for sewerage;
- b) Underground electrical cabling;
- c) Telecom cabling;
- d) Water, gas and petroleum installations; and
- e) Beautification of gardens and landscapes.

Recommended locations conforming to load capacity shall be as per accepted standard [9-2(15)].

4.5.11 Storm Water Drainage

4.5.11.1 General

The object of storm water drainage is to collect and carry, the rainwater collected within the premises of the building, for suitable disposal.

4.5.11.2 Design factors

Estimate of the quantity that reaches the storm water drain (runoff) depends on the following factors:

- a) Type of soil and its absorption capacity determined by its soil group.
- b) Ground slope and the time in which the area is drained.
- c) Intensity of the rainfall for a design period.
- d) Duration of the rain/storm.

The runoff reaching the sewer may be given by the expression:

$$Q = 10 C.i.A$$

where

Q = runoff, m³/h;

C = coefficient of runoff;

i = intensity of rainfall, mm/h; and

A = area of the drainage district, hectares.

Coefficient of runoff for various surfaces may be taken as:

Type of Surface	Coefficient of Runoff
Concrete roof area	0.9
Paved podium areas and asphalted roads	0.8
Unpaved ground	0.3
Lawns and parks	0.15

4.5.11.2.1 Imperviousness

The soil conditions and the ground slope determine the impermeability factor. Impermeability factor is the

proportion of the total rainfall received on the surface which will be discharging into a storm water drain after allowing for initial abstraction (in local pond and lakes), ground absorption by evaporation, vegetation and other losses. The net flow reaching the storm water drain is called runoff.

The percentage of imperviousness of the drainage area may be obtained from available data for a particular area. In the absence of such data, the following figures may serve as a guide:

Type of Area	Imperviousness Factor Percent
Commercial and industrial areas	70 - 90
Residential areas (high density)	60 - 75
Residential areas (low density)	35 - 60
Parks and underdeveloped areas	10 - 20

4.5.11.2.2 Terrain modelling

Areas planned for urbanization from agricultural land, forest or low grade land for example, low lying areas prone to flooding, marshy or abandoned quarries, etc, need detailed and careful consideration with respect to its drainage. A detailed contour survey shall be carried out not only with respect to the site but also the surrounding areas to verify the quantity/area contributing runoff, presence of any low lying and natural water body acting as holding pond or any natural drain passing through the area and beyond whose filling up or diversion may cause water logging problem on the site or to the surrounding areas.

The planning of the area should ensure that,

- a) all areas become self draining by gravity with respect to the high flood level of the area or the drainage channels passing, whichever is higher;
- b) as far as possible, natural drainage pattern with respect to the whole area be maintained except when low lying areas need to be filled up for grading purposes;
- c) the drainage in the area shall be planned in accordance with the natural slopes; and
- d) levels of the main highway or road connecting to the property shall be determined to ensure proper drainage and protection of the site.

The formation levels of the entire area shall be prepared to determine proposed formation levels by preparing a terrain model which will show the proposed site contours, ground and road levels and connections to all services including storm water disposal system.

4.5.11.2.3 Rainfall intensity

The intensity of rainfall is the amount of rain falling in

unit time and is expressed in centimetre or millimetre per hour. For design purposes, the mean rainfall intensity is collected for 25 years.

4.5.11.2.4 *Design frequency*

Storm water drainage system for an urbanized area is planned on the basis of the design frequency of the storm which shall be determined by the designer. Frequency is the period in which the selected design intensity recurs in a given period of time in years.

NOTE — The rainfall intensity varies with the period, which includes good, bad and average years of rainfall. Meteorological department has long term data regarding the rainfall and have graphs for different periods and the designers are advised to consult the department before designing any scheme.

4.5.11.2.5 *Time of concentration*

Time of concentration is the time required for the rainwater to flow to reach the farthest point of the drainage system or the outfall under consideration. Time of concentration is equal to the inlet time plus the time required for the flow to reach the main or branch drain. The inlet time is the time dependent on the distance of the farthest point in the drainage area to the inlet of the manhole and the surface slopes, etc, and will vary between 5 min and 30 min.

In highly developed sections for example with impervious surfaces it may be as low as 3 min or lower (with good slopes) as in building terraces and paved areas. Correspondingly the design intensity for the drainage for such areas will be much higher. Rainwater pipes have to be designed for an intensity for a very low time of concentration.

4.5.11.2.6 *Natural infiltration*

In planning any area with buildings, layout with paved and non-permeable surfaces, care should be taken to allow maximum discharge of the rainwater to flow directly or indirectly to permeate into the ground for enabling the ground water to be recharged. Some of the techniques which allow infiltration that may be considered are:

- a) Use of brick paved open jointed storm water drains.
- b) Providing bore holes in the storm water drains.
- c) Using paving tiles with open joints which enable water to percolates as it flows on it.

4.5.11.3 *Combined system*

A combined system of drainage is one which carries the sewerage as well as the runoff from the storm water drainage. Relevant applicable statutory rules/regulations may not allow such system in new areas and the sewerage and the storm water drainage have to be separate and independent of each other. Such systems

are however existing in many old cities and the storm water may have to be discharged into the combined drainage system.

Where levels do not permit for connection to a public storm water drain, storm water from courtyards of buildings may be connected to the public sewer, provided it is designed to or has the capacity to convey combined discharge. In such cases, the surface water shall be admitted to the soil sewer through trapped gullies in order to prevent the escape of foul air.

4.5.11.4 *Discharging into a watercourse*

It may often be convenient to discharge surface water to a nearby stream or a watercourse. The invert level of the outfall shall be about the same as the normal water level in the watercourse or ideally should be above the highest flood level of the watercourse. The out-fall shall be protected against floating debris by a screen.

4.5.11.5 *Discharge to a public storm water drain*

Where it is necessary to connect the discharge rainwater into a public storm water drain, such drains shall be designed for the intensity of rain based on local conditions, but in no case shall they be designed for intensity of rainfall of less than 50 mm/h. Rainwater from each building plot shall be connected to the storm water drainage through a separate pipe or an open public drain directly. No trap shall be installed before the connection.

4.5.11.6 *Rainwater pipes for roof drainage*

4.5.11.6.1 The roofs of a building shall be so constructed or framed as to permit effectual drainage of the rainwater therefrom by means of a sufficient number of rainwater pipes of adequate size so arranged, jointed and fixed as to ensure that the rainwater is carried away from the building without causing dampness in any part of the walls or foundations of the building or those of an adjacent building.

4.5.11.6.2 The rainwater pipes shall be fixed to the outside of the external walls of the building or in recesses or chases cut or formed in such external wall or in such other manner as may be approved by the Authority.

4.5.11.6.3 Rainwater pipes conveying rainwater shall discharge directly or by means of a channel into or over an inlet to a surface drain or shall discharge freely in a compound, drained to surface drain but in no case shall it discharge directly into any closed drain.

4.5.11.6.4 Whenever it is not possible to discharge a rainwater pipe into or over an inlet to a surface drain or in a compound or in a street drain within 30 m from the boundary of the premises, such rainwater pipe shall

discharge into a gully trap which shall be connected with the street drain for storm water and such a gully-trap shall have a screen and a silt catcher incorporated in its design.

4.5.11.6.5 If such streets drain is not available within 30 m of the boundary of the premises, a rainwater pipe may discharge directly into the kerb drain and shall be taken through a pipe outlet across the foot path, if any, without obstructing the path.

4.5.11.6.6 A rainwater pipe shall not discharge into or connect with any soil pipe or its vent pipe or any waste pipe or its vent pipe nor shall it discharge into a sewer unless specifically permitted to do so by the Authority, in which case such discharge into a sewer shall be intercepted by means of a gully trap.

4.5.11.6.7 Rainwater pipes shall be constructed of cast iron, PVC, asbestos cement, galvanized sheet or other equally suitable material and shall be securely fixed.

4.5.11.6.8 The factors that decide the quantity of rainwater entering are:

- a) Intensity of rainfall, and
- b) Time of concentration selected for rainwater pipe.

A bell mouth inlet at the roof surface is found to give better drainage effect, provided proper slopes are given to the roof surface. The spacing of rainwater pipes depends on the locations available for the down takes and the area which each pipe serves. The spacing will also be determined by the amount of slopes that can be given to the roof. The recommended slopes for the flat roofs with smooth finish would be 1:150 to 1:133, with rough stone/tiles 1:100 and for gravel set in cement or losely packed concrete finish 1:75 to 1:66. The effective strainer area should preferably be 1.5 to 2 times the area of pipe to which it connects to considerably enhance the capacity of rainwater pipes.

The rainwater pipes of cast iron (coefficient of roughness 0.013) shall normally be sized on the basis of roof areas according to Table 23. The vertical down take rainwater pipes, having a bell mouth inlet on the roof surface with effective cross-sectional area of grating 1.5 to 2 times the rainwater pipe area, may be designed by considering the outlet pipe as weir.

The roof area (RA) for drainage may be worked out by using:

$$RA = 0.084 \times d^{5/2}/I$$

where

RA = roof area, m²;

d = pipe diameter, mm; and

I = intensity of rainfall, mm/h.

4.5.11.6.9 The storm water may be led off in a suitable open drain to a watercourse. The open drain, if not a *Pucca* masonry throughout, shall be so at least where there is either a change in direction or gradient.

4.5.12 Rainwater Harvesting

4.5.12.1 General

To supplement the ever growing shortage of protected, pure and safe water supply for human consumption, rainwater is an ideal source which can be conserved and used in a useful manner by the people. The amount of rainfall available varies from region to region. Each area has to develop its own method and system to conserve, store and use it to suit its requirement and local conditions. There are several methods by which rainwater can be stored, used and conserved. Each system depends on the amount of precipitation, the period in which the rainfall occurs in a year and the physical infrastructure, for example space available to store the water, etc.

There are several techniques available for catching and storing the rainwater. Most of the techniques are applicable for large open areas, farms, sloping grounds,

Table 23 Sizing of Rainwater Pipes for Roof Drainage in mm/h
(Clause 4.5.11.6.8)

Sl No.	Dia of Pipe mm	Roof Area, in m ² for Average Rate of Rainfall in mm/h					
		50	75	100	125	150	200
(1)	(2)	(3)	(3)	(3)	(3)	(3)	(3)
i)	50	29.70	19.80	14.85	11.88	9.90	7.42
ii)	65	57.23	38.15	28.61	22.89	19.08	14.31
iii)	75	81.84	54.56	40.92	32.74	27.28	20.46
iv)	100	168.00	112.00	84.00	67.20	56.00	42.00
v)	125	293.48	195.66	146.74	117.39	97.83	73.37
vi)	150	462.95	308.64	231.48	185.18	154.32	115.74

NOTE — For rainwater pipes of other materials, the roof areas shall be multiplied by (0.013/coefficient of roughness of surface of that material). For example, for rainwater pipes of PVC (coefficient of roughness = 0.009), the above values of roof area shall be multiplied by 0.013/0.009 = 1.44.

etc, with a low population base. Two major systems that are ideal for urban and semi-urban developed areas are:

- a) Artificial ground water recharge, and
- b) Roof top rainwater harvesting.

NOTE — Type and number of recharge pits and roof top rainwater harvesting capacity shall be provided as per the local/state bye-laws.

4.5.12.2 Artificial ground water recharge

With increase in the impermeable surfaces in modern built up areas, there is gross reduction in the original catchment area. This prevents the natural percolation that would have recharged the area in the normal course if the ground was in its natural condition, for example a farm, open ground, forest, etc. This results in a large quantity of water, normally percolating into the ground, running off to the natural drains and into the rivers, causing increased runoff and flooding of downstream areas.

It is therefore essential to catch the runoff and use it for augmentation of ground water reservoir by modifying the natural movement of surface water by recharging it by artificial means, for example construction of recharge structures (*see* Fig. 11). The main objectives achieved may be:

- a) Enhancement of sustainable yield in areas where over development and depletion of the aquifers.
- b) Conservation and storage of excess surface water in the aquifers.
- c) Improve the quality of the existing ground water through dilution.
- d) Remove bacteriological and suspended impurities during the surface water transition within the subsoil.
- e) Maintain the natural balance of the ground water and its usage as the rainwater is a renewable supply source. A well managed and controlled tapping of the aquifers will provide constant, dependable and safe water supply.

In planning and designing the ground water recharge structures, following should be taken into consideration:

- 1) Annual rainfall (for estimating approximately rainwater recharge per year).
- 2) Peak intensity and duration of each storm.
- 3) Type of soil and subsoil conditions and their permeability factor.
- 4) Ground slopes and run off which cannot be caught.

- 5) Location of recharge structures and its overflow outfall.
- 6) Rainwater measuring devices for finding the flow of water in the system.

For artificial recharge to ground water code for guidelines for artificial recharge to ground water [9-2(17)] may be referred.

NOTE — Rainwater harvesting with underground recharging will depend from region to region as per the climatic, topography, soil conditions and data about intensity of rainfall and retention time for calculating the capacity of recharge wells to be obtained from reference documents from the Authority.

4.5.12.3 Roof top rainwater harvesting

4.5.12.3.1 Harvesting in regular rainfall areas

In areas having rainfall over a large period in a year, for example in hilly areas, coastal regions, etc constant and regular rainfall can be usefully harvested and stored in suitable water tanks. Water shall be collected through roof gutters and down take pipes. Provision should be made to divert the 1st rainfall after a dry spell so that ant dust, soot and leaves, etc, are drained away before the water is collected into the water tank. The capacity of the water tank should be enough for storing water required for consumption between two dry spells. The water tank shall be located in a well protected area and shall not be exposed to any hazards of water contamination from any other sources. The water shall be chlorinated using chlorine tablets or solution to maintain a residual chlorine of approximately 1 mg/l. The tank shall have an overflow leading to natural water courses or to any additional tanks (*see* Table 24).

4.5.12.3.2 Harvesting in limited rainfall areas

In areas with the rainfall limited during the monsoon period (usually from 15-90 days), roof top rainwater can be stored and used for non-potable purposes, after proper treatment, in the premises itself as mentioned above; excess water, if any, is best used for recharging the ground water. For individual properties and plots the roof top rainwater can be diverted to underground or above ground water storage tank(s), pretreated, stored and used for non-potable purposes. Excess water, if any, may be discharged to existing open or abandoned tube wells. In a well-planned building complex, a system should be laid out so that the runoff is collected in underground or above ground water storage tank(s), pretreated, stored, and used for non-potable purposes. Excess water, if any, shall be discharged in bore-wells as per designs specified by the Central Ground Water Board, Government of India.

For roof top rainwater harvesting, reference may be made to good practice [9-2(18)].

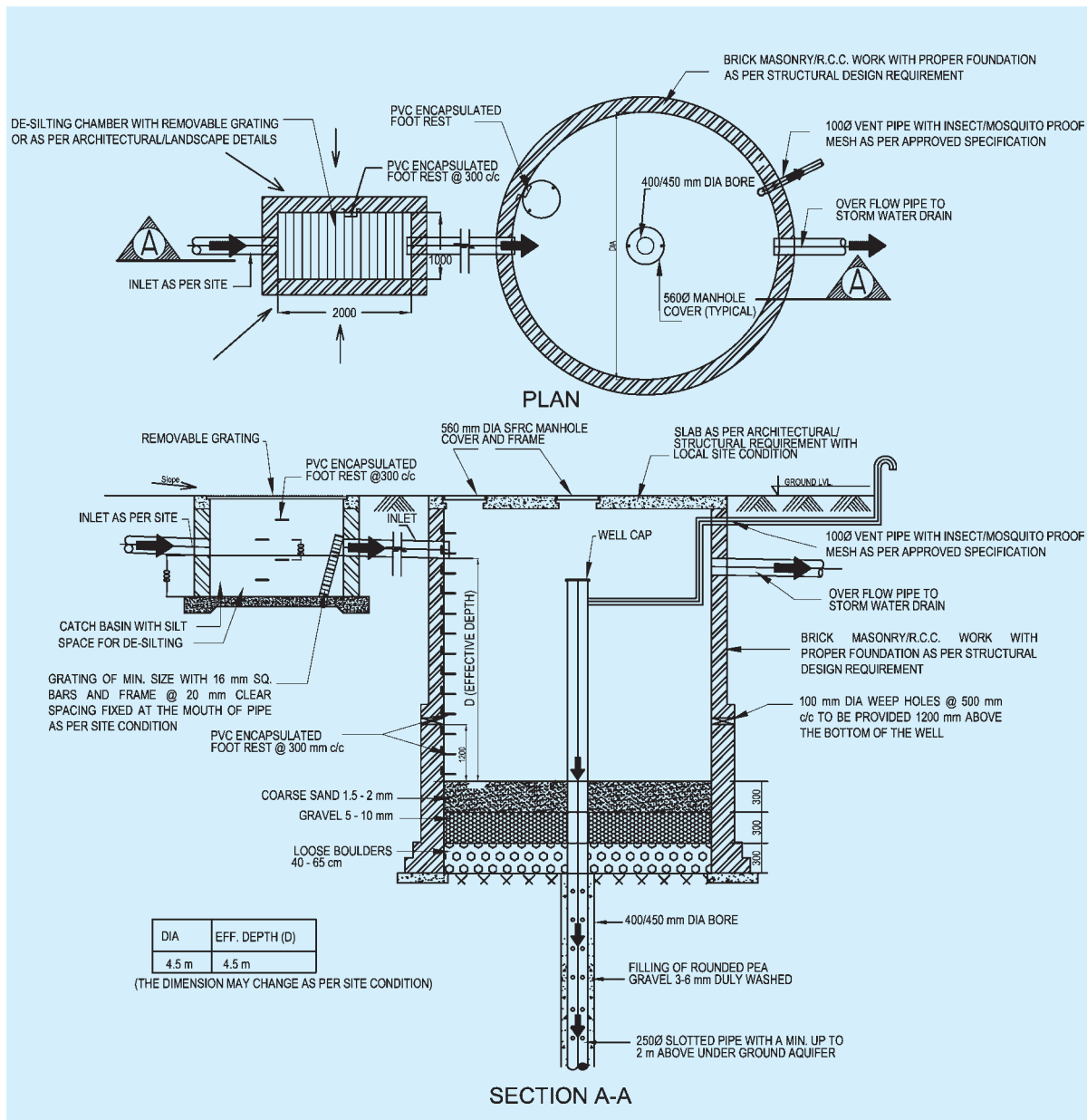

All dimensions in millimetres unless specified.

NOTE — Depending on site soil condition and keeping the above plumbing details and dimensions in view, the detailed structural/shop drawing to be prepared, before executing the work.

FIG. 11 ARTIFICIAL GROUND WATER RECHARGE STRUCTURE

4.5.12.4 Care to be taken in rainwater harvesting

Water conservation technique discussed above shall be constructed with due care taking following precautions:

- a) No sewage or waste water should be admitted into the system.
- b) No waste water from areas likely to have oil, grease or other pollutants should be connected to the system.
- c) Each structure/well shall have an inlet

chamber with a silt trap to prevent any silt from finding its way into the subsoil water.

- d) The wells should be terminated at least 5 m above the natural static subsoil water at its highest level so that the incoming flow passes through the natural ground condition and prevent contamination hazards.
- e) No recharge structure or a well shall be used for drawing water for any purpose.

4.5.12.5 Siphonic drainage system

It is an installation generally used for special situations such as roofs with large spans for structures like hangars, airport terminals, stadia and industrial sheds, where the number of down pipes has to be limited. These are designed for full flow of pipes and the roof outlets are different from conventional ones.

Siphonic roof drainage systems are engineered on the concept of a full bore (a fill rate of 100 percent). This implies that rainwater flows at high speed through small diameter pipe work, at normally zero gradient.

This siphonic effect is created by the (kinetic) energy derived from the hydraulic head, caused by the difference in height between the roof outlet and the discharge point in a building. Specialist roof outlets prevent air being sucked into the system.

The engineering principle of siphonic roof drainage design is based on the Bernoulli's energy equation for a steady flow of an incompressible fluid with constant density. In order to balance the equation, and to guarantee the required siphonic effect according to the rainfall intensity, the ideal pipe dimensions per flow path need to be determined.

In case of syphon system, the outlets of drainage system prevent vortex formation, thereby preventing air from entering the pipeline ensuring the entire system is running at full flow (see Fig. 12). It uses design that complies with Bernoulli's principle where equal energy is created under positive and negative pressure.

4.5.12.6 Rainwater harvesting for plotted/group housing developments

The rainwater harvesting methods adopted for plotted and group housing are through collection of rooftop rainwater and surface runoff harvesting.

A network of storm water drains in the entire residential area is used for harvesting rooftop rainwater and surface runoff. Appropriate number of recharge wells measuring 1 m × 1 m × 2 m may be constructed in the storm water drain for facilitating groundwater recharge. The quality of runoff, which passes through the borewell installed inside the recharge well, is ensured through a filter bed of pebbles (see Fig. 11).

4.5.12.7 Other methods of rainwater harvesting

- a) *Creation of artificial reservoirs/lakes for utilization of available storm water* — This shall be based on estimation of amount of runoff volume based on rainfall data (for a period of 10 years) considering the percolation and evaporation losses and efforts to be made to collect all available runoff for proper utilization.
- b) *Water balancing methods* — This refers to optimum utilization of available water from different sources, namely ground water, recycled waste water, storm water and municipal supply and its adoption would ensure that there is no wastage of water.

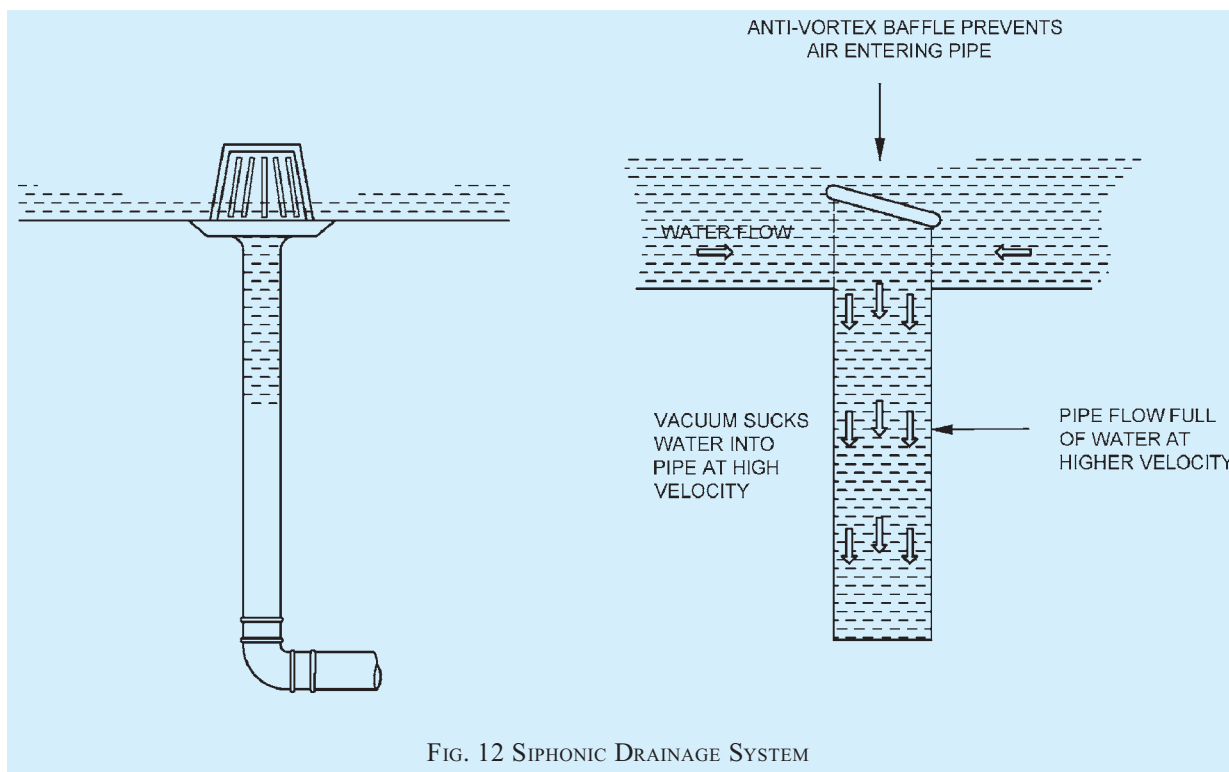

FIG. 12 SIPHONIC DRAINAGE SYSTEM

Table 24 Rainwater Available from Roof Top Harvesting
(Clause 4.5.12.3.1)

Rain fall mm	100	200	300	400	500	600	700	800	900	1 000	1 100	1 200	1 300	1 400	1 500	1 600	1 700	1 800	1 900	2 000	
Roof Top Area m ²	Harvested Water from Roof Tops, m ³ (80 percent of gross precipitation)																				
(1)	(2)	(3)	(4)	(5)	(6)	(7)	(8)	(9)	(10)	(11)	(12)	(13)	(14)	(15)	(16)	(17)	(18)	(19)	(20)	(21)	
20	2	3	5	6	8	10	11	13	14	16	18	19	21	22	24	26	27	29	30	32	
30	2	5	7	10	12	14	17	19	22	24	26	29	31	34	36	38	41	43	46	48	
40	3	6	10	13	16	19	22	26	29	32	35	38	42	45	48	51	54	58	61	64	
50	4	8	12	16	20	24	28	32	36	40	44	48	52	56	60	64	68	72	76	80	
60	5	10	14	19	24	29	34	38	43	48	53	58	62	67	72	77	82	86	91	96	
70	6	11	17	22	28	34	39	45	50	56	62	67	73	78	84	90	95	101	106	112	
80	6	13	19	26	32	38	45	51	58	64	70	77	83	90	96	102	109	115	122	128	
90	7	14	22	29	36	43	50	58	65	72	79	86	94	101	108	115	122	130	137	144	
100	8	16	24	32	40	48	56	64	72	80	88	96	104	112	120	128	136	144	152	160	
110	9	18	26	35	44	53	62	70	79	88	97	106	114	123	132	141	150	158	167	176	
120	10	19	29	38	48	58	67	77	86	96	106	115	125	134	144	154	163	173	182	192	
130	10	21	31	42	52	62	73	83	94	104	114	125	135	146	156	166	177	187	198	208	
140	11	22	34	45	56	67	78	90	101	112	123	134	146	157	168	179	190	202	213	224	
150	12	24	36	48	60	72	84	96	108	120	132	144	156	168	180	192	204	216	228	240	
200	16	32	48	64	80	96	112	128	144	160	176	192	208	224	240	256	272	288	304	320	
250	20	40	60	80	100	120	140	160	180	200	220	240	260	280	300	320	340	360	380	400	
300	24	48	72	96	120	144	168	192	216	240	264	288	312	336	360	384	408	432	456	480	
400	32	64	96	128	160	192	224	256	288	320	352	384	416	448	480	512	544	576	608	640	
500	40	80	120	160	200	240	280	320	360	400	440	480	520	560	600	640	680	720	760	800	
1 000	80	160	240	320	400	480	560	640	720	800	880	960	1 040	1 120	1 200	1 280	1 360	1 440	1 520	1 600	
2 000	160	320	480	640	800	960	1 120	1 280	1 440	1 600	1 760	1 920	2 080	2 240	2 400	2 560	2 720	2 880	3 040	3 200	
3 000	240	480	720	960	1 200	1 440	1 680	1 920	2 160	2 400	2 640	2 880	3 120	3 360	3 600	3 840	4 080	4 320	4 560	4 800	

4.5.13 Subsoil Water Drainage

4.5.13.1 General

Subsoil water is that portion of the rainfall which is absorbed into the ground.

The drainage of subsoil water may be necessary for the following reasons:

- a) To increase the stability of the surface;
- b) To avoid surface flooding;
- c) To alleviate or to avoid causing dampness in the building, especially in the cellars;
- d) To reduce the humidity in the immediate vicinity of the building; and
- e) To increase the workability of the soil.

4.5.13.2 Depth of water table

The standing level of the subsoil water will vary with the season, the amount of rainfall and the proximity and level of drainage channels. Information regarding this level may be obtained by means of boreholes or trial pits, preferably the latter. It is desirable though not always practicable to ascertain the level of the standing water over a considerable period so as to enable the seasonal variations to be recorded and in particular the high water level. The direction of flow of the subsoil water may usually be judged by the general inclination of the land surface and the main lines of the subsoil drains shall follow the natural falls, wherever possible.

4.5.13.3 Precautions

Subsoil drains shall be so sited as not to endanger the stability of the buildings or earthwork. In some portions of the drain, it may be necessary to use non-porous jointed pipes.

4.5.13.3.1 No field pipe shall be laid in such a manner or in such a position as to communicate directly with any drain constructed or adopted to be used for conveying sewage, except where absolutely unavoidable and in such case a suitable efficient trap shall be provided between subsoil drain and such sewer.

4.5.13.4 Systems of subsoil drainage

Clay or concrete porous field drain pipes may be used and shall be laid in one of the following ways (*see also* Fig. 13):

- a) *Natural* — The pipes are laid to follow the natural depressions or valleys of the site; branches discharge into the main as tributaries do into a river.
- b) *Herringbone* — The system consists of a number of drains into which discharges from both sides smaller subsidiary branch drains parallel to each other, but an angle to the mains forming a series of herringbone pattern.

Normally these branch drains should not exceed 30 m in length.

- c) *Grid* — A main or mains drain is laid to the boundaries if the site into which subsidiary branches discharge from one side only.
- d) *Fan-shaper* — The drains are laid converging to a single outlet at one point on the boundary of a site, without the use of main or collecting drains.
- e) *Moat or cut-off system* — This system consists of drains laid on one or more sides of a building to intercept the flow of subsoil water and carry it away, thereby protecting the foundations of a building.

The choice of one or more of these systems will naturally depend on the local conditions of the site. For building sites, the mains shall be not less than 75 mm in diameter and the branches not less than 65 mm in diameter but normal practice tends towards the use of 100 mm and 75 mm, respectively. The pipes shall generally be laid at 60 to 90 cm depth, or to such a depth to which it is desirable to lower the water-table and the gradients are determined rather by the fall of the land than by considerations of self-cleansing velocity. The connection of the subsidiary drain to the main drain is best made by means of a clayware or concrete junction pipe. The outlet of a subsoil system may discharge into a soakaway or through a catch pit into the nearest ditch or watercourse. Where these are not available, the subsoil drains may be connected, with the approval of the Authority, through an intercepting trap to the surface water drainage system.

NOTE — Care shall be taken that there is no backflow from sub-surface drains during heavy rains.

4.5.13.5 Deep well/borewell recharging

Recharge well is one which pushes back surface water into ground water system. The recharge well may be of 1 m in diameter and 6 m deep lined with concrete rings having perforations.

Direct recharge is recommended when the well has gone dry and is yielding negligible amount of water. Indirect recharge is adopted for functioning borewells.

4.5.14 Waste Disposal Systems in High Altitudes and/or Sub-Zero Temperature Regions

4.5.14.1 In general, all the care to be exercised regarding water supply systems shall also be applicable in the case of waste disposal systems. The biological and chemical reduction of organic material proceeds slowly under low temperature conditions, consequently affecting the waste disposal systems. The waste disposal methods given in 4.5.14.2, 4.5.14.3 and 4.5.14.4 shall be used only where it is not practical to install water carriage system.

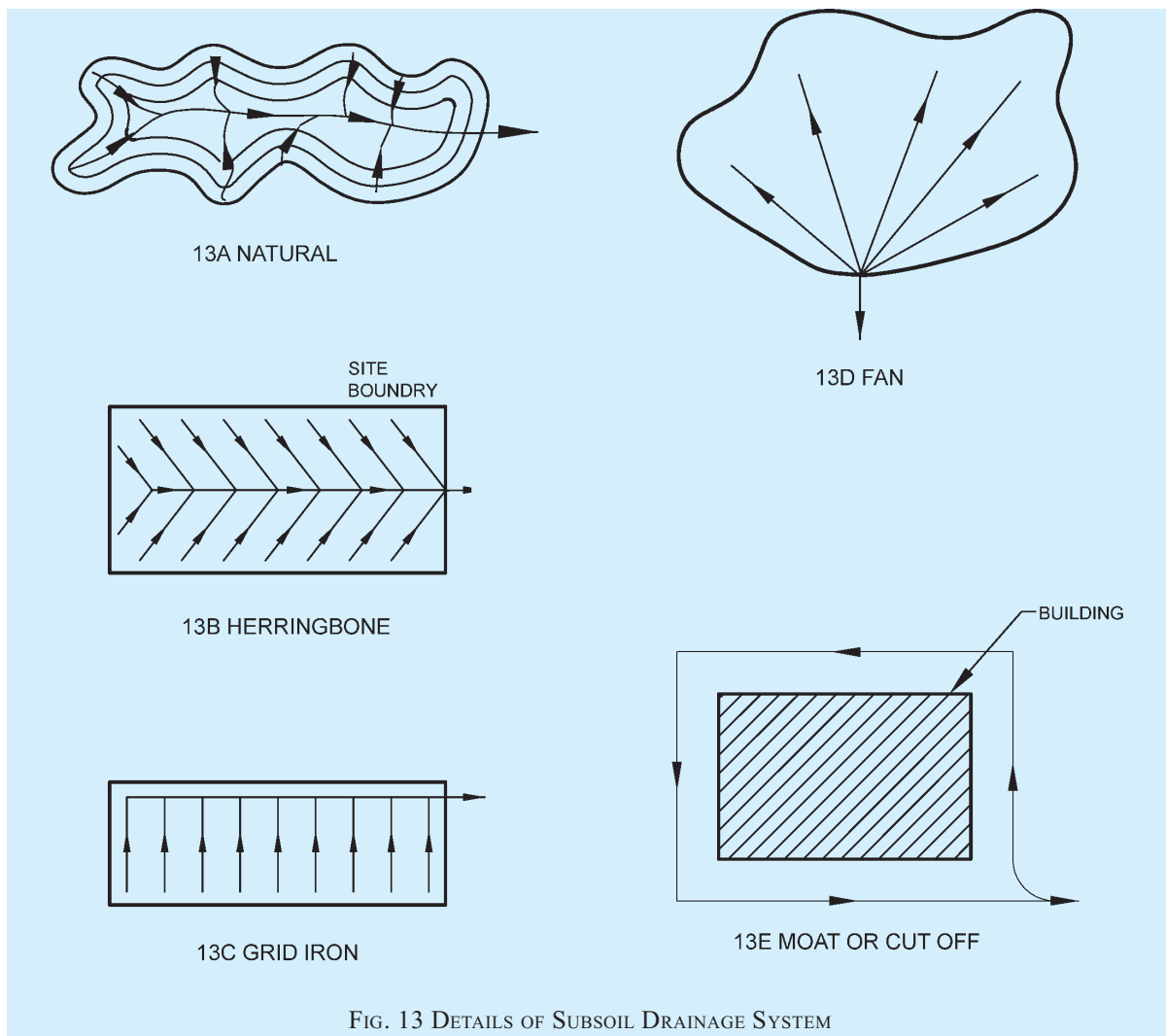

4.5.14.2 Box and can system

Where box and can systems are employed, adequate arrangements shall be made for the cleaning and disinfection of the can after it is emptied of its contents. The excrement from the can shall be disposed of by burial in isolated spots far from habitation or by incineration, where feasible. The can shall be fitted with a tight fitting lid for use when it is carried for emptying.

4.5.14.3 Trench or pit latrines

Trench or pit latrines shall be used only where soil and subsoil conditions favour their use. Whenever they are used, they shall not be closer than 18 m from any source of drinking water, such as well, to eliminate the possibility of bacterial pollution of water.

4.5.14.4 Chemical toilets

For the successful functioning of chemical toilets, they shall preferably be installed in heated rooms or enclosures.

NOTE — Chemical toilet essentially consists of small cylindrical tanks with a water-closer seat for the use of 8 to 10 persons. A ventilation pipe is fitted to the seat. A strong solution of caustic soda is used as a disinfectant. It kills bacteria, liquefies the solids and thus checks the decomposition of organic matter. The tank is provided with a drain plug for which liquid runs to a soak pit at the time of disposal.

4.5.14.5 Water-borne sanitation systems

Water-borne sanitation systems shall be used, where practicable. Sanitation systems for the collection of sewage should be constructed in such a manner that maximum heat is retained by insulation, if necessary.

4.5.14.5.1 Sewerage laying

Under normal circumstances, sewers shall be laid below the frost line. Manholes shall be made of air-tight construction so as to prevent the cold air from gaining access inside and freezing the contents. The trenches for sewers shall be loosely filled with earth after laying sewers, since loose soil is a better insulator than compacted soil. Consequently, sewers laid under traffic ways and other places where soil compaction may be

expected are required to be given adequate insulation. Where feasible, sewers shall be so located that the trench line is not in shadow, when the sun is shining. Concrete, cast iron and stoneware pipes conduct heat relatively rapidly and as such should be adequately insulated.

4.5.14.5.2 Septic tanks

Septic tanks can function only when it can be ensured that the contents inside these do not freeze at low temperature. For this purpose, the septic tanks shall be located well below the frost line. The location of manhole openings shall be marked by staves. Fencing around the septic tanks shall be provided for discouraging traffic over them. As the rate of biological activity is reduced by 50 percent for every 10°C fall in temperature, the capacity of septic tanks shall be increased by 100 percent for operation at 10°C over that for operation at 20°C.

The construction of septic tanks is preferred in rural and fringe areas of suburban and isolated buildings where underground system may neither be feasible nor economical. Septic tanks are only recommended for small communities and institutions whose contributory population does not exceed 300.

For other details, *see* good practice [9-2(9)].

4.5.14.5.3 Seepage pits

Seepage pits can function only when the soil and subsoil conditions are favourable. Frozen soil extending to a great depth would preclude the use of such disposal devices in view of the lower water absorption capacity. The discharge of effluent should be made below the frost line.

4.5.14.5.4 Sewage treatment plants

Suitable design modifications for sedimentation, chemical and biological processes shall be applied to sewage treatment plants for satisfactory functioning (*see also* 4.13).

NOTE — Lavatories and bathrooms shall be kept heated to avoid freezing of water inside traps and flushing cisterns.

4.6 Construction Relating to Conveyance of Sanitary Wastes

4.6.1 Excavation

4.6.1.1 General

The safety precautions as given in Part 7 'Construction Management, Practices and Safety' of the Code shall be ensured.

4.6.1.2 Turf, topsoil or other surface material shall be set aside, turf being carefully rolled and stacked for use in reinstatement. All suitable broken surface

material and hard-core shall be set on one side for use in subsequent reinstatement.

4.6.1.3 Excavated material shall be stacked sufficiently away from the edge of the trench and the size of the spoil bank shall not be allowed to become such as to endanger the stability of the excavation. Spoil may be carried away and used for filling the trench behind the work.

4.6.1.4 Excavation shall proceed to within about 75 mm of the finished formation level. This final 75 mm is to be trimmed and removed as a separate operation immediately prior to the laying of the pipes or their foundations.

4.6.1.5 Unless specified otherwise by the Authority, the width at bottom of trenches for pipes of different diameters laid at different depths shall be as given below:

- a) For all diameters, up to an average depth of 1 200 mm,
Width of trench, in mm = Diameter of pipe + 300 mm;
- b) For all diameters for depths above 1 200 mm,
Width of trench, in mm = Diameter of pipe + 400 mm; and
- c) Notwithstanding (a) and (b), the total width of trench at the top should not be less than 750 mm for depths exceeding 900 mm.

4.6.1.6 Excavation in roads shall be so arranged, in agreement with the proper authority, as to cause the minimum obstruction to traffic. The methods to be adopted shall depend on local circumstances.

4.6.1.7 All pipes, ducts, cables, mains or other services exposed in the trench shall be effectively supported by timber and/or chain or rope-slings.

4.6.1.8 All drainage sumps shall be sunk clear of the work outside the trench or at the sides of manholes. After the completion of the work, any pipes or drains leading to such sumps or temporary subsoil drains under permanent work shall be filled in properly with sand and consolidated.

4.6.2 Laying of Pipes

Laying of pipes shall be done in accordance with good practice [9-2(19)].

4.6.3 Jointing

All soil pipes, waste pipes, vent pipes and other such pipes above ground shall be gas-tight. All sewers and drains laid below the ground shall be water-tight. Jointing shall be done in accordance with good practice [9-2(19)].

4.6.4 Support or Protection for Pipes

4.6.4.1 General

It may be necessary to support or surround pipe sewers or drains by means of concrete in certain circumstances. Some of the suggested methods are given in 4.6.4.2 to 4.6.4.4.

4.6.4.2 Bedding

Bedding (see Fig. 14) shall be rectangular in section and shall extend laterally at least 150 mm beyond and on both sides of the projection of the barrel of the pipe. The thickness of the concrete below the barrel of the pipe shall be not less than 100 mm for pipes under 150 mm diameter and 150 mm for pipes 150 mm and over in diameter. Where bedding is used alone, the concrete shall be brought up at least to the invert level of the pipe to form a cradle and to avoid line contact between the pipe and the bed.

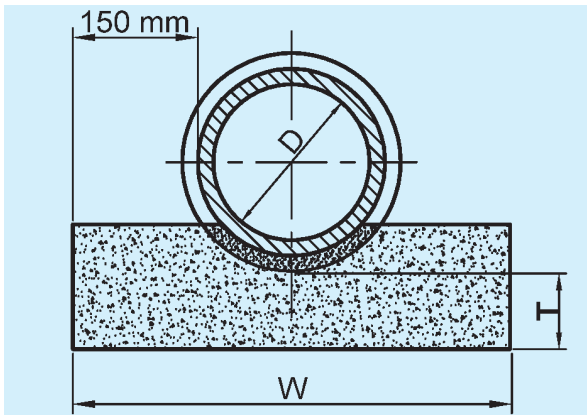

$W = D + 300 \text{ mm}$

where

$D =$ external diameter of the pipe.

$$T = \begin{cases} 100 \text{ mm for pipes under 150 mm nominal dia.} \\ 150 \text{ mm for pipes of 150 mm nominal dia and over.} \end{cases}$$

FIG. 14 BEDDING

4.6.4.3 Haunching

Concrete haunching (see Fig. 15) shall consist of,

- a) a concrete bed as described for bedding (see 4.6.4.2);
- b) the full width of the bed carried up to the level of the horizontal diameter of the pipe; and
- c) splays from this level carried up on both sides of the pipe, from the full width of the bed to meet the pipe barrel tangentially.

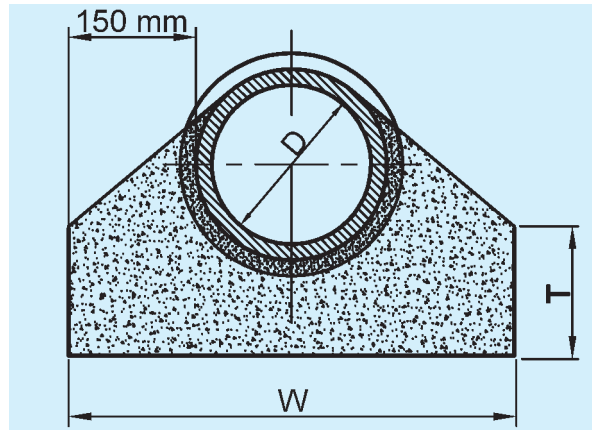

$W = D + 300 \text{ mm}$

where

$D =$ external diameter of the pipe.

$$T = \begin{cases} 100 \text{ mm for pipes under 150 mm nominal dia.} \\ 150 \text{ mm for pipes of 150 mm nominal dia and over.} \end{cases}$$

FIG. 15 HAUNCHING

4.6.4.4 Surround or encasing

The surround or encasing (see Fig. 16) shall be similar to haunching up to the horizontal diameter of the pipe and the top portion over this shall be finished in a semicircular form to give a uniform encasing for the top half of the pipe.

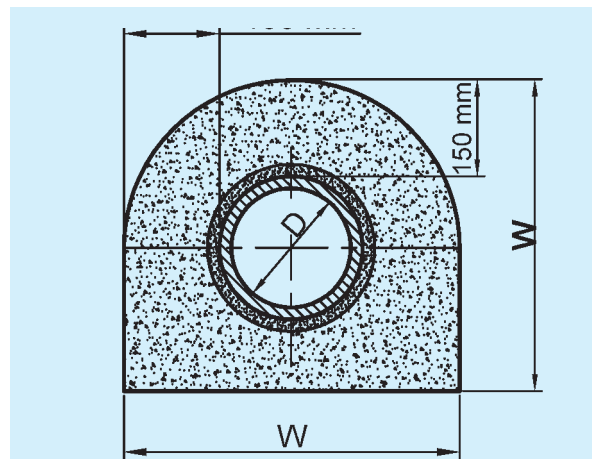

$W = D + 300 \text{ mm}$

where

$D =$ external diameter of the pipe.

FIG. 16 SURROUND OR ENCASING

4.6.5 Connection to Existing Sewers

The connection to an existing sewer shall, as far as possible, be done at the manholes. Where it is unavoidable to make connection in between two manholes, the work of breaking into the existing sewer and forming the connection shall be carried out by the Authority or under its supervision.

4.6.5.1 Breaking into the sewer shall be effected by the cautious enlargement of a small hole and every precaution shall be taken to prevent any material from entering the sewer. No connection shall be formed in such a way as to constitute a projection into the sewer or to cause any diminution in its effective size.

4.6.6 Back Filling

4.6.6.1 Filling of the trench shall not be commenced until the length of pipes therein has been tested and passed (*see 4.10.2*).

4.6.6.2 All timber which may be withdrawn with safety shall be removed as filling proceeds.

4.6.6.3 Where the pipes are unprotected by concrete haunching, the first operation in filling shall be carefully done to hand-pack and tamp selected fine material around the lower half of the pipes so as to buttress them to the sides of the trench.

4.6.6.4 The filling shall then be continued to 150 mm over the top of the pipe using selected fine hand-packed material, watered and rammed on both sides of the pipe with a wooden rammer. On no account shall material be tipped into the trench until the first 150 mm of filling has been completed. The process of filling and tamping shall proceed evenly so as to maintain an equal pressure on both sides of the pipeline.

4.6.6.5 Filling shall be continued in layers not exceeding 150 mm in thickness, each layer being watered and well rammed.

4.6.6.6 In roads, surface materials previously excavated shall be replaced as the top layer of the filling, consolidated and maintained satisfactorily till the permanent reinstatement of the surface is made by the Authority.

4.6.6.7 In gardens, the top soil and turf, if any, shall be carefully replaced.

4.7 Construction Relating to Conveyance of Rain or Storm Water

4.7.1 Roof Gutters

Roof gutters shall be of any material of suitable thickness. All junctions and joints shall be water-tight.

4.7.2 RainWater Pipes

Rainwater pipes shall conform to the accepted standards [9-2(20)].

4.7.3 Subsoil Drain Pipes

4.7.3.1 Field drain pipes

Suitable pipes for this purpose are plain cylindrical glazed water pipes, or concrete porous pipes, though the latter may prove unsuitable where subsoil water carries sulphates or is acidic owing to the presence of peat. Trenches for these pipes need be just wide enough at the bottom to permit laying the pipes, which shall be laid with open joints to proper lines and gradients.

It is advisable to cover the pipes with clinker free from fine ash, brick ballast or other suitable rubble, or a layer of inverted turf, brush-wood or straw before refilling the trench, in order to prevent the infiltration of silt through the open joints. Where the subsoil drain is also to serve the purpose of collecting surface water, the rubble shall be carried up to a suitable level and when required for a lawn or playing field, the remainder of the trench shall be filled with pervious top soil. When refilling the trenches, care shall be taken to prevent displacement of pipes in line of levels. When they pass near trees or through hedges, socket pipes with cement or bitumen joints shall be used to prevent penetration by roots.

4.7.3.2 French drain

A shallow trench is excavated, the bottom neatly trimmed to the gradient and the trench filled with broken stone, gravel or clinker, coarse at the bottom and finer towards the top.

4.8 Selection and Installation of Sanitary Appliances

Selection, installation and maintenance of sanitary appliances shall be done in accordance with good practice [9-2(21)].

4.9 Refuse Chute System

The refuse chute system provided shall be in accordance with Part 9 'Plumbing Services, Section 3 Solid Waste Management' of the Code.

4.10 Inspection and Testing

4.10.1 Inspection

4.10.1.1 All sanitary appliances and fittings shall be carefully examined for defects before they are installed and also on the completion of the work.

4.10.1.2 Pipes are liable to get damaged in transit and, notwithstanding tests that may have been made before despatch, each pipe shall be carefully examined on arrival on the site. Preferably, each pipe shall be rung with a hammer or mallet and those that do not ring true and clear shall be rejected. Sound pipes shall be carefully stored to prevent damage. Any defective pipes shall be segregated, marked in a conspicuous manner and their use in the works prevented.

4.10.1.3 Cast iron pipes shall be carefully examined for damage to the protective coating. Minor damage shall be made good by painting over with hot tar or preferably bitumen. But if major defects in coating exist, the pipes shall not be used unless recoated. Each pipe shall be carefully re-examined for soundness before laying.

4.10.1.4 Close inspection shall be maintained at every stage in the work, particularly as to the adequacy of timber supports used in excavation and the care and thoroughness exercised in filling.

4.10.1.4.1 Careful note shall be kept of the condition of any sewer, manhole or other existing work which may be uncovered and any defects evident shall be pointed out immediately to the Authority.

4.10.1.4.2 No work shall be covered over or surrounded with concrete until it has been inspected and approved by the Authority.

4.10.2 Testing

4.10.2.1 Comprehensive tests of all appliances shall be made by simulating conditions of use. Overflow shall be examined for obstructions.

4.10.2.2 Smoke test

All soil pipes, waste pipes, and vent pipes and all other pipes when above ground shall be approved gas-tight by a smoke test conducted under a pressure of 25 mm of water and maintained for 15 min after all trap seals have been filled with water. The smoke is produced by burning only waste or tar paper or similar material in the combustion chamber of a smoke machine. Chemical smokes are not satisfactory.

4.10.2.3 Water test

4.10.2.3.1 For pipes other than cast iron

Glazed and concrete pipes shall be subjected to a test pressure of at least 1.5 m head of water at the highest point of the section under test. The tolerance figure of 2 litre/cm of diameter/km may be allowed during a period of 10 min. The test shall be carried out by suitably plugging the low end of the drain and the ends of connections, if any, and filling the system with water. A knuckle bend shall be temporarily jointed in at the top end and a sufficient length of the vertical pipe jointed to it so as to provide the required test head, or the top end may be plugged with a connection to a hose ending in a funnel which could be raised or lowered till the required head is obtained and fixed suitably for observation.

Subsidence of the test water may be due to one or more of the following causes:

- a) Absorption by pipes and joints;
- b) Sweating of pipes or joints;
- c) Leakage at joints or from defective pipes; and
- d) Trapped air.

Allowance shall be made for (a) by adding water until absorption has ceased after which the test proper should commence. Any leakage will be visible and the defective part of the work should be cut out and made good. A slight amount of sweating which is uniform may be overlooked, but excessive sweating from a particular pipe or joint shall be watched for and taken as indicating a defect to be made good. A slight amount of sweating which is uniform may be overlooked, but excessive sweating from a particular pipe or joint shall be watched for and taken as indicating a defect to be made good.

NOTE — This test will not be applicable to sanitary pipe work above ground level.

4.10.2.3.2 For cast iron pipes

Cast iron sewers and drains shall be tested as for glazed and concrete pipes. The drain plug shall be suitably strutted to prevent their being forced out of the pipe during the test.

4.10.2.4 Tests for straightness and obstruction

The following tests shall be carried out:

- a) By inserting at the high end of the sewer or drain a smooth ball of a diameter 13 mm less than the pipe bore. In the absence of obstruction, such as yarn or mortar projecting through the joints, the ball should roll down the invert of the pipe, and emerge at the lower end; and
- b) By means of a mirror at one end of the line and lamp at the other. If the pipeline is straight, the full circle of light may be observed. If the pipe line is not straight, this will be apparent. The mirror will also indicate obstruction in the barrel.

4.10.2.5 Test records

Complete records shall be kept of all tests carried out on sewers and drains both during construction and after being put into service.

4.11 Maintenance

4.11.1 General

Domestic drainage system shall be inspected at regular intervals. The system shall be thoroughly cleaned out at the same time and any defects discovered shall be made good.

4.11.2 Cleaning of Drainage System

4.11.2.1 Sewer maintenance crews, when entering a deep manhole or sewer where dangerous gas or oxygen deficiencies may be present, shall follow the following procedures:

- a) Allow no smoking or open flames and guard against sparks.

- b) Erect warning signs.
- c) Use only safety gas-proof, electric lighting equipment.
- d) Test the atmosphere for noxious gases and oxygen deficiencies (presence of hydrogen sulphide is detected using lead acetate paper and that of oxygen by safety lamps).
- e) If the atmosphere is normal, workmen may enter with a safety belt attached and with two men available at the top. For extended jobs, the gas tests shall be repeated at frequent intervals, depending on circumstances.
- f) If oxygen deficiency or noxious gas is found, the structure shall be ventilated with pure air by keeping open at least one manhole cover each on upstream and downstream side for quick exit of toxic gases or by artificial means. The gas tests shall be repeated and the atmosphere cleared before entering. Adequate ventilation shall be maintained during this work and the tests repeated frequently.
- g) If the gas or oxygen deficiency is present and it is not practicable to ventilate adequately before workers enter, a hose mask shall be worn and extreme care taken to avoid all sources of ignition. Workers shall be taught how to use the hose equipment. In these cases, they shall always use permissible safety lights (not ordinary flash lights), rubber boots or non-sparking shoes and non-sparking tools;
- h) Workmen descending a manhole shaft to inspect or clean sewers shall try each ladder step or rung carefully before putting the full weight on it to guard against insecure fastening due to corrosion of the rung at the manhole wall. When work is going on in deep sewers, at least two men shall be available for lifting workers from the manhole in the event of serious injury; and
- j) Portable air blowers, for ventilating manhole, are recommended for all tank, pit or manhole work where there is a question as to the presence of noxious gas, vapours or oxygen deficiency. The motors for these shall be of weather proof and flame-proof types; compression ignition diesel type (without sparking plug) may be used. When used, these shall be placed not less than 2 m away from the opening and on the leeward side protected from wind, so that they will not serve as a source of ignition for any inflammable gas which might be present. Provision should be made for ventilation and it should be of the forced type which can be provided by a blower

located at ground level with suitable flexible ducting to displace out air from the manhole.

4.11.2.2 The following operations shall be carried out during periodical cleaning of a drainage system:

- a) The covers of inspection chambers and manholes shall be removed and the side benching and channels scrubbed;
- b) The interceptive trap, if fitted, shall be adequately cleaned and flushed with clean water. Care shall be taken to see that the stopper in the rodding arm is securely replaced;
- c) All lengths of main and branch drains shall be rodded by means of drain rods and a suitable rubber or leather plunger. After rodding, the drains shall be thoroughly flushed with clean water. Any obstruction found shall be removed with suitable drain cleaning tools and the system thereafter shall be flushed with clean water;
- d) The covers of access plates to all gullies shall be removed and the traps plunged and flushed out thoroughly with clean water. Care shall be taken not to flush the gully deposit into the system;
- e) Any defects revealed as a result of inspection or test shall be made good;
- f) The covers or inspection chambers and gullies shall be replaced, bedding them in suitable grease or other materials; and
- g) Painting of ladders/rings in deep manholes and external painting of manhole covers shall be done with approved paints.

4.11.3 All surface water drains shall be periodically rodded by means of drain rods and a suitable rubber or leather plunger. After rodding, they shall be thoroughly flushed with clean water. Any obstruction found shall be removed with suitable drain cleaning tools.

4.11.4 All subsoil drains shall be periodically examined for obstruction at the open joints due to the roots of plants or other growths.

4.12 Pumping of Sewage

4.12.1 In the design of sewerage system, it is necessary to collect the sewage of a low lying area at some convenient point from which it shall be lifted by pumps. At the treatment plant also, lifting of sewage may be necessary to provide head for the flow by gravity of sewage.

4.12.2 Sewage Pump Stations, Sizing of Sumps and Pumps

They are required as onsite pump stations to cater to drainage from toilets and kitchen. The stations would

be located in basement floors and leading the sewage to onsite treatment plants. Submersible centrifugal pumps are used for pumping the sewage. The sump capacity depends on effective holding capacity considering the flow from drainage fixtures. Usually, retention period of 15 min is adopted. The size of sump depends on the availability of space. Minimum size of discharge pipe may be 80 mm with a velocity of 1 m/s and pumps are sized for 100 percent design flow.

NOTE — For other details reference to good practice [9-2(12)] shall be made.

4.13 Sewage Treatment Systems

4.13.1 Sewage treatment is the process of removing contaminants from waste water, primarily from household sewage. It includes physical, chemical and biological processes to remove these contaminants and produce environmentally safe treated waste water (or treated effluent).

The by-product of sewage treatment is usually a semisolid waste or slurry, called sewage sludge, that has to undergo further treatment before being suitable for disposal or further application (*see* Fig. 17).

4.13.2 The main objective of treating waste water is to stabilize decomposable organic matter present in the sewage so as to produce treated effluent and sludge, which can be disposed of in the environment without causing health hazards or nuisance.

The microbial population in treatment process can be cultured using the following systems:

- a) *Suspended growth system* — In this system, microorganisms remain in suspension and their concentration is related to mixed liquor suspended solids (MLSS).
- b) *Attached growth system* — In this system, microorganisms are developed over mobile or immobile solid covered in biomass (slime).
- c) *Combined growth system* — In this system, both systems are used to attain the shock loads.

Suspended growth system is generally proposed due to its merits and excellent performance.

4.13.3 Technologies

Following technologies for sewage treatment shall be considered based on the requirement:

- a) *Extended aeration with activated sludge process (EAASP)* — Activated sludge process is the biological process by which non-settleable substances occurring in dissolved and colloidal forms are converted into

settleable sludge which is removed from the liquid carrier (water).

This process is well suitable for completely populated community and does not require skilled labour for handling the plant. It is time tested and requires more number of units to achieve biological oxygen demand (BOD) less than 10 ppm, like coagulants required for better quality.

- b) *Sequential batch reactor (SBR)* — It is an activated sludge process designed to operate under non-steady state conditions. An SBR operates in a true batch mode with aeration and sludge settlement both occurring in the same tank. There is a degree of flexibility associated with working in a time rather than in a space sequence.

Plant for this process requires less space due to batch process, well suitable for modular growth. It can handle smallest flows and the desired quality can be achieved without coagulants. It requires good quality of decanters, and skilled labour as the process is timer-based automation.

- c) *Membrane bio-reactor (MBR)* — It is a continuous process of activated sludge treatment, but solids separation is done through pressurised system or through media. As there is physical barrier for solid separation, quality of treatment is good.

It is suitable for any type of growth pattern and can handle smaller flows. It requires less space, and skilled labours to handle.

- d) *Rotating bio-bed reactor (RBBR)* — It is combined growth process. Bacteria are allowed to grow on media, which is exposed to atmospheric air. It is also known as rotating biological contactor (RBC).

It is suitable for smaller capacities and does not require skilled labour to handle. The quality of treatment is good.

- e) *Fluidized bio-bed reactor (FBBR)* — In this process, cells are immobilized in small particles which move with the fluid. The small particles create a large surface area for cells to stick and enable a high rate of transfer of oxygen and nutrients to the cells. It is also known as moving bed bio reactor (MBBR). It is suitable for all type of communities, does not require skilled labour and requires less space. It can be installed for all capacities and the quality of treatment is good.

- f) *Submerged aerobic fixed film reactor (SAFF)* — It is a combined growth process in

which bio-media is fixed and bacteria are allowed to grow on media, which has air supply from below.

It does not require skilled labour. Supporting structure for media should be anti-corrosive to enable media fixing.

- g) *Trickling filters* — It is an attached growth process where media is used to grow bacteria by trickling sewage over the media. It is an old concept and is not now widely used.

- h) *Oxidation ponds/lagoons* — Oxidation ponds, also called lagoons or stabilization ponds are large shallow ponds designed to treat wastewater through the interaction of sunlight, bacteria, and algae.

4.14 Treatment of Waste Water and Usage of Recycled Water

See 4.2.4 of Part 9 ‘Plumbing Services, Section 1 Water Supply’ of the Code.

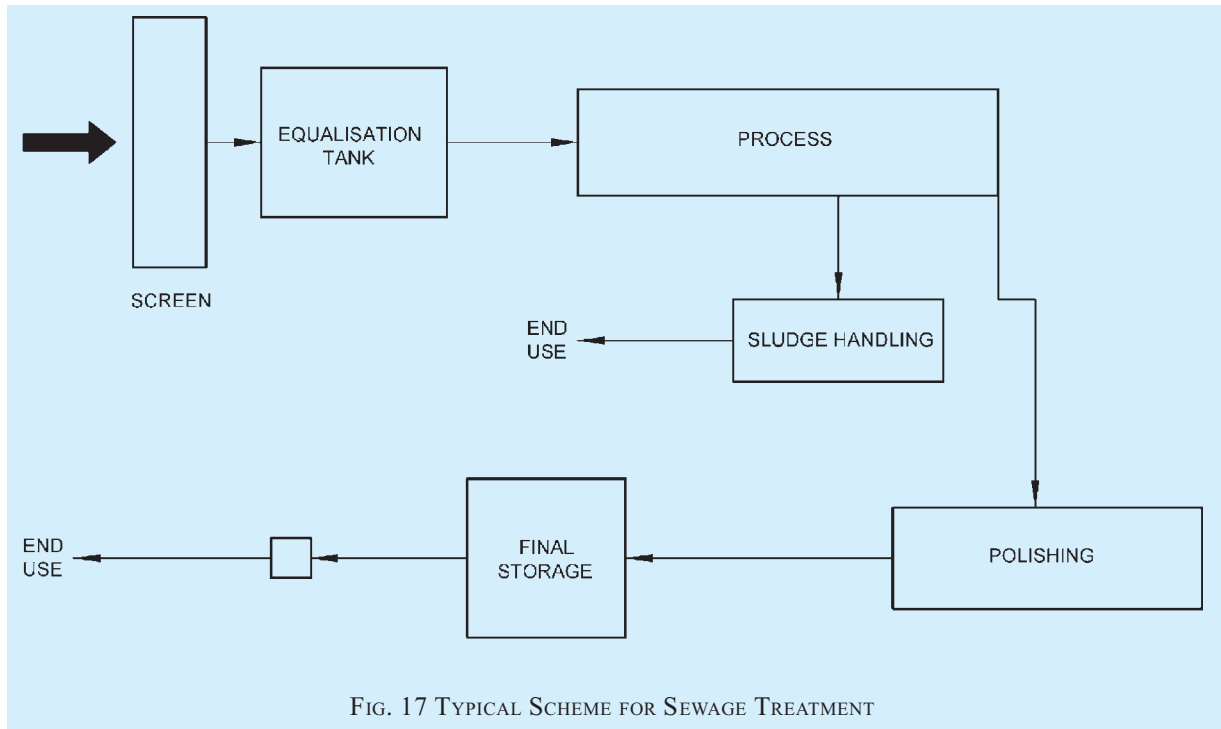

FIG. 17 TYPICAL SCHEME FOR SEWAGE TREATMENT

ANNEX A

(Clause 3.2.1)

APPLICATION FOR DRAINAGE OF PREMISES

I/We hereby make application to the *.....
 for permission to drain the premises.....Ward
 No.....Street No..... Road/Street known as.....

The sanitary arrangement and drains of the said premises are shown in the accompanying plans and a description of the specification of the work/material used is also appended (*see Annex B*).

I/We undertake to carry out the work in accordance with Part 9 ‘Plumbing services, Section 2 Drainage and sanitation’ of the National Building Code of India.

..... Signature of the licensed/registered plumber Name and address of the Date..... Signature of the owner Name and address..... Date.....
---	---

NOTE — The application should be signed by the owner of the premises and shall be countersigned by the licensed/registered plumber.

 * Insert the name of the Authority.

ANNEX B

(Clause 3.2.3.2)

**FORM FOR DETAILED DESCRIPTION OF WORK
 AND SPECIFICATION OF MATERIALS**

- 1) Separation of rainwater and foul water.....
- 2) Rainwater drains, curbs and points of discharge
- 3) Rainwater gutters, pipes or spouts where discharging.....
- 4) Open-full-water drains, materials, sizes, curbs and other means places, verandahs, latrines
- 5) Silt-catcher and grating, size and position
- 6) Drains
- a) Main sewage drains: Fall
- Size
- b) Branch drains : Fall
- Size
- c) Materials.....
- d) Method of jointing.....

ANNEX B — (Continued)

- 7) Bedding of pipes:
 - a) Method of bedding.....
 - b) Thickness and width of beds of concrete
 - c) Thickness of concrete round pipes
- 8) Protection of drain laid under wall
- 9) Traps, description and interceptor:
 - a) Lavatory waste pipes
 - b) Bath waste pipes
 - c) Sink
 - d) Gully-traps
 - e) Water closet traps.....
 - f) Grease traps
 - g) Slop sink
 - h) Urinal
 - j) Others
- 10) Manholes and inspection chambers:
 - a) Thickness of walls
 - b) Description of bricks
 - c) Description of rendering
 - d) Description of invert channels
 - e) Depth of chambers
 - f) Size and description of cover and manner of fixing.....
- 11) Ventilation of drain:
 - a) Position — Height above nearest ground level
 - b) Outlet shaft position of terminal at top
- 12) Soil pipe, waste pipe and vent pipe connections:
 - a) Lead and iron pipes.....
 - b) Lead pipe of trap with cast iron pipe
 - c) Stoneware pipe or trap with lead pipe
 - d) Lead soil pipe or trap with stoneware pipe or trap
 - e) Cast iron pipe with stoneware drain
 - f) Stoneware trap with cast iron soil pipe.....
- 13) Ventilation of water closet trap sink, lavatory and other traps material and supports.
- 14) Water closets (apartments):
 - a)
 - 1) At or above ground level
 - 2) Approached from
 - 3) Floor material
 - 4) Floor fall towards door
 - 5) Size of window opening in wall made to open
 - 6) Position of same
 - 7) Means of constant ventilation.....
 - 8) Position of same

ANNEX B — (Concluded)

- b) Water closet apparatus:
 - 1) Description of pan, basin, etc
 - 2) Kind
 - 3) Flushing cistern
 - 4) Material of flushing pipe
 - 5) Internal diameter
 - 6) Union with basin
- 15) Sanitary fittings, water storage tank, etc:
 - a) Number and description of sanitary fittings in room and rooms in which they are to be installed .
 - b) Capacity and position of water storage tanks
 - c) Size and number of draw off taps and whether taken off storage tanks or direct from main supply
 - d) Details of draw off taps, that is, whether they are of plain screw down pattern or ‘waste not’ and description of any other sanitary work to be carried out not included under above headings
- 16) Depth of sewer below surface of street.....
- 17) Level of invert of house drain at point of junction:
 - a) With sewer
 - b) Level of invert of sewer at point of junction with house drain
 - c) Distance of nearest manhole on sewer from the point at which the drain leaves the premises
- 18) Schedule of pipes:

<i>Description of Pipe/Drain</i>	<i>Materials</i>	<i>Diameter</i>	<i>Weight</i>	<i>Method of Jointing</i>
Subsoil drains				
Main sewage drains				
Branch sewage drains				
Soil pipes				
Vent pipes other than soil pipes				
Waste pipes				
Rainwater pipes				
Anti-syphon pipes				

Signature of the licensed/registered plumber

Name and address of the licensed/registered plumber

.....

.....

.....

Date

ANNEX C
(Clause 3.2.5)

FORM FOR LICENSED/REGISTERED PLUMBER'S COMPLETION CERTIFICATE

Certified that I/we have completed the plumbing work of drainage and sanitation system for the premises as detailed below. This may be inspected, approved and connection given.

Ward No

Street

Locality

Block No

House No

Details of work

.....

.....

The work was sanctioned by the Authority*
vide

..... Signature of the owner Name and address..... Date..... Signature of the licensed/registered plumber Name and address Date.....
--	---

The Authority's Report

Certified that the plumbing work of drainage and sanitation system for the premises, have been laid, applied, executed in accordance with Part 9 'Plumbing services, Section 2 Drainage and sanitation' of the National Building Code of India.

Drainage Connection to the main sewer will be made on.....

Date..... The Authority.....

* Insert the name of the Authority.

ANNEX D

(Clause 4.5.1.4)

TYPICAL MOUNTING ARRANGEMENTS FOR VARIOUS PLUMBING FIXTURES, INCLUDING DRAINAGE SYSTEMS AND VENTILATION

D-1 ARRANGEMENT FOR RECTANGULAR WASH BASIN

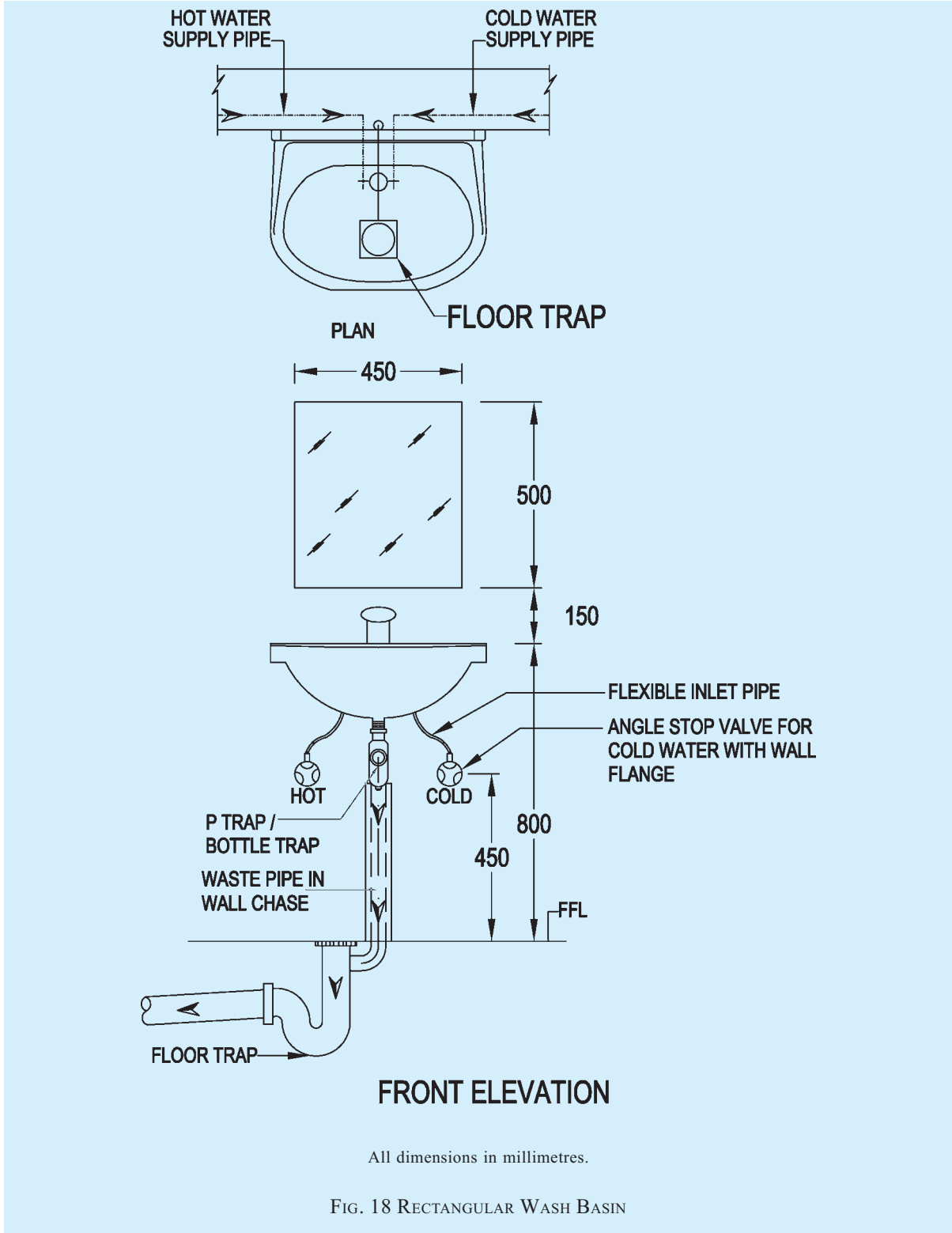

D-2 ARRANGEMENT FOR OVAL WASHBASIN (ABOVE COUNTER)

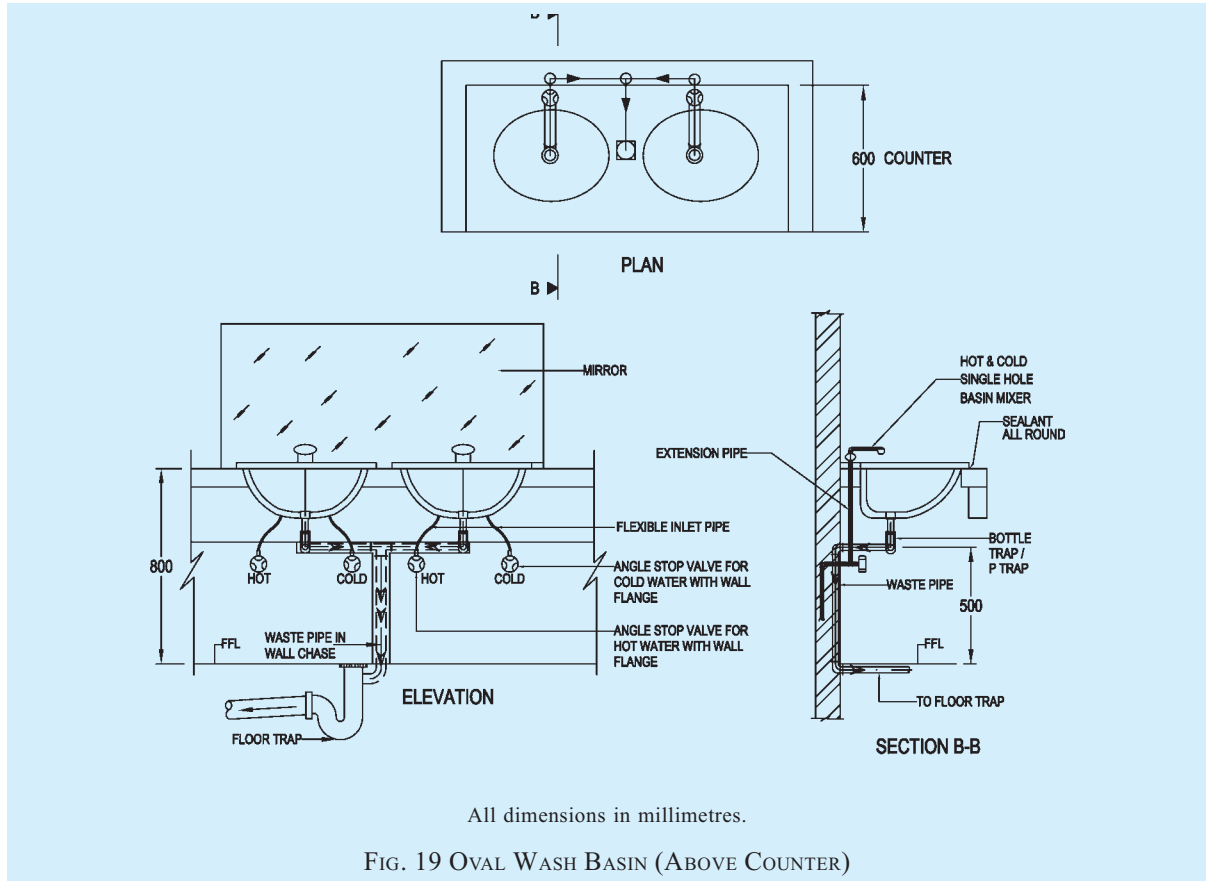

D-3 ARRANGEMENT FOR OVAL WASHBASIN (BELOW COUNTER)

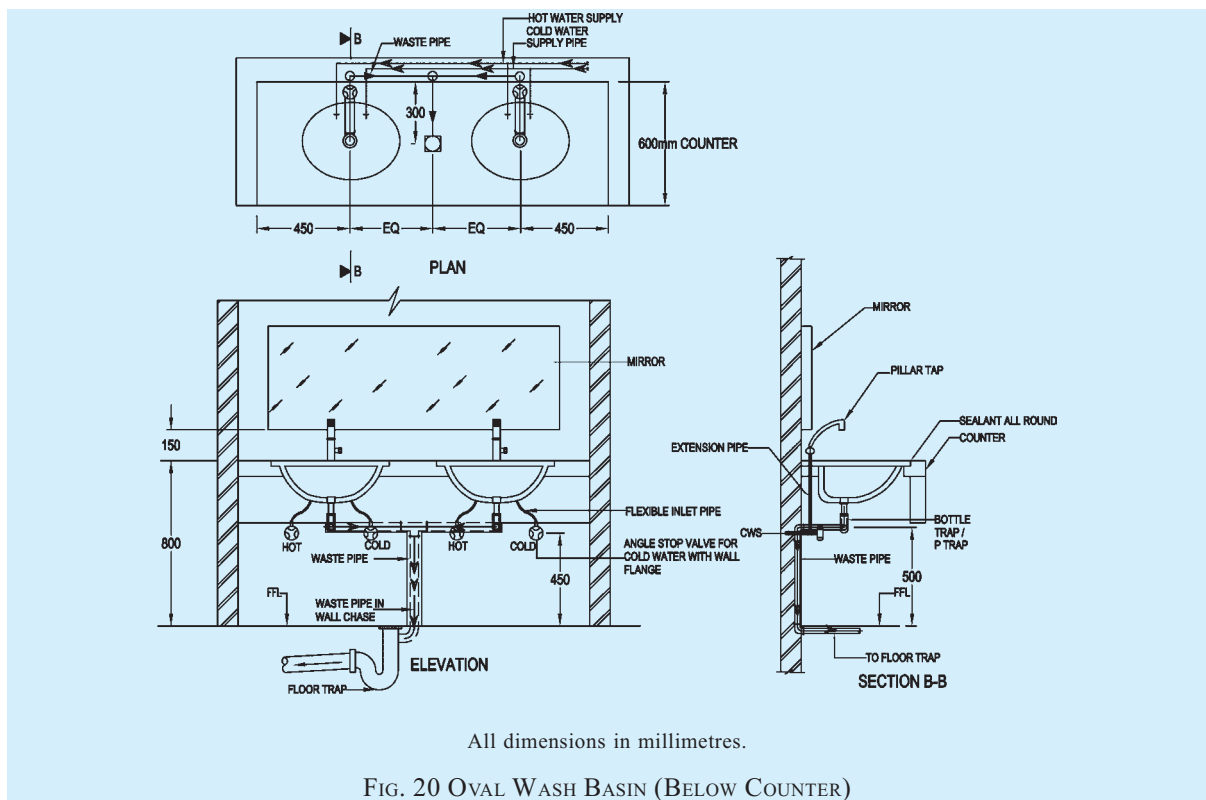

D-4 ARRANGEMENT FOR SINK

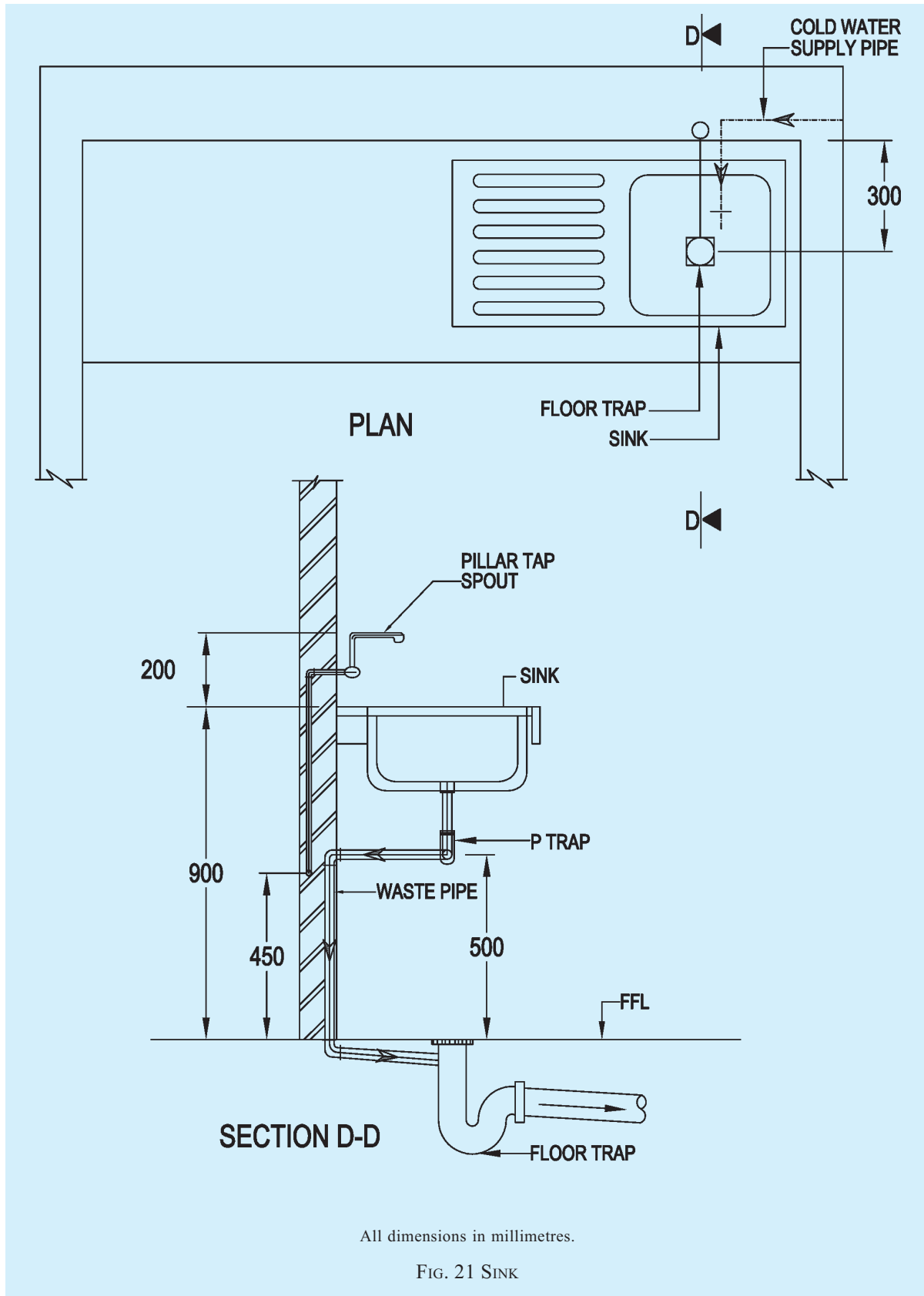

D-5 ARRANGEMENT FOR EUROPEAN WATER CLOSET (FLOOR MOUNTED WITH FLUSH TANK AND S-TRAP)

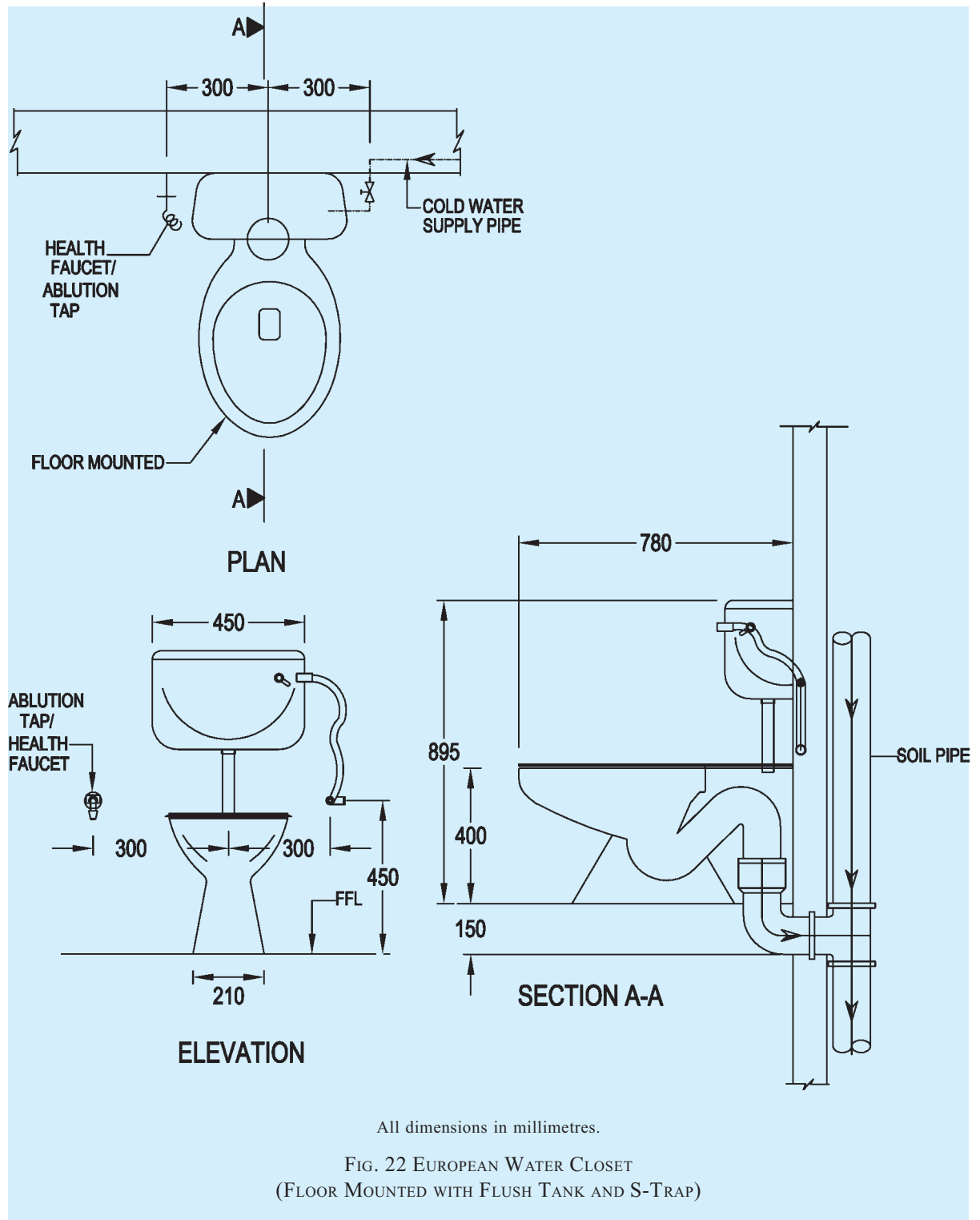

D-6 ARRANGEMENT FOR EUROPEAN WATER CLOSET (WALL HUNG WITH FLUSH VALVE)

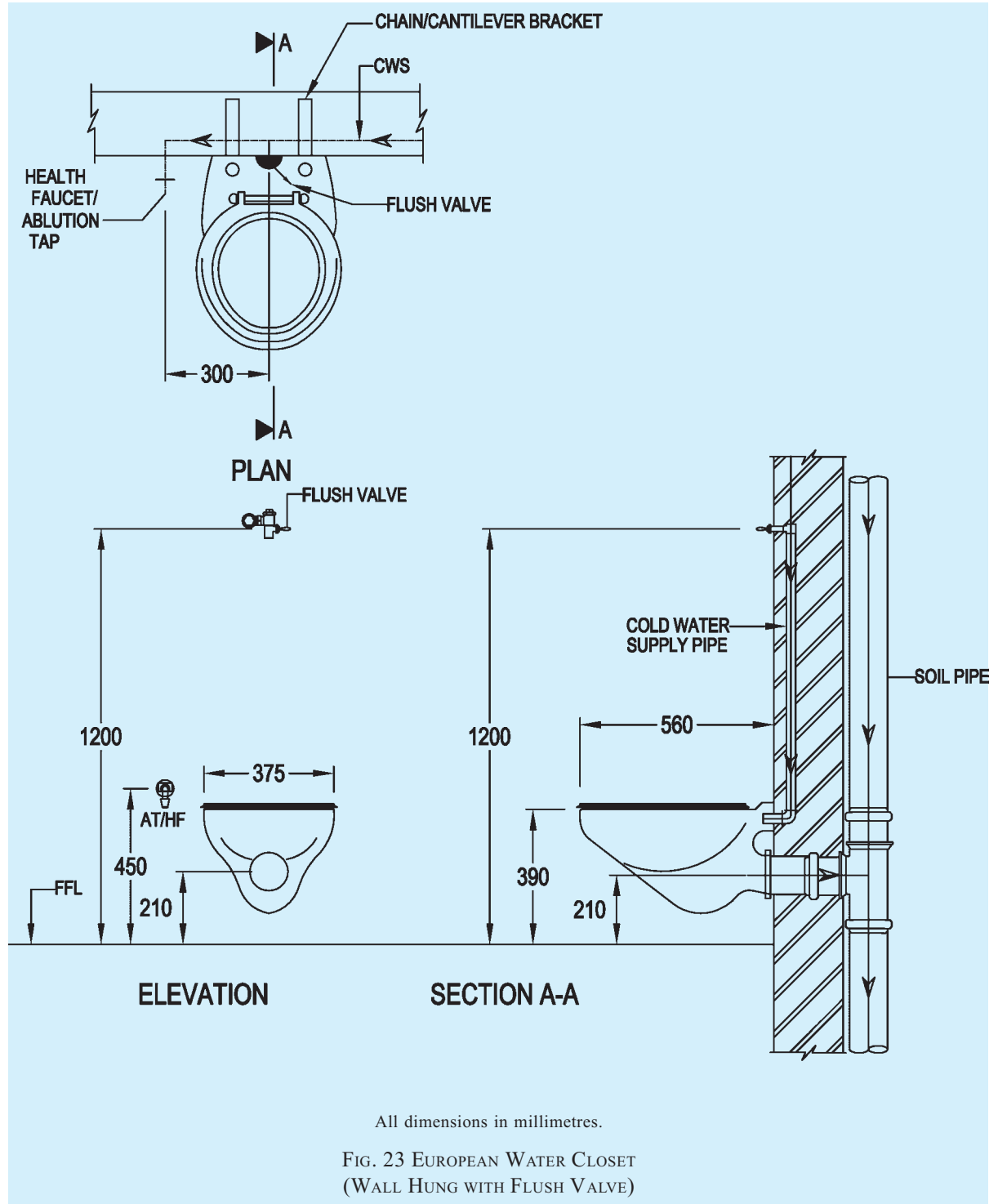

D-7 ARRANGEMENT FOR EUROPEAN WATER CLOSET (WALL HUNG WITH FLUSHING CISTERN)

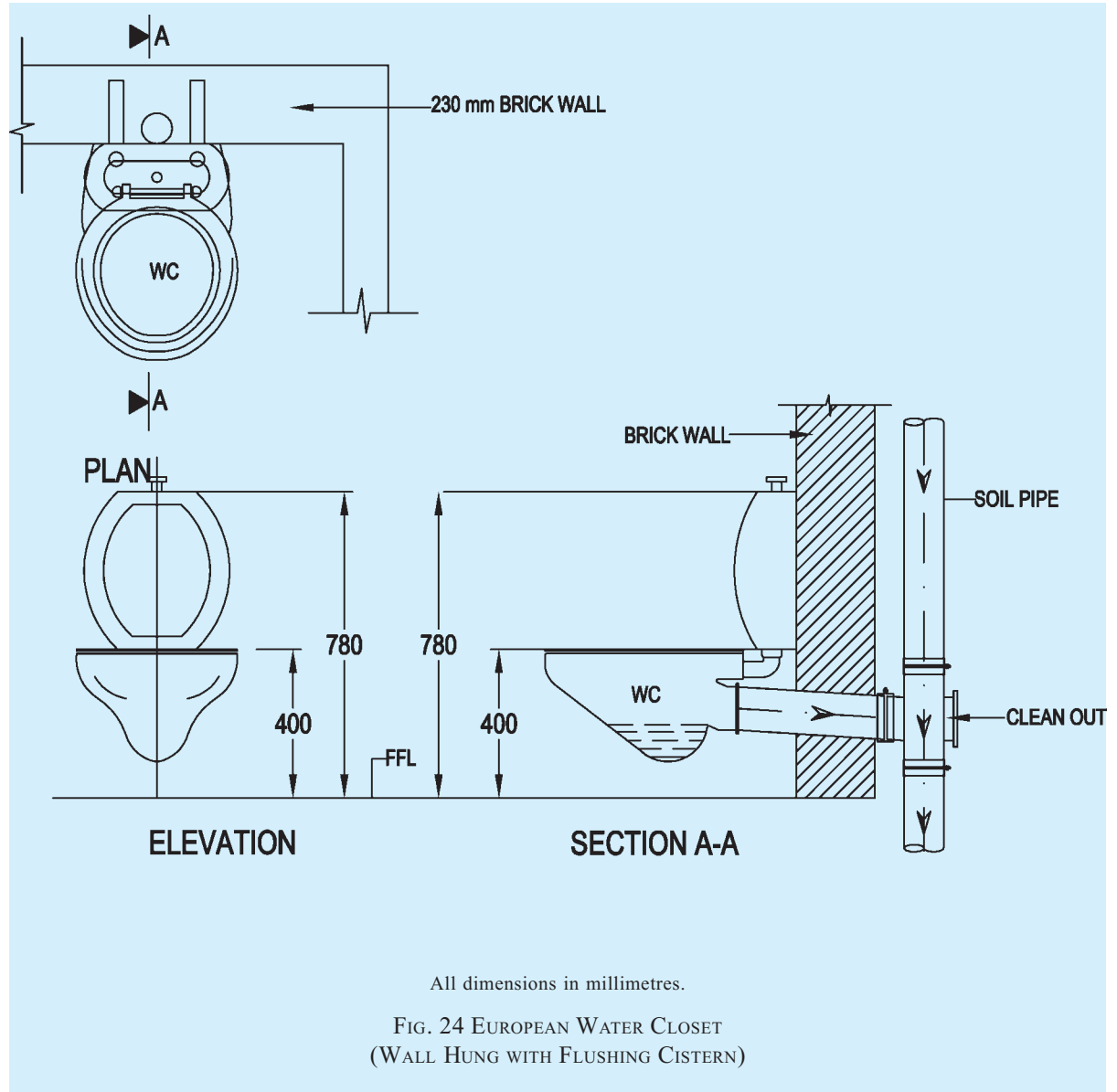

D-8 ARRANGEMENT FOR ORISSA PAN INDIAN WATER CLOSET

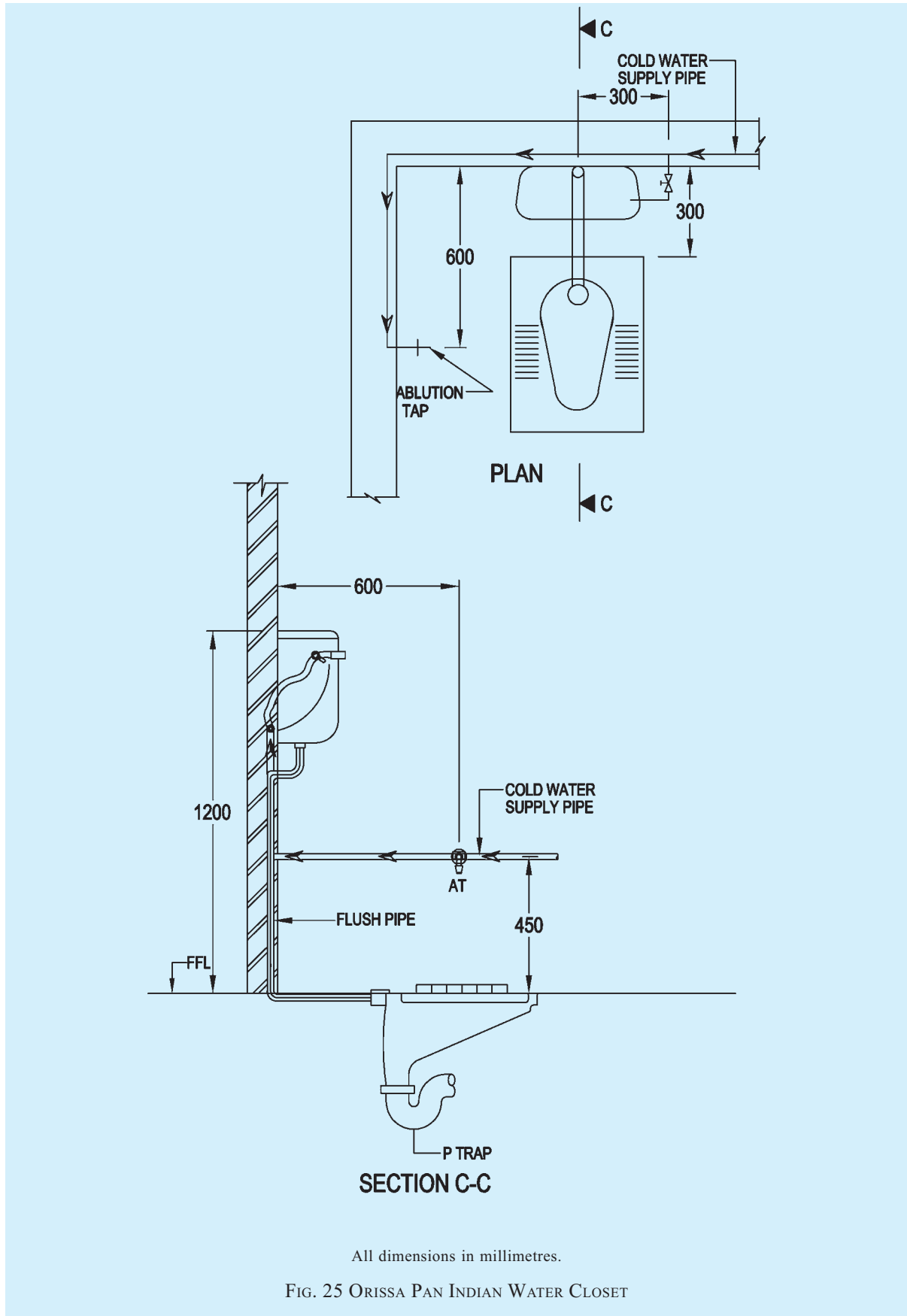

D-9 ARRANGEMENT FOR URINAL

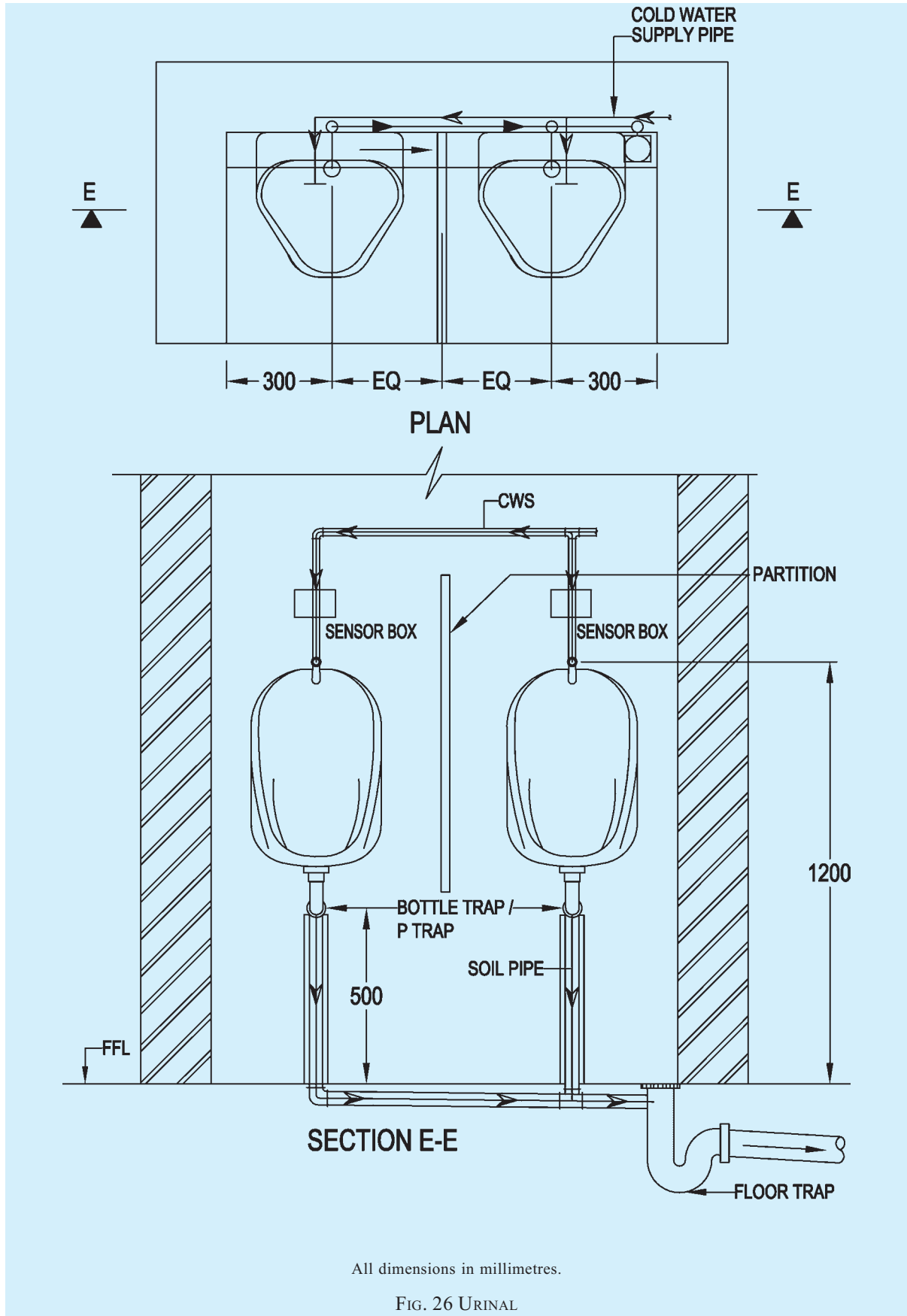

D-10 ARRANGEMENT FOR SHOWER

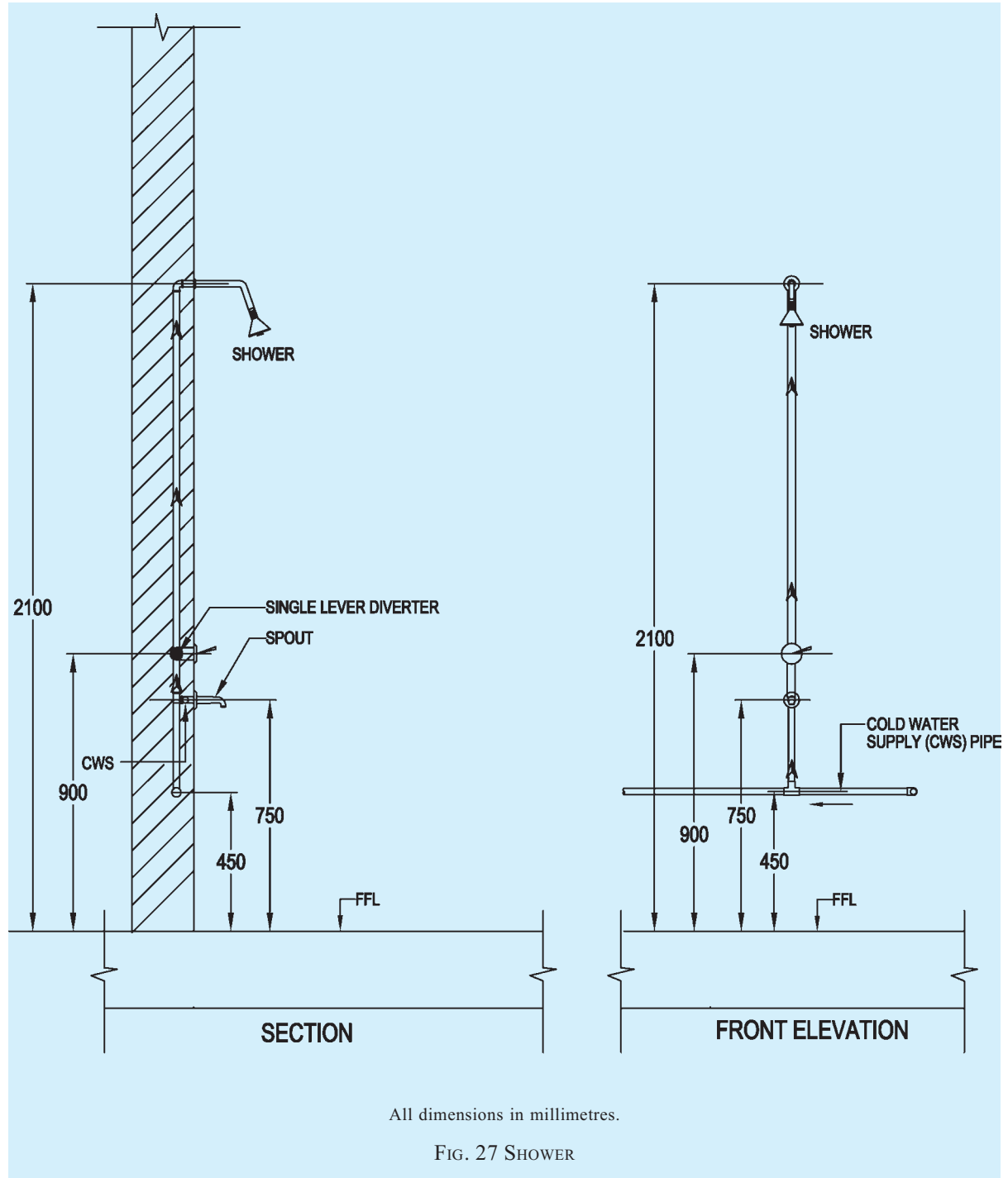

D-11 ARRANGEMENT FOR BATH TUB/SHOWER

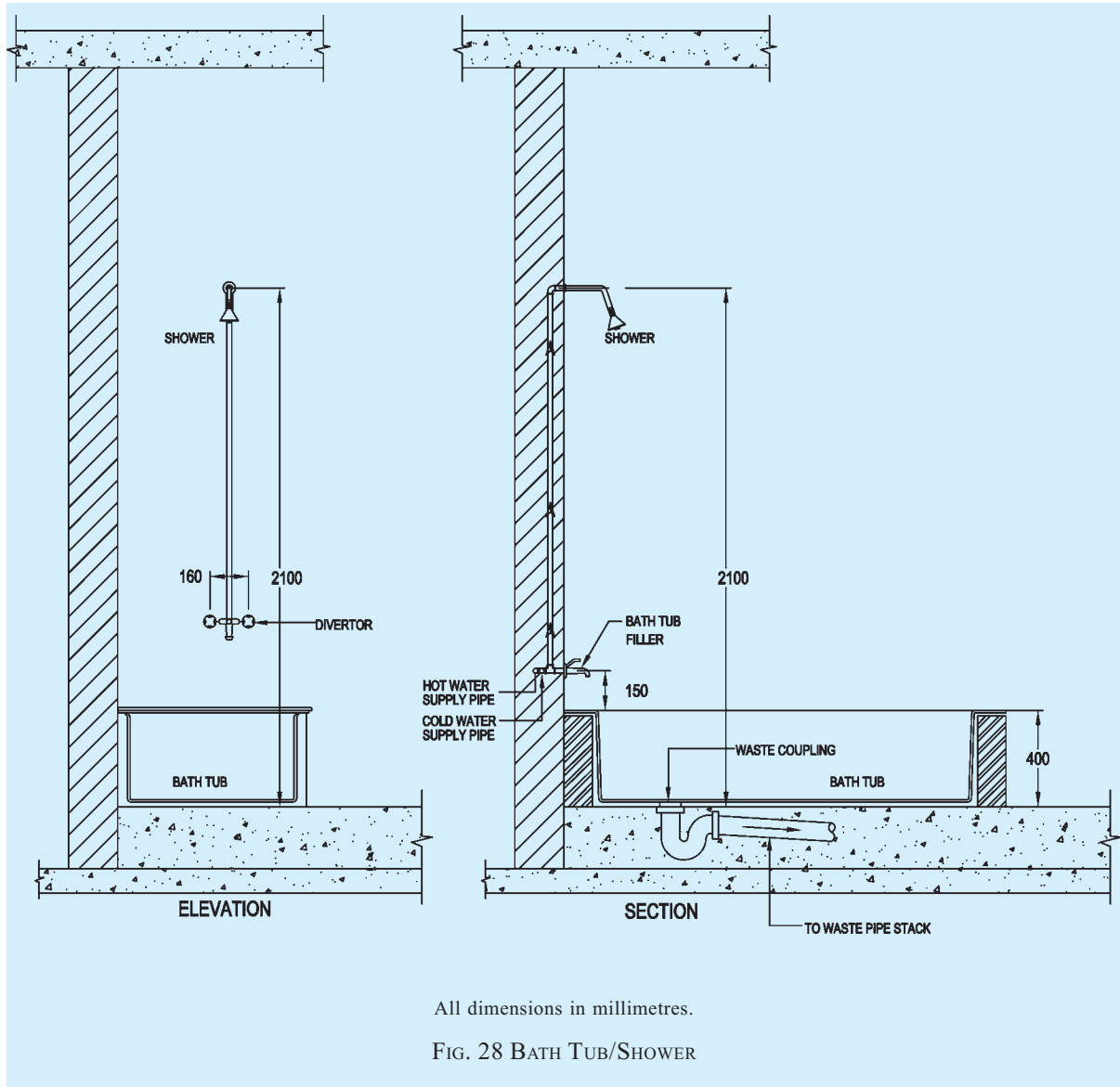

D-12 ARRANGEMENT FOR SHOWER AND ELECTRIC WATER HEATER (HORIZONTAL MOUNTED TYPE)

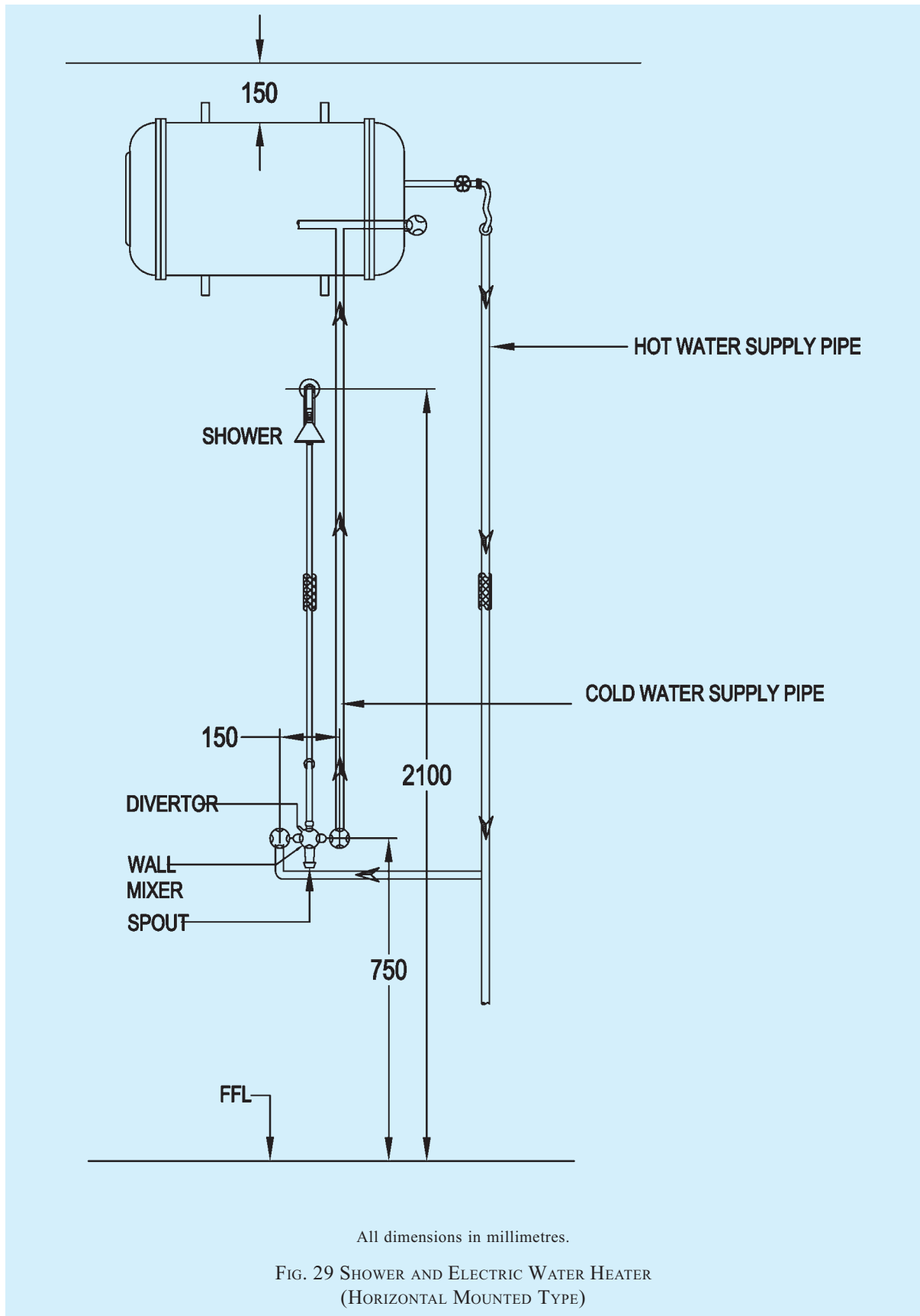

D-13 ARRANGEMENT FOR WASHING MACHINE

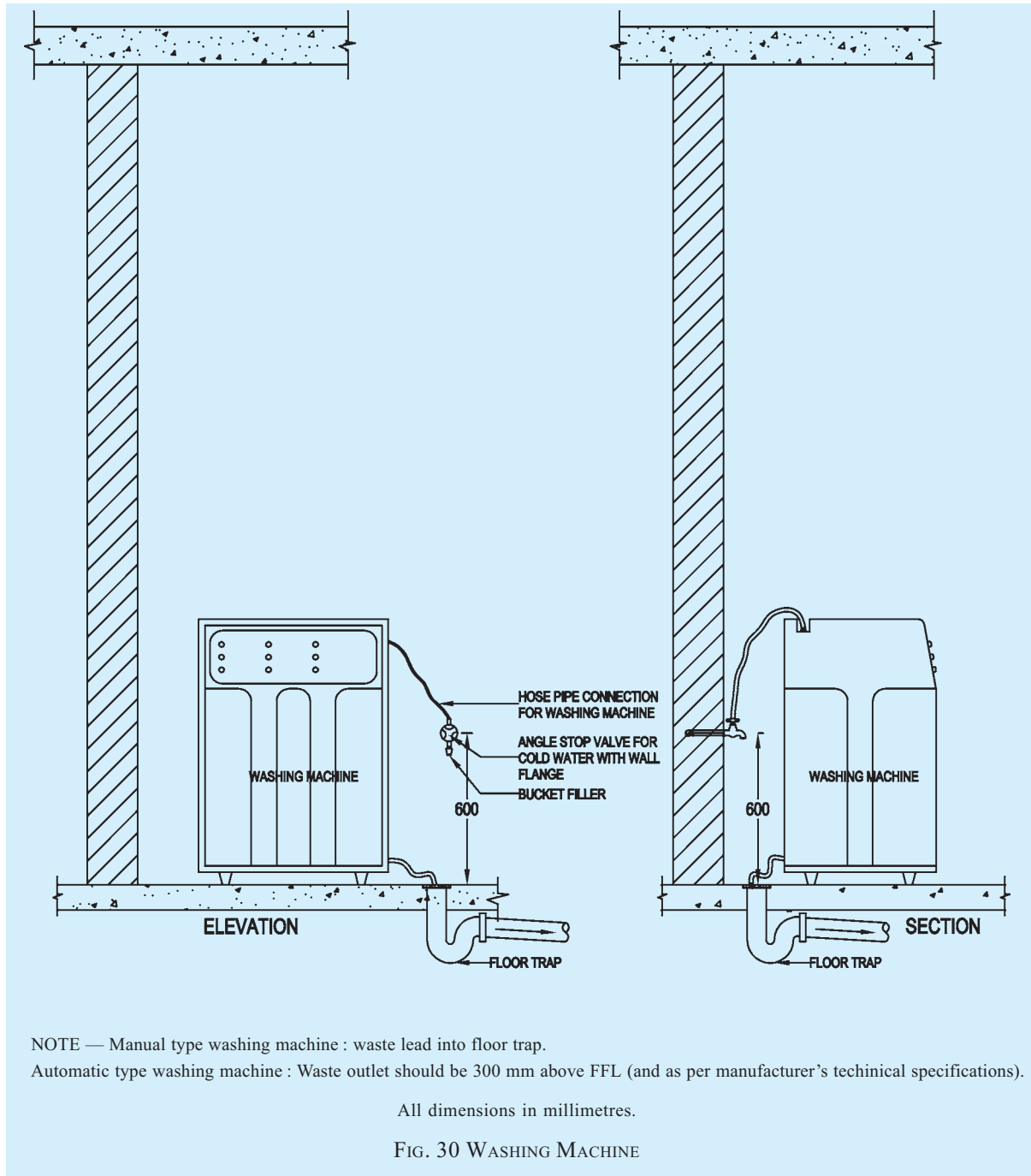

D-14 ARRANGEMENT FOR LPG PIPING

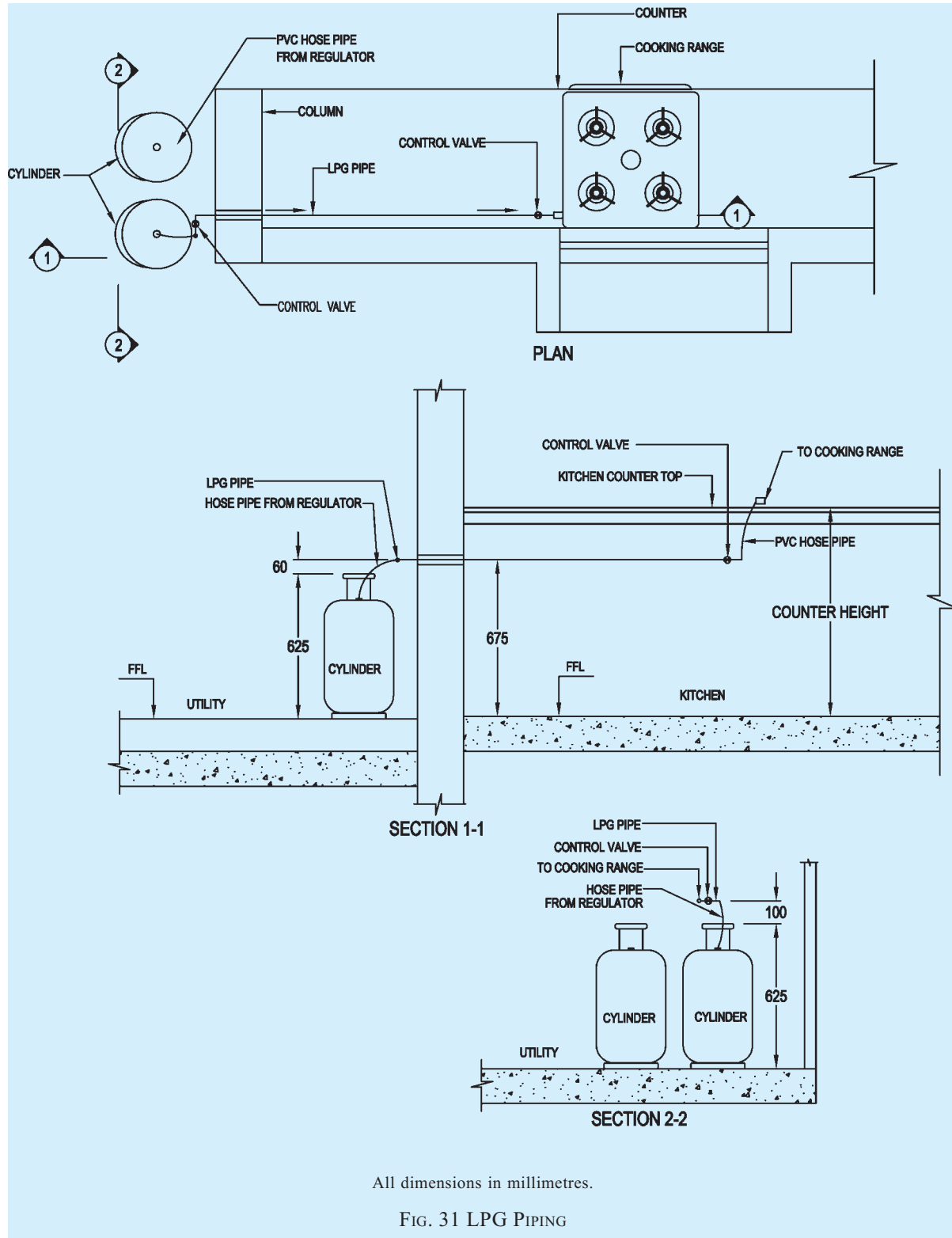

LIST OF STANDARDS

The following list records those standards which are acceptable as 'good practice' and 'accepted standards' in the fulfillment of the requirements of the code. The latest version of a standard shall be adopted at the time of enforcement of the code. The standards listed may be used by the Authority for conformance with the requirements of the referred clauses in the code.

In the following list, the number appearing in the first column with in parantheses indicates the number of reference in this Section:

<i>IS No.</i>	<i>Title</i>
(1) 10446 : 1983	Glossary of terms relating to water supply and sanitation
(2) 11208 : 1985	Guidelines for registration of plumbers
(3) 771	Specification for glazed fire-clay sanitary appliances
(Part 1) : 1979	General requirements (<i>second revision</i>)
(Part 2) : 1985	Specific requirements of kitchen and laboratory sinks (<i>third revision</i>)
(Part 3/Sec 1) : 1979	Specific requirements of urinals, Section 1 Slab urinals (<i>second revision</i>)
(Part 3/Sec 2) : 1985	Specific requirements of urinals, Section 2 Stall urinals (<i>third revision</i>)
(Part 4) : 1979	Specific requirements of postmortom slabs (<i>second revision</i>)
(Part 5) : 1979	Specific requirements of shower trays (<i>second revision</i>)
(Part 6) : 1979	Specific requirements of bed-pan sinks (<i>second revision</i>)
(Part 7) : 1981	Specific requirements of slop sinks (<i>second revision</i>)
772 : 1973	Specification for general requirements for enamelled cast iron sanitary appliances (<i>second revision</i>)
773 : 1988	Specification for enamelled cast iron water closets railway coaching stock type (<i>fourth revision</i>)
774 : 1984	Specification for flushing cistern for water closets and urinals (other than plastic cistern) (<i>fourth revision</i>)
775 : 1970	Specification for cast iron brackets and supports for wash basins and sinks (<i>second revision</i>)
1700 : 1973	Specification for drinking fountains (<i>first revision</i>)

<i>IS No.</i>	<i>Title</i>
2326 : 1987	Specification for automatic flushing cisterns for urinals (<i>second revision</i>)
2548	Specification for plastic seats and covers for water closets
(Part 1) : 1996	Thermoset seats and covers (<i>fifth revision</i>)
(Part 2) : 1996	Thermo plastic seats and covers (<i>fifth revision</i>)
2556	Specification for vitreous sanitary appliances (vitreous china)
(Part 1) : 1994	General requirements (<i>third revision</i>)
(Part 2) : 1994	Specific requirements of wash-down water closets (<i>fourth revision</i>)
(Part 3) : 1994	Specific requirements of squatting pans (<i>fourth revision</i>)
(Part 4) : 1994	Specific requirements of wash basins (<i>third revision</i>)
(Part 5) : 1994	Specific requirements of laboratory sinks (<i>third revision</i>)
(Part 6) : 1995	Specific requirements of urinals and partition plates (<i>fourth revision</i>)
(Part 7) : 1995	Specific requirements of accessories for sanitary appliances (<i>third revision</i>)
(Part 8) : 1995	Specific requirements of siphonic wash down water closets (<i>fourth revision</i>)
(Part 9) : 1995	Specific requirements of bidets (<i>fourth revision</i>)
(Part 14) : 1995	Specific requirements of integrated squatting pans (<i>first revision</i>)
(Part 15) : 1995	Specific requirements of universal water closets (<i>first revision</i>)
(Part 16) : 2002	Specific requirements for wash down wallmounted water closets
(Part 17) : 2001	Specific requirements for wall mounted bidets
3489 : 1985	Specification for enamelled steel bath tubs (<i>first revision</i>)
6411 : 1985	Specification for gel-coated glass fibre reinforced polyester resin bath tubs (<i>first revision</i>)
7231 : 1994	Specification for plastic flushing cisterns for water closets and urinals (<i>second revision</i>)

<i>IS No.</i>	<i>Title</i>	<i>IS No.</i>	<i>Title</i>
8718 : 1978	Specification for vitreous enamelled steel kitchen sinks		cement building pipes and pipe fittings, gutters and gutter fittings, and roofing fittings
8727 : 1978	Specification for vitreous enamelled steel wash basins	(Part 1) : 1994	Pipes and pipe fittings (<i>second revision</i>)
9076 : 1979	Specification for vitreous integrated squatting pans for marine use	(Part 2) : 1994	Gutters and gutter fittings (<i>second revision</i>)
11246 : 1992	Specification for glass fibre reinforced polyester resins (GRP) squatting pans (<i>first revision</i>)	(Part 3) : 1994	Roofing accessories (<i>second revision</i>)
13983 : 1994	Specification for stainless steel sinks for domestic purposes	6908 : 1991	Specification for asbestos cement pipes and fittings for sewerage and drainage (<i>first revision</i>)
(4) 651 : 1992	Specification for salt glazed stoneware pipes and fittings (<i>fifth revision</i>)	(8) 13592 : 2013	Specification for UPVC pipes for soil and waste discharge systems inside buildings including ventilation and rainwater system (<i>first revision</i>)
3006 : 1979	Specification for chemically resistant salt glazed stoneware pipes and fittings (<i>first revision</i>)	14333 : 1996	Specification for high density polyethylene pipe for sewerage
(5) 458 : 2003	Specification for precast concrete pipes (with and without reinforcement) (<i>fourth revision</i>)	14735 : 1999	Specification for unplasticized polyvinyl chloride (UPVC) injection moulded fittings for soil and waste discharge system for inside and outside buildings including ventilation and rainwater system
784 : 2001	Specification for prestressed concrete pipes (including specials) (<i>second revision</i>)	15328 : 2003	Unplasticized non-pressure polyvinyl chloride (PVC-U) pipes for use in underground drainage and sewerage systems
1916 : 1989	Specification for steel cylinder with concrete lining and coating (<i>first revision</i>)	(9) 2470	Code of practice for installation of septic tanks
4350 : 1967	Specification for concrete porous pipes for under drainage	(Part 1) : 1985	Design criteria and construction (<i>second revision</i>)
7319 : 1974	Specification for perforated concrete pipes	(Part 2) : 1985	Secondary treatment and disposal of septic tank effluent (<i>second revision</i>)
(6) 1536 : 2001	Specification for centrifugally cast (spun) iron pressure pipes for water, gas and sewage (<i>fourth revision</i>)	(10) 1536 : 2001	Specification for centrifugally cast (spun) iron pressure pipes for water, gas and sewage (<i>fourth revision</i>)
1537 : 1976	Specification for vertically cast iron pressure pipes for water, gas and sewage (<i>first revision</i>)	(11) 5329 : 1983	Code of practice for sanitary pipe work above ground for buildings (<i>first revision</i>)
1538 : 1993	Specification for cast iron fittings for pressure pipes for water, gas and sewage (<i>third revision</i>)	(12) SP 35 : 1987	Handbook on water supply and drainage with special emphasis on plumbing
3989 : 2009	Specification for centrifugally cast (spun) spigot and socket soil, waste ventilating and rainwater pipes, fittings and accessories (<i>third revision</i>)	(13) 2212 : 1991	Code of practice for brickwork (<i>first revision</i>)
7181 : 1986	Specification for horizontally cast iron double flanged pipes for water, gas and sewage (<i>first revision</i>)	(14) 5455 : 1969	Specification for cast iron steps for manholes
(7) 1592 : 2003	Specification for asbestos cement pressure pipes and joints (<i>fourth revision</i>)	(15) 1726 : 1991	Specification for cast iron manhole covers and frames (<i>third revision</i>)
1626	Specification for asbestos		

<i>IS No.</i>	<i>Title</i>	<i>IS No.</i>	<i>Title</i>
12592 : 2002	Specification for precast concrete manhole covers and frames (<i>first revision</i>)		rainwater gutters and downpipes for roof drainage (<i>first revision</i>)
(16) 4111(Part 1) : 1986	Code of practice for ancillary structures in sewerage system : Part 1 Manholes (<i>first revision</i>)	1729 : 2002	Cast iron/ductile iron drainage pipes and pipe fittings for over ground non-pressure pipeline socket and spigot series (<i>second revision</i>)
(17) 15792 : 2008	Guidelines for artificial recharge to ground water	1626 (Part 1) : 1994	Asbestos cement building pipes and pipe fittings, gutters and gutter fittings and roofing fittings: Part 1 Pipe and pipe fittings (<i>second revision</i>)
(18) 14961 : 2001	Guidelines for rainwater harvesting in hilly areas by roof water collection system	1239 (Part 1) : 2004	Steel tubes, tubulars and other wrought steel fittings: Part 1 Steel tubes (<i>sixth revision</i>)
15797 : 2008	Guidelines for roof top rainwater harvesting	13592 : 2013	Specification for UPVC pipes for soil and waste discharge systems inside buildings including ventilation and rainwater system (<i>first revision</i>)
(19) 783 : 1985	Code of practice for laying of concrete pipes (<i>first revision</i>)	(21) 2064 : 1993	Code of practice for selection, installation and maintenance of sanitary appliances (<i>second revision</i>)
1742 : 1983	Code of practice for building drainage (<i>second revision</i>)		
3114 : 1994	Code of practice for laying of cast iron pipes (<i>second revision</i>)		
4127 : 1983	Code of practice for laying of glazed stoneware pipes (<i>first revision</i>)		
6530 : 1972	Code of practice for laying of asbestos cement pressure pipes		
(20) 2527 : 1984	Code of practice for fixing		

NATIONAL BUILDING CODE OF INDIA

PART 9 PLUMBING SERVICES (INCLUDING SOLID WASTE MANAGEMENT)

Section 3 Solid Waste Management

BUREAU OF INDIAN STANDARDS

CONTENTS

FOREWORD	...	3
1 SCOPE	...	5
2 TERMINOLOGY	...	5
3 GENERAL	...	6
4 SOLID WASTE MANAGEMENT SYSTEMS	...	7
5 ASSESSMENT OF PER CAPITA WASTE QUANTITY	...	9
6 TREATMENT	...	10
ANNEX A MUNICIPAL SOLID WASTE GENERATION	...	12
ANNEX B TREATMENT OF FOOD WASTE	...	14
LIST OF STANDARDS	...	14

FOREWORD

This Code (Part 9/Section 3) covers the solid waste management systems, assessment of per capita solid waste quantities and treatment of solid waste within the building, building complexes and their built environments.

In the first version of the Code formulated in 1970, three separate sections of Part 9 Plumbing Services, were brought out, namely, Section 1 Water Supply, Section 2 Drainage and Sanitation, and Section 3 Gas Supply. These sections were subsequently revised in 1983 and in 2005.

In the second revision in 2005, the Part 9 was renamed as 'Plumbing Services (Including Solid Waste Management)' and provisions on solid waste management were included for the first time under Section 1 which contained in it, Water Supply, Drainage and Sanitation. Gas Supply was covered in Section 2 of Part 9 of the Code.

In this revision, to comprehensively address the various and distinct features related to the plumbing aspects, this Part 9 has been rearranged as follows:

- Section 1 Water supply
- Section 2 Drainage and sanitation
- Section 3 Solid waste management
- Section 4 Gas supply

Based on the experience gained in the use of the provisions on solid waste management included in last version, the provisions have been modified under this new Section. The significant changes include the following:

- a) Certain new terminologies have been included.
- b) References to latest applicable statutory Rules and Regulations have been included.
- c) Provisions related to solid waste management systems have been elaborated.
- d) Accessibility provisions for persons with disabilities to enable efficient operation of refuse chutes, have been included.
- e) Electrically operated dumb-waiters have been recommended for new construction having 5 storeys and above, from the erstwhile 8 storeys.
- f) New clause on assessment of per capita waste quantity has been included.
- g) Detailed provisions suggesting treatment methods have been included.
- h) An informative Annex A relating to municipal solid waste generation has been included, covering quantity, type, description and sources of solid waste generation.
- j) An Annex B relating to treatment of food waste has been included.

Reference may also be made to the Manual on Solid Waste Management, 2000, CPHEEO, Ministry of Urban Development, Government of India.

All Indian Standards, cross-referred to in the main text of this Section, are subject to revision. The parties to agreement based on this Section are encouraged to investigate the possibility of applying the most recent editions of the standards.

For the purpose of deciding whether a particular requirement of this Section is complied with, the final value, observed or calculated, expressing the result of a test or analysis, shall be rounded off in accordance with IS 2 : 1960 'Rules for rounding off numerical values (*revised*)'. The number of significant places retained in the rounded off value should be the same as that of the specified value in this Section.

NATIONAL BUILDING CODE OF INDIA

PART 9 PLUMBING SERVICES (INCLUDING SOLID WASTE MANAGEMENT)

Section 3 Solid Waste Management

1 SCOPE

This Code (Part 9/Section 3) covers the solid waste management systems, assessment of per capita solid waste quantities and treatment of solid waste within the building, building complexes and their built environments.

2 TERMINOLOGY

For the purpose of this Section, the following definitions shall apply, and for other terms those given in the accepted standard [9-3(1)] shall apply.

2.1 Anaerobic Digestion — A controlled process involving microbial decomposition of organic matter in the absence of oxygen.

2.2 Authorization — The consent given by the State Pollution Control Board or Pollution Control Committee, as the case may be, to the operator of a facility.

2.3 Biodegradable Substance — A substance that can be degraded by microorganisms into simpler stable compounds.

2.4 Biomethanation — A process which entails enzymatic decomposition of the organic matter by microbial action to produce methane rich biogas.

2.5 Collection — Lifting and removal of solid wastes from collection points or any other location.

2.6 Composting — A controlled process involving microbial decomposition of organic matter.

2.7 Construction and Demolition Waste — Wastes from building materials debris and rubble resulting from construction, re-modelling, repair and demolition operation.

2.8 Disposal — Final disposal of municipal solid wastes in accordance with the specified measures to prevent contamination of groundwater, surface water and ambient air quality.

2.9 Generator of Wastes — Persons or establishments generating municipal solid wastes.

2.10 Landfilling — Disposal of residual solid wastes on land in a facility designed with protective measures against pollution of groundwater, surface water and air fugitive dust, wind-blown litter, bad odour, fire hazard, bird menace, pests or rodents, greenhouse gas

emissions, slope instability and erosion.

2.11 Leachate — Liquid that seeps through solid wastes or other medium and has extracts of dissolved or suspended material from it.

2.12 Municipal Authority — Municipal Corporation, Municipality, Nagar Palika, Nagar Nigam, Nagar Panchayat, Municipal Council including notified area committee (NAC) or any other local body constituted under the relevant statutes and, where the management and handling of municipal solid waste is entrusted to such agency.

2.13 Municipal Solid Waste — Commercial and residential wastes generated in municipal or notified areas in either solid or semi-solid form, excluding industrial hazardous wastes and construction and demolition waste but including treated bio-medical wastes.

2.14 Operator of a Facility — A person who owns or operates a facility for collection, segregation, storage, transportation, processing and disposal of municipal solid wastes and also includes any other agency appointed as such by the municipal authority for the management and handling of municipal solid wastes in the respective areas.

2.15 Pelletization — A process whereby pellet are prepared which are small cubes or cylindrical pieces made out of solid wastes and includes fuel pellets which are also referred as refuse derived fuel.

2.16 Processing — The process by which solid wastes are transformed into new or recycled products.

2.17 Recycling — The process of transforming segregated solid wastes into raw materials for producing new products, which may or may not be similar to the original products.

2.18 Segregation — To separate the municipal solid wastes into the groups of organic, inorganic, recyclables and hazardous wastes.

2.19 Storage — The temporary containment of municipal solid wastes in a manner so as to prevent littering, attraction to vectors, stray animals and excessive foul odour.

2.20 Transportation — Conveyance of municipal solid wastes from place to place hygienically through

specially designed transport system so as to prevent foul odour, littering, unsightly conditions and accessibility to vectors.

2.21 Vermi-composting — A process of using earthworms for conversion of biodegradable wastes into compost.

3 GENERAL

3.1 Solid waste is generated from various human activities and which is normally disposed as useless and unwanted. Broadly, depending upon the type of building and built environment, it includes solid or semi-solid domestic waste, such as sanitary waste, commercial waste, office waste, catering and market waste and other non-residential wastes, street sweepings, silt removed or collected from the surface drains, horticulture waste, construction and demolition waste, and treated bio-medical waste. Further, there may be industrial hazardous waste, bio-medical waste and e-waste.

The primary objective of solid waste management is to collect, treat and dispose of solid wastes in an environmentally and socially satisfactory manner using the most economical means available. Ideally, solid waste should not contain faecal matter or urine but despite all precautions, some pathogens and chemical residues inevitably may be present in the waste. Uncontrolled or poorly managed intermediate decomposition of organic components of solid waste can contaminate air, water and soil resources. Implementation of integrated solid waste management practices benefits substantially, both the public health and the quality of the environment.

3.2 Based on source of generation, solid waste can be broadly categorized as follows:

- a) *Domestic waste* — It is generated in residential units; and consists of food wastes, paper, cardboard, plastics, textiles, leather, yard wastes, wood, glass, metals, ashes, special wastes (for example, bulky items, consumer electronics, white goods, batteries, oil and tyres), and household hazardous wastes.
- b) *Industrial waste* — It is generated in manufacturing units, fabrication plants, construction sites, power and chemical plants; and consists of packaging, hazardous wastes, ashes, special wastes, wood, steel, concrete, dirt, etc.
- c) *Institutional and commercial waste* — It is generated in schools, hospitals, prisons, government centres, stores, hotels, restaurants, markets, office buildings, etc; and consists of domestic wastes, paper, cardboard, plastics,

wood, glass, metals, special wastes and hazardous wastes.

- d) *Horticulture waste* — It is generated in landscaping, parks, orchards, dairies, and consists of street sweepings; landscape and tree trimmings; etc.

3.3 Based on suitability for handling and disposal, solid waste can also be categorized as follows:

- a) *Garbage* — Garbage is the term applied to animal and vegetable waste resulting from the handling, storage, sale, cooking and serving food. Such wastes contain putrescible organic matter, which produces strong odours and therefore attracts rats, flies and other vermin. It requires immediate attention in its storage, handling and disposal.
- b) *Municipal waste* — Municipal waste includes waste resulting from municipal activities and services such as street wastes, dead animals, market wastes and abandoned vehicles. However, the term is commonly applied in a wider sense to incorporate domestic wastes and commercial wastes.
- c) *Hazardous wastes* — Hazardous wastes may be defined as wastes of industrial, institutional or consumer origin which because of their physical, chemical or biological characteristics are potentially dangerous to human and the environment. It includes any waste that exhibits one of the hazardous characteristics, such as ignitability, corrosivity, reactivity, or toxicity, whether alone or when in contact with other wastes or substances. In some cases although the active agents may be liquid or gaseous, they are classified as solid waste because they are confined in solid containers. Typical examples are solvents, paints and pesticides whose spent containers are frequently mixed with municipal wastes. Good waste management should ensure that hazardous wastes are stored, collected, transported and disposed of separately, preferably after suitable treatment to render them innocuous.
A sub-category of household hazardous waste, is post-consumer utilization waste which qualifies as hazardous waste when discarded. It includes household chemicals and other consumer products used in home care, personal care, automotive care, pest control, etc. These products exhibit characteristics of reactivity, ignitability, corrosivity, toxicity, or persistence
- d) *Bio-medical waste* — Bio-medical waste is

any waste, which is generated during the diagnosis, treatment or immunization of human beings or animals or in research activities pertaining thereto or in the production or testing of biologicals. This waste is highly infectious and can be a serious threat to human health if not managed in a scientific and discriminate manner. It may include wastes like sharps, soiled waste, disposables, anatomical waste, cultures, discarded medicines, chemical wastes, etc. It has been estimated that hospitals generate bio-medical waste at a rate of 1 kg per bed day. Generally these wastes are handed over to common bio-medical treatment and disposal facilities for suitable treatment and final disposal.

Biological means any preparation made from organisms or microorganisms or product of metabolism and biochemical reactions intended for use in the diagnosis, immunization or the treatment of human beings or animals or in research activities pertaining thereto.

Bio-medical waste treatment facility means any facility wherein treatment, disposal of bio-medical waste or processes incidental to such treatment and disposal is carried out, and includes common treatment facilities. The common bio-medical treatment facilities are set up based on the need for ensuring environmentally sound management of bio-medical waste keeping in view the techno-economic feasibility and viable operation of the facility with minimal impacts on human health and environment.

All healthcare establishments including hospitals, research facilities and laboratories generate solid waste in course of performing their intended functions. 75 to 90 percent of such solid waste is non-risk healthcare waste, comparable to domestic waste. It requires minimal treatment and is safely handled by housekeeping staff. The remaining 10 to 25 percent of healthcare waste is designated as bio-hazardous waste and is designated bio-medical waste. It carries a variety of health risks in its handling and disposal. It is handled by trained staff and many safety devices and apparels are deployed. In addition, bio-medical waste includes the waste originating from minor or scattered sources, such as that produced in the course of healthcare undertaken in the home (dialysis, insulin injections, etc).

- e) *Plastics* — Plastics, due to their non-biodegradable nature, versatility in use and impact on environment, can be grouped under a different category of solid waste. More than 50 percent of the plastic waste generated in our country is recycled and used in the manufacture of various plastic products. Careless disposal of plastic in various forms chokes drains, blocks the porosity of the soil, causes problems for groundwater recharge, disturbs the soil microbe activity, contaminates foodstuff and when ingested by animals, it can kill them.

3.4 Efficient collection and disposal of domestic garbage from a building or activity area is of significant importance to public health and environmental sanitation and, therefore, an essential part of the built environment. Notwithstanding the provisions given herein, the solid waste management shall have to comply with relevant statutory Rules and Regulations in force from time-to-time. The provisions of the following shall govern the procedures for handling, treatment, etc, of solid wastes as applicable to the concerned building occupancy:

- a) *The Environment (Protection) Act*, 1986.
- b) *The Solid Waste Management Rules*, 2016.
- c) *The Bio-Medical Waste Management Rules*, 2016.
- d) *The E-Waste (Management) Rules*, 2016.
- e) *The Batteries (Management and Handling) Rules*, 2001.
- f) *The Hazardous and Other Wastes (Management and Transboundary Movement) Rules*, 2016.
- g) *The Plastics Waste Management Rules*, 2016.

NOTE — Radioactive wastes are covered under the provisions of *The Atomic Energy Act*, 1962 and rules made thereunder and the enforcement agency for these is Atomic Energy Regulatory Commission (AERC).

3.5 The provisions relating to solid waste management given in 4 are applicable to municipal solid waste and specifically exclude the hazardous chemical wastes, bio-medical waste and radioactive waste.

4 SOLID WASTE MANAGEMENT SYSTEMS

4.1 In designing a system dealing with collection of domestic garbage for a built premises/community/environment, the aim shall be to provide speedy and efficient conveyance as an essential objective for design of the system. The various available systems may be employed in accordance with 4.2 to 4.4, which may be adopted individually or in combination as appropriate in specific situations.

4.1.1 The basic stages of the municipal solid waste management system include the following:

- a) Waste sorting at source, collection and transportation;
- b) Resource recovery through centralized sorting and recycling;
- c) Resource recovery through waste processing, that is, recovery of energy; and
- d) Waste transformation without recovery.

4.1.2 The functional elements of municipal solid waste management system include the following:

- a) *Waste generation* — Activity in which the waste gets generated as material no longer having any value.
- b) *Waste handling, sorting, storage and processing at site* — Waste handling and sorting involves the activities associated with management of waste until they are placed in storage container for collection.
- c) *Collection* — Gathering of solid wastes including transportation.
- d) *Transfer and transport* — Transfer of waste from smaller collection vehicle to larger transport equipment and subsequent transport of wastes over long distances to a processing or disposal site.

4.2 Sorting at Source

Sorting shall be planned based on the existing markets for recyclable materials. It is preferable to have coloured-bin system based on the usage of the facility and the types of the waste likely to be generated in the facility (such as red, green, blue, yellow).

Common sorting methods involve sorting into,

- a) dry recyclable materials, for example, glass, paper, plastics, metals, etc;
- b) bio-waste and garden waste;
- c) bulky waste;
- d) hazardous material in household waste;
- e) construction and demolition waste; and
- f) mingled MSW (mixed waste).

In case of sorting not done at source, it is required to plan centralized sorting. The types of sorting that may be adopted, are:

- 1) Hand sorting from a raised picking belt.
- 2) Mechanized sorting facilities using magnetic and electric field separation, density separation, etc.

Sorting at source normally recovers most of the recyclable materials for reuse. However, a small

fraction of such materials may escape the sorting process. Sorting may therefore be also undertaken just prior to waste processing, waste transformation or landfilling to recover such recyclable materials.

Wherever manual sorting is adopted, care shall be taken to ensure that sorters are protected from all disease pathways and work in hygienic conditions. The movement of waste shall be planned by suitable mechanism and building shall be planned for easy movement of waste by means of garbage/material lift, ramps, etc, meeting the good engineering practices.

4.3 Refuse Chute System

4.3.1 General

Refuse chute system is a convenient and safe mode of transportation and collection of domestic solid wastes from buildings exceeding 5 storeys from floors at different heights. The refuse is received from the successive floor through the inlets located on the vertical system of pipes that convey refuse through it and discharge it into the collecting chamber, located at ground level, from where the refuse is cleared at suitable intervals. This system has got four functionally important components, namely, the chutes, the inlet hopper, the collection chamber and the cleaning and disinfecting arrangements.

The chute may be carried through service shafts meant for carrying drainage pipes. However, the location shall be mostly determined by the position of the inlet hopper and the collecting chamber that is most convenient for the user. It should also be considered to locate the chute away from living rooms in order to avoid noise and smell nuisance. The internal diameter of the chute shall be at least 300 mm.

In individual chute system, the inlet hopper shall be located in the passage near the kitchen and in the common chute system towards the end of the common passage. Natural ventilation should be adequate to prevent any possible odour nuisance. There should be adequate lighting at this location. For ground floor (floor 1), the inlet hoppers may be placed at a higher level, but should be easily accessible. The access to the refuse chute shall be provided from well ventilated and well illuminated common corridor or lobby and preferably it should not be located opposite or adjacent to entry of individual flats or lift.

4.3.2 Opening for Feeding of Refuse Chute

Opening, with top or bottom hinged shutters with appropriate lockable latch, shall be provided for convenient accessing of the refuse chute by users. It facilitates total building garbage collection at one single point and provides separate collection for dry and wet garbage. Chute system shall have the following features:

- a) Sanitation system for internal cleaning of chutes, with sprinklers at every floor intake level, with disinfectant cleaning, which may preferably be automatic in operation;
- b) Exhaust system with 25 to 35 air changes per hour;
- c) Discharge end fire resistant door;
- d) Chute may be of masonry, R.C.C. pipe, asbestos cement pipe or suitable non-corrosive material, preferably stainless steel. It should be rigid with smooth internal finish, high ductility and alkali/acid resistant properties {see also good practice [9-3(2)]};
- e) Fire rating shall comply with 3.4.8.3 of Part 4 'Fire and Life Safety' of the Code;
- f) Fire sprinklers shall be provided inside chute;
- g) Vent shall be installed at roof level to remove foul smell and gases generated;
- h) Chute should discharge to trolley directly;
- j) Necessary automation of the system may be planned to avoid malfunction by manual operation; and
- k) All care shall be taken for ensuring accessibility to the chute for persons with disabilities. The opening of the chute shall not be higher than 700 mm and there shall be a clear space of minimum 1 500 mm × 1 500 mm in front of the chute opening to gain easy access even for persons using wheelchairs. There may be high colour contrast provided around the chute opening to make it easy to identify it. The flooring in front of the chute opening may be texturally highly different from the rest of the floor.

4.3.3 Refuse Collection Chamber

The collection chamber may be located in ground floor or basement level, provided appropriate arrangement is made for drainage of the collection pit by gravity flow to ensure its dryness, an appropriate ramp access is provided for convenient removal of garbage from the collection pit, and satisfactory ventilation is provided for escape of gas and odour.

The floor of the chamber shall be provided with drainage through a 100 mm diameter trap and screen to prevent any solid matters flowing into the drain and the drain shall be connected to the sewer line. The floor shall be finished with smooth hard surface for convenient cleaning.

The height of the collection chamber and vertical clearance under the bottom level of garbage chute shall be such that the garbage trolley can be conveniently placed.

The collection chamber shall be provided with appropriate shutter to prevent access of scavenging animals like cattle, dogs, cats and rats.

4.3.4 Refuse Collection Room

The refuse collection room should be planned in ground or basement level with appropriate ventilation and proper drainage. The room should have access for vehicle or trolley transfer of garbage.

4.3.5 See also accepted standards [9-3(3)].

4.4 Dumb-Waiter or Service Lift

In high rise buildings with more than 5 storeys, electrically operated dumb-waiters may be used for carrying domestic garbage in packets or closed containers. For handling of garbage by dumb-waiters in a building, a garbage chamber shall have to be provided either at ground floor or basement level and the provisions of garbage collection chamber for chute as given in 4.3 shall apply.

5 ASSESSMENT OF PER CAPITA WASTE QUANTITY

5.1 For purposes of this Section, the following municipal refuse generation rates are recommended:

- a) Residential refuse : 0.3 to 0.6 kg/capita/day
- b) Commercial refuse : 0.1 to 0.2 kg/capita/day
- c) Street sweepings : 0.05 to 0.2 kg/capita/day
- d) Institutional refuse : 0.05 to 0.2 kg/capita/day

Out of the total solid waste generated, 40 percent may be taken as organic waste and 60 percent as inorganic waste. The knowledge of chemical characteristics of waste is important for selecting and designing the waste processing and disposal facilities.

5.2 These generation rates are subject to considerable site-specific factors and are required to be supported by field data. The waste contains a high percentage of ash and fine earth. The calorific value of Indian solid waste varies between 800 and 1 000 kcal/kg and the density varies between 300 and 500 kg/m³.

5.3 Other than municipal solid waste, the following types of waste may also be generated in urban centers:

- a) *Industrial waste* — Hazardous and non-hazardous waste from industrial areas within municipal limits.
- b) *Bio-medical waste* — Waste from hospitals, slaughter houses, etc.
- c) *Thermal power plant waste* — Fly ash from coal-based electricity generating plant within municipal limits.

- d) *Effluent treatment plant waste* — Sludge from sewage treatment plants and industrial effluent treatment plants.
- e) *Other wastes* — Special wastes from non-conforming areas or special units.

All waste streams shall be managed by their own waste management system.

6 TREATMENT

6.1 Garbage collected at one location may be treated for organic portion, and inorganic portion shall be handed over to vendors carrying out recycling. Organic waste generated in building/premises/community/environment may be treated and reused as manure. The norms prescribed by the pollution board authorities shall be followed, keeping hygiene and safe operation for the working/operating people.

Biological or thermal treatment of waste can result in recovery of useful products such as compost or energy.

6.2 Biological Processes

Biological treatment involves using microorganisms to decompose the biodegradable components of waste. The following two types of processes may be typically used, the former being used more commonly:

- a) *Aerobic processes* — It may comprise composting, aerated static pile composting and in-vessel composting; vermi-culture, etc. In the aerobic process the utilizable product is compost.
- b) *Anaerobic processes* — It may comprise low-solids anaerobic digestion (wet process), high solids anaerobic digestion (dry process) and combined processes. In the anaerobic process the utilizable product is methane gas (for energy recovery).

6.2.1 Composting

Decomposition and stabilization of organic waste matter is a natural phenomenon. Composting is an organized method of producing compost manure by adopting this natural phenomenon.

- a) *Manual composting* — It is an anaerobic method conventionally carried out in pits. Initially the waste is anaerobically stabilized in pits where alternate layers of solid waste and night soil are laid. The pit is completely filled and a final soil layer is laid to prevent fly breeding, entry of rain water into the pit and for conservation of the released energy. The material is allowed to decompose for 4 to 6 months after which the stabilized material is taken out and used as compost.

- b) *Mechanical composting* — Mechanical processes are preferred where higher labour costs and limitations of space exist. It is the process using a combination of aerobic and anaerobic decomposition in enclosed containers. Organic wet waste composter is used where raw refuse is composted in large vessel, which are turned at intervals by mobile pedals or plates. Several other processes have now been developed, using different methods of processing of solid waste, using different designs of digester.

Latest technology uses electrically operated rapid processing organic waste convertor with different capacities as mechanical composters. The organic wet and dry waste is separated and shredder is used to homogenize the materials and blenders are used under controlled temperature and bio-enzyme addition in closed containers. These output manure may be used for horticultural/agriculture works.

- c) *Vermi-composting* — Vermicompost treatment shall be provided to the organic wastes in composting pits located in shade. The pits shall be used to receive the garbage in a predetermined (periodic) cyclic order (for example, 5 pits to receive garbage in 5 days and these 5 pits together accepting daily load of garbage). The gross area of the composting pits may be about 0.1 m² per person.

The site for vermi-composting shall be enclosed from all sides with appropriate fencing (for keeping scavenging animals away) and provided with a small door for accessing the enclosed premises.

Composting pits shall be constructed either under the shade of trees (except Neem tree) or created under sheeting or shade-net, so as to keep the pits under shade. The pits shall be easily accessible for convenience of receiving of garbage through trolleys.

The composting pits shall be made in a manner that the pits do not have the risk of inundation by water. This may be achieved by appropriately raising the base level of the pit and providing weep holes from sides. Height of side walls of compost pits shall be 0.6 m to 0.75 m high. It is preferable to have the bottom of the pit without any lining.

Initiation of composting pits shall be done by providing a 75 mm thick layer of cow dung (fresh or partially decomposed), spreading 1 kg of vermi-compost and covering it with 75 mm to 100 mm thick layer of dry leaves/grass, etc, and sprinkling of water and allowing to decompose naturally for about 10 to 15 days.

Sorted garbage free from inert and toxic matters shall be applied in the composting pit in layers of 75 mm and spread, and covered with a layer of 75 mm thick dry leaves, followed by sprinkling of water.

The compost may be removed from the bottom of the compost pit after intervals of 3 to 6 months. The compost so made may be used in appropriate horticultural and related applications.

See also accepted standard [9-3(4)] for manure grade municipal solid waste compost.

6.3 Thermal Processes

Thermal treatment involves conversion of waste into gaseous, liquid and solid conversion products with concurrent or subsequent release of heat energy.

Three types of systems can be adopted, namely:

- a) *Combustion systems (Incinerators)* — Thermal processing with excess amounts of air.
- b) *Pyrolysis systems* — Thermal processing in complete absence of oxygen (low temperature).
- c) *Gasification systems* — Thermal processing with less amount of air (high temperature).

6.4 Land Filling

6.4.1 Disposal of waste on lands identified for the purpose is typical of this method of waste disposal. The depth of filling depends upon the site topography and location and varies from deep to shallow filling. A municipal solid waste landfill plant is an engineered facility used for disposal of solid waste. Landfills in which municipal waste is placed are designated as 'MSW landfills'. The main considerations in respect

of landfill sites are:

- a) Specifications for landfill sites,
- b) Site selection,
- c) Facilities at site, and
- d) Specification of land filling.

6.4.2 Improper landfill generally impacts the environment in the following ways:

- a) Groundwater contamination by the leachate generated by the waste dump;
- b) Surface water contamination by the run-off from the waste dump;
- c) Bad odour, pests, rodents and wind-blown litter in and around the waste dump;
- d) Generation of inflammable gas (for example, methane) within the waste dump;
- e) Bird menace above the waste dump which affects flight of aircraft;
- f) Fires within the waste dump;
- g) Erosion and stability problems relating to slopes of the waste dump;
- h) Epidemics through stray animals;
- j) Acidity to surrounding soil; and
- k) Release of greenhouse gas.

6.5 Some recycling/treatment methods for food waste are given in Annex B for guidance.

6.6 *See also* accepted standards [9-3(5)] for solid waste management, and for analysis and testing of solid wastes.

6.7 Other/special wastes shall be dealt with in accordance with the statutory provisions in respect of the same (*see 3.4*).

ANNEX A

(Foreword)

MUNICIPAL SOLID WASTE GENERATION

A-1 WASTE GENERATION

A-1.1 The typical type of wastes generated may be as follows:

Types of Solid Waste	Description	Sources
Food waste (garbage)	Wastes from the preparation, cooking, and serving of food. Market refuse, waste from the handling, storage, and sale of produce and meats and vegetable	Households, institutions and commercial such as hotels, stores, restaurants, markets, etc
Rubbish	a) <i>Combustible (primary organic)</i> — Paper, cardboard, cartons wood, boxes, plastics, rags, cloth, bedding, leather, rubber, grass, leaves, yard trimmings b) <i>Non-combustible (primary inorganic)</i> — Metals, tin cans, metal foils dirt, stones, bricks, ceramics, crockery, glass bottles, other mineral refuse	-do-
Ashes and residues	Residue from fires used for cooking and for heating buildings, cinders, clinkers, thermal power plants	-do-
Bulky waste	Large auto parts, tyres, stoves refrigerators, others large, appliances, furniture, large crates, trees, branches, palm fronts, stumps	-do-
Street waste	Street sweepings, dirt, leaves, catch basin dirt, animal droppings, contents of litter receptacles, dead animals	Streets, sidewalks, alleys, vacant lots, etc
Dead animals	a) <i>Small animals</i> — Cats, dogs, poultry, etc b) <i>Large animals</i> — Horses, cows, etc	-do-
Construction and demolition waste	Lumber, roofing and sheathing scraps, crop residues, rubble, broken concrete, plaster, conduit pipe, wire, insulation, etc	Construction and demolition sites, remodelling, repairing sites
Industrial waste and sludge	Solid wastes resulting from industry processes and manufacturing operations, such as food processing wastes and boiler House cinders, wood, plastic and metal scraps and shaving, etc. Effluent treatment plant sludge of industries and sewage treatment plant sledges, coarse screening, grit and septic tank	Factories, power plants, treatment plants, etc
Hazardous wastes	Pathological waste, explosives, radioactive material, toxic waste, etc	Households, hospitals, institution, stores, industry, etc
Horticulture wastes	Tree-trimmings, leaves, waste from parks and gardens, etc	Parks, gardens, roadside trees, etc

A-1.2 The typical quantity of waste generated measured per capita in urban areas may be as follows:

<i>Population Range (Million)</i>	<i>Average Per Capita Value (kg/capita/day)</i>
0.1-0.5	0.21
0.5-1.0	0.25
1.0-2.0	0.27
2.0-5.0	0.35
More than 5.0	0.50

A-2 INDUSTRIAL WASTE

The major generators are thermal power plants, integrated iron and steel mills, non-ferrous industries, pulp and paper industries and fertilizer and allied industries. Following are the source and quantum of generation of some major industrial wastes.

<i>Name of Industry</i>	<i>Quantity (Million tonne per annum)</i>
Steel and blast	35.0
Brine mud	0.02
Copper slag	0.016 4
Fly ash	30.0
Kiln dust	1.6
Lime sludge	3.0
Mica scraper waste	0.005
Phospho-gypsum	4.5
Red mud/Bauxite	3.0

A-3 SLAUGHTER HOUSE WASTE

Slaughtering of animals generates consisting of non-edible offal (lungs, large intestines, etc), stomach/intestinal contents, dung, sludge from waste water and bones, etc. These have to be disposed of by methods like rendering/controlled incineration/burial/composting/anaerobic digestion, etc. The estimated waste generation may be as per the following:

<i>Type of Slaughter House</i>	<i>Annual Capacity</i>	<i>Dry Waste Generated (tonne per day)</i>
Large	Large animals more than 40 000	6 to 7
	Small animals more than 600 000	
Medium	Large animals – 10 001 to 40 000	2 to 6
	Small animals – 100 001 to 600 000	
Small	Large animals up to 10 000	0.5 to 1.0
	Small animals up to 100 000	

A-4 BIO-MEDICAL WASTE

The waste generated from medical activities can be hazardous, toxic and even lethal because of their high potential for disease transmission.

The components of bio-medical waste include,

- a) human anatomical waste (tissues, organs, body parts, etc);
- b) animal waste (as above, generated during research/experimentation, from veterinary hospitals, etc);
- c) microbiology and biotechnology waste, such as, laboratory cultures, microorganisms, human and animal cell cultures, toxins, etc;
- d) waste sharps, such as hypodermic needles,

- e) syringes, scalpels, broken glass, etc;
- e) discarded medicines and cyto-toxic drugs;
- f) soiled waste, such as dressing, bandages, plaster casts, material contaminated with blood, etc;
- g) solid waste (disposable items like tubes, catheters, etc, excluding sharps);
- h) liquid waste generated from any of the infected areas;
- j) incineration ash; and
- k) chemical waste.

The estimated generation of total waste is 1.5 kg/bed and the estimated generation of bio-medical waste at 25 percent of total waste generation.

ANNEX B

(Foreword and Clause 6.5)

TREATMENT OF FOOD WASTE

B-1 FOOD WASTE

Food waste represents a large percentage of the solid waste. For establishments that serve food, there is an average of 400 g of food waste generated per meal served; when both pre-service and post-service waste is considered. The organic nature of food waste makes it unsuitable for disposal by landfills, though it is biodegradable.

In order to use the nutrient and calorific value of the food waste, it is collected, stored and then recycled. When collecting, it should be ensured that food waste does not enter the drainage system. When providing temporary storage, the risk of physical contamination of kitchen working areas should be avoided. It should be a separate ventilated room with 6 total air changes per hour. In hot climates, it shall be cooled to a temperature of 24°C to minimize odour generation. The storage area should be cleaned at least everyday.

A brief overview of some of the ways of food waste recycling/treatment is given in **B-2** to **B-4**. Before recycling/treatment, it requires non-organic materials to be removed from food waste.

B-2 FEEDING ANIMALS

Food discards can be made available for feeding animals. This may involve provisions for farmers, zoos and many other applications. Converting food discards to animal feed and pet food is common and a suitable option for recycling food scraps.

B-3 INDUSTRIAL USES

Food waste can be used in the rendering industry for

converting these materials to soaps, cosmetics and biodiesel fuel.

B-4 ANAEROBIC DIGESTION

This process involves breaking down organic matter in an oxygen-free environment in order to generate biogas, which is a combination of methane and carbon dioxide. The methane is burned for energy. The material that remains after digestion (digestate) should then be composted aerobically to complete the process and produce a valuable soil amendment.

Food waste drying system can provide a fast, simple and user friendly onsite process for decomposing and dehydrating food scraps into rich soil sediments. These systems do not require microorganisms, enzymes, fresh water or other additives.

Food cycler sterilizes, deodorizes and turns potentially harmful food scraps into safe, sterilized compost that can be reused as a soil amendment. It is a multi-phase, onsite organic food waste recycling machine that dehydrates and converts daily food waste into a sterile biomass. The sterilization process takes place at 82°C and reduces the waste volume by 85 to 93 percent. After sterilization, the food waste is converted into compostable humus-rich, high-carbon organic particles. The by-products of the process can be reused as soil amendment, compost accelerant, biofuels, animal feed, pet food, etc. Further benefits can be obtained by mixing the water produced from the food cycler units with potable or non-potable supplies to reduce the amount of water used from mains for use in gardens, landscaping and cooling towers.

LIST OF STANDARDS

The following list records those standards which are acceptable as 'good practice' and 'accepted standards' in the fulfillment of the requirements of the Code. The latest version of a standard shall be adopted at the time of enforcement of the Code. The standards listed may be used by the Authority for conformance with the requirements of the referred clauses in the code.

In the following list, the number appearing in the first column within parantheses indicates the number of the reference in this Section.

<i>IS No.</i>	<i>Title</i>
(1) 9569 : 1980	Glossary of terms relating to solid wastes
(2) 6924 : 1973	Code of practice for the construction of refuse chutes in multi-storeyed buildings
(3) 12402	Mobile containers for solid waste:
	(Part 1) : 1988 General characteristics
	(Part 2) : 1988 Methods of test

<i>IS No.</i>	<i>Title</i>	<i>IS No.</i>	<i>Title</i>
12647 : 1989	Guidelines for solid waste management system — Collection equipment		microbiological analysis
12662	Guidelines for use of vehicles for collection of municipal solid wastes:	9235 : 1979	Physical analysis and determination of moisture in solid wastes (Excluding industrial solid wastes)
(Part 1) : 1989	Selection of vehicles	10158 : 1982	Methods of analysis of solid wastes (Excluding industrial solid wastes)
(Part 2) : 2002	Guidelines for maintenance	16557 : 2016	Guidelines for solid waste management — Segregation, collection and utilization at household/community level
(4) 16556 : 2016	Specification for municipal solid waste compost, manure grade		
(5) 9234 : 1979	Methods for preparation of solid waste sample for chemical and		

NATIONAL BUILDING CODE OF INDIA

PART 9 PLUMBING SERVICES (INCLUDING SOLID WASTE MANAGEMENT)

Section 4 Gas Supply

BUREAU OF INDIAN STANDARDS

CONTENTS

FOREWORD	... 3
1 SCOPE	... 5
2 TERMINOLOGY	... 5
3 PRESSURE REGULATIONS	... 5
4 SERVICE SHUT-OFF VALVES	... 6
5 EXISTING WORK	... 6
6 RULES FOR TURNING GAS ON	... 6
7 RULES FOR SHUTTING OFF THE GAS	... 6
8 INSTALLATION OF GAS PIPES	... 7
9 INSPECTION OF SERVICES	... 8
10 LEAKAGE CHECK	... 9
11 USE OF LIQUEFIED PETROLEUM GAS (LPG)	... 9
12 USE OF PIPED NATURAL GAS (PNG)	... 14
13 USE OF MEDICAL GAS PIPELINE SYSTEM (MGPS)	... 16
LIST OF STANDARDS	... 17

FOREWORD

This Code (Part 9/Section 4) covers the safe use of gases for purposes like fuel, lighting and medical in buildings.

The use of gases for fuel and lighting purposes in buildings is becoming more and more common in different parts of the country, and with the advent of new petroleum complexes and piped gas system, community gas supply is bound to become one of the important services like electricity and water supply in buildings.

The use of liquefied petroleum gas supplied in containers and cylinders is already quite popular. On release of pressure, by opening the valve, they readily convert into the gaseous phase. In this state they present a hazard comparable to any inflammable natural or manufactured gas, except that being heavier than air, low level ventilation is necessary to avoid inflammable concentration of gas. Similarly, a series of precautions and regulations are necessary for laying of natural gas pipelines from city gas distribution entity to building premises and finally in the use location. Of late, the use of medical gases in hospitals through pipelines has become quite prevalent due to associated advantages; however, this needs to be supplemented with required care and precautions.

A minimum set of safety provisions are, therefore, laid down to safeguard the gas piping installation and the mode of operation in the interest of public safety.

In the first version of the Code formulated in 1970, three separate Sections of Part 9 Plumbing services, were brought out, namely, Section 1 Water supply, Section 2 Drainage and sanitation, and Section 3 Gas supply. These Sections were subsequently revised in 1983.

In the first revision, in 1983, the safe distance between gas piping and electrical wiring system was modified as well as between gas piping and steam piping was incorporated. Additional information regarding the handling, use, storage and transportation of LPG in cylinders exceeding 500 ml water capacity were included. Provisions relating to LPG cylinders, installations regarding some aspects, such as jointing compound used at joints, painting of gas piping, details of fire extinguishers, total quantity of LPG at stationary and portable installations in proportion to the floor area were added. Also, some provisions of LPG bulk storage installations were introduced.

In the second revision in 2005, the Part 9 was renamed as 'Plumbing Services (Including Solid Waste Management)' and provisions on solid waste management were included for the first time under Section 1 which contained in it, Water Supply, Drainage and Sanitation. Gas Supply was covered in Section 2 of Part 9 of the Code. In this second revision, provisions with regard to pressure regulations were modified; in the provision of service shut-off valves, number of additional shut-off valves were specified; in the provision of installation of gas pipe, new materials for pipes were mentioned; the minimum diameter for gas pipe was reduced to 8 mm; the colour for pipe line for supplying natural gas was specified; the provisions regarding protection against the corrosion were modified; the process of installation of meters were clarified; and additional method for detection of leakage of gas was recommended.

In this third revision of the Code, to comprehensively address the various and distinct features related to the plumbing aspects, this Part 9 has been rearranged as follows:

- Section 1 Water supply
- Section 2 Drainage and sanitation
- Section 3 Solid waste management
- Section 4 Gas supply

Based on the experience gained in the use of this Section, the provisions have been modified in this revision. The significant changes incorporated in this revision include the following:

- a) Certain terminologies have been included and others have been updated.
- b) Provision of use of fire stops/sleeves at openings has been included.

- c) Clause on use of use of liquefied petroleum gas has been completely revised.
- d) A new detailed clause on use of piped natural gas has been included.
- e) A new clause on medical gas pipeline system has been included.
- f) Cross-referred standards have been updated.

It may also be noted that the following Indian Standards have also been formulated on design and installation of natural gas pipelines:

IS 15663	Code of practice for design and installation of natural gas pipelines:
(Part 1) : 2006	Laying of pipelines
(Part 2) : 2006	Laying of pipelines in crossings
(Part 3) : 2006	Pre-commissioning and commissioning of pipelines

While implementing this standard, compliance with statutory regulations shall be ensured.

The information regarding the use of liquefied petroleum gas has been largely based on the following Indian Standards:

IS 6044	Liquefied petroleum gas storage installations — Code of practice:
(Part 1) : 2013	Residential, commercial and industrial cylinder installations (<i>second revision</i>)
(Part 2) : 2001	Commercial, industrial and domestic bulk storage installations (<i>first revision</i>)

All standards, whether given herein above or cross-referred to in the main text of this Section, are subject to revision. The parties to agreement based on this Section are encouraged to investigate the possibility of applying the most recent editions of the standards.

For the purpose of deciding whether a particular requirement of this Section is complied with, the final value, observed or calculated, expressing the result of a test or analysis, shall be rounded off in accordance with IS 2 : 1960 'Rules for rounding off numerical values (*revised*)'. The number of significant places retained in the rounded off value should be the same as that of the specified value in this Section.

NATIONAL BUILDING CODE OF INDIA

PART 9 PLUMBING SERVICES (INCLUDING SOLID WASTE MANAGEMENT)

Section 4 Gas Supply

1 SCOPE

1.1 This Code (Part 9/Section 4) covers the requirements regarding safety of persons and property for all piping uses and for all types of gases for purposes like fuel, lighting and medical in buildings.

1.2 This Section does not cover safety rules for gas burning appliances.

2 TERMINOLOGY

For the purpose of this Section, the following definitions shall apply.

2.1 Appliance Valve — A device that will shut-off the gas supply to the burner(s).

2.2 Approved Agency — Person or agency or a corporate body approved by competent authority or distribution company to execute the job of designing, erection and maintenance of multi cylinder installation.

2.3 Authority Having Jurisdiction — The Authority which has been created by a statute and which, for the purpose of administering the Code/Part, may authorize a committee or an official to act on its behalf; hereinafter called the 'Authority'.

2.4 Competent Authority — The Authority designated or otherwise recognized under *Gas Cylinder Rules, 2004* for approving LPG cylinders, valves and regulators.

2.5 Customer's/Consumer's Connection — Piping tapped on riser to supply each individual customer/consumer.

2.6 Distribution/Distributing Company — The company which is in the field of marketing LPG and PNG, and is the owner of LPG cylinders.

2.7 Gas Fitter — A qualified personnel of the authorized gas supplying organization.

2.8 Installation — A designated premises in an establishment where the complete multi-cylinder-system comprising cylinder, piping manifold, vaporizers, etc, is installed.

2.9 Manifold — A pipe header provided with several opening to which the cylinders are connected by using suitable pipe fittings.

2.10 Pilot — A small flame which is utilized to ignite the gas at the main burner(s).

2.11 Pressure Regulator — A device designed to lower the pressure of gas coming from the distribution main and to maintain it practically constants downstream. This normal operation pressure shall be practically in all cases that of the gas appliances used.

2.12 Purge — To free a gas conduit of air or gas or a mixture of gas and air.

2.13 Qualified Installing Agency — An individual, firm or agency which either in person or through a representative is engaged in and is responsible for the installation or replacement of gas piping on the outlet side of the gas meter, or the connection, installation or repair of gas supply piping and appliances within a building, and who is experienced in such work, familiar with all precautions required, and who has complied with all the requirements as to qualification, registration, licensing, etc, of the Authority.

2.14 Riser — Piping usually vertical on most of its length that supplies gas from the service to the various storeys of the building.

2.15 Service Pipe — Pipe that runs between the distribution main in the street and the riser in the case of multi-storeyed building or the meter in the case of an individual house.

2.16 Service Shut-Off Valve (Isolation Valve) — A device installed outside the premises to cut-off the main supply of gas from pipeline by the supplier.

2.17 Vent Pipe — A safety device to which certain regulators are connected to evacuate outside gas that may escape from the normal circuit when some part of system gets damaged or malfunctions or a safety valve is open.

3 PRESSURE REGULATIONS

3.1 Pressure regulation is required to economize the sizing of piping system. Where the pressure of gas supplied to domestic system or other low pressure gas piping system in buildings is in excess of the pressure to be used in the appliance, a gas pressure regulator of suitable specification shall be installed in service pipe of each system to prevent excess pressure reaching the appliance. The pressure regulators to be used can be from 400 kN/m² upstream pressure to 2.1 kN/m² for domestic consumers and 10 kN/m², 30 kN/m², 200 kN/m² for commercial consumers, as the case may be.

3.1.1 In some place the reduction of pressure from main

distribution source of 400 kN/m² to intermediate pressure (say 7 kN/m²) and then to operating pressure of 2.1 kN/m² is achieved.

3.1.2 Whereas in most of the other places the reduction of pressure from main distribution source of 400 kN/m² to directly operating pressure (say 2.1 kN/m², 10 kN/m², 30 kN/m², 200 kN/m²) is achieved in single stage pressure reduction.

3.2 If located inside a building, the required regulator shall comply with the following:

- a) If any of the diaphragms of the regulator ruptures, the gas shall be sent to an outlet vent pipe made of brass or plastic in order to ventilate or drain the gas out of the building. The vent pipe will, however, lead to outer air about 1 m above the topmost storey of the building. Means shall be employed to prevent water from entering this pipe and also to prevent stoppage of it by insects or other foreign bodies.
- b) If the gas pressure at the outlet of the regulator falls below 50 percent of the operating gas pressure or rises above twice the operating gas pressure, the gas input to the pressure regulator shall be cut off.
- c) In the event of malfunctioning of this safety device, a supplementary device shall connect the low pressure circuit to the outlet circuit (vent pipe) as soon as the exit pressure reaches 7 kN/m².

3.3 It shall also be ensured by the supply authority that the calorific value and supply pressure of gas shall not exceed the values for the type of gas used.

4 SERVICE SHUT-OFF VALVES

4.1 Service shut-off valves shall be installed on all new services including replacements in a readily accessible location.

4.2 Service shut-off valves shall be located upstream of the meter if there is no regulator or upstream of the regulator, if there is one.

4.2.1 Service shut-off valves shall be located in the upstream of the meter, if a single regulator is supplying more than one consumer and each such stream shall have one additional shut-off valve upstream of regulator.

4.3 All gas services operating at pressure greater than 7 kN/m² shall be equipped with an approved service shut-off valve located on the service pipe outside the building.

4.4 Underground shut-off valves shall be located in a covered durable curb box, manhole, vault or stand pipe

which is designed to permit ready operation of the valve and the covers of which shall be clearly marked 'Gas'.

5 EXISTING WORK

Nothing herein shall prohibit the continued use of existing system of the gas piping without further inspection or test, unless the Authority has reason to believe that defects which make the system dangerous to life or property exist.

6 RULES FOR TURNING GAS ON

6.1 No person, unless is the employ of the gas company or having permission from the gas company, shall turn on the gas at a service shut-off valve or at any valve that controls the supply of gas to more than one consumer.

6.2 Gas shall not be turned on at any meter valve without specific permission from the gas company or other authority if any of the following conditions exists:

- a) If the gas piping appliances or meter supply through the meter valve are known to leak or otherwise to be defective (*see 10*).
- b) If required inspection of the piping or appliance has not been made.
- c) If the gas company or other authority has requested that the gas be left turned off.
- d) If the meter valve is found shut-off for some reason not known to the gas fitter.

The gas shall not be turned on in the event of fire.

6.3 Gas shall not be turned on at any branch line valve if any of the conditions specified in **6.2** prevails. Where a branch line valve is found closed, a gas fitter shall again turn the gas on at such valve only if proper precautions to prevent leakage are taken and no other unsafe conditions are created thereby.

6.4 Gas shall not be turned on at either the meter valve or service line unless all gas keys or valves provided on all outlets in the piping system are closed or all outlets in the piping system are capped or plugged.

7 RULES FOR SHUTTING OFF THE GAS

7.1 The gas fitter shall put the gas off to any appliance, pipe or piping system and shall leave the gas turned off, until the causes for interrupting the supply has been removed in any one of the following cases:

- a) If ordered to do so by the Authority.
- b) If leakage of gas is noted, which appears to be sufficient to cause fire, explosion or asphyxiation.
- c) If an installation of some gas appliance is found to be such as to cause a serious hazard to persons or property.

- d) If any condition exists which threatens interruption of gas supply which may cause burner outage or otherwise prove dangerous.

7.2 It shall be the duty of the installing agency when the gas supply is to be turned off to notify all affected consumers.

7.3 Before turning off the gas at the meter, for the purpose of installation, repair, replacement or maintenance of piping or appliance, all burner and pilot valves on the premises supplied with gas through the meter shall be turned off and the meter test hand observed for a sufficient length of time to ascertain that there is no gas passing through the meter. Where there is more than one meter on the premises, precaution shall be exercised to ensure that the concerned meter is turned off.

8 INSTALLATION OF GAS PIPES

8.1 Installation, repair and replacement of gas piping or appliances shall be performed only by a qualified installing agency.

8.2 Piping

8.2.1 Piping shall be of wrought iron, steel, copper, stainless steel or cast iron when the gas pressure is less than 7 kN/m²; with higher gas pressure use of cast iron shall be prohibited.

8.2.1.1 SS 316/304/321 and flexible PE coated flexible pipe in rolls shall be permitted in low pressure system provided the pipe meets the required standard, to avoid the bends, fittings and leakages from the joint which are potential leakage points. Also, reference may be made to accepted standard [9-4(1)]. Heavy rubber flexible tube shall be permitted only as direct connection to burner from appliance valve.

8.2.1.2 For details regarding medical gas pipeline systems, a reference may be made to good practice [9-4(2)].

8.2.2 Size of Gas Piping

Gas piping shall be of such size and so installed as to provide supply of gas sufficient to meet the maximum demand without undue loss of pressure between the meter or service regulator when a meter is not provided, and the appliance(s).

8.2.2.1 The size of gas piping depends upon the following factors:

- a) Allowable loss in pressure from meter or service regulator, when a meter is not provided, to appliance;
- b) Maximum consumption to be provided;

- c) Length of piping and number of fittings; and
- d) Specific gravity of gas.

8.2.2.2 No gas pipe smaller than 8 mm shall be used.

8.2.3 As far as possible, straight lengths of piping should be used. Where there are bends in the pipe line, these should have a radius of at least five times the diameter of the pipe.

8.2.4 For any thread joint proper sealant shall be used on male threads only.

8.3 The gas piping shall be of the colour stipulated by explosive authority to distinguish it from other piping and the piping shall be painted silver grey with red band of 150 mm width. The gas pipeline shall be painted canary yellow in case of natural gas.

8.4 Piping Underground

8.4.1 Protection of Piping

Piping shall be buried to a minimum depth of 1 m or covered in a manner so as to protect the piping from physical damage.

8.4.2 Protection Against Corrosion

Generally all the piping within the premises where it has to run on the wall shall be exposed and should not be in contact with wall to ensure that no corrosion takes place. Epoxy sealant or polyethylene conduit shall be used to ensure no contact of pipe with the wall in the situation of pipe crossing the wall. Underground or concealed gas pipeline in contact with earth or other materials which may corrode the piping shall be protected against corrosion by application of adequate corrosion resistant coating backed up by cathodic protection system.

8.5 The building shall not be weakened by the installation of any gas piping.

8.6 Gas piping in building shall be supported with pipe hooks, metal pipe straps, bonds or hangers suitable for the size of piping and of adequate strength and quality and located at proper intervals so that the piping may not be moved accidentally from the installed position.

8.7 Pipe Entrance to Buildings

Where gas pipe enters a building through a wall or floor of masonry or concrete, any gas piping or other piping entering the walls or floors shall be suitably sealed against the entrance of water/moisture or gas.

The openings or imperfection of fit or design are also source of possible fire and smoke passing through them. Fire stops shall be provided to fill the openings around penetrating items such as gas pipes, etc, through the wall or floor openings. Non-combustible sleeving may

also be used as an alternative to proprietary seals for penetration of pipes of lead, aluminium, aluminium alloy, fibre cement or uPVC up to a specified nominal internal diameter. Proprietary fire stopping and sealing systems which have been shown by test to maintain the fire resistance of the wall or other elements, are available and may be used. Other fire stopping materials include cement mortar; gypsum-based plaster; cement or gypsum vermiculite/perlite mixes; glass fibre, crushed rock, blast furnace slag, or ceramic based products (with or without resin binders), and intumescent mastics. These may be used in situations appropriate to the particular material. Not all of them will be suitable in every situation. When sleeving is used, its length should be greater than the thickness of wall or floor. The sleeve shall be properly grouted to maintain fire/smoke separation.

Regarding protection of openings in walls or floors, from fire, reference shall be made to Part 4 'Fire and Life Safety' of the Code.

8.7.1 Piping in Floors

Piping in solid floors, such as concrete, shall be laid in channels in the floor suitably covered to permit access to the piping with a minimum damage to the building.

8.7.2 Single pipe without joint shall be used for wall crossing in any building.

8.8 Gas pipe shall not be bent. Fittings shall be used when making turns in gas pipe.

8.9 Generally concealed piping shall not be allowed. However, if it is necessary then it shall be under the **8.4** of underground piping and all protection such as coating, cathodic protection shall be done.

8.10 A drip shall be provided in the gas distribution system, if the moisture contents in the gas is likely to reach saturation point at any stretch of pipe line in the system; a drip shall, however, be provided at any suitable point in the line of the pipe where condensate may collect and from where it can be easily removed. This drip should be so installed as to constitute a trap where in an accumulation of condensate will shut-off the flow of gas before it will run back into the meter.

8.10.1 Drip has to be provided in the case of gas consisting moisture content.

8.11 Prohibited Devices

No device shall be placed inside the gas piping or fittings that will reduce the cross-sectional area or otherwise obstruct the free flow of gas.

8.12 Piping shall be electrically continuous throughout its length and properly earthed except in stretches where cathodic protection system is used for protection against

corrosion. It shall not, however, be used to earth any electrical equipment.

8.12.1 The distance between gas piping and electrical wiring system shall be at least 60 mm and, where necessary, they shall be securely fixed to prevent contact due to movement. The gas piping should run above the electrical wiring. In this type of installation in the event of any leakage of natural gas, the gas would move up (natural gas being lighter than air) and would not come directly in contact with the electrical wiring. If the gas to be supplied is heavier than the air then the gas piping should run below the electrical wiring.

8.13 The distance between the gas piping and steam piping, if running parallel, shall be at least 150 mm. The gas piping should preferably run below the steam piping.

8.14 Piping installation shall be thoroughly gastight.

8.15 Smoking shall not be permitted when working on piping which contains or has contaminated gas.

8.16 Meters shall be installed in such a way that there shall be no load transfer from the pipeline to the inlet/outlet of the meter and shall be easily accessible.

9 INSPECTION OF SERVICES

9.1 No person shall use or permit the use of a new system or an extension of an old system of gas piping in a building or structure before the same has been inspected and tested to ensure the tightness of the system, and a certificate has been issued by the Authority.

9.1.1 Test of Piping for Tightness

Before any system of gas piping is finally put in service, it shall be carefully tested to ensure that it is gastight. Where any part of the system is to be enclosed or concealed, this test should precede the work of closing in. To test for tightness the piping may be filled with city gas, air or inert gas but not with any other gas or liquid. In no case shall oxygen be used. The piping shall stand a pressure of at least 20 kN/m² measured with a manometer or slope gauge, for a period of not less than 10 min without showing any drop in pressure.

9.1.2 When the gas pressure exceeds 7 kN/m², the piping shall withstand a pressure of 0.6 MN/m² for 4 h (this test is for piping designed for working pressure less than 0.4 MN/m²).

9.2 The Authority shall, within a reasonable time after being requested to do so, inspect and test a system of gas piping that is ready for such inspection and test, and if the work is found satisfactory and test requirements are complied with, it shall issue the certificate.

10 LEAKAGE CHECK

10.1 Before turning gas under pressure into any piping, all openings from which gas may escape shall be closed.

10.2 Checking for Gas Leakage

No matches, flame or other sources of ignition shall be employed to check for gas leakage from meters, piping or appliances. Checking for gas leakage with soap and water solution is recommended.

10.3 Use of Lights

Artificial illumination used in connection with a search of gas leakage shall be restricted to electric hand flash lights (preferably of the safety type) or approved safety lamps. In searching for leaks, electric switches should not be operated. If electric lights are already turned on, they should not be turned off.

10.4 Checking for Leakage with Meter

Immediately after turning gas into the piping, the system shall be checked to ascertain that no gas is escaping. This may be done by carefully watching the test dial of the meter to determine whether gas is passing through the meter. In no case should a leakage test be made using a gas meter unless immediately prior to the test it has been determined that the meter is in operating condition.

10.5 Checking of Leakage Without Using a Meter

This may be done by attaching to an appliance, orifice or a manometer or equivalent device and momentarily turning on the gas supply and deservng the gauging device for pressure drop with the gas supply shut-off. No discernible drop in pressure shall occur during a period of 3 min.

10.6 After piping has been checked, all gas piping shall be fully purged. Piping shall not be purged into the combustion chamber of an appliance. A suggested method for purging the gas piping to an appliance is to disconnect the pilot piping at the outlet of the pilot valve.

10.7 After the gas piping has been effectively purged, all appliances shall be purged and the pilots lighted.

10.8 In addition to the checking of gas leakage with soap and water solution, a suitable gas detector is also recommended for use.

11 USE OF LIQUEFIED PETROLEUM GAS (LPG)

11.1 The cylinders used for the storage and transportation of liquefied petroleum gas (LPG) shall conform to accepted standards [9-4(3)] approved by the statutory authority.

11.2 The handing, use, storage and transportation of liquefied petroleum gas in cylinders exceeding 500 ml water capacity shall be done in accordance with good practice [9-4(4)].

11.3 LPG Cylinder Installation

The following recommendations apply to installation in commercial, industrial, educational and institutional premises.

11.3.1 General Recommendations

11.3.1.1 Those responsible for the installation of cylinders, equipment and piping should understand the characteristics of LPG and be trained in good practice of handling, installing and maintaining installations.

11.3.1.2 The jointing compound used at different joints in the system shall be decided by the Qualified Installing Agency. Hemp and similar materials shall not be used at the joint. In any joint in which the thread provides a gastight seal, jointing compound shall be used only on the male thread.

11.3.1.3 Fire extinguishers of dry powder type or carbon dioxide type conforming to accepted standards [9-4(5)] shall be provided in places where LPG cylinder installations are situated and shall be located near such installations. Two buckets filled with sand and two with water shall also be installed nearby. The number, type and size of the fire extinguishers shall be as follows:

	<i>Number</i>	<i>Type</i>	<i>Capacity</i>
a) For installations with LPG 40 kg to 200 kg	2	Dry powder	9 kg
b) For installations with LPG more than 200 kg and up to 320 kg	3	Dry powder	9 kg
c) For installations with LPG more than 320 kg and up to 1 000 kg	4	Dry powder	9 kg

NOTE — For electrical installations, one number CO₂ fire extinguisher (4.5 kg capacity) shall be provided.

11.3.1.4 Liquefied petroleum gas shall not be transferred from the cylinders in which it is received to any other container.

11.3.2 Cylinder Location

11.3.2.1 Stationary installations

- a) Stationary installation not exceeding 50 kg of LPG may be installed indoors on any floor. It is recommended to have a minimum floor area of 5 m² for such an installation.

- b) Stationary installations each not exceeding 50 kg of LPG may be installed indoors on any floor and within the same workspace provided the minimum distance between two such installations is 3 m, the proportion of such installations to floor area is one installation per 5 m² and the aggregate quantity of gas of all such installations does not exceed 200 kg.
- c) Stationary installation not exceeding 100 kg of LPG may be installed indoors on any floor provided the floor area for such an installation is not less than 12 m².
- d) Stationary installations each not exceeding 100 kg of LPG may be installed indoors on any floor and within the same workspace provided the minimum distance between two such installations is 3 m, the proportion of such installations to floor area is one installation per 12 m² and the aggregate quantity of gas of all such installations does not exceed 200 kg.
- e) Stationary installation not exceeding 400 kg of LPG may be installed indoors in an enclosed section of a building or a room reserved exclusively for this purpose and ventilated at low level directly to the outside air.
- f) Stationary installations above 400 kg [200 kg in case provision as in (e) is not possible] but not exceeding 1 000 kg shall be installed outdoors on ground floor level only. A minimum distance of 3 m shall be maintained between an installation and any building, public place, roadways, and other surroundings. The installation shall be protected from excessive weathering by sun, rain, etc, and from tampering by unauthorized persons. A lean-to roof with expanded metal on angle-iron framework on the sides is considered suitable for this purpose. In any case, adequate ventilation at ground level to the outside air shall be provided.
- g) If the storage per installation is more than 1 000 kg, installations in multiples of 1 000 kg with manifold, safety devices, change over mechanism may be provided with minimum inter distance of 3 m from all sides. Total number of such installations shall not exceed 4 including stand by installation. If more than two installations are used, then number of cylinders per installations should not exceed 30.
- h) For storage installations of 1 000 kg or installations in multiple of 1 000 kg the number of cylinders to be connected per manifold shall not exceed 15 and for each 1 000 kg installation two such manifolds shall be provided.
- j) Cylinders shall be installed upright with the valves uppermost.
- k) Cylinder containing more than 20 kg of gas shall not be located on floors above ground level.
- m) Cylinders shall be located on a concrete or brick floor, preferably raised in case of outdoor installations.
- n) In order to prevent the hazardous collection of gas, cylinders shall be placed at least 1 m away from culverts, depressions, or openings leading to below ground level compartment and drains.
- p) Cylinders which have safety relief valves or similar devices incorporated in them shall be so positioned so that if the relief device operates, escaping gas is not hazardous.
- q) Cylinder installation for commercial/ industrial/domestic/residential complexes, etc, or at any public place shall meet the following requirements:
- 1) For commercial and industrial cylinder installation for any public places like mall, buildings, industries, hotels, etc, the sum total of all stationery installations inside the building shall not exceed 400 kg of LPG in any case. In case sum total of net weight of all the cylinders installed indoors exceed 400 kg provision for outdoor installations shall be made. For installations where the sum total is less than 400 kg of LPG provisions of (b) to (e) shall apply.
 - 2) For commercial and industrial cylinder installation for any public place, industry, etc, if the net weight of all the cylinders installed is more than 400 kg but less than 1 000 kg, than the installation shall be provided outdoors in line with (f). The cylinder installation shall be provided in a covered industrial shed but open from all sides for proper ventilation. In case the installed capacity increases more than 1 000 kg, than the installation shall be provided in line with (g). Two separate installations shall be provided and distance between each of the installations shall be minimum 3 m (this distance shall be between the outer edge of the two sheds).
 - 3) For multi-storeyed buildings, flats housing society the reticulated installation of any capacity shall be provided at a safe

place especially earmarked for this purpose. The installation shall not be provided by the side of road where there is continuous movement of vehicles or is approachable to residents especially children. The installation should be secured and should be provided in a covered shed open from all sides for ventilation. The area shall be demarcated by 1.5 m high chain link fencing having one gate. There should be minimum 3 m clear space all around the fencing and the space between the fencing and the edge of the shed should be minimum 2 m all around.

- 4) If the requirement is more than 1 000 kg, installations in multiples of 1 000 kg with manifold, safety devices, change over mechanism, not exceeding 4 such installations (including stand by) may be provided with minimum distance of 3 m from all sides. The number of cylinders per installations should not exceed 30.
- 5) Location of cylinder bank:
 - i) The site for LPG cylinder manifold shall be located away from the kitchen/LPG utility area/residential building. Installation shall be slightly raised minimum 100 mm from surrounding ground level.
 - ii) Cylinders installation should not be located in inaccessible location, under a stairway, basements, cellars, where air movement across cylinders is very low/not present, to prevent the cylinders from getting inadequate latent heat and unapproachable during emergency.
 - iii) Cylinders installation should not be close to steam pipes, boilers, transformers, DG sets, etc, to prevent cylinders from getting affected due to radiant heat.
 - iv) Cylinders shall not be installed at a place where they are likely to cause obstruction, suffer damage or be exposed to conditions likely to affect safety.
 - v) Cylinders installation should not be located along the drive way. Under unavoidable conditions, minimum distance of 3 m from drive way shall be maintained. Brick masonry (minimum 230 mm thick)/concrete (minimum 100 mm thick) walls or

metallic shields/barriers (minimum 1.63 mm sheet) and of minimum 2 m height should be erected between drive way and cylinder installation for the safety and security of the installation.

- vi) Cylinders shall be located on a concrete or brick floor that is firm, at level, smooth, drained in case of outdoor installation.
 - vii) The cylinder shall be installed in upright position with the valve pointing upwards and minimum 1 m away from any combustible materials.
- r) Cylinder storage room:
- 1) The cylinder storage room shall be made out of non-flammable material that is concrete (minimum 100 mm thick) or brick masonry walls (minimum 230 mm thick) or steel structures made out of minimum 5 mm thick MS angle iron structure and 1.63 mm MS wire mesh of size minimum 11.
 - 2) Since LPG is heavier than air, ventilation shall be provided at floor level, that is 100 mm above inside cylinder bank room, open to atmosphere. The ventilators shall be provided with 2 layers copper or non-corroding metal wire mesh not less than 11 to the linear centimetre. The size of the ventilators should be minimum 500 mm long and 300 mm height.
 - 3) The storage room shall be well ventilated, that is openings/ventilators shall be provided in the walls of cylinder storage covering minimum 25 percent of wall area. It should also have adequate lighting. Both exteriors and interiors should be painted with weather proof paints. FLP fittings, approved by statutory authorities shall be provided for electrical use.
 - 4) The doors of the room where cylinders are installed shall open outwards and shall have louvers/wire mesh to ensure visibility and ventilation.
 - 5) Flammable materials like wood and plastic shall not be used. The cylinder bank storage room shall not used for storing any other materials.

11.3.2.2 Portable installations

When portability of cylinders is necessary, the following requirements shall be fulfilled:

- a) The sum total of capacity of the cylinders connected to each manifold shall not exceed 100 kg of LPG. The total quantity of gas thus installed in a workspace shall not exceed 200 kg.
- b) If cylinders are mounted on a trolley, the trolley shall be stable. Where necessary, the cylinders shall be secured to prevent them from falling.
- c) The regulator shall be connected directly to the cylinder valve or to a manifold which shall be connected to the cylinder valves by means of rigid connections to give adequate support to the regulator. The only exception to this requirement is where cylinders are mounted on a trolley and the manifold is rigidly supported on the trolley. In such a case flexible or semi-flexible connections may be used between the cylinder valves and the manifold but not between the manifold and the regulator.
- d) Anytime the total quantity of gas at portable installations shall be in proportion to the floor area as specified in 11.3.2.1 (a) to (f).
- e) At any time the provisions at 11.3.2.1 (a) to (r) shall be ensured for all installations.

11.3.3 Cylinder Manifolds

11.3.3.1 All materials, fittings, etc, used in cylinder manifold systems shall comply with the statutory provisions or relevant Indian Standards. In absence of any such provisions or Indian Standards, equivalent international norms shall be followed.

11.3.3.2 The individual component parts of manifolds, that is piping, fittings, pigtails, etc, which are subject to cylinder pressure shall be capable of withstanding a test pressure without bursting of 2.5 N/mm² or one and a half times the developed pressure at 65°C, whichever is more.

11.3.3.3 Where cylinder installations are made up with service and reserve batteries of cylinders, suitable change-over devices or valves shall be incorporated in the manifold header to prevent undue escape of the gas when cylinders are changed.

11.3.3.4 In case pressure regulators, manifold headers and automatic change-over devices are connected to cylinder by semi-flexible connectors, these shall be rigidly supported. Copper tube pigtails are considered to be semi-flexible for this purpose.

11.3.3.5 It is recommended that joints in manifold headers which do not have to be broken in normal use should be welded or brazed using a material which shall have a melting point of at least 540°C.

11.3.3.6 All joints between manifold headers and cylinder connectors shall be readily accessible.

11.3.3.7 All joints in the manifold should be welded (except for valve fixation) and be easily accessible for inspection/repairs, etc.

11.3.3.8 Each manifold arm shall be fabricated in such a way that minimum joints are provided. Only seamless pipes are recommended for use in manifolds. There should be a minimum gap of 300 mm between the manifold and valve protection ring of the LPG cylinders.

11.3.3.9 The cylinders connected to a manifold shall be safely spaced for easy and safe replacement of cylinder when empty. A minimum distance of 400 mm shall be maintained between two nipples provided on the manifold for connecting the cylinders to the manifold. In case the diameter of the cylinder is higher than 400 mm then the distance between the two nipples shall be diameter of the cylinder plus 100 mm.

11.3.3.10 A pressure gauge of 100 mm dial shall be provided in the manifold to indicate the gas pressure in the manifold. The pressure gauge shall be suitable for a pressure range 0 to 1.0 N/mm².

11.3.4 Pressure Regulators

11.3.4.1 Pressure regulators and other devices used to control the gas shall comply with the distributing company's stipulations and accepted standards [9-4(6)].

11.3.4.2 Pressure regulator fitted with a safety valve shall be either,

- a) installed in the open air; or
- b) vented to the open by means of a metal vent pipe connected to the safety valve outlet.

11.3.4.3 Care shall be taken that safety valve outlets do not become choked with dust or other foreign matter.

11.3.4.4 If the regulator is fitted with a relief valve, care should be taken in positioning the regulator to avoid unnecessary hazards if the relief valve functions.

11.3.4.5 Pressure regulators and other control devices shall be adequately supported.

11.3.5 Instructions to Consumers

Consumers shall be instructed by the distribution company on the following, through appropriate written instructions:

- a) Operation of the whole system;
- b) How to recognize gas leaks;
- c) Action to be taken in case of leakage;
- d) Action to be taken in case of fire; and
- e) Action to be taken in case of damage to, or failure of, any part of the installation.

11.3.6 For detailed information regarding installation of LPG cylinders in commercial, industrial, educational and institutional premises, reference may be made to good practice [9-4(7)].

11.4 LPG Bulk Storage Installations

The following recommendations apply to LPG bulk storage installations where storage tanks over 450 litre water capacity are used at industrial, commercial and domestic consumers’ premises.

The maximum capacity of an individual tank and group of tanks at industrial, commercial and domestic premises shall be as follows:

Premises	Maximum Water Capacity of an Individual Tank	Maximum Water Capacity of Group of Tanks
	ℓ	ℓ
Industrial	130 000	260 000
Commercial	40 000	80 000
Domestic	20 000	80 000

11.4.1 Location and Spacing of Storage Tanks

11.4.1.1 Storage tanks shall be located outside the buildings and shall not be installed one above the other.

11.4.1.2 Each individual tank shall be located with respect to the nearest important building or group of buildings or line of adjoining property which may be built in accordance with Table 1. The distances given refer to the horizontal distance in plan between the nearest point of the storage tank and building/property line.

11.4.1.3 In heavily populated or congested areas the

authority may determine the need for other reasonable protective methods to be taken, such as provision of fire walls, etc. If fire walls are to be provided, the authority may determine the extent to which the safety distances for above ground tanks may be reduced.

11.4.1.4 No LPG tank(s) shall be located within the bunded enclosures of any petroleum installation. The minimum distance of separation between LPG storage tanks and any petroleum installation shall be as prescribed under the *Petroleum Rules, 1976* or as specified in Table 1, whichever is more.

11.4.1.5 The number of storage tanks in one storage installation shall not exceed six. In case there are more than one storage installations, the safety distance between two installations shall be the same as the distance between the tanks and the property line in accordance with Table 1.

11.4.2 Bunding

Since LPG is heavier than air, storage tank shall not be enclosed within bund walls. The accumulation of flammable liquid under LPG tanks shall be prevented by suitably slopping the ground.

11.4.3 Protection

11.4.3.1 To prevent trespassing or tampering, the area which includes tanks, direct fired vapourisers, pumping equipment and loading and unloading facilities shall be enclosed by an industrial type fence at least 2 m high along the perimeter of the safety zone. Any fence shall have at least two means of exit. Gates shall open outwards and shall not be self-locking.

11.4.3.2 When damage to LPG systems from the LPG tank lorry is a possibility, precautions against such damage shall be taken.

Table 1 Minimum Safety Distances
(Clauses 11.4.1.2, 11.4.1.4 and 11.4.1.5)

Sl No.	LPG Storage Water Capacity of Individual Tank ℓ	Distance from Building/Property Line		Distance between Tanks	
		Above Ground m	Under Ground m	Above Ground m	Under Ground m
(1)	(2)	(3)	(4)	(5)	(6)
i)	Up to 2 000	5	5	1	1.5
ii)	Above 2 000 and up to 10 000	10	7.5	1	1.5
iii)	Above 10 000 and up to 20 000	15	10	1.5	1.5
iv)	Above 20 000 and up to 40 000 adjacent	20	15	2	0.25 × diameter of vessel or 1.5 m (Min)
v)	Above 40 000 and above adjacent	30	15	2	0.25 × diameter of vessel or 1.5 m (Min)

NOTE — If the aggregate water capacity of a multi-tank installation is 40 000 litre or greater, the above minimum safety distances shall apply to the aggregate storage capacity rather than the capacity per individual storage tank.

11.4.3.3 Underground tanks shall be protected from above ground loading by providing a suitable curb to prevent a possible accidental damage to the tank and its fittings by LPG tank lorry.

11.4.4 Grass and Weed Removal

Road ignitable material, such as weeds, long grass or any combustible material shall be removed from an area within 3 m from the shell of any LPG tank of up to 2 000 litre water capacity, and within 6 m from the shell of larger tanks. If weed killers are used, chemicals which are a potential source of fire hazard shall not be selected for this purpose.

11.4.5 Warning Signs

No smoking or naked flames shall be permitted within the safety zone of the installation. Prominent notices to this effect shall be posted at access point. From accessibility point of view, the signs shall be in accordance with 13 of Part 3 'Development Control Rules and General Building Requirements' of the Code.

11.4.6 Fire Protection

The possibility of a major fire outbreak, leading to direct flame impingement of the storage tank, shall be minimized by sound engineering in plant design and layout, good operating practice, and proper education and training of personnel on both routine operations and on action to be taken in an emergency.

11.4.6.1 Water supply

Provision shall be made for an adequate supply of water and fire protection in the storage area according to the local hoses and mobile equipment, fixed monitors or by fixed spray systems which may be automatic. Control of water flow should be possible from outside any danger area.

11.4.6.2 Fire extinguishers

At least two dry chemical powder type fire extinguishers of 9 kg capacity each, conforming to the quality requirements in accordance with the accepted standards [9-4(5)], shall be installed at points of access to the storage installations. The fire extinguishers shall be mounted keeping in view the ease of accessibility in accordance with good practice [9-4(8)] and Part 4 'Fire and Life Safety' of the Code.

11.4.7 For detailed information regarding LPG bulk storage installations reference may be made to good practice [9-4(9)].

12 USE OF PIPED NATURAL GAS (PNG)

12.1 The PNG infrastructure shall be in complete compliance with all the requirements of *Petroleum and Natural Gas Regulatory Board (Technical Standards*

and Specifications including Safety Standards for City or Local Natural Gas Distribution Network) Regulations, 2008.

12.1.1 The user-group/housing society concerned (referred hereinafter in these clauses as 'society') should contact the local city gas distribution (CGD) entity at the stage of the design of the building. This ensures that all the adequate provisions are incorporated in the design itself, as also the compliance with all the safety standards stipulated/required by the regulations/gas entities, as applicable from time-to-time. This ensures avoidance/mitigation of any rework at a later stage, or even situations where incorporation of any changes may become impractical or not possible, thereby rendering the building devoid of PNG infrastructure.

12.1.2 The entire gas pipeline infrastructure proposed to be laid in the premises of the society shall be easily accessible in future by the representatives of the CGD entity. Provision should be made by the builder for the same. Builder/society should ensure communication of the same to the future customer and should incorporate it in their agreements with the customer.

12.1.3 No permanent/temporary structure shall be erected on the ground along the paths where gas pipeline exists underground.

12.2 The PNG infrastructure inside the premises of societies primarily comprises the following:

- a) Underground medium pressure (MP) pipeline networks, comprising mainly polyethylene pipes and fittings;
- b) Underground low pressure (LP) pipeline networks, comprising mainly polyethylene (PE) pipes and fittings;
- c) Service regulator modules;
- d) Above ground riser and lateral system, comprising mainly ERW GI pipes and fittings; and
- e) Pipeline inside premise and/or kitchen of individual customer, comprising various components like meter regulator, diaphragm gas meter, copper pipe, brass fittings, brass valves, etc.

The guidelines mentioned under 12.3 to 12.6 give the minimum requirements to be complied with.

12.3 Guidelines for MP and LP Pipeline Networks

12.3.1 Gas pipelines are required to be laid at a minimum top cover of 1 m from the finished surface level. Underground PE pipeline shall not be laid through the basement.

12.3.2 A minimum clearance of at least 300 mm is

required to be maintained between the gas pipelines and any other obstacles/services.

12.3.3 Gas pipelines should not be laid closer to properties than as stipulated below:

<i>Pressure</i>	<i>Minimum Proximity</i>
Up to 0.01 N/mm ²	0.25 m
Up to 0.4 N/mm ²	3.00 m

12.3.4 If required, provision of underground ducts may be provided by the society within their premises at the time of construction of the building, to facilitate inserting of gas pipelines at a later stage. The duct through which gas pipeline is to be laid should not be shared with pipeline of any other utility, for safety reasons.

12.3.5 The ducts/sleeves should be 150 mm of PVC. The top cover of the sleeve should be at least 1 m below finish ground level. The material of ducts, sleeves and fittings to be used for construction shall be of high quality and in compliance with the concerned Indian Standards. In some cases, if applicable, there may be multiple number of ducts required to be laid.

12.3.6 Service chambers should be provided at 15 m to 20 m centre-to-centre (in case of straight sections) and also at bends, tees, and before and after slopes. Size of the service chamber shall be 1.0 m × 0.6 m (inside dimensions) and top of the cover of the duct should be at least 1.0 m high. Cover of the chamber should be capable of sustaining expected vehicular load. The service chamber should be filled with sand after MGL PE gas pipe is laid through the ducts provided.

12.3.7 The ducts for gas pipeline should be maintained at offset distance of at least 1.0 m from electrical services and 1.5 m from any other structure. Crossing with other utilities/services should be at a difference in level of at least 300 mm.

12.3.8 During the period between laying of ducts and insertion of gas pipeline, all the ends/entries of the ducts laid shall be temporarily closed to avoid the entry of mud, debris, rodents, etc, inside the ducts.

12.3.9 After the insertion of gas pipeline through ducts, the annular space between the duct and the gas pipe at all the ends (which creates possibility of entering undesired objects) should be plugged using a RCC half round pieces and plastered with cement.

12.3.10 The ducts and other elements of the duct system should be properly maintained subsequent to their installation and till the time of insertion of gas pipeline through the same.

12.4 Guidelines for Service Regulator Modules

The user-group/society should provide adequate open spaces in the premises for installation of gas equipment like regulating stations, which will be required to facilitate supply of PNG to the residents of the building/premise. The identified location shall be such that it does not obstruct any vehicular movement and is at a safe location in the premise.

12.5 Guidelines for Above Ground Riser and Lateral System

12.5.1 The riser and lateral system supplying gas to multi-storeyed residential buildings shall be in compliance with the requirements of the PNGRB regulations.

12.5.2 Multi-occupancy buildings having eight floors or more should have purpose-built utility shafts/ducts for accommodating riser and lateral system, which should be preferred route for constructing/locating the riser.

12.5.3 Provision shall be made for safe access to the riser and lateral system by the representatives of the CGD entity for future maintenance and repair. In the case of a continuous shaft, a concrete slab or similar flooring shall be provided for maintenance work at each floor.

12.5.4 Ventilation

12.5.4.1 Adequate provision for natural ventilation shall be provided in the building where PNG infrastructure is laid, so as to prevent any potential gas leaks from accumulating in the atmosphere to an unsafe level. Mechanical ventilation shall not be used to achieve the required ventilation levels. The minimum levels of ventilation in risers ducts/shafts shall be as given below:

<i>Cross Sectional Area (CSA) of Riser Duct</i>	<i>Minimum Free Area of Each High and Low Level Ventilation (Open Ventilator)</i>	<i>Typical Air Duct Size</i>	<i>Typical Ventilator Size</i>
m ²	m ²	mm	mm
Less than 0.01	0.002	Ø50	Ø70
0.01 to 0.375	0.010	Ø100	100 × 100
0.375 to 0.5	0.02	Ø150	100 × 200
0.5 to 7.5	0.05	Ø250	200 × 250
More than 7.5	1 percent CSA of the duct	–	–

12.5.4.2 Where the duct has a single ventilator that is part of the architectural design of the building, the free area of the ventilator to outside area shall be a minimum of 0.04 m² or 4 percent of the CSA of the duct, whichever is greatest.

12.5.4.3 Pipe work shall be installed in an unventilated void.

12.5.4.4 The pipe may enter the building to gain access to the riser shaft *via* a basement or car parking area, provided the area is well ventilated.

12.5.4.5 Any duct containing a riser or lateral shall be ventilated either directly to outside air, or indirectly to outside air *via* an area that is normally occupied and is itself ventilated to outside.

12.5.4.6 The provision of ventilation should be *via* permanent ventilators within the area/duct containing pipe-work.

12.5.4.7 All flammable release sources shall be at a lower elevation than the bottom of the highest ventilation opening.

12.5.4.8 Pipes may run in the same duct (subject to availability of adequate clearance from other utilities and ventilation) as most other services, including hot and cold water services, heating pipes, electrical conduits and cables and pipes containing other fuels. However, the following services shall not be installed in the same duct as gas pipes:

- a) Ventilation ducts and vacuum pipes that operate at sub-atmospheric pressure and that are not of all-welded or all-brazed construction; and
- b) Services containing oxidizing or corrosive fluids.

12.5.5 There shall be provision for installing risers and laterals such that a minimum distance of 300 mm is ensured from any electrical equipment or installations and associated excess current control boxes of fuse boxes, and 25 mm is ensured from the electricity supply and distribution cables and other metal piped services.

12.5.6 In case where the gas pipeline is required to cross through a wall, provisions (like core cutting) or holes of adequate size drilled through the wall/building structure, to accommodate an easy passage of the gas pipelines through them, shall be made. The elevation of these provisions/holes shall be near the roof and not near the floor of the room.

12.6 Guidelines for Pipeline Inside Premise and/or Kitchen of Individual Customer

12.6.1 Meters will normally be located inside the property on an outside wall with a minimum length of inlet pipe-work inside the property. Kitchen is the preferred room to locate the meter, thereby minimizing the length of the outlet pipe work.

12.6.2 The gas meter shall be installed in an area with adequate ventilation and at a proper location to facilitate safe and convenient meter reading and maintenance

activities in future. A minimum ventilation area of 2 percent of the internal floor area of the room shall be provided in the room where the gas meter is located. The gas pipeline inside the kitchen shall be laid along the walls of the kitchen and in a ventilated area.

12.6.3 In case pipe work is required to be laid in solid floors inside the kitchen, adequate provisions (in the shortest possible route and a minimum of 75 mm screed to provide an approximate cover of at least 50 mm over the gas pipe) shall be provided to protect the pipeline against corrosion and failure caused by movement. This method of construction consists of a base concrete raft foundation onto which a cement screed is subsequently laid in order to obtain a satisfactory surface to accept the floor finish. Provision of preformed ducts with protective covers should be made to facilitate laying of gas pipeline. It is advisable to contact the CGD entity at the designing stage so that adequate provisions are incorporated in the design of the kitchen/floor plan to facilitate easy and safe installation of PNG system.

12.6.4 Installation pipe work shall not be placed within the cavity of a cavity wall. Every pipe passing through a cavity wall shall take the shortest possible practicable route and shall be sleeved.

12.6.5 In case of provision of sleeve, the same should be of a diameter that provides a sliding fit to the pipe allowing normal pipe expansion/contraction.

13 USE OF MEDICAL GAS PIPELINE SYSTEM (MGPS)

13.1 General

A medical gas pipeline system (MGPS) is installed to provide a safe, convenient and cost effective system for the provision of medical gases to the clinical and nursing staff at the point of use. It reduces the problems associated with the use of gas cylinders such as safety, portorage, storage and noise.

MGPS generally handles distribution of oxygen, nitrous oxide, medical air, surgical air, medical vacuum only; and sometimes provides anaesthetic gas scavenging systems. All other gases used in hospitals have low volume use and are provided through cylinders at the point of use.

It is essential to ensure that there is no possibility of a cross-connection between any system and that all parts of each system to which connections can be made by users are gas specific.

Separate installations are provided for pathology, general laboratories and special laboratories. These are designated Laboratory Gases (Pipeline) Supply System (LGSS). LGSS is provided with valve controlled outlets and shall never be provided with medical gas terminal units.

Use and storage of medical gases is governed by *Indian Drugs and Cosmetics Act, 1940*.

13.2 Design and Installation

13.2.1 Pipelines Systems for Compressed Medical Gases and Vacuum

The design, installation, performance, documentation, testing and commissioning of pipeline systems for compressed medical gases, gases for driving surgical tools and vacuum in healthcare facilities to ensure continuous delivery of the correct gas and the provision of vacuum from the pipeline system, shall be in accordance with the good practice [9-4(10)]. This is inclusive of the requirements for supply systems, pipeline distribution systems, control systems, monitoring and

alarm systems and non-interchangeability between components of different gas systems.

13.2.2 Anaesthetic Gas Scavenging Disposal Systems

The design, installation, performance, documentation, testing and commissioning of anaesthetic gas scavenging disposal systems to ensure patient safety and to minimize exposure of the operator and other persons to anaesthetic gases and vapours, shall be in accordance with the good practice [9-4(11)]. This is inclusive of requirements for the power device, pipeline system, performance, non-interchangeability between key components and avoidance of cross connections between anaesthetic gas scavenging (AGS) disposal systems and medical gas and vacuum pipeline systems.

LIST OF STANDARDS

The following list records those standards which are acceptable as ‘good practice’ and ‘accepted standards’ in the fulfillment of the requirements of the Code. The latest version of a standard shall be adopted at the time of enforcement of the Code. The standards listed may be used by the Authority for conformance with the requirements of the referred clauses in the Code.

In the following list, the number appearing in the first column within parantheses indicates the number of the reference in this Section.

	<i>IS No.</i>	<i>Title</i>	<i>IS No.</i>	<i>Title</i>	
	(5)	14885 : 2001	15683 : 2006	Specification for portable fire extinguishers — Performance and construction	
	(2)	IS/ISO 7396-1 : 2007	9798 : 2013	Low pressure regulators for use with liquefied petroleum gas (LPG) mixtures	
		IS/ISO 7396-2 : 2007	4786 : 2014	Specification for variable high pressure regulators for use with liquefied petroleum gas	
(3)	3196 (Part 1) : 2013	Medical gas pipelines systems : Pipelines systems for compressed medical gases and vacuum	(7)	6044 (Part 1) : 2013	Liquefied petroleum gas storage installations — Code of practice: Part 1 Residential, commercial and industrial cylinder installations (<i>second revision</i>)
		Anaesthetic gas scavenging disposal systems	(8)	2190 : 2010	Code of practice for selection, installation and maintenance of first-aid fire extinguishers (<i>fourth revision</i>)
		Specification for welded low carbon steel cylinders exceeding 5 litres water capacity for low pressure liquefiable gases: Part 1 Cylinders for liquefied petroleum gases (LPG) (<i>sixth revision</i>)	(9)	6044 (Part 2) : 2001	Code of practice for liquefied petroleum gas storage installations : Part 2 Commercial, industrial and domestic bulk storage installations (<i>first revision</i>)
		7142 : 1995	(10)	IS/ISO 7396-1 : 2007	Medical gas pipelines systems : Pipelines systems for compressed medical gases and vacuum
(4)	8198 (Part 5) : 1984	Code of practice for steel cylinders for compressed gases: Part 5 Liquefied petroleum gas (LPG) (<i>first revision</i>)	(11)	IS/ISO 7396-1 : 2007	Anaesthetic gas scavenging disposal systems

NATIONAL BUILDING CODE OF INDIA

PART 10 LANDSCAPE DEVELOPMENT, SIGNS AND OUTDOOR DISPLAY STRUCTURES

Section 1 Landscape Planning, Design and Development

BUREAU OF INDIAN STANDARDS

CONTENTS

FOREWORD	...	3
1 SCOPE	...	5
2 TERMINOLOGY	...	5
3 STATUTORY APPROVALS	...	7
4 LANDSCAPE SITE PLANNING REQUIREMENTS	...	10
5 GENERAL LANDSCAPE DEVELOPMENT GUIDELINES	...	10
6 SIGNAGE	...	16
7 PLANTING DESIGN	...	16
8 SPECIFICATIONS FOR PLANTING WORKS	...	23
9 SERVICE/UTILITIES IN LANDSCAPE DEVELOPMENT	...	27
10 ROOF LANDSCAPE	...	29
11 PROTECTION OF LANDSCAPE DURING CONSTRUCTION	...	29
12 SOIL AND WATER CONSERVATION	...	32
13 STREET FURNITURE	...	34

FOREWORD

This Code (Part 10/Section 1) covers provisions relating to landscape planning, design and development with the aim of improving quality of outdoor built environment and protection of the land and its resources.

This Part of the Code was first published in 1970 and subsequently revised in 1983 and 2005. This Part earlier covered provisions relating to only signs and outdoor display structures. With growing urban development and environmental degradation, it had become imperative to determine landscape design parameters, and also provide rules, regulations, controls and procedures for the protection, preservation and modification of surrounding environment. In the last revision of 2005, this Part was, therefore, sub-divided into two sections as follows, by including a new section relating to landscaping:

- Section 1 Landscape planning and design
- Section 2 Signs and outdoor display structures

The components of landscape design and external development were earlier covered in the Code in its various Parts/Sections but a comprehensive treatment was given in this new Section in the last revision only. A brief clause on street furniture was also introduced in this Section in the last revision.

In this revision, the Section is now called, Section 1 Landscape planning, design and development, and accordingly various provisions have been detailed to cover relevant aspects relating to overall landscape planning, design and development. In this revision, the following modifications have been incorporated:

- a) Certain terminologies have been included/modified in view of the inclusion of above mentioned provisions and technological advancements in this field.
- b) A new clause relating to landscape site planning requirements has been included.
- c) A new clause covering in detailed guidelines relating to general development of landscapes has been included.
- d) A new clause relating to roof landscape has been added.
- e) Provisions relating to earth slopes and their grading have been shifted and now covered under the clause on statutory approvals.
- f) New provisions related to materials and finishes plan have been included as part of the landscape development documents required for statutory approvals.
- g) Provisions relating to paved surfaces in external areas have been shifted and now included under general development of landscapes for logical sequencing.
- h) Lists of various plant species for different applications have been updated under various clauses.

The work of landscape planning, design and development is to be carried out by professionals in accordance with their qualification and competence given in Part 2 'Administration' of the Code keeping in view the provisions of this Section.

For the purpose of deciding whether a particular requirement of this Section is complied with, the final value, observed or calculated, expressing the result of a test or analysis, shall be rounded off in accordance with IS 2 : 1960 'Rules for rounding off numerical values (*revised*)'. The number of significant places retained in the rounded off value should be the same as that of the specified value in this Section.

NATIONAL BUILDING CODE OF INDIA

PART 10 LANDSCAPE DEVELOPMENT, SIGNS AND OUTDOOR DISPLAY STRUCTURES

Section 1 Landscape Planning, Design and Development

1 SCOPE

This Code (Part 10/Section 1) covers requirements of landscape planning, design and development with the view to promoting quality of outdoor built and natural environments and the protection of land and its resources.

2 TERMINOLOGY

For the purpose of this Section, the following definitions shall apply.

2.1 Avenue — A wide road or pathway lined with trees on either side.

2.2 Buffer — The use of landscape elements to reduce or curtail view, sound or dust with plants or earth berms, wall etc.

2.3 Canopy/Tree canopy — The average horizontal spread of the tree, taken from dripline to dripline.

2.4 Climber — A woody or herbaceous plant which either clings to a wall, trellis or other structures or can be supported or trained as it grows.

NOTE — It is sometimes also called creeper or vine.

2.5 Columnar — A slender, upright plant form.

2.6 Contour — The form of the land, existing or proposed; a part of the topography, indicated by map lines at intervals, to understand the landform clearly. The contour line is imaginary and indicates continuous elevation above mean sea level or an assumed datum line.

2.7 Contour Interval — The difference in elevation or the vertical distance measured between consecutive contour lines.

2.8 Drainage — Drainage is the natural or artificial removal of surface and subsurface water from an area through use of vegetated/open channel, pipes, drain boards, chambers, etc.

2.9 Egress — A way out, or exit.

2.10 Elevation — A contour line or notation of relative altitude with respect to a benchmark, useful in plotting existing or proposed feature.

2.11 Erosion — Wearing away of soils, rocks, sediments, etc, by gradual action of natural processes (such as water, wind and glacier).

2.12 Exotic — A plant that is not native to the area in which it is planted.

2.13 Fence — A barrier of plant or construction material used to define the boundary of an area and to restrict visual and/or physical access.

2.14 Foliage — The collective leaves of a plant or plants.

2.15 Geogrid — A deformed or non-deformed netlike polymeric material used with foundation, soil, rock, earth, or any other geotechnical engineering-related material as an integral part of the human made project structure or system.

2.16 Geo-Textile — Any permeable textile or fabric (natural or synthetic) used to retain or protect soil and filter and drain water as an integral part of project, structure or system such as terrace garden, etc.

2.17 Girth of Tree — Girth is a measurement of the circumference of the trunk of a tree, measured perpendicular to the axis of the trunk. It is measured at breast height (1.4 m above ground level).

2.18 Grade — The slope or lay of the land as indicated by a related series of elevations.

2.18.1 Natural Grade — Grade consisting of contours of unmodified natural landform.

2.18.2 Finished Grade — Grade accomplished after landscape features are installed and completed as shown on plan as proposed contours or spot levels.

2.19 Gradient — The degree of slope of a pipe invert or road or land surface. The gradient is a measure of the slope height as related to the length. The slope is expressed in terms of percentage or ratio.

2.20 Grading — The cutting and/or filling of earth to establish finished contours.

NOTE — Grading facilitates good drainage and shapes land to suit the intent.

2.21 Grasses — Plants that characteristically have joint stems, sheaths and narrow blades (leaves).

2.22 Grass Paver — Grass paver is a permeable structural grid cellular system (concrete, HDPE or any other polymer) for containing and stabilizing gravel or turf.

2.23 Green Roof — A roof surface of a building that is partially or completely covered with a growing medium and vegetation. Green roofs can be deep (intensive) or shallow (extensive).

NOTE — Intensive green roofs are elevated greens which can sustain shrubs, trees, walkways and benches with their complex structural support, irrigation, drainage and root protection layers. Extensive green roofs are shallow, relatively light and are solely used for their environmental benefits. They support native ground cover that requires little maintenance.

2.24 Green Walls — A supporting structure completely or partially covered with vegetation which is grown with soil or growing medium. It can be either free standing or part of a structure. They include climbing plants such as vines that grow directly on the wall, or walls that comprise of modular panels, containers and an integrated irrigation system.

2.25 Ground Cover — The planting material that forms a carpet of low height.

2.26 Hard Landscape — Civil work component of landscape development such as pavements, walkways, roads, retaining walls, sculptures, street amenities, fountains and other elements of the built environment.

2.27 Hardy Plant — Plants that can withstand harsh temperature variations, harsh wind, pollution, dust, extreme soil conditions, and can tolerate either drought or flooding.

2.28 Heat Island Effect — A phenomenon in which air and surface temperature of an area are higher than nearby areas due to the replacement of natural land cover with pavement, building, and other infrastructure.

2.29 Hedge — Shrubs or trees (usually of the same species) planted closely together in a linear configuration. A hedge may be pruned to shape or allowed to grow to assume its natural shape.

2.30 Herb — A plant with a non-woody or fleshy structure. Certain herbs are highly useful for cooking or of high medicinal value.

2.31 Ingress — A way in, or entrance.

2.32 Invert — The lowest inside point of a pipe, culvert, or channel.

2.33 Irrigation — The artificial application of water, to assist in growing and maintenance of plants.

2.34 Kerb — A concrete or stone or similar hard edging along a pathway, or along a road, often constructed with a channel to guide the flow of stormwater.

2.35 Microclimate — A local atmospheric zone where the climate (temperature, humidity, wind, etc) differs from the surrounding areas. The term may refer to areas as small as a few square metres or as large as many square kilometres.

2.36 Mound — A small hill or bank of earth, developed as a characteristic feature in landscape.

2.37 Mulching — A practice of using a protective covering, usually of organic matter such as leaves, straw, placed around plants to retain moisture, improve soil conditions and prevent the growth of weeds.

2.38 Permeable Paving — Paving surfaces that reduce runoff by allowing rainwater to soak through the surface into the underlying sub-base where the water is stored temporarily before allowing it to seep into the ground or flow to the drains.

2.39 Plants — The living beings consisting of trees, shrubs, herbs, grasses, ferns, mosses, etc, typically growing in a permanent site, absorbing water and inorganic substances through their roots, and synthesizing nutrients in their leaves through the process of photosynthesis.

2.39.1 Endemic Plant — The plant which is found only in one geographic location on earth.

2.39.2 Invasive Plant — The species of plant which is not native to a specific location (an introduced species) and has a tendency to spread to a degree believed to cause damage to the environment.

2.39.3 Native Plant — A plant indigenous to a particular locale.

2.39.4 Naturalised Plant — A plant that is established as a part of the flora of a locale other than its place of origin.

2.40 Screen — A vegetative or constructed hedge or fence used to block wind, undesirable views, noise, glare and the like, as part of in landscape design; also known as ‘screen planting’ and ‘buffer plantation’ (*see also 2.2*).

2.41 Sediment — The product of erosion processes; the solid material, both mineral and organic, that is in suspension, is being transported or has been moved from its site of origin by air, water, gravity or ice.

2.42 Shelterbelt — Shelterbelt is usually made up of one or more rows of trees or shrubs planted in such a manner so as to provide shelter from wind, and protect soil.

2.43 Shrub — A woody plant of low to medium height, deciduous or evergreen, generally having many stems.

2.44 Soft Landscape — The natural elements in landscape design, such as plant materials and the soil itself.

2.45 Spot Elevation — In surveying and contour layout, an existing or proposed elevation of a specific point noted as a dot on the plan.

2.46 Street/Outdoor Furniture — Items of furnishing in outdoor landscape such as benches, trash receptacle signage, play equipment.

2.47 Swale — A linear wide and shallow depression used to temporarily store, route or filter runoff. A swale may be grassed or lined.

2.48 Topsoil — The uppermost layer of the soil.

2.49 Transplanting — Technique of moving a plant from the place where it is growing and replanting at another location.

2.50 Tree — A woody plant, generally taller than 2.00 m, with a well-distinguished trunk or trunks below the leaf crown.

2.50.1 Deciduous Tree — Tree that sheds all its leaves during a part of the year.

2.50.2 Evergreen Tree — Tree that remains green for most part of the year and sheds leave slowly throughout the year.

2.51 Tree Drip Line — The branch spread of a tree defined by the outermost circumference of a tree canopy where water drips onto the ground.

2.52 Tree Grate — A grille, installed at the base of a tree otherwise surrounded by pavement that allows the free passage of air, water, and nutrients to the tree root, but does not interfere with the foot traffic.

2.53 Tree/Plant Guard — The protection around a tree or plant to help prevent damage.

2.54 Xeriscape — A landscape that requires little or no irrigation or other maintenance.

3 STATUTORY APPROVALS

3.1 Requirements for Registration and Competence of Professionals

The qualification and competence for carrying out the landscape planning, design and development work shall be as given in Part 2 ‘Administration’ of the Code.

3.2 Application for Statutory Approvals and Required Drawings

For any development project for which a permit or licence or statutory approval is required, an application shall be made to the Authority on the prescribed form containing such particulars as the Authority may require. The form shall be signed by the owner and shall include the information given in 3.3. For various aspects of obtaining the permit, etc, reference shall be made to Part 2 ‘Administration’ of the Code.

3.3 Landscape Development Documents Required for Statutory Approvals

3.3.1 Landscape Master Plan

The site plan to be submitted with the application for permit shall be drawn to a scale of not less than 1 in 200

for a site up to one hectare and not less than 1 in 500 for site up to 10 hectare and not less than 1 in 1 000 for site more than 10 hectare. The following information shall be provided in addition to requirements for site plan as stated in Part 2 ‘Administration’ of the Code:

- a) Existing and proposed topographic contours at intervals not exceeding 500 mm and/or spot elevations as pertinent and bench mark of site with reference to the city datum relative to the mean sea level.
- b) Limits of the 100 year flood plain and water surface elevation, where applicable.
- c) Location of existing major physical features, such as railway track, drainage ways.
- d) Location of service utilities adjacent to the project with relevant top and invert levels clearly indicated.
- e) Point of egress and ingress including locations and width of road.
- f) Fully dimensioned loading spaces and manoeuvring areas.
- g) Parking including, location, parking spaces, size and number, and typical parking space details for both persons with disabilities and for standard spaces.
- h) Circulation for vehicles, bicycle and pedestrian, including for persons with disabilities clearly identified.
- j) Detail for parking areas including type of lighting, material for paving, and security rooms, rest rooms; and type of directional signage, etc.
- k) Drainage system, proposed finished ground elevations and finished grades.
- m) Location of proposed fire hydrant points.
- n) Location of fire lanes.
- p) Proposed lighting layout.
- q) Landscape irrigation points and source of irrigation water.
- r) Vegetation for screening by type, material, height, location, and spacing or fences, walls.
- s) Location of proposed street furniture, landscape structure.
- t) Refuse container location, size, and access.
- u) Landscape paving materials with location.
- w) Location, type, size, and height of existing and proposed signage.
- y) List of existing trees with botanical and common names and height, girth, canopy of the tree and existing grade levels (*see 11.1.2 for plant material schedule*).
- z) Prior approvals, where applicable.

3.3.2 Grading Plan and Stormwater Management Plan

The grading plan shall be drawn to a scale of not less than 1 in 200 for a site up to one hectare and not less than 1 in 500 for a site up to 10 hectare and not less than 1 in 1 000 for site more than 10 hectare. The grading plan should include measures for soil and sedimentation control and also measures during construction to prevent soil erosion, and also water harvesting practices (*see also 11 and 12*).

3.3.2.1 Grading design

Design for changes in elevation in the outdoor environment is a primary component of landscape development. Grading of proposed external development areas should relate to the existing topography of the site and it should direct surface water runoff to the designated drainage and water harvesting area. Grading design parameters are as follows:

- Proposed grading design should respond to the function and purpose of the activities to be accommodated within the site.
- New development and structures to be integrated with existing landform within the site and in its immediate surroundings.
- Stormwater to be directed away from buildings.
- Steep slopes to be modified to minimize or eliminate erosion.
- Legally, grades cannot be changed beyond the property line of the site.
- Rate of stormwater runoff leaving the site after construction not to exceed the pre-construction rate.
- Grading design should optimize cut and fill.

3.3.2.2 Grading plan

3.3.2.2.1 The submitted grading plan should include the following:

- All existing and proposed features of the site, including all building with plinth level;
- Structures such as walls, walks, steps, roads;
- Utilities such as water lines, sewer and stormwater drainage, electrical lines; and
- Utility structures like manholes, junction boxes, sewage treatment plant, septic tank, soak pit, water tanks, water treatment plant, transformers and all underground structures indicated appropriately.

Proposed features shall be indicated in firm lines and existing features in dash.

3.3.2.2.2 The grading plan should represent the following:

- General landform concept graphically represented with appropriate symbols and abbreviations (*see 3.3.2.4*).
- Proposed contour lines should be integrated with existing and proposed elevations within the project site.
- Location of swales and surface water flow, surface and subsurface soil drainage system or water harvesting systems.
- Location of drainage catchments, areas of retention/detention or disposal/outfall point as the case may be.
- Spot grades on road, walks, and swales including top level and relevant invert levels of all utilities and utilities structures as mentioned above; critical spot elevation to be established (*see 3.3.2.3*).
- Spot elevation of building floor finish level, steps, walls, terraces and other such structures.
- Changes in direction or rate of slope.

3.3.2.2.3 Spot elevations

Spot elevations shall be used to supplement contours in the following situations:

- To indicate variations from the normal slope or gradient between contour lines.
- To indicate elevations of intersecting planes and lines, like corners of buildings, walls, steps and kerbs.
- To indicate elevations at top and bottom of vertical elements like walls, steps and kerbs.
- To indicate floor and entrance elevations.
- To indicate elevations of high and low points.
- To indicate top elevations of utilities and utilities structure.

3.3.2.3 Slope calculation

Slopes are expressed as follows:

$$\text{a) Percentage (of slope)} = \frac{\text{Vertical rise} \times 100}{\text{Horizontal distance}},$$

$$\text{for example, } \frac{1 \times 100}{50} = 2 \text{ percent}$$

$$\text{b) Proportion (of slope)} = \frac{\text{Vertical rise (1.0 m)}}{\text{Horizontal distance}},$$

$$\text{for example 1 m in 50 m or 1 : 50}$$

- Degree of slope, expressed as angle, for example, 10°, 15°, etc.

3.3.2.4 Typical grading symbols and abbreviations

Symbol	Description
--(100)--	Existing contour
- 100 -	Proposed contour
(100.5)	Existing spot elevation
100.5 (Bold)	Proposed spot elevation
CB	Catch basin
FFL	Finished floor level
FGL	Finished ground level
TW/BW	Top of wall/Bottom of wall
TK/BK	Top of kerb/Bottom of kerb
HP/LP	High point/Low point
IL	Invert level

3.3.3 Planting Plan

The planting plan shall be drawn to a scale of not less than 1 in 200 for a site up to one hectare and not less than 1 in 500 for a site up to 10 hectare and not less than 1 in 1 000 for site more than 10 hectare with part plans at 1 in 200 of two of the design areas. Planting plan should include plant material schedule as shown in Table 1. The planting plan and landscape plan shall show identical information to avoid conflict between both plans. The planting plan shall include the layouts as per the following requirements, drawn to the scale:

- Location of proposed trees, shrubs, ground covers including grass area indicated clearly with appropriate symbols and legend shall be indicated.
- The shape, size, diameter of canopy of plants with their possible growth in coming 3 years shall be indicated.
- Functional attributes and growth pattern tabulation shall be attached as given in Table 2, as an annex.
- All existing vegetation shall be marked on the landscape plan and areas designated for preservation of existing vegetation on site shall be demarcated clearly (*see also 11.1.2*).
- A concept plan of scale not less than 1 in 1 000 indicating the intent of the design with respect to the functions for various parts of the scheme shall be included with a short narrative, where applicable.

Table 1 Plant Material Schedule

(Clause 3.3.3)

Sl No.	Tree No.	Code	Botanical Name	Common Name	Quantity
(1)	(2)	(3)	(4)	(5)	(6)

Table 2 Plant Material Schedule Showing Functional Attributes and Growth Pattern of Each Plant

[Clause 3.3.3 (c)]

Sl No.	Relevant Features	Description Plant-1
(1)	(2)	(3)
i)	Botanical name	
ii)	Common name	
iii)	Plant code	
iv)	Type (Evergreen/Deciduous)	
v)	Height	
vi)	Spread/Canopy	
vii)	Form of tree	
viii)	Flower colour	
ix)	Seasonal duration	
x)	Zone (Functional attributes)	
xi)	Characteristics	
xii)	Function	
xiii)	Remarks (including with regard to poisonous character and health ground)	

3.3.4 Materials and Finishes Plan

The materials and finishing plan shall be drawn to a scale of not less than 1 in 500 for a site up to 10 hectare and not less than 1 in 1 000 for site more than 10 hectare. The plan shall include materials specifications such as type, colour, size, thickness, and surface treatment.

3.3.5 Basic Design and Construction Details

Construction details, specifications and methods used for the following landscape elements are to be included, where applicable:

- All paved areas for pedestrian and vehicular use, including edges, kerbs, bumper stops, steps, ramps, planters, railings or other protective devices; tree protection with tree grating, tree guard, etc; provision for wheel chair access and movement, and other accessibility details in accordance with 13 of Part 3 ‘Development Control Rules and General Building Requirements’ of the Code.
- Boundary wall, fence, retaining wall, etc.
- Structures in landscape such as gatehouses, kiosks, toilets, pergolas, space frame, pools, ponds, water bodies, any other special features.
- Site utilities such as stormwater drains, manholes, catch basins, outdoor lighting fixtures, electric feeder pillars, junction box, fire hydrant, garbage collection points, litter bins.
- Outdoor signage and street furniture.
- Play equipment and tot lots, where appropriate.

- g) Any other relevant detail or information.

3.3.6 Irrigation Plan

The irrigation plan shall be drawn to a scale of not less than 1 in 500 for a site up to one hectare and not less than 1 in 1 000 for site more than one hectare. The plan shall include the following information:

- a) Source of irrigation water.
- b) Type of water conserving irrigation systems proposed, if any.
- c) Extent of supplementary irrigation provided by water harvesting measures, if any.
- d) Layout of the irrigation system proposed (including arrangement of hydrants or sprinklers indicating location and type with typical details and specifications, etc as applicable to the irrigation system).

4 LANDSCAPE SITE PLANNING REQUIREMENTS

4.1 Framing the Landscape Programme or Brief

Every site has a history of use and change. Prior to formulation of a landscape master plan and its detailed design, an assessment of the landscape requirements for the site shall be established.

4.1.1 Location

Landscape development brief shall include appropriate approaches for regional and bio-climatic variations.

4.1.2 Site

Specific site factors such as topography, site aspect, hydrology, soils, existing vegetation, visual value, drainage, utilities, subsurface conditions, vegetation, microclimate, existing site infrastructure, built mass, traffic and connectivity shall be considered while developing the brief for landscape development.

4.1.3 Brief

Landscape development brief shall be in consonance with the statutory/development requirements.

4.1.4 Users

Landscape development brief should be framed for specific uses or user groups including understanding of social, economic and safety related aspects.

4.1.5 Landscape Development for Special Conditions

The landscape development brief shall recognize special conditions, such as reclamation and/or rehabilitation of land, mitigation of other special existing conditions and conservation of existing value, prior to formulating a landscape master plan.

5 GENERAL LANDSCAPE DEVELOPMENT GUIDELINES

5.1 General

5.1.1 The general landscape development guidelines should be applied at two levels:

- a) *Masterplan level* — This consists of those projects where the level of intervention is restricted to large scale landscape site planning; and
- b) *Detailed landscape design level* — This consists of those projects where detailed landscape design is involved.

Open spaces are often further defined based upon access and ownership as public, semi-public and private. Planning and design of open spaces should consider the following aspects:

- 1) *Sustainability* — Environmental sustainability and green principles may be incorporated to ensure that landscape development does not hamper the existing ecology of the site and its surroundings (*see also* Part 11 ‘Approach to Sustainability’ of the Code). Land, vegetation and water sensitive design options may be explored during the design stage by incorporating a clear grading, drainage and planting strategy while developing the landscape concept. Cut and fill of the land may be minimized while locating the built blocks and circulation spaces. Gentler slopes with adequate green cover aids in erosion control thereby retaining the humus rich top soil. Stormwater runoff within the site may be filtered and either stored or allowed to recharge the groundwater table depending on the site conditions. As far as possible, it is desirable to use native and naturalized non-invasive species.
- 2) *Accessibility* — The planning and design of open spaces may be accessible for a wide range of users, including pedestrians, cyclist, transit riders and those using private modes of transport (*see also* 13 of Part 3 ‘Development Control Rules and General Building Requirements’ of the Code). An ideal public space may be well connected to a surrounding bus/metro/mass rapid transit system facility or a neighbourhood street or a regional route.
- 3) *Resilience* — Resilience is the ability of a landscape to adapt to change and regain its original state when subject to shock, such as flooding, drought and pest attack. Natural

landscapes have an inherent ability to exhibit resilience, while human altered landscapes should be designed to incorporate resilience as a core principle of design.

- 4) *Ease of maintenance* — Ease of maintenance may be regarded as an important consideration in a well-designed landscape. This may also aid in ensuring savings in energy and resources.

5.1.2 The various guidelines for landscape spaces may be grouped as follows, which are given in **5.2** and **5.3**, respectively:

- a) *Guidelines for general open spaces* — These pertain to open spaces framed for specific uses and user groups, and include understanding of social, economic and safety related aspects.
- b) *Guidelines for special conditions* — These pertain to open spaces which are either ecologically or culturally significant, and may require special considerations, such as reclamation, rehabilitation, restoration and/or redevelopment.

5.2 Design Guidelines for General Types of Landscape Open Spaces

5.2.1 The design for the general type of open spaces should consider the following parameters:

- a) *Hierarchy of open spaces* — Open spaces may be studied with respect to its relative size to better understand the complexities of the issues related to them, with respect to functional, visual and ecological concerns.
- b) *Usage of open spaces* — Design of open spaces should have a certain character based on its usage. It is desirable that the design of these open spaces take into consideration the existing and proposed use of the open space, as well as the specific needs of the users. The design of these spaces may also be reviewed in terms of whether they are public, semi-public or exclusively private spaces. Open spaces may be planned for a variety of functional uses by different users or diverse user groups, so that they are able to provide for a variety of recreational opportunities and spatial experiences.
- c) *Location of spaces* — The design guidelines may be interpreted so as to suit the biogeoclimatic setting of these landscapes. The approach to planning and design of these open spaces would vary greatly depending on the climatic conditions and layout of the site. The specificities of the requirements for landscape

should be studied in detail before commencing the planning and design process.

The following types of generic open spaces may be identified:

- 1) Regional parks/city parks,
- 2) Roads,
- 3) Public plazas and urban squares,
- 4) Multipurpose open spaces/mela grounds,
- 5) Urban riverfronts and waterfronts,
- 6) District parks/neighbourhood parks,
- 7) Theme parks/waterparks,
- 8) Sports facilities/playgrounds/stadium complexes/sports centre,
- 9) Golf courses/equestrian grounds,
- 10) Plant nurseries,
- 11) Pocket parks, and
- 12) Open spaces associated with largescale developments.

5.2.2 Design to Take into Consideration the Site Context

- a) The site and context study are important tools for assessing the suitability of land use and nature of design intervention. The design for any particular site may be developed as an outcome of the site analysis.
- b) The design may be conceptualized so as to maximize the site potentials while the site constraints should also be taken into consideration.

5.2.3 Design for Maximising Usable Space

- a) Landscape elements, such as outdoor furniture, lighting and other required facilities, may be placed sensitively along the proposed circulation path with consideration of usage patterns.
- b) Adequate shading may be provided for areas where the community congregates in warmer climatic locations, while areas designed for public gathering in cold regions may be shielded from wind.
- c) The extent of the paved areas may be restricted to a minimum, keeping in mind the pedestrian routes, density of usage, spaces for congregation, etc. Paved areas may be planned so that they do not restrict any natural surface flow of water and nor do they get waterlogged during the rainy months.
- d) Landscape design may be used to improve the environmental quality of the open spaces. Sufficient landscape may be provided at both

horizontal and vertical planes to reduce the ambience temperature and glare. This may be in the form of conventional planting or devices like vertical greenwalls, green roofs, etc. Large unshaded paved plazas may contribute to urban heat island effect. *See 7.1.2.2 and 7.4.7* of Part 11 'Approach to Sustainability' of the Code.

5.2.4 Provision for Various User Activities Spanning Different Age Groups

- a) A variety of recreational options for different ages and interests may be provided.
- b) Different cultural recreation preferences may be considered while designing open spaces by using community feedback to determine their needs and requirements.
- c) A variety of amenities that encourage extended use, such as water fountains, and picnic tables, may be provided.
- d) Plants for hiding and materials for making shelters may be considered. Opportunities to create appreciation for nature and the pleasure of discovering scientific phenomenon may be provided.
- e) Spaces should be designed for use by people of all abilities, including those using mobility aids (for example, wheelchairs). *See 13* of Part 3 'Development Control Rules and General Building Requirements' of the Code.

5.2.5 Provision for Free and Imaginative Play Opportunities in Children's Play Areas

- a) Opportunities for children to explore imaginative play through interaction with natural elements of their environment may be provided.
- b) Raised beds or planting areas, play shelters, niches, sand areas, etc, may be provided.
- c) Ways of functioning of natural systems within the site may be explored. For example, hydrology and water flows that attract butterflies, birds, and frogs may be considered.
- d) Science play opportunities that stimulate curiosity about science may be provided. Suggested elements may include centrifugal force, sound waves, sunlight refractors, weather stations and windmills.
- e) Signage that gives cues to parents about things to show or teach their children, using equipment or other elements of the playground, may be provided.
- f) All possible efforts should be made to extend opportunities to children of all abilities and age, by providing access to a variety of play

features and using features that appeal to all of the senses. *See 13* of Part 3 'Development Control Rules and General Building Requirements' of the Code.

5.2.6 Design for Safety and Security

- a) Hard landscape materials and their details may be worked out so that sharp corners, injurious edges and easily breakable materials are avoided in the public landscape.
- b) Plant materials may be selected taking into consideration the possible issues of allergic reactions or toxicity.
- c) Level differences in the open spaces may be treated with adequate care so as to avoid potential fall/injury. Level differences of a single step may be avoided in landscaped areas since they may aggravate the chances of tripping and injury.
- d) Durable, easy to repair equipment and safety surfacing may be considered for play areas. International Safety Standards, such as fall zones, safety surface, fall height, and entrapment concerns may be considered for play equipment and surfaces. The flooring material of these spaces may be impact absorbing and injury proof.
- e) In areas for smaller children, the number of exits and their placement may be limited so that they are easily monitored by parents and guardians.
- f) Creation of hidden areas in the landscape should be avoided. The density of vegetation and height of the understory planting may be decided so as to keep the view-lines clear.
- g) Lighting may be done so as to ensure that all usable areas of the landscape are well lit and there are no dark spots in the landscape.

5.2.7 Review of Existing Master Plans, Regulations and Initiatives

Existing master plans, regulations, byelaws, etc, that may have defined uses, connections, materials or conventions, shall be reviewed for ensuring compliance. Design of public open spaces may address the concerns of the neighbourhood and express the identities of the neighbourhoods they pass through.

5.2.8 Design for Continuity Between Multiple Public Open Spaces and Parks

- a) Linear parks may be used to provide continuous paths for bicycles and pedestrians.
- b) Greenway plans may be researched and opportunities to connect greenway paths be explored so as to establish connections

between adjacent neighborhoods. Pedestrian movement corridors may be given precedence over vehicular corridors.

- c) Commuting or high speed bike lanes may be separated from the pedestrian paths.
- d) Signage style and vocabulary along multiple open spaces and parks to guide users may be kept consistent for ease of understanding. *See* Part 10 'Landscape Development, Signs and Outdoor Display Structures, Section 2 Signs and Outdoors Display Structures' of the Code.

5.2.9 Pathways and Pedestrian Movement Corridors

- a) Pedestrian circulation path consists of sidewalks, wheelchair ramp, and landings. Footpaths of minimum width 1.80 m may be provided along the length of road for any public or private building where pedestrian traffic is expected. *See* 4.3.2.1 of Part 3 'Development Control Rules and General Building Requirements' of the Code for computation of capacity of footpaths with respect to their widths.
- b) Natural materials such as stone, or manmade materials such as tiles or cast *in-situ* concrete, of appropriate thickness may be used as paving finish in external areas. Adequate slope and drainage facility may be considered for all external paved surface integrating it with the pavement design.
- c) Surface treatment of the finishes may be such that it remains anti-skid throughout the seasons. Smooth finish is not recommended for external areas except to convey any design concept.
- d) Change in levels and steps may be depicted in different texture or colour as a visual clue.
- e) The cross slope of sidewalk may be designed so as not to exceed two percent (1 in 50). The longitudinal slope of path may not exceed 1 in 20, unless the longitudinal slope of the road exceeds this maximum, in which case the norms applicable to a ramp should be applied. Kerb ramps may be provided at pedestrian crossings. *See also* 13 of Part 3 'Development Control Rules and General Building Requirements' of the Code.
- f) All ramps should have minimum width of 1.20 m, excluding edge protection. The cross slope of ramp should not exceed 1 in 50 and the longitudinal slope of ramp may not exceed 1 in 12. All ramps may have an unobstructed level landing both at top and bottom of the ramp. The landing may have the minimum width as that of the ramp. The landing may be

minimum 1.50 m in length. Any ramp beside the road may be located in such a way so that vehicles cannot park blocking the access. The ramps shall also comply with the requirements of 13 of Part 3 'Development Control Rules and General Building Requirements' of the Code.

- g) Handrails may be provided for any ramp with a vertical height greater than 150 mm, to prevent pedestrians and wheelchair users slipping from the ramp. The height of the top handrail may be 900 mm from the top surface of the ramp. The ramp surface may be rough finished. All ramp and landing may be designed so that water does not collect on the surface of the ramp or landing.
- h) Requirements of 7.4.3 of Part 11 'Approach to Sustainability' of the Code should also be taken in to consideration.

5.2.10 Provision for Adequate Parking Requirements

- a) Parking spaces may be provided off-street or as dedicated parking pockets with ample turning radii for manoeuvrability of vehicles.
- b) The parking lots need to be shaded during the day while being well lit during the night and should be easily accessible.
- c) Pedestrian connections to and fro the parking lots may be denoted with easily recognizable signage elements.
- d) The parking spaces shall be provided in accordance with 10 of Part 3 'Development Control Rules and General Building Requirements' of the Code.
- e) Parking bays for persons with disabilities shall be provided as per 13 of Part 3 'Development Control Rules and General Building Requirements' of the Code.

5.2.11 Adopting Rational Approach to Grading

- a) Grading may be used to minimize creation of steep slopes and retaining walls in the landscaped areas by assessing the existing contours and locating the functional landscape spaces, taking into consideration the existing layout of the land.
- b) Site grading may generally be limited to areas adjacent to the building, under access roads and driveways, or in areas where cut and fill are inevitable such as those sites which are prone to landslides.
- c) Buildings and roads may be planned so as to generally follow the existing contours. On sloping sites, buildings may have multiple levels to maximize the potential of contoured sites.

- d) Wherever possible, measures like naturally stabilizing slopes and bio-engineering measures may be explored in order to avoid construction of retaining walls.
- e) Where grading occurs, new slopes may be configured to retain the natural character of the site. New contour lines may be carved to mimic the natural contours.

5.2.12 Designing for Road Landscapes

- a) Kerbs may be provided on the edges of the driveways to adequately control drainage within the road, prevent moisture from entering the sub-grade, separate the road from the pedestrian area, and provide adequate lateral support for the pavement structure.
- b) The roads should provide clear access to fire fighting vehicles, ambulance, sanitation vehicles, etc, and also allow for safe movement for vehicles, pedestrians and wheelchair users. The road widths, alignments and service lanes, etc, may be such that they are adequate as per the relevant Indian Road Congress Standards.
- c) Lane markings, kerb edges, central median, etc, may be provided for smooth movement of the traffic and also to guide the vehicles to stay within the designated driveways.
- d) Driveways may preferably be shaded by trees. The choice and appropriateness of selection of plants along the road should be in accordance with 7.
- e) Pedestrian crossings (on grade/subways/foot overbridges) may be provided along the pedestrian sidewalks at vehicular intersections to allow for continuous uninterrupted pedestrian movement.
- f) Pathways along vehicular roads may be physically separated by means of kerbs, graded separation, barrier, railing, or other means to prevent ingress of vehicles.
- g) Roads may be designed with provision for appropriate street furniture (*see 13* and other urban adjuncts for the convenience of the users). Benches, shelters, poles, signs, bus stops, etc, may be located on edge of the sidewalk with clear minimum width of 1.20 m to enable unhindered pedestrian circulation.

5.3 Open Spaces Design Guidelines for Ecologically Sensitive Zones and Historic Precincts

5.3.1 This category includes open spaces which may require interventions, such as reclamation, rehabilitation, restoration and/or redevelopment. These

kinds of open spaces may be broadly classified into the following types:

- a) *Ecologically sensitive zones*
 - 1) National sanctuary/nature park/reserve
 - 2) City forests
 - 3) Hills/ridge/rocky patches
 - 4) Open spaces governed by coastal regulation zone requirements including but not limited to beaches, estuaries, backwaters, lagoons, creeks, sandbars, salt pans, etc
 - 5) Wetlands, islands, river floodplains
 - 6) Urban landfill reclamations
 - 7) Greenways/Nature corridors
 - 8) Desert Edges and wastelands
- b) *Cultural and historic zones*
 - 1) Tea gardens, plantations and other special landscapes
 - 2) Existing rural landscapes
 - 3) Historic city centres and heritage structures
 - 4) Religious and culturally significant landscapes
 - 5) Sacred groves
 - 6) Zones inhabited by tribal settlements/indigenous communities
 - 7) Open spaces associated to historic precincts including but not limited to monuments, palace complexes, mausoleums, cemeteries, etc

5.3.2 Site Processes and Climatic Considerations

Whether designing to avoid impacts to a significant landscape area or to restore an ecological community, a detailed analysis may be conducted to understand the dominant site processes. The following processes may be considered:

- a) Topography;
- b) Hydrology;
- c) Biotic aspects (plants and animals);
- d) Biogeochemical processes; and
- e) Climatic considerations.

Stormwater adjacent to restoration areas may be managed to prevent any additional stormwater runoff to these areas. For water conservation practices, *see* Part 11 'Approach to Sustainability' of the Code, in addition to the following:

- 1) Surface water runoff may be directed towards designed bio-retention systems (for example, swales, rain gardens, or vegetated filters).

- 2) Wherever possible, stormwater may be used as a resource and the offsite impervious area water runoff may be captured so that this stormwater can be used where it is needed. Watershed impacts in landscape patches may be taken into cognizance during the design stages. Areas where upstream development may cause increased runoff may be designed with higher peak flows.
- 3) Planting areas may be incorporated so that they may capture and help in filtration and percolation of stormwater for ground water recharge.

5.3.3 *Design as a Response to the Existing Environment*

- a) Preservation of existing elements of value, such as mature trees, rocky outcrops, etc, may be considered.
- b) The historic precedents in the vicinity may be taken into consideration. Opportunities for passive recreation as well as active recreation may be considered so that it minimizes the impact on the natural condition of the open spaces especially in regional parks and city level parks encompassing large areas.
- c) The processes of site inventory, and site assessment and analysis may be done to confirm the value of the site which needs to be retained or preserved.
- d) The proposed usage of the site may be verified against the historical, cultural and ecological values of the site to ascertain the validity of the proposal.

5.3.4 *Designing and Locating Landscape Lighting*

- a) Haphazard placement of landscape light fixtures shall be avoided. The landscape light fixtures may be chosen from a pre-determined palette or designed so as to enhance and complement the character of the site.
- b) Light fixtures and fittings may be located in a sensitive manner so as to minimize the glare as well as prevent night sky pollution. *See 7.5* of Part 11 'Approach to Sustainability' of the Code.
- c) The height of light fixtures should be decided based on their spacing to prevent wastage of energy or creation of dark patches.
- d) Sturdy and durable light fixtures may be chosen to prevent vandalism.

5.3.5 *Protection and Conservation of Significant Landscape Areas*

- a) Barriers should be placed to prevent dumping

and to restrict vehicle access, wherever necessary.

- b) Hard surfaces, including bike trails and boardwalks may be developed and strategically placed so as to avoid dissecting, diminishing, or disturbing preservation areas.
- c) Opportunities for ecological and conservation research may be identified.

5.3.6 *Identification of Ecological Communities and their Connectivity*

- a) The type of vegetation community present, whether forest, shrub land, meadow, stream, tidal marsh or wetland, can guide the design for adjacent sites and the design and construction practices required to protect the community. Designers may familiarize themselves with the extent and history of the site. Imported soils, the elimination of a surface water source, or nutrient inputs may drastically change the structure and function of the site flora or fauna, and these changes may or may not be reversible.
- b) Surrounding areas for vegetation/wildlife movement opportunities or concerns to be explored. Linked parks may provide connectivity for plant species to spread seed and for smaller animals and birds to move. However, this may be both problematic and beneficial, as both desirable and undesirable species may spread.
- c) Native species may be encouraged to migrate to new areas by mimicking the conditions of successfully established habitat nearby. Barriers for the spread of invasive species may be created. Site disturbance adjacent to areas which harbour endemic species, may be minimized.

5.3.7 *Enhancement of Habitat Opportunities*

- a) Habitat areas may be established in those areas where human usage is compatible or acceptably low.
- b) Contiguous and dedicated open spaces may be established. The adjacent patches of species' habitat may be connected whenever possible, prioritizing areas adjacent to existing habitat for expansion.
- c) For river corridors, conditions that encourage fish migration may be enhanced. If there are upstream migration blockages, they may have to be removed.
- d) Planting areas that can capture stormwater may be included in the landscape. Native vegetation that is consistent with the site that

provides wildlife food may be planted. Vegetation along water edges for fish protection from predators may be provided.

5.3.8 Compliance with State Level, National Level and International River Revitalization Treaties, Coastal Management Program Policies, River Cleaning Missions, etc

- a) Underutilized areas may be restored.
- b) Water dependent and recreational uses may be minimized.
- c) Damage from flooding and erosion may be minimized using non-structural technologies.
- d) The consumption of natural resources may be minimized through efficient planning and design.
- e) Water quality standards should be adhered to and discharge of hazardous substances into coastal waters avoided.
- f) Compatible land uses with surrounding properties may be promoted.
- g) Impacts to navigable waters may be avoided.

5.3.9 Preservation of the Character of Existing Landscapes of Ecological and Culturally Significant Landscape Areas

- a) The history of a site, including original designs, past reconstructions, master plans and other development plans are important and shall be referred to understand and preserve important cultural landscapes.
- b) A cultural landscape report may be prepared if the landscape is historically important.
- c) Archeological investigation may be conducted, if found necessary.
- d) Sites with potential buried resources should be granted protection.
- e) For cultural landscapes, existing viewsheds may be preserved and enhanced through tree preservation, removal and replanting.

5.3.10 Design for Resilience and Ease of Maintenance

- a) Detailed as-built drawings that show locations of all hidden utilities of the external areas may be provided. The documents containing waterproofing and protection layer details should be provided to the maintenance team.
- b) Hose tapping points no more than 20 m from all planting areas may be provided to minimize hose-runs.
- c) The amount of funds for maintenance and manpower requirement for the external development zone may be assessed before initiating the design, and the design should be

commensurate with the maintenance budget.

- d) Manuals for equipment operation and maintenance, for tools, and for replacement parts may be provided, to be kept in a locked cabinet on site.
- e) Adequate training should be provided to all the operations personnel and gardeners.
- f) Preparation of a post-occupancy maintenance plan may be done in accordance with 7.1.2.3 of Part 11 'Approach to Sustainability' of the Code.

6 SIGNAGE

Signage shall be in accordance with Part 10 'Landscape Development, Signs and Outdoor Display Structures, Section 2 Signs and Outdoors Display Structures' of the Code.

7 PLANTING DESIGN

7.1 Plant material is a very important component of landscape development, and planting design is integral to any landscape plan. Designing with plants requires awareness and knowledge of a broad range of aspects including ecology, botany, horticulture, aesthetic value, growth and survival, and use of plants to address environmental and ecological concerns.

7.2 Plant Material

The major sets of factors that influence the choice of plant material are related to the characteristics, both botanical and physical of plant material and the context in which the plant material is to be used. The inter-relationship of these sets of factors is the basis for developing a sound approach to the process of designing with plants.

7.2.1 Physical and Botanical Characteristics of Plant Material

The information on plant material should be available in a systematic format to include definition, significance and design implications of the following aspects:

- a) Nomenclature (botanical and trade name);
- b) Origin, family and natural habitat;
- c) Growth characteristic and form as a function of habit;
- d) Physical characteristics, for example, bark texture, foliage, etc;
- e) Propagation and maintenance; and
- f) Use in landscape design.

7.2.2 Vegetation Types (Evergreen and Deciduous)

Some examples of the functional implications of using evergreen and deciduous plant material for specific situations are:

- a) *Evergreen trees*
 - 1) For places requiring shade throughout the year,
 - 2) For strong visual screening,
 - 3) As part of windbreak or shelter planting, and
 - 4) For areas where leaf litter is to be discouraged.
- b) *Deciduous trees*
 - 1) For greater visual variety,
 - 2) As partial visual barrier,
 - 3) For areas where under-planting is to be encouraged (for example, grass),
 - 4) For emphasis on branching and flowering pattern, and
 - 5) For areas where shade is not required throughout the year.

7.2.3 Growth Rate and Age of the Vegetation

Growth rate is directly related to the life-span of a tree and slower growing trees have a life-span extending to hundreds of years. The fast growing trees to the exclusion of slower growing varieties is not recommended. Landscapes are developed to sustain future generations; slow growing long lived native trees shall be emphatically included in all major planting schemes, specially those related to institutional campuses and large urban development. However, fast growing species have a limited role, and are appropriate in situations, where,

- a) quick effects are required, for example, in shelterbelts;
- b) immediate results with regards to stabilization of soil, etc are necessary, for example, in soil conservation schemes; and
- c) used as 'nurse plants' to protect slower growing sensitive species, when necessary.

The slower growing species would generally be appropriate in situations where sustained environmental benefits are required such as roadside planting, campuses, townships, industrial areas, and other public landscapes.

7.2.4 Growth Habits of Various Kinds of Vegetation and their Form

The overall physical form of a plant is usually the result of the foliage density and branching pattern. It may also be expressed as the proportionate relations between height and canopy spread. The latter is direct expression of growth habit.

A number of classifications of tree by their overall form exist, but it is almost impossible to have a variety

according to regional conditions. The following classification into basic types may be useful:

- a) *Trees of fastigiated or columnar habit* — Examples of trees of this type are:
 - 1) *Casuarina equisetifolia* (Beet-wood)
 - 2) *Grevillea robusta* (Silver oak)
 - 3) *Polyalthia longifolia* (Ashok)
 - 4) *Populus species* (Poplar)
 Though the branching pattern of each is different, the overall shape is similar.
- b) *Tall trees with broad canopy* — Examples of trees of this type are:
 - 1) *Dalbergia sissoo* (Sheesham)
 - 2) *Tamarindus indica* (Imli)
 - 3) *Terminalia arjuna* (Arjun)
 The canopy shape does not fit into any specific geometrical category.
- c) *Trees of spreading habit* — Examples of trees of this type are:
 - 1) *Delonix regia* (Gulmohar)
 - 2) *Lagerstromia flosreginae* (Pride of India)
 - 3) *Pithecolobium saman* (Rain tree)
 Though these trees vary greatly in size, their basic form is similar.
- d) *Trees of weeping habit* — Examples of trees of this type are:
 - 1) *Callistemon lanceolatus* (Bottle brush)
 - 2) *Salix babylonica* (Weeping willow)

The above classification is helpful in choosing various combinations of the above types to achieve desired function and visual objectives.

7.2.5 Foliage Characteristics of Plant Material

Visual effects imparted by vegetation, for example the perceived visual textures of plant forms depend on:

- a) *Leaf size and shape* — Examples of plants with large leaves and bold foliage texture are:
 - 1) *Neolamarckia cadamba* (Kadam)
 - 2) *Ficus lyrata* (Fig)
 - 3) *Plumeria acutifolia* (Temple tree)
 - 4) *Pterospermum acerifolium* (Kanak champa)
 Leaf shape can also determine the appearance of the foliage of the plant, as for example:
 - 1) *Callistemon lanceolatus* (Bottle brush) — Narrow leaves giving a feathery appearance
 - 2) *Polyalthia longifolia* (Ashok) — Long narrow leaves
 - 3) *Salix babylonica* (Weeping willow) —

Narrow leaves giving a feathery appearance

- b) *Leaf texture* — The textural appearance of a plant is the result of the play of light and shade on the foliage. Plants with larger leaves generally appear bolder in texture than smaller leaves plants as the areas of light and shade are larger and therefore more clearly differentiated.
- c) *Leaf and foliage colour* — Most trees in India have foliage in varying shades of green with variations in colour at the time of leaf fall and at the period when the tree is newly in leaf, when the leaves are fresh and much lighter in colour. Examples are:
 - 1) *Lagerstroemia speciosa* (Jarul) — Leaves acquire reddish tinge before falling
 - 2) *Polyalthia longifolia* (Ashok), *Delonix regia* (Gulmohar), *Erythrina indica* (India coral tree), etc — Leaves turn yellow before falling
 - 3) *Ficus infectoria* (Pilkhan), *Mangifera indica* (Mango) etc. — Young leaves have reddish tinge
- d) *Foliage density and distribution* — An important consideration is the way in which particular kinds of vegetation are perceived. Tree masses are usually seen from greater distance than shrub areas; foliage texture of different distinctive kinds of trees growing together has to be markedly distinctive for individual species to be recognizably apparent. In shrub areas subtle differences in foliage texture may suffice for creating the required visual effect.

7.2.6 Flowering Characteristics of Plant Material

7.2.6.1 Important considerations while identifying plant material according to flowering characteristics are as follows:

- a) Season,
- b) Density and distribution of flowers on the plant,
- c) Botanical characteristics of flowers (for example, single/cluster, etc),
- d) Colour, and
- e) Presence or absence of foliage during flowering period.

7.2.6.2 For the purpose of understanding the visual effect of flowers, tree species may be divided into two types:

- a) Trees on which flowers appear in profusion and therefore have a very strong visual impact,

for example, *Delonix regia*, *Cassia fistula*, *Lagerstroemia flosreginae*.

- b) Those on which flowers are less profuse, or perhaps last for a shorter period and visual impact is more subtle, for example, *Thespesia* spp., etc.
- c) *Aromatic/Non aromatic* — for example, *Plumeria* spp.

An additional consideration when choosing shrubs for their flowering quality is the visual appearance of the flowers themselves, as shrubs are usually seen from quite close. Distinctive flowers are those of,

- 1) *Beleperone guttata* (Shrimp plant)
- 2) *Hibiscus rosa-sinensis* (Climex hibiscus)
- 3) *Jasminum sambac* (Chameli)
- 4) *Tabernaemontana coronaria* (Cape jasmine)
- 5) *Thevetia peruviana* (Yellow oleander)

7.2.6.3 The olfactory characteristics, that is, odour, of flowers may be an added benefit of flowering plants. Flowers with distinctive scent include those of *Nyctanthes arbor-tristis* (Har-singar), *Jasminum pubescens* (Chameli), *Cestrum nocturnum* (Raat ki rani), etc.

7.2.6.4 Flowering characteristics of plant material may be classified as per the following format:

<i>Botanical Name</i>	<i>Characteristics of Flower</i>	<i>Seasonal Duration</i>	<i>Visual Impact</i>

7.2.7 Growth Requirement of Plant Material

Information about growth requirements of plant material applicable in landscape design pertains to the ability of particular plants to survive in specific environmental situations. These environmental conditions may arise from a number of aspects as given in **7.2.7.1** to **7.2.7.4**. Capacity of plants to grow in cultivated situations is related to the environmental conditions obtaining in their natural habitat.

7.2.7.1 Soil conditions

Physical as well as chemical properties of the available soil are important. These may or may not be amenable to change, they would therefore affect the choice of plant material considerably. Physical properties include consideration of light (for example, sandy) and heavy (for example, clayey) soils, and their structure. Chemical properties pertain to the presence or absence of nutrients and salts; soil, alkalinity or acidity. A preliminary soil analysis is essential for implementing effective planting schemes.

7.2.7.2 Availability and quality of water

The water requirement may be derived by data of humidity and rainfall of plants’ natural habitat. The water table of the area where the plantation is to be done has a crucial bearing on the design with plants as well as a financial implication for reduced maintenance if planted appropriately.

7.2.7.3 Availability of sunlight

The growth rate of plants is directly related to sunlight requirement and availability; such as plants that require: (a) full sunlight; (b) partial sunlight; (c) predominantly shade; and (d) complete shade.

7.2.7.4 Quality of air

Growth may be affected by chemical pollutants, such as sulphur dioxide or physical pollution such as dust. Certain plants have the ability to withstand pollution, such plants are imperative for industrial areas, roads, highways, etc.

7.2.8 Maintenance

The success of a designed landscape depends upon the growth of vegetation over an extended period of time; therefore maintenance of landscape is also a design component. Maintenance needs and practices in any given situation arise out of the inter-relationship between the growth requirements of plant material chosen and the environmental conditions existing on site.

The likely degree of maintenance should be assessed based on the following:

- a) Scale of the design project,
- b) Financial and manpower resource,
- c) Availability of manures,
- d) Future intensity of site, and
- e) Environmental conditions.

In small scale projects, such as gardens and small parks, the natural environmental conditions can be changed and maintained by management practices such as irrigation and application of fertilizers. The choice of plant species is therefore not very strictly limited by the existing environmental conditions. On larger scale schemes, such as very large parks, campuses and townships, this kind of intensive maintenance may not be possible. The process of choosing plants shall therefore respond to the existing environmental conditions, and also in such cases the choice of plant material is restricted by these conditions and suitable species become limited. The type of treatment adopted, as given below, may also serve as a guide to the degree of maintenance required:

a) Low maintenance	The lowest degree of maintenance is usually possible in areas treated with native species of trees only. A slightly higher degree is necessary where native shrubs are also used, as these may require pruning.
b) Medium	Areas treated with a mixture of native and exotic trees. Exotic shrubs and trees.
c) High	Exotic shrubs and ground covers. Lawns and maintained grass areas. Annual flowers and special schemes.

7.3 Functional Aspects of Design with Plants

Plant materials in landscape design may be used to,

- a) improve existing environmental conditions with respect to soil, drainage, microclimate, air pollution;
- b) create a designed physical environment through the organization of open space; and
- c) interpret and express the contemporary understanding of the man-nature relationship, that is, design with plants on an ecological rather than horticultural basis.

7.3.1 Choosing of Plant Material

Two sets of factors influence the choice of plant material in landscape design. One relates to information about plant material itself that determines the suitability of plant material from the point of view of growth requirements of plant material, and physical characteristics of the plant material. The second relates to the situation for which a planting proposal has to be made that pertains to the context in which the plant materials have to be used. Considerations of scale (that is, regional, local or very small scale situations), the existing environmental conditions, and functions which the plant material has to fulfill are important. Also the level of maintenance which is likely to be kept up, has to be considered which is especially important on very large sites. The biological history and ecological need of exotic plant should be studied prior to introduction in the landscape schemes to avoid the hazard of the species that may become invasive.

The factors determining choice of plant materials may be thus summarized as follows:

- a) *Environmental conditions existing on site* — These include climatic, soil characteristics, water table, etc.
- b) *Functions which plant material has to fulfill in specific situations on a given site* — These

may be either environmental functions (pertaining to improvement of soil conditions, modification or microclimate, etc) or design functions (relating to creating spaces enclosure, framing views, providing visual relief, etc).

- c) *Physical characteristics and growth requirements of plant material* — The former include foliage density, foliage texture, leaf size and shape, flower colour, rooting characteristics, etc. The latter include moisture requirements, whether the plant grows in sunny or shaded conditions, etc.

7.3.2 Methodology of Design with Plants

The process for designing with plants on a given site condition may be as per the format given below:

Zone	Chara- acteri- stics	Functions	Form	Species Chosen	Remarks
------	----------------------------	-----------	------	-------------------	---------

Plant material used in landscape design may be broadly classified as follows:

Plant Material	Classification
Tree	Large
	Medium
	Small
Shrub	Tall
	Low
Ground cover	Very low shrubs less than 300 mm high

7.3.3 Functions of Plant Material

7.3.3.1 Trees

Trees perform the following functions:

- a) Improvement in air quality,
- b) Increase in oxygen levels,
- c) Protection of soil,
- d) Modification in microclimate,
- e) Providing shade,
- f) Providing habitat for fauna,
- g) Providing enclosure,
- h) Providing direction and framing views,
- j) Screening,
- k) Providing visual relief,
- m) Reduction in noise levels,

- n) Acting as windbreaks and shelterbelts, and
- p) Providing fruits, seeds, etc, for consumption and therapeutic value.

NOTE — For functions of plants/shrubs to reduce noise, 3.6 of Part 8 ‘Building Services, Section 4 Acoustics, Sound Insulation and Noise Control’ of the Code may be referred.

7.3.3.2 Shrubs

The functions are similar to those of trees. Shrubs may be used together with trees to reinforce the functions, for example, noise barrier, shelterbelts, enclosures, etc.

Other forms in which shrubs may be used are as follows:

- a) *Hedges* — These require regular maintenance.
- b) *Shrubbery* — Here plants are allowed to retain their natural shape; they therefore require little maintenance.

Shrubs provide barriers, which may either be visual or physical (hedges). Barriers may be required in a range of situations, for example, they may be only for defining space, or they may be required for security and have to be, therefore, necessarily impenetrable.

7.3.3.3 Ground cover

Ground cover plants are those which naturally grow to a very low height. Some of the uses for which they may be used are:

- a) Stabilizing soil on steep slopes such as embankments.
- b) As a low maintenance substitute for grass (where the surface is not to be used).
- c) For providing variety in surface treatment.
- d) Contrast with paving materials, for example, to soften rigid lines of paving.
- e) As a subtle means of demarcating space, as for example, in places where tall plants would be visually intrusive.
- f) In combination with other plants to provide contrast or harmony in form.

7.3.3.4 Climbers

Certain climbers because of their spreading habits may also be used as ground cover (for example, *Asparagus* spp.). Also, climbers can increase the green cover without taking a lot of ground space. Climbers are useful for shading exposed walls from direct sunlight. They may also be used for stabilizing soil on embankments (for example, *Ficus stipulata*, *Ipomea biloba*). On sites where a high degree of security makes fencing necessary, climbers and spreading plants like *Bougainvillea* species, may be trained on boundary wall.

7.4 Planting for Shelter and Soil Conservation

The use of vegetation for controlling wind is widely recognized as an effective way of conserving soil and reducing erosion by wind. Vegetation may therefore be used for modifying the microclimate, by obstructing, guiding, deflecting or filtering wind current.

Vegetation areas designed to fulfill these general functions are usually classified as windbreaks and shelterbelts. Windbreak is grown protective planting around gardens and orchards. Windbreaks generally consist of single or double row of trees. Shelterbelt provides an extensive barrier of trees with several rows of trees. Plant species are chosen with particular regard to their physical and growth characteristics, and their effectiveness in achieving the desired results. Both windbreaks and shelterbelts have considerable visual impact in the landscape in which they are situated, they therefore need to be designed so that they make a positive visual and aesthetic contribution to their environment.

7.4.1 Function

Windbreaks and shelterbelts fulfill essential micro-climatic functions in rural and urban environments. Benefits accruing from plantation of shelter planting may be as follows:

- a) Reduction in wind velocity resulting in the arrest of movements of sand and soil particles.
- b) Prevention of soil erosion.
- c) Modification of micro-climate; moderation of change in air temperature.
- d) Protection of crops from being blown by high winds.
- e) Protection of livestock.
- f) Reduction in loss of soil moisture by evaporation.
- g) Increase in soil moisture due to greater dewfall in sheltered areas has been found to be 200 percent higher than on exposed ground; heaviest dew fall is over a distance of 2 to 3 times the height of the shelterbelt.
- h) Beneficial effect on growth of plants that are affected by high winds.
- j) Extensive shelterbelts may also be used to augment the supply of fuel in rural areas.
- k) The zone of influence of shelterbelt on crop yield extends to a distance of 20 times the height of the belt, with the maximum effect being observed 10 times the height of the tree belt, on the leeward side.

7.4.2 Wind Erosion

Some of the basic functions of windbreaks and

shelterbelts in arid and semi-arid areas are to conserve soil and reduce erosion by wind. The latter is a natural phenomenon in lands having very little rainfall (125 mm to 250 mm) and in areas adjoining a river, lake or sea. Wind erosion is a serious problem in areas where the ground is virtually bare and devoid of vegetation.

Factors which influence the degree and kind of wind erosion are as follows:

- a) *Features of wind* — Speed, direction, temperature, humidity, burden carried, etc.
- b) *Character of surface* — Rough or smooth plant cover, obstruction, temperature, etc.
- c) *Topography* — Flat, undulating broken, etc.
- d) *Character of soil* — Texture, organic matter, moisture content, etc.

7.4.2.1 Techniques for control of wind erosion

The principal method of reducing surface velocity of wind, upon which depends the abrasive and transportation capacity of wind, is by vegetation measures. Vegetation methods are found to be most effective in the form of windbreaks and shelterbelts. In aerodynamic terms, these provide protection as follows:

- a) Sheltered zone on the leeward side extends to approximately 15-30 times the height of the belt.
- b) A dense belt provides greater shelter immediately to leeward side but the sheltered area is not as extensive as when a more permeable zone of vegetation is provided.
- c) Porosity is important in the effectiveness of shelterbelt and proper selection of tree species is necessary. Porosity near ground level is desirable.
- d) Effectiveness of shelter planting depends more on height and permeability than on width. The width influences the general microclimate but above a certain minimum width, it does not affect greater reduction in wind velocity.

Protection obtained varies in relation to height (H) of shelterbelts, as given below:

<i>Distance</i>	<i>Wind Reduced by</i> Percent
H	90
$2H$	75
$5H$	50
$10H$	20

This indicates that it is better to have several windbreaks $5H$ to $6H$ apart rather than large forest stands with wide open spaces in between.

7.4.3 Profiles

A belt which rises and falls abruptly on windward and leeward sides is said to be more effective. Smaller trees and shrubs should occupy the inter-spaces between tall trees.

NOTE — Some authorities maintain that triangular section of shelterbelt planting can be more effective.

The depth of the shelterbelt should be approximately ten times its height. This is, however, only a thumb rule. Much lesser widths of 20 m to 30 m have also been found to be useful in particular situations; 15 m should be considered as minimum width.

Apart from factors such as climate, soil, fast rate of growth, one of the more significant considerations in choosing species for shelter planting is the possibility of a particular species serving the dual role of wood-production (for fuel, fodder) as well as shelter.

7.4.3.1 Spacing of plants in windbreaks and shelterbelts

Windbreaks usually consist of a single or multiple rows of trees planted closely according to species. Normally, one year old trees are used. As the roots of tree extend for some distance beyond the rows in which they are planted, the same should be taken into account while planting windbreaks. The most common layout where shelter planting is part of an extensive planned programme, is that of tree belts arranged in a chessboard pattern, each field being protected from every side. This pattern gives full protection to all the fields, provided that the right distance between the fields has been chosen. Efficient protection is achieved if belts are separated by a distance of not more than 20 times the height of the trees. A considerable mixture of species is recommended so as to compensate for different rates of growth and also to achieve variety in the form of crowns.

7.4.3.2 Within shelterbelts, close spacing of trees is the general practice. The recommended spacing for shrubs is 1 m and for tree such as *Casuarina* spp. and *Grevillia robusta* (Silver oak) 2.5 m. Spacing between rows should be 2.0 m to 4.0 m to enable mechanized cultivation. Five rows of tree and shrubs are considered necessary for proper protection.

7.4.4 Management

Shelterbelts should be regarded as living groups of trees to be managed in perpetuity and the following shall be taken into consideration for management thereof:

- a) Thinnings are limited to a strict minimum.
- b) Cutting is done individually by single tree selection method.
- c) Continuous cultivation may be required in areas with scanty rainfall.

- d) If individual trees do not survive, they should be replaced immediately to avoid gaps in the vegetation belt. The shelterbelt should be protected from cattle, either by fencing or by other means, especially in the early stages.

The location of shelterbelt may be related to local features such as public and private road networks, buildings, irrigation and water conservation works and methods of soil management practice (contour bunding, contour cultivation, etc). Careful choice of site will provide maximum protection to adjacent land and give shelter and shade.

The application of the concept of shelterbelts to landscape planning and design may be effective in the creation of landscape structure of very large developments at the regional scale, or townships or campuses. Shelterbelts can also be established in association with, or instead of road side planting. This itself creates a distinctive landscape pattern. The advantages of using native species in shelter planting are:

- a) New development is merged into the existing landscape. The original character of the landscape is therefore not obtruded upon.
- b) The shelterbelt is a component of land management (previous waste or barren land is conserved).
- c) Additional habitat for wildlife are brought into existence.

7.4.5 Species suitable for windbreaks are:

- a) *For dry and arid regions*
 - 1) *Ailanthus excelsa* (Maharukh)
 - 2) *Albizia lebbbeck* (Siris)
 - 3) *Azadiracta indica* (Neem)
 - 4) *Casuarina equisetifolia* (Beef-wood)
 - 5) *Dalbergia sissoo* (Sisham)
 - 6) *Eugenia jambolana* (Jamun)
 - 7) *Grevillea robusta* (Silver oak)
 - 8) *Peltophorum ferrugineum* (Cooper pod)
 - 9) *Tamarindus indica* (Imli)
 - 10) *Pongamia glabra* (Indian beech)
 - 11) *Tamarix articulata* (Tamarisk)
- b) *For coastal areas*
 - 1) *Anacardium occidentale* (Cashew)
 - 2) *Ailanthus triphysa* (Halmaadi)
 - 3) *Casuarina equisetifolia* (Beef-wood)
 - 4) *Pongamia glabra* (Indian beech)
 - 5) *Sesbania aculeata* (Sesban)
 - 6) *Thevetia peruviana* (Yellow oleander)
 - 7) *Thespesia populnea* (Indian tulip)
 - 8) *Vitex negundo* (Sephali)

7.5 Air Pollution Control by Plants

Air pollution may be caused by areas or point sources such as cities, burning of wastes, industrial emissions, factories, construction activities or by linear sources such as highways. Vegetation buffers can minimize the build-up of pollution levels in urban areas, by acting as pollution sinks.

Studies have established that air pollution, smoke and sulphur dioxide leads to an exacerbation of chronic respiratory diseases and they are linked to increased risks of lung cancer, pneumonia, tuberculosis, chest disease in children, stomach cancer and cardiovascular diseases. Lead from vehicle exhausts may have an adverse effect on mental health of children, asbestos from disintegrating clutch and brake linings has been considered as a causal factor in lung cancer.

7.5.1 Effect of Plants

Plant leaves function as efficient gas exchange systems. Their internal structure allows rapid diffusion of water-soluble gases. These characteristics allow the plant to respire and photosynthesize, and they can also remove pollutant from the air. Some of the beneficial results of plantations may be:

- a) They are good absorbers of sulphur dioxide.
- b) Parks with trees have sulphur dioxide level lower than city streets.
- c) Roadside planting can reduce traffic generated air borne lead, on leeward side.
- d) Heavy roadside planting in the form of shelterbelts can result in a reduction in airborne lead.
- e) Complete dust interception can be achieved by a 30 m belt of trees. Even a single row of trees may bring about 25 percent reduction in airborne particulate.

7.5.2 Choosing Plants

The three main criteria for selection of plants may be:

- a) Trees, shrubs should have a dense foliage with a large surface area, because leaves reduce pollutants.
- b) Evergreen trees are found to be more effective.
- c) The species chosen should be resistant to pollutants, particularly in the early stages of their growth.

The following species may be examined for their likely potential for pollution control:

- 1) *Acacia arabica* (Babul),
- 2) *Citrus* spp.,
- 3) *Diospyros* spp.,

- 4) *Ficus bengalensis* (Banyan),
- 5) *Ficus religiosa* (Peepal),
- 6) *Lilium* spp. (Lily),
- 7) *Polyalthia longifolia* (Ashok),
- 8) *Tamarindus indica* (Imli),
- 9) *Thuja occidentalis* (Cedar),
- 10) *Prosopis juliflora* (Mesquite), and
- 11) *Zizyphus jujuba* (Jujuba), etc.

Filtering of pollutants is most effective when plants are close to the source of pollution. The design of shelterbelts against pollution is similar to those for protection from wind. They should be permeable to encourage air turbulence and mixing within the belt. There should be no large gaps. The profile should be rough and irregular and should present a tall vertical leading edge to the wind. Spaces should be left within the shelterbelt to allow gravity settlement of particles.

7.5.3 Applications

Air pollution shelterbelts maybe used to protect sensitive land uses from air pollution. For instance school playgrounds, children play area and residential estates close to major roads may be so protected. Shelterbelt protection may also be provided for hospitals, institutions, etc, where the vegetation may also be a visual screen and a partial noise barrier. Vegetation may also be used where the existing means of pollution control have proved inadequate.

8 SPECIFICATIONS FOR PLANTING WORKS

The requirements relating to plant materials and other materials; execution of work of tree planting, shrub planting and grassing; maintenance; etc, shall be as given in **8.1** to **8.6**. The contractor shall furnish all materials, labour and related items necessary to complete the work indicated on drawing and specified herein and shall carry out maintenance of the premises for 12 months after completion of the work or as specified by the landscape architect.

8.1 Materials

8.1.1 Plant Materials

Plant materials shall be well formed and shaped true to type, and free from disease, insects and defects such as knots, windburn, injuries, abrasion or disfigurement. All plant materials shall be healthy, sound, vigorous, free from disease, insect pests, or their eggs, and shall have healthy, well-developed root systems. All plants shall be hardy under climatic conditions similar to those in the locality of the project. Plants supplied shall conform to the names listed on both the plan and the plant list. No plant material shall be accepted if

branches are damaged or broken. All material shall be protected from sun and adverse weather until planted. Nursery stock shall be inspected and approved by the landscape architect and the horticulturist/botanist shall do the botanical authenticity of the selected species.

All plants shall conform to the requirements specified in the plant list, except those plants larger than specified may be used if approved, but use of such plants shall not increase the contract price. If the use of the larger plant is approved, the spread of roots or ball of earth shall be increased in proportion to the size of the plant. Plants shall be delivered with legible identification labels.

The minimum acceptable size of all trees after pruning, with branches in normal positions, shall conform to the measurement specified in the bill of quantities unless stated otherwise. Caliper measurement shall be taken at a point on the trunk 1.0 m above natural ground. All trees supplied shall have terminal shoots. All specimen trees shall have a minimum crown spread of not less than half the size of the overall height.

8.1.2 Topsoil (Good Earth) with pH Range between 6.5 and 7.5

Topsoil or good earth shall be a friable loam; typical of cultivated top soils of the locality contains at least 2 percent of decayed organic matter (humus). It shall be taken from a well-drained arable site. It shall be free of subsoil, stones, earth clods, sticks, roots or other objectionable extraneous matter or debris. It shall contain no toxic material. No topsoil shall be delivered in a muddy condition.

Top soil in the project area shall be stripped, stacked, stored and used for filling on completion of construction.

8.1.3 Fertilizer

Dry farm yard manure shall be used. It shall be free from extraneous matter, harmful bacteria, insects or chemicals.

8.1.4 Root System

The root system shall be conducive to successful transplantation. Where necessary, the root-ball shall be preserved by support with hessian or other suitable material. On soils where retention of a good ball is not possible, the roots should be suitably protected in some other way which should not cause any damage to roots.

8.1.5 Condition

Trees and shrubs shall be substantially free from pests and diseases, and shall be materially undamaged. Torn or lacerated roots shall be pruned before dispatch. No roots shall be subjected to adverse conditions, such as

prolonged exposure to drying winds or subjection to water logging, between lifting and delivery.

8.1.6 Marking

Each specimen of tree and shrub, or each bundle, shall be legibly labelled with the following:

- a) Its name;
- b) Name of the supplier, unless otherwise agreed; and
- c) Date of dispatch from the nursery.

8.2 Execution

8.2.1 Fine Grading

Grades should be smooth and even on a uniform plane without abrupt changes or pockets and slope away from the buildings. The nominated landscape contractor should verify the surface drainage of planting areas and notify the landscape architect of any discrepancies, obstructions or other conditions considered detrimental to proper execution of the work and plant growth.

8.2.2 Landscape work should be tied to the existing condition such as existing trees, landscape features, utility lines, pavement kerbs. Finished grade should bear proper relationship to such control. The nominated landscape contractor shall adjust all works as necessary to meet the conditions and fulfill the intention of the drawings. After initial settlement the finish grade should be as follows:

- a) Turf : 20 mm lower than adjacent walks/kerbs.
- b) Shrubs and ground covers : 40 mm lower than adjacent walks/kerbs.

Prior to planting operation, the contractor should ensure all planting areas free of weeds, debris, rocks over 25 mm in diameter and clumps of earth that do not break up.

8.3 Tree Planting

8.3.1 Trees should be supplied with adequate protection as approved. After delivery, if planting is not to be carried out immediately, balled plants should be placed cheek to cheek and the ball covered with sand to prevent drying out. Bare rooted plants can be heeled in by placing the roots in a prepared trench and covering them with earth which should be watered in to avoid air pockets round the roots.

8.3.2 Digging of Pits

Tree pits shall be dug a minimum of three weeks prior to backfilling. The pits shall be 1 200 mm in diameter and 1 200 mm deep. While digging the pits, the topsoil up to a depth of 300 mm may be kept aside, if found

good (depending upon site conditions), and mixed with the rest of the soil. If the soil is bad below, it shall be replaced with the soil mixture as specified further herein. If the soil is normal it shall be mixed with manure; river sand shall be added to the soil if it is heavy.

8.3.3 Flooding of Pits to Reduce Air Pockets

The soil backfilled, watered through and gently pressed down, a day previous to planting, to make sure that it may not further settle down after planting. The soil shall be pressed down firmly by treading it down, leaving a shallow depression all round for watering.

8.3.4 Planting

No tree pits shall be dug until final tree positions have been pegged out for approval. Care shall be taken that the plant sapling when planted is not buried deeper than in the nursery, or in the pot. Planting should not be carried out in water logged soil. Trees should be planted up to the original soil depth; the soil marks on the stem is an indication of this and it should be maintained on the finished level, allowing for setting of the soil after planting. All plastic and other imperishable containers should be removed before planting. Any broken or damaged roots should be cut back to sound growth.

The bottom of the planting pit should be covered with 50 mm to 75 mm of soil. Bare roots should be spread evenly in the planting pit; and small mound in the centre of the pits on which the roots are placed will aid an even spread. Soil should be placed around the roots, gently shaking the trees to allow soil particles to shift into the root system to ensure close contact with all roots and to prevent air pockets. Back fill soil should be firm as filling proceeds, layer by layer, care being taken to avoid damaging the roots.

8.3.5 Staking

Newly planted trees shall be held firmly although not rigidly by staking to prevent a pocket forming around the stem and newly formed fibrous roots being broken by mechanical pulling as the tree rocks.

The main methods of staking shall be:

- a) A single vertical stake, 900 mm longer than the clear stem of the tree, driven 600 mm to 900 mm into the soil.
- b) Two stakes as above driven firmly on either side of the tree with cross-bar to which the stem is attached (suitable for small bare-rooted or balled material).
- c) A single stake driven in at an angle 45° and leaning towards the prevailing wind, the stem just below the lowest branch being attached to the stake (suitable for small bare-rooted or balled material).

- d) For plant material 3 m to 4.5 m high with a single stem, a three-wire adjustable guy system may be used in exposed situations.

The end of stake should be pointed and the lower 1.0 m to 1.2 m should be coated with non-injurious wood preservative allowing at least 150 mm above ground level.

8.3.6 Tying

Each tree should be firmly secured to the stake so as to prevent excessive movement. Abrasion shall be avoided by using a buffer, rubber or hessian, between the tree and stake. The tree should be secured at a point just below its lowest branch, and also just above ground level; normally two ties should be used for tree. These should be adjusted or replaced to allow for growth.

8.3.7 Watering

The contractor should allow for the adequate watering in all newly planted trees and shrubs immediately after planting and shall, during the following growing season, keep the plant material well-watered.

8.4 Shrub Planting in Planters and Beds

All areas to be planted with shrubs shall be excavated, trenched to a depth of 750 mm, refilling the excavated earth after breaking clods and mixing with manure in the ratio 8 : 1 (8 parts of stacked volume of earth after reduction by 20 percent; 1 part of stacked volume of manure after reduction by 8 percent).

Tall shrubs may need staking, which shall be provided if approved by the landscape architect depending upon the conditions of individual plant specimen.

For planting shrubs and ground cover shrubs in planters, good earth shall be mixed with manure in proportion as above and filled in planters.

Positions of shrubs to be planted should be marked out in accordance with the planting plan. When shrubs are set out, precautions should be taken to prevent root drying. Planting holes 400 mm in diameter and 400 mm deep should be excavated for longer shrubs. Polythene and other non-perishable containers should be removed and any badly damaged roots carefully pruned. The shrubs should then be set in holes so that the soil level, after settlement, will be at the original soil mark on the stem of the shrub. The hole should be back-filled to half its depth and firmed by treading. The remainder of the soil may then be returned and again firmed by treading.

8.5 Grassing

8.5.1 Preparation

During the period prior to planting, the ground shall

be maintained free from weeds. Grading and final levelling of the lawn shall be completed at least three weeks prior to the actual sowing. Regular watering shall be continued until sowing by dividing the lawn area into portions of approximately 5 m² by constructing small bunds to retain water. These bunds shall be levelled just prior to sowing of grass plants. At the time of actual planting of grass, it shall be ensured that the soil has completely settled.

8.5.2 Soil

The soil itself shall be ensured to the satisfaction of the landscape architect to be a good fibrous loam, rich in humus.

8.5.3 Sowing the Grass Roots

Grass roots shall be obtained from a grass patch, seen and approved beforehand. The grass roots stock received at site shall be manually cleared of all weeds and water sprayed over the same after keeping the stock in a place protected from sun and dry winds. Grass stock received at site may be stored for a maximum of three days. In case grassing for some areas is scheduled for a later date fresh stock of grass roots shall be ordered and obtained. Small roots shall be dibbled about 75 mm apart into the prepared grounds. Grass areas will only be accepted as reaching practical completion when germination has proved satisfactory and all weeds have been removed.

8.5.4 Maintenance of Grassing

As soon as the grass is approximately 30 mm high, it shall be rolled with a light wooden roller in fine, dry weather. When it has grown to 50 mm to 80 mm above ground, weeds shall be removed and regular cutting with a scythe and rolling shall be then begun. A top-dressing of farm yard manure, bone meal at the rate of 50 g/m² and NPK (Nitrogen, phosphorus and potassium fertilizer) at the rate of 10 g/m² shall be applied when the grass is sufficiently secure in the ground to bear the mowing machine, the blades shall be raised 25 mm above the normal level for the first two or three cuttings. That is to say, the grass should be cut so that it is from 40 mm to 50 mm in length, instead of the 30 mm necessary for mature grass.

In the absence of rain, during monsoon, the lawn shall be watered with sprinklers, every three days, soaking the soil to a depth of at least 200 mm. Damage, failure or dying back of grass due to neglect of watering specially for seeding out of normal season shall be the responsibility of the contractor.

Any shrinkage below the specified levels during the contract or defects liability period shall be rectified at the contractor's expense. The contractor shall exercise care in the use of rotary cultivator and mowing

machines to reduce to a minimum the hazards of flying stones and brickbats. All rotary mowing machines are to be fitted with safety guards.

8.5.5 Rolling

Lawn mower with roller shall be used periodically, taking care that the lawn is not too wet and sodden.

8.5.6 Edgings

These shall be kept neat and shall be cut regularly with the edging shears.

8.5.7 Watering

Water shall be applied at least once in three days during dry weather. Whenever watering is done, it should be thorough and should wet the soil at least up to a depth of 200 mm.

8.5.8 Weeding

Prior to regular mowing, the contractor shall carefully remove rank and unsightly weeds.

8.6 Maintenance

8.6.1 The landscape contractor shall maintain all planted areas within the landscape contract boundaries for one year until the area is handed over in whole or in phases. Maintenance shall include replacement of dead plants, watering, weeding, cultivating, control of insects, fungus and other diseases by means of spraying with an approved insecticide or fungicide, pruning, and other horticulture operations necessary for the proper growth of the plants and for keeping the landscape contract area neat in appearance.

8.6.2 Pruning and Repairs

Upon completion of planting work under the contract, all trees should be pruned and all injuries repaired, where necessary. The amount of pruning shall be limited to the minimum necessary to remove dead or injured twigs and branches, and to compensate for the loss of roots and result of transplanting operations.

Pruning and removal of any part of plant materials should be done with clean sharp tools. Tools used to carry out the pruning work shall be appropriate for the task. The surface of tools and equipment shall be sterilized after use on the plant materials that are suspected or known to be diseased. Cuts on plant materials shall be made into the living tissues to induce callousing. Cut surface shall be flat, sharp and without jagged or torn edges.

Pruning shall be done in such a manner as not to change the natural habitat or special shape of the trees. Pruning operation shall consider carefully the natural growth pattern of branches on the tree, palm or shrub. Tree branches shall be pruned back to the collar at the base of the branch.

8.6.3 Tree Guards

Where tree guards are necessary, care should be taken to ensure that they do not impede natural movement or restrict growth.

8.6.4 Nursery Stock

Planting should be carried out as soon as possible after reaching the site. Where planting needs to be delayed, care should be taken to protect the plants from pilfering or damage from people or animals. Plants with bare roots should be heeled-in as soon as received or otherwise protected from drying out, and others set closely together and protected from the wind. If planting needs to be delayed for more than a week, packed plants should be unpacked, the bundles opened up and each group of plants heeled-in separately and clearly labelled. If for any reason the surface of the roots becomes dry, the roots should be thoroughly soaked before planting.

8.6.5 Protective Fencing

According to local environment, shrubs shall be protected adequately from vandalism, until established.

8.6.6 Routine Maintenance Work Schedule

<i>Sl No.</i>	<i>Operation</i>	<i>Frequency</i>
(1)	(2)	(3)
i)	Watering	Checking all planting areas and pits and water as often as necessary to ensure that planting material does not dry out
ii)	Weeding	Monthly
iii)	Edging	Monthly
iv)	Fertilizing:	
	a) Trees/palms	Once every three months
	b) Shrubs/ground covers	Monthly
	c) Grass	Once every three months
v)	Loosening of soil	Monthly
vi)	Control of pest by applying appropriate insecticides	Fortnightly
vii)	Control of disease by applying appropriate fungicides	Monthly, increasing the frequency to fortnightly during rainy season
viii)	Grass cutting	Fortnightly
ix)	Pruning and shaping trees/palms	Once every six month for small and low sagging branches
x)	Staking	As and when required
xi)	Trimming shrubs/ground covers	Monthly or as when required

8.6.7 Clean-Up Works

There shall be areas designated by landscape architect for the contractor to carry out clean-up works. These shall include the following:

- a) Removal of dead and/or overhanging branches of existing trees, palms, shrubs and ground covers.
- b) Removal of any garbage and unsightly foreign materials.
- c) Removal of dead vines and plant materials.

The contractor shall prevent damages to the existing plant materials, identified to be conserved. The plant materials that are to be conserved if damaged beyond use during the clean-up operations, the contractor shall be liable to replace the plant materials at his expense.

8.6.8 Restoration

The contractor is responsible for the use of all materials, labour and equipment and any injury to the plant material, labour and equipment shall be repaired or the same replaced by the contractor at his own expense.

8.6.9 Completion

On completion, the ground shall be formed over and left tidy.

9 SERVICE/UTILITIES IN LANDSCAPE DEVELOPMENT

9.1 Designed integration of structures and elements related to external services (underground and over ground utilities) with landscape is most essential for any outdoor space. This may, therefore, be taken care of in conjunction with the provisions under Part 4 ‘Fire and Life Safety’, Part 8 ‘Building Services’, Part 9 ‘Plumbing Services’ and Part 11 ‘Approach to Sustainability’ of the Code.

The following services, generally, are the subject of design coordination work for external areas:

- a) *Stormwater drainage*
 - 1) Stormwater network;
 - 2) Open drain and swale;
 - 3) Subsurface drainage system;
 - 4) Catch basin and manholes;
 - 5) Culvert and bridge;
 - 6) Percolation pits;
 - 7) Water harvesting units;
 - 8) Retention walls and tanks;
 - 9) Connection of all service lines up to out-fall; and
 - 10) Other related structures.

- b) *Sewage disposal system*
 - 1) Sewerage network;
 - 2) Manholes, inspection chambers and grease trap;
 - 3) Septic tank, soak-pits, sewage treatment plant and root zone unit;
 - 4) Solid waste management units;
 - 5) Connection of all service lines up to out-fall; and
 - 6) Other related structures.
- c) *Water supply (including irrigation)*
 - 1) Water supply network;
 - 2) Inspection chamber and valve chamber;
 - 3) Water tank and treatment plant;
 - 4) Tube well, bore well and associated pump houses, etc;
 - 5) Service lines, elements associated with water features and pools; and
 - 6) Irrigation lines and allied requirements.
- d) *Fire lines*
 - 1) Yard hydrant lines;
 - 2) Yard or fire hydrants and hose reel box;
 - 3) Fire water tank and pumps; and
 - 4) Inspection chamber and valve chamber.
- e) *Electrical works*
 - 1) Electrical network;
 - 2) Light fixtures for road, pedestrian paths, special landscape features and building façade;
 - 3) Inspection chambers, junction boxes and feeder pillars;
 - 4) Electric poles, high voltage lines and towers;
 - 5) Transformer, substation and distribution box; and
 - 6) Other related structures.
- f) *Telephone and underground cable network*
 - 1) Telephone network;
 - 2) Inspection chambers;
 - 3) Telephone poles, transmission towers; and
 - 4) Other related structures.
- g) *Fuel and gas line*
 - 1) Supply network;
 - 2) Inspection chamber and valve chamber;
 - 3) Fuel tank and gas tank; and
 - 4) Other related structures.
- h) *HVAC*
 - 1) Ventilation shafts for basement ventilation; and
 - 2) Chiller and cooling towers.

9.1.1 The following guidelines shall be applied for the designed integration of external services networks and elements in the landscape proposal:

- a) Manholes and inspection chamber covers for all external services should be adequately designed for the imposed load (pedestrian or vehicular) and the top finish level has to be in alignment or flushed with the pavement or finished ground level. The alignment of these structures should be such that it is in geometric perpendicular or parallel with adjacent building or landscape lines. This would facilitate easy and unobstructed movement for pedestrians and increase the accessibility for wheelchair users in public place and also aid the landscape geometry to be maintained.
- b) Fire hydrants should be prominently located and integrated with the landscape. Aesthetically designed fire hose cabinet with clear access as per statutory norms for fire safety, to be located in geometric relation with adjacent building or landscape lines. These structures should not be a hindrance to vehicular or pedestrian movement.
- c) Irrigation hydrants should be unobtrusively located and generally at the edge of shrub planting and additionally in close proximity to a drainage chamber or catch basin to avoid waterlog. Hydrants should not be located inside the chamber to minimize waterlog from leaking pipes causing various health related hazards. Hydrants should be located 200 mm above the ground level.
- d) Landscape lighting is a specialized activity and illumination consultant or designer should develop the landscape lighting plan taking into consideration energy saving measures, safety aspects, lighting pollution and illumination level. Light fixtures are an important part of street furniture and it is advisable to use pole mounted light fixtures for public landscape than bollards that are prone to vandalism and damage.
- e) Water body and fountains in public spaces should have filtration facility to avoid health hazards related to stagnant water. The piping should be concealed and the pump room, balancing tank and all other service structures to be designed as an integral part of landscape.
- f) Storage facilities for inflammable liquid fuel and gas should be designed as an integral part of the landscape and should be housed in designed enclosures taking into consideration all statutory norms these structures are subjected to.

- g) All underground service lines have to be well coordinated and stacked appropriately in the design stage to avoid overlaps and marked with indicators above the ground for ease in maintenance and servicing. Underground service stacks should be generally aligned in soft areas with no tree plantation, this would facilitate easy maintenance without disrupting the hard surface.
- h) Designed façade for service structures that are above the ground in external areas is advisable so as to assist in developing aesthetically pleasing exterior environment. Such structures should be designed in a modular way so that it would be part of the street furniture.

10 ROOF LANDSCAPE

10.1 Green roof design include the following:

- a) Understanding the structural stability and load bearing capacity (dead and imposed loads) of roof. The structural loading is a combination of dead loads; all permanently placed parts of the roof, including hardscape, plants, growing medium, features, etc; and the imposed loads, such as people and temporary components.
- b) Waterproofing of the structure and the green areas.
- c) Arrangement of surface and subsurface drainage of the roof.
- d) Soil fill, and planting with limited root zone.
- e) Location and planting of trees.
- f) Location and design of pavements, walls, landscape features and structures.

10.2 Design Guidelines

The guidelines given below shall be followed for the design of green roofs (*see* Fig. 1)

- a) *Screed* — A concrete layer shall be laid on the roof slab to provide slopes for subsurface drainage of vegetated areas, drains. Where there is a large green area on the roof, perforated pipes laid in screed shall be used to channelize subsurface water to the adjoining drainage chambers.
- b) *Waterproofing membrane* — A protective layer shall be laid on the sloped concrete surface to protect the building's structure and the waterproofing membrane on the building slab.
- c) *Drainage* — Drainage shall comprise of surface drainage and subsurface drainage. Subsurface drainage layer shall be very porous to permit water to pass easily through it. It

should be permanent and continuous over the entire roof surface and strong enough to support the weight of the plant materials and hardscape above it. This layer shall be kept free of any materials that could prevent the free flow of water to the drains. Drainage cells may be used to increase soil depth. Surface drainage shall allow for easy flow of water from the roof surface to the drainage chambers on grade. It shall comprise of drains, catch basins. They shall be carefully designed to avoid expansion joints on the roof.

- d) *Filter membrane* — Helps in containing the roots and the growing medium, while allowing for water penetration and prevents clogging of the drainage layer and roof drains.
- e) *Soil* — Shall be as described in 8.1.2. The depth of soil shall depend on type of planting, screed thickness and structural allowance for fill above slab.
- f) *Vegetation* — Shall be grass, shrubs, ground covers, trees. Type of vegetation shall depend on the structural allowance for fill above slab.
- g) *Irrigation* — Shall be adequately provided. The thin depth and well-drained soil used in green roof construction cannot provide the plantings with the subsurface water normally available to ground level plantings. Care shall be exercised to prevent the soil mass from drying out and causing damage to the plant materials.
- h) *Services/Utilities* — As described in 9.1 shall be integrated with the landscape
- j) *Hardscape* — Includes paving, street furniture and water features, walls, fences, screens, pergolas, kerbs, fire paths, roads. The landscape elements shall be considered in relationship to the structural limitations of the roof and its supports below. The street furniture, including lighting fixtures shall be carefully anchored on rooftops.

11 PROTECTION OF LANDSCAPE DURING CONSTRUCTION

Development projects involve disturbance to the existing soil conditions, removal of existing trees and overall change in the microclimate and drainage pattern. Measures to minimize hazardous effects should be put into effect as explained below.

11.1 Pre-Construction Measures

Measures for the prevention of soil erosion, sediment control and management of stormwater shall be implemented as given in 11.1.1 to 11.1.5.

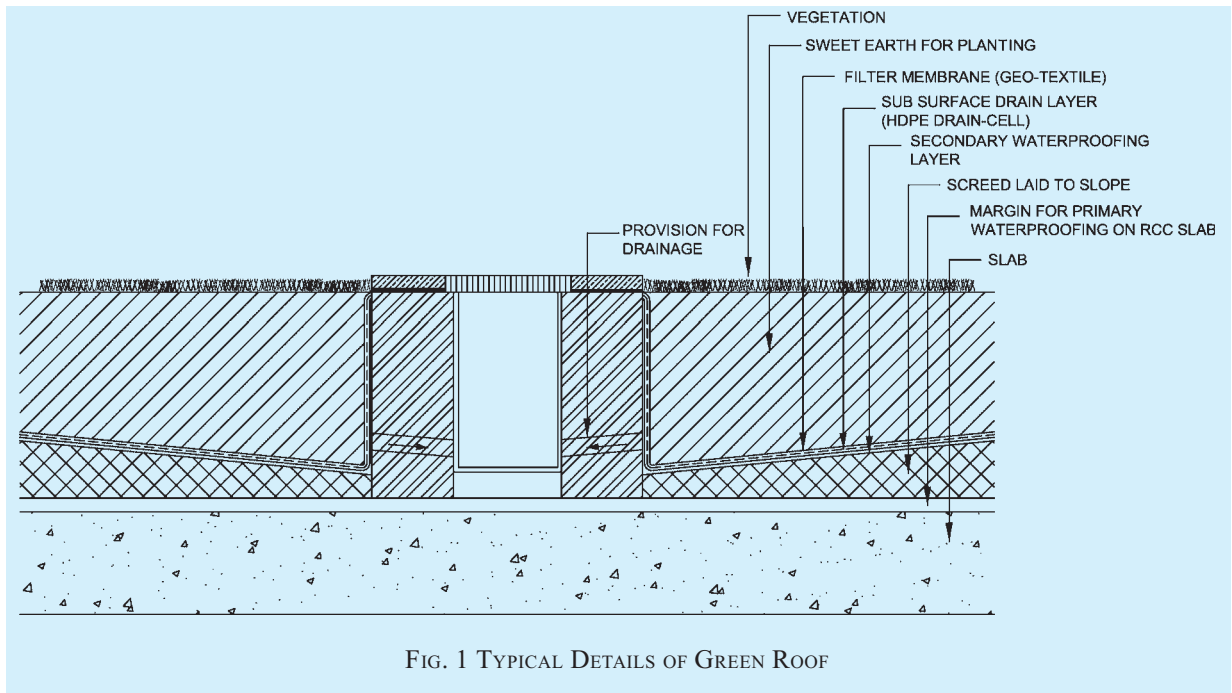

11.1.1 Timing of Construction

Construction work and erosion control applications shall be scheduled and sequenced during dry weather periods when the potential for erosion is the lowest. Slope protection techniques to control erosion shall be used when construction during wet season is unavoidable. Sedimentation collection systems, drainage systems, and runoff diversion devices shall be installed before construction activity. The landscape architect/engineer-in-charge shall monitor the site conditions and progress of work and schedule appropriate timing and sequencing of construction.

11.1.2 Preservation of Existing Vegetation

11.1.2.1 Protection of existing vegetation (including trees, shrubs, grasses and other plants) where possible, by preventing disturbance or damage to specified areas during construction is recommended. This practice minimizes the amount of bare soil exposed to erosive forces. All existing vegetation shall be marked on a site survey plan. A tree survey in prescribed format shall be carried out as indicated in Table 3.

Table 3 Plant Material Schedule for Tree Survey
(Clause 11.1.2.1)

Sl No.	Tree No.	Botanical Name	Common Name	Girth mm	Height mm	Spread mm	Condition
(1)	(2)	(3)	(4)	(5)	(6)	(7)	(8)

The landscape plan should indicate trees, which have

been preserved, and also those, which had to be transplanted or removed clearly differentiating between these three categories.

11.1.2.2 Trees retained on the project site shall be protected during the construction period by following measures:

- a) Damage to roots shall be prevented during trenching, placing backfill, driving or parking heavy equipment, dumping of trash, oil, paint, and other materials detrimental to plant health by restricting these activities to outside the area of the canopy of the tree.
- b) Trees shall not be used for support; their trunks shall not be damaged by cutting and carving or by nailing posters, advertisements or other material.
- c) Lighting of fires or carrying out heat or gas emitting construction activity within the ground, covered by canopy of the tree shall not be permitted.
- d) Young trees or saplings identified for preservation (height less than 2.00 m, 0.10 m trunk girth at 1.00 m height from finish ground, 2.00 m crown diameter) within the construction site have to be protected using tree guards of approved specification.
- e) Existing drainage patterns through or into any preservation area shall not be modified unless specifically directed by the landscape architect/engineer-in-charge.
- f) Existing grades shall be maintained around existing vegetation and lowering or raising the

levels around the vegetation is not allowed unless specifically directed by the landscape architect/engineer-in-charge.

- g) Maintenance activities shall be performed as needed to ensure that the vegetation remains healthy.
- h) The preserved vegetated area shall be inspected by the landscape architect/engineer-in-charge at regular intervals so that they remain undisturbed. The date of inspection, type of maintenance or restorative action followed shall be recorded in the logbook.

11.1.3 Staging Areas

Measures shall be followed for collecting runoff from construction areas and material storage sites; diverting water flow away from such polluted areas, so that pollutants do not mix with stormwater runoff from undisturbed areas.

Temporary drainage channels, perimeter dike/swale, etc, shall be constructed to carry the pollutant-laden water directly to treatment device or facility. The plan shall indicate how the above is accomplished on site, well in advance of the commencing of the construction activity.

11.1.4 Preservation of Topsoil

Topsoil removal and preservation shall be mandatory for development projects larger than 1.00 hectare. Topsoil shall be stripped to a depth of 200 mm from areas proposed to be occupied by buildings, roads, paved areas and external services. Topsoil is rich in organic content and is essential to establish new vegetation. It shall be stockpiled to a height of 400 mm in designated areas and shall be reapplied to site during plantation of the proposed vegetation. Topsoil shall be separated from subsoil debris and stones larger than 50 mm diameter. The stored topsoil may be used as finished grade for planting areas.

11.1.5 Spill Prevention and Control

Spill prevention and control plans shall be made, clearly stating measures to stop the source of the spill, to contain the spill, to dispose the contaminated material and hazardous wastes, and stating designation of personnel trained to prevent and control spills. Hazardous wastes include pesticides, paints, cleaners, petroleum products, fertilizers and solvents.

11.2 Measures During Construction

During construction soil becomes unconsolidated due to removal of stabilizing material such as vegetation and disturbance of stabilized existing grade resulting in loss of topsoil and also deposition in undesirable places. A soil erosion and sedimentation control plan

to be prepared prior to construction. The soil erosion, sediment control and stormwater practices should be considered whilst construction is proceeding, in accordance with 11.2.1 to 11.2.4.

11.2.1 Sedimentation Basin

A temporary dam or basin at the lowest point of the site has to be constructed for collecting, trapping and storing sediment produced by the construction activities, together with a flow detention facility for reducing peak runoff rates. This would allow most of the sediments to settle before the runoff is directed towards the outfall.

11.2.2 Contour Trenching

Contour trenching is an earth embankment or ridge-and-channel arrangement constructed parallel to the contours along the face of the slope at regular intervals on long and steep slopes (in sloping areas with slopes greater than 10 percent) (see Fig. 2). They are used for reducing runoff velocity, increasing the distance of overland runoff flow, and to hold moisture and minimize sediment loading of surface runoff. Vegetative cover of tree and native grasses in the channels may be planted to stabilize the slopes and reduce erosion.

11.2.3 Mulching

Mulching shall be used with seeding and planting in steep slope areas (slopes greater than 33 percent) that are prone to heavy erosion. Netting or anchoring shall be used to hold it in place. Other surface runoff control measures like contour terracing to break up concentrated flows shall be installed prior to seeding and mulching. Materials such as straw, grass, grass hay and compost shall be placed on or incorporated into

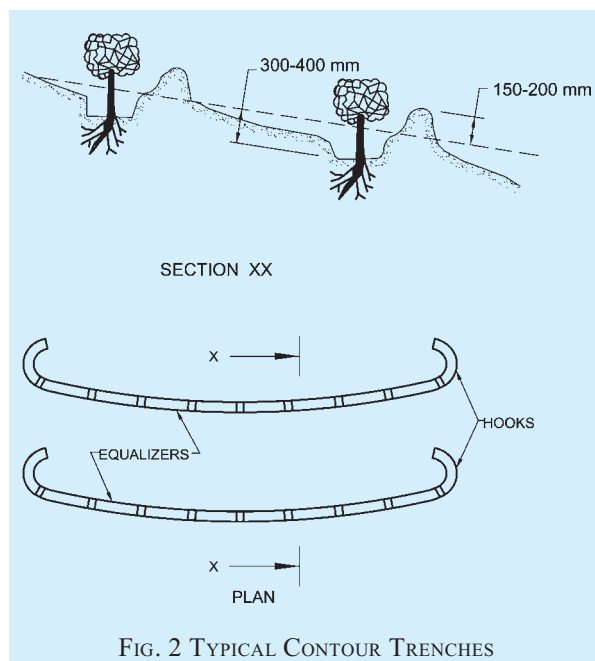

FIG. 2 TYPICAL CONTOUR TRENCHES

the soil surface. In addition to stabilizing soils, mulching will reduce the stormwater runoff over an area. Together with seeding or planting, mulching aids plant growth by holding the seed, fertilizers and topsoil in place. It retains moisture and insulates the soil against extreme temperatures.

11.2.4 Geo-Grids

A deformed or non-deformed netlike polymeric material used with foundation, soil, rock, earth or any other geo-technical engineering-related material as an integral part of the human made project structure or system, called geo-grids may be used as control measure. On filling with lightly compacted soil or fine aggregate, a monolithic structure is created providing an effective means of confinement for unconsolidated materials within the cells and preventing their movement even on steep slopes. If required the area can then be seeded to maintain 'green' environment. The junctions have a central opening through which water can permeate ensuring that organic material receives moisture for rapid growth.

12 SOIL AND WATER CONSERVATION

The soil conservation, sediment control and stormwater management practices as given under 12.1 to 12.3 shall be followed after construction is completed.

12.1 Vegetative Measures

The vegetative measures shall include the following.

12.1.1 Topsoil Laying

This includes the placement of topsoil or other suitable plant material over disturbed lands to provide suitable soil medium for vegetative growth. Topsoil laying shall involve replacing fertile topsoil that were stripped and stockpiled during earlier site development activities; the laid soil shall be stabilized before the next monsoon by planting grass, shrubs and trees.

The following guidelines shall apply to the placement of topsoil:

- a) Existing or established grade of subsoil should be maintained.
- b) A pH of 6.0 to 7.5 and organic content of not less than 1.5 percent by mass is recommended for topsoil. Where pH is less than 6.0, lime shall be applied to adjust pH to 6.5 or higher up to 7.5. Any soils having soluble salt content greater than 500 parts per million shall not be used.
- c) Prior to spreading the topsoil, the sub-grade shall be loosened to a depth of 50 mm to permit bonding. Topsoil shall be spread uniformly at a minimum compacted depth of

on grade of 1:3 or steeper slopes; a minimum depth of 100 mm on shallower slopes is essential. A depth of 300 mm is preferred on relatively flatter land.

12.1.2 Planting/Vegetation Cover

The most effective way to prevent soil erosion, sedimentation and to stabilize disturbed and undisturbed land is through the provision of vegetative cover by effective planting practices. The foliage and roots of plants provide dust control and a reduction in erosion potential by increasing the infiltration, trapping sediment, stabilizing soil, and dissipating the energy of hard rain. Temporary seeding shall be used in areas disturbed after rough grading to provide soil protection until final cover is established. Permanent seeding/ planting is used in buffer areas, vegetated swales and steep slopes. The vegetative cover also increases the percolation of rainwater thereby increasing the ground water recharge.

12.2 Stormwater Management and Filtration Techniques

The surface water flow is increased in urban areas due to predominance of hard surfaces. Stormwater management techniques assure conservation of water thereby increasing the ground water recharge. Filters facilitate draining pollutants out from surface water runoff through straining before discharge into the drainage way. Rain water harvesting and sillage recycle systems need to be implemented on all new constructions over 1 000 m² in urban areas. *See also* Part 9 'Plumbing Services, Section 2 Drainage and Sanitation' and 7.2 of Part 11 'Approach to Sustainability' of the Code.

12.2.1 Rain Water Harvesting Structures in Urban Environment

12.2.1.1 Water harvesting refers to the collection and storage of rainwater and also harvesting surface and ground water, prevention of loss through evaporation and seepage, and other hydrological and engineering interventions aimed at conserving water.

12.2.1.2 The advantages of using rain water harvesting structures in urban areas are as follows:

- a) Water harvesting recharges ground water and is an ideal solution to water problems in areas with inadequate water resources.
- b) Increase in ground water aquifer level due to methods enhancing infiltration.
- c) Mitigation of the effect of drought.
- d) Reduction of stormwater runoff into the public drainage system.
- e) Reduction of flooding of the roads during monsoons.

- f) Removal of pollutants and soil from the stormwater runoff.
- g) Reduction of soil erosion.

12.2.1.3 Methods of ground water recharge may be as follows:

- a) Recharge pits.
- b) Recharge trenches.
- c) Reuse of abandoned dug wells.
- d) Reuse of abandoned hand pumps.
- e) Recharge shafts.
- f) Lateral shafts with bore wells.
- g) Spreading techniques like percolation ponds, check dams or gabion structures.

12.2.2 Structures for Rain Water Harvesting and Soil and Water Conservation

These may be as given in **12.2.2.1** and **12.2.2.2**.

12.2.2.1 Infiltration techniques

- a) *Infiltration trenches* — An infiltration trench is a rock filled trench that receives stormwater runoff. Stormwater passes through a combination of pre-treatment measures, a grass swale and into the trench to be stored in void spaces and then infiltrates into the soil matrix.
- b) *Bio-filtration swale/grass swale* — Bio-filtration swales are vegetated channels with a slope similar to that of standard storm drain channels (less than 0.6 percent), but wider and shallower to maximize flow residence time and promote pollutant removal by filtration through the use of properly selected vegetation. It has to be designed to trap particulate pollutants (suspended solids and trace metals), promote infiltration and reduce the flow velocity of the stormwater runoff. It shall be integrated with stormwater system (see Fig. 3).
- c) *Sand filter* — Sand filters are devices that filter stormwater runoff through a sand layer into an underground drain system which conveys the water to a detention facility. They are effective in removing total suspended solids. The effectiveness of sand filtration is improved if it is preceded by a grass swale with infiltration trench.

12.2.2.2 Detention facilities

- a) *Wet ponds* — Wet ponds are constructed basins that have a permanent pool of water throughout the year (or at least throughout the wet season). Wet ponds retain the stormwater

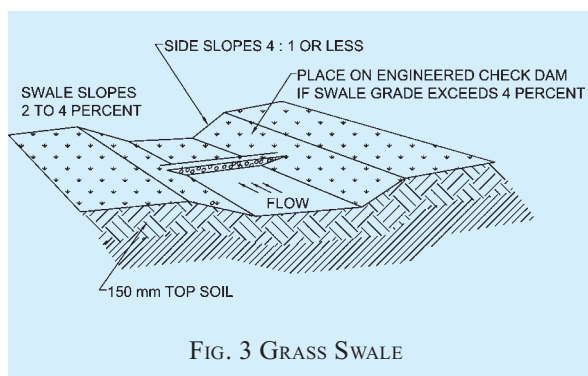

runoff in a permanent pool and facilitate pollution removal through settling and biological update.

- b) *Stormwater wet lands* — Stormwater wet lands are structures similar to wet ponds that incorporate wetland plants into the design. They have to be designed for treating stormwater runoff, and typically have less biodiversity than natural wetland systems. A distinction should be made between using a constructed wet land for stormwater management and diverting stormwater into natural wetland. The latter is not recommended because it would degrade the resource.
- c) *Wet vaults and storage tanks* — Wet vaults and tanks are underground facilities used for the storage of surface water, and typically constructed from reinforced cement concrete (vaults) or corrugated pipes (tanks). The water that is captured in these vaults and tanks may be used later for irrigation.

12.3 Conservation and Reuse of Water for Irrigation

The following measures shall be followed for design of irrigation systems for landscape works:

- a) Water conserving irrigation systems should differentiate between systems for different water use zones on the site. Supplementary irrigation sources should be used by means of appropriate water harvesting measures.
- b) The irrigation system should be designed considering the prevailing wind direction, slope and proposed grade, type of soil, soil percolation, and the type of vegetation to be watered.
- c) Spray irrigation to be designed to provide total head to head cover to avoid dry spots and spray on to paved areas and unplanted surfaces.

- d) Spray irrigation is to be avoided in areas of width less than 3.00 m.
- e) Sullage recycle systems are ideal for large housing complexes and residential colonies. Sullage (or water from kitchens and bathrooms) is treated and recycled for gardening and toilet flushing reducing fresh water requirement by 60 percent. Irrigation system should be designed keeping sullage recycle in view.
- f) For requirements regarding, the volume of water for different kinds of landscapes, Part 9 'Plumbing Services, Section 1 Water Supply' of the Code may be referred.

13 STREET FURNITURE

The design elements for outdoor spaces may be classified under the following categories:

- a) *Pavement and other pedestrian movement spaces, covering*
 - 1) Footpath with heavy pedestrian traffic,
 - 2) Footpath with light pedestrian traffic,
 - 3) Plaza and public assembly spaces,
 - 4) Kerb to footpath, and
 - 5) Steps and ramps.
- b) *Parking and vehicular movement corridor, covering*
 - 1) Parking unit,
 - 2) Median and road divider,
 - 3) Road marking, and
 - 4) Speed breaker.
- c) *Traffic management units, covering*
 - 1) Bollards,
 - 2) Barriers,
 - 3) Crash guard,
 - 4) Gate/Access control,
 - 5) Vehicular height restrictors, and
 - 6) Traffic separators.
- d) *Outdoor public conveniences, covering*
 - 1) Seating,
 - 2) Drinking fountains, and
 - 3) Toilet/Wash rooms.
- e) *Shelter and kiosks, covering*
 - 1) Bus shelters,
 - 2) Police booth,
 - 3) Telephone booth,
 - 4) Milk booth/food stall,
 - 5) Florist,
 - 6) Information desk, and
 - 7) Snack and coffee stall.
- f) *Outdoor illumination, covering*
 - 1) Street light,
 - 2) Façade light, and
 - 3) Ambient light.
- g) *Tree protection units, covering*
 - 1) Tree guard,
 - 2) Tree grate, and
 - 3) Planter.
- h) *Garbage collection units, covering*
 - 1) Litter bin, and
 - 2) Spittoons.
- j) *Service utilities, relating to*
 - 1) Water supply network,
 - 2) Stormwater network,
 - 3) Sewerage network,
 - 4) Electrical network,
 - 5) Telephone lines,
 - 6) Cable e-net,
 - 7) Gas, and
 - 8) Irrigation network.
- k) *Display and signage* — Location of the street furniture shall be coordinated with the traffic flow pattern of vehicles and pedestrians and external services.

NATIONAL BUILDING CODE OF INDIA

PART 10 LANDSCAPE DEVELOPMENT, SIGNS AND OUTDOOR DISPLAY STRUCTURES

Section 2 Signs and Outdoor Display Structures

BUREAU OF INDIAN STANDARDS

CONTENTS

FOREWORD	... 3
1 SCOPE	... 5
2 TERMINOLOGY	... 5
3 PERMITS	... 7
4 MAINTENANCE AND INSPECTION	... 11
5 TYPES OF SIGNS	... 11
6 GENERAL REQUIREMENTS FOR ALL SIGNS	... 11
7 ELECTRIC SIGNS AND ILLUMINATED SIGNS	... 18
8 GROUND SIGNS	... 19
9 ROOF SIGNS	... 19
10 <i>VERANDAH</i> SIGNS	... 19
11 WALL SIGNS	... 20
12 PROJECTING SIGNS	... 20
13 MARQUEE SIGNS	... 21
14 SKY SIGNS	... 21
15 TEMPORARY ADVERTISING SIGNS, TRAVELLING CIRCUS SIGNS, FAIR SIGNS AND DECORATIONS DURING PUBLIC REJOICING	... 21
16 ADDITIONAL GUIDELINES FOR SIGNS IN URBAN AND RURAL AREAS	... 22
17 ENVIRONMENTAL GRAPHICS FOR CITYSCAPE	... 23
ANNEX A SPECIMEN FORM FOR APPLICATION FOR PERMIT TO ERECT, RE-ERECT OR ALTER ADVERTISING SIGN	... 24
LIST OF STANDARDS	... 24

FOREWORD

This Code (Part 10/Section 2) covers the requirements of signs and outdoor display structures with regard to public safety, structural safety and fire safety. With the growing industrialization followed by urbanization of large number of cities and towns, the advertising signs and their appurtenant structures had increased. In the absence of any definite rules, the display of advertising signs had proceeded unrestrained, resulting in a city or town littered indiscriminately with hoardings and advertising signs of all types. Consideration of the aspects of urban aesthetics and public safety, pointed to the necessity for building regulations for the control of advertising signs and structures.

This Section was, therefore, first published in 1970 as Part 10 of the Code and was subsequently revised in 1983 and 2005. In the first revision, comments and suggestions received during its use were incorporated. In the second revision of 2005, the scope of Part 10 was enlarged to cover landscaping along with signs and outdoor display structures. The Part 10 was brought out in two sections, namely, Section 1 Landscape planning and design, and Section 2 Signs and outdoor display structures. In the last revision of this Section, few terminologies related to signs; few explanatory figures; guidelines for signs in urban and rural areas; and guidelines for environmental graphics for the cityscape were introduced.

Based on the experience gained in the use of this Section, the provisions have been modified in this revision. Also certain terminologies have been included. Further, this Section has been linked with Part 3 'Development Control Rules and General Building Requirements' of the Code through reference to the same, for ensuring appropriate controls of signs as applicable for the purpose of accessibility for persons with disabilities.

The provisions of this Section are without prejudice to the regulations already in vogue in areas requiring special controls in harmony with their historical monuments/environment.

For signs coming on highways, relevant IRC rules shall apply. In this connection reference may be made to the following:

IRC 46 : 1972	A policy on road advertisements
IRC 67 : 2012	Code of practice for road signs (<i>third revision</i>)
IRC SP 85 : 2010	Guidelines for variable message signs

For the purpose of deciding whether a particular requirement of this Section is complied with, the final value, observed or calculated, expressing the result of a test or analysis, shall be rounded off in accordance with IS 2 : 1960 'Rules for rounding off numerical values (*revised*)'. The number of significant places retained in the rounded off value should be the same as that of the specified value in this Section.

NATIONAL BUILDING CODE OF INDIA

PART 10 LANDSCAPE DEVELOPMENT, SIGNS AND OUTDOOR DISPLAY STRUCTURES

Section 2 Signs and Outdoor Display Structures

1 SCOPE

1.1 This Code (Part 10/Section 2) covers the requirements with regard to public safety, structural safety and fire safety of all signs and outdoor display structures.

1.2 The requirements for signs and related aspects for the persons with disabilities shall be complied with in accordance with 13 of Part 3 'Development Control Rules and General Building Requirements' of the Code.

2 TERMINOLOGY

For the purpose of this Section, the following definitions shall apply.

2.1 Signs

2.1.1 Abandoned Sign — A sign structure that has ceased to be used, and the owner intends no longer to use the same, for the display of sign copy, or as otherwise defined by state law.

2.1.2 Advertising Sign — Any surface or structure with characters, letters or illustrations applied thereto and displayed in any manner whatsoever out of doors, for purposes of advertising or to give information regarding or to attract the public to any place, person, public performance, article or merchandise whatsoever, and which surface or structure is attached to, forms part of or is connected with any building, or is fixed to a tree or to the ground or to any pole, screen, fence or hoarding or displayed in space.

2.1.3 Animated Sign — A sign employing actual motion or the illusion of motion. Animated signs, which are differentiated from changeable signs (*see 2.1.7*), include the following types:

- a) Electrically activated (flashing/patterned illusionary movement);
- b) Environmentally activated; and
- c) Mechanically activated.

2.1.4 Banner — A flexible substrate on which copy or graphics may be displayed.

2.1.5 Banner Sign — A sign utilizing a banner as its display surface.

2.1.6 Canopy Sign — A sign affixed to the visible surface(s) of an attached or freestanding canopy.

2.1.7 Changeable Sign — A sign with the capability of content change by means of manual or remote input,

including signs which are electrically activated and manually activated

2.1.8 Closed Sign — An advertising sign in which at least more than fifty percent of the area is solid or tightly enclosed or covered.

2.1.9 Combination Sign — A sign that is supported partly by a pole and partly by a building structure.

2.1.10 Direction Sign — A sign which is usually included with an arrow and used for indicating a change in route or confirmation to a correct direction.

2.1.11 Electric Sign — An advertising sign in which electric fittings, which are an integral part of the signs, are used.

2.1.12 Exterior Sign — Any sign placed outside a building.

2.1.13 Freestanding Sign — A sign principally supported by a structure affixed to the ground, and not supported by a building, including signs supported by one or more columns, poles or braces placed in or upon the ground.

2.1.14 Ground Sign — An advertising sign detached from a building, and erected or painted on the ground or on any pole, screen, fence or hoarding and visible to the public.

2.1.15 Identification Sign — A sign that gives specific location information, identifies specific items, for example, 'Parking Lot B', 'Building No. 5', 'First Aid', etc.

2.1.16 Illuminated Sign — An advertising sign, permanent or otherwise, the functioning of which depends upon its being illuminated by direct or indirect light, and other than an electric sign.

2.1.17 Informational Sign — A sign used for overall information for general organization of a series of elements, such as campus plan, bus route, building layout and shopping mall plan.

2.1.18 International Symbol of Accessibility — The symbol consisting of a square overlaid with a stylized image of a person using a wheelchair. It is also known as the (international) wheelchair symbol.

NOTE — The symbol is often provided where access has been improved, particularly for wheelchair users and other mobility impaired persons. The symbol denotes a barrier free environment to help older people, parents with prams and travellers with luggage besides persons with disabilities. The wheelchair symbol is always facing to the right.

2.1.19 Mansard — An inclined decorative roof-like projection that is attached to an exterior building façade.

2.1.20 Marquee Sign — An advertising sign attached to or hung from a marquee canopy or other covered structure projecting from and supported by the building and extending beyond the building wall, building line.

2.1.21 Open Sign — An advertising sign in which at least fifty percent of the enclosed area is uncovered or open to the transmission of wind.

2.1.22 Parapet — A low wall or railing built along the edge of a roof or floor.

2.1.23 Portable Sign — Any sign not permanently attached to the ground or to a building or building surface.

2.1.24 Projecting Sign — An advertising sign affixed to any building element and projecting more than 300 mm therefrom.

2.1.25 Regulatory Sign — Sign that gives operational requirements, restrictions or gives warnings, usually used for traffic delineation or control, for example ‘Stop’, ‘No Parking’, ‘One Way’, etc.

2.1.26 Roof Sign — An advertising sign erected or placed on or above the parapet or any portion of a roof of a building including signs painted on the roof of a building.

2.1.27 Sky Sign — An advertising sign displayed in space like,

- a) a gas filled balloon anchored to a point on the ground and afloat in the air with or without a streamer of cloth, etc; or
- b) sky-writing, that is, a sign or word traced in the atmosphere by smoke discharged from an aeroplane.

2.1.28 Sign — Any device visible from a public place that displays either commercial or non-commercial messages by means of graphic presentation of alphabetic or pictorial symbols or representations. Non-commercial flags or any flags displayed from flagpoles or staffs shall not be considered as signs.

2.1.29 Sign Area — The area of the smallest geometric figure, or the sum of the combination of regular geometric figures, which comprise the sign face. The area of any double-sided or ‘V’ shaped sign shall be the area of the largest single face only. The area of a sphere shall be computed as the area of a circle. The area of all other multiple-sided signs shall be computed as 50 percent of the sum of the area of all faces of the sign.

2.1.30 Sign Copy — Those letters, numerals, figures, symbols, logos and graphic elements comprising the

content or message of a sign, exclusive of numerals identifying a street address only.

2.1.31 Sign Face — The surface upon, against or through which the sign copy is displayed or illustrated, not including structural supports, architectural features of a building or sign structure, nonstructural or decorative trim, or any areas that are separated from the background surface upon which the sign copy is displayed by a distinct delineation, such as a reveal or border.

2.1.32 Sign Structure — Any structure supporting a sign.

2.1.33 Temporary Sign — An advertising sign, banner or other advertising device constructed of cloth, canvas, fabric or any other light material, with or without a structural frame, intended for a limited period of display; including decorative displays for holidays or public demonstrations.

2.1.34 Verandah Sign — An advertising sign attached to, posted on or hung from a *Verandah*.

2.1.35 Wall Sign — An advertising sign, other than a projecting sign, which is directly attached to or painted or pasted on the exterior surface of or structural element of any building.

2.1.36 Window Sign — A sign affixed to the surface of a window with its message intended to be visible to and readable from the public way or from adjacent property.

2.2 General

2.2.1 Approved — Approved by the Authority having jurisdiction.

2.2.2 Area of Special Control — Any area declared an area of special control by the Authority in respect of the display of advertising signs, where the requirements for such display are more restrictive than elsewhere in the area controlled by the Authority.

2.2.3 Authority Having Jurisdiction — The authority which has been created by a statute and which for the purpose of administering the Code/Part, may authorize a committee or an official to act on its behalf; hereinafter called the ‘Authority’.

2.2.4 Building Line — The line up to which the plinth of a building adjoining a street or an extension of a street or on a future street may lawfully extend. It includes the lines prescribed, if any, in any scheme.

2.2.5 Combustible Material — A material is combustible, if it burns or adds heat to a fire when tested for non-combustibility in accordance with good practice [10-2(1)].

2.2.6 Owner — A person, a group of persons or a body having a legal interest in land and/or building thereon. This includes freeholders, leaseholders or those holding a sub-lease, who will have legal right to occupation and have liabilities in respect of safety or building condition.

In the case of lease or sub-lease holders, as far as ownership with respect to the structure is concerned, the structure of a flat or structure on a plot belongs to the allottee/lessee till the allotment/lease subsists.

NOTE—For the purpose of the Code, the word ‘owner’ will also cover the generally understood terms like ‘client’, ‘user’, etc.

2.2.7 Street Line — The line defining the side limits of a street.

3 PERMITS

3.1 Application

3.1.1 Conditions for Grant of Permit

No sign shall be erected, altered or maintained without first obtaining a permit for the same from the Authority and shall be subjected to the following conditions:

- a) Written permission shall not be granted or renewed at any one time, for a period exceeding three years from the date of grant of such permission or renewal.
- b) Written permission or the renewal granted by the Authority shall become void,
 - 1) if any sign or the part thereof falls either through an accident or any other causes;
 - 2) if any addition is made except for the purpose of making it secure under the direction of the Authority;
 - 3) if any change is made in the sign or part thereof;
 - 4) if any addition or alternation is made to the building or structure upon or over which the sign is erected and if such addition or alteration involves disturbance of the sign or any part thereof; or
 - 5) if the building or structure upon or over which the sign is erected fixed or restrained becomes demolished or destroyed.
- c) Light and ventilation of buildings, if any, situated near the signs and hoardings, shall not be obstructed in any way;
- d) Advertisements displayed shall not be of any objectionable or obscene nature given under 3.3;
- e) In the public interest, the Authority shall have the right to suspend the licence even before the expiry period, upon which the licensee shall remove the signs;

- f) Licensee shall be responsible for the observance of all the rules and regulations laid down by the Authority;
- g) Signs should not mar the aesthetic beauty of the locality;
- h) Signs, other than those pertaining to building, shall not be permitted to come in front of buildings such as hospitals, educational institutions, public offices, museums, buildings devoted to religious worship and buildings of national importance;
- j) Maintenance and inspection of advertising signs and their supports shall be as given under 4.
- k) No hoarding sign on the highways shall be put without the permission of the Authority maintaining/in-charge of flyovers, highways/ roads; and
- m) In addition all signs shall conform to the general requirements given under 6.
- n) Signs shall not be nailed or tied to trees or any other woody vegetation.

3.1.2 Application for Licence or Permit and Required Drawings

Every person intending to erect, alter or display an advertising sign for which a permit or licence is required, shall make application to the Authority on the prescribed form containing such particulars as the Authority may require. Such form (*see Annex A*) shall be signed by the applicant and by the owner of the site upon which such sign is or is to be situated and shall include the following information:

- a) Full specifications showing the length, height and weight of the sign, the location where it is to be erected, the manufacturer’s name and address and where applicable, the number of lights and electrical details of the same.
- b) Such form shall be accompanied by a location plan indicating the position of the sign on the site drawn to a scale of 1:500 and by full detail drawing drawn to a scale of 1:20 or an exact multiple thereof in ink or on prints including, if required by the Authority, an elevation showing the sign in relation to the façade.
- c) In the case of roof signs, projecting signs or ground signs in addition to the foregoing, the size of all members of supporting frameworks and anchorages, and, if required by the Authority, the necessary design calculations shall be furnished with the application.
- d) Any other particulars as may be desired by the Authority as covered in 6.

- e) In the case of sky signs, necessary information as desired by the Authority may be supplied.

3.1.3 The Authority may, on the receipt of an application for permit, either sanction or refuse such a permit or sanction with modifications as deemed necessary and shall communicate decision to the applicant. If within 30 days of receiving an application for a permit the Authority fails to intimate in writing to the applicant, the permit along with the plans shall be deemed as sanctioned.

3.1.4 When a sign has to be altered, information only on such plans and statements, as may be necessary, shall be included in the form. However, the changing of movable parts of an approved sign that is designed for such changes, shall not be deemed an alteration provided the conditions of the original approval and the requirements of this part are not violated.

3.1.5 Existing Advertising Signs

Advertising signs in existence at the date of promulgation of the Code and covered by a valid licence or permit issued by the Authority shall not require to be licensed under the Code until such licence or permit has expired, provided it is maintained in a good and safe condition.

3.1.6 For advertising signs, application shall be submitted through a structural engineer along with necessary drawings and structural calculations. The wind load taken in the design calculations shall be in accordance with Part 6 ‘Structural Design, Section 1 Loads, Forces and Effects’ of the Code.

3.2 Exemptions

3.2.1 No permit shall be required for signs and outdoor display structures of the following types:

- a) If the signs are exhibited within the window of any building provided it does not affect light and ventilation of the building.
- b) If it relates to the trade or business carried on within the land or building upon which such advertisement is exhibited or to any sale, entertainment or meeting or lettering of such land or building or any effects therein; or to the trade or business carried on by the owner of any tramcar, omnibus or other vehicle upon which such advertisements is exhibited, provided it is not more than 1.2 m².
- c) In addition no permission shall be required for the signs covered by the provisions 3.2.2 to 3.2.5. Such exemptions, however shall not construed to relieve the owner of the sign from the responsibility of erection and maintenance in compliance with the Code.

3.2.2 Wall Signs

The wall signs listed in 3.2.2.1 to 3.2.2.3 shall not require a permit.

3.2.2.1 Store signs

Non-illuminated signs erected over a show window or over the door of a store or business establishment which announce the name of the proprietor and the nature of the business conducted therein; the sign shall not be more than 1 m in height and the width of the business establishment.

3.2.2.2 Government building signs

Signs erected on a municipal, state or central government building which announce the name, nature of the occupancy and information.

3.2.2.3 Name plates

Any wall sign erected on a building or structure indicating the name of the occupant of building, which is not more than 0.5 m² in area.

3.2.3 Ground Signs

3.2.3.1 Transit directions

The erection or maintenance of a sign designating the location of a transit line, a rail track, station or other public carrier when not more than 0.5 m² in area.

3.2.3.2 Highway signs

In general, advertisements of the following classes are permissible without permission though these should reasonably conform to the principles set out in 3.5.1:

- a) *Class (1) Functional Advertisements*
 - 1) Official warning signs, traffic directions, sign posting and notices or advertisements posted or displayed by or under the directions of any public or court officer in the performance of his official or directed duties.

Example:

DIVERSION AHEAD

- 2) Direction signs to places of public amenity, such as petrol filling stations, hospitals, first-aid posts, police stations and fire stations.

Examples:

HOSPITAL

BUS STATION

- 3) Signs relating solely to any city, town, village or historic place, shrine, place of tourist interest.

Examples:

ELLORA
CAVES

FARIDABAD
TOWN

- 4) Signs, notices, etc, erected by the Defence Department for information of members of the armed forces or the public.

Example:

ARTILLERY RANGE AHEAD

- 5) Signs restricting trespass of property, limited to 0.2 m² in area or less.

Examples:

PRIVATE PROPERTY

TRESPASSERS WILL BE PROSECUTED

- 6) Signs or notices, 0.2 m² in area or less, placed so as to show direction to a residence and planted sufficiently away from the carriageway.

b) *Class (2) Advertisements Relating to the Premises on which these are Displayed*

- 1) Advertisements for the purpose of identification, direction or warning with respect to the land or building on which they are displayed, provided not exceeding 0.2 m² in area in the case of any such advertisement.

Examples:

MIND THE STEP

PROPERTY OF MOHAN LAL & CO

USHA KIRAN

- 2) Advertisements relating to any person, partnership or company separately carrying on a profession, business trade at the premises where any such advertisement is displayed; limited to one advertisement not exceeding 0.3 m² in area in respect of each such person, partnership or company.

Example:

RAM LAL & COMPANY

- 3) Advertisements relating to any institution of a religious, educational, cultural, recreational, medical or similar character or any hotel, public house, DAK bungalow, block of flats, club, boarding house or hostel situated on the land on which any such advertisement is displayed; limited to one advertisement not exceeding 1.2 m² in area in respect of each such person, partnership or company.

Examples:

COLLEGE OF ENGINEERING

HOLIDAY HOUSE

ROTARY CLUB

c) *Class (3) Advertisements of Temporary Nature*

- 1) Advertisements relating to the sale or letting of the land on which they are displayed; limited in respect of each such sale or letting to one advertisement not exceeding 2 m² in area.

Examples:

TO LET

HOUSE FOR SALE

- 2) Advertisements announcing sale of goods or livestock, and displayed on the land where such goods or livestock are situated or where such sale is held, limited to one advertisement not exceeding 1.2 m² in area.

Examples:

SALE THIS WEEK

CATTLE SALE

- 3) Advertisements relating to the carrying out of building or similar work on the land on which they displayed exceeding 2 m² in area.

Example:

CAUTION EXCAVATION IN PROGRESS

- 4) Advertisements announcing any local event of a religious, educational, cultural, political, social or recreational character, not being an activity promoted or carried on for commercial purposes; limited to a display of advertisements occupying an area not exceeding 0.6 m² on any premises.

Examples:

DIWALI MELA

FLOWER SHOW

3.2.4 *Temporary Signs*

3.2.4.1 *Construction site signs*

Construction signs, engineers' and architects' signs and other similar signs which may be authorized by the Authority in connection with construction operations (see Table 1).

3.2.4.2 *Special displays signs*

Special decorative displays used for holidays, public demonstrations or promotion of civic welfare or charitable purposes, on which there is no commercial advertising, provided that the Authority is not held responsible for any resulting damage (*see 15.2.2*).

3.2.5 The qualitative requirements of signs given in Table 1 shall not require any permit.

3.3 **Unsafe and Unlawful Signs**

3.3.1 *Notice of Unsafe and Unlawful Signs*

When any sign becomes insecure, or in danger of falling, or otherwise unsafe, or if any sign shall be unlawfully installed, erected or maintained in violation of any of the provisions of the Code, the owner thereof, or the person or firm maintaining the same, shall upon written notice of the Authority, forthwith in the case of immediate danger and in any case within not more than three days, make such sign conform to the provisions of this Section or shall remove it. If within three days the order is not complied with, the Authority may remove such sign at the expense of the owner.

3.3.1.1 Notwithstanding the above, it shall be the responsibility of the owner to ensure the safety of the advertising signs, even without a reference from the Authority. The owner shall also ensure to remove the remnant structures of the abandoned sign.

3.3.2 Any sign which in the opinion of the Authority is an obscene, repulsive, revolting, or objectionable character; or prejudicial to the Authority; or savouring undesirable political propaganda; or of a nature calculated to produce pernicious or injurious effect on public or any particular class of persons; or is displayed in such a place, in such a manner or by any such means as, in the opinion of the Authority, could be likely to affect injuriously the amenities of, or to disfigure any neighbourhood, shall not be permitted under any circumstances.

3.4 **Area of Special Control**

3.4.1 Whenever in the opinion of the Authority it is likely that any advertising device otherwise permitted in terms of the Code may affect injuriously or disfigure any particular area within the jurisdiction of the Authority it may proclaim such area as an area of special control. Parks and land for public use may also be included as areas of special control.

3.4.2 Subject to the provisions of 3.4.1 within such area, the erection and display of any advertising sign shall be prohibited or restricted in any manner deemed necessary by the Authority. The Authority shall publish its intention of proclaiming such an area in one or more

newspapers circulating in the area of jurisdiction of the Authority. Any owner of property within such area who may feel aggrieved by such proclamation may appeal within one month from such publication against proclamation of such an area to the Authority whose decision shall be final.

3.4.3 The wording on any *Verandah* sign, permitted by the Authority, in any area of special control, shall be restricted to the name of the proprietor or firm occupying the premises, the name of the building or institution, the general business or trade carried on, such as 'JEWELLER', 'CAFÉ', 'DANCING', or information regarding the location of the building entrance, box office or regarding the theatre programme or similar information. No *Verandah* sign in any area of special control shall advertise any particular article of merchandise nor shall any such sign refer to price or reduction in price.

3.4.3.1 Normally no other advertising sign shall, except as for 3.4.3, be within a distance of 30 m from the area of special control.

3.5 **Prohibition of Advertising Signs on Certain Sites**

Where the Authority is of the opinion that any site is unsuitable for display of advertising signs by virtue of the general characteristics of the locality in regard to historic, architectural, cultural or similar interest, or by virtue of its position, the display of such signs is likely to affect in any way the safety of any form of transport, erection of advertising signs on such a site shall be prohibited.

3.5.1 *Highways and Roads*

In general the following advertisements should not be permitted:

- a) At or within 100 m of any road junction, bridge or railway crossing or another crossing. In urban areas, this distance may be reduced to 50 m, provided there is no conflict with the requirements stated further on.

NOTE — The safe stopping distance for a vehicle traveling at a speed of 50 km/h is 60 m. This should be the 'uninfluenced distance' for a driver approaching a junction. Assuming that 3 s is the time during which the influence of an advertisement board persists, the distance travelled in this time will be about 40 m. The sign should, therefore, be more than 100 m away from the junction. Hence 100 m is suggested.

- b) In such manner and at such places as to obstruct or interfere with the visibility of approaching, merging or intersecting traffic;
- c) Within 10 m of the edge of a carriageway;

NOTE — A distance of 10 m may be taken as the normal minimum setback from the edge of the

carriageway, the maximum area of the advertisement being 0.3 m² for every metre of setback.

- d) Within 50 m along the road, of any sign board erected for the regulation of traffic under the orders of a Public Authority, such as a Traffic Authority, a Public Transport Authority, or a Local Authority;
- e) In such a form as will obscure or hinder interpretation of any sign, signal or other device erected for traffic control by the Public Authorities. For instance, the advertisements should not imitate or resemble, in colour or shape, the standard legal traffic signs, or employ such words as 'STOP' in the same manner as used on traffic signs;
- f) On boards, placards, cloth banners or sheets (except traffic signs) hung across a road as they distract the attention of the driver and are, therefore, hazardous;

NOTE — Any advertisement allowed on the sides of a foot over bridge or flyover across the carriageways shall be restricted in size and shape such that no part of the advertisement board projects beyond the top, bottom and sides of the parapet of foot over bridge or flyover.

- g) In such form as will obstruct the path of pedestrians and hinder their visibility at crossings;
- h) Within right-of-way of the road; and
- j) When these will affect local amenity.

3.5.2 Illuminated advertisements of the following description are objectionable from the angle or traffic safety and should not be allowed:

- a) Advertisements which contain, include or are illuminated by any flashing, intermittent or moving light or lights except those giving public service information, such as time, temperature, weather or date;
- b) Illuminated advertisements of such intensity or brilliance as to cause glare or impair vision of the driver or pedestrians, or which otherwise interfere with any operations of driving; and
- c) Advertisements illuminated in such a way as to obscure or diminish effectiveness of any official sign, device or signal.

4 MAINTENANCE AND INSPECTION

4.1 Maintenance

All signs for which a permit is required, together with

all their supports, braces, guys and anchors shall be kept in good repair, both structurally and aesthetically, and when not galvanized or constructed of approved corrosion-resistive non-combustible materials, shall be painted, when necessary to prevent corrosion.

4.2 Housekeeping

It shall be the duty and responsibility of the owner of every sign to maintain the immediate premises occupied by the sign, in a clean, sanitary and healthy condition.

4.3 Inspection

Every sign for which a permit has been issued and every existing sign for which a permit is required shall be inspected by the Authority at least once in every calendar year.

5 TYPES OF SIGNS

In this Section, the following types of signs are covered [*see also* a few explanatory figures of general sign types (*see* Fig. 1A), comparison of roof and wall or fascia sign (*see* Fig. 1B) and sign area computation methodology (*see* Figs. 1C and 1D)].

- a) Electric and illuminated signs (*see* 7);
- b) Ground signs (*see* 8);
- c) Roof signs (*see* 9);
- d) *Verandah* signs (*see* 10);
- e) Wall signs (*see* 11);
- f) Projecting signs (*see* 12);
- g) Marquee signs (*see* 13);
- h) Sky signs (*see* 14); and
- j) Miscellaneous and temporary signs (*see* 15).

6 GENERAL REQUIREMENTS FOR ALL SIGNS

6.1 Loads

Every advertising sign shall be designed so as to withstand safely the wind, dead, seismic and other loads as set out in Part 6 'Structural Design, Section 1 Loads, Forces and Effects' of the Code.

6.2 Illumination

No sign shall be illuminated by other than electrical means, and electrical devices and wiring shall be installed in accordance with the requirements of Part 8 'Building Services, Section 2 Electrical and Allied Installations' of the Code. In no case, shall any open spark or flame be used for display purposes unless specifically approved by the Authority.

Table 1 Advertising Signs for Which No Permit or Licence is Required

(Clause 3.2.5)

SI No.	Class (with Sample)	Area of Each Separate Sign (or Aggregate)	Maximum Height Above Ground Floor Level to Top of Sign	Illumination Provided	Description of Sign		Remarks
					Number Permitted	Maximum Dimension of Letters, Symbols, etc	
(1)	(2)	(3)	(4)	(5)	(6)	(7)	(8)
i)	Functional signs of certain authorities statutory undertakings, public transport undertakings, fire brigades, etc <div style="border: 1px solid black; padding: 2px; display: inline-block; margin: 5px;">BUS STATION</div>	As may be reasonably required for the safe and efficient performance of the function	As stated in col 3	As stated in col 3	As stated in col 3	As stated in col 3	
ii)	Miscellaneous signs relating to premises on which they are displayed: a) Identification, direction, or warning <div style="border: 1px solid black; padding: 2px; display: inline-block; margin: 5px;">X-RAY UNIT</div> <div style="border: 1px solid black; padding: 2px; display: inline-block; margin: 5px;">MIND THE STEP</div>	Not more than 4 m ²	Not more than 5 m (in area of special control 4m)	Only to indicate that medical or similar services or supplies are available on premises where advertisement is displayed ¹⁾	Any number	Not more than 750 mm (in area of special control 300 mm)	
	b) Person partnership or company carrying profession business, or trade; name or private person <div style="border: 1px solid black; padding: 2px; display: inline-block; margin: 5px;">CHAWLA & CO. LTD</div> <div style="border: 1px solid black; padding: 2px; display: inline-block; margin: 5px;">S. BOSE</div>	Not more than 0.3 m ² each	Not more than 5 m (in area of special control 4 m)	Only to indicate that medical or similar services or supplies are available on premises where advertisement is displayed ¹⁾	One at each entrance	Not more than 750 mm (in area of special control 300 mm)	
	c) Relating to any institution of a religious, educational, cultural, or medical character; name of building or premises <div style="border: 1px solid black; padding: 2px; display: inline-block; margin: 5px;">COLLEGE OF COMMERCE</div> <div style="border: 1px solid black; padding: 2px; display: inline-block; margin: 5px;">XYZ FLATS</div>	Not more than 1.2 m ² each	Not more than 5 m (in area of special control 4 m)	Only to indicate that medical or similar services or supplies are available on premises where advertisement is displayed ¹⁾	One on each frontage	Not more than 750 mm (in area of special control 300 mm)	
iii)	Temporary signs (cloth banners): a) Signs relating to the sale or letting off the land (within the site of the building) on which they are displayed <div style="border: 1px solid black; padding: 2px; display: inline-block; margin: 5px;">HOUSE FOR SALE</div>	Not more than 2.4 m ² (ratio of width to depth 2:1) in aggregate area. No sign to project more than 1 m when displayed on a building (within the site)	Not more than 5 m (in area of special control 4 m)	None	Any number but aggregate area not to exceed that given in col 3	Not more than 750 mm (in area of special control 300 mm)	Shall not be displayed earlier than 28 days before the sale or other matter is due to start and shall be removed within 14 days after the conclusion of such sale or matter

PART 10 LANDSCAPE DEVELOPMENT, SIGNS AND OUTDOOR DISPLAY STRUCTURES — SECTION 2 SIGNS AND OUTDOOR DISPLAY STRUCTURES

(1)	(2)	(3)	(4)	(5)	(6)	(7)	(8)	
a)	Signs relating to the carrying out of building or similar operations on the land where sign is displayed	THIS FACTORY IS BEING ERECTED BY XYZ CONSTRUCTION CO Building and Engineering Contractor	Not more than 4 m ²	Not more than 5 m (in area of special control 4 m)	None	One for each road frontage for each contractor or sub-contractor	Not more than 750 mm (in area of special control 300 mm)	May be displayed only while such works are in progress
b)	Signs announcing any local event in connection with an activity promoted for non-commercial purposes by various local organizations	DIWALI MELA	Not more than 1.5 m ² (in aggregate area 4 m ²)	Not more than 5 m (in area of special control 4 m)	None	Any number but aggregate area not to exceed that given in col 3 on any premises	Not more than 750 mm (in area of special control 300 mm)	Shall not be displayed earlier than 28 days before the event is due to start and shall be removed within 14 days of its conclusion
c)	Signs and business premises for areas of special control, signs on business premises with reference to the business, the goods sold, or the services provided, etc, in these premises and the name and qualifications of the person carrying on such activity	XYZQR BANK	Not to exceed one-twelfth of area of each face (up to a height of 4 m)	Not more than 4 m	Only to indicate that medical or similar services or supplies are available where advertisement is displayed ¹⁾	Any number but aggregate area not to exceed that given in col 3	Not more than 300 mm	Area to be computed as if the advertisement were laid flat against the face of the building

¹⁾ Or where connected with danger.

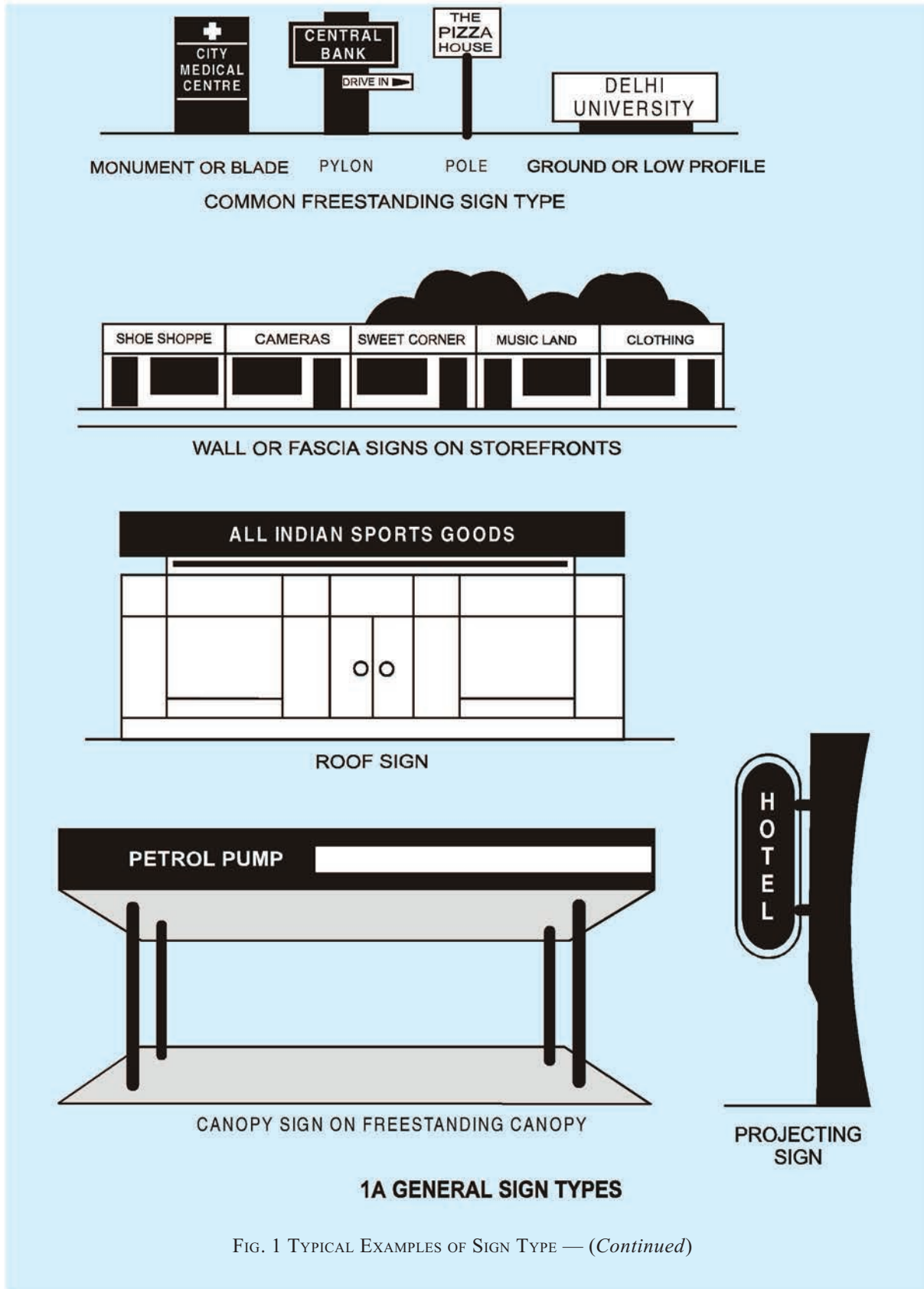

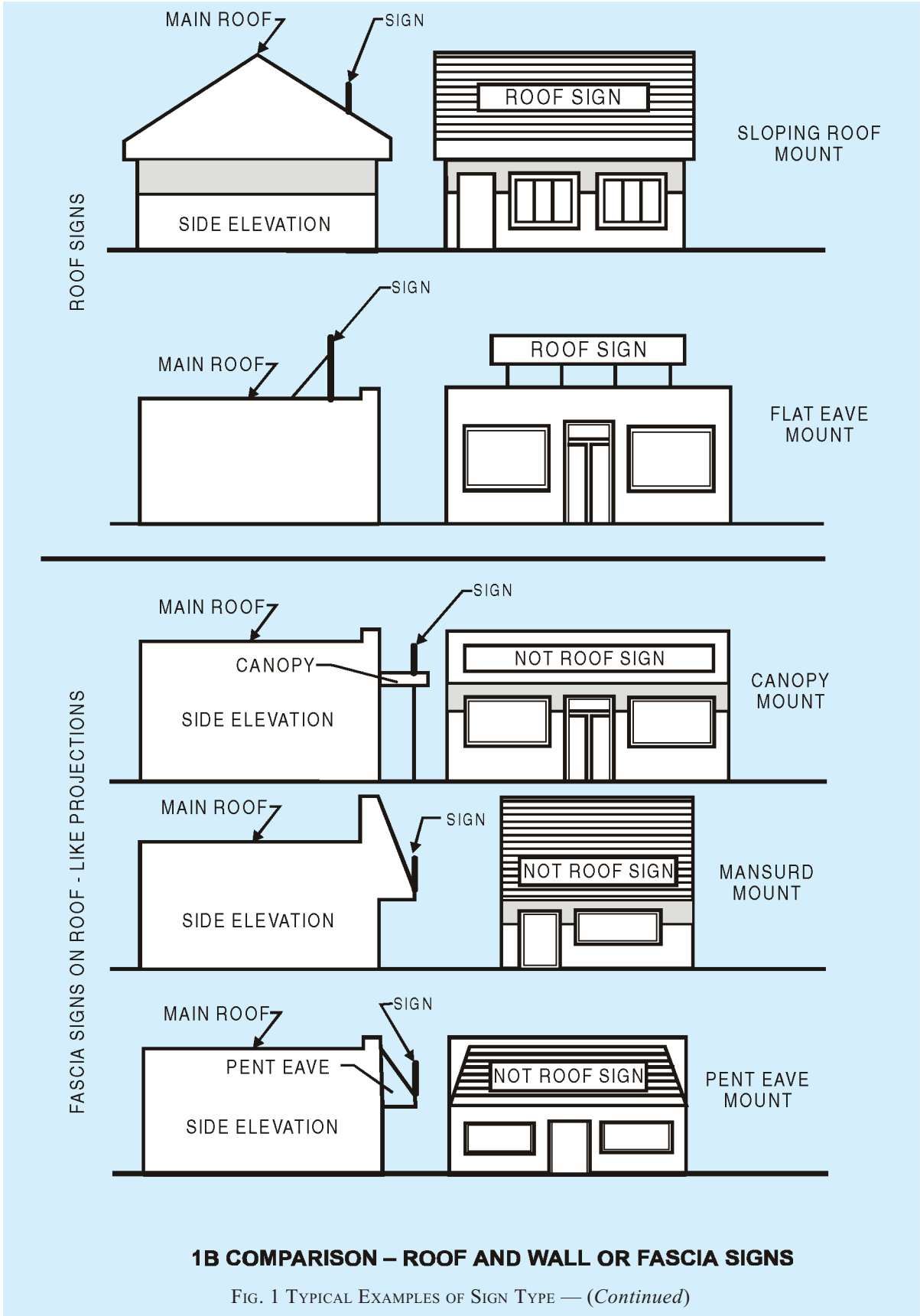

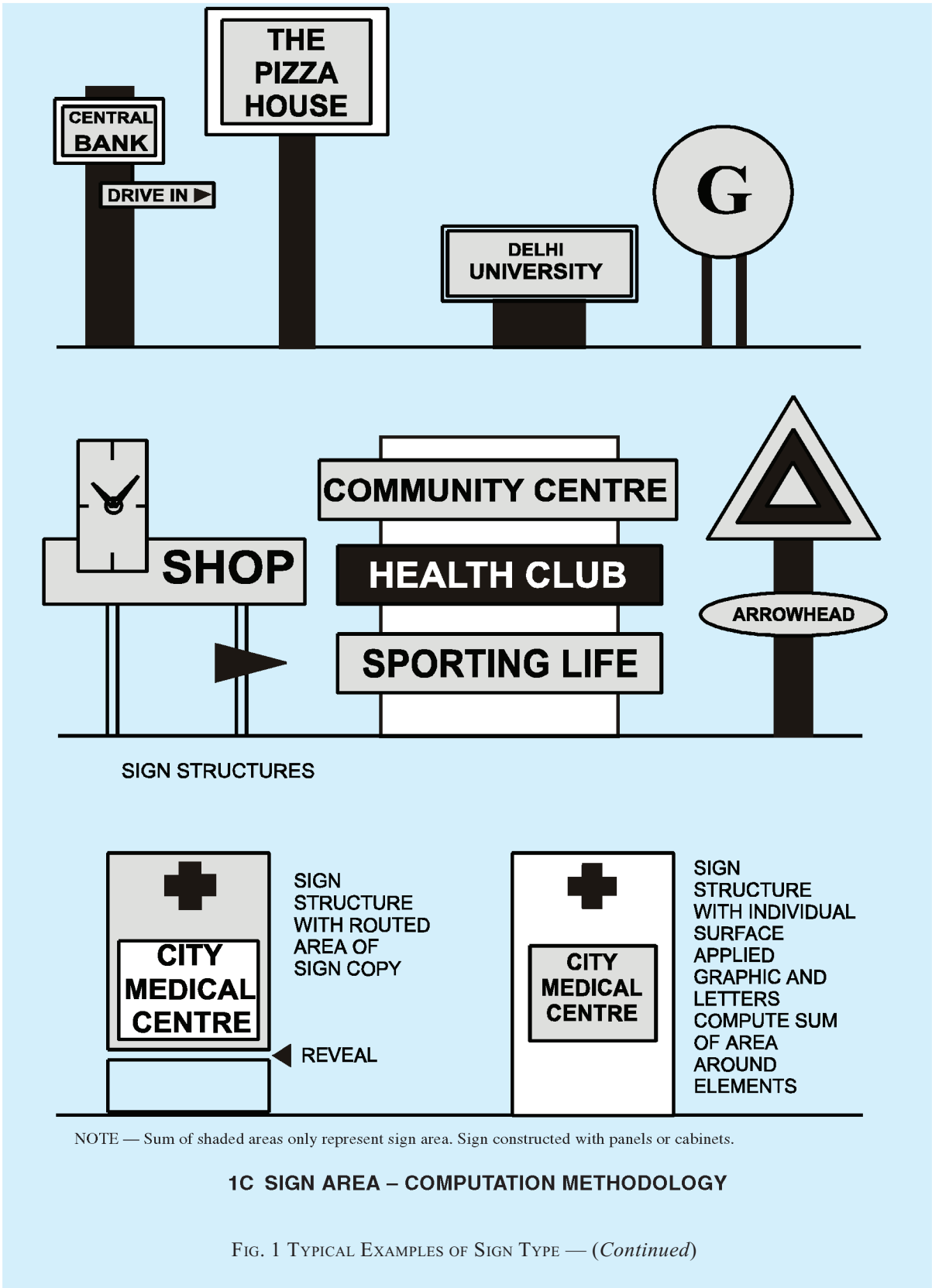

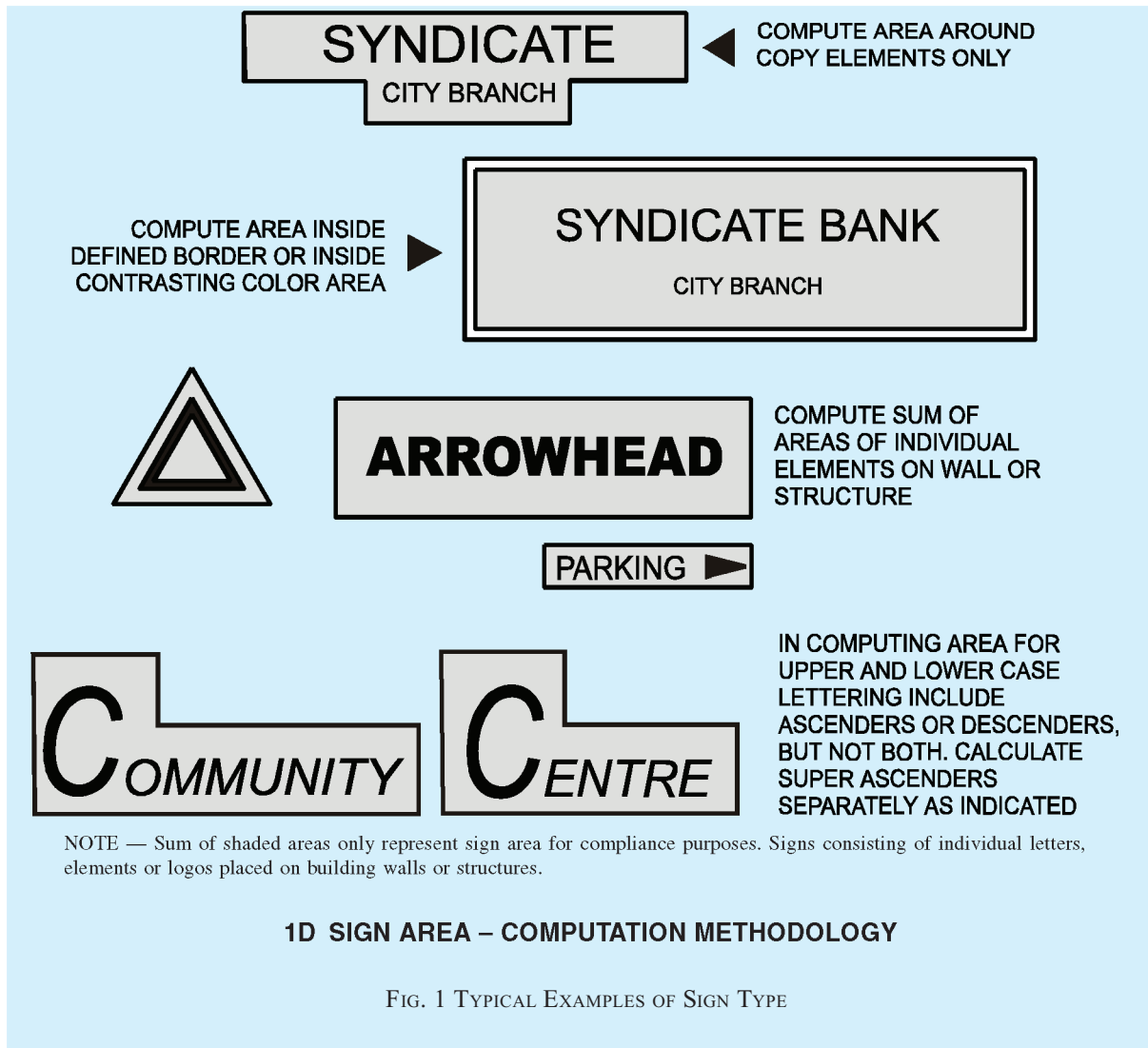

6.3 Design and Location of Advertising Signs

- a) Sign should not obstruct any pedestrian movement, fire escape, door or window, opening used as a means for egress or fire fighting purposes.
- b) No sign shall in any form or manner interfere with openings required for light and ventilation.
- c) When possible, signs should be gathered together into unified systems. Sign clutter should be avoided in the landscape.
- d) Signs should be combined with lighting fixture to reduce unnecessary posts and for ease of illuminating the signs.
- e) Information signs should be placed at natural gathering spots and included in the design of sight furniture.
- f) Placement of sign should be avoided where they may conflict with pedestrian traffic.

- g) Sign should be placed to allow safe pedestrian clearance vertically and latterly.
- h) Braille strips may be placed along sign edges or raised letters may be used for readability for the blind and partially sighted.
- j) No sign shall be attached in anyway to a tree or shrub.

6.4 Use of Combustibles

6.4.1 Ornamental Features

Wood or plastic or other materials of combustible characteristics similar to wood may be used for mouldings, cappings, nailing blocks, letters and latticing where permitted and for other purely ornamental features of signs.

6.4.2 Sign Facings

Sign facings may be made of approved combustible

materials provided the area of each face is not more than 10 m² and the wiring for electric lighting is entirely enclosed in metal conduit and installed with a clearance of not less than 5 cm from the facing material.

6.5 Damage or Defacement by Removal of Advertising Signs

Whenever any advertising sign is removed, whether in consequence of a notice or order under the Code or otherwise, any damage or defacement to the building or site on or from which such sign was displayed, shall be made good to the satisfaction of the Authority.

6.6 Alteration to Ground Level

Whenever any alteration is made to the ground level adjacent to any advertising sign, the owner of the site on which sign is erected, shall be responsible for the alteration of the height of such sign so as to conform to the requirements of this Section.

6.7 Traffic Control Interference

No advertising sign shall be erected or maintained which interferes with or is likely to interfere with any sign or signal for the control of traffic. No advertising sign shall be placed particularly in bends and curves so as to obstruct the view of traffic at intersecting streets.

6.8 Draining of Signs

Adequate provision for drainage shall be made in every advertising sign, where the possibility of collection of moisture exists.

6.9 Glass in Signs

All glass used in advertising signs, other than glass tubing used in gas discharge or similar signs, shall be of safety glass conforming to accepted standards [10-2(2)], at least 3 mm thick. Glass panels in advertising signs shall not exceed 6 m² in area, each panel being securely fixed in the body of the sign independently of all other panels. Glass signs shall be properly protected from the possibility of damage by falling objects by the provisions of suitable protecting metal canopies, or by other approved means. Use of glass may be discouraged or avoided wherever possible for signs placed overhead.

6.10 Interference to Fire Hydrants

Advertising signs shall be so placed as not to obstruct the use of the hydrants or other fire fighting appliances.

6.11 Servicing Devices

Ladders, platforms, hooks, rings and all other devices for the use of servicing personnel shall have safety devices and suitable design loadings (reference may also be made to Part 7 'Construction Management, Practices and Safety' of the Code).

6.12 Animated Devices

Signs which contain moving section or ornaments shall have fail-safe provisions to prevent the section or ornaments from releasing and falling or shifting its center of gravity more than 450 mm. The fail-safe device shall be in addition to the mechanism and its housing which operate the movable section or ornament. The fail-safe device shall be capable of supporting the full dead weight of the section or ornament when moving mechanism releases.

7 ELECTRIC SIGNS AND ILLUMINATED SIGNS

7.1 Material for Electric Signs

Every electric sign shall be constructed of non-combustible material except where the sign is purely a flood-lit sign.

7.2 Installation of Electric Signs and Illuminated Signs

Every electric sign and illuminated sign shall be installed in accordance with Part 8 'Building Services, Section 2 Electrical and Allied Installations' of the Code.

7.3 No illuminated sign in red, amber or green colour shall be erected or maintained within a horizontal distance of 10 m of any illuminated traffic sign.

7.4 All advertising signs illuminated by light other than a white light, at height of less than two storeys or 6 m above the footpath, whichever be the greater height, shall be suitably screened so as to satisfactorily prevent any interference with any sign or signal for the control of traffic.

7.5 Intense Illumination

No person shall erect any sign which is of such intense illumination as to disturb the residents in adjacent or nearby residential buildings. Notwithstanding any permission given for such erection, any such sign which after erection is, in the opinion of the Authority, of such intense illumination as to disturb the occupants of adjacent or nearby buildings shall, on the order of the Authority, be suitably altered or removed by the owner of the site concerned within such reasonable period as the Authority may specify.

7.6 Hours of Operation

No electric sign, other than those necessary in the opinion of the Authority in the interest of public amenity, health and safety, shall be operated between midnight and sunrise.

7.7 Flashing, Occulting and Animated Signs

No flashing, occulting or animated advertising signs, the periodicity of which exceeds 30 flashes to the

minute, shall be erected so that the lowest point of such signs is less than 9 m above the ground level.

7.8 For illuminated signs in the vicinity of airports, the Directorate General of Civil Aviation should be consulted.

8 GROUND SIGNS

8.1 Material

Every ground sign exceeding 6 m in height together with frames, supports and braces shall be constructed of non-combustible material except as in **6.4**.

8.2 Dimensions

No ground sign shall be erected to a height exceeding 9 m above the ground. Lighting reflectors may extend beyond the top or face of the sign.

8.3 Supports and Anchorage

Every ground sign shall be firmly supported and anchored to the ground. Supports and anchors shall be of treated timber in accordance with good practice [10-2(3)], or metal treated for corrosion resistance or masonry or concrete.

8.4 Site Cleaning

The owner of any site on which a ground sign is erected shall be responsible for keeping such part of the site as is visible from the street, clean, sanitary, inoffensive and free of all obnoxious substances and unsightly conditions to the approval of the Authority.

8.5 Obstruction to Traffic

No ground sign shall be erected so as to obstruct free access to or egress from any building.

8.6 Set Back

No ground sign shall be set nearer to the street line than the established building line.

8.7 Bottom Clearance

The bottom line of all ground signs shall be at least 0.6 m above the ground, but the intervening space may be filled with open lattice work or platform decorative trim.

8.8 Ground painted signs shall conform to the requirements of **6** and **7**, where applicable.

9 ROOF SIGNS

9.1 Material

Every roof sign together with its frames, supports and braces, shall be constructed of non-combustible material, except as in **6.4**. Provision shall be made for electric grounding of all metallic parts; and where

combustible materials are permitted in letters or other ornamental features, all wiring and tubing shall be kept free and insulated therefrom.

9.2 Dimensions

No roof sign shall exceed the following heights on buildings of heights:

<i>Sl No.</i>	<i>Height of Building</i>	<i>Height of Sign Max</i>
i)	Not exceeding four storeys or 18 m	2 m
ii)	Five to eight storeys or exceeding 18 m but not exceeding 36 m	3 m
iii)	Exceeding eight storeys or 36 m, provided that in calculating the height of such signs, signs placed one above the other, or on planes at different levels of the same building shall be deemed to be one sign, whether or not such signs belong to different owners	5 m

9.3 Location

- a) No roof sign shall be so placed on the roof of any building as to prevent free passage from one part of the roof to another.
- b) No roof sign shall be placed on or over the roof of any building unless the entire roof construction is of non-combustible material.

9.4 Projection

No roof sign shall project beyond the existing building line of the building of which it is erected or shall extend beyond the roof in any direction.

9.5 Supports and Anchorage

Every roof sign shall be thoroughly secured and anchored to the building on or over which it is erected. All loads shall be safely distributed to the structural members of the building.

9.6 For roof signs near the airports, the Directorate General of Civil Aviation should be consulted.

9.7 Painted roof signs shall conform to the requirements of **6** and **7**, where applicable.

10 VERANDAH SIGNS

10.1 Material

Every *Verandah* sign shall be constructed entirely of non-combustible material except as in **6.4**.

10.2 Dimensions

No *Verandah* sign exceed 1 m in height. No *Verandah* sign hanging from a *Verandah* shall exceed 2.5 m in length and 50 mm in thickness, except that *Verandah* box signs measuring not more than 200 mm in

thickness, measured between the principal faces of the sign and constructed entirely of metal wired glass may be erected.

10.3 Alignment

Every *Verandah* sign shall be set parallel to the building line, except that any such sign hanging from a *Verandah* shall be set at right angles to the building line.

10.4 Location

Verandah signs, other than hanging signs only, shall be placed in the following locations:

- a) Immediately above the eaves of the *Verandah* roof in such a manner as not to project beyond the rear of the roof gutter;
- b) Against but not above or below the *Verandah* parapet or balustrade provided such parapet or balustrade is solid and the sign does not project more than 20 cm from the outside face of such parapet or balustrade; or
- c) On the *Verandah* beams or parapets in the case of painted signs.

10.5 Height of Hanging *Verandah* Signs

Every *Verandah* sign hanging from a *Verandah* shall be fixed in such a manner that the lowest point of such sign is not less than 2.5 m above the pavement.

10.6 Projection

Except as provided for in 10.4, no *Verandah* sign shall extend outside the line of the *Verandah* to which it is attached.

11 WALL SIGNS

11.1 Material

Every wall sign exceeding 4 m² in area shall be constructed of non-combustible material except as in 6.4.

11.2 Dimensions

- a) The total area of any wall sign shall not exceed 20 m² for every 15 m of building frontage to the street to which such sign faces; except that in the case of a wall sign, consisting only of the name of a theatre or cinema, the total area of such sign shall not exceed 200 m².
- b) No wall sign which exceeds 30 m² in area shall be located on any wall not directly facing the road; provided that any such sign or signs shall not exceed 25 percent of the side wall area visible from the street.

11.3 Projection

No wall sign shall extend above the top of the wall or beyond the ends of the wall to which it is attached. At any place where pedestrians may pass along a wall, any wall sign attached thereto shall not project more than 7.5 cm therefrom within a height of 2.5 m measured from the level of such place.

11.4 Supports and Attachment

Every wall sign attached to walls shall be securely attached. Wooden blocks or anchorage with wood used in connection with screws, staples or nails shall not be considered proper anchorage, except in the case of wall signs attached to walls of wood.

12 PROJECTING SIGNS

12.1 Material

Every projecting sign and its support and framework shall be constructed entirely of non-combustible material.

12.2 Projection and Height

No projecting sign or any part of its supports or framework shall project more than 2 m beyond the building; however it shall not project beyond the plot line facing the street; when it projects into the street it shall be at clear height of 2.5 m from the road (*see* Part 3 'Development Control Rules and General Building Requirements' of the Code):

- a) The axes of all projecting signs shall be at right angles to the main face of the building. Where a V-construction is employed for the faces, the base of the sign against the building shall not exceed the amount of the overall projection.
- b) No projecting signs shall extend above the eaves of a roof or above the part of the building face to which it is attached.
- c) The maximum height of a projecting sign shall be related to the height of the building to which it is attached in the following manners:

<i>Sl No.</i>	<i>Height of Building</i>	<i>Height of Sign Max</i>
i)	Not exceeding four storeys or 18 m	9 m
ii)	Five to eight storeys or not exceeding 36 m	12 m
iii)	Exceeding eight storeys or 36 m	15 m

12.3 Supports and Attachment

Every projecting sign shall be securely attached to a building so that movement in any direction is prevented by corrosion-resistant metal brackets, rods, anchors, supports, chains or wire ropes so designed and arranged that half the number of such fixing devices may safely support the sign under all circumstances.

12.3.1 Staples or nails shall not be used to secure any projecting sign to any building.

12.4 Additional Loads

Projecting sign structures which could be used to support an individual on a ladder or other servicing device whether or not specifically designed for the servicing device shall be capable of supporting the anticipated additional load but in no case less than 500 kg concentrated horizontal load and 1 500 kg vertical concentrated load applied at the point of assumed loading or point of most eccentric loading. The building component to which the projecting sign is attached shall also be designed to support the additional loads.

13 MARQUEE SIGNS

13.1 Materials

Marquee signs shall be constructed entirely of metal or other approved non-combustible materials.

13.2 Height

Such sign shall not exceed 2 m in height, nor shall they project below the fascia of the marquee, nor lower than 2.5 m above the footpath.

13.3 Length

Marquee signs may extend the full length but in no case shall they project beyond the ends of the marquee.

14 SKY SIGNS

In the case of the sky signs, the regulations laid down by the Authority concerned shall apply.

15 TEMPORARY ADVERTISING SIGNS, TRAVELLING CIRCUS SIGNS, FAIR SIGNS AND DECORATIONS DURING PUBLIC REJOICING

15.1 Types

None of the following advertising signs shall be erected or maintained, other than as temporary signs erected in accordance with **15.2**:

- a) Any advertising sign which is painted on or fixed on to or between the columns of a *Verandah*;

- b) Any advertising sign which projects above or below any fascia, bearer, beam or balustrade of a *Verandah* or balcony;
- c) Any advertising sign which is luminous or illuminated and which is fixed to any fascia bearer, beam or balustrade of any splayed or rounded corner of a *Verandah* or balcony;
- d) Any streamer sign erected across a road;
- e) Any sign not securely fixed so as to prevent the sign swinging from side to side;
- f) Any advertising sign made of cloth, paper mache, or similar or like material but excluding licensed paper signs on hoardings or fences;
- g) Any advertising sign on a plot used or intended to be used exclusively for residential purposes, other than a brass plate or board preferably not exceeding 600 mm x 450 mm in size, affixed to the fence or entrance door or gate of a dwelling, and in the case of a block of flats, affixed to the wall of the entrance hall or entrance door of any flat; and
- h) Any sign on trees, rocks, hillsides and similar natural features.

15.2 Requirements for Temporary Signs

15.2.1 All temporary advertising, travelling circus and fair signs and decorations during public rejoicing shall be subject to the approval of the Authority and shall be subjected to the approval of the Authority, and shall be erected so as not to obstruct any opening and to minimize fire risk.

15.2.2 The advertisement contained on any such sign shall pertain only to the business, industry or other pursuit conducted on or within the premises on which such sign is erected or maintained. Temporary advertising signs shall be removed as soon as torn or damaged and in any case within 14 days after erection unless extended.

15.2.3 The Authority shall be empowered to order the immediate removal of any temporary advertising sign or decoration, where, in its opinion such action is necessary in the interests of public amenity and safety.

15.2.4 Pole Signs

Pole signs shall be constructed entirely of non-combustible materials and shall conform to the requirements for ground or roof signs as the case may be (*see 8 and 9*). Such signs may extend beyond the street line if they comply with the provisions for projecting signs (*see 12*).

15.2.5 Banner and Cloth Signs

Temporary signs and banners attached to or suspended

from a building, constructed of cloth or other combustible material shall be strongly constructed and shall be securely attached to their supports. They shall be removed as soon as torn or damaged, and in no case later than 14 days after erection; except, that permits for temporary signs suspended from or attached to a canopy or marquee shall be limited to a period of 10 days.

15.2.6 Maximum Size

Temporary signs shall not exceed 10 m² in area.

15.2.7 Projection

Temporary signs of cloth and similar combustible construction shall not extend more than 300 mm over or into a street or other public space except that such signs when constructed without a frame may be supported flat against the face of a canopy or marquee or may be suspended from the lower fascia thereof but shall not extend closer to the footpath than 2.5 m.

15.2.8 Special Permits

All temporary banners suspended from building or hung on poles, which extend across streets or other public spaces shall be subject to special approval of the Authority.

15.2.9 Bill boards set up by the Authority shall be used for temporary signs, symbols, bills for entertainment, etc, so that other walls of the city are not defaced.

15.2.9.1 Bills for entertainment and other functions shall not be affixed on to building walls other than the bill boards (*see 15.2.9*). The organization responsible for such bills and posters shall be held responsible for any such defacement and non-removal of signs.

16 ADDITIONAL GUIDELINES FOR SIGNS IN URBAN AND RURAL AREAS

16.1 Erecting maintaining and owning signs in rural areas shall be encouraged so as to boost the information and economic status of the rural population.

16.2 The tolerance criteria for the permission granted towards putting up any signs for any urban area shall be as given in **16.2.1** to **16.2.4**.

16.2.1 Small Towns

The traffic hazards in small towns are few and the defacement due to excessive advertising signs has not occurred. Therefore, orderly development of signs may enliven the town environment and boost the economy. The tolerance here may be high. The following guidelines may be followed for signage:

- a) *Advertising sign* — Electric sign, ground sign, building sign, illuminated sign, sky sign and temporary sign are permissible.

- b) *Directional sign* — Electric sign, ground sign, building sign, illuminated sign and temporary sign are permissible while sky sign is not permissible.
- c) *Informational sign* — Electric sign, ground sign, building sign, illuminated sign and temporary sign are permissible while sky sign is not permissible.
- d) *Identification sign* — Electric sign, ground sign, building sign, illuminated sign and temporary sign are permissible while sky sign is not permissible.
- e) *Regulatory sign* — Electric sign, ground sign, illuminated sign and temporary sign are permissible while building sign and sky sign are not permissible.

16.2.2 Medium Towns

The traffic hazards in medium towns are few and the defacement due to excessive advertising signs has not occurred. Proper design, erection and maintenance of the signs shall be encouraged. The following guidelines may be followed for signage:

- a) *Advertising sign* — Electric sign, ground sign, building sign, illuminated sign, sky sign and temporary sign are permissible.
- b) *Directional sign* — Electric sign, ground sign, illuminated sign are permissible while building sign, sky sign and temporary sign are not permissible.
- c) *Informational sign* — Electric sign, ground sign, illuminated sign, and temporary sign are permissible while building sign and sky sign are not permissible.
- d) *Identification sign* — Electric sign, ground sign, building sign, illuminated sign and temporary sign are permissible while sky sign is not permissible.
- e) *Regulatory sign* — Electric sign, ground sign, illuminated sign and temporary sign are permissible while building sign and sky sign are not permissible.

16.2.3 Large Cities

The traffic is high and hazards of accidents are many in large cities. Defacement of buildings, roads and the urban spaces due to advertisements has to be checked. Therefore, the permissivity and tolerance for erecting signs is very low. The following guidelines may be followed for signage:

- a) *Advertising sign* — Electric sign, ground sign, illuminated sign and sky sign are permissible while building sign and temporary sign are not permissible.

- b) *Directional sign* — Ground sign, illuminated sign are permissible while electric sign, building sign, sky sign and temporary sign are not permissible.
- c) *Informational sign* — Ground sign, illuminated sign, building sign and temporary sign are permissible while electric sign and sky sign are not permissible.
- d) *Identification sign* — Electric sign, ground sign, building sign, illuminated sign and temporary sign are permissible while sky sign is not permissible.
- e) *Regulatory sign* — Ground sign, illuminated sign and temporary sign are permissible while electric sign, building sign and sky sign are not permissible.

17 ENVIRONMENTAL GRAPHICS FOR CITYSCAPE

The urban environment may be susceptible to confusion and chaos due to improper graphics, hoardings and advertisements. Therefore, the signage should be installed following requisite guidelines laid down keeping the functional, safety and aesthetic aspects in view.

The scale of the project should also be considered for implementing signage design. In urban design/planning projects and landscape projects on a large scale, the following criteria should be followed for signs and outdoor display structures:

16.2.4 Mega and Metro Cities

The traffic hazards in mega and metro cities are many and the defacement due to excessive advertising signs has marred the urban environment. The density of population is very high and the danger of greater loss of life due to disasters is self evident. Therefore, the permissivity for erecting signs is very low and no tolerance exists for law breakers. The following guidelines may be followed for signage:

- a) *Advertising sign* — Electric sign, ground sign, illuminated sign and sky sign are permissible while building sign and temporary sign are not permissible.
- b) *Directional sign* — Ground sign, illuminated sign are permissible while electric sign, building sign, sky sign and temporary sign are not permissible.
- c) *Informational sign* — Ground sign, illuminated sign and temporary sign are permissible while electric sign, building sign and sky sign are not permissible.
- a) Aesthetic and harmonious development of the visual environment.
- b) Signage for the persons with disabilities at all level/grade changes, entry points to buildings and public conveniences and facilities; including braille and tactile signage used for the benefit of the visually impaired at all important nodes, entrances and routes (see Part 3 'Development Control Rules and General Building Requirements' of the Code).
- c) Environmental graphics should be creatively designed to cater to the basic function of information, identity and way finding, with the objective of improvement of urban scape.
- d) Safety aspects.
- e) Protection of trees and other vegetation from harm due to signs.

ANNEX A

(Clause 3.1.2)

SPECIMEN FORM FOR APPLICATION FOR PERMIT TO ERECT, RE-ERECT OR ALTER ADVERTISING SIGN

1. Type of sign _____
2. Location¹⁾: _____
 - a) Building/premises _____
 - b) Location of building/premises with respect to neighbouring streets _____
3. Dimensions and details of the sign¹⁾ _____
4. Materials used for different parts _____
5. Electrical and lighting details¹⁾ _____
6. Structural details showing also supporting framework and anchorages¹⁾ _____
7. Mode of operation _____

Name and address of the applicant

Name and address of the owner of the building/premises

Signature _____

Signature _____

Date _____

Date _____

¹⁾ Plans as desired in 3.1.2 (b) are enclosed.

LIST OF STANDARDS

The following list records those standards which are acceptable as ‘good practice’ and ‘accepted standards’ in the fulfillment of the requirements of this Code. The latest version of a standard shall be adopted at the time of enforcement of the Code. The standards listed may be used by the Authority for conformance with the requirements of the referred clauses in the Code.

In the following list, the number appearing in the first column within parentheses indicates the number of the reference in this Section.

<i>IS No.</i>	<i>Title</i>
(1) 3808 : 1979	Method of test for non-combustibility of building materials (<i>first revision</i>)
(2) 2553 (Part 1) : 1990 (Part 2) : 1992	Specification for safety glass General purpose (<i>third revision</i>) For road transport
(3) 401 : 2001	Code of practice for preservation of timber (<i>fourth revision</i>)

NATIONAL BUILDING CODE OF INDIA

PART 11 APPROACH TO SUSTAINABILITY

BUREAU OF INDIAN STANDARDS

CONTENTS

FOREWORD	... 3
1 SCOPE	... 7
2 TERMINOLOGY	... 7
3 APPROACH TO SUSTAINABILITY	... 10
4 APPLICABILITY OF THIS PART	... 13
5 IMPLEMENTATION OF THIS PART	... 13
6 SITING, FORM AND DESIGN	... 13
7 EXTERNAL DEVELOPMENT AND LANDSCAPE	... 15
8 ENVELOPE OPTIMIZATION	... 23
9 MATERIALS	... 38
10 WATER AND WASTE MANAGEMENT	... 53
11 BUILDING SERVICES OPTIMIZATION	... 61
12 CONSTRUCTIONAL PRACTICES	... 75
13 COMMISSIONING, OPERATION, MAINTENANCE AND BUILDING PERFORMANCE TRACKING	... 82
ANNEX A DESIGN STRATEGIES AS PER CLIMATE ZONES FOR VARIOUS SEASONS	... 85
ANNEX B PRESCRIPTIVE METHOD FOR ENVELOPE OPTIMIZATION	... 87
ANNEX C TRADE-OFF METHOD FOR ENVELOPE OPTIMIZATION	... 88
ANNEX D WHOLE BUILDING ANALYSIS METHOD FOR ENVELOPE OPTIMIZATION	... 90
LIST OF STANDARDS	... 94

FOREWORD

This Code (Part 11) covers the parameters required to be considered for planning, design, construction, operation and maintenance of buildings and those relating to land development, from the point of view of sustainability.

From the dawn of civilization, our ancestors were concerned with preservation and sustenance of environment. The ancient *Vedas* have several references in them on environmental protection, ecological balance, weather cycle, rainfall phenomenon, hydrological cycle and related subjects. Seers, even at those times, recognized that changes caused due to indiscreet human activities could result in imbalances in seasons, rainfall patterns, crops and atmosphere and degrade the quality of water, air, and earth resources. Basham, in 'The Wonder that was India', describes how palaces in Mauryan dynasty in second century B.C., were exquisitely built from carved wood of local deodars. In later years the monasteries, temples and *dharmashalas* were built with locally available stones and these have withstood the ravages of time. Edwin Arnold, in 'The Light of Asia', describes *Vishramvan*, the palace built with local marble and alabaster for prince Siddharth. The epic Mahabharata describes palace built by Vishwakarma. *Kashi Vishwanath* Temple in Varanasi was built more than a thousand years ago. Many other ancient monuments in various parts of India are classic examples of sustainable buildings.

The *Taj Mahal*, built more than four hundred years ago, can accommodate hundreds of people with no suffocation, as the stone *jalis* in the facia induce air movement and enable natural ventilation. The fort in *Mandu* has elaborate rainwater harvesting techniques. *Havelis* in northern India were invariably built around a central courtyard, which brought daylight to all nooks and corners, but the heat was kept out. Many forts and *havelis* have elaborate provision for evaporative cooling, using *khas*-screens and rainwater stored at higher plateaus. Sustainability and sustainable buildings have been the way of life in India.

It was not just palaces, monasteries and temples that were built on the platform of sustainable practices. The awareness was innate and intuitive, guided by a clear understanding of nature and driven by total alignment with environment, with the resolve not to harm nature but to respect and revere it, and to live in harmony with it. A reflection of this is visible in the locally evolved climate-responsive architecture that blended with social and cultural mores, leaving behind lasting concepts of building forms and human settlements. These buildings provided comfort to the occupants. They were passive in approach with no external intervention, which in modern times have become quite desirable. Diverse climatic conditions in our country resulted in evolution of different fabrics of built form, with the commonality being the focus on harmony with nature. It becomes obvious to see why all the scriptures, literature, life styles and cultural ethos made reference to the *Panchabhoothas*, which represent five elements of nature, thus blending the architecture and habitats with nature. Thus, sustainability, and sustainable buildings have been the way of life in India.

Less than a hundred years ago, industrial revolution came to India and changed many of these traditional sustainable practices in Indian buildings. The insatiable thirst for progress and comfort at any cost, altered the equation with nature forever. Concrete, steel, glass and later plastics became the dominant construction materials, beyond stone and wood of yesteryears. Power supply, artificial lighting, water supply and disposal, and thermal environmental control within built environment, were desired and obtained.

The new civilizations grew along the river banks, always regarding rivers as sacred. With the industrial revolution, untreated water, effluents from chemical industries and organic waste were discharged into rivers and water bodies, destroying our precious sources of water for domestic use. In addition, the unsustainable development and usage of buildings have led to huge construction and demolition waste, and municipal solid waste during their operation, which today have become a major problem.

Modern buildings in India consume about 25 to 30 percent of total energy, and up to 30 percent of fresh potable water, and generate approximately 40 percent of total waste. India is now entering the phase of rapid urbanization. Various studies indicate that by 2050, the built up area of India may become four times the current mass, which may pose a major challenge in preserving our fragile environment. Although the present energy consumption per

capita in India is a fraction of that of most developed nations, but with its projected growth, unless enough measures are taken, it may lead to acceleration of environment degradation, contributing to increased carbon footprint leading to global warming and climate change, resource scarcity and inequitable development.

Sustainable buildings have demonstrated reduction in energy and water consumption to less than half of the present consumption in conventional buildings and complete elimination of the construction and operational waste through recycling. The Indian way of life is *Aparigraha* (minimum possession), conservation (minimum consumption) and recycling (minimum waste). These three attributes are the guiding principles for sustainable buildings as well. With these attributes and its rich heritage, India can make a substantial contribution in this field and eventually lead the world on the path of sustainability.

Developed nations' approach to sustainability generally concentrates on energy efficiency through high technology innovations, and use of products, materials and designs with lower embodied energy. Their green ratings are based on intent, which implies expert inputs and simulation which often can be counter intuitive such as the envisaged load and effective use of energy efficient appliance. Indian construction industry will do better through use of products, materials and designs with lower embodied energy and our traditional wisdom and practices, building in harmony with nature through regional common knowledge, consuming as little as necessary, applying low cost technology innovations, using recycled materials, and recognizing performance (not intent) through easily measurable parameters, wherever feasible. If required, the above approach may be supplemented with an appropriate blend of the emerging and sustainable technology innovations. It is particularly emphasized that the hazard of construction and demolition waste should be properly attended to in view of increased construction and redevelopment activities in the country anticipated in future. This would require that such waste is preferably used at site and the balance, if any, may be sent to recycling plant which is closest to the site.

The Sectional Committee, reviewed the contents of the 2005 version of the Code and observed that due consideration had been given to these important dimensions in building planning, design and construction and during operation through provisions of effective utilization of natural light and ventilation; increased use of renewable energy, material selection including recyclability and reusability aspects; use of low gestation plantations and agriculture and industrial wastes; design approach; proper management practices; efficient electrical and other building services and plumbing services; energy conservation; rainwater harvesting, etc. All these have been duly interwoven throughout the Code addressing both the embodied energy and the operational energy involved, as also showing sensitivity towards the concerns such as ozone depletion, global warming, etc. The Committee, however, felt that in keeping with the present needs as well as likely future scenario, it might be appropriate to completely review all such aspects and give them a special and separate identity in the form of Part of the Code covering approach to sustainability relating to buildings and built environment. Aiming towards such objectives, the Sectional Committee first formulated this Part and incorporated in the 2005 version of the Code through Amendment No. 1 to the Code.

This revision has been taken up to further review this Part and update it particularly in view of the modifications being incorporated in other Parts/Sections in this revision of the Code, to bring coherence among the provisions of this Part and other revised Parts/Sections. The significant modifications incorporated in this revision are:

- a) Inclusion of definitions of a number of additional terms such as surface coefficient, surface resistance, thermal transmission and total thermal resistance.
- b) Greater emphasis on ensuring barrier free design for universal accessibility, as part of approach to sustainability.
- c) Review of provisions on materials and technologies for sustainability and their updating, wherever required.
- d) Inclusion of guidelines for selection of window types.
- e) Modification of the clause on refrigerants for air conditioning to include refrigerants, considering sustainability aspects.
- f) Inclusion of provision for preparation of overall water balance chart, as part of water and waste management.

This Part of the Code provides a comprehensive set of requirements, intended to reduce the negative impact of buildings on the natural environment. It can be readily used by the owners, developers/builders, architects, engineers, building services engineers and other building professionals as well as by manufacturers of building materials apart from the Authorities concerning land and building development, government and private construction agencies and academic and research institutions. The intent of this Part of the Code is to highlight sustainability measures including those referred to in different Parts/Sections of the Code as may be required as well as to define

comprehensive sustainability standards for the building construction and related built environment.

The approach to sustainability is founded on principles consistent with this Code, to adequately protect public health, safety and welfare and to provide requirements that do not unnecessarily increase construction cost nor restrict the use of new / innovative materials, products or methods of construction. The benefits of incorporating measures listed in this Part are not only environment friendly, but also result in much better health and productivity of occupants, at minimal additional initial cost over the cost of conventional buildings, while substantially reducing the life cycle cost. This minimal additional cost is offset during a few years usage of the buildings, and vast advantage in cost is accrued during the life cycle of the building.

The measures of sustainable buildings described in this Part, set performance thresholds and incorporate features that allow Authority to customize requirements according to local geographical conditions, environmental priorities and agenda. These are not specific to any rating system and are not intended to provide a single metric indication of overall building performance. The flexibility of these provisions allows the practitioners to easily exercise their judgment in holistically and objectively applying the underlying principles of sustainability to a development or building facility, considering its functionality and required comfort level.

The provisions of this Part of the Code are without prejudice to the concerned statutory provisions including those given in various Acts and Rules and Regulations framed thereunder.

The information contained in this Part of the Code has been brought in coherence with the provisions contained in other parts of the Code, as also with the concerned Indian Standards on various areas. In the formulation of this Part, efforts have been made to take into cognizance the various latest applicable practices followed in the country and abroad, relevant to sustainability in buildings. This has been done by taking into consideration the publications of the American Society for Heating, Refrigeration, Air conditioning Engineers; American Society for Testing and Materials; Bureau of Energy Efficiency, India; Indian Green Building Council; Indian Society for Heating, Refrigeration, Air conditioning Engineers; International Organisation for Standardisation; and The Energy and Resources Institute, India.

All standards cross-referred to in the main text of this Part, are subject to the revision. The parties to agreement based on this Part are encouraged to investigate the possibility of applying the most recent editions of the standards.

For the purpose of deciding whether a particular requirement of this Part is complied with, the final value, observed or calculated, expressing the result of a test or analysis, shall be rounded off in accordance with IS 2 : 1960 'Rules for rounding off numerical values (*revised*)'. The number of significant places retained in the rounded off value should be the same as that of the specified value in this Part of the Code.

NATIONAL BUILDING CODE OF INDIA

PART 11 APPROACH TO SUSTAINABILITY

1 SCOPE

1.1 This Part 11 covers the parameters required to be considered for planning, design, construction, operation and maintenance of buildings and those relating to land development, from sustainability point of view.

1.2 This Part of the Code is a supplement to all other Parts/Sections of the Code and shall be read along with the same.

1.3 For all buildings and facilities open to and used by the public, including all forms of public housing by the government/civic bodies and private developers, barrier free access and movement within and around buildings, for persons with disabilities and of different age groups, shall be ensured in accordance with Part 3 'Development Control Rules and General Building Requirements' of the Code.

2 TERMINOLOGY

2.0 For the purpose of this Part of the Code, the definitions given below shall apply.

2.1 Adaptive Thermal Comfort — The comfort that relates indoor design temperatures or acceptable temperature ranges to outdoor meteorological and climatological parameters.

NOTE — The adaptive thermal comfort model refers to the concept of specifying indoor comfort temperature set points based on the physiological, behavioural and psychological measures that the occupants take, voluntarily or involuntarily, to adapt themselves to the thermal environment and achieve comfort.

2.2 Authority Having Jurisdiction — The Authority which has been created by a statute and which, for the purpose of the Code/Part, may authorize a committee or an official or an agency to act on its behalf; herein after called the 'Authority'.

2.3 Biodiversity — The variability among living organisms from all sources including terrestrial, marine and other aquatic ecosystems and the ecological complexes of which they are a part; this includes diversity within species, between species, and of ecosystems.

2.4 Building Environment — The surrounding in which a building operates, including air, water, land, natural resources, flora, fauna, human beings and their inter-relations.

2.5 Building Performance — The ability of a building to fulfil required functions under intended use conditions or behaviour when in use.

2.6 Built Environment — The collection of man-made or induced physical objects located in a particular area or region.

NOTE — When treated as a whole, the built environment typically is taken to include buildings, external works (landscape areas), infrastructure and other construction works within the area under consideration.

2.7 Disaster — It is a catastrophe, mishap, calamity or grave occurrence in any area, arising from natural or man-made causes, or by accident or negligence which results in substantial loss of life, or human suffering or damage to, and destruction of, property or damage to or degradation of environment, and is of such a nature of magnitude as to be beyond the coping capacity of the community of the affected area.

2.8 Ecological Footprint — The impact of a person or community, expressed as the amount of land required to sustain their use of natural resources.

2.9 Ecosystem — The community of biological organisms and their physical environment, functioning together as an interdependent unit within a defined area.

NOTE — For the purpose of this definition, humans, animals, plants, and microorganisms are individually all considered biological organisms.

2.10 Embodied Energy — The sum total of energy that is used to extract, process, package, transport, and install the material in the building.

NOTE — Embodied energy data is often collected using input and output analysis.

2.11 Emissivity(E) — The ratio of rate of heat emitted by a surface as compared to that of an absolutely black surface under similar conditions. It varies with the temperature of the emitting surface.

2.12 Environmental Impact — Any change to the environment, whether adverse or beneficial, wholly or partially, resulting from environmental aspects of a built environment.

2.13 Green Roof System — An assembly that supports an area of planting/landscaping, built up on a waterproofed substrate at any level that is separated from the natural ground by a human made structure.

2.14 Heat Island Effect — A phenomenon in which air and surface temperature of an area are higher than nearby areas due to the replacement of natural land cover with pavement, building, and other infrastructure.

2.15 Horizontal Sun Angle (HSA) — The horizontal angle between the normal of the window and the sun azimuth angle at a given time (*see Fig. 1*).

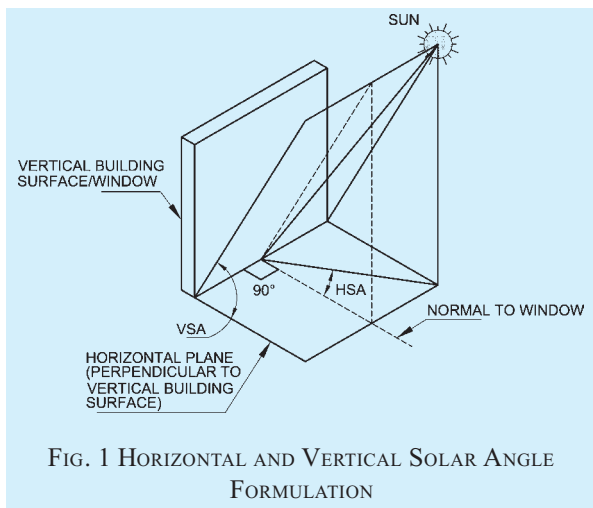

2.16 Indoor Air Quality (IAQ) — The nature of indoor air that affects the health and well-being of building occupants.

2.17 Indoor Environment Quality (IEQ) — The condition or state of the indoor environment.

2.18 Life Cycle Assessment (LCA) — A method of evaluating a product by reviewing the ecological impact over the life of the product.

NOTE — At each stage, the product and its components are evaluated based upon the materials and energy consumed, and the pollution and waste produced. Life stages include extraction of raw materials, processing and fabrication, transportation, installation, use and maintenance, and reuse/recycling/disposal.

2.19 Light Shelf — An architectural element that allows daylight penetration in a building. It is usually a horizontal light-reflecting overhang on a window or opening and is placed above eye-level and has a high-reflectance upper surface. This surface reflects daylight onto the ceiling and deeper into a space.

2.20 Non-renewable Resource — A resource that exists in a fixed quantity that cannot be replenished on a human time scale.

NOTE — Non-renewable resources have the potential for renewal only by the geological, physical and chemical processes taking place over hundreds of millions of years. Non-renewable resources exist in various places in the earth's crust. Examples include iron ore, coal, and oil.

2.21 Renewable Resource — A resource that is available naturally, harnessed, and can be replenished.

NOTE — Sustainable use of renewable resource implies that the rate of replenishment, or cleansing takes place at a rate equal to or greater than the current rate of depletion of that resource. Examples include trees in forest, grasses in grassland, and fertile soil.

2.22 Reuse — Using a material, product or component of the waste stream in its original form more than once.

2.23 Recycling — A process to convert discarded

materials that would otherwise become waste, into valuable resources.

2.24 Skylight Roof Ratio (SRR) — The ratio of the total skylight area of the roof, measured to the outside of the frame, to the gross exterior roof.

2.25 Solar Heat Gain Coefficient (SHGC) — The fraction of incident solar radiation admitted through a fenestration, both directly transmitted, and absorbed and subsequently released inward through conduction, convection and radiation (see Fig. 2).

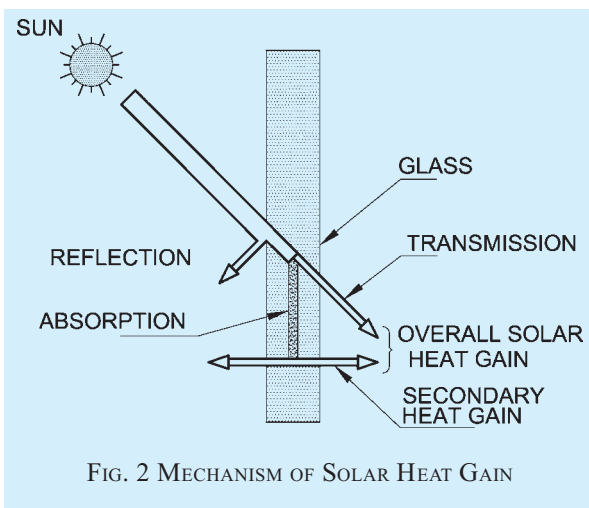

2.26 Solar Reflectance Index (SRI) — A measure of material's ability to reject solar radiation, as shown by a small temperature rise.

NOTE — SRI of standard black surface (having reflectance of 0.05 and emittance of 0.9) and a standard white surface (of reflectance 0.8 and emittance 0.9) are taken as 0 and 100, respectively.

2.27 Surface Coefficient (f) — The thermal transmission by convection, conduction and radiation from unit area of the surface, for unit temperature difference between the surface and the surrounding medium. It is expressed in $W/m^2 K$.

NOTE — The value of f depends on many factors, such as, air or fluid movement in contact with the surface, roughness and emissivity of the surface and upon the temperature and nature of surroundings.

2.28 Surface Resistance ($1/f$) — The reciprocal of surface coefficient. It is expressed in m^2K/W .

2.29 Sustainability — The state in which components of ecosystem and their functions are maintained for the present and future generations.

NOTES

1 Sustainability is the goal of sustainable development and can result from the application of the concept of sustainable development.

2 In building construction, it relates to how the attributes of the activities, materials/products or services used in construction work, or the use of construction works, contribute to the

maintenance of ecosystem components and functions for future generations.

3 While the challenge of sustainability is global, the strategies for sustainability in building construction are local and may differ in context and content from region to region.

4 'Components of ecosystem' includes plants and animals, as well as humans and their physical environment. For humans, this includes a balancing of key elements of human needs namely the economic, environmental, social and cultural conditions for societies' existence.

2.30 Sustainable Buildings — A building that meets the specified building performance requirements while minimizing disturbance to and improving the functioning of local, regional, and global ecosystem both during and after its construction and specified service life.

NOTE — A sustainable building optimizes efficiencies in resource management and operational performance; and, minimises risks to human health safety and the environment.

2.31 Sustainable Development — The development that meets the need of the present without compromising the ability of future generations to meet their own.

2.32 Thermal Absorptivity — A factor indicating the relative amount of radiation absorbed by a surface as compared to an absorbing black body under the same conditions. Its value is dependent upon the temperature of the source and of the receiving surface.

2.33 Thermal Capacity — The amount of heat necessary to raise the temperature of a given mass by 1°C. Numerically, the thermal capacity per unit area of surface is the sum of the products of the mass per unit area of each individual material in the roof, wall or floor surface multiplied by its individual specific heat.

2.34 Thermal Conductance (R) — The thermal transmission of a single layer structure per unit area divided by the temperature difference between the hot and cold faces. It is expressed in W/m² K.

NOTE — Thermal conductance is a measure of the thermal transmission per unit area through the total thickness of the structure under consideration. Thermal conductivity on the other hand refers to unit thickness of material. Further, this term applies only to a single layer of material and not to a composite insulation or to a structure made up of several layers of materials or medium.

2.35 Thermal Conductivity (k) — The quantity of heat in the steady state conditions flowing in unit time through a unit area of a slab of uniform material thickness of infinite extent and of unit thickness, when unit difference of temperature is established between its faces. Its unit is W/mK.

NOTE — Thermal conductivity is a characteristic property of a material and its value may vary with a number of factors, including density, porosity, moisture content, fibre diameter, pore size, type of gas in the material, mean temperature and outside temperature range. The conductivity value varies from

0.03 W/mK for insulators to 400 W/mK for metals. Materials with lower conductivity are preferred, as they are better insulators and reduce the external heat gains from the envelope or loss of internal heat to outside cold environment.

2.36 Thermal Comfort — That condition of mind which expresses satisfaction with the thermal environment and is assessed by subjective evaluation.

2.37 Thermal Reflectivity — The ratio of the reflected heat to that of the total heat incident on a surface at a certain mean temperature range.

2.38 Thermal Resistance (R) — The reciprocal of thermal conductance. For a structure having plane parallel faces, thermal resistance is equal to thickness (*L*) of the structure divided by thermal conductivity (*k*).

$$R = \frac{L}{k}$$

NOTE — The usefulness of the quantity is that when heat passes in succession through two or more components of the building units, the resistance may be added together to get the total resistance of the structure.

2.39 Thermal Resistivity (1/k) — The reciprocal of thermal conductivity. It is expressed in mK/W.

2.40 Thermal Transmission or Rate of Heat Flow (q) — The quantity of heat flowing in unit time under the conditions prevailing at that time. Its unit is W.

2.41 Thermal Transmittance (U) — Thermal transmission through unit area of the given building unit divided by the temperature difference between the air or other fluid on either side of the building unit in steady state conditions. It is also called as *U*-value. Its unit is W/m²K.

NOTE — Thermal transmittance differs from thermal conductance in so far as temperatures are measured on the two surfaces of a material or structure or building unit in the latter case and in the surrounding air or other fluid in the former case. Thermal conductance is a characteristic of the structure or building unit whereas thermal transmittance depends on conductance and surface coefficients of the structure or building unit under the conditions of use.

2.42 Total Thermal Resistance (R_T) — It is the sum of the surface resistances and the thermal resistance of the building unit itself. It is expressed in m²K/W.

2.43 Tropical Summer Index (TSI) — The temperature of calm air at 50 percent relative humidity which imparts the same thermal sensation as the given environment. TSI (in °C) is expressed as:

$$TSI = 0.745t_g + 0.308t_w - 2.06\sqrt{v + 0.841}$$

where

- t_g* = globe temperature, °C;
t_w = wet bulb temperature, °C; and
v = wind speed, m/s

2.44 Vertical Solar Angle (VSA) — The angle that a plane containing the bottom two points of the window and the centre of the sun makes with the ground when measured normal to the shaded surface (*see* Fig. 1).

2.45 Visual Light Transmittance (VLT) — The ratio of total transmitted light to total incident light.

2.46 Volatile Organic Compound (VOC) — The carbon compounds (excluding carbon monoxide, carbon dioxide, carbonic acid, metallic carbides or carbonates, and ammonium carbonate) which participate in atmospheric photochemical reactions. The compounds vapourize at normal room temperatures.

2.47 Waste — Substances or objects which the holder intends or is required to dispose of.

3 APPROACH TO SUSTAINABILITY

3.1 Need for Sustainable Development

Building construction, occupancy and additions/alterations including preventive and remedial maintenance are always energy and material intensive. Large amount of primary form of natural materials, water, air, energy, etc, are consumed. The energy and material resources required for a building can be categorised as embodied energy, recurring operation energy, refurbishment energy, and end of life disposal. These elements and their use are inter-dependent. There is need for integrated approach of considering them all together in general design development and construction practice. However, conventional approach towards utilizing them is independent of each other and results in very low efficiency in material and resource use.

With increasing urbanization and rapid rise in people's economic level and consumption pattern in many parts of the country, there is an increasing trend to consume more natural resources per capita. This is evident from the aspirational lifestyles and resulting changing tastes and expenditure patterns of individuals and societies. This is equally witnessed from modern construction trends and changing sky lines of cities that bear no resemblance to local climate and resource availability. This is constantly putting tremendous pressure on fragile ecosystem by over-exploitation of natural resources adversely affecting biodiversity of our planet. Realizing this fact, there are efforts for a changing approach towards nature from 'humanization of nature' to 'naturization of human' and more recently towards sustainable development. The concept is to ensure that every living being on earth have equal opportunity to utilize the natural resources for survival and mutual sustenance.

To achieve this, it is important to accept the major challenge in controlling and judiciously using natural resources to shrink ecological footprint. The way to achieve this is by holistically planning our growth needs, one of which is construction and combining them with need based economy, but at the same time without compromising on functionality and essential comforts.

The basic components of building facility, their inter-relation, tradeoffs and effect on surrounding micro-climatic conditions have to be estimated, to achieve the harmony between buildings and ecological surroundings. Ideally a building should symbiotically fit within prevalent natural cycles. It is necessary to assess the association of various factors involved, rationalizing the impact of construction on neighbourhood and/or building micro-climatic conditions to discern sustainability in the built environment.

3.2 Elements of Sustainability

The generalized design process towards sustainability should creatively address the following considerations:

- a) Set the design parameters to be implemented to be equal to or higher than benchmarking standards given in this Code.
- b) Make the basic performance requirements and set standards, applicable/ selectively adaptable to the climatic zone and geological conditions in which the construction is proposed.
- c) Have deep understanding of requirements of performance and human comfort in a building and its surroundings, considering building type and use, quality of building and plumbing services as desired, needs of persons with disabilities and of different age groups, and other parameters.
- d) Question the need, identify their optimum levels in long term scenario, and take the design provisions to that level only.
- e) Ensure what is sustainable today, remains that way in decades to come, and ensure the required performance levels of systems designed. If required extensive damages done could also be rectified/reversed in course of time.
- f) Ensure that sustainability is not only in parts, but also a holistic effort and local action should contribute to sustainability.
- g) Make efforts to maximize the use of traditional wisdom in design, wherever applicable, as it represents the knowledge about the long-term behaviour of materials and technology and their strengths as well as weaknesses.

- h) While having an open approach, assess new materials and technologies for their long-term impact in the context of the country and its development priorities, before accepting them for use.
- j) Take decision making processes to measurable levels wherever feasible, in order to make informed choices. Also by willing to accept limitations of decisions made.
- k) Take the savings' benchmark targets closer to the minimum consumption standards; undertake value engineering exercises for deciding among the options.

This process emphasizes the requirement of bottom up approach which invariably considers microclimatic and cultural conditions around.

NOTE — The 'bottom up approach' concentrates more on how little is consumed; pursue deep understanding of sustainability; uses low technology innovations, materials and practices; recognizes performance to be more important than intent; and necessitates the use of common knowledge and common sense in design decisions. On the contrast, the 'top down approach' concentrates more on how much energy is saved; accepts the understanding of sustainability, may not be developed indigenously, more readily; uses high technology innovations, materials and practices; is driven by green brand and accompanying recognitions based on intent; and necessitates expert inputs and simulations.

The design process itself can play a significant role in creating built environment respecting all principles of sustainable development. This has to take into account various climatic zones (like hot-dry, warm-humid, composite, temperate and cold climates) as well as sun path movements, location (prone to tsunami, hurricane, etc), annual wind directions and geological conditions in the design of building, its orientations, wall and roof materials combinations, space layout, fenestrations and landscape. A solar passive architecture that places minimum energy demand in maintaining thermal comfort should be explored foremost.

The sustainable design process should be based on the principles of universal design as per Part 3 'Development Control Rules and General Building Requirements' of the Code, so as to address accessibility needs of persons with disabilities and persons of different age groups.

Functional requirements of buildings have to also measure up to the required comfort levels demanded for all types of user requirements.

3.3 Life Cycle Sustenance

The process flow from concept, design, construction, commissioning, operation and maintenance, and also decommissioning and disposal at the end of useful life of structure, should be planned and important steps

chalked out for sustainable development. This should also take care of possible reuse/recycle of materials/components/structure or parts thereof. Ideally close the loop (cradle to grave) with regards to resources originally used.

3.4 Technology Options

The consequential building envelope to create harmonious development and productive living environment with neighbourhood and building environments poses one of the biggest challenges in selection of building materials, technologies and practices. It may be a combination of natural and manmade materials with least embodied energy and also leading to use of rapidly renewable resources. The trade-off between choice of the materials and technologies and their effect on environment has to be balanced with the aim of a closed-loop system. As a holistic approach, all efforts should be made towards,

- a) encouraging and harnessing building materials out of agricultural, industrial and bio-wastes, which have an enormous scope for regeneration.
- b) encouraging indigenous environment-friendly and acceptable cost-effective technologies and practices in identifying and pursuing sustainable developments amenable to local, cultural and resource diversity.
- c) identifying and encouraging appropriate technologies for more research and development applications.
- d) making building construction more indigenous, more adaptable to local climatic zone and executable to achieve the basic provisions for sustainable development to ensure sustained availability of building resources through regeneration and/or reuse/recycle.
- e) encouraging use of traditional materials, technologies, vernacular design and construction practices, which have stood the test of time and which may be blended with the modern technology applications.

3.5 Energy Efficient Design and Processes

All efforts need to be made towards optimum and efficient use of energy sources for life sustenance. The increasing thrust on using non-fossil fuel energy for all needs have to be given priority consideration. The tapping of renewable sources of energy for lighting, heating, cooling and ventilation needs, deserve special attention. For example, an improved day light factor will reduce the day lighting needs by means of

supplementary lighting with added health benefits such as reduced eye strain (associated with constant elimination conditions). India with over 95 percent of the clear design sky available, the design has to fully utilize the associated benefits. While deciding on the energy choices, life cycle cost analysis including tangible and intangible benefits should be made and not look at the onetime initial capital expenditure alone. The end of life options should also be perceived.

3.6 Reduced Embodied and Operational Energy

All designs, materials and technologies, construction practices should be selected and employed, aimed at reducing the overall embodied and operational energy involved in construction and operation of the built facility. The construction should promote sustainability through adoption of local resources (natural and man-made) and skills.

3.7 Integrated Water Management

Considering an ever increasing demand for water for a growing population, efforts are needed to substantially reduce per capita water consumption in buildings. Integrated and sustainable water management focusing on least anthropogenic water discharge from human activities should be pursued. The use of water conserving fixtures, landscaping, rainwater harvesting, aquifer recharging and waste water recycling need to be given due priority consideration.

3.8 Operation and Maintenance of Services

This should involve use of efficient building and plumbing services components and fixtures tailor-made to meet sustainability objectives and creating sufficient awareness among the users of building facility and its services, during the occupancy stage.

3.9 Monitoring Compliances

The measures adopted during design, construction and occupancy stages should be monitored against norms as per this Code at periodic time interval to ensure sustainability.

3.10 Corporate Governance

The concerned top management should ensure association of all stakeholders including the training and awareness in pursuing and achieving needs for sustainable development at all stages of building lifecycle (from design to end of life). The environmental impact assessment should be carried out and remedial measures based on the findings should be taken during the life cycle of the buildings.

3.11 Disaster Preparedness

3.11.1 General

Disaster preparedness as part of approach to sustainability is in addition to the normal considerations of structural safety, health safety, fire safety and public safety taken into account in the building planning, design, construction, use and occupancy, and end of life. The disasters may be natural disasters such as earthquake, floods, cyclone, tsunami, landslides and avalanches; and man-made disasters such as nuclear, chemical, and biological disasters, explosions, act of sabotage and terrorism. Consequence of such disasters could be life threatening and debilitating in the long run.

Also man-made or natural disasters can trigger combined form of progressive disasters. The severity index is another important factor which will be governed by geomorphology, wind flows and cyclonic vulnerability, and climatic zone wherein the construction is proposed. *See* Part 6 ‘Structural Design’ of the Code for structural design of buildings for various loads, forces and effects using various building material options and structure systems.

3.11.2 Approach

The approach to disaster mitigation and management should be holistic and integrated with emphasis on prevention, mitigation and preparedness rather than being relief centric. The approach should emphasize on preparedness through planning, protection, training and partnership measures with associated stakeholders.

These efforts are aimed to protect and conserve existing development and also to minimise losses to lives, livelihood and property with clear cut focus on protection of environment. The approach shall be towards integrating disaster management as a part of design development, construction practices and management, operation and maintenance and end of life strategies. The required awareness should be achieved through multi stakeholder based planning, awareness, displays, mock drills and adequate training to both aged and young.

The disaster mitigation should also comprise identification of risks during construction, risks during occupancy stages/operations and preparing disaster preparedness plan by decommissioning. The occupancy type, density of occupancy and any specific/strategic aspects should be considered while working out disaster preparedness plan to achieve minimum damages and/or losses to lives, livelihood, properties and environment for the sustainable buildings for least damages or losses.

3.11.3 Disaster Risk Assessment and Mitigation

The formulation of disaster preparedness plan for any location should comprise the following steps:

- a) *Step 1* — Identify the geomorphology; river, coastal and cyclonic proximity; and climatic zone related disasters risks.
- b) *Step 2* — Identify population, business related disasters and vulnerabilities.
- c) *Step 3* — Carry out risk assessment through hazard analysis and vulnerability analysis including possible combining effects of multiple hazards. Also include the effect on micro-climate and environment biodiversity. Coastal zones which are falling in high cyclonic flood zone, tsunami, and seismic zones of high intensity and landslide sensitive areas should receive special attention.
- d) *Step 4* — Identify the socio-economic, socio-political hazards and vulnerabilities attributed to man-made disasters.
- e) *Step 5* — Prepare a disaster risk mitigation plan supported with sufficient budgetary provisions.
- f) *Step 6* — The disaster resistant building construction and infrastructure development features shall form part of the submittal to the Authority for statutory approvals.
- g) *Step 7* — Establish/nominate a responsible senior person/safety officer as controller for regulating, planning and monitoring disaster preparedness plan for whole project. Carry out all constructions, installations and operations in line with the disaster resistant features for each of the vulnerabilities.
- h) *Step 8* — Prepare and have mock drills at regular intervals for creating awareness and response preparation amongst stakeholder involved.
- j) *Step 9* — Prepare operation manual for post-construction operation and up keep of disaster resistant features and equipment.

The basic action plan should focus on capacity building amongst stakeholders involved, communication, co-ordination, role of information technology, role of every individual working at site and role of emergency response cell of building in conjunction with the mitigation plans of local/state level authorities. The possible after-effects on human and natural habitats and mitigation plan should form integral part of disaster preparedness plan for least damage to human life, built environment and related ecosystems.

4 APPLICABILITY OF THIS PART

4.1 Where a building is erected, this Part of the Code shall be applicable to such building.

In case of renovation or addition and/or alteration to an existing building, this Part of the Code shall apply to such parts of the building. However, owner shall have opportunity to get an existing building or part thereof evaluated under the provisions of this Part of the Code.

4.2 This Part of the Code may also be applied to the development projects.

5 IMPLEMENTATION OF THIS PART

Provisions for building planning, design including material selection and structural design, construction, operation and maintenance have been covered in National Building Code of India: Part 0 to Part 10. These also allow various options to be exercised, for example while various building materials have been listed therein along with their quality requirements for compliance, the choice may rest with the owner/building professionals, say for walling or masonry units, the options could be: use of common burnt clay bricks, perforated clay bricks, hollow clay bricks, fly ash lime bricks, fly ash clay bricks, calcium silicate bricks, solid/hollow concrete blocks, light weight concrete blocks, autoclaved aerated concrete blocks, preformed foam concrete blocks or any other alternative specified. This Part of the Code discusses such options from sustainability point of view for guiding in their appropriate selection. Similar explanation applies to other materials as also other aspects in planning, design, construction, operation and maintenance. However, once a choice of material, design methodology, construction technique/methodology, operation and maintenance related options, etc, is made, the provisions given in this Part of the Code for the same shall be complied with. This Part also prescribes provisions to be necessarily complied with so as to help achieve the objective of sustainability.

This Part should, therefore, be implemented in light of the above while following the approach given in 3. The Authority may require submission and verification of relevant documents while applying for building permit, to demonstrate compliance to the requirements of various provisions under this Part.

6 SITING, FORM AND DESIGN

6.1 General

Before initiating the formal design process, it is critical to evaluate all the passive design options to take advantage of local site and climatic conditions,

acceptable thermal comfort conditions and other occupant requirements. Passive techniques are very cost effective, climate responsive and energy efficient and help a building integrate better with its immediate environment and most importantly do not create any negative impact on the environment unlike active systems that may cause various negative impacts including ozone depletion, global warming and environmental disruptions. The objective, therefore, is to encourage passive design strategies for every building as a means to reducing overall energy demand before pursuing active and mechanical means in an effort to not only save energy but also to minimise the overall negative impact on the environment.

The requirements for the development of buildings and building sites that encourages sustainable building practices including siting, form and architectural approach towards sustainable development, are given in 6.2. The purpose includes providing guidelines that establish objectives for siting and form of residential, mercantile, industrial or other building occupancy developments early in the design stage so as to address sustainability through design. These objectives include, but are not limited to, energy conservation, water conservation and reduced greenhouse gas emissions.

6.2 Site Design and Development

6.2.1 Site Assessment Prior to Design

The responsible design professional shall prepare an assessment of the onsite natural resources and pre-site conditions. The person shall,

- a) establish, if there are any protected areas such as floodplains; forest department areas; water bodies such as sea, lakes, rivers, wetlands, tributaries and/or streams; coastal regulation protected areas; defence areas; public parks and recreation areas (unless otherwise used for the purpose of the park); natural contours/terrain requiring protection and agricultural land (unless serving an agriculturally related purpose such as storage, processing, transport, etc) and demonstrate that no critical natural resource is impacted by the project and/or dredging operations;
- b) establish the degree to which the existing soil at site and hydrology has been disturbed prior to development and demonstrate various site erosion protection measures taken including measures to preserve natural stormwater drainage system, top soil and existing vegetation, minimise soil disturbance as specified in Part 10 'Landscape Development, Signs and Outdoor Display Structures

Section 1 Landscape Planning, Design and Development' of the Code;

- c) identify and ensure diversion, avoidance of existing water, power, communication, sewerage lines, saving/replanting of old trees, removal of existing invasive vegetation on site and that no invasive vegetation is planted post completion; and
- d) identify and ascertain the natural resources available onsite and surrounding areas and ensure optimum utilization of the same in construction and post occupancy.

A site assessment report for the building/development project shall be prepared.

6.2.2 Building Form, Orientation and Shading

The development shall plan on locating, orienting and shading the building so that,

- a) there is adequate provision for external shading of the facades during the peak summer season;
- b) there is adequate provision for vertical shading to prevent direct solar radiation and glare due to low altitude sun angles, specifically on the eastern and western facades;
- c) the building is oriented optimally based on sun-path and engineering analysis; and
- d) there is adequate protection for the building envelope against thermal losses, drafts and degradation by natural elements such as wind, dust, sand, snow, rainwater, hail, etc.

The above strategies shall be implemented based on the climatic conditions of the location. Specifically, the designs should be based on the heating degree days and cooling degree days of the actual location of the building. In the absence of this data, a more generalist approach based on the five climatic zones of the country may be used.

The responsible design professional shall carry out building orientation and shading studies and establish the optimal building orientation for the project and ensure appropriate shading design such that the facades are shaded for more than 50 percent of the summer solstice. A solar path analysis shall be done as an aid in arriving at optimum form and orientation for the building. Appropriate shading design can be arrived at either through simulation approach or by using the prescriptive shading norms as indicated in the SP 41 : 1987 'Handbook on the Functional Requirements of Buildings (other than industrial buildings)'. A design report showing both the optimum orientation and shading design strategies along with justification for the selection of the same shall be prepared.

6.2.3 Thermal Massing

The responsible design professional shall carry out building thermal massing studies to evaluate the impact on thermal mass on the consequent thermal transmittance and energy performance of the building based on the sun-path analysis and local/equivalent weather data. A report showing both the optimal thermal massing and the choice and justification of the proposed wall material of the building together with the design approach for decision making shall be prepared, together with other documents while applying for the building permit.

6.2.4 Reduced Building Footprint in Multi-Storeyed Building Designs

The requirements for open spaces (within a plot) as specified in 8 of Part 3 'Development Control Rules and General Building Requirements' of the Code shall be complied with. In any case, at least 30 percent of the open spaces shall be maintained as softscapes (permeable surface on ground). For areas where the calculated softscape area requirement is less than 10 percent of the total plot area, a minimum of 10 percent softscape area shall be provided.

6.2.5 Optimum Building Volume

For air conditioned buildings, efforts shall be made in design to reduce building volume by reducing floor to floor and floor to ceiling height without compromising the utility and functional efficiency of the building. For natural ventilated buildings or mixed mode ventilated building, the optimum building volume and floor to floor heights to be ascertained and a report on the design and justification of the same shall be prepared.

6.2.6 Building Form Development Plan

A report shall be prepared on the evolution of the form of the building based on science of architecture, climatology and building physics. The plan shall be in line with the decision making process of the project team and a narrative shall be prepared briefly mentioning the justification behind the selected building form and orientation of the building and shading devices to ensure that the final design meets with the intent of this Part.

6.2.7 Natural Ventilation, Cooling and Wind Effects

A report illustrating the evaluation of the various natural ventilation and cooling studies to maximize natural ventilation or mixed mode ventilation based on adaptive thermal comfort criteria for the project, shall be prepared. In addition, for high rise buildings, wind analysis shall be carried out to evaluate the impact of wind movement and natural air flow changes because of the new building proposed to be erected. Strategies

may include application of cross-ventilation and thermal comfort, factoring prevalent wind patterns, seasonality, stack effect and other principles. A narrative on how these aspects have been factored in the design shall be prepared.

6.2.8 Optimal Daylighting

A day lighting analysis study based on the proposed form of the building for the project shall be carried out and a report thereof prepared. It shall be demonstrated that at least 25 percent of the regularly occupied areas of the building achieve sufficient day lighting with a minimum day lighting factor of 2 percent or as described in SP 41:1987 'Handbook on the Functional Requirements of Buildings (Other than Industrial Building)'. For details of day lighting harvesting methods and calculations (see 8.1.3.2).

6.2.9 Defining Building Service Life in Terms of Minimum Component Service Life

A building service life plan shall be prepared along with the design and construction documents. The plan shall clearly indicate the design service life and the minimum design service life shall be not less than 60 years for the structure itself and not less than 10 years for various service components, equipment and systems within the building. All plan shall include dismantling, de-mounting and re-use plan.

6.2.10 Life Cycle Assessment (Optional)

The materials and assemblies may be selected based on their carbon footprint (GHG emission potentials) and/or a life cycle assessment of the embodied energy of the product. For more details on LCA analysis of building materials (see 9.1.4).

7 EXTERNAL DEVELOPMENT AND LANDSCAPE

7.1 Landscape Planning and Design

The landscape planning and design shall be in accordance with Part 10 'Landscape Development, Signs and Outdoor Display Structures, Section 1 Landscape Planning, Design and Development' of the Code. In addition, the provisions given in 7.1.1 to 7.1.3 shall be followed.

7.1.1 Landscape Design

Proper landscaping helps in maintaining natural capacity of site for stormwater management, filtration, groundwater recharge and maintenance of soil structure thereby contributing to soil organic matter, and preventing erosion. It helps in moderating microclimate through evaporation, transpiration and the uptake and storage of carbon in trees and other vegetation.

7.1.1.1 *Microclimatic conditions*

Microclimatic conditions play an important role in landscape design and in working out irrigation requirements, as it accounts for the environmental conditions specific to the landscape, including temperature, wind and humidity. For example, a water body can increase the humidity and a wind funnel can increase the evapotranspiration rate and hence the irrigation requirement. The microclimatic conditions may be taken into account in landscape irrigation calculations by applying a microclimate factor.

The average microclimate factor is 1.0 and this refers to conditions where the landscape evapotranspiration rate is unaffected by buildings, pavements, reflective surfaces and slopes. Higher microclimate factor conditions occur where evaporative potential is increased due to landscapes surrounded by heat absorbing and reflective surfaces or due to exposure to particularly windy conditions. Examples of high microclimate factor areas include parking lots, west sides of buildings, west and south sides of slopes, medians, and areas experiencing wind funnel effects. Areas with low microclimate factor include shaded areas and areas protected from wind. North sides of buildings, courtyards, areas under wide building overhangs and north sides of slopes.

7.1.1.2 *External noise reduction/mitigation practices*

Need for reducing the noise at site shall be assessed. If so required, appropriate measures may be taken for noise abatement, such as quieter pavement or road surfacing, dense foliage, earth berms, barriers or screens, and scheduling maintenance activities when site users are not present. Walls, fences and vegetation may also be used to break, guide, deflect or filter the wind and thereby alter its effects. Noise may be reduced with use broad-leaved trees more than with the conifers and this further improves when foliage extends close to the ground. The best location for a noise barrier is either very close to the source or very close to the receiver while the worst position for attenuation is halfway between them. Provisions of Part 8 'Building Services, Section 4 Acoustics, Sound Insulation and Noise Control' of the Code shall be followed.

7.1.1.3 *Building shadow considerations on landscape*

Vegetation provides climate moderating benefits as well as benefits to human health. Most vegetation requires sunlight in varying degrees for their growth and maintenance. The buildings by their design, shade certain parts of the external areas for some part of the day or other. External landscapes shall be designed taking the shading pattern of the buildings into consideration. For instance the northern side external areas of the building tend to be shaded for large parts

of the day, while the southern side has access to sunlight for most times of the day, the choice of vegetation should be based on the availability of sunlight along different solar exposures and the requirement of various species of vegetation. Vegetation also has the potential to reduce the energy consumption of a building by providing shading and a cool microclimate. Vegetation and/or vegetated structures shall be kept in strategic locations around buildings to reduce energy consumption and costs associated with indoor climate control.

7.1.2 *Hard Landscape Design*

7.1.2.1 *Pervious paving design*

Pervious paving helps in holding rainwater, reducing the rate of storm water flow, infiltrating storm water into the ground for reuse and also helps in filtering the rainwater. Besides helping in storm water management, pervious paving helps in reducing the heat island effect. For sustainable site planning, perviousness in the paved areas of the site may be maximized.

However, the rainwater harvesting potential of pervious paving is subject to local geo-morphological formations and the use of the same should be assessed based on local conditions. For example, in coastal areas, where the water table may be high and the water absorptive capacity is low, pervious paving may not be as effective.

7.1.2.2 *Heat island effect and parking design*

The heat island effect raises the localized temperature, impacting local climate/microclimate. Plants and animals that are sensitive to large fluctuations in day time and night time temperatures may not thrive in areas affected by heat island. Heat islands also exacerbate air pollution as smog is produced faster at higher temperatures and as rising temperatures lead to increased cooling requirements, requiring energy and causing associated emissions.

Open parking areas consisting of concrete and asphalt absorb heat and contribute substantially to the heat island effect. Shading and/or use of light-coloured/high-albedo materials and/or open grid pavement for the site's non-roof impervious surfaces, including parking lots, walkways, plazas, etc, shall be made to help in reducing the heat island effect.

The solar energy should instead be utilized for generation of renewable energy, thus serving the dual purpose of dampening the heat island effect and reduction in use of fossil fuel for energy generation (see 11.16).

7.1.2.3 *Post-occupancy maintenance*

A site maintenance plan shall be developed that outlines the long term strategies and identifies short-term actions

to achieve sustainable maintenance goals. The plan should address issues such as plant maintenance, integrated pest management, soil management, fertilizer use, rainwater harvesting, reducing freshwater consumption, site safety, and irrigation allotment and schedule.

7.1.3 Soft Landscape Design

7.1.3.1 Preserving top soil

Healthy soils allow rainwater to penetrate, preventing excess runoff, sedimentation, erosion, and flooding. Soils also help clean and store water, and recharge groundwater. By storing water and slowing the delivery of water to plants, healthy soils play a significant role in vegetation health. In areas of previously disturbed soils, soil function shall be restored to rebuild ability of soils to support healthy plants, biological communities, and water storage and infiltration. In existing soils, depending upon the requirement, the need of soil compaction, organic matter levels, and the balance of soil organisms shall be addressed. It shall be ensured that adequate soil volume is made available for proper plant growth. In order to protect soil horizons and maintain soil structure, existing hydrology, organic matter, and nutrients stored in soils, the disturbance to healthy soil shall be limited. Typically, the first 200 mm soil depth is most conducive for plant growth, and is considered as top soil. Where healthy top soil is being disturbed due to construction activities like excavation, the top soil should be stripped and stacked on one side till further use. Use of excessive chemicals such as fertilizers may result in lasting damage to the soil ecology and shall, therefore, be avoided. *See* Part 10 ‘Landscape Development, Signs and Outdoor Display Structures, Section 1 Landscape Planning, Design and Development’ of the Code, for further details regarding protection of landscape during construction.

7.1.3.2 Ecological design/conserving biodiversity

A diverse range of species, especially native plants can provide habitat for native fauna, including important pollinator species (for example, insects, birds and bats) that are necessary for plant reproduction, including cultivation of crops. Also, biodiversity in landscapes helps in retaining soil nutrients and is more resistant to attacks by pests. The following considerations shall be used:

- a) *Protection and use of existing vegetation* — Such sites shall be selected that do not include habitat for threatened or endangered species. Site may be designed to minimise disruption to existing habitats. Trees designated as important by concerned local, state or central authorities shall be preserved. Mature trees are significant community resources because

of their cultural, aesthetic, or historic relevance and shall be preserved. Transplantation for mature trees within the site or to another site shall be explored, where vegetation clearing is necessary for construction.

- b) *Use of vegetation that promotes a regional identity and a sense of place* — Native plants which are endemic to the location and appropriate non-native plants adapted to site conditions, climate, and design which support biodiversity, reduced pesticide use and water conservation, shall be used. Only non-invasive plants that are nursery grown, legally harvested or salvaged for reuse from on or off-site shall be used.
- c) *Conservation of native endangered species* — Native vegetation that is endangered in the locality may be planted to conserve/enhance the gene pool of native vegetation and promote biodiversity.

7.1.3.3 Landscape design for controlling solar gain

Vegetation placed in strategic locations around buildings provides an opportunity to reduce energy consumption and costs associated with indoor climate control for cooling. Trees, shaded trellises, green roofs, green facades and green walls may be used individually or in conjunction with other measures to increase shading both on the ground and on the building surface. Deciduous trees allow access to the sun in winter and provide shade in summer. Vegetation provides significant opportunities in conserving building energy consumption, especially if the west, south-west, south-east and east facades of the building are shaded. For buildings with natural ventilation, the vegetation species shall be carefully chosen such that they provide shade, but do not significantly block cool breezes or any convective air currents.

7.1.3.4 Vertical landscaping and roof gardens

Roof garden and/or green walls or vertical landscaping may be provided as it helps in conserving energy by providing shading, reduces heat island effect, helps (specially in dense areas) in maintaining a certain biomass critical for human health and also helps in reducing storm water flow rates through bio-retention. Required caution shall be observed in respect of water proofing requirement for the above.

7.1.3.5 Urban agricultural practices/social forestry

Growth of cities puts a significant pressure on natural resources resulting in drastic reduction of green open spaces, depletion of trees, heat island effects, and floods and other natural disasters, further aggravated by the effects of climate change. Proper attention may be given

to the potentials of urban forestry and agriculture for contributing towards urban greening, heat reduction, storage of excess storm water and maintaining flood plains free from construction. Large scale developments that exceed 10 hectare should be encouraged to fulfil minimum 5 percent bio-capacity required to sustain themselves.

7.2 Rainwater Harvesting — Surface Runoff

7.2.1 Rainwater Harvesting

Rainwater harvesting refers to collection and storage of rainwater and also other activities aimed at harvesting surface and groundwater, prevention of losses through evaporation and seepage and all other hydrological studies and engineering interventions, aimed at conservation and efficient utilization of the limited water endowment of physiographic unit such as watershed. In general, rainwater harvesting is the activity of direct collection of rainwater. The rainwater collected can be stored for direct use or can be recharged into the groundwater. While enough measures should be taken voluntarily, the Authority should encourage and appropriately provide for ensuring rainwater harvesting in outdoor built environment.

The system of collection of rainwater and its conservation for future needs has traditionally been practiced in the country, such as through *Baoris*, step wells, lakes, tanks, roof top collection systems, etc, to meet the domestic and irrigation demands. This also helps to arrest groundwater decline and augment groundwater table, beneficate water quality in aquifers, conserve surface water runoff during monsoon, reduce soil erosion and inculcate a culture of water conservation.

Two broad approaches to rainwater harvesting are:

- a) *Storing rainwater for direct use* — Under this approach, for domestic and irrigation purposes, the rainwater is directly collected either in the natural or man-made structures such as *Nadi*, *Tanka*, *Kund*, sand filter bed, pond, rooftop rainwater collection structure, etc.

Roof rainwater collection system augments the water demands by collecting rainwater from the roof and diverting it to specially designed storage or recharge tanks, as per the requirement. On sloping roofs, evaporation losses are small, so collection efficiency may be of the order of 85 percent. Rainwater may be collected from any kind of roof. Tiled or metal roofs are easier to use for the purpose and a smooth surface for the roof will help in water flow and collection.

To reduce contamination of rooftop rainwater, the necessary actions and precautions as given below shall be followed:

- 1) Avoid overhanging of trees above the roof to prevent leaves and bird droppings falling on the roof.
 - 2) Do not allow the first rainfall to enter the tank by diverting it away from tank; although human or animal coliforms are not involved, bird droppings or lizard faeces, and other air borne dirt are also to be washed away from the roof.
 - 3) Filter the water on entering the tank by suitable filter and also cleaning the filter and tank regularly.
 - 4) Seal tanks to keep out sunlight (to prevent algae growth), mosquitoes, lizards, birds, etc.
 - 5) Disinfect tanks once in a year with bleaching powder.
- b) *Recharging groundwater aquifers* — This approach involves use of various kinds of recharge structures, which not only arrest the water but also promote water percolation through soil strata to recharge the depleting aquifers. Structures like percolation tank, anicut, gabion, etc, facilitate the recharge of underground aquifers. However, meteorological and hydrological investigations along with geo-technical investigations shall be carried out before selecting the best suited method for groundwater recharge. Direct injection of rainwater through deep bore wells should be avoided for quality control reasons.

For rainwater harvesting a reference to 4.5.12 of Part 9 ‘Plumbing Services, Section 2 Drainage and Sanitation’ of the Code may be made. For further details, reference may also made to good practice [11(1)].

7.3 Water Elements and Irrigation Practices

7.3.1 Design and Post Occupancy Maintenance of Water Features

The site maintenance plan (*see 7.1.2.3*) shall include appropriate maintenance activities for the water features taking care of the following considerations:

- a) Use of chemicals likely to harm aquatic life, such as chlorine and bromine shall be avoided.
- b) Maintenance activities to ensure that the water features do not create habitat for mosquitoes, shall be included.
- c) Water features shall be designed such that they match or mimic water in the natural

environment; and water features that are incompatible with the local ecological context (for example, a lake in a desert) shall be avoided.

- d) Volumes of rainwater or water from other non-potable sources available on site for use in water features shall be estimated, and water features shall be so designed that these are integrated with the site so as to utilize this water on site, and not require additional water from potable water sources.
- e) Non-potable water from sources such as gray water, reclaimed water or storm-water basins shall be collected and used for non-potable applications.
- f) Design and maintain water features as natural ecosystems with water source(s), plants and aquatic organisms appropriate for local conditions.
- g) Water quality may be enhanced in created water features with biologically-based water treatment including with the use of certain enzymes, mineral, and oxygen-based additives, especially during initial establishment.
- h) Natural swimming pools or other water features intended for human contact may require additional treatment methods such as ozonation or thermal treatment.

7.3.2 Water Conservation and Irrigation Practices

Selecting efficient irrigation systems, planting vegetation appropriate for site conditions and climate, and using captured rainwater or gray-water can reduce water waste and conserve sources of potable water. Typically, half of irrigation water may get wasted as a result of evaporation, wind, improper system design, and over-watering requiring the following considerations which may be followed:

- a) Low water demand vegetation (xeriscape) and high-efficiency equipment (for example, drip irrigation) and/or climate based controllers for irrigation systems should be used.
- b) If turf grasses are to be used, they should be selected, to be regionally appropriate and to minimise post-establishment requirements for irrigation. The turf area should not exceed 30 percent of the total landscaped area.
- c) Reuse gray-water, captured rainwater and/or condensate water for irrigation to decrease potable water use for irrigation as well as to create a net benefit to the local watershed by making the landscape part of the natural water-treatment process.

- d) If gray-water or wastewater is to be recycled for landscape irrigation, tests should be conducted to determine suitability for reuse.
- e) Irrigation systems should be so designed that trees, shrubs and ground cover are irrigated in separate hydrazones such that watering can be discontinued zone by zone as plants become established.
- f) A sub-surface drainage system shall be planned in areas covered with turf to collect excess water for reuse.

7.4 External Access Design

7.4.1 Reduced Environmental Impacts from Parking Facilities

Open parking areas, if largely made of concrete and asphalt, absorb heat and contribute substantially to the heat island effect. This shall be mitigated by following the considerations given below:

- a) Rendering these areas white or light in colour instead of black, so that they may reflect a lot of sunlight back to space rather than absorbing it.
- b) Providing shade and/or using light-coloured/high-albedo materials and/or open grid pavement for the site's non-roof impervious surfaces, including parking lots, walkways, plazas, etc.
- c) Limiting the net paved area of the site under parking, roads, paths, or any other use so as not to exceed 25 percent of the site area or net imperviousness of the site not to exceed the imperviousness factor as prescribed in 4.5.11.2.1 of Part 9 'Plumbing Services, Section 2 Drainage and Sanitation' of the Code, whichever is more stringent.

Additionally, the following shall be complied with:

- 1) More than 50 percent of the total paved area shall have pervious paving/open grid pavement/grass pavers, or
- 2) A minimum 50 percent of the total paved area (including parking) shall have shading by vegetated roof/pergola with planters, or
- 3) A minimum 50 percent of the total impervious paving area (including parking) shall be topped with finish having solar reflectance of 0.5 or higher.

The external access, including pedestrian walkways/pathways shall be designed and developed in accordance with Part 3 'Development Control Rules and General Building Requirements' of the Code.

7.4.2 Long term Public and Private Transportation Plan

The long term public and private transportation plan shall take care of the following considerations:

- a) Incorporating urban transportation as an important parameter at the urban planning stage rather than being a consequential requirement;
- b) Encouraging integrated land use and transport planning in cities so that travel distances are minimised and access to livelihoods, education, and other social needs, especially for the marginal segments of the urban population is improved;
- c) Improving access of business to markets and the various factors of production;
- d) Bringing about a more equitable allocation of road space with people, rather than vehicles, as its main focus;
- e) Encouraging greater use of public transport and non-motorized modes;
- f) Enabling the establishment of quality focussed multi-modal public transport systems that are well integrated, providing seamless travel across modes;
- g) Establishing enforcement mechanisms to ensure efficiency and enhanced safety for the transport system users;
- h) Establishing institutional mechanisms for enhanced coordination in the planning and management of transport systems;
- j) Introducing intelligent transport systems for traffic management;
- k) Addressing concerns of road safety and trauma response;
- m) Reducing pollution levels through appropriate travelling practices, better enforcement, stricter norms, technological improvements, use of electrically operated vehicles etc; and
- n) Building capacity (institutional and manpower) to plan for sustainable urban transport and establishing knowledge management system.

7.4.3 Bicycle Lanes and Pedestrian Access — Safety and Comfort

Construction of cycle tracks and pedestrian paths in cities enhances safety and thereby enhances use of non-motorized modes. The safety concern of cyclists and pedestrians should be addressed by encouraging the construction of segregated rights of way for bicycles and pedestrians. Apart from improving safety, the segregation of vehicles moving at different speeds helps

improve traffic flow, increase the average speed of traffic and reduce emissions resulting from sub-optimal speeds. Such segregated paths are useful not only along arterials, to enable full trips using non motorist transport but also as a means of improving access to major public transport stations. Such access paths, coupled with safe bicycle parking places, may be provided for promoting an increased use of public transport. Creative facilities like shade giving landscaping, provision of drinking water and resting stations along bicycle corridors should also be encouraged to help mitigate, the effect due to adverse weather conditions. The use of the central verge along many roads, along with innovatively designed road crossings, may be considered for developing as cycle tracks. At busy intersections and high traffic corridors, pedestrian crossing shall be constructed.

Following are some of the features which should be considered while designing pedestrian and cycle/cycle-rickshaw friendly environment:

- a) Design and construction ensuring safety and comfort of all the users.
- b) Use of following climatic design features for streets and public spaces to make them comfortable for pedestrians, cyclists and public transport users, based on local climate:
 - 1) Planting of deciduous trees all along the pedestrian/cycling path to provide adequate shade in summer and allow solar access in winter.
 - 2) Considerations to overhangs, arcades and closely built buildings providing shading and comfort in summer to the public realm.
 - 3) Orientation of streets to allow the desirable directional wind flow through streets and public spaces in summer and block undesirable winds in winter, to ensure comfort in the public use areas.
- c) Signalization of junctions and mid-block crossings on roads to allow safe crossings at grade.
- d) Multimodal interchange and provision of good para-transport options and walkability at the neighbourhood level as the most important factor in reducing use of private modes and also reducing transportation demand; and the following to be provided so that people can walk or cycle easily for short trips as well as for accessing mass transport stations:
 - 1) Fast and convenient interchange between modes (distances between modal changes to be as per multimodal integration and connectivity requirements).
 - 2) Closest convenient interchange access at

- stations for pedestrians, non-motorized modes and public/paratransport modes, preferably within 50 m of station exits.
- e) Proper street grid density as a critical requirement in urban design to ensure small blocks and an interconnected street network to provide a walkable, public transport friendly neighbourhood as per the following:
 - 1) Street grid density of 7-10 km centre-to-centre/km² for residential-mixed use neighbourhoods and 13-20 km centre-to-centre/km² for commercial-mixed use neighbourhoods to provide adequate connectivity and frequent directional changes for pedestrians.
 - 2) Direct and shortest route/access to station through provision of cut-throughs for pedestrians and non-motorized transport through blocks above 200 m in length with a view to making smaller block sizes.
 - 3) Signalization of junctions and mid-block crossings on roads to allow safe crossings at grade at a maximum frequency of 200 m.
 - f) Provisions of dedicated lanes and signal prioritization for pedestrians, non-motorized transport and public transport on major corridors so as to provide priority and congestion-free movement for these modes.
 - g) Adequate street lighting for pedestrians and bicycles to ensure their safety; minimum illuminance being 30 lux for non-shopping areas and 20 lux for shopping areas, bus stops and signalized crossings.
 - h) Commercial/hawking zones at regular intervals in accordance with the local byelaws/masterplan (within 5 min walk from every home in the city) to encourage walkability and increased street activity and to provide safety.
 - j) Amenities for public transport users:
 - 1) Amenities at-grade crosswalks (and overpasses on highways) at intervals of 80-200 m, aligning with location of transit stops, type of street/land use activities and neighbouring building entries and destinations.
 - 2) Dustbins, letter-boxes, signages and other public amenities at street corners for high usability.
 - 3) Accessible public toilets at every 500 m to 800 m distance, preferably located close to bus stops for easy access by pedestrians and public transport users.

- k) Barrier free environment to make public streets and crosswalks fully navigable by all persons including the persons with disability and the elderly.
- m) Vertical mixing of uses such that all non-work trips are reduced to be under 500 m walking distance such that vehicular trips may be eliminated for daily errands; for example through mixed convenient/community shopping uses with residential uses to reduce dependency on private vehicle and shifting all short trips from private vehicle to walking, cycle-rickshaw or public transport.

7.4.4 Off Street Parking

The off street parking shall be planned taking care of the following objectives as per Part 3 'Development Control Rules and General Building Requirements' of the Code:

- a) To relieve congestion on streets by providing convenient off-street parking and loading facilities in proportion to the demand created by the use;
- b) To provide for the safe and orderly movement of traffic through proper design and location of adequate parking, loading, and manoeuvring areas;
- c) To protect neighbourhoods and surrounding land uses from vehicular parking, loading and traffic congestion, noise and dust, through proper aesthetic design and location of entries, parking areas, and landscaping;
- d) To promote businesses, industries and commercial activities by providing safe, convenient, attractive parking facilities and environments; and
- e) To encourage the use of efficient forms of transportation.

7.4.5 Discouraging Subsidized Parking in Public Realm

Subsidized parking in public roads and spaces, especially in urban areas with high traffic density or having likely projected high traffic density should be discouraged to reduce private vehicle usage and inducing a modal shift towards public transport. Parking management may be used as a demand management tool rather than a supply based tool, with the following considerations:

- a) Discouragement to the use of car as a feeder or a general mode of transport, with park and ride facilities being only at stations of mass rapid transport system (MRTS).
- b) Providing parking only for servicing rather

than for access, and only emergency vehicle access to be provided which can be done through provision of mountable kerbs, etc, on pedestrian dominated streets.

- c) No free or subsidized parking in public space and actual parking cost to be defined by market forces.
- d) Enforcement of parking caps in areas with mass rapid transport access.
- e) Park once-and-walk facilities in busy markets and residential/mixed use areas.
- f) Strict enforcement of parking through self-regulating design.

7.4.6 Providing Neighbourhood Connectivity, Walkability and Safety

At the site design and block design level, several measures should be taken for reducing transportation demand and promoting walkability, and ensuring that the neighbourhood is a safe walkable place. These measures should include the following:

- a) Vertical mixing of housing and community based uses to ensure vibrancy and safety.
- b) Based on local climate, minimum 2 h daylight access to neighbouring buildings to be ensured through provision of required street width-to-height ratios, in accordance with Part 3 'Development Control Rules and General Building Requirements' of the Code.
- c) *Block sizes and paseos* — For blocks where any one side is greater than 200 m in length, a public access cut-through for pedestrians and non-motorized transport (NMT) shall be provided. This ensures connectivity and walkability in the neighbourhood enabling short local trips to be made on foot.
- d) The setbacks and boundary wall for commercial properties should be designed so as to also promote safety and encourage pedestrian communication.

7.4.7 Ecology of Streets

As streets constitute about 20 to 25 percent of the impervious cover of the city, they have a large detrimental effect on the heat island effect and ecological character of a city. The following design components should be integrated in street design:

- a) Planting of trees as an essential component for all streets to provide shade to pedestrians and reduce solar gain.
- b) Use of high albedo (diffused reflectivity) materials for paving and increasing greenery around to reduce heat island effect.

- c) Decreasing impervious surfaces through permeable paving, tree planting zones, etc, to increase groundwater infiltration and prevent seasonal flooding.
- d) Integrate natural storm water filtration and absorption into street design through bio-filtration beds, bio-swales and detention ponds.

7.5 External Lighting Design

7.5.1 Landscape Lighting Design — Allowable Lighting Power Density (LPD)

Light pollution can disrupt circadian rhythms and melatonin production, which has been linked to serious health concerns. Reasonable use of outdoor lighting restores dark night skies and preserves the ambiance of the night. Whether outdoor light is directly adjacent to a species habitat or located at some distance is an important consideration, as through sky glow, the combined effects of artificial lighting on vast numbers of nocturnal species have the potential to disrupt the functioning of entire ecosystems by disturbing balances in competition and predation. The landscape lighting should be designed such that light fixtures emit minimum light as per the specified total fixed lumens and only light the areas as required for safety and comfort. In addition, the lighting shall be efficient complying with the requirements of maximum LPD given in Table 1.

7.5.2 External Signage Design

External signage may be designed to address the following main issues related to overall sustainability:

- a) The signage shall be classified as external lit and internal lit and further classified based on functional requirements such as emergency, way finding, etc. The requirements of each type of signage are different and should be evaluated based on the same. The recommended lighting power density is 130 W/m², maximum for internally illuminated signage, and 25 W/m², maximum for externally illuminated signage.
- b) Illuminated signage forms a substantial part of upward directed lighting. Efforts should be made to shield the lighting.
- c) Paints, adhesives, etc, used in the signage should be of low VOC.
- d) Fabrication of the signage should be using materials locally available and having a recycled content.

7.5.3 External Lighting

The facades may be lit with fixtures that are shielded,

Table 1 Maximum Lighting Power Densities for Building Exteriors

(Clauses 7.5.1 and 7.5.3)

SI No.	Area to be Lit	LPDs Max (3)
(1)	(2)	
i)	<i>Uncovered parking areas:</i>	
	a) Parking lots and drives	1.6 W/m ²
ii)	<i>Building grounds:</i>	
	a) Walkways less than 3 m wide	3.28 W/linear metre
	b) 1) Walkways 3 m wide or greater 2) Plaza areas 3) Special feature areas	2.15 W/m ²
	c) Stairways	10.76 W/m ²
iii)	<i>Building entrances and exits:</i>	
	a) Main entries	98.52 W/linear metre of door width
	b) Other doors	65.68 W/linear metre of door width
iv)	<i>Canopies and overhangs:</i>	
	a) Canopies (free standing and attached and overhangs)	13.45 W/m ²
v)	<i>Outdoor sales:</i>	
	a) Open areas (including vehicle sales lots)	5.38 W/m ²
	b) Street frontage for vehicle sales lots in addition to open areas allowance	65.68 W/linear metre
vi)	Building facades	2.15 W/m ² for each illuminated wall or surface or 16.42 W/linear metre for each illuminated wall or surface length
vii)	Automated teller machines (ATMs) and night depositories	270 W per location plus 90 W per additional ATM per location
viii)	Entrances and gatehouse inspection stations at guarded facilities	13.45 W/m ² of uncovered areas covered areas are included under the canopies and overhangs
ix)	Loading areas for law enforcement, fire, ambulance and other emergency service vehicles	5.38 W/m ² of uncovered areas covered areas are included in the canopies and overhangs
x)	Drive-up windows at fast food restaurants	400 W per drive-through
xi)	Parking near 24 h retail entrance	800 W per main entry
xii)	Landscaped areas, including individual house courtyards, terraces	2.15 W/m ²

with less than 10 percent lumens above 90° from the nadir (see Fig. 3) and the lighting power density of the facade lighting may be as given in Table 1.

7.5.4 Light Trespass Allowance

The light trespass allowance may vary for different site surroundings, and a light should also vary for different settings depending upon the requirements. The site settings may be kept as,

- a) *Dark* — For rural setting.
- b) *Low lighting setting* — For residential areas/sub-urban areas and townships.
- c) *Medium lighting setting* — For medium rise buildings, high rise buildings, commercial/office areas and high density for non-commercial area.
- d) *High lighting setting* — For malls, entertainment areas and city centre areas.

8 ENVELOPE OPTIMIZATION

8.1 Building Envelope

The building envelope acts as the interface between indoor and external climatic conditions. It potentially

regulates the building climatic response. The building envelope should be designed to conserve energy substantially. Well designed building envelope maximizes daylight, natural ventilation (access to fresh air) and views to the exterior, and enables to modulate solar heat gain and control/reduce noise. The building envelope may also be designed to integrate systems for renewable energy and rainwater harvesting. In general, the design strategies drawn from long experience in the country in its various climatic zones may be taken into account (see Annex A for guidance).

Building envelope components and their configuration largely determine the amount of heat gain or loss and wind that enters inside the building and extent of natural ventilation in the building. The primary components of building envelope which affect the performance of a building are,

- a) walls,
- b) roof (including skylights and clerestories),
- c) fenestration (openings with or without glazing),
- d) floor, and
- e) surface finishes.

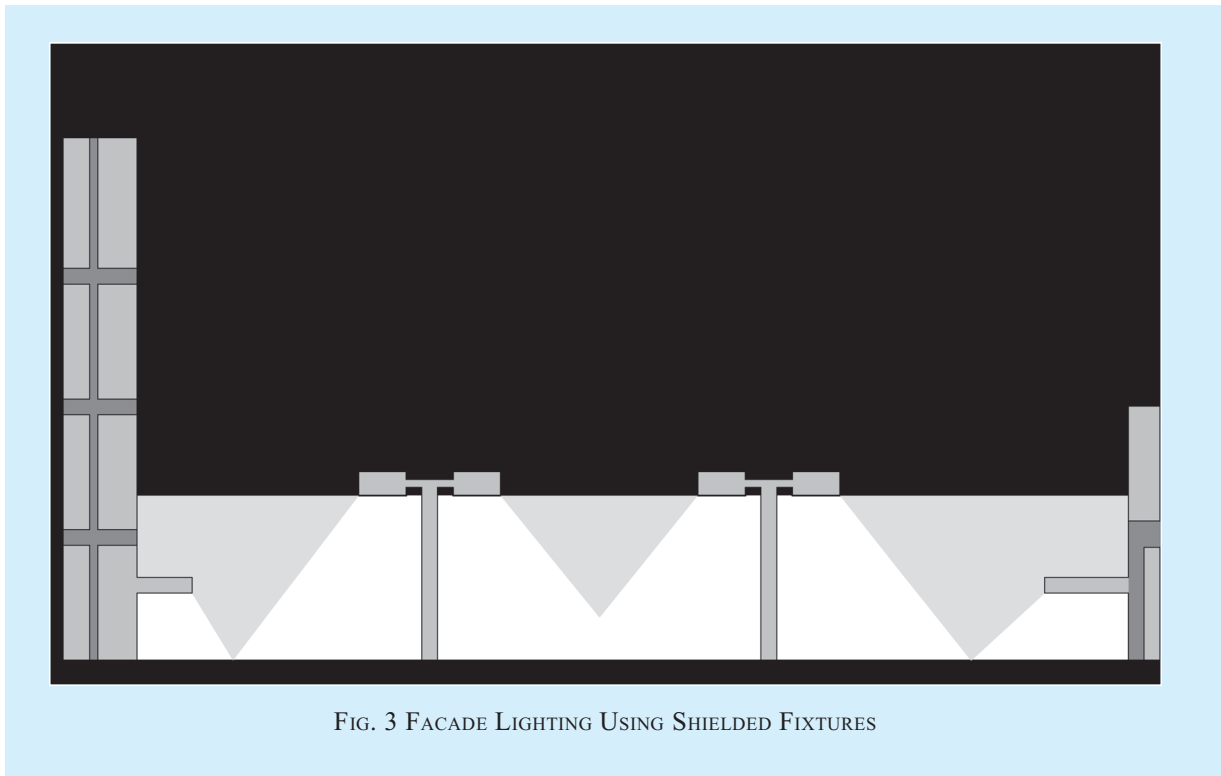

FIG. 3 FACADE LIGHTING USING SHIELDED FIXTURES

8.1.1 Walls

Walls are a major part of the building envelope, which are exposed to external environment conditions such as solar radiation, outside air temperature, wind and precipitation. The construction of wall and thereby its heat storing capacity and heat conduction property has a major impact on indoor thermal comfort in naturally ventilated buildings and on cooling loads in air conditioned buildings. The wall material, thickness, finishes should be selected according to climate zone and building's comfort requirement. Wall properties that determine heat transfer are thermal conductivity, thermal resistivity, thermal absorptivity, emissivity, thermal reflectivity and thermal capacity (*see 2*).

8.1.1.1 Enhancement of thermal performance of walls

Thermal performance of walls can be improved by following ways:

- a) *Thermal insulation (applying insulation on wall surface)* — Thermal insulation plays an important role in reducing the thermal conductance or U -value of walls. The effect of insulation is to reduce heat gain and heat loss. Insulation should always be placed on the hotter side of the surface. In hot climate zone, insulation should be placed on the external side of wall composition. Insulation also controls the interior mean radiant temperature (MRT) by isolating the interior surfaces from the impacts of exterior

conditions. Insulation along with infiltration control is important for reducing heating and cooling loads in simple occupancy (skin) load dominated buildings such as residences. In buildings, that are internal load dominated such as offices with high equipment load, the insulation thickness and properties should be determined based on thermal performance analysis including the role of insulation in reducing cooling energy consumption, particularly in hot and dry, composite and warm humid climates. Thermal insulation may be made from a variety of materials and in several forms. Broadly they may be divided into following five categories:

- 1) Rigid or semi rigid blocks and boards (such as, mineral wool, expanded polystyrene boards);
- 2) Boards with impact or weather resistant surfaces suitable as exterior grade material;
- 3) Loose fill (such as, cellulose, fibre glass);
- 4) Foam and dry spray (such as, polyurethane or polyisocyanurate); and
- 5) Blankets, felts or sheets (such as, fibre glass, mineral wool, closed cell flexible elastomeric foam).

When specifying insulation, its key properties such as thickness, density, thermal resistivity/thermal conductivity value at specified

temperature, long term thermal retention, fire resistance, moisture resistance (structure open/closed cell), water vapour diffusion resistance, etc, should be specified. Insulation should be applied as per manufacturers' recommendations and in a manner so that it achieves rated insulation in terms of thermal resistance or *R*-value. Damaging or compressing the insulation reduces the effective *R*-value and compromises thermal performance of the construction assembly.

- b) *Thermal mass (increasing wall thickness)* — Thermal mass in walls enables time delay in impact of external environment on internal conditions. Thermally massive walls have high thermal capacity, and thermal storage capacity increases with increasing compactness, density and specific heat capacity of the materials. Walls (and other building elements such as roof and floor) can be used for thermal storage. The effectiveness of storing heat or coolness can be increased by creating a flow of fluid through the storage media.

Thermal mass is particularly effective in hot-dry climate with larger diurnal range. The building mass stores heat during daytime when outside temperature is high, and releases it to the inside space during night when outdoor temperature is cooler. Thermal mass is also used in storing heat during daytime in cold climates, to release it into the space during night, to warm it up when outdoor conditions are colder. Materials such as concrete, brick and water have high thermal storage capacity and can be used for such application. Storage mass exposed to direct sunlight should be dark in colour to allow larger absorption. It is generally more efficient to have thicker rather than thinner storage mass. The optimum thickness varies between 100 mm and 200 mm.

NOTE — There are ongoing developments based on research, regarding use of improvised materials with special properties such as phase changing characteristics which may be considered in future along with their implications from sustainability point of view.

- c) *Air cavities (Providing air cavities in walls)* — Air cavities in wall reduces heat gain factor. Performance is improved if the cavity is ventilated. Heat is transmitted through air cavity by convection and radiation. Cavity represents resistance that is not proportional to the thickness of the cavity. For thicknesses greater than 20 mm, the resistance to heat flow is nearly constant. Air cavity, however, may not be treated as replacement for higher

insulation, where needed as per the design requirements.

- d) *Surface finishes (Applying light coloured paints on walls)* — Surface colour and finish plays an important role in heat gain and loss from a structure. If external surface of a building is painted with light colour, it will reflect solar radiation. But if the emissivity of the surface colour in the long wave region is also high, the heat flux into the building is considerably reduced. For example, whitewash has a lower reflectivity than aluminium, but will stay cooler when exposed to high solar radiation, due to its high emissivity at low temperatures. The effect of colour on external surfaces is more evident in lighter structure, which offers low resistance to heat flow, and because of low thermal capacity. Ongoing research has made possible paints that are dark but reflect most off infrared (IR) radiation, thereby preventing excessive heat gain.

8.1.2 Roofs

The roofs of buildings receive most of heat throughout the day. Predominantly used construction practices in the country especially in urban areas, mainly involve reinforced cement concrete (RCC) as the roofing element, which has high thermal conductivity. If the roof is exposed to solar heat, the temperature inside will also rise as the day progresses. When buildings are air conditioned, the purpose of the system is to maintain inside the building, a lower temperature than the ambient. If the roof slab is exposed to solar heat, it will allow continuous heat inside the building which in turn will add to the air conditioning load. If the roof is protected from heat incidence by suitably insulating the roof from the heat, the conditions inside can be controlled to a large extent so that the living environment inside the building remains below the ambient temperature throughout the day. The function of roof insulation is to insulate the building against heat inflow from outside during the day. The options for roof insulation are given in 8.1.2.1 to 8.1.2.2. The overall thermal transmittance from the exposed roof should be kept as minimum as possible and under normal conditions, the desirable value should not exceed 0.58 W/(m²°C). The ceiling surface of floors which are not to be air conditioned may be suitably insulated to give an overall thermal transmittance not exceeding 1.16 W/(m²°C). Some traditionally adopted methods of roof construction like stone *Patti* and jack-arched roof may be used after evaluating their thermal performance. Mechanism to shade the roof with vegetation will help a great deal in lowering solar exposures.

8.1.2.1 Over-deck and under-deck insulation

In this system a thermal barrier or insulation is provided over RCC roof, so that the amount of heat of the sun reaching the RCC slab of the roof is substantially reduced to prevent the slab from getting excessively heated up. In contrast, if the thermal barrier is provided under RCC roof, as in under-deck insulation, some heat passes through it and heats up the ambience of the room. This decreases the comfort level of the room and if the building is air conditioned, increases the air conditioning load. Over-deck insulation is, therefore, considered advantageous over under-deck insulation in hot climates. Over-deck insulation also protects waterproofing system from damage due to thermal stress caused by continuous variation in diurnal and seasonal temperatures. It also acts as a protection against mechanical damage to water proofing systems. Over-deck insulation material should have adequate compression resistance, low water absorption, resistance to high ambient temperature and low thermal conductivity. Over-deck insulation applications may be carried out by either of the following methodologies:

- a) *Use of preformed insulation materials* — Preformed insulation materials used are classified as given below which may be laid, over the roof surface as per the manufacturers' recommendations:
 - 1) Expanded polystyrene sheet.
 - 2) Extruded polystyrene sheet.
 - 3) Polyurethane/polyisocyanurate sheet.
 - 4) Perlite board.
- b) *In-situ application using spray applied polyurethane* — This is applied directly over the roof by spraying. This insulation has advantage of non-interference with internal constructional/operational activities of a building, jointless adhesion to the roof surface due to seamless and monolithic nature of spray, and speedy application. *In-situ* spray application involves a mixture of atmospheric air leading to open cell formation and may affect insulation performance over time. Therefore, it is preferable in complex locations where use of rigid boards is difficult or not possible. This insulation needs to be treated with proper water proofing treatment ensuring no water ingress into the insulation, as in case of the waterproofing treatment getting damaged, the water ingress into the insulation may lead to deterioration and adversely affecting the insulation properties.
- c) *Conventional roof insulation practices* — There are a number of traditional roof insulation practices followed in the country

which have been effectively employed. These may include mud *phuska* and brick bat *coba*.

- d) *Other traditional practices of roof insulation* — Inverted earthen pots may also be used for roof insulation. In this system burnt clay pots are placed in inverted positions and covered with filler material. The air trapped inside the pots act as insulator and renders insulating property to roof. Suitable water proofing treatment needs to be additionally applied [see also 9.2.4.1.1 (m)].

Cellular concrete may also be used depending on the thermal insulation requirement.

The thermo-physical properties of different roof constructions are given in Table 2 and Table 3 for flat roof and sloped roof, respectively.

NOTE — Thermal conductivity values are indicative and many other/traditional practices may be employed for achieving desired thermal properties.

Thermal properties of some commonly used insulating materials and building materials are given in Table 4.

For thermal performance of flat and sloped roofs with use of various other considerations of materials and for thermal properties of building and insulating materials, refer to good practice [11(2)] and SP41 'Handbook on Functional Requirements of Buildings'.

- e) *Other over-deck systems that minimise heat gains* — There are other systems employing use of highly reflective and emissivity coatings that stay cooler in the summer thereby reducing energy costs, improving occupant comfort, cutting maintenance costs, increasing the life of the roof, and contributing to the reduction of heat island effect. Roofs with slopes less than 20° slope have a minimum initial solar reflectance of 0.70 and minimum emittance of 0.75. Cool roofs should be designed to have a minimum solar reflectance of 0.70 and a minimum thermal emittance of 0.75 or alternatively should achieve a minimum solar reflective index (SRI) of 82. Various types of cool roof systems are:
 - 1) *Roof coatings* — These may be field applied or factory applied. Field applied roof coatings are applied directly onto the roof surface and may require an appropriate primer. Factory applied coatings are applied in factory and include coatings applied to metal sheets. Specialized white elastomeric coatings may be used for sloped roofs and cool colour polymer coatings may be used for

Table 2 Typical Thermal Performance of Flat Roof Constructions

(Clause 8.1.2.1)

SI No.	Specification of Roof	U-Values W/(m ² .K)
(1)	(2)	(3)
i)	100 mm RCC	3.59
ii)	100 mm RCC + 100 mm lime concrete	2.78
iii)	100 mm RCC + 50 mm foam concrete + waterproofing	1.08
iv)	50 mm RCC + 25 mm expanded polystyrene	1.08
v)	50 mm expanded polystyrene + 50 mm RCC + waterproofing	0.62
vi)	25 mm expanded polystyrene + 50 mm RCC	1.09
vii)	100 mm RCC + 50 mm cinder concrete + 50 mm brick tile	2.07
viii)	100 mm RCC + 75 mm cinder concrete + 50 mm brick tile	1.76
ix)	115 mm RCC + 50 mm mud <i>phuska</i> + 50 mm brick tile	2.31
x)	115 mm RCC + 75 mm mud <i>phuska</i> + 50 mm brick tile	2.01
xi)	150 mm clay unit	3.15
xii)	137.5 mm clay unit	2.99
xiii)	150 mm clay unit + 100 mm lime concrete	2.21
xiv)	137.5 mm clay unit + 100 mm lime concrete	2.14
xv)	100 mm cellular unit + 85 mm lime concrete	2.27
xvi)	125 mm cord unit + 85 mm lime concrete	2.13
xvii)	154 mm lime concrete using stone aggregate + 76 mm stone slab	3.07
xviii)	88.9 mm concrete using brick aggregate + 25.4 mm kota stone slab on each side	3.65
xix)	50.8 mm lime concrete using ballast aggregate + 114 mm reinforced brick and bitumen wash on top	2.45
xx)	50.8 mm lime concrete using brick ballast aggregate + 50.8 mm RCC slab + bitumen wash on top surface	4.02
xxi)	100 mm RCC + Inverted clay pots with mud <i>phuska</i>	2.344
xxii)	100 mm RCC + Extruded polystyrene 25 mm-36 kg/m ³	0.749
xxiii)	100 mm RCC + Extruded polystyrene 30 mm-36 kg/m ³	0.658
xxiv)	100 mm RCC + Extruded polystyrene 40 mm-36 kg/m ³	0.528
xxv)	100 mm RCC + Extruded polystyrene 60 mm-36 kg/m ³	0.380
xxvi)	100 mm RCC + Extruded polystyrene 75 mm-36 kg/m ³	0.312
xxvii)	100 mm RCC + Expanded polystyrene 25 mm-24 kg/m ³	0.931
xxviii)	100 mm RCC + Expanded polystyrene 30 mm-24 kg/m ³	0.823
xxix)	100 mm RCC + Expanded polystyrene 40 mm-24 kg/m ³	0.670
xxx)	100 mm RCC + Expanded polystyrene 60 mm-24 kg/m ³	0.482
xxxi)	100 mm RCC + Expanded polystyrene 75 mm- 24 kg/m ³	0.409
xxxii)	100 mm RCC + Phenolic foam 25 mm-32 kg/m ³	0.725
xxxiii)	100 mm RCC + Phenolic foam 30 mm-32 kg/m ³	0.641
xxxiv)	100 mm RCC + Phenolic foam 40 mm-32 kg/m ³	0.511
xxxv)	100 mm RCC + Phenolic foam 60 mm-32 kg/m ³	0.363
xxxvi)	100 mm RCC + Phenolic foam 75 mm-32 kg/m ³	0.301
xxxvii)	100 mm RCC + Polyurethane spray 25 mm-42 + 2 kg/m ³	0.664
xxxviii)	100 mm RCC + Polyurethane spray 30 mm-42 + 2 kg/m ³	0.579
xxxix)	100 mm RCC + Polyurethane spray 40 mm-42 + 2 kg/m ³	0.460
xl)	100 mm RCC + Polyurethane spray 60 mm-42 + 2 kg/m ³	0.319
xli)	100 mm RCC + Polyurethane spray 75 mm-42 + 2 kg/m ³	0.259
xlii)	100 mm RCC + Polyisocyanurate spray 25 mm-42 + 2 kg/m ³	0.664
xliii)	100 mm RCC + Polyisocyanurate spray 30 mm-42 + 2 kg/m ³	0.579
xliv)	100 mm RCC + Polyisocyanurate spray 25 mm-42 + 2 kg/m ³	0.460
xlv)	15 mm cement plaster + 150 mm RCC + 100 mm brick bat coba + 43 mm polyurethane of 36 kg/m ³ + brick tiling	0.409
xlvi)	15 mm cement plaster + 150 mm RCC + 100 mm brick bat coba + 71 mm expanded polyurethane of 24 kg/m ³ + brick tiling	0.409
xlvii)	15 mm cement plaster + 150 mm RCC + 100 mm brick bat coba + 58 mm extruded polyurethane of 29 kg/m ³ + brick tiling	0.409
xlviii)	15 mm cement plaster + 150 mm RCC + 100 mm brick bat coba + 140 mm exfoliated vermiculite of 264 kg/m ³ + brick tiling	0.409
xlix)	15 mm cement plaster + 150 mm RCC + 100 mm brick bat coba + 43 mm polyisocyanurate of 32 kg/m ³ + brick tiling	0.409
l)	15 mm cement plaster + 150 mm RCC + 100 mm brick bat coba + 73 mm polyurethane of 36 kg/m ³ + brick tiling	0.261
li)	15 mm cement plaster + 150 mm RCC + 100 mm brick bat coba + 122 mm expanded polystyrene of 24 kg/m ³ + brick tiling	0.261
lii)	15 mm cement plaster + 150 mm RCC + 100 mm brick bat coba + 98 mm extruded polystyrene of 29 kg/m ³ + brick tiling	0.261
liii)	15 mm cement plaster + 150 mm RCC + 100 mm brick bat coba + 240 mm exfoliated vermiculite of 264 kg/m ³ + brick tiling	0.261
liv)	15 mm cement plaster + 150 mm RCC + 100 mm brick bat coba + 73 mm polyisocyanurate of 32 kg/m ³ + brick tiling	0.261

Table 3 Typical Thermal Performance of Sloped Roof Constructions

(Clause 8.1.2.1)

Sl No. (1)	Specification of Sloped Roof (2)	U-Values W/(m ² .K) (3)
i)	0.625 cm AC sheet	5.47
ii)	0.625 cm AC sheet + 2.5 cm air space + insulating board	2.44
iii)	0.625 cm AC sheet + air space + 5 cm fibre glass + 0.625 hard board	1.40
iv)	0.625 cm AC sheet + air space + 5 cm sandwich of fibreboard/ expanded polystyrene	0.65
v)	0.625 cm AC sheet + air space + 2.5 cm sandwich of fibreboard/ expanded polystyrene	1.22
vi)	0.3 cm GI sheet	6.16
vii)	2.5 cm tile + 2.5 cm bamboo reinforcement	3.56
viii)	5 cm tile + 2.5 cm bamboo reinforcement	3.20
ix)	2.5 cm thatch roof + 2.5 cm bamboo reinforcement	2.38
x)	5 cm thatch roof + 2.5 cm bamboo reinforcement	1.69
xi)	Mangalore tiles on wooden rafters	4.07

roof tiles, and these can be sprayed on existing roofs.

- 2) *Broken china mosaic terracing* — Properly sized broken pieces of glossy glazed tiles may be used as a cost effective cool roofing option.
- 3) *Cool colours* — Cool colour roofing materials are created by integrating pigments that reflect infrared energy, even though their colour may still absorb some of the visible spectrum. In this way, roofing products can be dark coloured and still be cool.
- 4) *Traditional methods* — Lime wash also renders similar property but has limited life and has to be reapplied.

Issues of excessive glare do arise with white roof coatings.

Table 4 Thermal Properties of Building and Insulating Materials at Mean Temperature of 50°C

(Clause 8.1.2.1)

Sl No. (1)	Type of Material (2)	Density kg/m ³ (3)	Thermal Conductivity W/mK (4)	Specific Heat Capacity kJ/kgK (5)
i)	Building materials:			
1)	Burnt brick	1 820	0.811	0.88
2)	Mud brick	1 731	0.750	0.88
3)	Dense concrete	2 410	1.74	0.88
4)	RCC	2 288	1.58	0.88
5)	Limestone	2 420	1.80	0.84
6)	Stale	2 750	1.72	0.84
7)	Reinforced brick	1 920	1.10	0.84
8)	Brick tile	1 892	0.798	0.88
9)	Lime concrete	1 646	0.730	0.88
10)	Mud <i>phuska</i>	1 622	0.519	0.88
11)	Cement mortar	1 648	0.719	0.92
12)	Cement plaster	1 762	0.721	0.84
13)	Cinder concrete	1 406	0.686	0.84
14)	Foam slag concrete	1 320	0.285	0.88
15)	Gypsum plaster	1 120	0.512	0.96
16)	Cellular concrete	704	0.188	1.05
17)	AC sheet	1 520	0.245	0.84
18)	GI sheet	7 520	61.06	0.50
19)	Timber	480	0.072	1.68
20)	Timber	720	0.144	1.68
21)	Plywood	640	0.174	1.76
22)	Glass	2 350	0.814	0.88
23)	Alluvial clay (40 percent sands)	1 958	1.211	0.84
24)	Sand	2 240	1.74	0.84
25)	Black cotton clay (Madras)	1 899	0.735	0.88
26)	Black cotton clay (Indore)	1 683	0.606	0.88
27)	Tar felt (2.3 kg/m ²)		0.479	0.88
28)	AAC block of 200 mm	749.6	0.089	1.0
29)	Fly ash clay brick	1 240	0.44	
30)	Sand lime brick	1 820	0.90	
31)	Vermiculite tiles	1 254	0.432	
32)	Perlite concrete	1 000	0.261	
33)	Expanded polystyrene concrete	932	0.231	

Table 4 — (Concluded)

(1)	(2)	(3)	(4)	(5)
ii) Insulating materials:				
1)	Expanded polystyrene	16.0	0.038	1.34
2)	Expanded polystyrene	24.0	0.035	1.34
3)	Expanded polystyrene	34.0	0.035	1.34
4)	Foam glass	127.0	0.056	0.75
5)	Foam glass	160.0	0.055	0.75
6)	Foam concrete	320.0	0.070	0.92
7)	Foam concrete	400.0	0.084	0.92
8)	Foam concrete	704.0	0.149	0.92
9)	Cork slab	164.0	0.043	0.96
10)	Cork slab	192.0	0.044	0.96
11)	Cork slab	304.0	0.055	0.96
12)	Rock wool (unbonded)	92.0	0.047	0.84
13)	Rock wool (unbonded)	150.0	0.043	0.84
14)	Mineral wool (unbonded)	73.5	0.030	0.92
15)	Glass wool (unbonded)	69.0	0.043	0.92
16)	Glass wool (unbonded)	189.0	0.040	0.92
17)	Resin bonded mineral wool	48.0	0.042	1.00
18)	Resin bonded mineral wool	64.0	0.038	1.00
19)	Resin bonded mineral wool	99.0	0.036	1.00
20)	Resin bonded mineral wool	16.0	0.040	1.00
21)	Resin bonded mineral wool	24.0	0.036	1.00
22)	Exfoliated vermiculite (loose)	264.0	0.069	0.88
23)	Asbestos mill board	1 397.0	0.249	0.84
24)	Hard board	979.0	0.279	1.42
25)	Straw board	310.0	0.057	1.30
26)	Soft board	320.0	0.066	1.30
27)	Soft board	249.0	0.047	1.30
28)	Wall board	262.0	0.047	1.26
29)	Chip board	432.0	0.067	1.26
30)	Chip board (perforated)	352.0	0.066	1.26
31)	Particle board	750.0	0.098	1.30
32)	Coconut pith insulation board	520.0	0.060	1.09
33)	Jute fibre	329.0	0.067	1.09
34)	Wood wool board (bonded with cement)	398.0	0.081	1.13
35)	Wood wool board (bonded with cement)	674.0	0.108	1.13
36)	Coir board	97.0	0.038	1.00
37)	Saw dust	188.0	0.051	1.00
38)	Rice husk	120.0	0.051	1.00
39)	Jute felt	291.0	0.042	0.88
40)	Asbestos fibre (loose)	640.0	0.060	0.84
41)	Closed cell flexible elastomeric foam - NBR	40-55	0.043	1.20

8.1.2.2 Green roof system

Green roofs have the potential to improve the thermal performance of a roofing system through shading, insulation, evapotranspiration and thermal mass, thus reducing energy demand of building for space conditioning. The green roof moderates the heat flow through the roofing system and helps in reducing the temperature fluctuations due to changing outside environment. If widely used, green roofs can reduce the problem of heat island effect which in turn reduces the energy consumption in urban areas. Green roof systems comprise a lightweight growing medium, plants and a root repellent layer in addition to the regular components of a roof. The additional components and thickness of the growing medium provides thermal insulation, while the green cover lowers ambient temperatures through evapotranspiration. Issues related to dead weight and water proofing should be considered while designing roof. There are three types of green roofs, as follows:

- a) *Intensive green roof*— It is like a conventional garden or park with almost no limit on the type of available plants including trees and shrubs.
- b) *Extensive green roof*— It is designed for little maintenance or human intervention once it is established.
- c) *Modular block green roof*— It is designed in modular units which interlock and each module contains drainage systems and plants.

Use of photovoltaic panels for renewable energy (see 8.3.2) can also be advantageously used for their effect on shading of roof top.

8.1.3 Fenestration

8.1.3.1 Of all the elements of building envelope, windows and glazed areas are most vulnerable to heat gains. Windows are required to bring inside natural daylight and wind, however, with light it also bring in heat. Proper location, sizing and detailing of windows

and shading form is therefore a very important aspect in a solar passive building design. Primary factors/components of a window which have significant impact on energy and cost of the building are window size and placement, glazing, frame, shading (external and internal), and screens or *Jalis*.

8.1.3.1.1 Window size and placement

The following may be taken into consideration:

- a) *Height of window head* — The higher the window head or lintel, the deeper the penetration of daylight.
- b) *Sill height (height from floor to the bottom of the window)* — The optimum sill for good illumination as well for good ventilation should be between the workspace and head level of a person. For carrying out any task, the suitable work plane levels shall be in accordance with 4.1.3.3 of Part 8 'Building Service, Section 1 Lighting and Natural Ventilation' of the Code. Strip windows provide more uniform daylight. Punched windows should be paired with work areas to avoid creating contrasts of light and dark areas. Windows close to task areas should be with optimum visual transmission without glare with good insulation performance as they may be source of thermal discomfort. Small horizontal openings close to the floors and the ceiling are extremely effective in reducing the window area to reduce heat ingress and provide adequate daylight levels in the space. In case of larger windows, glazing selection and shading effectiveness are quite important to control glare and heat gain.
- c) *Use of separate apertures for view and daylight* — For good day lighting and glare control, window should have clear glass with a partition for maximum daylight penetration and tinted glass below the clear glass for glare control. The structure in between the two provides a visual break and an opportunity to attach light shelf or shading device.
- d) *Window wall ratio (WWR)* — Window to wall ratio is the net glazing area (window area minus mullions and frame or approximately 80 percent of opening) divided by gross exterior wall area. Gross wall area is the overall area of a wall including openings such as windows and doors, with measurement taken horizontally from outside surface to outside surface and measured vertically from top of the floor to the top of the roof (see Fig. 4).

NOTE — The above represents only one approach in the entire range of window to wall ratio. The issue is primarily of window to wall ratio, and not window to glazing ratio.

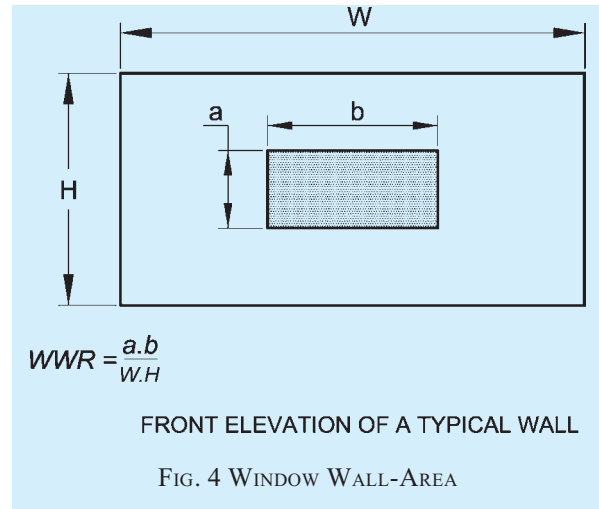

Screens make effective windows which reduce heat ingress and yet allow the air movement.

8.1.3.1.2 Glazing

The most commonly used glazing material in openings is glass, though recently polycarbonate sheets are being used for skylights. The primary properties of glazing that impact energy use in buildings are,

- a) visible transmittance (affecting daylight),
- b) visible reflectance (affecting heat and light reflection),
- c) thermal transmittance or *U*-value (affecting conduction heat gains),
- d) solar heat gain (affecting direct solar gain),
- e) spectrum selectivity (affecting daylight and heat gain),
- f) glazing material, and
- g) glazing colour (affecting the thermal and visual properties of glazing systems).

Use of insulated glazing units (IGU) may be considered in appropriate cases. IGU are hermetically sealed, multiple pane assemblies consisting of two or more glazing layers held and bonded at their perimeter by a space bar typically containing a desiccant material. The glazing used in IGUs may be clear, tinted or coated or reflective. The spacer serves to separate the panes of glass and to provide a surface for primary and secondary sealant adhesion. As heat transfer at the edge of the IGU is greater than its centre, the choice of material for spacer is critical to the performance of IGU. The hermetically sealed space between glass panes may be filled with dry air or other alternatives such as argon and krypton.

While selecting a glazing, attention should be given to the following:

- 1) Selecting between dual pane and single pane glazing.
- 2) Selecting a spectrally selective glazing (to keep off infra red and permit visible light).
- 3) Balancing the conflict between glare and light.
- 4) Trading off window size and glazing selection.
- 5) Dark or tinted glass may not necessarily provide good solar control.
- 6) Not depending on glazing alone to reduce heat gain and discomfort.
- 7) Selection of frame for glazing (see 8.1.3.1.3).
- 8) Varying the selection and configuration of a glazed facade.

8.1.3.1.3 Frame

The type and quality of window frame affects air infiltration and heat gain/heat loss characteristics of windows. Window frames are usually made of aluminium, steel, wood, PVC, RCC, fibreglass or composites of these materials. Wood, fibreglass, RCC and vinyl frames are better insulators than metal. Some frames are designed with internal thermal breaks that reduce heat flow through the frame. These thermally broken frames can resist heat flow considerably better as compared to those without thermal breaks. The sealing between the openings and the window frames, and between the opening sashes of windows and fixed portions, are important as major heat loss happens from this area due to poor design of sealant material, and should be ensured. Adequate provision shall also be made to ensure that the frames are not susceptible to water ingress in case of driving rain.

For further details, reference may be made to 9.2.3.2.

8.1.3.1.4 Shading devices

Direct sunlight can cause glare. Controls are therefore necessary to allow diffused natural light. Windows shading devices may be employed which help in keeping out the heat, block uncomfortable direct sun, and soften harsh daylight contrasts. Shading devices are also critical for visual and thermal comfort and for minimizing mechanical cooling loads. The three main ways of controlling direct sunlight are:

- a) External shading and screens/*Jalis*,
- b) Internal shading,
- c) Use of solar control glass (spectrally selective), and
- d) Horizontal/vertical or angled louvers.

8.1.3.2 Design for windows in air conditioned and non air conditioned spaces/mixed mode ventilated spaces

8.1.3.2.1 Windows in air conditioned buildings

Window (including both glazing and frame) affects the

energy performance of an air conditioned space by impacting the HVAC energy consumption of the building and also the energy consumption for indoor lighting. Following are major types of energy flow which occur through a window impacting the HVAC energy consumption (see also Fig. 5):

- a) *Non-solar heat losses and gains in the form of conduction, convection, and radiation* — The non-solar heat flow through a window occurs due to the temperature difference between the indoor and outdoor. Window loses heat to the outside during the winter season and gains heat from the outside during the summer season, adding to the heating/cooling load in a building.
- b) *Solar heat gains in the form of radiation* — The direct solar radiation entering into a conditioned space adds to the cooling load in summers and reduces heating load in winters in a building.
- c) *Infiltration* — Infiltration is the unregulated exchange of air between indoors and outdoors through joints and cracks around window frame, sash and glazing. The air tightness of a window depends on both the characteristics of the window such as sash type and overall quality of window construction and the quality of the installation. These air exchanges can significantly influence indoor thermal comfort and consequent heating and cooling loads.

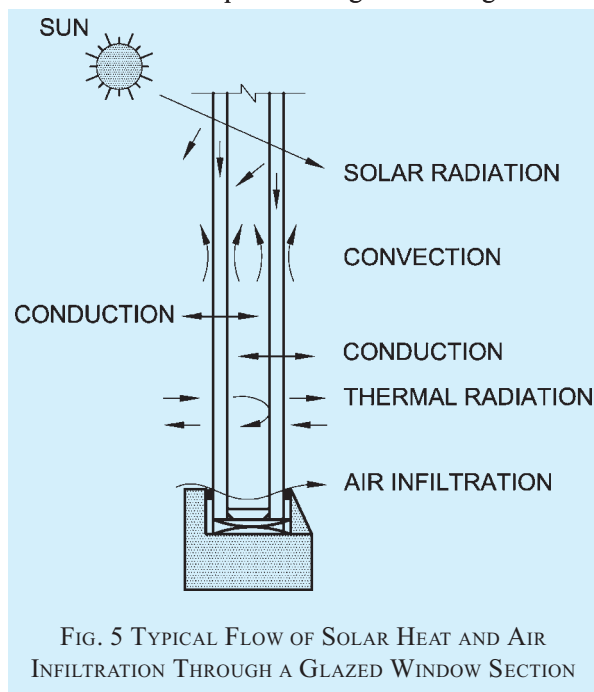

FIG. 5 TYPICAL FLOW OF SOLAR HEAT AND AIR INFILTRATION THROUGH A GLAZED WINDOW SECTION

Following are various parameters, related to the thermal performance of a window which should be considered to achieve energy efficiency in air conditioned building:

1) *U-value of fenestration* — The *U*-value of a single pane window is mainly due to the thin films of still air on the interior and moving air on the external glazing surfaces. The glazing itself doesn't offer much resistance to heat flow. Double glazing units, help reduce the *U*-value by creating still air (insulated) spaces. In addition to the normal double glazed windows, other options aimed at decreasing *U*-values, such as low-emittance (low-E) coatings and gas fills, may also be available. A low-E coating is a microscopically thin, virtually invisible, metal or metallic oxide coating deposited on a glazing surface. The coating may be applied to one or more of the glazing surfaces facing an air space in a multiple-pane window. The coating limits radiative heat flow between panes by reflecting heat. In case of air filled panes, the air-gap between window panes can be filled with gases which have better thermal resistance property than air such as argon and krypton.

For details regarding window frames and their thermal performance, reference may be made to **8.1.3.1.3**.

2) *Solar heat gain coefficient (SHGC) of fenestration* — Additional glazing layers provides more barriers to solar radiation, thus reducing the SHGC of a window. Tinted glazing, such as bronze and green, provide lower solar heat gain coefficients compared to the clear glass. Spectrally selective glazing, including some low-E coated glazing with low solar heat gain, block out part of the heat from the sun such as from infra-red radiations, while maintaining higher visible transmittances.

3) *Shading and adjusted SHGC* — Exterior or interior shading devices such as awnings, louvered screens, sunscreens, venetian blinds, roller shades, and drapes can complement and enhance the performance of windows with low SHGC. Many shading devices have an advantage that they can be adjusted to vary solar heat transmission with the time of day and season. Adjustable shades can also be integrated to permit some extra heat gain in the winter, if required.

Exterior shading devices are more effective than interior devices in reducing solar heat gain because they block radiation before it passes through a window. Light-coloured shades are preferable to dark ones because they reflect more and absorb less, radiation.

4) *Projection factor (PF)* — The projection factor for horizontal overhang and vertical fins may be taken as follows:

a) *For horizontal overhang* — Projection factor for overhang is calculated by measuring the depth of the overhang (*A*) and dividing that by the distance from the bottom of the window to the lowest point of the overhang (*B*) (see Fig. 6).

b) SHGC for a window having an external shading device can be calculated by multiplying the SHGC value of the window with the *M* factor given in Table 5 for different projection factors for different orientations. The factor *M* is the relative reduction in the annual solar cooling load attributed to the overhangs and/or vertical fins for the given projection factor.

Table 5 *M* Factor for Different Projection Factors for Different Orientations

[Clauses 8.1.3.2.1(4)(b) and B-3]

Location	Orientation	Overhang <i>M</i> Factor for the Projection Factor				Vertical Fin <i>M</i> Factor for Projection Factor				Overhang + Vertical Fin <i>M</i> Factor for Projection Factors			
		0.25 to 0.49	0.50 to 0.74	0.75 to 0.99	More than 1.00	0.25 to 0.49	0.50 to 0.74	0.75 to 0.99	More than 1.00	0.25 to 0.49	0.50 to 0.74	0.75 to 0.99	More than 1.00
(1)	(2)	(3)	(4)	(5)	(6)	(7)	(8)	(9)	(10)	(11)	(12)	(13)	(14)
15° North Latitude or greater	<i>N</i>	0.88	0.80	0.76	0.73	0.74	0.67	0.58	0.52	0.64	0.51	0.39	0.31
	<i>E/W</i>	0.79	0.65	0.56	0.50	0.80	0.72	0.65	0.60	0.60	0.39	0.24	0.16
	<i>S</i>	0.79	0.64	0.52	0.43	0.79	0.69	0.60	0.56	0.60	0.33	0.10	0.02
Less than 15° North Latitude	<i>N</i>	0.83	0.74	0.69	0.66	0.73	0.65	0.57	0.50	0.59	0.44	0.32	0.23
	<i>E/W</i>	0.80	0.67	0.59	0.53	0.80	0.72	0.63	0.58	0.61	0.41	0.26	0.16
	<i>S</i>	0.78	0.62	0.55	0.50	0.74	0.65	0.57	0.50	0.53	0.30	0.12	0.04

- c) *For vertical fins* — Projection factor for vertical fin is calculated by measuring depth of the vertical fin and dividing it by the distance from the window jamb to the farthest point of the external shading projection (see Fig. 7).
- 5) *Impact on lighting energy consumption* — During day time when natural light outside, is available in abundance, window can be utilized as a tool to harness natural light from Sun and sky to light the space. Buildings, in which artificial lighting is integrated with the day lighting, can reduce their energy consumption significantly. Good day lighting in a building depends upon the following factors:
 - a) *Window wall ratio (WWR)* — See 8.1.3.1.1(d).
 - b) *Visible light transmittance (VLT) of glazing.*
 - c) *Day-lighting and window design* — Day lighting is utilization of light from the sun and sky to augment or replace electric light. Appropriate fenestration and lighting controls can be used to modulate daylight admittance and to reduce electric lighting, while meeting the occupants' visual comfort.
 - d) *Day-lit perimeter zone for vertical fenestration* — The day-lit zone associated to a window can be defined as an area having a depth which is twice the window height (measured from ground) and having the width which is equal to the window width plus 1.0 m on each of

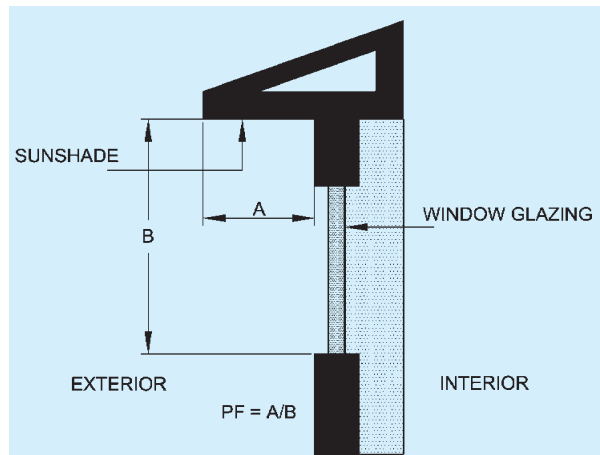

FIG. 6 PROJECTION FACTOR FOR HORIZONTAL OVERHANG FOR A TYPICAL WINDOW SECTION

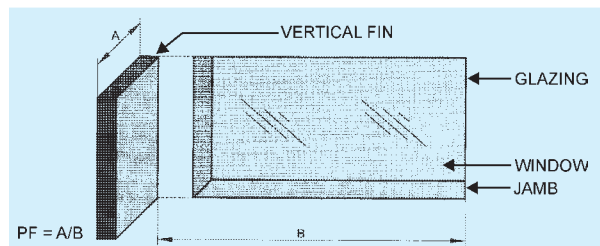
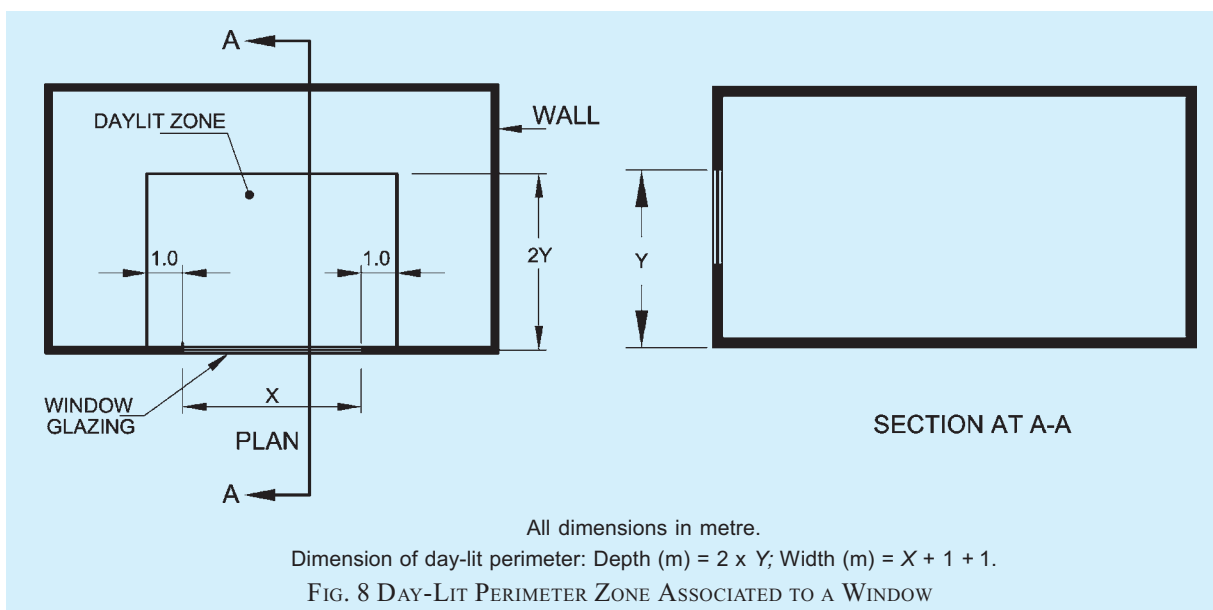

FIG. 7 PROJECTION FACTOR FOR VERTICAL FIN

the vertical sides of window as indicated in the Fig. 8.

The fenestration area, located above 1.0 m but below 2.2 m is considered as vision window area. The vision window area is usually provided with the glass with lower VLT in order to reduce glare.

The fenestration area located above 2.2 m is considered as daylight window area. Larger the daylight window



area more will be the daylight penetration into a space. The daylight window area is usually provided with glass with higher VLT so as to receive daylight to the greater depths of the space. The daylight window area can be designed in form of light shelves, as shown in Fig. 9, which enhance the penetration of daylight. The extent of natural light penetration into the room depends on the colour (reflectance) of the interior wall surfaces, the furnishing colour and partly the colour of the flooring.

The following should be determined and shall conform to the requirements of this Code:

- i) *U*-value for a fenestration product (including the sash and frame).
- ii) The SHGC for a fenestration product (including the sash and frame).
- iii) Air leakage through fenestration, shall not exceed 2.0 litre /s.m².
- iv) Window wall ratio on a facade, correlated to the visible light transmittance of the glazing which shall not exceed 60 percent.

NOTE — It may be noted that screens make effective windows which reduce heat ingress and yet permit natural ventilation.

8.1.3.2.2 Window design guideline for non-conditioned/mixed mode buildings

The following may be considered in selection of type of windows:

- a) *Horizontal pivot windows* — These produce very effective ventilation because large open areas are created at a separation equivalent to the window height. Air will tend to enter at the lower level and exit *via* the top of the window. These are easily adjustable to provide control of the ventilation rate. These are often used in taller buildings, as both sides of glass can be cleaned from the inside of the building with ease. The main disadvantage of this type of window is that, when opened, the top of

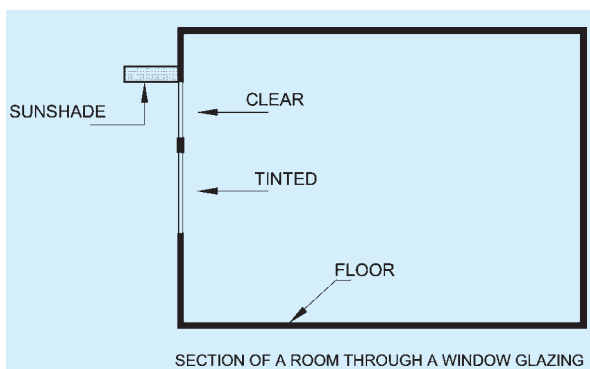

FIG. 9 ARRANGEMENT SHOWING VISION WINDOW AREA AND DAY LIGHT WINDOW AREA

the sash interferes with the curtains.

- b) *Vertical pivot windows* — These are less efficient than horizontal pivot windows because the open area is uniformly distributed throughout the height of the window rather than concentrated at the extremes; but these can work well in combinations. There is an advantage that these can be both opened and closed by pushing and are easy to clean from the inside. When fully open these offer a safe vertical barrier. The inward opening section may interfere with curtains when fully open.
- c) *Casement windows* — These offer the same advantages as vertical pivot windows but are susceptible to gusts. The most commonly used are double sided hinged outward opening windows which have great versatility with respect to air flow control. Most casement windows are designed to open outwards, which poses a problem for installation of window air conditioners.
- d) *Top/bottom hung windows* — These are less effective as ventilators than pivot windows as all the opening area is concentrated at one end, the top or bottom of the window.
- e) *Sliding windows* — These have similar characteristics as horizontal or vertical pivot windows. Sliding windows are easy to open; these slide to the side instead of having to be pushed inside/outside. A good seal is important in reducing draughts and energy loss when closed. Cleaning the inside of slider windows is easy, but cleaning the outside may be difficult.
- f) *Tilting top vents* — These provide smaller opening areas than the other systems as these occupy only a relatively small proportion of the window height. However, these can provide good draught-free ventilation, especially in cross-ventilation mode. The inward opening function of tilt and turn windows limit the available space.

The window may also be provided with fixed/sash/sliding/roller insect screens to allow fresh air without the inlet of mosquitoes and other insects through openable windows.

As compared to air-conditioned spaces, the window design in non-conditioned/mixed mode buildings takes a different approach. The glazing system for windows in non-conditioned/mixed mode spaces is usually single pane/panel glazed units as the windows will be opened to allow ventilation. Thus there is less relevance to install double glazing units with low SHGC and *U*- values.

However, in the non-conditioned/mixed mode buildings the shading device plays a crucial role in the thermal performance of a window. Windows on facades, for different orientations, should be provided by the shading devices which can cut the direct incident solar radiation for the critical solar angles.

In the non-conditioned buildings/mixed mode buildings, penetration of direct solar radiation needs to be regulated. The critical Horizontal Solar Angle (HSA) and Vertical Solar Angle (VSA) (see Fig.1) for fenestrations located on the cardinal directions should be regulated by designing appropriate shading devices. The horizontal solar angle at critical hours can be regulated by the vertical fins provided as external shading devices. The vertical solar angle at critical hours can be regulated by the horizontal fins provided as external shading devices.

The maximum permissible WWR on a facade should not exceed 60 percent. Window opening requirements for naturally ventilated low rise residential and office buildings include the following:

- a) In order to allow outside air to enter the space, window openings should be oriented appropriately to optimize heat and solar heat gain.
- b) In order to facilitate cross ventilation, location of window openings should be located opposite to each other on walls parallel to each other.
- c) In order to achieve the required air change per hour in a given space, cross ventilation and stack ventilation mode of natural ventilation should be adopted.

The external shading devices can be designed in various ways to stop the solar radiation entering through the window. Figure 10 shows the commonly used shading devices.

Example to design shading device for a window

Design of shading device for a window of height 1.5 m and width 3.0 m to cut the HSA of 45° and VSA of 60° should be as follows:

- a) *Design of shading device to cut the VSA* — The vertical solar angle of 60° can be cut by providing a single horizontal overhang of length 867 mm or it can be cut by providing two horizontal projections 60 mm thick each of length 415 mm placed at a distance of 720 mm as shown in Fig.11.

The length and spacing can be calculated either by the drafting softwares by graphical method or by manually calculating using the following formula:

Depth of shading device
 = Spacing between the shading device × tan (90° – VSA)

For a given VSA, either of the values for depth or spacing between shading overhangs can be selected to get the value of the other.

- b) *Design of shading device to cut the HAS* — The horizontal solar angle of 45° can be cut by providing a single vertical fin of length 3 000 mm or it can be cut by providing four vertical fins 60 mm thick each of length 705 mm placed at a distance of 705 mm as shown in Figure 12.

The length and spacing can be calculated either by the drafting softwares by graphical method or by manually calculating using the formula:

Depth of vertical fins = Spacing between the vertical fins × tan (90° – HSA)

For a given HSA either of the values for depth or spacing between vertical fins can be selected to get the value of the other.

It is desirable to break single overhang with larger depth into multiple overhangs of smaller length. It enhances the amount of (diffused) daylight penetration in the space. Figure 13 shows the comparison between amount of daylight penetration for two shading devices, one with single deep overhang and the other with multiple smaller overhangs. Another alternative is use of screens which make effective window/opening protection by reducing heat ingress and yet permitting air movement.

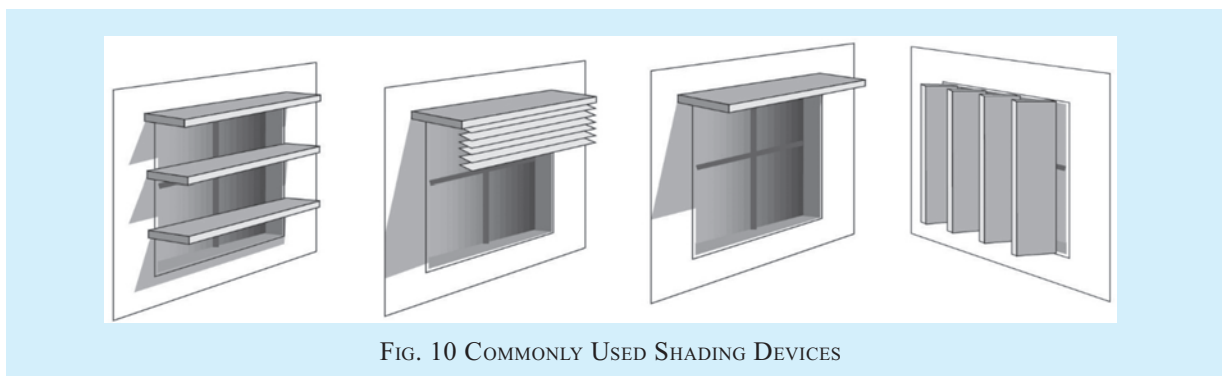
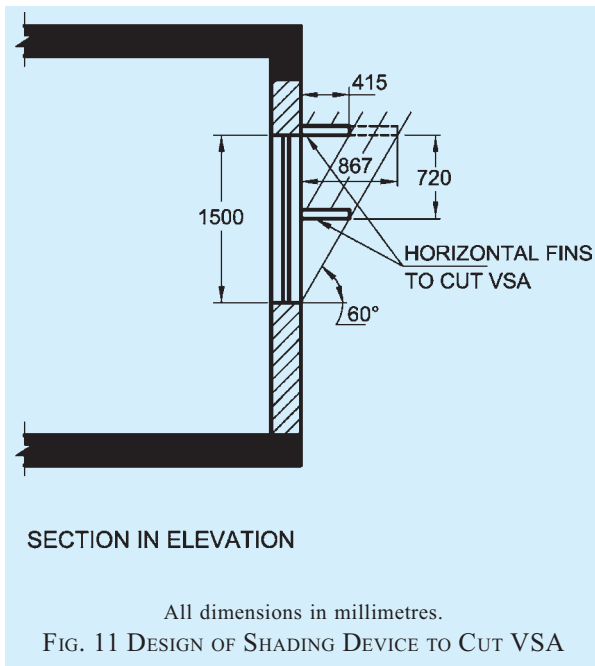

FIG. 10 COMMONLY USED SHADING DEVICES



Window design for natural ventilation — Windows are required to provide natural cooling through ventilation. Optimized window design helps to achieve thermal comfort with no additional energy and/or financial investment. Optimized window design helps to reduce dependence on air conditioning where natural ventilation is possible and helps in reducing discomfort in naturally ventilated spaces. Following are the general guidelines for achieving effective natural ventilation:

- 1) Natural ventilated buildings should take advantage of the predominant wind originating from east and west directions to maximize cross ventilation. Stack ventilation can be enhanced by providing openings on the opposite side of the wall, where the inlet opening should be located at the bottom most part of the wall and outlet openings should be on the topmost part of the opposite wall in order to increase the height difference between the two (see Fig. 14).
- 2) Naturally ventilated buildings should have a narrow room width; and it is difficult to naturally ventilate buildings with room depth more than 15m.
- 3) For total area of openings (inlet and outlet) of 20 to 30 percent of floor area, the average indoor wind velocity that may be achieved is around 30 percent of outdoor wind velocity. Even on increasing the size of window further, the maximum indoor wind velocity does not exceed 40 percent of outside wind velocity.
- 4) To enhance physiological comfort through natural ventilation, the bottom side of the

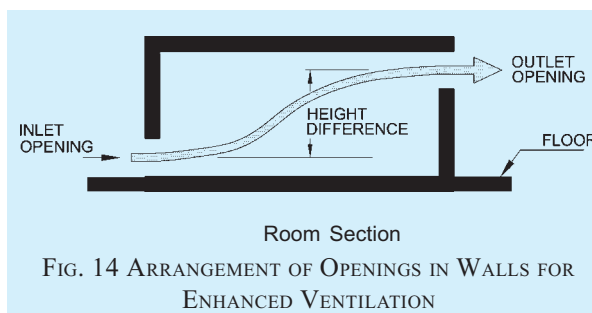
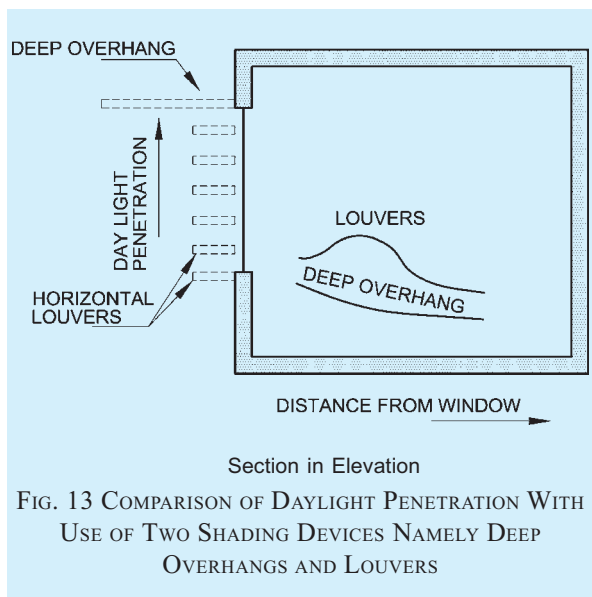
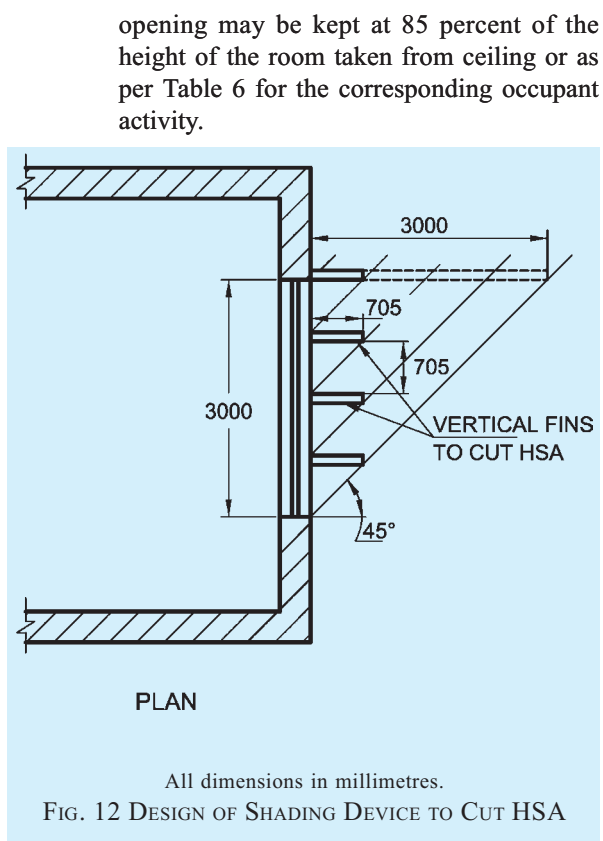

Table 6 Critical Height Requirement for Physiological Cooling
[Clause 8.1.3.2.2(d)]

SI No.	Pattern of Activities	Recommended Height of the Bottom Side of Opening
(1)	(2)	m (3)
i)	Sitting on chair	0.75
ii)	Sitting on bed	0.60
iii)	Sitting on floor	0.40

- 5) Clerestory or vented skylight provides an opening for vitiated air to escape through natural buoyant ventilation. The light well of the skylight may also act as a solar chimney to augment natural buoyant flows.
- 6) Openings in lower part of the structure, such as basement windows, should be provided to complete the ventilation system.

8.2 Envelope Optimization Methods for Energy Efficiency

Envelope optimization methods are important tools for optimizing the design of building envelope from energy efficiency point of view. Any of the following envelope optimization methods may be employed to achieve the objective:

- a) *Prescriptive method* — This method specifies a set of prescriptive requirements for building systems and components. Compliance with these requirements can be achieved by meeting or exceeding the specific levels described for each individual element of the building systems. Envelope optimization using this method shall be carried out in accordance with Annex B.
- b) *Trade-off method* — This is a systems-based approach, where the thermal performance of individual envelope components can be reduced, if compensated by higher efficiency in other building components (for example, using higher wall insulation could allow for a less stringent U -value requirement for windows, or *vice-versa*). These trade-offs typically occur within major building systems – roofs, walls, fenestrations, overhangs, etc. This method offers the designer more flexibility than strictly following the prescribed values for individual elements. The thermal performance of one envelope component such as the roof can fail to meet the prescriptive requirements as long as other components perform better than what is required to make necessary compensation.

Trade-offs are permitted only between building envelope components. It is not permitted, for instance, to make trade-offs against improvements in the lighting or HVAC systems. However, this method makes using the envelope trade-off option more complicated than the prescriptive method. It is necessary to calculate the surface area of each exterior and semi-exterior surface; all areas are required to be calculated separately for each orientation. Envelope optimization using this method shall be carried out in accordance with Annex C.

- c) *Whole building analysis method* — This method models the thermal, lighting, ventilation occupancy, and other energy-consuming processes taking place within the building to simulate and predict its energy performance. The simulation programme takes into account the building geometry and orientation, building materials, building facade design and characteristics, climate, indoor environmental conditions, occupant activities and schedules, HVAC and lighting system and other parameters to analyse and predict the energy performance of the building. This may be done using computer simulation models, which can be accomplished with a variety of proven software tools and in many cases may be the best method for guiding a building project to be energy-efficient. However, this approach does require considerable knowledge of building physics and building simulation tools and very close communication between members of the design team. Envelope optimization using this method shall be carried out in accordance with Annex D.

8.3 Renewable Energy Integration in Envelope

8.3.1 Integration of Solar Thermal Technologies

Solar collectors that harness the solar energy directly into usable heat can be aesthetically integrated with the building envelope or they may be mounted on the roof of building.

8.3.2 Integration of Photovoltaic Technologies

Building integrated photovoltaic (BIPV) system is the integration of photovoltaic (PV) and the building envelope. The PV modules can be designed and installed to serve the double purpose of both power generation and that of the building skin replacing conventional building envelope materials. By avoiding the cost of conventional materials, the incremental cost of photovoltaic is reduced and its life cycle cost is lower.

A complete BIPV system includes the following:

- a) PV modules (which may be thin-film poly or mono crystalline, amorphous with transparent, semi-transparent, or opaque backing);
- b) Charge controller, to regulate the power into and out of the battery storage bank (in stand-alone systems);
- c) Power storage system, generally comprising utility grid in utility-interactive systems or, a number of batteries in stand-alone systems;
- d) Power conversion equipment including an inverter to convert the d.c. output of PV modules to a.c. compatible with the utility grid;
- e) Backup power supplies such as diesel generators (optional), typically employed in stand-alone systems; and
- f) Appropriate support and mounting hardware, wiring, and safety disconnects.

While photovoltaic panels as in (a) are considered as PV array, other components given in (b) to (f) are usually referred to as the balance of system (BoS). Not only solar photovoltaic technologies but other ways of producing renewable energy may also be integrated in to design, depending upon suitability to geomorphological conditions, geo-thermal pumps, wind, etc.

9 MATERIALS

9.1 General

Building materials choices are important in sustainable design because of the extensive network of activities such as extraction, processing and transportation steps required for making a material, and activities involved thereafter till building construction and even thereafter. These activities may pollute the air, soil and water, as well as destroy natural habitats and deplete natural resources.

One of the most effective strategies for minimizing the environmental impacts of material usage is to reuse existing buildings. Rehabilitation of existing building, their shell and non-shell components, not only reduces the volume of solid waste generated and its subsequent diversion to landfills but also the environmental impacts associated with the production, delivery and use or installation of new building materials.

The use of rapidly renewable materials, recycled materials minimises the adverse impact of natural resource consumption in the manufacture of new building materials. The use of local materials supports the local economy and reduces the negative impact of transportation.

9.1.1 *Environmental Concerns and Human Health and Safety Aspects Related to Building Materials*

Increased demand for building materials creates a major and diversified impact on the environment. Excessive extraction of raw material diminishes non-renewable natural resources very rapidly. Even during some extraction process, waste is generated whose disposal may pose problems. Sometimes extraction processes may also affect the wildlife. Transportation of building materials from one place to another is also a major indirect factor leading to harmful effects. During manufacturing or processing of some materials like plastic, harmful gases are generated, which are dangerous for human health and environment. There are many frequently used building materials like reconstituted wood products, paints, glues, carpet and upholstery, which may release gases, fumes, etc, from the chemical components used, even long after the installation. These volatile organic compounds (VOCs) affect the environment and human health and may cause headaches, dizziness, respiratory problems and even major diseases in human and other living beings.

9.1.2 *Minimizing Green House Gas (GHG) Emission*

Construction sector in the country is a major consumer of energy resulting in the largest share of CO₂ emissions in the atmosphere. Cement, steel and bricks, the largest and bulk consumption items in the construction industry, are contributors of large CO₂ emissions. It is estimated that close to a tonne of CO₂ is emitted during the production of every tonne of cement, resulting in very high GHG emission. Similarly, bricks and concrete, which are very widely used construction material have very high GHG emission. Minimizing the consumption of such conventional materials which may contribute to substantial GHG emission, by using alternative materials and alternative methods and techniques can considerably reduce energy and CO₂ emissions.

9.1.3 *Building Material*

An ideal sustainable building material is not only environment friendly, causes no adverse impact on health of occupants, is readily available, can be reclaimed, can be recycled and is made from renewable raw material, but also uses predominantly renewable energy in its extraction, production, transportation, fixing and ultimate disposal. Practically, this kind of ideal material may not be available, hence when selecting sustainable materials, it may be best to choose materials which fulfill most of these criteria.

9.1.4 *Life Cycle Assessment (LCA) of Building Materials*

LCA of building materials intends to assess the potential environmental impacts at every stage in the life cycle

of a material (*see* Fig. 15) right from the raw material sourcing, processing, manufacturing and finishing, up to the product installation, maintenance and ultimately reuse/recycle/demolition. It is a tool to determine the environmental suitability of any building material for a thorough understanding of the environmental impact and the improvement which can be employed at every stage of a material, so as to make a decision for its selection after evaluation of criteria such as embodied energy, performance and durability.

A description of life cycle analysis with respect to various relevant criteria is given below:

- a) *Embodied energy* — It is an important factor to be considered in the life cycle assessment of a material. Minimizing embodied energy means minimizing the impact on the environment. In any building construction use of materials with low embodied energy should be considered.

Table 7 gives classification of building materials based on their energy intensity and gives the comparative embodied energy for a few building materials.

- b) *Resource reuse and upgradation* — It includes saving a material from disposal and utilizing it by renovating, repairing, restoring, or generally improving the appearance, performance, quality, functionality, or value of a product. Efforts should be made to reuse existing, previously occupied buildings – including the structure, envelope and elements, after removing or replacing the elements which have risk of failure/contamination during construction or occupancy. Upgradation of systems should be done in the areas of energy and water efficiency where the previously installed systems are not environment friendly or efficient.
- c) *Recycled content* — To reduce the demand for virgin materials, effort should be made to use the products with identifiable recycled

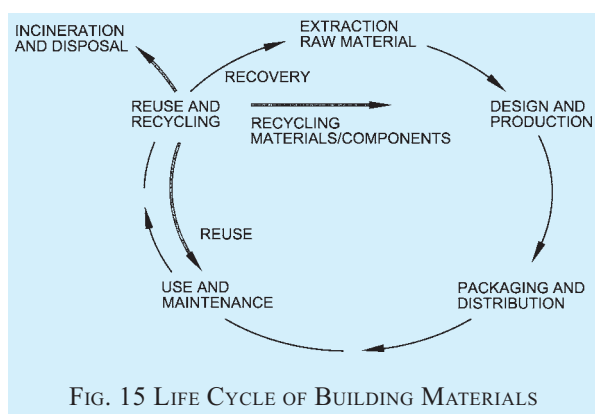

FIG. 15 LIFE CYCLE OF BUILDING MATERIALS

Table 7 Classification of Materials Based on Energy Intensity

[Clause 9.1.4 (a)]

Sl No.	Category of Material	Energy Intensity (Range) GJ/t	Examples
(1)	(2)	(3)	(4)
i)	Very high energy	>50	Aluminium, stainless steel, plastic, copper, zinc
ii)	High energy	5-50	Cement, steel, glass, bitumen, solvents, cardboard, paper and lead
iii)	Medium energy	1-5	Lime, gypsum plaster board, burnt clay brick, burnt clay brick from improved vertical shaft kiln, aerated block, hollow concrete block, gypsum plaster, concrete block, timber, wood products, particle board, medium density fibre board, cellulose insulation, <i>in-situ</i> concrete
iv)	Low energy	<1	Sand, aggregate, fly ash and fly ash based products, cement stabilized soil block, straw bale, bamboo, stone

NOTES

1 While comparing embodied energy of building materials, the total quantity by mass of the material times the embodied energy value per unit mass (energy intensity) of the material to be installed for same surface area of the building may be compared.

2 The values given in the table are comparative values, and in case of substantial difference in the transportation component of the materials in question, the same should also be taken into account while calculating the embodied energy.

content, including from those coming from industrial and post-consumer utilization, with a preference for the later.

- d) *Reusable or recyclable* — Effort should be made to select materials that can be easily dismantled and reused or recycled at the end of their useful life. Consider installation techniques which allow easy dismantling and reuse of materials.
- e) *Natural, plentiful* — Effort should be made to use materials which are bio-based and naturally harvested from sustainably managed sources.
- f) *Bio-degradable* — Consider using materials which are bio-degradable so that they can be harmlessly disposed at the end of their life cycle.
- g) *Indigenous or locally available* — Effort should be made to use building materials, components, and systems which are found locally or regionally, saving energy and resources for transportation of materials to the project site.

- h) *Rapidly renewable material* — Effort should be made to use materials which replenish substantially faster than traditional extraction demand (for example, timber which can be planted and harvested in less than a 10 year cycle) to reduce the demand for limited/finite resources.
- j) *Materials compliant with clean air and clean water* — Effort should be made to select those materials that emit few or no carcinogens, reproductive toxicants, VOCs, etc. Such materials that enhance the indoor environment quality and consume less water, do not cause water contamination, pollution as well as help in reducing water consumption should be considered for use.
- k) *Materials having low ozone depletion potential* — Efforts should be made to select materials which do not use in their manufacture, chemicals that have an ozone depleting potential (ODP).

9.2 Materials and Recommended Sustainable Alternatives

For quality requirements of building materials reference shall be made to National Building Code of India: Part 5 'Building Materials' of the Code. General guidelines and considerations for use of different structural and surface finishing materials and with alternatives for helping in sustainable construction, are given under 9.2.1 and 9.2.2.

9.2.1 Structural Materials

9.2.1.1 Cement concrete

Concrete is a strong, durable material and provides good thermal mass to buildings. However, manufacture of cement used in it is a high energy-intensive process and source of pollution, requiring also high energy for its transportation due to centralized production. Extraction and mining of aggregates also result in natural habitat destruction or deforestations. Following are the recommended alternatives to conventional concrete:

- a) *Use of pozzolanas and other mineral admixtures for cement replacement in cement concrete and other cement matrix products:*
 - 1) *Use of fly ash and slag in cement concrete* — Pozzolanas like fly ash or ground slag may be used to replace certain percentage of ordinary Portland cement in cement concrete in accordance with the good practice [11(3)] or cement manufactured by using mineral admixtures like fly ash or ground slag may

- be used, in accordance with the good practice [11(3)].
- 2) *Rice husk ash (RHA)* — Rice husk ash, a waste from rice industry, is pozzolanic in nature and may be used for part replacement of cement in accordance with the good practice [11(3)].
- 3) *Ready mixed concrete (RMC)* — RMC provides opportunity for use of pozzolanas and slag in greater quantities while maintaining strict quality control. Also, there are advantages of RMC over conventional concrete such as reduction noise and dust pollution, apart from better quality control. Preference may be given to use of RMC, if the RMC manufacturing plant is nearby. The manufacture, quality control delivery, etc of RMC shall be done in accordance with the good practice [11(4)].
- 4) *Geopolymer concrete* — It is made with fly ash, ground granulated blast furnace slag (GGBS), fine aggregates and coarse aggregates and catalytic liquid system (CLS). This concrete uses no Portland cement and utilizes waste products. It has good resistance to chloride penetration and acid attack. However, geopolymer concrete is a future sustainable material option as it is in development stage. It could be designed and developed for a specific use in a project for which specialist literature may be referred.
- 5) *Other cement concrete mix and products/ cement matrix products/lime-pozzolana mixtures* — Various cement concrete mix and products, other cement matrix products, lime-pozzolana mixtures, etc, used in buildings having waste based/by-product mineral admixtures such as fly ash and slag may be produced or used. The requirements of such products and for their utilization shall be in accordance with accepted standards and good practice [11(5)] which also includes list of accepted standards for mineral admixtures for use in such products as may be applicable.
- b) *Use of recycled aggregate* — Crushed concrete aggregate is most common form of recycled aggregate which should be considered for use in concrete. The recycled concrete aggregate should be intended to offer the same level of strength and durability as conventional aggregate from natural

resources. In the concrete mix, both virgin aggregate from natural resources and recycled aggregate may be mixed with hydrated cement paste. Such mix may have reduced specific gravity and increased porosity compared to concrete using similar virgin aggregate from natural sources. It is recommended that recycled aggregate be batched in a pre-wetted and close-to-saturated surface dry condition. Recycled aggregate may be used in concrete for bulk fills, bank protection, base/fills of drainage structures, pavements, sidewalks, kerbs and gutters, etc. Up to 30 percent of natural crushed coarse aggregates can be replaced by the coarse recycled concrete aggregate, in fresh concrete. This percentage can be increased up to 50 percent for pavements and other areas which are under pure compression. Also refer good practices [11(3)]. For quality requirements for other/artificial aggregates such as cinder as fine aggregate in lime, broken burnt clay bricks as coarse and fine aggregates, artificial light weight aggregates, etc, reference may be made to the accepted standards [11(6)].

- c) *Precast/prefabricated/partially prefabricated concrete elements* — Precast concrete can be used in construction in the form of building elements which are assembled at site and made monolithic by pouring *in-situ* concrete. The products are manufactured by casting concrete in a reusable mould or form which is then cured in a controlled environment, transported to the construction site, and erected at place. Precast concrete elements break the structural elements into smaller segments resulting in ease and economy in construction. Precast concrete roofing techniques like plank and joist roofing system, ferrocement roofing channels, precast arch panels, precast waffle units, L-panels are among roofing systems which may have comparatively less embodied energy than conventional RCC roof.
- d) *Use of light weight concrete:*
- 1) *Preformed foam concrete* — Preformed foam concrete may be considered for use for the levelling of floors, sprayed onto horizontal surfaces or in hollow cavities as light weight filler.
 - 2) *Ferrocement* — Ferrocement is a thin cement mortar laid over wire mesh (which acts as reinforcement). It uses minimal material (particularly steel) which is reduced compared to conventional RCC.
- e) *Use of light weight aggregates in concrete* —

These are usually used in masonry blocks, slabs or floor beam units which are relatively strong. Light weight blocks help to reduce structural loading of building. These may be foamed blast furnace slag, bloated clay aggregate, sintered fly ash aggregate, cinder aggregate, etc. Mineral insulating aggregate in concrete like light expanded clay, pumice and expanded perlite have the lower moisture absorption coefficient, and are therefore best suited to products used for insulation. Fossil meal and exfoliated vermiculite, perlite or slag due to very high moisture absorption coefficient is preferred for high temperature equipment insulation. If artificial lightweight aggregate is used for making lightweight concrete, the same shall be in accordance with the accepted standard [11(7)].

- f) *Commonly used masonry concrete blocks:*
- 1) *Solid and hollow concrete blocks* — Hollow concrete block masonry uses lesser concrete as compared to solid concrete blocks and provides better thermal insulation due to cavity. Filling of the cores with concrete or concrete with steel reinforcement offers much greater tensile and lateral strength to structures, wherever required.
 - 2) *Autoclaved cellular (aerated) concrete blocks* — These are made by mixing fly-ash, lime, cement and gypsum, with foaming agent like aluminium powder which gives them the lightweight and good insulation property. These are lightweight blocks which can be useful to reduce dead load on structure, particularly of high rise buildings.
 - 3) *Lightweight concrete blocks* — These blocks are lightweight and manufactured like normal concrete blocks using light weight aggregates.
 - 4) *Preformed foam cellular concrete blocks* — These have considerably better thermal insulation properties than normal bricks or concrete.
 - 5) *Concrete stone masonry blocks* — Precast concrete stone block masonry which uses recycled stone is a viable option. It can be made with waste stone pieces which could be locally available, and lean cement concrete.

The design mix of concrete blocks can also be done using fly ash as replacement of certain percentage of cement by volume. The concrete blocks shall be in accordance with the

accepted standards [11(8)] and masonry construction using these blocks shall be in accordance with good practice [11(9)].

9.2.1.2 *Burnt clay bricks and tiles*

Bricks are made of clay which is abundant and generally sourced locally. They are durable and provide thermal mass to buildings. They are used for applications such as wall masonry, cladding, flooring and roof tiling. In many cases bricks can improve the indoor climate by regulating and stabilizing moisture levels.

Clay building waste being inert, its disposal has no detrimental effects on the environment. Exceptions are coloured and pigmented brick and ceramic tiles containing heavy metals, fire proof bricks containing soluble chrome and bricks from chimneys which have absorbed large amount of aromatic hydrocarbons during their life span. These products have to be separated and disposed of by following special precautions.

The burnt clay products have high durability, and these have high potential for their reuse as the energy needed to remove and clean up old material only represents approximately 0.5 percent of the energy required for the manufacture of new bricks and tiles. However, the recovery for reuse of bricks is facilitated, if a weak or medium-strength mortar has been used. Ceramic tiles or expanded clay pellets cannot be recycled and have to be usually more down-graded for uses such as for use as fill. Clay tiles and bricks can be broken up and used as fill, and aggregate in concrete in accordance with the good practice [11(3)].

Brick and clay manufacturing is a medium to high energy intensive and polluting process depending on the firing temperatures and type of kilns used in firing. Preference should be given to locally manufactured bricks and tiles to reduce transportation energy. The vertical shaft brick kiln technology which substantially reduces both the embodied energy and resultant emissions from brick production may be used. The consumption of energy in the kilns can be reduced considerably by the use of bricks with different firing temperatures, in different parts of the building.

The following other types of bricks may also be used as sustainable alternatives:

- 1) *Hollow/perforated bricks* — These types of bricks save the amount of material used and provide better thermal insulation due to the presence of air cavities. These bricks when provided with reinforcements can be used for structural applications and also in the form of filler blocks to replace concrete in the tensile zone.

- 2) *Low and medium-fired bricks* — Clay bricks which are burnt between 350°C and 500°C are low-fired bricks, and bricks burnt at slightly higher temperature like 500°C to 800°C are medium-fired bricks. Low-fired bricks are highly absorbent and hence recommended for use in internal walls or inner layer of external cavity walls (where they act as a moisture regulator), etc. The medium-fired bricks although comparatively more durable, may be used in similar applications as above.
- 3) *Burnt clay flyash bricks* — They are lower in embodied energy, provide better thermal property as compared to conventional burnt clay bricks and also utilize flyash, an industrial waste product.
- 4) *Flyash lime bricks* — These are flyash based and use bricks lime as the binder, along with accelerator in required proportion. These have good thermal properties. These are mostly used as masonry units and as fillers in pre-fabricated floor slabs.
- 5) *Red mud burnt bricks* — Red mud is a waste product from aluminium extraction industry. It contains mainly oxides of aluminium, iron and titanium. Red mud and flyash partly replace clay in these bricks. The alumina content gives a nice red tone to the brick. They have high compressive strength and are suitable for all types of construction. The presence of 4 to 5 percent of alkali in red mud also results in better plasticity and better bonding in these bricks.
- 6) *Lato bricks* — These are strong bricks (south western region of India) made of laterite soil mixed with cement or lime, and are moulded under pressure instead of being fired.

For quality requirements of bricks, reference shall be made to Part 5 'Building Materials' of the Code.

9.2.1.3 *Traditional efficient building materials*

Each region in the country has developed unique ways of using locally available building material such as stone, timber, bamboo and soil. These building technologies have been developed over time, based on availability of natural materials, climatic considerations and culture. These techniques are not only environment friendly and energy efficient but are also cost effective as they involve the use of materials which are locally available reducing cost and energy on transportation.

9.2.1.3.1 *Earth construction*

Earthen buildings are easily recyclable, fire resistant, biodegradable, non-toxic, and have good thermal and sound absorption and moisture regulating properties.

This type of construction can easily use onsite earth or locally available material depending on the quality of the earth available. Two main ways of making earthen buildings are ramming, where the earth is rammed between shuttering to make walls, and use of earth block (adobe), where the earth is first pressed into blocks and dried before use. Stabilizers such as cement or lime may be added to improve durability. Straw and sawdust act as reinforcement as well as increase the insulation value. Well mixed, homogeneous earth construction has structural properties. Various options/considerations in this area are:

- a) *Adobe bricks* — These were made earlier with sand and clay mixed with a small proportion of water. Straw and/or grass are included as binder. Mixture is either poured into moulds or allowed to dry or it is pressed into blocks using hydraulic or lever press. Adobe can be made from wide range of soils but require plastering as they are not water-resistant. They have low structural strength but can be easily used for load bearing structures if, built between timber/concrete frames.

Stabilized adobe block construction is a new improved system of construction in which stabilization is done by adding fibres (plant or animal fibres), binders (cement, lime, pozzolanas, etc) and sometimes water proofing agents (bitumen, natural and synthetic resins). This kind of construction is suitable for areas with higher rainfall, condensation, flooding, etc. Proportion of soil content in stabilized adobe blocks may be: coarse sand 40-75 percent; clay 10-25 percent; silt 15-25 percent; and fine gravel 0-10 percent.

- b) *Adobe pouring construction* — In this system earth is compacted to an extent that the air gaps are eliminated, bulk density is considerably increased and the tendency of development of cracks and to absorb water is reduced. Adhesion of soil particles with one another increases the mechanical strength and improved water resistant, requiring no surface treatment. The ratio of wall thickness to the wall height should be between 1 : 8 and 1 : 12. Symmetrical and geometrical forms are preferred in use of this material.
- c) *Compressed earth blocks (CEB)* — In this type of construction, blocks are manufactured by compacting raw earth using stabilizer such as cement or lime. Compressed earth blocks are generally cuboidal in shape and can be made in solid, hollow or interlocked pattern. Thickness to height ratio of walls constructed

with CEB should not be greater than 1:16 and wall thickness not less than 200 mm. This kind of construction can bear load up to three stories. The appropriate particle size distribution of the soil is a critical factor in using these blocks and soil analysis is specially recommended before considering CEB construction. Natural earth plasters with natural additives can also be used on unstabilized walls. These blocks have high compressive strength and provide good thermal mass. CO₂ emission is nil in the production of these blocks, if produced by manual operated compression machines and very low in case of other machines.

- d) *Soil based building blocks* — These blocks with appropriate combination of soil, cement, lime and possibly flyash (say 5 percent cement: 15 percent fly ash: 80 percent locally available soil) are cost effective and environmentally sustainable material. While in general building construction, soil based blocks may be used as a substitute for bricks, their use should be avoided in the case of isolated load bearing columns, piers and such other heavily loaded structures. These may be made in accordance with the accepted standard [11(10)].

9.2.1.3.2 Cob walls

Cob walls are a traditional system of wall construction done with soil along with sufficient clay, rough sand, small stones, straw and water. Cob when formed as one mass is called monolithic adobe. Cob is suitable for construction wherever there is sufficient clay in soil/sand (preferably 30 percent). Dug out earth during construction can also be used for construction of cob walls. Unlike adobe brick buildings, cob walls do not require mortar joints, and therefore provide additional strength to the building. Plastering can be done in a 1 : 3 (lime : sand), for exterior and interior finishes.

Cob wall has good thermal mass properties, is fire resistant; can be integrated with other materials such as straw, light clay, timber frame, adobe, conventional wooden-framed structure; and can be easily moulded into any form.

9.2.1.4 Stone

Stone is a durable and abundant resource. It has much lower embodied energy as compared to brick and concrete as it is natural material and hence requires much less energy in processing. Stone is good in compressive strength but low in tensile strength. It is used as masonry, cladding, and flooring. Stone aggregates are used in concrete mixes. However, mining

(quarrying) for stone may cause natural habitat destruction, deforestation and pollution.

Sustainable methodology should be the use of locally available (excavated) and undressed stone to the maximum possible extent subject to compliance to the environmental rules/regulations relating to its mining, etc.

For quality requirements of stones, reference shall be made to Part 5 'Building Materials' of the Code.

9.2.1.5 Timber

Timber is a building material which is used for structural as well as non-structural applications. It is a material with low embodied energy, is renewable, reusable, versatile, as well as varied in colour, pattern, grain, durability and strength. It is reusable and convertible into other sizes, and has a long life in indoor applications. Due to such properties of timber, its use may be desirable. However, over-harvesting of timber leads to adverse environmental effects such as natural habitat destruction, reduction in oxygen generation, soil erosion and silting of rivers. It is recommended to use timber harvested from sustainably managed forests or social/agro-forestry plantations or reclaimed (salvaged) timber. Secondary species of timber after proper treatment may be used for relevant applications. Timber should be properly seasoned and preservative treated. Timber is prone to fire, moisture ingress and termite and other insect attack. Therefore appropriate treatment is required with least amount of toxic and chemical content, depending upon the end applications. The seasoning and treatment of timber shall be done in accordance with the good practices [11(11)]. For structural timber small dimensional timber from saw milling waste and forestry waste can be utilised for the design of built-up structural components.

Reconstituted wood products are high in embodied energy (due to manufacturing process involved) as well as have toxic formaldehyde contents. However, these products can be considered due to high waste utilization benefits. Prefer using such products that have lower formaldehyde emission.

Use of techniques, like finger jointing which enables utilization of smaller sized timber jointed together through this technique to yield desired larger pieces, may be employed.

For interior applications, use of reconstituted wood or other lignocellulosic panel products made from agricultural or industrial wastes (such as phosphogypsum, bagasse, cotton stalk, rice-husk, coir fibre, pine needles, sisal fibre and wood residues) should be preferred. For partitioning, panelling, cladding, false-ceiling applications and flooring, the appropriate reconstituted wood or other panel products such as

plywood, block boards, particle boards, fibre boards, etc, made from secondary species of wood or plantation timber or from other lignocellulosic ingredients may be used. Reference may be made to accepted standards [11(12)] for compliance and for criteria for making such products eligible to apply for Eco-Mark Certification in accordance with the provisions laid down in these standards.

9.2.1.6 Plastics

Plastics are highly refined petroleum products. Plastics are materials with very high embodied energy, are non-biodegradable and may release harmful toxic gases during manufacturing processes or if burnt. Their disposal is a major problem yet, due to its light weight and flexibility, plastic has become a widely used material. It has various applications in the exteriors and interiors of buildings. The plastics are majorly used as insulation and as water proofing material [see 9.2.4.1.1(e)]. UPVC (unplasticized polyvinyl chloride) window frames are also used for their light weight and thermal properties [see 9.2.3.2]. The following recommendations may be considered from sustainability point of view:

- a) Use of plastics should be limited as far as possible or preference given to plastic products made with recycled content or renewable resources.
- b) Natural and renewable insulation materials should be preferred over plastic based insulation material.
- c) If required to be used for interiors, flooring, furniture and partitions products made with recyclable plastics should be preferred.

Other options where plastics may be used for appropriate applications, may be:

- 1) *Rice husk plastic wood* — It may be used in door and window frames, furniture and structural supports as it is moisture and termite resistant, highly workable, and meets the requirements of structural timber.
- 2) *Natural fibre composite panels and door shutters* — These are composites of natural fibres in laminate, faced on plastic wood.
- 3) *Fibre-reinforced plastic (FRP)* — These are used to strengthen building components structural members for rehabilitation purposes.

9.2.1.7 Metals

Metals are recyclable, reusable, very durable, light-weight and can easily be moulded into any shape and form. Metals have limited reserves and very high

embodied energy due to high consumption of energy to extract metals from its ore. All metals and metal alloys can in principle be recycled and reused. Through recycling of steel, copper, zinc and lead from waste, energy consumption can be reduced by substantially. The metal can be added to new processes in varying proportions, depending upon the end product and its quality requirements.

Steel and aluminium are the two maximum used materials in buildings, followed by brass as (building hardware), zinc and copper (cladding and electrical cables). Steel is used mainly as reinforcement material in concrete or as structural member in steel buildings. Steel building can be dismantled and reused easily unlike concrete. Steel buildings are more earthquake resistant and preferred in earthquake prone areas rather than concrete/masonry buildings. Steel sheets are used for roofing, walls and accessories. Aluminium is used in applications such as, door and window frames, cladding, and roofing sheets. The following recommendations may be considered from sustainability point of view:

- a) Use salvaged metal sections as far as possible.
- b) Use scrap steel and aluminium for non-structural applications.
- c) Use metals with verified recycled content.

The recycled content of metals varies with the type of furnace used for processing. With electric arc furnace the recycled content can be as high as 90-100 percent, whereas with BOF (basic oxygen furnace) it is about 30 percent. Where feasible, bolted sections should be preferred instead of welded as it helps in reusing the metal sections later; and the sections used should be light-weight, efficient and well designed.

Iron, aluminium, magnesium and titanium can be considered abundant and relatively benign metals, with high recycle potential, even if the environmental consequences of their extraction and production are quite severe. Steel is easy to recover and recycle. Steel with zinc coating or zinc and aluminium alloy increase strength and life of the structure. Virgin chrome, nickel, copper and zinc, however, should be used very sparingly or not at all as natural resources are limited. Copper, nickel and tin can be reclaimed from alloys in which they are the main component. The use of mercury, cadmium and lead should be highly restricted because of their high toxicity. All metals in the long term should be kept within closed cycles, in order to minimise their loss during production or during the life cycle of the building.

9.2.1.8 *Bamboo*

As an enduring, versatile renewable resource having low embodied energy, bamboo can contribute to

sustainable developments and poverty alleviations. It provides healthier environment by sequestration of carbon.

As a building material, it had been abundantly used in the country for traditional huts and hermitages for long besides as scaffolds. With the understanding of its physical and mechanical properties, it has been recognized as an engineering material with scope of designing and constructing moderate houses and other buildings and structures to sustain among others the lateral forces including earthquake forces, etc. Bamboo can be used as structural material in buildings in accordance with Part 6 'Structural Design, Section 3 Timber and Bamboo, Subsection 3B Bamboo' and Part 7 'Construction Management, Practices and Safety' of the Code. Bamboo can replace reinforced steel in tensile zone in certain applications and within limitations. Bamboo-jute composite panels, bamboo boards, bamboo lathe based partitions, flooring boards are also products which can be used for sustainable constructions.

9.2.1.9 *Mortar*

Mortar is a material used to bind as well as to fill the gaps between the bricks or blocks used in masonry construction. Mortar is a mixture of sand, a binder such as cement or lime, and water and is applied as a paste which then sets and hardens. The options available may be:

- a) *Lime mortar* — Lime mortar is mixture of sand, slaked lime and water. This kind of lime mortar, sets very slowly. The speed of setting of mortar can be increased by using impure limestones in the kiln, or a pozzolanic material such as calcined clay. Bricks bonded with hydraulic lime can usually be re-used. Lime mortar is easily workable and when hardened is less brittle and rigid than cement mortar, minimizing the problems of cracks. Hydraulic lime mortar is porous, permeable and thus moisture regulating. Lime mortar is produced at lower temperatures than cement and therefore requires less energy resulting in 20 percent less CO₂ emission.
- b) *Cement mortar* — Portland cement mortar is a mixture of Portland cement, with sand and water. Cement mortar is stronger and more impermeable than lime mortar and is therefore more commonly used for construction of load bearing masonry walls. However, manufacturing of cement is one of the major causes of the greenhouse gas emission. Such mortars having as large replacement of Portland cement as possible by alternative but effective materials, is desirable. For this, use of Portland pozzolana cement or Portland slag

cement in place of Portland cement in the mortar shall be preferred.

- c) *Mud mortar* — Mud mortar is prepared by simply mixing soil with water until it is in a plastic (workable) state. Once applied, a mud mortar sets quite rapidly on drying without the need for curing. The beneficial characteristics of mud mortars including good bond to compatible surfaces and ease of preparation allow them to be used in a range of applications such as cob walls, adobe blocks in wall construction, masonry, monolithic walls, and even in flat roofs. However, it has low tensile strength and is subject to shrinkage that causes large number of micro-cracks in the mortar reducing its bond strength and the strength of the whole structure. In addition, mud mortars are liable to increased erosion and loss in strength, if used in humid or wet conditions. Performance of mud mortars can be improved with various additives such as straw to reduce the shrinkage and cement to increase bond strength (but increases structural cracks which can be compensated for by inserting shrinkage joints).
- d) *Lime sand mortar* — Lime sand mortars are a blend of sand and lime to which cement and water is added on site. Cement helps to give mortar early strength and durability, lime helps to achieve greater strength and elasticity over time, and sand acts as an inexpensive filler.
- e) *Lime pozzolana mortar* — The pozzolana traditionally used in the country is *Surkhi* (made by burning clayey soils in a field kiln). Such mortar may be weaker than Portland cement mortar but has better waterproofing properties and has been widely used in dam construction. The use of reactive rice husk as super pozzolana is also a resource efficient option. Combination of burnt clay and rice husk can also be used as pozzolana. Flyash can also be used in the preparation of lime-pozzolana mortar. Mixture of lime-fly ash-sand with 5 percent addition of calcined gypsum can lead to good quality mortars.

NOTE — There are other technologies and materials available locally which use no cement and use flyash and binding agents. These options may be used if performance parameters are met.

For preparation and use of masonry mortars other than mud mortar, reference may be made to good practices [11(13)] and for mud mortar to good practice [11(14)].

9.2.1.10 Glass

See 9.2.3.1.

9.2.2 Surface Materials

9.2.2.1 Floor and floor coverings

Stones, ceramic tiles, vitrified tiles, bamboo, linoleum, terrazzo, metal tiles, recycled or reclaimed wood and floorings with high recycled content may be some eco-friendly materials, if used with due consideration to sustainability. Following are recommendations on use of various floor covering materials which may replace conventional materials:

- a) *Finish concrete flooring* — Concrete floor is highly durable, low in maintenance and can cope with water and chemicals. This flooring can be a resource efficient option where the main slab is finished with topping layer of concrete admixed with colourants and sealers. The finishing layer should be stamped with patterns and grid lines to prevent cracks and for improved appearance. Water dispersed acrylic sealers having lower VOC may also be used.
- b) *Resilient flooring (bamboo and linoleum flooring)* — Bamboo is a natural, renewable, hard wearing and economical option for flooring. Bamboo flooring can be of solid bamboo (made with only bamboo) or bamboo mat board with or without wood veneers. Linoleum flooring is made with reusable and natural occurring material like cork, linseed oil, wooden flour and pine resin. Both the flooring materials require frequent maintenance and can cause indoor pollution if they are VCT (vinyl composition tile) or polyvinyl tile sheet based (release toxic materials in their production). See accepted standard and good practices [11(15)] for linoleum flooring.
- c) *Terrazzo in-situ flooring and tiles* — These tiles may contain up to 60 percent recycled content (crushed stones) mixed with cement. It is a low embodied energy, inert and highly durable and low maintenance flooring. Adhesive used for tiles laying should be of low VOC, non-toxic in nature. Cement mortars with acrylic additives are the better options for adhesive. See accepted standards and good practices [11(16)].
- d) *Ceramic/vitrified tiles* — These are durable, have low maintenance requirement and can have high recycled content (clay mixed with up to 95 percent recycled content like recycled glass and crushed stone and feldspar), and are water resistant and may also be recyclable depending upon the pigments added. Ceramic and vitrified tiles have higher embodied energy as compared to terrazzo tiles as there

is firing process involved in their manufacturing. Also, these tiles may have pigments (metal oxides), many of which are environmental pollutants, hence rules for proper disposal need to be followed. Low VOC and non-toxic option for adhesive for laying these tiles should be used. Cement mortar with acrylic additives is most suitable and safer option. See accepted standard [11(17)].

- e) *Wooden flooring* — Timber or reconstituted panel products used for manufacture of wooden flooring shall comply with 9.2.1.5. For protective coating of these products water dispersed urethanes having low VOC (than solvent based), and not having toxic urea formaldehyde should be used. Use of acid cured varnishes and low VOC adhesive is preferred. Finishing of these materials (laminated, veneer or coatings) shall also be of low VOC.
- f) *Stone* — Limestone, marbles, granites are some common stones that last longer than the manufactured tiles. See 9.2.1.4 for stone properties and sustainable alternative.

9.2.2.2 External and internal wall finishes

Selection of materials for external wall finishing is important as it affects the thermal and acoustic insulation of the building and materials for internal wall have effect on indoor air quality (IAQ). Following are recommendations from sustainability point of view:

- a) *Plaster* — Plaster not only acts as a protective covering over walls and provide finishing, but also plays important role in indoor environmental quality of building. There are several alternatives in plaster available, depending on the surface to be plastered, climate of the place, elasticity, etc. The usual binders are lime, cement and gypsum or the mixtures of these substances. Fibre, mineral fibre, perlite, hacked straw, or even hair from cow, pig and horse are sometimes added for better binding, elasticity and/or insulation. Pigments, if added are generally metallic oxides, which should be fine grained and calciferous. For external plastering or plastering in rooms such as bathrooms, water proofing agents are sometimes added to plaster. The grain size of sand in plaster shall depend on the surface quality required and layers of plasters to be used. The raw material availability of the different component of plaster is generally good. Lime and gypsum based products have good moisture regulating

properties. Waste of lime and cement based plaster, being inert can be used as fill. Pure lime plaster can be ground up and used to improve the soil. Dumping sulphur and gypsum waste can lead to sulphur pollution which can be reduced by adding lime. Features of various plasters having effect on sustainability are as follows:

- 1) *Lime plaster* — It is a very old and sustainable method of plastering which require higher degree of skill for good quality work. It is composed of lime, sand and water and is also suitable for use with clayey soils (lime: soil should be between 1:10 and 1:5). In the making of lime-pozzolana plaster, *Surkhi* (made by grinding waste bricks to fine powder), fly ash or reactive rice husk ash can be used in lime mortar. Lime can also be obtained from fertilizer industry (as an industrial waste). Lime plasters have low VOC and have approximately 25 to 28 percent lower carbon dioxide emissions, have lower embodied energy and can contain 50 to 65 percent post-industrial use recycled content. It has wide applicability in restoration of heritage buildings. It is most suitable for internal use but can also be used externally. However, for external use it should be protected against driving rain and continuous dampness, otherwise it may get damaged due to its high porosity. For external use, lime to sand ratio of 1:3 should be used. Lime plaster helps the walls to retain their moisture regulatory properties.
- 2) *Cement plaster* — This is mostly used as an external plaster and can be used on brick masonry, solid concrete walls, concrete block masonry, stone masonry, etc. For internal plaster, the proportions can be 1:6 (cement: sand), whereas for external use they may vary between 1:3 and 1:4 (depending upon the surface to be plastered and the climatic conditions). For application of cement plaster, reference may be made to good practice [11(18)].
- 3) *Cement-lime plaster* — This plaster is used externally. It is somewhat stronger than lime plaster and more elastic than pure cement plaster. In cement-lime plaster, 30 to 50 percent of the binder is cement. For applications of cement-lime

plaster, reference may be made to good practice [11(18)].

- 4) *Gypsum plasters* — It is a dry mixture of gypsum and mineral fillers. Gypsum plastering is mainly for internal use especially as a moisture regulating layer, usually having a mix of one part of gypsum and two parts of sand. This mixture sets in 10 min to 30 min. Lime can be added to make the gypsum plaster usable for longer time. Gypsum is a natural mineral, has quality to absorb pollutant and can also be easily percent recycled completely. This plaster has good compressive strength, and thermal, acoustic and fire resistant properties. Gypsum can be obtained from either natural resources or it can be obtained as industrial by-product or as a product with recycled content. For materials for plaster, requirements and application, reference may be made to accepted standards and good practices [11(19)].
- 5) *Clay plaster* — Clay plaster is a natural, breathable material which is created by composing rocks and minerals, mixed with sand and water to create a workable mix for plastering. It is bio-degradable, absorbs odours, has good sound and thermal insulation properties, is fire resistant and has good temperature regulation properties. Plastering with clay is a quicker method than with traditional gypsum plastering. Long drying time means that it is workable for longer period. However, it is not as strong as other plasters in shear and compressive strength.
- 6) *Sulphur plaster* — This can be produced by melting sulphur at temperature from 120°C to 150°C. Sand, wood flour or the equivalent can be added. It has waterproofing properties but cannot be used over materials with high lime content.
- b) *Mineral and fibre based sheeting/boards* — There are three main types of mineral based sheeting: cement based, calcium silicate based and gypsum based. Raw materials for all the three are abundant. Apart from the binder, they contain fibrous reinforcement. When they are mounted, the joints should be filled with filling material based on plastic binders, mainly PVAC glue or acrylate glue. Production of these sheets is relatively low in pollution.

Calcium silicate and gypsum products are also good moisture regulators. Features of such boards having effect of sustainability are as follows:

- 1) *Fibre cement sheets/boards* — These are suitable for all modern and conventional constructions for both internal and external uses as they have high resistance against moisture, fire and termite. It may contain up to 35 percent fly ash and 5 percent recycled pulp and other recycled content, has a long life span, requires little maintenance and is economical. High embodied energy in its creation is compensated by the use of fly ash and recyclable waste. For requirements for some of these sheets reference may be made to accepted standards [11(20)].
- 2) *Calcium silicate sheet* — These can be used as both internal and external cladding. The sheeting is produced with up to 92 percent by mass of quartz mixed with lime and cellulose fibre. Vermiculite can be used as aggregate. Calcium silicate products can be crushed and recycled as aggregate in concrete. If it is finely ground it can be used in mortars and plaster. The waste is inert and can be used as fill.
- 3) *Gypsum plaster board* — These boards are manufactured from 95 percent gypsum with possible addition of fibreglass reinforcement (about 0.1 percent by mass). The substances such as calcium lignosulphate, ammonium sulphate and an organic retardant may also be added to a total of about 1 percent by mass. Pure gypsum sheeting is not too strong; hence, some lime and a large percentage of wood shavings are added to increase strength. The sheeting products are used mainly for internal cladding, and may be covered by wall papers or thin fibreglass woven sheeting for painting. Pure gypsum plaster board is too weak to be dismantled and re-used but it can be broken and recycled and used as 5-15 percent of raw material. However, since gypsum industry is very centralized, it makes it uneconomical to recycle. See 9.2.2.2 (a) (4) for properties of gypsum plaster. For requirement and use of different gypsum plaster boards and material for their manufacture, reference may be made to accepted standards [11(21)].

- c) *Grit wash* — This finish uses waste stone pieces and aggregates like marbles, granites, stones mixed with cement, etc. This is a permanent finish requiring less maintenance.
- d) *Paints and coating* — Generally paints and coatings contain large quantity of VOC and create pollution indoors as well as outdoors (due to release of volatiles by oxidation of both solvent and water based paints). Water based acrylic paints are better option over solvent based oil paints because of durability and lower toxic release. Paints made from natural raw ingredients such as milk protein, minerals, bee wax, natural wax, lime, chalk, talcum, earth and clay pigments and plant oils and resins, should be preferred as they have little to no smell and low VOCs.
- e) *Timber* — See 9.2.1.5.
- f) *Stone cladding* — Stones can also be used as external wall finishes. However, stone fixing has to be carefully considered for high seismic zone and high rises.
- g) *Metal composite panels (MCP)* — These are formed by bonding two metal skins to a highly engineered plastic core placed between them, creating a sandwich panel. The bonding process occurs under very precise conditions of temperature, pressure and tension resulting in a metal/plastic composite sheet. MCP is used for cladding of building exteriors, entryways, canopies, soffits and facias. Metal skins may be of aluminum, zinc, copper, stainless steel, and titanium. MCPs can be finished in different colours. MCPs are flexible, durable, light weight and easy to install and maintain, weather proof and flexible with low emissivity and high reflectance. MCP shall be fire resistant, which can be achieved by using a fire resistant core in the sandwich construction.
MCPs having high percentage of recycled content and made out of reused plastic core should be preferred.
- h) *Wallpapers* — Wallpapers are for internal use. Wallpapers like grass cloth wall paper, bamboo wallpaper and jute wallpaper are some eco-friendly biodegradable wallpapers. The grass cloth wallpaper is hand-made from woven natural grasses and therefore is sustainable and manufactured from renewable resources.

9.2.3 Building Fenestration and Detailing

9.2.3.1 Glazing

Glass is a high embodied energy mineral material. Its

usage is in skylights, windows, glazing systems, flooring, infill panels for doors. Glass helps to get in natural daylight to interior spaces and provides views. Glazing, if not chosen and positioned in a building properly, may lead to lot of heat ingress/egress.

Glass shall be selected with high recycled content and shall be so sized as to minimise wastages. Use of glazing in fenestration shall be in accordance with 8.1.3.

9.2.3.2 Door and window frames

Frames made of stone, wood, steel, aluminium, reinforced concrete and UPVC are generally used for building construction. Use of stone frame should be preferred in the area where they are locally available as they provide an economical, durable, and termite proof frame. Likewise precast RCC door/window frames are another durable, economical and termite proof alternative. Wooden frames provide better insulation than metal frames. Metal frame although recommended for its durability, high recyclability, light weight and for larger spans, has high heat conductivity. Metal frames are required to be detailed with thermal break (low conductive material) to reduce their conductivity. Frames of plastic and aluminium can be made of profiles filled with foamed insulation of polyurethane to offset high heat conductivity. Composite products are now being available which use either aluminium with UPVC or timber with aluminium, where timber is the insulating material. Inferior quality timber can be used in that case, as the outer layer of aluminium provides weather protection to the same.

Plastic windows are usually made of unplasticized polyvinyl chloride (UPVC) stabilized by cadmium, lead and tin compounds and added colour pigments. All these products have very limited reserves, and cause high level of pollution during processing.

The manufacture of an aluminium and UPVC door and window frame uses very high energy input than a timber/RCC door/window frames. Both UPVC and aluminium windows can be reused if they are initially installed for easy dismantling. Pure aluminium frames can be recycled. Special precautions should be taken to dispose of wastes which contain cadmium, lead or tin. Considerations given in 9.2.1.6 may be followed.

Defective doors of solid timber can usually be recycled or composted but laminated products should be disposed of with special precautions or recycled in incinerators that filter the fume. Considerations given in 9.2.1.5 may be followed for selection of timber for frames. For requirements of wooden frames including such frames eligible for Certification for Eco-Marking, reference may be made to accepted standard [11(22)]. Depending upon the availability or otherwise of various alternatives and their suitability for sustainable

considerations, use of precast reinforced concrete door and window frames may be considered as they are highly durable and also eligible for Eco-marking; for quality requirements of this frame, reference may be made to accepted standard [11(23)].

Sealing of frames should be done in accordance with **8.1.3.2.2**.

9.2.4 Climatic Control Materials

Climatic changes is the prime factor affecting longevity of the building, maintenance of a safe and eco-friendly environment and durability of building materials. There are several historic buildings which have existed for centuries due to the reason that they were built with durable materials to withstand different climatic conditions of the places in which these were built. These materials can be used for climate responsive designs as well as for reducing the harmful impact on environment.

9.2.4.1 Thermal insulation materials

The thermal insulation of walls and roof shall be done in accordance with **8.1.1** and **8.1.2**. Thermal insulation materials are used for making a building resistant to heat ingress and egress. A thermal insulator is a poor conductor of heat and has low thermal conductivity. Thermal resistance, thermal conductivity, thermal transmittance, stability, density of materials, long life, fire resistance, lack of odour, low chemical activity, ability to cope with moisture and good thermal resistance are some factors which have to be considered in selecting materials for thermal insulation.

9.2.4.1.1 Types of thermal insulation materials

Insulation materials may be divided into organic and non-organic groups (mineral fibres, glass wool, perlites) according to their raw materials. Organic materials can be subdivided into more environmental friendly for example natural materials (cork, cotton and wool) and less environment friendly for example synthetic materials (polyurethane rigid foam and polystyrene). Some thermal insulation material may be reflective and some high in embodied energy, which may get offset by saving in the operational energy of the building over their life span.

- a) *Mineral wool* — Mineral wool products are light and have extremely good thermal insulation values. When used as insulation both glass and rock wool need a barrier of suitable material sheeting, partly to avoid dust and partly because the material cannot regulate moisture as required. Exposure to mineral wool fibres may cause skin problems, itching, eye damage and respiratory irritation. Raw materials are abundant for the main

constituents of glass wool and rock wool. The production of glass wool occurs in relatively closed processes where emissions are little and limited to formaldehyde and dust. Large amounts of phenol, ammonia, formaldehyde and dust are released during the production of rock wool, and large amounts of wastes are produced. For requirements of bonded mineral wool, reference may be made to accepted standard [11(24)].

- 1) *Glass wool* — Made from silica sand, limestone, boron, recycled glass (approximately 70 percent), phenol formaldehyde resin or acrylic resin, it is a lightweight and fire resistant insulation material commonly used for duct and wall insulation. Glass wool is a high embodied energy product as glass is melted at higher temperature to make the fibre. Glass wool is easily recyclable and possesses good acoustic insulation properties.
- 2) *Rock wool* — It is a light weight high embodied energy and fire resistant product, made from natural rock basalt primarily under high heat. It is denser than glass wool and *R*-value is higher than glass wool. Rock wool may contain 10 percent recycled content in the form of building waste and 15 percent recycled content from waste from industry (slag from the steel production process). For requirements, reference may be made to accepted standard [11(25)].
- 3) *Cotton* — This is a rapidly renewable product made from both natural fibres as well as industrial waste from recycled cotton textiles. Cotton is also a good sound insulator, requires little energy to manufacture as well as is non-toxic. Waste cotton, a high water absorbing material should be protected by moisture/vapour barrier.
- 4) *Natural wool* — It is made with recyclable and renewable source and is non-toxic and bio-degradable. It does not contain any synthetic fibres but has a disadvantage that it absorbs VOC.
- b) *Cellulose fibres* — These can have very high recycled content and can be made from waste papers (about 90 percent recycled papers) or pulverized pulp and are cost-effective. They can also be made from different types of cellulosic materials like card boards, waste papers, old newspapers, cotton, straw, saw dust and hemp. These fibres have very low

embodied energy, but they need to be treated for fire retardance (such as by boric acid). This product may be reused and recycled but should not be incinerated.

- c) *Plastic* — Many plastics have good water-proofing and high thermal insulation properties (when produced as foam). As a sealant, plastic can take many forms such as paint, sheeting, paper, sealing strips and mastics. The materials are foamed up using chlorofluorocarbons and carbon dioxide, and fire retardants and stabilizers are added. It is recommended to use products which do not use CFCs or HCFCs as blowing agents during manufacturing. Depending upon how the materials are built in, polystyrene can emit extra monomers of styrene while polyurethane can release small amounts or unreacted isocyanates and amines. Ashes from the furnaces and plastic waste which is not recycled needs to be disposed of safely to prevent seepage into the groundwater or soil. Properties of polystyrene are as follows:
- 1) *Extruded polystyrene* — This material has very high *R*-value per unit thickness, good moisture resistance, and high compressive strength and is light in weight. It is commonly used in wall and roof insulation.
 - 2) *Expanded polystyrene* — It is a light weight and has high *R*-value, but it has low compressive strength and is not moisture resistant.
 - 3) *Closed cell flexible elastomeric foams* — These naturally resist ingress of water vapour, help in long term efficiency of the insulation and minimise chances of condensation and increased heat gain over a period of time.
- d) *Autoclaved aerated (cellular) concrete blocks* — See 9.2.1.1(f)(2).
- e) *Preformed foam cellular concrete blocks* — See 9.2.1.1(f)(4). These have better water resistance.
- f) *Hollow concrete block* — See 9.2.1.1(f)(1).
- g) *Reflective Insulation materials* — These comprise highly reflective materials like aluminium foil. It may retard the heat transfer up to 97 percent. It is very effective in warmer climates, requires less area, acts as a vapour barrier also, and is non-toxic. However, it has less compressive strength and requires some backing support.
- h) *Perlite and pumice products* — Perlite is a natural glass of volcanic origin. It is pulverized and expanded in rotating kilns at about 900°C to 1 200°C, which increases its volume from five to twenty times. It is used either as loose fill insulation or as aggregates in mortar and light weight concrete blocks. Perlite absorbs water, hence moisture preventive materials like bitumen or silicon are sometimes added. It can be used for thermal insulation of buildings, refrigerating rooms and high temperature insulations.
- j) *Vermiculite products* — Vermiculite is formed through the disintegration of mica, which liberates lime and takes up water. When vermiculite is heated to 800°C to 1 100°C, it swells to become a light porous mass which can be used as an independent loose insulation or as an aggregate in a lightweight concrete in the proportion of 6 : 1 (vermiculite to cement). Prefabricated slabs can be made in varying thickness from 15 mm to 100 mm using this material. Vermiculite is useful for high temperature areas and equipment. It easily absorbs large amount of moisture, even more than untreated perlite. As normal wall insulation, it has a tendency to settle, hence needs to be compressed substantially after filling into the wall cavity.
- k) *Saw dust and wood shavings* — They are wastes from timber industry or carpentry, and can be used for thermal insulation in walls or ceilings. Saw dust has hygroscopic property due to which it easily absorbs moisture, and then releases it in air and therefore is moisture regulating. Saw dust and wood shavings are chemically inert, non-toxic. However, they are not fire resistant, and the same can be improved by adding pulverized clay.
- m) *Traditional techniques* — Following vernacular techniques have generally been used effectively for thermal insulation of building in the country:
- 1) *Straw-bale insulation* — Straw bale walls (bales of straw commonly of wheat, rice, rye and oats which are agricultural wastes after harvesting) have good thermal insulation properties. These should be packed tightly for improving fire resistance. Straw bale is biodegradable, low embodied energy, non-toxic, easily available, cost effective and rapidly renewable product. These walls are porous in nature hence exposed walls require protection from rain in the form of plaster (generally lime plaster) and deep eaves/verandas.

- 2) *Inverted earthen pot insulation* — Shading the roof top with inverted earthen pot is an easy and cost effective method to reduce solar gain. In this method roof is covered by inverted earthen pots, the top of earthen pot can be covered with a layer of earth or lime mortar finish or can be left uncovered. By virtue of air trapped within them they provide good insulation. Earthen pots painted with white paints further reduce the heat load. Pots made with earth are recyclable and locally/regionally available.
- 3) *Brick bat coba* — This system involves laying mortar with broken brick (which may be waste brick pieces) as aggregates and ground brick with lime or cement as binding matrix. A thick mass of brick bats provide the thermal insulation for roof of the building.
- 4) *Mud phuska* — For this, good quality earth suitable for brick making not containing excessive clay or sand, free from stones, *Kankar*, vegetable matter and other foreign matter should be used. In this system a layer of puddled mud is mixed with grass straw applied on a sand-bitumen waterproofing layer which is then consolidated and plastered with cow-dung mortar. Tile bricks are laid flat on plastered surface and the joints are grouted with cement mortar. All materials are readily available, economical and non-toxic. Laying of mud *phuska* shall be done in accordance with the good practice [11(26)].
- n) *Broken ceramic mosaic tiles* — Broken ceramic tiles can be used as a cost effective external roof finish to reflect the incident solar radiation. Broken ceramic light-coloured tiles reflect heat off the surface because of high solar reflectivity and effectively utilize the waste ceramic tiles.
- p) *Cavity wall insulation* — Cavity wall consists of two layers of masonry separated by a hollow space that work as a thermal insulation as well as provide better sound insulation. Cavity wall made with fly ash blended cement concrete blocks or blocks with high recycled content or internal wall with under burnt clay bricks makes it more environmental friendly. Hollow space between the two walls can be filled with the insulation materials. Rat trap bond is a cavity wall construction technique with added advantage of economy in brick use (of about 25 percent). However, these walls occupy more floor area.
- q) *Poured in-situ cellular light weight concrete* — This work to be done in accordance with accepted standard [11(32)].
- r) *High SRI Paints* — The recent development has been the use highly thermal reflective paints for the exposed terrace areas which reflects incident heat and adds to the insulation values.
- 9.2.4.1.2 Covering or finishing materials for thermal insulation**
- These are used to protect and help to elongate the life and usefulness of the insulation from weather, water vapour condensation, and chemical attack and sometimes even from fire. Additionally, appearance coverings are utilized to provide the desired aesthetics. These may include:
- a) *Weather barriers* — These should be installed on the outer surface of thermal insulation to protect the insulation from the weather such as rain, snow, sleet, dew, wind, solar radiation, atmospheric contamination and mechanical damage. Metals, plastics, paints and coatings and roofing felt are few weather barriers.
- b) *Vapour retarders* — These are materials which retard the passage of moisture or vapour into the insulation. Laminated foil-scrim membranes and metal and plastic sheets are vapour retarders.
- 9.2.4.2 Moisture and air regulating materials**
- Moisture and air regulation in sustainable building is essential to get better indoor environmental quality as well as to protect building and building components from damage. Insulation and other components aimed at controlling seepage of moisture and air to and from building shall be included in the building envelope design. Common air sealing materials include caulks, expanding foams, weather-stripping of doors and windows, gaskets, door sweeps. Another environment friendly technique is to use high recyclable moisture regulating materials like adobe brick and mud construction.
- 9.2.4.3 Water proofing materials**
- Water proofing materials resist liquid water passing through, but may allow water vapour to pass through. They can be categorized on the basis of application (cold applied or injection type) or on the basis of their types or state (layer type or fluid type).
- a) *Cement based waterproofing products* — These are suitable for both negative and

positive water pressures. They contain no solvent. They are however low on elasticity and prone to cracking.

- b) *Plastic-polymer products* — Plastic-polymers have good water proofing properties and have been successfully used due to their light weight, elasticity and non-porous nature. However, there are major limitations from sustainability point of view in using plastic products (see 9.2.1.6). Some examples are coal-tar, bitumen, ethylene propylene diene monomer (EPDM), polyurethane and PVC, which are briefly described below:
- 1) *Polymer modified bitumen* — These are available as hot/cold applied fluid products and as sheet membranes.
 - 2) *Polyurethanes/urethane membranes* — These are typically fluid-applied and remain elastomeric (flexible) throughout their useful life. This group of waterproofing membrane materials is commonly referred to as fluid-applied elastomers.
 - 3) *Thermoplastics (PVC) waterproofing membranes* — These are available in sheet forms and are typically applied with heat-welded seams.
 - 4) *Asphaltic membranes* — These typically consist of emulsified (liquid) asphalt and reinforcing fabric, fibreglass or organic, and are applied in layers.
- c) *Brick bat coba* — It provides waterproofing up to some extent. Brick bats coba may be made cost effective by using waste generated during construction or demolition. It works more efficiently if used in combination with other water proofing material. The disadvantages of using brick bat coba are increase in dead load on slab as well as thickness as compared to other water proofing materials [see also 9.2.4.1.1(m)(3)].
- d) *Bentonite clay* — Bentonite is sedimentary clay composed of weathered and aged volcanic ash. It has the capacity of quickly absorbing large amounts of water and swelling to many times in volume. When the surroundings dry out again, the clay releases its moisture. It is useful as an absorbent waterproof membrane on foundations and foundation walls made of brick and concrete. It is available in rigid, flexible and granular form.
- e) *Other waterproofing membrane materials* — These may be materials such as butyl rubber, crystalline and cementations products.

Besides, there are some eco-friendly organo-silicone products based on nanotechnologies which also work as waterproofing materials.

9.3 Construction Phase Material Storage and Handling

It is essential for construction industry to have proper material handling and storage to provide a continuous flow of materials and components and ensure that materials are available when needed and to avoid wastage. For storage and withdrawal of construction materials from storage places, first in first out policy should be followed. Care has to be taken in storing moisture sensitive construction phase materials like cement, Plaster of Paris (POP), gypsum board, wood and other lignocellulosic materials based products, as well as steel components/materials which may get corroded in the presence of moisture. Inflammable, volatile materials may need proper segregated storage. There may be some materials or components which require to be so stored/stacked as to avoid undue stress over them and ensure safety of the personnel. For guidance on proper stacking and storage of building materials, a reference may be made to good practices [11(27)].

9.3.1 Handling of Materials and Equipment

Handling materials involves diverse operations of crane, truck and manual handling. The efficient handling and storing of materials is vital considering continuous flow through the workplace, and availability. Improper handling may cause severe damages. The workers should be aware of the potentiality of the injuries and hazards due to unsafe or improper handling. During mechanical shifting of materials, one should avoid overloading the equipment.

To reduce potential accidents associated with workplace equipment, employees need to be trained about the proper use and limitations of the equipment. The operating manuals of major handling equipment, for example, conveyors, cranes, slings and industrial trucks should be referred before using these equipment. Periodic inspection and checking of handling equipment should be carried out by the authorized persons only.

10 WATER AND WASTE MANAGEMENT

10.1 General

10.1.1 The country has been well endowed with large freshwater reserves. However, with the increasing population, industrial activity and pollution, surface and groundwater resources have been overexploited and severely polluted during the past few decades. As a result, the country is faced with immense water scarcity.

Growth of the country's economy is driving increased water usage across sectors. Waste water generation is increasing significantly and in the absence of proper measures for treatment and management, the existing freshwater reserves get polluted. Further, increased urbanization is driving an increase in per capita water consumption in towns and cities. Urbanization is also resulting in change in consumption patterns and increased demand for water-intensive agricultural crops and industrial products.

10.1.2 Significant liquid and solid waste generation is witnessed and recorded in the urban areas of the country. The municipal solid waste generation ranges from 0.25 to 0.66 kg/person/day with an average of 0.45 kg/person/day. In addition, large quantities of solid and liquid wastes are generated by industries. Unless properly managed, most of the wastes generated may find their way into land and water bodies, emitting gases resulting in bad odour and air pollution as well as increase in the emission of greenhouse gases. This problem can be significantly mitigated through adoption of treatment, recycling and processing before disposal, and adopting waste to energy technologies. It not only reduces the quantity of wastes, but also improves its quality to meet the required pollution control standards and regulations, besides generating substantial quantity of resources and energy [see also 11.16 (c)].

10.1.3 Sustainable approach to water and waste management requires planning and design of building functions to integrate issues of water and waste management system at the early stages of project evolution, their management during construction activity and subsequently during occupancy and use of building. At the scale of building complex or at township level, the opportunities for water efficiency and waste management are large particularly in respect of external development and landscaping (see 7.1.3). The sustainable approach should finally adopt an integrated approach to water supply, water waste and solid waste management aimed to create built facilities with zero anthropogenic waste design solution. Following are the broad aspects for achieving sustainable water and waste management:

- a) *Conceptualization, planning and design stage* — Water is essential to create liveable neighbourhoods and public spaces. The function of a water supply system is to provide water from a source identified through considered selection, treat the same to render it suitable for its intended use, and deliver it to the user at the time and in the quantity prescribed. Major considerations during planning and design include yield and quality

of raw water sources; topography, geology, population density of service areas; intended uses of water; and treatment of waste water. Since these considerations may vary from project to project, all water and waste management system solutions are unique.

Planning and design of water and waste management system needs a holistic approach. The system should integrate functions, water supply systems, waste water system (including grey water use), storm water management (including rainwater harvesting) and solid waste management and waste to energy systems. The complexity of holistic design process requires coordinated decision-making process.

- b) *Construction stage* — Objective of construction stage is to create the built facility. The concerns of efficient water use and waste have a potential to be ignored. It is essential to establish systems for water and waste management so that the project teams monitor water consumption, control wastes and disposal in an environmentally appropriate manner. The existing surface and groundwater resources should first be protected and suitability integrated in the building and layout plan. There is a scope for selection of materials and technologies, which are water efficient. Value engineering of material and technology selection should be undertaken so that the solutions are appropriate to the project peculiarities as well as environmental constraints. Construction, including in environmentally sensitive sites, necessitates compliance to legal and statutory requirements for water and waste management.
- c) *Performance during use and corrective action* — Building projects are planned, designed and executed in accordance with the anticipated functional use. However, it is reasonable to expect some variance during use. Building use is a dynamic process and functional use is constantly evolving during life of a building. Also, engineering system designs are optimum solutions based on assumptions, which can only be validated during actual use. Design of systems should be done within a considered tolerance of functional use. The performance of water consumption should be monitored during use and compared with the benchmarks (industry specific, building specific or established standards) given in the Code and corrective actions undertaken. In this respect, it is

important to design systems that facilitate monitoring. Appropriate metering and corrective improvements should be integrated in the system design detailing. It may be desirable to design water system taking functional homogeneity into account and facilitate function specific corrections in response to environmental considerations and opportunities for conservation.

10.2 Planning and Design of Water Management System

10.2.1 Planning and Design of Water Supply System

Planning and design process begins with use analysis for demand assessment, identification of project constraints and water sourcing. Inputs on these parameters are critical design brief contents. Hot water systems are energy intensive building component. Opportunities for waste recovery, temperature setting and selection of technologies that use clean fuels such as solar water heaters need to be included in the planning and design approach for hot water systems. While the systems may be designed efficiently, the strategies for water efficiency and conservation need to be built into the system design. Finally, system components need to be integrated as part of sustainable planning and design approach. Figure 16 gives a typical scheme showing general components of water management system. This shall also incorporate water requirements for fighting fire.

It is recommended that an overall water balance chart

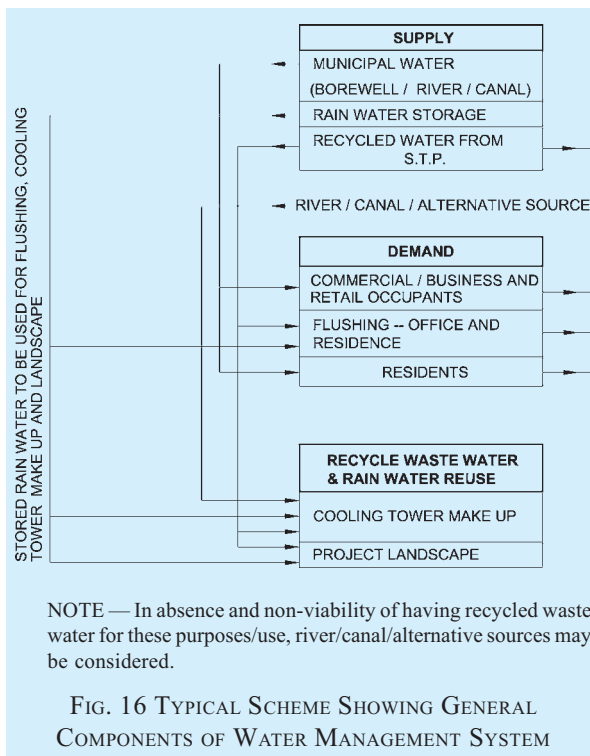

be prepared indicating all supply side resources, infusion of recycled water, and the actual consumption for potable and non-potable and other purposes. This chart should also indicate the extent of recycled water use for different consumption depending on the level of water treatment and reduction in freshwater intake through rainwater harvesting potential of the site.

A reasonably accurate estimate considering a calendar year long demand-supply assessment including demand fluctuations of the amount of water that should be supplied, is needed early in the planning stage of project development. The average daily demand is especially important since it may be used to assess the ability of available sources to meet continuing demands and to size raw water storage facilities that may be required to meet sustained demands during dry periods. Later, during the actual design process, the peak demand is required to properly size pumps and pipelines, estimate pressure losses, and determine water storage requirements so that it may be planned to store sufficient water and cater for daily water demand. Uses of water include agricultural, industrial, household, recreational and environmental activities. Its estimate for fire-safety purposes is also to be addressed in the design stage itself. Almost all of these human uses require freshwater.

10.2.1.1 Availability of water

The water availability and the associated features and constraints are as follows:

- a) *Surface water* — Surface water is water in river, lake or freshwater wetland. Surface water is naturally replenished by precipitation and naturally lost through discharge to the oceans, evaporation, evapotranspiration and sub-surface seepage. Although the only natural input to any surface water system is precipitation within its watershed, the total quantity of water in that system at any given time is also dependent on many other factors. These factors include storage capacity in lakes, wetlands and artificial reservoirs, the permeability of the soil beneath these storage bodies, the runoff characteristics of the land in the watershed, the timing of the precipitation and local evaporation rates. All these factors also affect the proportions of water lost.

Human activities can have a large impact on these factors. These often include increase in storage capacity by constructing reservoirs, decrease by reclaiming wetlands and increase in runoff quantities and velocities by paving areas and channelizing stream flow. Also, surface water may be lost (for example, become unusable) through pollution.

The total quantity of water available at any given time is an important consideration. Some users have an intermittent need for water. For example, many farms require large quantities of water in the spring, and very less or no water in the winter. To supply water to such a farm, a surface water system may require a large storage capacity to collect water throughout the year and release it in a short period of time. Other users have a continuous need for water, such as a power plant that requires water for cooling. To supply water to such a power plant, a surface water system needs enough storage capacity to fill in for use later when average stream flow is below the power plant's need. However, over a long term the average rate of precipitation within a watershed is the upper bound for average consumption of natural surface water from that watershed.

Natural surface water can be augmented by importing surface water from another watershed through a canal or pipeline. It can also be artificially augmented from any of the other sources; however in practice the quantities of such water are negligible.

- b) *Under river flow* — Throughout the course of the river, the total volume of water transported downstream will often be a combination of the visible free water flow together with a substantial contribution flowing through sub-surface rocks and gravels that underlie the river and its floodplain called the hyporheic zone. For many rivers in large valleys, this unseen component of flow may greatly exceed the visible flow. The hyporheic zone often forms a dynamic interface between surface water and groundwater, receiving water from the groundwater when aquifers are fully charged and contributing water to groundwater when groundwaters are depleted.
- c) *Groundwater* — Sub-surface water, or groundwater, is freshwater located in the pore space of soil and rocks. It is also water that is flowing within aquifers below the water table. Sometimes it is useful to make a distinction between sub-surface water that is closely associated with surface water and deep sub-surface water in an aquifer.

Sub-surface water can be understood in the same terms as surface water: that is, in terms of inputs, outputs and storage. The critical difference is that due to its slow rate of turnover, sub-surface water storage is generally much larger compared to inputs than it is for surface

water. This difference causes a tendency to use sub-surface water unsustainably for a long time. However, over long term the average rate of seepage above a sub-surface water source is the upper bound for average consumption of water from that source.

The natural input to sub-surface water is seepage from surface water. The natural outputs from sub-surface water are springs and seepage to the oceans. If the surface water source is also subject to substantial evaporation, a sub-surface water source may become saline. In coastal areas, use of a sub-surface water source may cause the direction of seepage to ocean to reverse which can also cause soil salinization. People can also cause sub-surface water to become unusable through pollution. The input to a sub-surface water source can be increased by building reservoirs or detention ponds (without lining).

- d) *Desalination* — Desalination is an artificial process by which saline water (generally sea water) is converted to freshwater. The most common desalination processes are distillation and reverse osmosis. Desalination is currently expensive compared to most alternative sources of water. It may be economically viable only for high-valued uses, such as household and industrial uses, in arid areas.
- e) *Rainwater harvesting* — Rainwater harvesting may be employed to augment water availability. See 7.2.1 for details.

10.2.1.2 *Project constraints and source constraints*

Quality aspects of demand depend upon functional requirements, occupancy type, pattern of use, variety of uses involved, occupant use behaviour, cold and hot water quality requirements (temperature, pressure, etc), etc.

Water quality requirements are directly related to intended use. The freshwater is intended mostly for human consumption, whereas treated waste water is intended to be used for non-potable uses. All the water supplied shall meet or exceed appropriate water quality requirements as applicable for its use. Requirements include microbiological, chemical, radiochemical, and aesthetic requirements that are applicable to quality of water for its respective uses.

The quality of available water sources is often a very important factor in water system planning and design. The quality of water for respective uses such as for domestic, flushing, irrigation, processes and construction requirements shall be in accordance with accepted standards and good practice [11(28)].

For estimation of water demand for respective types of occupancy, reference shall be made to Part 9 'Plumbing Services, Section 1 Water Supply' of the Code. Cold and hot water proportion are drawn based on the local climatic condition of the region, type of occupancy and the general use pattern in the local region.

10.2.2 Water Sourcing

Based on the functional assessment of need, availability, environmental concerns and their optimization, the water sourcing is decided. Following are alternative sources of water that are generally suitable for domestic/building water systems:

- a) Direct connection to an existing water system,
- b) Indirect connection to an existing water system (water hauling),
- c) Development of groundwater resources,
- d) Development of surface water resources,
- e) Revamping of traditional water sources, and
- f) Rainwater harvesting.

In majority of cases, in view of operation and maintenance considerations, it may be desirable to connect to an existing water supply system.

During the planning stage of project development, each potential source should be carefully evaluated in light of the water quantity and quality requirements. The final choice of source depends on many factors, such as the following:

- 1) Proximity and capacity of existing systems,
- 2) Necessary institutional arrangements for obtaining water from existing systems,
- 3) Yield and quality of available ground and surface water sources, and
- 4) Level of operation and management activity that is reasonable for the water system being designed.

The source of water is an important factor in deciding which environmental regulations apply, which shall be complied with. For the purpose, the sources may be classified as groundwater, groundwater under the influence of surface water, and surface water. Generally, surface water and groundwater under the influence of surface water, are regulated together.

Source selection should depend upon environmental considerations, reliability, cost (including capital cost and operations and maintenance cost) and water treatment facilities.

10.2.3 Hot Water Systems Planning and Design Approach

Water heating is a thermodynamic process using an energy source to heat water above its ambient/initial

temperature. Typical domestic uses of hot water are cooking, cleaning and bathing. In industry, both hot water and water heated to steam have many uses. Appliances for providing a more-or-less constant supply of hot water are variously known as water heaters, boilers, heat exchangers, calorifiers or geysers. In domestic installations, potable water heated for uses other than space heating is known as domestic hot water. The most common energy sources for heating water are fossil fuels namely coal, natural gas, liquefied petroleum gas, oil or sometimes solid fuels. These fuels may be consumed directly or by the use of electricity (which may be derived from any of the above fuels or from renewable sources). Alternative energy such as solar energy, heat pumps and hot water heat recycling may also be used as available, usually in combination with backup systems supplied by gas, oil or electricity. The equipment used should be in accordance with the concerned Indian Standards available.

Alternative hot water systems such as electric, gas fired, oil fired and solar hot water systems; and hot water system using heat recovery are evaluated based on the availability, maintainability and limitation of the fuel feed. Large centralized hot water generation on electrical power should be discouraged and alternative clean and energy efficient fuels with efficient hot water generator should be evaluated in the project having high hot water requirement. All hot water system (equipment and plumbing pipes) shall be insulated with insulation to minimise heat loss.

10.2.4 Strategies for Water Efficiency

Efficient use of water is one of the underlying principles for sustainability in water management. Selection of water efficient products should be considered for both cold and hot water systems. Use of low flow fixtures for faucets, water closets, bath showers, hand-held bidet sprays, dish washers, aerators and clothes washers should be considered. One of the important considerations to ensure performance of low flow products is to design systems with correct pressures.

Low flow fittings should be considered mainly for areas with direct water consumption/human usage such as for wash basin taps, sink taps, and shower head, bath faucet and other faucet taps. Situations where water is filled for other requirements such as bath tub fillers, washing machine and for situations where water is filled, stored, used or situation where quantity of water supply may form the intent for which water is being drawn such as fire-fighting system and swimming pools, need not be provided with water saving features/use. The strategy of water efficiency shall also include low flush and dual flush cistern/flushing mechanism.

Technologies for high efficiency toilets and waterless

urinals are emerging solutions but they need to be validated in the realistic use environment. It is important to ensure that the user's functional needs and satisfaction is not compromised. Social attitudes and user habits may need analysis while selecting such products. Dual piping is another strategy for efficient use of water. Planning and design approach to recycled water use should be integrated with dual piping systems and waste water reuse systems. In such cases, control of contamination in potable supply pipe shall be ensured.

10.2.5 Strategies for Water Conservation

Water conservation strategies aim to conserve the scarce water resource. Storm water is a major opportunity for conservation. Rainwater harvesting and rainwater recharge, and rainwater storage/use have a significant scope for conservation, especially at the neighbourhood level of developments. Rainwater can be harvested by adopting the following means:

- a) Storing rainwater for ready use, in containers above or below ground.
- b) Charging rainwater into the soil (groundwater recharging) to improve the underground water table. This needs to be critically planned as recharge is governed by stratification, groundwater table level and groundwater quality.

While water conservation strategies are most desirable in water-deficient areas, the maintenance of rainwater harvesting system assumes importance, else, they may not perform during raining days. For details reference may be made to 7.2.

10.2.6 Sustainable Design Detailing of Water Supply System Components

For a system to be sustainable, the aspects of integrated performance, reliability, maintainability, life cycle performance including under adverse conditions and capability to undergo corrections during the use phase of the buildings, shall be considered. Pre-validation of integrated system performance is desirable. It is also desirable to consider implications of procurement, contractually assigned responsibilities and technical support during installation procedures. Quality assurance and quality control systems shall be employed to guide system design and execution.

10.3 Planning and Design of Waste Water System

This involves, quantity and quality assessment study, study of domestic water use-profile and scope of recycled water use, system conceptualization and integration with other water systems; planning for collection, treatment systems (combined and independent sewage and sullage treatment plant),

treatment of on-site grey water and reuse. Sludge drying, composting and use for manure should be encouraged with proper hygiene considerations.

10.3.1 Treated Waste Water Use for Landscape and Irrigation

To reduce freshwater consumption for landscape/irrigation, it is suggested to use alternative sources of water, such as grey water, reclaimed water and collected rainwater. Grey water is untreated household waste water from bathroom sinks, showers, bathtubs, and clothes washing machines. Grey water systems pipe carry this used water to a storage tank for later outdoor watering use. Reclaimed water is waste water that has been treated to levels suitable for non-potable uses. Collected rainwater is rainwater collected in cisterns, barrels or storage tanks.

Appropriate systems to monitor the quality of treated waste water in accordance with the standard practices should be provided while designing and analyzing the building use. Required safeguards should be provided and records of treated waste water parameters should be monitored on regular basis. Quality of treated waste water should be in compliance as required for non-potable and secondary use.

Proper techniques for landscaping and irrigation in respect of selection of appropriate plant species, use of efficient irrigation systems, etc, can result in substantial water saving (*see also 7.1 and 7.3*).

10.4 Water and Waste Management During Construction

10.4.1 Water Use During Construction

Water from only authorized sources should be used for construction. Use of potable water for construction should be avoided unless required for specific purposes. It is suggested to consider use of treated waste water from appropriate sources with quality of treated waste water parameters confirming the quality required for use in construction activity. Water quality for concreting work shall be in accordance to Part 6 'Structural Design, Section 5 Concrete' of the Code. For sourcing of water, reference should be made to the statutory environmental provisions, if applicable. Inadvertent use of non-potable construction water for drinking purpose shall be prevented by proper distinct systems with appropriate markings. Wastage of construction water in piping network as well as storage tanks shall be prevented. Monitoring of water consumption shall be done by maintaining logs to control wastage and ensure its efficient use. Water efficient construction technologies should be considered along with other implications while deciding on the technology for respective construction activity.

10.4.2 Control and Use of De-Watering Output

De-watering is essential for carrying out construction works below water table. The extent of de-watering is decided on structural considerations. Assigning responsibility within the organization shall ensure control of excessive de-watering. De-watering operations generate enormous amount of water. Organizations should explore to store and use water obtained as a result of de-water either at the site of construction or at another location productively.

10.4.3 Management of Waste Water

Construction sites may have a constraint of not having a waste-water disposal, hence, the arrangements have to be made within the construction site. It is imperative that the opportunities are identified to reduce the water consumption and re-use treated waste-water. In the absence of appropriate waste-water disposal facilities, unhygienic and unsightly conditions may prevail which may cause water borne diseases and act as breeding ground for mosquitoes and develops unhealthy environment with bad odour and flies. Wastewater at construction sites may contain residues of construction materials (such as cement, sand, bentonite slurry, etc), oils and domestic waste. It should be possible to treat water, specially containing residues of construction materials and re-use the same in construction. However, disposal of other forms of wastewater should be planned in suitable manner at site after appropriate treatment.

10.4.4 Waste Management During Construction — See 12.7.

10.5 Process Water Requirement and Effluent Treatment

Certain processes, such as pharmaceuticals, hospitals, industrial processes, etc, need water quality specific to their needs. Water for such processes is to be provided in accordance with industry standards applicable to the respective industries as well as the applicable statutory environmental provisions. Therefore, planning and design of water supply schemes for such processes shall adhere to the concerned regulations and standards.

Effluent treatment of some special processes is a cause of concern. The impact of treatment of water for supply as well as process effluent shall be assessed through environmental impact assessment (EIA). Environmental management plans (EMP) should be developed to mitigate the adverse environmental impacts. In such situations, it is desirable to establish proper environmental management system (EMS) to ensure compliance to the norms through defined managerial responsibility. For such special process

facilities, proper water and effluent quality testing laboratory shall be established and records maintained to control compliance parameters.

10.6 Planning and Design of Solid Waste Management System

Solid waste generated in buildings, if not managed properly may result in unhygienic conditions, spread of foul smell, unsightly conditions and hazards such as fire within the buildings, and hindrance in productive use of building. The solid waste has also bearing on the functional planning of buildings. Collection and movement of solid waste often overlaps with building circulation and, hence can cause interference with the use that may be prohibited in occupancies such as hospitals and hotels. Thus, the interventions during planning and design are critical for solid waste management.

The cumulative effect of improper solid waste management in buildings and its indiscriminate dumping in landfill sites, is an environmental problem of immense proportions. While reduction of solid waste is aimed during building use, as a part of solid waste management it, should be considered to utilize the considerable scope of using solid waste as a resource for waste recycled products and energy. For this, solid wastes recycle facilities should be considered for building complexes. The aim should be to reduce the burden on municipal waste disposal facilities and thereby, reduce the need for transportation of wastes. Solid waste processing may include sorting out various materials and compacting for effective onward transport to re-cycling plants.

10.6.1 Documentation of Nature of Waste and Quantification

For proper planning and design of solid waste management, study of various functional areas shall be carried out. The study should include identification of solid waste that may be generated during use, their characteristics and the anticipated quantities. It may be desirable to study similar projects and take cognizance of their experiences while undertaking such identification.

It may also be desirable to study the socio-cultural context affecting behavioural aspects of users to anticipate extent of their participation in solid waste management process and appreciation of systems implemented. In planning solid waste management system from sustainability point of view, the role, responsibilities and response of users should be considered. The context of users, characteristics of waste and expected quantities shall be documented for making strategic decisions.

10.6.2 Identification of Strategies for Solid Waste Management

Considering the solid waste characteristics, expected quantity, socio-cultural context of users and possible technological solutions, strategic planning of solid waste management shall be developed. Technological and managerial alternatives shall be explored and compared. Reference shall be made to the statutory provisions governing building use and the environment. While developing strategies, the following aspects shall be considered:

- a) Solid waste minimization;
- b) Space requirement for collection sorting, movement for sorting and for disposal, including on-site pre-processing and off-site transport in accordance with legal provisions;
- c) Effectiveness of possible alternatives;
- d) Environmental sensitivity for solid waste processing and constraints of off-site disposal;
- e) Organizational constraints of building occupants to participate and involve in management of solid waste; and
- f) Economic considerations of technology and their reliability.

The strategic approach to solid waste management shall be documented as a report that shall form a basis of planning and engineering services design.

10.6.3 Solid Waste System Planning

Documented strategic approach should lead to planning of the system as the preliminary design begins to evolve. Design configuration shall consider solid waste management also as one of the functions of the building. Planning and design shall include appropriate physical space requirements for,

- a) provision for collection at suitable locations for solid waste to facilitate the occupancy functions;
- b) need for ventilation, washing, isolation and provision for persons performing duties of waste collection;
- c) provision of appropriate containers for wastes;
- d) circulation planning for solid waste from individual collection locations to central facility (for example, waste chutes, physical movement through service corridors, etc);
- e) segregation space with necessary illumination, ventilation, washing and other provisions for performing segregation duties at appropriate location(s);
- f) treatment facility within the building or building complex for compacting for recycling

and disposal (for transport to city level facility), composting for biodegradable waste, re-cycled materials, and heat recovery during disposal through thermal chambers; and

- g) composting and manure generation systems in buildings, clusters, neighbourhoods, districts and city levels.

Composting and manure generation at all levels opens up channels to capture substantial part of biodegradable waste and increases green activity like gardening and vegetable growing. The system can reduce, recycle, reuse and regenerate as per sustainability concept. Adequate protection shall be provided to segregate waste area to permit restricted access to only authorised personal. Access to birds and animal should be strictly avoided. The solid waste disposal system should try to use the combustible but non-recyclable items like dry plant parts, wooden wastes, fabric waste, etc, for waste-to-energy systems at district level on wards. Using combustible garbage items for energy generation will reduce volume of garbage to be disposed, transportation along with requirement of land fill sites. Energy generation will reduce the carbon foot print of the area/zone and hence the sustainability of the building.

A schematic plan for solid waste management shall be developed and coordinated with the building plan. Schematic plan shall also indicate technologies employed in the process of solid waste management after due consideration to alternatives, cost implications to the project; statutory approvals that may be needed; specifications of civil and engineering works needed to be executed, contractual conditions for executing agencies; etc. Documented plan shall be the basis for preparing detailed designs.

10.6.4 Design Detailing of Solid Waste System Elements

Design of solid waste system shall coincide with detailed architectural and engineering design. While physical space requirements are necessary for the architectural design, design calculations for engineering services requires inputs from various elements of waste management. Design detailing should be adequate to ensure information needed for vendor selection and tender action.

System design detailing shall ensure that the components are compatible with each other. For instance, the design of segregation facility shall consider aggregate space requirement arising out of various collection locations. Similarly, the quality of finishes should be compatible with the nature of waste and the processes needed.

From sustainability considerations, it is desirable that the representative group and other stakeholders review

the proposed solid waste management system, including technical and managerial component, so that the performance is assessed from multiple standpoints. See also Part 9 'Plumbing Services, Section 3 Solid Waste Management' of the Code.

10.6.5 Provisions for Waste(s) Requiring Special Management

Wastes generated in special occupancies and processes need safe handling and disposal in accordance with industry practices, and statutory and environmental laws. Buildings are required to make special provisions, physical spaces and measures to collect, segregate, transfer and dispose of the waste. Management system should be established for disposal of such special wastes. Management systems should define delegation of responsibilities, prerequisite competencies, procedures, protection for personnel performing waste management duties and procedures for emergencies and disaster management. Issues related to wastes requiring special management shall be taken care of as follows:

- a) *Biomedical hospital waste management* — Hospital wastes include human parts, infectious materials, shrapnel (needles, surgical blades, etc) and radioactive materials. Each of the waste types shall be collected and segregated at designated locations as per the norms applicable, with adequate precautions for safety, disinfection and containment. The circulation route for waste shall be segregated from other hospital circulations. Location for further processing of waste for final disposal shall be defined at the master planning stage. Special care shall be taken for ventilation exhaust so that the same does not mix with air intakes in hospital ventilation system. The hospital waste shall be treated using appropriate technologies like incineration, autoclaving, microwave or hydroclave and also as per the statutory laws and procedures.
- b) *Management of radioactive waste* — Disposal of radioactive waste shall be carried out strictly in accordance with the Board of Radiation and Isotope Technology (BRIT)/ Atomic Energy Regulatory Board (AERB) regulations/guidelines. In such cases, proper records shall be maintained as required by the regulatory authority concerned.
- c) *Management of toxic and chemical waste* — Toxic chemical wastes shall be disposed of according to the relevant regulations, standards and best industry practices. Under no circumstances, these should be disposed into sewerage. Specific arrangements shall be provided for management of emergencies such

as control of spread of toxic fumes and emergency health care to the exposed populations.

- d) *Management of inflammable and combustible wastes* — Combustible and inflammable waste is a potential source for fire hazards in buildings. Collection, segregation and handling of such wastes shall not be carried out in vicinity of any source of ignition. Adequate provisions for spread of smoke and fire-resisting enclosures shall be provided at locations for collection and segregation. Necessary fire protection measures, such as portable extinguishers, fire hydrants and sprinklers should be provided considering fire risk, damage potential and statutory provisions. Provisions under explosives act shall be followed for storage and disposal, as applicable.
- e) *Management of electronic waste* — These shall be taken care of in accordance with the applicable act, rules and regulations relating to the management and handling of e-waste.

10.7 Integrated Approach to Water Supply, Water Waste and Solid Waste Management

An integrated approach towards water supply, waste water and solid waste management should be adopted with a view to meeting the objectives as given in 10.1 to 10.6 in respect of these.

10.8 The construction and demolition waste management shall be done in accordance with 12.7.

11 BUILDING SERVICES OPTIMIZATION

11.1 General

Optimization of electro-mechanical services is one of the important aspects towards achieving a sustainable building. Reduction in heating, cooling and lighting loads through climate-responsive designs and conservation practices can enhance the energy efficiency of a building. In addition, an integrated project delivery (IPD) approach results in a well-designed, cost effective solution wherein all building systems and components can in coherence facilitate overall functionality as well as required environmental performance. The passive design features and proper initial planning helps in reduced energy demand and, therefore, the same should be carefully analysed prior to actual sizing of equipment where provided.

11.2 Concept Development

In addition to achieving the optimum energy performance, the building should also provide the desirable thermal and visual comfort to its occupants.

Incorporating solar passive techniques in a building optimizes building performance by minimizing the use of artificial energy and thereby minimizing load on conventional systems for heating, cooling, ventilation, lighting, etc.

Solar passive techniques that can be adopted in different climate zones of India are,

- a) landscaping (to reduce heat island effect);
- b) optimum building orientation;
- c) arrangement and shape of buildings;
- d) effective surface to volume ratio;
- e) location and size of openings on building facade and other elevation;
- f) glazing type and performance; and
- g) shading devices on windows and judicious selection of building materials.

Prior to developing the design drawings, the design team shall carry out a thorough review of the fundamental assumptions, owner's brief and available resources on site, in an integrated manner, addressing the key target issues such as the following:

- 1) *Building orientation* — Building orientation affects many aspects ranging from energy performance to visual simulation of the building. Building location and its exposure to solar direct radiation affect the HVAC design, day-lighting strategies and the overall energy demand.
- 2) *Building envelope* — Building envelope provides a starting point for determining heat transfer coefficients for external walls/ceiling/roof and glazing (see 8 for details).
- 3) *Harvest site energy* — Project shall explore the use of natural resources such as daylight, variations in ambient temperature (economizer cycles) to reduce cooling/heating demand and utilize solar/wind energy. For large projects, the master planning team should explore district level solutions and identify potential site integrated opportunities.
- 4) *Design assumptions and internal load assessment* — Energy demand reduction may be accomplished by carefully analyzing the initial design assumptions and by reducing internal heating and/or cooling loads and interior lighting improvement. It can be achieved through multiple design strategies such as reducing the overall building footprint, reviewing the indoor temperature design criteria to allow for a wider acceptable band, on-demand operation of utilities (using sensors to link the operation to an established criterion), climate responsive envelope, etc. In case of air-

conditioned building, the project team may also consider a review of indoor design temperature (which is consistent with adaptive thermal comfort model) as every degree shift closer to outdoor design temperature can help in optimizing the equipment sizing. In addition, the thermostat set point temperature can be kept closer to seasonal average outdoor temperature during regular operation to minimise building energy consumption.

- 5) *Maximize efficiency* — Energy consumptions should be optimized to avoid over-sizing of equipment rating. It may be achieved by analyzing the estimated monthly and annual energy consumption profiles of the building and compare the same with building peak loads. Computer based design tools may be used to identify feasible energy conservation measures for a building.

11.3 Natural and Mechanical Ventilation Strategies

The term natural ventilation is used to describe air movement caused by naturally produced pressure differences due to wind and the stack effect. Natural ventilation is achieved by infiltration and/or by allowing air to flow in and out of a building through doors, windows, openings, louvers and *Jalis*. Typically, preferred mode of ventilation in non-air conditioned spaces is by natural draft or convection. A thorough assessment of natural *versus* mechanical ventilation strategy should be performed to minimise the need for artificial cooling by lowering the space temperatures (of attics) as well as eliminate/minimise the need for mechanical blowers. For this, validation through computer simulation may be helpful. Following are some of the important aspects which may be considered for the purpose:

- a) *Stack effect* — Convective air currents may be induced in a building by exploiting temperature difference between a space and the environment adjacent to it as the lighter warm air rises to be replaced by cooler air. This phenomenon may be especially useful for ventilation in tall buildings, vertical passages such as stairwells, elevators, and shafts. This helps in reducing the fan power energy demand.
- b) *Wind-induced pressure differences* — Wind pressure on a building depends on wind direction, speed, shape of the building and location of its openings. The spatial cooling techniques may be explored through windows/openings to induce airflow from the windward side and outflow on the leeward side. This is especially suited for tall buildings.

- c) *Night purging* — Night purging takes advantage of the diurnal variation in temperatures to lower the cooling demand of the space. In regions, where a significant difference exists between day and night temperatures, this technique is useful for dissipating heat by flushing the indoor space through ambient cool air.
- d) *Wind towers* — Use of wind towers may be explored in hot and dry climates for cooling. The function of this tower is to catch cooler breeze that prevail at a higher level above the ground and direct it into the interior of the buildings. Wind towers operate in many ways depending on the time of day and wind availability.

11.4 Passive Heating Techniques

Passive heating is the spontaneous warming effect resulting from the absorption of solar radiation wherein solar energy is exploited to induce heat flow from the affected surface to indoor air, as well as promote heat storage within the building structure. In the climatic zones requiring indoor space heating, it may be explored to use the following strategies:

- a) *Direct gain method* — Controlled sun may be permitted into the habitable spaces through an opening to directly heat the floor, walls or other internal components and objects, which, in turn, heat the air within the room. Some examples of building materials that enable direct solar gain by acting as thermal storage mass are concrete, bricks, stone and water. The high thermal mass is usually located in the internal or external walls, floors or other built-in structures that receive sun directly.
- b) *Indirect gain* — A thermal storage wall may be placed between the glazing and habitable space which prevents solar radiation from directly entering the living space. The solar energy incident on wall is absorbed by the wall and then indirectly transmitted to the habitable space over a longer time.
- c) *Trombe wall* — It is a thick solid wall with vents at its lower and upper ends. This wall may be placed directly behind the glazing with an air gap in between. The vents act as inlets of warm air into the room and as outlets for flushing out cool air from the room.
- d) *Solar chimneys* — This system is a kind of modified trombe wall that is incorporated into the roof. A solar chimney is essentially a collector panel with minimum thermal inertia on the south facade of the building. It absorbs incident solar radiation and heats up the air inside the space.
- e) *Sunspaces/Solaria* — It is an integration of direct gain and thermal storage concepts. Solar radiation admitted into the sunspace heats up the air, which by convection and conduction through the mass wall reaches the habitable space. It essentially consists of a greenhouse constructed on the south side of the building with a thick mass wall linking the two.

11.5 Passive Cooling Techniques

Passive cooling systems rely on natural heat sinks to remove excess heat energy from a building. They derive cooling directly from evaporation, convection and radiation without using electrical energy. All strategies rely on diurnal changes in temperature and relative humidity. The applicability of each system depends upon the prevailing climatic conditions.

The building envelope can be designed to effectively exchange heat with the surrounding ambient air. In order to have an appreciable net heat flux between two bodies, the temperature difference should be significant (typically at least 7°C). Some of the techniques are as follows:

- a) *Nocturnal cooling* — In this technique, night sky cooling may be very effectively used to dissipate the heat stored in building envelope so that it is regenerated to store the day heat gain. Such buildings will require high thermal mass and application is ideally suited for day use buildings such as offices.
- b) *Roofpond with movable insulation* — A water body on the roof may provide cooling where during summers it is covered with insulation with a surface finish of low absorptivity. During the day time, this minimises the solar radiation impact on the roof, as the water in the pond holds the heat gain and further increases the time lag. During the night, insulation is removed and the heat stored in the day time is exchanged with the night sky. In winter, the operation of the movable insulation is reversed to allow heat gain in daytime and reduce heat loss during the night. All such provisions shall however be without prejudice to the need of compliance to the requirement of structure safety as prescribed in this Code.
- c) *Courtyards* — Due to incident solar radiation in courtyards, the air gets warmer and rises. Cool air from ground level flows through louvered openings of rooms thereby inducing airflow.

11.6 Pre-Cooling of Ventilation Air

To conform to the IAQ requirements, it is necessary to introduce outside air for ventilation of conditioned spaces. This enables reduction in internal air-contaminants, as well as dilutes odour from occupants. The introduction of hot and humid air leads to significant increase in cooling/heating load and, therefore, strategies, as follows, may be considered to minimise the energy demand:

- a) *Demand controlled ventilation* — Carbon dioxide or air quality sensors may be used to check the level of pollutants in the occupied space and provide the indication to building management system to control the opening of outside air dampers thereby effectively providing ventilation on demand.
- b) *Heat recovery* — Pre-cooling of hot/cold outdoor air can be achieved by recovering energy from exhaust streams of a building (toilet/pantry/atrium) through either heat recovery wheel, run around coils, cross plate heat exchangers or heat pipes. This helps in lowering the installed capacity of cooling/heating equipment.
- c) *Economizer cycles* — In certain climates, air and/or water side economizer cycles may be used to take advantage of lower ambient air temperatures. Outside air load may be reduced by pre-treating the air and possibly combining strategies like earth air tunnel and adiabatic cooling.

11.7 Low Energy Mechanical Cooling Techniques

It is desirable to explore possibility of using low energy cooling/heating techniques for indoor space as an alternate for compressor driven energy intensive conventional air-conditioning systems. Passive systems in combination with mechanical systems may also be suitably hybridized to offer systems that have significant lower energy consumption in comparison to conventional HVAC systems. The following alternative technologies may be considered for implementations to comply with the comfort criterion:

- a) *Evaporative cooling* — It is suited for hot climates with low humidity. The cooling of air is achieved by simple evaporation of water in air. In high humid climates, evaporative cooling may have little thermal comfort benefit beyond the increased ventilation and air movement it provides. Various types of evaporative coolers are as follows:
 - 1) *Direct (single stage) evaporative cooling (open circuit)* — It lowers the temperature of air by using latent heat of evaporation

thereby changing water to vapour state.

- 2) *Indirect evaporative cooling (closed circuit)* — It is similar to direct evaporative cooling, but uses a heat exchanger. In addition, in indirect evaporative cooling, the cooled moist air does not come in direct contact with the conditioned environment. Efficiency of these systems is low as compared to direct evaporative cooler.
- 3) *Two-stage evaporative cooling or indirect-direct system* — It does not produce humidity levels as high as that by traditional single-stage evaporative coolers, but operate at a lower efficiency. Two stage evaporative coolers combine indirect with direct evaporative cooling.
- 4) *Passive (or natural) downdraft evaporative cooling (PDEC) system* — It is a low energy passive system. PDEC system does not need the blower and require only pump for re-circulating water. Some designs may even eliminate the re-circulation pump and utilize the pressure in the supply water line to periodically surge water over the pads thereby eliminating the requirement for any electrical energy input.
- b) *Desiccant dehumidification/cooling systems* — Desiccant dehumidification/cooling technology provides a tool for controlling humidity levels for conditioned air spaces.
- c) *Geothermal heating and cooling* — Geothermal exchange loop use the constant temperature of the earth as the exchange medium instead of the outside air temperature. As the ground is warmer than ambient air during winters and cooler than ambient air during summers, geothermal exchange loop harnesses this phenomenon by exchanging heat with the earth through a ground to water/air heat exchanger. Thus it helps in meeting indoor heating/cooling demand and also hot water generation for small scale buildings like homes and commercial establishments. Geothermal exchange loop can be classified as closed looped system and open loop system. The pipes can be installed in three ways, namely, vertically, horizontally and in a pond or lake, depending upon the availability of land area and soil type at the chosen site.
- d) *Earth air tunnel system* — As earth temperature remains constant throughout the year at a depth of 4 m to 5 m, an earth air tunnel (EAT) is created by burying a pipe at this depth. Ambient

air, thus sucked from one end is passed through EAT and depending on the ambient temperature, air gets cooled in summer and heated up in winter. This cooled/heated air is then supplied to the various areas in the building for meeting space cooling/heating demand and can provide recommended thermal comfort to the building occupants.

- e) *Radiant cooling or thermally active building systems* — These systems work on the principle of thermal storage of energy (heating/cooling) within the building structure components such as slabs, false ceiling, walls, etc. Further the building components radiate the heat/coolness to the building interiors thereby off-setting the heating or cooling loads. These systems specially work best in climates with high diurnal variations. These systems can be integrated with the HVAC system or can operate independently.

11.8 HVAC System

The following may be considered with regard to planning, design and installation of HVAC system:

- a) *Equipment sizing* — As the air conditioning system account for nearly 50-60 percent of annual electricity bill for a conditioned building, prior to equipment selection, it is important to optimally size the cooling and heating equipment of the building. As the internal loads may not peak simultaneously at any given time, a suitable diversity factor may be considered for sizing the equipment. Multiple smaller machines, chiller with multiple compressor or variable frequency drive (VFD) on chiller may be explored for ensuring operation at highest efficiency point in spite of variation in demand.
- b) *Unitary/split equipment* — The unitary products like window air conditioners and split units are ideally suited for standalone smaller applications like houses and shops. However, the IAQ and energy efficiency need a special attention. These shall conform to relevant Indian Standards.
- c) *Variable refrigerant flow systems* — These are the systems for middle size commercial establishments like shops, small hotels, nursing homes, restaurants, large residences, bank, education institutes, small office, etc and can provide a superior performance over conventional unitary equipment/package units. However, the IAQ, redundancy and long refrigerant pipe lengths required, need a special attention.

- d) *Central plants* — These are ideally suited for all medium and large scale projects that require air-conditioning wherein the chilled water is transported to remote air terminal units for heat transfer. The water chilling machines (chillers) are categorized with respect to type of compressor and heat transfer mechanism. Their selection calls for a careful review in terms of anticipated variation in load, part load efficiency, redundancy, etc. The benefits of central plants include highest efficiency, reduced maintenance costs and overall lower total installed capacity (due to overall diversity) in comparison to other options.

- e) *Water chilling machines (chillers)* — Chillers may be used either singularly or in groups and in either air-cooled or water-cooled options. As a guideline, air-cooled chillers are recommended when water is either in scarce supply and/or expensive or in case the ambient conditions are favourable. Water-cooled chillers are more energy efficient than the air-cooled chillers but do require a cooling tower which demands a supply of suitably treated water. Cooling tower may be provided with side stream filtration system to conserve water that is wasted away during blow down. They have a longer operational life and are often selected for larger capacity applications. It is worthwhile to look at other saving strategies like heat recovery (heat machine/heat pumps/de-superheater/double bundle condensers/condenser heat recovery/heat recover in AHUs), possibility of hybrid cooling options or closed cell cooling towers to reduce energy consumption. The use of recycled water from a sewage/effluent treatment plant for cooling tower make-up is desirable.

There are two recognized methodologies to determine chiller efficiency namely coefficient of performance (COP) and integrated part load value (IPLV). This offers a mathematical way to rate and compare single chillers but is not suitable for multi-chiller configurations. With energy modelling, multi-chiller configurations may be simulated with greater accuracy. Early use of recognized modelling software in the design process may help in addressing common design shortcomings such as, the tendency to over-size chiller installations.

Parameters that need to be optimized while designing a chiller-water plant include flow rates and temperatures, pumping options, plant configuration and control methods. For each specific consideration, the design professional

should understand the owner’s need, objectives and implement the chiller plant options to best satisfy them.

It is also worthwhile to look at other energy saving strategies like heat recovery (heat machine/de-superheater), low flow applications (higher ΔT) on chiller and condenser, low approach cooling towers, series counter flow configuration, use of variable frequency drives, advanced controls, water economizers, lower fouling factors, higher chilled water temperature, etc, for reducing the energy demand. In addition, use of VFD in compressor may also be explored in case it offers improved part load efficiency.

- f) *Refrigerants* — Refrigerants are classified into two classes based on their toxicity, namely Class A having lower chronic toxicity and Class B having higher chronic toxicity. They are classified into four classes based on their flammability, namely, Class 1 (no flame propagation), Class 2L (lower flammability), Class 2 (flammable) and Class 3 (higher flammability).

Refrigerants shall be designated and classified for safety in accordance with the accepted standard [11(33)].

1) *Matrix Diagram of Safety Group Classification System*

The toxicity and flammability classifications for refrigerants as above yield eight safety groups, namely, A1, A2L, A2, A3, B1, B2L, B2 and B3. These safety groups are represented by the matrix shown below:

Safety Groups as Determined by Flammability and Toxicity

Toxicity → Flammability ↓	Safety Group	
	Lower Toxicity	Higher Toxicity
Higher flammability	A3	B3
Flammable	A2	B2
Lower flammability	A2L	B2L
No flame propagation	A1	B1

- 2) While selecting refrigerants, manufacturers and designers shall adopt balanced approach considering environmental impact and human health. The key

criteria that shall be considered are as follows:

- i) *Ozone depletion potential (ODP)*— ODP of the refrigerant should preferably be zero and shall be as permitted under *The Ozone Depleting Substances (Regulation and Control) Amendment Rules, 2014* as amended from time to time (*see Note*);
- ii) *Global warming potential (GWP)*— GWP of the refrigerant should preferably be low to reduce greenhouse gas (GHG) emissions, which is in line with the ongoing discussion for phase-down of production and consumption of hydrofluorocarbons (HFCs);
- iii) Refrigerant with zero ODP and low GWP should be adopted for balance approach considering overall environmental impact;
- iv) *Flammability* — The refrigerant should preferably be non-flammable/ having flammability as low as possible, and suitable risk mitigation process/infrastructure (sensors, ventilation, etc) should be opted to mitigate the risk of flammability, if any in line with the accepted standards;
- v) *Toxicity* — The refrigerant should have toxicity as low as possible, and suitable risk mitigation strategies/ infrastructure (sensors, ventilation, etc) should be opted to handle toxicity, if any in line with the accepted standards; and
- vi) The refrigerant should also support other key performance parameters, including high energy efficiency, low emissions, chemical and thermal stability and material compatibility.

NOTE — The production and consumption of ozone depleting substances (ODS) including HCFCs, for example, HCFC-22 and HCFC-123 is being phased out by 2030. The import of refrigeration and air conditioning equipment containing HCFCs has already banned from 10 July 2015, and the manufacturing of all such equipment with HCFC will be banned in the country from 01 January 2025 in accordance with *The Ozone Depleting Substances (Regulation and Control) Amendment Rules, 2014*.

For ODP, GWP and safety group (flammability and toxicity) of different refrigerants, reference shall be made to Table 8. As there are ongoing developments with respect to refrigerants with HCFC Phase-out Management Plan (HPMP) and HFC phase down proposals, latest regulations applicable at the time of selection of equipment/systems with various possible refrigerants shall be followed. As research is going on for alternative refrigerants to various HCFC/HFC/HFO refrigerants, it is recommended that project teams should make a conscious effort to select equipment/systems with refrigerant with high energy efficiency, least negative impacts on health, safety and environment as per the latest developments.

- g) *Chilled water pumping systems* — In a central plant, the pumping systems contribute to second largest energy consumption source and it should be carefully analysed for selection for highest efficiency point and required head only. It is recommended to install variable frequency drives for all applications. There

are following two types of chilled water pumping system options:

- 1) *Primary-secondary (decoupled) system* — In this system, flow rate through each chiller remains constant and yet accommodates a reduction in pumping energy, since the system water flow rate varies with the load.
- 2) *Primary only variable flow (PVF) system* — In this system, flow varies through evaporator. It helps in saving on initial as well as operating costs/energy. The control strategy/priorities of a PVF system are significantly different from that of a primary-secondary system.
- h) *Thermal energy storage (TES)* — TES is a technique ideally suited for utilizing advantage of differential power tariff and power rationing during peak load hours. This becomes a tool for use by the designer as conventionally peak load may be considered as refrigeration load for selecting equipment capacity; thus, in such case most part of day refrigeration machine operates at part loads or kept idle. To

Table 8 ODP and GWP Values (100 Year Values) and Safety Group of Different Refrigerant Types

[Clause 11.8 (f)]

Sl No.	Refrigerant		ODP	GWP	Safety Group {see Accepted Standard [11(33)]}
	Refrigerant Number	Composition Designating Prefix			
(1)	(2)	(3)	(4)	(5)	(6)
i) Hydrochlorofluorocarbons (HCFC):					
a)	R-22	HCFC	0.055	1 810	A1
b)	R-123	HCFC	0.02	77	B1
ii) Hydrofluorocarbons (HFC) and their Blends:					
a)	R-32	HFC	0	677	A2L
b)	R-134a	HFC	0	1 300	A1
c)	R-245fa	HFC	0	858	B1
d)	R-404A	HFC	0	3 922	A1
e)	R-407C	HFC	0	1 774	A1
f)	R-407F	HFC	0	1 825	A1
g)	R-410A	HFC	0	2 088	A1
h)	R-507A	HFC	0	3 985	A1
j)	R-448A	HFC	0	1 386	A1
iii) Hydrofluoroolefins (HFO):					
a)	R-1233zd(E)	HFO	~0	1	A1
b)	R-1234ze(E)	HFO	0	0.97	A2L
c)	R-1234yf	HFO	0	0.31	A2L
d)	R-1336mzz(Z)	HFO	0	2.0	A1
e)	R-514A	HFO	0	1.75	B1
iv) Hydrofluoroolefins (HFO)/Hydrofluorocarbons (HFC) Blends:					
a)	R-452A	HFO and HFC blend	0	2 141	A1
b)	R-452B	HFO and HFC blend	0	675	A2L
c)	R-513A	HFO and HFC blend	0	573	A1
v) Natural Refrigerants:					
a)	R-718 (Water)	—	0	0	A1
b)	R-744 (Carbon dioxide)	—	0	1	A1
c)	R-717 (Ammonia)	—	0	0	B2L
d)	R-290 (Propane)	HC	0	3.3	A3

overcome this shortcoming, concept of thermal energy storage may be evaluated to store the energy during the time when load is less than installed capacity and releases the energy when the load is more.

Thermal storage systems may be suitable for situations wherein, due to water shortage the usage of water cooled chillers are limited. The air-cooled chillers may run during nights when the ambient temperatures are lower. Also, the technique may help reduce the size of the refrigeration equipment, installed electrical sub-station equipment and power back up requirement. Recommended to evaluate the option of placing ice/chilled water storage tanks in parallel/series arrangement.

- j) *Vapour absorption system* — Alternate sources of energy particularly waste steam/heat may be used for refrigeration. One such system uses water as the refrigerant and lithium bromide as the absorber. It has less moving parts and hence results in lower power consumption. Vapour absorption system may also utilize waste heat from the diesel/gas generating sets/bio-waste using heat recovery boilers or heated water from the solar panels to produce cooling in buildings.

Vapour absorption machines may also be considered in co-generation systems.

- k) *Air handling units (AHU)* — Choice of air handling units with supply and return/exhaust air fans may help in energy saving. During free cooling conditions when the ambient temperature is comfortable, the supply fan draws all outside air, whereas the return/exhaust fan exhausts the air from the conditioned area. The air handling unit with VFD may be considered so as to meet the varied air quantities for various seasons. This can work in tandem with a variable frequency drive.

The air handling units work in sequence with heat recovery wheel with which the fresh air drawn may be cooled by return air resulting in energy saving while maintaining the IAQ levels which requires higher outside air. Toilet exhaust fans may be connected with an infrared sensor/timer or such other means which facilitates operation only during occupancy.

- m) *Server rooms/data centre* — Facilities such as server rooms and data centre that require round the clock operation and high energy demand are beyond the purview of this Part. However, as smaller server and hub rooms are

part of every building that has multiple computers, for such installations use of dual fluid precision units may be considered. When the chiller is in operation the unit is running in chilled water mode and shifts to direct expansion (DX) mode when the chiller is not functional. When the chilled water temperature is maintained higher, it can run on both chilled water and refrigerant mode so as to meet the duty conditions. The blowers may be of variable volume type or with electronically commutated (EC) motors to meet varying duty conditions. Where DX system is used, its unit should have variable speed compressor to best efficiency.

- n) *Fans and blowers* — Proper selection of a fan for a given application requires consideration of the following factors:

- 1) Required air flow (volume);
- 2) System pressure drop at required flow;
- 3) Operating point;
- 4) Type of installation namely, ducted or free flow;
- 5) Air flow configuration, for example direction of inlet and outlet flow;
- 6) Nature of air to be handled namely, clean, contaminated or hot; and
- 7) Space constraints.

It is recommended to select high efficiency fans and couple them with equally efficient motors (preferably high efficiency IE2/IE3 type as per accepted standard [11(34)]). Use of EC motors can also be a viable option for lower rating fans. Other factors such as type of belts (V or flat), airflow (axial/centrifugal/mixed mode), fan types (backward/forward/plug) and use of guide vanes, may be considered appropriately.

- p) *Air distribution* — The design of an air distribution system should take into consideration the factors of occupant variables and space conditions so that occupants' heat loss is maintained at a comfortable rate. Occupant variables include activity level, metabolic rate and clothing levels. Space conditions are influenced by dry bulb and radiant temperatures, relative humidity and air velocity. Various types of air distribution methodologies that may be adopted on a project are:

- 1) *Mixing air systems* — To improve the efficiency of such mixing air systems, a careful analysis of the energy savings accrued due to improved COP such as the

increase in fan power should be carried out for effective implementation. Most mixing air systems tend to be designed using a constant volume flow in the occupied zone. A good strategy for optimizing energy usage should be to examine the feasibility of incorporating a pressure independent, variable air volume system. Such systems can constantly monitor the air flow needs in any occupied zone and continuously modulate the air flow to the occupied zone.

- 2) *Variable air volume systems* — Cabins and conference areas which have partial usage may be provided with variable air volume units so that they may be operated based on the usage which further results in energy saving. Variable air volume units coupled with motion sensors enables closure of the units to the minimum levels to enhance energy efficiency.

Open areas may also be provided with variable air volume units for various zones so that the zones may be operated based on the usage. They may be actuated by a motion sensor so that the VAV will close to the minimum position in the unoccupied areas. Variable air volume unit further facilitates change of temperature set points during various seasons. Zones located in the building periphery which have the direct solar exposure should be equipped with variable air volume units.

- 3) *Displacement Systems* — In the case of displacement systems, while evaluating the primary air flow, complete mixing is not assumed. Only direct heat infiltration into the occupied space from the entire fabric load is considered for the room sensible heat evaluation. All fabric loads from walls and glazing above the occupied zone, the loads from the ceiling, lighting, etc, should be accounted for, for determining the return air heat gain. This results in significantly lower primary air requirement, leading to smaller fan and fan motor sizes. In addition, due to the higher primary air temperature, the COP of the refrigeration system may be significantly improved.

The ventilation efficiency of the displacement system is generally about twenty percent higher as compared to a mixing air system. This permits the use

of lesser volumes of outside air for ventilation. As the primary air is admitted directly into the occupied zone, it shall be done at very low air speeds to avoid uncomfortable drafts. This results in low outlet velocity, low noise levels and pressure drops leading to quieter operation, improved thermal comfort, increased energy savings and improved IAQ.

- 4) *Under floor air distribution systems* — A well designed system requires less energy and is more flexible in providing and maintaining building services than traditional overhead systems. Low operational static pressures in the under floor air supply plenum may help to reduce central fan energy use. In such system, the thermal exchange with surroundings is reduced leading to better efficiency. For improved thermal comfort and maximized energy savings, it is also possible to provide under floor VAV terminal units. A ducted system facilitates the use of under floor VAV Units, particularly in perimeter zones or in special zones that are subject to load variations. It is desirable to insulate the under-floor to prevent thermal gain, especially if the floor below is at elevated temperatures, and also to prevent condensation on the ceiling slab below.
- 5) *Chilled beam and slabs systems* — Chilled beams and slabs are increasingly finding acceptance for energy efficient, comfortable, quiet operation in a robust system with very few moving parts and low maintenance needs. The system benefits from the increased density and energy carrying capacity of water, hence are more energy efficient than forced air systems.
- q) *Ducting* — The ductwork should be appropriately sized and balancing dampers need to be installed to reduce velocity losses. Ducts with larger cross sectional areas have much lower resistance and can reduce fan energy significantly. Duct having cross-sectional shapes such as round or oval can further reduce losses. Lower air speeds in duct reduce energy needs and noise. Ducts should be insulated and sealed but indoor air quality issues should also be considered. Factory made ducts with good workmanship may result in the lower leakage losses.

- r) *Variable speed drives* — Variable frequency drives (VFDs) are used for energy saving. These drives may be used on condenser water circulation pump (to modify the flow rate), cooling tower fans (to modulate the speed of fan during low ambient). Chillers, primary and secondary water circulation pumps set by sensing the temperature and pressure differential in the chilled water lines. Two way motorized valves in the air handling units may be actuated by a thermostat which varies the flow according to the loads resulting in pressure changes which may be sensed and used for changing the speed of the pump sets.

These drives should be used on,

- 1) condenser water circulation pump to change the flow during low load or low condenser water to optimize the plant room efficiency;
- 2) cooling tower fan to change the speed of fan during low ambient to optimize the plant room efficiency;
- 3) water cooled chillers with VFD unload more energy efficiently on part load, and;
- and
- 4) primary and secondary chilled water circulation pumps.

Variable speed drives are used for the air-handling units. Variable air volume units regulate the airflow for various zones based on the occupancy and temperature by a variable air volume unit, which gives a pressure signal for the VFD to change the speed of the air handling unit.

A demand controlled ventilation system uses a variable speed drive operating based on the opening and closure of the fresh air dampers controlled by the carbon dioxide sensors. A typical basement exhaust system may use a variable speed drive controlled by carbon monoxide sensors centrifugal/screw chillers with variable speed drives.

Projects in composite climate with 24 h working schedules may incorporate free cooling systems.

- s) *Controls* — Usage of accurate/sensitive controls may save power by 10 to 20 percent. Building control system plays an important part in the operation of a building and determines whether many of the sustainable design aspects included in the original plan actually function as intended. The main objective is to improve the quality and supply of information on the air conditioning system and to thereby reduce the operating costs. The

system can establish basis which may be used as bench mark for energy efficient operation subsequently. Use of intelligent control at HVAC plant room level may be considered for efficient communication and operation of all HVAC plant room components.

11.9 Electrical System

Efforts should be made to select electrical installations and systems which are energy efficient, while complying with the Indian Standards for the same which provide apart from efficiency, the various other important requirements including relating to performance and safety.

The requirements for energy efficient design of electrical installations in buildings are classified under the following four categories:

- a) Minimizing losses in the power distribution system,
- b) Reduction of losses and energy wastage in the utilization of electrical power,
- c) Reduction of losses due to the associated power quality problems,
- d) Appropriate metering and energy monitoring facilities, and
- e) Reduction in losses due to usage of inefficient/old motor, replacing motors with IE2/IE3 motors as per accepted standard [11(34)].

The active energy efficiency measures include making use of energy saving equipment, low energy lighting, efficient motors, low loss transformers, efficient appliances, suitable power carrying devices and optimized electrical distribution. These active measures along with high efficiency standby emergency generating plants using diesel, natural gas, alternate fuel, etc coupled with high efficiency uninterruptible power supply (UPS) systems contribute towards sustainable development.

Passive features include good practices like simple switching off (to turn off a device when not in use), paying attention to vampire electric loads (associated with electronic appliances like computers), etc.

Some of the recommended design criteria that may be adopted are as follows:

- 1) The transformer selection may be done in accordance with minimum efficiency performance standard (MEPS).
- 2) Higher voltage distribution systems should be employed for high-rise buildings to suit the load centres at various locations.
- 3) The locations of distribution transformers and main LV switch boards should preferably be sited at their load centres.

- 4) To reduce energy losses in the conductors of cable and bus-bar trunking, their appropriate selection should be done based on voltage drop calculations.
- 5) Reduction of energy losses in the conductors of cables and bus-bar trunking may be kept in mind in the choice of conductor cross-section.
- 6) Use of bus ducts/rising mains (stacked configuration) in place of multiple runs of cables and use of dual-bus design with bus coupler is recommended for better fault current withstanding capacity, avoidance of fire hazard, and ensuring higher reliability with low energy loss in the main power distribution system.
- 7) The loss of every main circuit connecting the distribution transformer and the main incoming circuit breaker of a LV switchboard should be minimised.
- 8) The effective current-carrying capacity of neutral conductors should have ratings not less than those for the corresponding phase conductors.
- 9) The maximum loss in every feeder circuit/sub-main circuit should not exceed 1.5 percent of the total active power transmitted along the circuit conductors at rated circuit current.
- 10) The maximum loss for every single-phase or three-phase final circuit/sub-main circuit over 32A should not exceed 1.0 percent of the total active power transmitted along the circuit conductors at rated circuit current.
- 11) Any motor control centre (MCC) or motor for air conditioning installations, having an output power of 5 kW or greater, with or without variable speed drives, should also be equipped, if necessary, with appropriate power factor correction or harmonic filtering devices to improve the power factor to a minimum of 0.85 at motor and restrict the total harmonic distortion (THD). This may be achieved through use of capacitor banks.
- 12) All electrically driven equipment and motors forming part of a vertical transportation system should preferably comply with the energy efficiency requirements for lift and escalator installations.
- 13) Every motor having an output power of 5 kW or greater may be sized by not more than 125 percent of the anticipated maximum system load unless the load characteristic requires especially high starting torque or frequent starting.
- 14) A variable speed drive (VSD) shall be employed for motor in a variable flow application.
- 15) Motor users should insist on appropriate rewinding practices for any rewound motors.
- 16) Fix type capacitor should be used in capacitor bank to compensate inductive load of transformer.
- 17) The total power factor for any circuit should not be less than 0.85.
- 18) The power factor correction device should preferably be installed at the source motor control centre or distribution board just upstream of the circuit in question.
- 19) Office equipment and electrical appliances should have desired energy efficiency levels complying with relevant Indian Standards.
- 20) Consumers should be encouraged to select and purchase office machinery/equipment, for example personal computers, monitors, printers, photocopiers, facsimile machines, etc, complete with power management/energy saving feature.
- 21) Consumers should be encouraged to select energy efficient electrical appliances such as refrigerators, room coolers, washing machines, etc, complying with relevant Indian Standards.
- 22) Designers are encouraged to incorporate into their design all available latest demand side management (DSM) programmes in order to reduce the maximum demand and the electrical energy consumption in buildings.
- 23) All single-phase loads, especially those with non-linear characteristics, in an electrical installation with a three-phase supply should be evenly and reasonably distributed among the phases.
- 24) A system approach to measure and verify energy savings in the electrical distribution installations in buildings (especially high rise and commercial ones) should be adopted.
- 25) Wherever conventional fossil fuel based captive generation systems are deployed scoping for heat recovery systems, including tri-generation, may be explored.
- 26) To achieve peak demand avoidance programmable logic controller (PLC) controlled automatic electrical distribution systems should be opted for.
- 27) Consumers should be encouraged to use IE2/IE3 motors in line with accepted standard [11(34)] and replace old inefficient motors with the mentioned standard. They should be

encouraged to replace the motors rewound more than 4 times.

- 28) Air handling units should use energy efficient motors.

11.10 Lighting

Lighting has a significant impact on building loads and energy usage. The lighting design should focus on providing high quality visual environment with an emphasis on energy efficiency. With efficient lighting technologies and moderated interior illuminance, it is possible to design high quality lighting at connected power level that are much lower than that in a conventional building. Renewable energy sources should be emphasized for lighting in the outdoor having access to ample sunlight.

11.10.1 Daylighting and Controls

The optimal use of daylight shall be made to reduce the load of the electric lighting system by dimming or switching off luminaires when natural light provides ample illuminance for the task performed in the space. Daylight harvesting has a significant energy saving potential if it is integrated with the building design after comprehensive understanding of site, building orientation, weather conditions, materials and system design. Design for daylighting shall be done in accordance with Part 8 'Building Services, Section 1 Lighting and Natural Ventilation' of the Code. It is recommended to explore use of automatic light controls like those based on occupancy, timer, and dimmer.

11.10.2 Artificial Lighting

Lamps, luminaires, ballasts and the controlling systems should be monitored for achieving energy efficiency through artificial lighting. Factors that play crucial role in designing an energy efficient lighting system are:

- a) Reflectance,
- b) Design of interior spaces,
- c) Efficiency of lighting systems,
- d) Task lighting,
- e) Controlling systems, and
- f) Monitoring and maintenance.

Reference may also be made to the National Lighting Code.

11.11 Lifts, Escalators and Moving Walks

To minimise the environmental impact, the materials used for manufacture of lifts, escalators and moving walks should be recyclable, shall not have a potential for depleting ozone layer, shall not be hazardous, and shall be easily disposable at the end of life cycle. As power consumption during utilization phase has the maximum environmental impact, lifts and escalators to be installed shall be energy efficient.

In case of high rise buildings with multiple lifts having peak traffic demand, to increase the efficiency, the destination control system wherein passengers key-in their destination before entering the elevator, which optimizes the number of trips made by the lifts, may be installed. The controller groups the people such that the stops are minimised and travel time reduced.

Electrical traction lifts should be preferred over hydraulic lifts. Use of high efficiency motors such as permanent magnet synchronous motors, or induction motors having minimum efficiency class equivalent to IE2 as per accepted standard [11(34)] is recommended. The brake liner material should be environment friendly.

It is also recommended to provide lifts with regenerative drives. The efficiency of the drive in both motoring and generating mode should not be less than 0.8. LED lights should be preferred for illumination.

The planning, design and installation of lifts and escalators shall be done in accordance to the Part 8 'Building Services, Section 5 Installation of Lifts, Escalators and Moving Walks' of the Code.

11.12 Good Installation Practices

For installation of equipment and other installations, good installation practices with stringent quality control measures should be followed which also results in easy maintenance and energy saving, subsequently.

11.13 Commissioning and Handing Over

Commissioning is a systematic process to ensure that the installed systems perform according to the design intent and the owner's operational needs. A commissioning plan should be created early in the design phase. The readings should be logged and tabulated properly. The operation and maintenance staff shall be adequately trained by qualified personnel so that the staff has all the information and skill needed to optimally operate and maintain the systems. Operation and maintenance manuals with as-built drawings should be obtained from the contracting agency/agencies.

11.14 Operation and Maintenance

The operation and preventive maintenance schedule should be diligently complied with. Operation should be specially focussed, from sustainability point of view, in areas which can result energy saving. Such savings shall be aimed at without compromising the design intent.

11.15 Ongoing Performance

Regular maintenance and cleaning, periodic calibration, monitoring emissions and leaks, purge operation, record keeping, proper refrigerant levels, etc, help in continued peak performance of operation.

11.16 Renewable Energy

All efforts should be made to utilize in the building, the renewable energy available in various forms. Following aspects may be considered for the purpose:

- a) *Solar energy utilization* — Solar energy may be utilized in building through the following applications:
 - 1) *Solar water heating systems* — Hot water requirement in buildings may be met through use of various types of solar water heating systems. Major types of water heating systems are:
 - i) Flat plate collector: Single glazed, double glazed;
 - ii) Evacuated tube collectors; and
 - iii) Water heating with solar concentrators.

Considering the possibility of overcast conditions, or maintenance of collector, etc, the solar water heating system should be fitted with auxiliary heating system using conventional sources of energy such as electricity or gas. Application of auxiliary heating should be determined in such a way to avoid heating of excess amount of water. For example, if the heating is provided in a tank, it keeps the entire amount of water at the set point temperature, irrespective of the requirement/usage, resulting in wastage of energy.

In case of buildings where roof area is not sufficient to cover entire requirement of solar water heating, especially in case of high rise buildings, solar concentrators may be used for focusing solar energy over smaller area.

Decision about single glazed, double glazed, evacuated tube, concentrating type, etc, shall be done as per the local site conditions, solar radiation, ambient temperature, wind velocity, shading of neighbouring buildings and other similar features.

Capacity of such systems should be determined as per the average requirement instead of peak requirement, as the later increases the investment involved and reduces the financial payback period.

- 2) *Solar steam systems for cooking, laundry, etc* — Steam can be generated on the roof top of buildings through use of solar concentrators. Steam generated through

such concentrators can be used to meet requirement of steam in buildings such as for cooking and laundry, and to meet the energy demand for other applications such as for heating/preheating of air and disinfection/sterilization of instruments. Specifications of such systems shall be determined according to availability of solar radiation, size and concentration ratio of the concentrator, ambient temperature, and steam storage for operation during off-sunshine hours. Wherever such systems are used/installed, attempts should also be made to recover condensate or warm water after its application.

- 3) *Solar assisted refrigeration/air conditioning systems* — It should be also attempted to utilize solar energy to operate vapour absorption or vapour adsorption based refrigeration/air conditioning systems. Similar to solar water heating systems, such systems may also be designed with auxiliary heat supply provisions so that they may also operate during overcast days.
- 4) *Solar photovoltaic systems* — Solar photovoltaic (PV) systems are direct energy conversion systems that convert solar radiation into electric energy. Roof of buildings as well as other exposed areas such as of parking shade, can be installed with solar PV system. Major considerations while designing a building integrated PV system are:
 - a) Sufficient spacing between consecutive rows of modules as per the sun-path diagram;
 - b) Inclination of modules to match requirements as per latitude;
 - c) Periodic cleaning of dust from the cover of modules;
 - d) Matching of specifications of PV modules, array, power conditioning unit (PCU)/inverter, battery storage and wiring; and
 - e) Checking of operating point of PCU/inverter, depth of discharge of batteries.

Components of solar PV systems and factors of performance are as follows:

- i) *PV modules* — These contain solar cells. Efficiency of cells and module should be as high as possible. Currently, cells having 16 percent efficiency are commonly used and suggested.

- ii) *Charge controller/inverter/PCU* — It is part of PV system that matches the output of PV modules with acceptable form of electricity by battery bank or load or grid. Since considerable power loss may take place in this unit, efficiency of inverter/PCU should be more than 90 percent at full load and not less than 85 percent at 25 percent load.
- iii) *Battery bank* — It is where energy can be stored in batteries for use during off-sunshine hours. When operating in stand-alone mode, usually additional one day energy storage capacity is provided in the battery bank. Location and type of batteries should be such that they do not affect indoor air quality. If kept indoor, the space should be sufficiently ventilated with fresh air with no recirculation of air.
- b) *Wind energy utilization* — If sufficient wind velocity exists at the site, it should be attempted to make use of available wind velocity through installing wind turbine for power generation. Usually wind velocity increases with height, hence wind turbines may be installed on the roof of high rise buildings or between two buildings causing Venturi effect due to their shapes, with due care towards structural safety considerations. Hourly wind data of whole year at the site should be the basis of machine selection, and not just wind velocity during few days of the year.
Annual power output from the turbine should be more than power output equivalent to full load output for 20 percent of the whole year. However, exact number in this regard shall be governed by the cost of wind turbine, cost of electricity and other case specific variables. The visual disturbance caused by the rotating wind turbine, acoustic disturbance to neighbouring area and to occupants of buildings should be considered while selecting machine and its location.
At some locations where wind and solar radiation both are available, and especially when wind is available during the time when there is no or less solar radiation, hybrid wind-solar PV systems can also be considered. Wind energy systems may also be operated in hybrid mode with other sources of electricity such as diesel generating (DG) sets to ensure availability of power throughout the year.
- c) *Waste utilization* — It should be attempted to make full utilization of all wastes, especially

waste heat and bio-degradable solid waste.

- 1) *Waste heat utilization* — Waste heat available from different sources such as exhaust gases and cooling water of electricity generators, or any other process going on in the building that discharges solid, liquid or gaseous hot waste, may be utilized directly through heat recovery methods for heating applications such as space heating, service hot water, etc. Alternatively, the waste heat available can also be utilized for operating vapour absorption or vapour adsorption refrigeration/air conditioning systems.
- 2) *Solid waste utilization* — Bio-degradable solid waste generated within the building, such as kitchen waste, human excreta, branches and leaves of trees, grass cuttings should be utilized through anaerobic digestion process to produce combustible gas. This gas may be utilized to replace some fuel requirement in the building. Manure is a by-product of such bio-gas digester that may be used to improve the economics of utilizing solid waste. Other alternatives of anaerobic digestion, such as briquetting for direct combustion, gasification may also be used as per properties and availability of solid waste.
- d) *Bio-fuels* — The term bio-diesel or bio-fuels is usually referred to liquid fuels that are not obtained from fossil based sources of energy such as crude oil, but are obtained from plant species.
In case of buildings where open space is available, attempts should be made to grow such plants and use their oil to substitute some of the conventional fuel. For example, DG sets may use a blend of bio-diesel and diesel or may even operate on 100 percent bio-diesel. Similarly, other possibilities of obtaining combustible fuel, such as from vegetable waste oil of restaurants and hotels should also be explored and utilized, wherever possible.
- e) *Hydropower* — The flow of tides of an ocean or a stream is harvested to produce hydropower. As the water is released from the upper reservoir to the lower reservoir it generates power using the hydro-kinetic energy of the water flow through a generator. The ability to use hydropower is limited on an individual building scale. On rare occasions, buildings can take advantage of

streams to generate hydropower on site.

- f) *Other renewable energy sources* — Depending upon climatic location and site specific features, possibility of exploiting other renewable energy sources, such as, geothermal heating and cooling systems should also be considered.

12 CONSTRUCTIONAL PRACTICES

The framework for sustainable construction practices includes the following issues:

- a) Pre-construction pre-requisites;
- b) Planning for sustainable construction;
- c) Preparation of sustainable construction management plan;
- d) Planning, monitoring and control of environmental descriptors;
- e) Sustainable work execution procedures;
- f) Effective use of water;
- g) Construction waste management ;
- h) Post-construction closeout;
- j) Construction methodology for heritage buildings; and
- k) Alternative use, de-construction, dismantling, demolition.

12.1 Pre-Construction and Pre-Requisites

Sustainable construction bears upon developing the design proposal, which is efficient in terms of functional performance as well as detailed out to ensure that the material resources and construction technologies are used efficiently during construction stage. Frequent changes to the design during construction stage often lead to wastage and other resources, rework and redundant handling and construction processes. Construction practices to execute design proposals, which inherently cause higher wastages and do not facilitate efficient planning, should be avoided. The pre-construction stage proposal development should incorporate certain pre-requisites that lead to sustainable construction practices (*see also 12.4*).

12.1.1 Architectural and Structural Design

Architectural design should be detailed out so that use of materials and technologies may be planned in advance. Design detailing should facilitate planning of procurement of materials in sizes, volumes and lots, such that the wastage during construction is least. It is desirable that the design is consistent with the available material sizes, shapes and volumes. Design should, therefore coordinate to incorporate quality and quantity aspects from the point of view of construction.

Design detailing should facilitate procurement process. Storage of materials at site for unduly long period may adversely affect its quality and short supply may lead to interruptions in interfacing activities. Thus, the efficient procurement process ensures optimum procurement.

Structural design is critical in ensuring optimum use of materials. Inadequate rigour in design analysis can lead to over-sizing of structural members, while uncertain quality assurance and control may render structural members unsuitable due to permanent construction defects.

It may be desirable to develop building designs through digital models so that the dimensional coordination and interfacing between architectural, structural and engineering services is ensured with an aim to avoid improper execution during construction stage. Application of ‘modular coordination’ is desirable in mass repetitive construction works especially using mechanized or industrialized construction techniques.

Drawings generated as ‘good for construction drawings’ shall be reviewed for coordination across various disciplines before their release for construction. Coordination between architectural drawings, structural drawings and engineering services (mechanical, electrical, plumbing) drawings, etc, shall be assessed in plans and sectional details. It may be desirable to undertake three-dimensional clash analysis using appropriate information technology tools and software. Therefore, all efforts should be made at design stage to ensure that the time and resources are not wasted during construction stage work.

12.1.2 Inclusion of Sustainable Construction Needs in Feasibility Report

Feasibility report directs planning, design and execution of a project. It acts as a reference boundary for the project within which the project is viable. It details out the manner in which objectives of the project are achieved. Project requirements shall be accomplished within the planned resources. In light of the significance of feasibility report, is it essential that the sustainability objectives, both in terms of operational phase of the project as well as the construction phase, should be highlighted. As a result of that, the resources, technical procedures and benchmarks may be established for execution to be viable within the overall sustainability parameters of the project.

Specifically, benchmarks for the energy consumption, water utilization, waste generation, reuse of waste generated during construction and operation phase should be established in the feasibility report for sustainable construction.

12.1.3 Construction Methodology

For sustainable construction practice, it is essential that the physical execution of works should only be undertaken when the construction methodology is established, and reviewed for its reliability under the risk environment that may prevail under specific conditions of the project. Construction methodology details out process of execution, its work flow, deployment of various resources, planning for eventualities and contingency measures. In absence of an established sustainable construction methodology, the efficacy of work procedures may not be ensured.

It is desirable to evolve construction methodology on digital models so the physical developments at site may be simulated under working conditions. Information tools that identify inter-disciplinary clashes are identified. In many a cases, it may be necessary to plan in a predetermined manner for the structural considerations, failing which the stability may be jeopardized. It is essential for construction works that involve a fair amount of pre-fabrication, especially off-site, so that the fabrication is compatible and the installation procedures are fail-safe during the installation as well until the stage when structure is capable to endure itself independently.

12.1.4 Mitigation of Impacts Due to Materials and Technologies Deployed

Construction materials and technologies used at site may impact the environment, especially during processing of materials, such as cutting, mixing, fabrication, etc causing noise, dust and sometimes release of fumes. Such materials and technologies need to be identified and procedures planned to mitigate impacts.

12.1.5 Deployment of Plants, Equipment and Machineries

Selection of efficient plants, equipment and machineries and their proper scheduling of operation are key considerations for sustainable deployment. While selection, it is essential to ensure that plants, equipment and machineries have their performance ensured not in isolation but also when considered in relation to the supporting plants, equipment and machineries. For example, the selection of excavator of a certain capacity is linked to the availability to earth transportation out of site and the clear working space available for the excavator and the transportation vehicles. Having selected an optimum set of plants, equipment and machineries, it is essential that their operation is scheduled such that their combined performance is maximized. Failure to deploy plants, equipment and machineries in an efficient and effective manner may result in undesirable loss of fuel, and noise and air pollution.

12.1.6 Procurement Policy

In order to ensure sustainable construction, the organizations involved should have a resolve and commitment to procure processes, services, works and supplies that help in achieving the objective of sustainability. Since sustainability is project and context specific, the policy should entail requirements in respect of sustainability pertinent to the project.

12.1.7 Contractual Obligations towards Sustainable Construction

Contracts determine obligations of individuals and organizations. In this respect, the contracts shall make it obligatory on the part of the supplier (materials, equipment or services) to follow sustainable practices and processes. The scope of such obligations shall include the relevant issues described under 12. Contractually binding obligations ensure system-wide responsibilities so that necessary mitigation resources may be budgeted within the project scope.

12.1.8 Assignment of Responsibility for Sustainability Practices During Construction

The responsibility for sustainability practices during construction shall be clearly assigned, also explicitly assigning liabilities that may accrue on account of lapses. This strengthens the responsibility delegation and also act as deterrent for slackness while discharging duties. Liabilities may include contingencies for risks known as well as management reserves towards unknown risks.

12.2 Planning for Construction

Pre-construction pre-requisites are important inputs to the planning for construction in a sustainable manner. Planning processes describe the approach towards the construction. A proper planning, considering peculiarities of project, helps ensure successful execution. The planned processes towards sustainable construction may be far more effective than spontaneous actions taken without comprehensive planning at early stages. Also, cost for mitigations and possible alternative strategies for mitigation may be better analysed for arriving at managerial decisions.

12.2.1 Identification of Sustainability Issues During Construction

The procedure to identify sustainability issues during construction should include the areas of analysis given in 12.2.1.1 to 12.2.1.5 and other applicable concerns in respect of project scope and context of site and environment.

12.2.1.1 Construction methods review and impact on sustainability

Design details determine the construction procedures.

It is desirable to prepare a construction methodology and review the same from the point of view of its impact on the suitability to achieve quality, control of wastages, safety, resource optimization, energy conservation, water use, site contamination and pollution.

12.2.1.2 Consideration to environmental impact assessment

Environmental Impact Assessment (EIA) report systematically identifies the risks and impacts and recommends mitigation measures. Framework of EIA is defined in accordance with the statutory requirements and, hence, it is essential to consider the impacts so identified. Construction methodology and processes shall take cognizance of EIA report and environmental management plan (EMP).

12.2.1.3 Considerations to social impact assessment

Construction activities have significant impact on the socio-cultural interests of the populations surrounding the project sites. Continuance of human activities, especially related to their economic sustenance, livelihood and socio-cultural aspects, need special sensitivity. Dealing with social impacts during construction stage need managerial decisions to provide privileges to the affected populations and undertake actions to contribute towards deployment of social infrastructure. Such initiatives should be planned for.

12.2.1.4 Prevention and management of construction accidents

Accidents shall be prevented during construction stage. Construction teams shall analyse potential hazards and plan for their prevention and management. Accidents may endanger life of workers and population in and around the sites, cause disruptions to work and lead to loss of material and other resources. Efforts in prevention of accidents is often insignificant as compared to the problems in facing consequences. Deep excavation, scaffolds, shuttering and hoisting operations are known to be prone to accidents at sites. In addition to the accidents that may be caused due to the activities on site, there may be environmental conditions that may cause accidents during construction works since works may not have attained the stage of adequate stability and endurance to counter the impinging environmental conditions. Accidents due to floods, landslides, cyclones, high winds and earthquakes may need special attention requiring proper disaster preparedness (*see also 12.11*).

12.2.1.5 Identification of training needs and workforce training

Sustainable construction practices require specific processes to be followed in respect of planning, monitoring and control. Involvement of workforce at

all levels need training to deal with sustainability issues during construction. Project management functional responsibilities shall include identification of processes, competencies of persons involved in discharge of such duties, assessment of performance and conduct training programme. The effectiveness of training programme shall be assessed through performance appraisal system and corrections made as needed. Training need assessment frequency should be determined based on the type of work and the human resource competencies.

12.3 Preparation of Construction Management Plan

Having identified sustainable issues specific to the project, a comprehensive planning needs to be documented in a management plan. The management plan documents the approach to site management, project management processes, systems for management, site organization, data inputs to determine effectiveness of management systems and site planning.

12.3.1 Establishment of Construction Project Management Processes

Objectives of sustainable construction can only be realized through effective project management processes. Time, cost, quality, scope, risk, procurement, human resource, health and safety are some of the basic project management processes that shall be elaborated. Reference should be made to good practices [11(29)] for detailing out construction project management processes.

12.3.2 Establishment of Management Systems

Management systems define organizational commitment, organizational structure, resource allocation, relevant critical planned processes, procedures for monitoring and control to ensure continual improvement. The approach of management systems is preventive with an objective to achieve excellence in terms of absence of non-conforming works. Management systems approach sustains on documented voluntary initiatives, due monitoring thereof, and the same way be considered. Reference should be made to appropriate Indian Standards for developing and complying the above systems.

12.3.3 Establishing Site Organization Structure

Establishing site organization structure, considering management systems and involvement of other agencies in construction, is very critical. Interfaces across various agencies involved in construction need clarity for effective coordinated decisions which can lead to prevention of wastage of resources, reworks, rejections, delays and such other non-conformities detrimental to quality of work and delay in execution.

12.3.4 *Establishing Energy Consumption Data Collection, Analysis, Documentation System and Creating Benchmarks*

Monitoring of performance of management systems and processes of execution need establishment of indicators so that specific improvements may be achieved. In this respect, energy consumption monitoring is fundamental. At construction sites, electricity and diesel are primary sources of energy and their consumption shall be monitored so as to improve methods and the operation of equipment is energy efficient. Data collected should be analysed with respect to processes of significance in terms of consumption and pollution. Database so generated can also be used for establishing project specific, organization specific or process specific benchmarks for future reference. Appropriate documentation of fuel consumption logs, energy metering and execution processes shall be planned and assigned organizational responsibility. Site management decisions shall take cognizance of energy consumption data.

12.3.5 *Overall Construction Site Planning*

Improper site planning is often reason for redundant material handling, processes involving unnecessarily long lead, wastage during multiple handling, inefficient deployment of equipment, etc. Circulation and movement of workers and visitors can be reason for unsafe working conditions. Following issues, therefore, need specific attention while undertaking site planning:

- a) Layout of roads and services;
- b) Deployment of plants, equipment and machineries;
- c) Location of temporary structures, fabrication area and storage areas;
- d) Work area demarcation and safe surrounding;
- e) Emergency plan and medical facility;
- f) Control of site dereliction;
- g) Prevention and management of top soil; and
- h) Storage of chemicals, fuels and explosives.

12.3.6 *Location of Infrastructure for Labourers*

Labour is at the bottom of the organizational structure of construction practices. Project organizations may tend to ignore the interests of labour and tend to be indifferent to their needs. Indifferent and ignored labour, on the other hand, can cause inherent inefficiencies in the system and lead to unreliable performance. Infrastructure for labour needs to be planned and budgeted suitably considering the following:

- a) Compliance to labour laws including *Building and Other Construction Workers (Regulation of Employment and Conditions of Service) Act, 1996*;
- b) Policy and location of labour camps;
- c) Policy for deployment of labour from local

communities;

- d) Labour movement;
- e) Social infrastructure for labour;
- f) Health, hygiene, amenities and waste disposal; and
- g) Training need assessment, training infrastructure and effectiveness monitoring.

12.3.7 *Setting Up of Health and Hygiene Infrastructure*

Health and hygiene infrastructure is needed for the construction site as well and the labour infrastructure, especially if labour camps are off site. In addition to the construction project specific injury and emergency treatment facilities, facilities shall be provided for conducting periodic health check-ups for the workers so that the effects of construction activities on the health are monitored. Medical facilities shall be established with suitable expert physicians and paramedics, availability of appropriate medicine supplies, diagnostic facilities and organized record keeping.

As a part of hygiene infrastructure, potable water supply, waste water disposal and solid waste disposal (non-construction) are planned in a proper manner. In order to determine the standards, the needs of vulnerable groups, such as children, shall be considered.

12.3.8 *Location of Facilities for Hazardous Materials*

In special cases, the facilities for storage of hazardous materials may be provided very carefully. There may be a case for locating such facilities off-site. Specific statutory guidelines in respect of such requirements shall be referred to. The facilities and the handling procedures shall be well established.

12.4 **Planning, Monitoring and Control of Environmental Descriptors**

Environmental impact assessment (EIA) undertakes characterization of the existing status of the land, water, air, biological and socio-economic environment in the project area and its surroundings. It seeks to identify potential environmental impacts of the project, and formulation of an effective environmental management plan (EMP) to prevent, control and mitigate the adverse environmental impacts, and ensuring the compliance with the environmental legislations. Thus, the scope for planning, monitoring and control of environmental descriptors during construction phase is identified and described in the EIA and EMP. Construction agencies shall develop further and detail out their respective compliance requirements accordingly.

Depending on the nature of project, construction agencies shall be required to establish infrastructure and procedures for soil monitoring, water quality

monitoring, ambient air quality monitoring, noise monitoring, tree counting and traffic survey, with a view to having required controls thereon.

12.4.1 Soil Monitoring

Soil samples from representative locations in the site and study area shall be collected and analysed for important relevant physical and chemical parameters. Soil monitoring should be carried out in at least three locations including one at the project site.

12.4.2 Water Quality Monitoring

Water quality monitoring shall be conducted at representative locations in the study area for surface and groundwater. Samples shall to be collected and analysed for important relevant physical, chemical and bacteriological parameters. Water quality monitoring locations should include at least three surface water (if exists in the study area) and three groundwater locations.

12.4.3 Ambient Air Quality Monitoring

Depending upon the project size, location and the type of activities involved, ambient air quality in respect of suspended particulate matter (SPM), respirable particulate matter (RPM), SO₂, NO_x, and CO, shall be monitored at representative locations in the site and study area at a frequency of twice a week at each location adopting a 24 hourly schedule (8 hourly for CO). The monitoring locations shall be located on the basis of predominant wind directions, land use pattern and height of the proposed stacks. At least one station shall be located at the maximum pollution deposition area due to the proposed stacks of generators. The number of air quality monitoring locations should be at least five including one at the project site.

12.4.4 Noise Monitoring

Ambient noise level monitoring shall be carried out at representative locations in the site and study area over a period of 24 h to obtain hourly equivalent continuous noise (L_{eq}) levels as well as day and night time L_{eq} to compare with the standards. Noise monitoring should be carried out for at least six locations including one at the project site, one at the boundary of the project site and one at the nearest residential/sensitive area.

12.4.5 Tree Counting

Survey shall be conducted to assess existing trees in the project site in respect of numbers, species girth size, plan for re-plantation or making good for trees being lost to be finalized.

12.4.6 Traffic Survey

Traffic survey for continuous 24 h has to be carried out to measure number and type of vehicles passing on the existing main roads giving access to the project.

12.5 Work Execution Procedures

Work execution procedures should be described in a manner so that there is least wastage, rework and repair and acceptable performance is achieved. In this respect, the reference to relevant Indian Standards for materials; quality assurance verification; material handling, storage, and protection; work procedures including working on materials/fabrication, placing/installation; inspection and testing procedures of completed works; and protection after completion of work, need to be specifically addressed. In addition to these considerations, the relevant works should be given specific attention as given below:

- a) *Excavation and sub-structure works* — Issues related to noise and vibrations during excavation, piling, rock cutting, etc; control of damages to surroundings; prevention of collapse; and, control of excessive dewatering and sustainable use of de-watered water need to be analysed, risks identified and methodologies detailed out prior to undertaking such works.
- b) *Concrete work procedures* — Soundness and stability of formwork and other enabling structures; suitability of concrete mix to the prevailing environmental conditions; avoidance to undesirable cutting, etc for laying services and embedded items; providing requisite cover to the reinforcements; proper curing; and, allowance of setting time are essential for meeting the expected performance of concrete works. In general, for concrete works, good practices [11(30)] shall be followed.
- c) *Steel, aluminium and other metal works* — Noise control during cutting, welding, hammering and fabrication operations; prevention of waste; reuse of cut sections (for example cut reinforcement bars reused in other locations depending on requirement); collection and disposal of scrap; fire and injury prevention during working; prevention of collapse due to unstable installation operations; and safety of workmen are critical aspects that need special mention in procedures.
- d) *Masonry works* — Wastage during on-site handling of materials; execution in proper plumb, plane and alignment to avoid wastage of finishing material for making up for making up for the defects; and, filling up of joints to attain requisite U and R -value characteristics need particular attention.
- e) *Surface finishing and furnishing* — Preparation of finishing base; environmental

conditions during and after finishing/furnishing works; and, application procedure for surface undulations are essential considerations to realize desirable surface characteristics as well as service life of finishes and furnishings.

- f) *Handling and use of chemicals* — Working conforming to the prescribed procedures; protection against spillage and human body contact; supply and use log describing quantities and authorized person(s); and, prevention of reaction which are explosive, exothermic causing fire or release of toxic fumes or creating corrosive reactions to the surrounding works, should be specifically identified and planned.
- g) *Handling and use of oils and gases* — Avoidance of fire by preventing conditions leading to ignition; spillage polluting the works and sites; use of appropriate containers for storage and handling; and contingency procedures for limiting damage due to spillage and neutralizing the effects should be specifically highlighted in procedures.

12.6 Effective Use of Water

See 10.4.

12.7 Construction Waste Management

12.7.1 Construction and demolition activities generate large quantities of solid waste. Diversion to landfill sites is one of the major issues in handling of construction waste. Increase in waste generation and improper land filling with construction wastes have major impacts like waste of land resources, affecting water bodies, groundwater pollution, etc. Construction organizations shall systematically pre-empt and identify wastes that may be generated and plan to re-use, re-cycle and handle wastes in an appropriate manner. Monitoring of waste and its disposal through an established procedure also create opportunities to prevent wastages in construction processes and lead to conservation of resources.

By proper disposal, waste materials which are likely to be dumped in landfills can be converted into value added products. Some construction waste materials can be diverted for re-use, whereas others can be recycled into another usable material. Many construction waste materials can either be used onsite or sent to other nearest sites/industries for reuse/recycle/reconversion into useful products.

One of the important approaches to reduce waste and effect waste utilization is to evolve design details such as optimizing use of materials and employing technologies aiding in the same. Durable materials and high performance technologies need lesser maintenance

and deliver better service life. Proper construction waste planning is, therefore, recommended before starting the construction or demolition which involves identification, segregation, proper storage, reuse/recycling and finally the proper disposal of remnant waste materials.

12.7.2 *Identification, Segregation and Storage of Wastes*

It is very difficult and costly to reuse or recycle the waste materials which is in mixed form and not segregated at right time during the construction. Storing of segregated waste in labelled containers/bins, and monitoring of stored waste bins periodically by the trained/skilled personnel may prevent wastage. Waste should be stored within the site and such area should be chosen, where further shifting is not required.

12.7.3 *Reuse and Recycling*

Reuse and recycling not only reduces the land filling load but is also economical and an eco-friendly step in construction. Reuse increases the life of building materials. It is desirable to locate nearby recycling units for construction waste recycling to reduce the cost as well as adverse environmental impact.

Brick bats and concrete, especially from piling works, have a potential to be used as sub-grade works for paving, etc. Excavated earth and boulders may often be reused at site or used elsewhere through the network of specialist agencies. However, topsoil should be isolated, preserved and reused at the same site or at another location where there is a demand for fertile topsoil for landscaping. Wastes, such as metal and plastics, should be disposed of for re-cycling. Other wastes, such as cellulosic materials, timber, etc, which are biodegradable, should be disposed of at authorized designated locations.

12.7.4 *Handling and Disposal of Waste*

All construction wastes shall be stored or handled in such a way so as to avoid unnecessary decay or deterioration. Bio-degradable waste during construction shall be collected separately and treated with bio-methanation, organic waste compactors, etc, or subjected to composting.

Construction waste is generally inert in nature (does not contain chemical or biochemical pollution), but proper training is required to handle the construction waste because improper handling may cause accidental damage to the handling person. The person segregating the construction waste should be properly equipped for safety aspects. Spillage of construction waste during transportation should be prevented. There are different sustainable techniques of waste disposal available and should be practiced.

12.7.5 Every waste resulting from construction,

remodelling, repair and demolition of any civil structure of individual or organisation shall be managed in accordance with *Construction and Demolition Waste Management Rules*, 2016.

12.8 Post-Construction Closeout

Project closeout is a very significant stage from the sustainability considerations. While project management closeout should ensure that the contractual obligations are complied with, the consequences of construction activities should also be appropriately determined. At this stage, the obligations of the project, in terms of physical delivery of works as enshrined in the briefing documents as well as environmental commitments towards sustainability, shall be ensured.

12.8.1 Disposal of Structures and Infrastructure for Construction

Building and other structures and other infrastructures may need to be demolished/reconstructed partly or completely. These, including their mechanical, electrical, plumbing installations, etc, should be disposed of in a manner so as to facilitate re-use of materials, components, installations, etc, by the same organization at another construction site or their recycle. In case the materials do not have reclaim value, possibility should be explored for their use as backfill materials; otherwise offsite disposal may be resorted to in an appropriate and authorized manner.

12.8.2 Closure of Tube Wells

Abandoned tube wells are a risk to life. These shall be closed properly. In may also be explored to reuse the same as a part of water harvesting system.

12.8.3 Restoration of Dereliction Caused to Site

While controlled site dereliction is a good construction practice, the site should be restored deploying appropriate methods. Project budget should include apportionment of resources towards restoration. Such restoration activities may continue for a long time even after physical completion of project, and hence, the commitment towards such efforts is essential. It shall be ensured that the areas, which are under restoration, are well protected during this period.

12.8.4 Re-Use of Top Soil

Re-use of top soil as a resource is an important sustainability consideration. In case the construction site does not leave adequate space for storage of top soil, it is important to identify another location in vicinity for proper storage until it can be reused at the same site or in case it is found not possible to use in the same site, it is taken to other nearby site for use as top soil. Value of top soil should not be compared in financial terms but rather as a scarce natural resource.

12.9 Heritage Buildings and New Construction

Heritage buildings should be given special attention during construction of a new building, especially if it is situated in close vicinity, complying with the requirements of proper architectural controls in accordance with **18** of Part 2 'Administration' of the Code. The following may also be considered while planning and executing such works:

- a) Heritage contents, their characteristics and other building elements that need to be undertaken as scope of work.
- b) Construction techniques including diversion of utility services.
- c) Competence and experience of execution agency to handle such works involving the use of traditional materials and technologies.
- d) Approval of structural and chemical investigation and local understanding, of the heritage structure if it has merit of cultural significance.
- e) Project management processes especially pertaining to time, cost, procurement and risk assessment, risk management and risk preparedness strategy, using the sequences appropriate to traditional works.
- f) Scheduling of activities including review processes and inspections by designated competent persons.
- g) Planning for enabling works and safety such as scaffolds, protection measures for other adjoining works.
- h) Site management including circulation diversions.
- j) Contingencies for unexpected damages to works and unforeseen structural behaviour.
- k) Prevention of fire, flooding and other such emergencies and disasters during works.

12.10 Alternate Use, Deconstruction, Dismantling and Demolition

Built facilities are created to facilitate certain functions. Due to changes in functional use over a period, deterioration in physical condition of building elements, etc, the productivity may decline below threshold. As a result such buildings may be rendered unsuitable in spite of previous renovations. In such situations, effort should be made to re-use of facilities with renovations or remodel for alternate use retaining most of the building and its facilities. Effort may be made to evolve a flexible design so as to make it suitable to varied functional uses.

If design configuration and residual service life is not consistent with functional requirements and particularly

considering the safety of the building, the built facility should be de-constructed so as to retrieve as many buildings assemblies/materials/installations for reuse and recycle, as possible. While working on design details, it shall be ensured that the design should facilitate deconstruction. During the process of de-construction, least damage should be caused to the assemblies, materials and installations. In case of complex structure, such operations shall be undertaken under expert supervision and with proper enabling works.

If built facilities were not designed to facilitate deconstruction, the dismantling should be resorted to in such a manner as to maximize retrieval of materials. Demolition operations shall be planned considering safety of workers; and avoiding damage to adjoining properties; noise, vibrations and air pollution; disruption to continuance of activities in the vicinity; etc. The demolition shall be carried out in accordance with good practices [11(31)].

12.11 Disaster Risk Mitigation during Construction

Sustainable construction practices shall address risks during construction stage from natural and man-made disasters. Natural disasters such as earthquakes, landslides, cyclones, flooding, etc, shall be considered during construction planning and adequately taken into consideration in risk mitigation through the construction methods statement, generally developed by the construction project management team and/or construction agency. Reference shall also be made to Part 6 'Structural Design' of the Code for technical measures for natural disaster mitigation.

In addition to the natural disasters, the risk mitigation against man-made disasters shall also be carried out. Deep excavations causing cave-in due to the lack of proper protection, earth saturation caused due to leaking city sewers/water mains are common man-made disasters. Similarly, fire collapse of structural slabs leading to progressive collapse of slabs below, hoisting of space frames, trusses and concrete segments and operations involving coordinated lifting/hoisting using multiple cranes are some typical situations that may turn disasters. Such operations and processes should have 'fail-safe' detailing as also back-up plan to deal with disasters. Necessary resource deployment shall be part of such disaster planning.

Reference shall also be made to Part 7 'Construction Management, Practices and Safety' of the Code for safety during various construction operations.

13 COMMISSIONING, OPERATION, MAINTENANCE AND BUILDING PERFORMANCE TRACKING

13.1 General

While the guidelines covered for commissioning and

handing over, operation and maintenance and building performance tracking are applicable to majority of building occupancy types, many of these are particularly suited to buildings with high energy consumption such as large office buildings, hospitals, hotels, retail malls, etc.

13.2 Commissioning and Handover

Commissioning of building services typically includes natural ventilation, renewable energy systems, metering installation, plumbing, lifts and HVAC systems commissioning, etc. Commissioning stage should record the consumption of energy (such as power consumed by fan motors) and water used by plumbing and other systems that will help in reviewing and improving the systems for efficient operation. The commissioning stage helps in identifying any remaining site activities and the training activities that need to be coordinated. It helps in bringing to attention various common problems encountered such as key pieces of hardware are missing, not installed, or defective; installation of sensors, scanners, and other monitoring devices in the wrong locations; and improper coding of the sequence of controls for equipment. These and other problems should be identified and corrected during the commissioning process. Required resources should be allocated to commission the systems after they are installed to ensure that they work as intended. A complete and thorough commissioning of the building shall be done to ensure that the systems will work as intended.

13.2.1 Commissioning Process

Typically, the first step in the commissioning process should involve formation of a commissioning team that comprises the owner, users, occupants, operation and maintenance (O&M) staff, and design professionals. The next step is the preparation of the project requirements, which should address building systems such as lighting, air-conditioning, water systems, etc, as well as the design intent and the functional specifications for the key building systems. The project design document should include a commissioning plan. Prior to the handover stage, the commissioning team should verify the installation of the systems, conduct functional performance testing, training of the O&M personnel, etc. A post occupancy commissioning report shall be provided to the owner and/or relevant authorities once the necessary tests have been conducted and the areas that need correction have been rectified.

13.2.2 Handover

During the handover stage, records of meter readings for the different building systems, and other data should be provided to the asset management team. A simple guide for occupants will help the team understand the working of the systems in the building.

13.3 Operation and Maintenance

O&M programmes that focus on improving energy efficiency of building systems can help save energy without a significant capital investment. From small to large sites, these savings can represent significant savings each year, and can be achieved with minimal cash outlays.

Building maintenance is a wide subject covering not only maintenance of building services but also the maintenance of all other aspects including the structure itself. Effective operation and maintenance is one of the most cost effective methods for ensuring reliability, safety and efficiency of a building. Inadequate maintenance of energy-using systems is one of the major causes of energy waste. Energy losses from steam, air and water leaks, uninsulated lines, maladjusted or inoperable controls and from poor maintenance are often considerable. Also, inadequate maintenance of systems that consume water, including plumbing, HVAC and landscaping systems (as applicable), can result in excessive usage of water. Good maintenance practices result in substantial savings in consumption of energy and water, and should be considered as a resource.

Traditionally, O&M is carried out on a reactive basis, where maintenance is only provided when equipment or systems fail. On the contrary, a preventative maintenance programme, that prescribes regular checks of equipment at scheduled intervals, helps to improve system performance and extend its useful life. Predictive maintenance programmes go a step further where rather than following a set schedule of maintenance, checks are used to predict when equipment may be in need of maintenance prior to it experiencing any damage. Such predictions are based on analysis of known factors, for example 'stressors' that can impact the performance of the system. The O&M plan should be complemented by a review of the building operation with one year after the majority of the building area has been occupied. The design and construction/installation teams should also review the O&M manual with the asset management team.

13.3.1 Requisites of an O&M Programme

A competent O&M programme requires the participation of staff from operations, maintenance, engineering, training and administration. The successful implementation of an O&M programme requires cooperation, dedication, and participation at all levels including among managers, practitioners, and other technical staff. The O&M plan should be a living document, that is, it is amended as the other requirements change. The intention should be to update O&M document periodically as new procedures and

technologies are developed and employed. A web-based version can also be implemented for incorporating updates as frequently as possible.

Revisions to the O&M programme should be considered throughout the assessment process while considering all potential energy savings, and also when capital-intensive projects are being evaluated. Changes to O&M procedures and practices should be considered beyond the scope of repair and regular maintenance. Auditors who conduct performance review of the facility should take a holistic approach, and should consider,

- a) how the activities that are undertaken within the building can be used to optimize energy efficiency in existing operations, and
- b) how the newly implemented measures can improve the performance of the building.

Activities related to O&M should be included in the implementation plan; responsibilities should be designated to individuals; and time lines should be outlined for completing these activities. Training of the staff and awareness programmes should be developed to ensure that there is full compliance among staff for the new procedures to ensure effective implementation of the energy efficiency programme. The O&M plan should refer to the manufacturer's recommendations on equipment operation and maintenance. O&M actions and activities should only be carried out by trained personnel.

13.4 Building Performance Tracking (Measurement and Verification)

Subsequent to the commissioning and handover stage, regular monitoring of the performance shall be carried out which will provide information on whether the set environmental performance and targets have been met or not. As part of the measurement and verification (M&V) process, an ongoing monitoring of the energy and water systems should be carried out. This will ensure ongoing accountability of energy and water consumption during the life of building. Some of the main attributes of a building performance tracking (measurement and verification) system include the following:

- a) Monitoring of technical and energy performance during first three to five years of occupancy, to ensure that the performance targets during the operation of the building are in line with the expected performance parameters. Energy metering may be provided for the following applications:
 - 1) Lighting (interior and exterior);
 - 2) Air conditioning (heating/cooling);
 - 3) Hot water systems;
 - 4) Renewable energy systems;
 - 5) Energy meters for pumping of municipal

- water, grey water and irrigation water; and
- 6) Miscellaneous equipment such as elevators, computers escalators, etc.
- b) Conducting an occupant survey annually for the first three years of the building. This will help in obtaining feedback from the users regarding the effectiveness of the designed systems, as well as identifying possible areas of improvement. These surveys will also provide information about any enhancements or modifications.

Monitoring the performance of plumbing, sanitation and irrigation systems in terms of the water consumed when the building is in operation is an important aspect of the performance tracking system. Metering the water consumed by these systems will help in determining whether the water consumption by the building is in an efficient manner or not. Similarly, measuring and tracking the discharge of water by the building, whether it is storm water, sewage, or otherwise, will provide information on whether the re-use of water is taking place efficiently or not (*see 10* for design of water efficient systems).

An energy management and control system (EMCS) is one method of tracking the performance of the energy consumed by the different building systems. EMCS systems typically consist of electronic devices with microprocessors and communication capabilities and utilize widespread use of powerful, low-cost microprocessors and standard cabling communication protocols. EMCS provides a building operator, manager or engineer with basic background information and recommended functions, capabilities, and best practices that will enable the control systems to be fully optimized, resulting in improved quality of life of building occupants and users and more reliable and energy efficient facilities.

13.4.1 Functions and Capabilities of an EMCS

An EMCS may be known as building automation system (BAS), building management system (BMS), energy management system (EMS), and facility management system (FMS). In this Part of the Code, the EMCS referred comprises the sensors, transmitters, data acquisition and data processing performed at the user (building) level as well as data and control systems that are more global to full campus control schemes. EMCS may also have a global supervisory controller to perform high-level tasks (for example, resetting temperature set-points based on building conditions and scheduling on/off times). The hardware generally consists of a distributed computer environment with smart controllers strategically located throughout the system (buildings and base-wide network). Several network terminals or computers can be attached to these networks to provide a man-machine interface (MMI).

Depending on its capabilities, EMCS can perform a wide variety of functions. At a minimum, the EMCS has a sensor(s) to measure control variable(s) (for example, temperature and flow rates), a controller with the capability to perform logical operations and produce control outputs, and a controlled device(s) that accepts the control signals and perform actions (for example, move dampers and valves).

13.5 Operator Skills and Training

Performance problems result from errors in installation and operation of complex building heating/cooling and other systems. Without the right skill sets and proper training, building operators and managers may not be able to manage the facility optimally even with the most advanced building management systems. One of the key ways to enhance building operations and maintenance performance and thereby achieving the efficiency goals of buildings/facilities is handling by well trained building operators and managers. To operate buildings efficiently, in addition to a good controls infrastructure, the following may be desirable:

- a) Increasing the skill level of operators and maintenance personnel; this can be accomplished by providing the building operators with frequent proper training and incentives for performing well.
- b) Providing adequate engineering supervision of work by technicians to ensure that knowledge of fundamental processes is properly applied for operation and maintenance actions.
- c) Providing operators with system performance feedback; this can be achieved by providing easy-to-use system diagnostic information to correct problems and to understand the cost impacts of improper operations.
- d) Providing incentives for achieving efficiency goals.
- e) Educating everyone who influences the decisions relating to planning, budget, design, and procurement of energy, water and related systems.

13.6 Control-System Maintenance

Maintenance of the control system is critical in ensuring its performance after installation and commissioning. Many factors can cause degradation of the control systems performance post-commissioning such as:

- a) Overrides of automatic control by operations staff, a frequent problem, generally driven by customer complaints;
- b) Drift or failure of sensors;

- c) Failure of actuators;
- d) Corroded or failed wires and their connections;
- e) Improper changes to control schedules (sometimes temporary changes become permanent changes by oversight); and
- f) Degradation or failure of controlled devices.

These problems can be prevented by good operation and maintenance practices, such as a reporting system for all overrides, periodic re-commissioning of the control system, and maintenance of the control system and the physical components it actuates. Automated fault detection and diagnostic tools, alarms, plots of trend data, and maintenance tracking systems may be used to help in identifying performance degradation, faults and the need for maintenance and for compliance

of recommendations of these tools and taking action, by the maintenance personnel.

It is recommended that the control system specifications include requirements for maintenance documents and a maintenance plan. The facility should also consider contracting for maintenance support, if it is not provided in-house. In procuring maintenance support, the organization should ensure that the maintenance contract requires maintenance of all systems in a manner that ensures continuous, or nearly continuous proper operation of all controls and controlled devices. This requires frequent, periodic inspection, testing, and evaluation of systems and equipment followed by the correction of any defects found. System inspection, testing and evaluation can be automated *via* continuous monitoring tools.

ANNEX A

(Clause 8.1)

DESIGN STRATEGIES AS PER CLIMATE ZONES FOR VARIOUS SEASONS

A-1 SUMMER PERIOD

<i>Design Strategy</i>	<i>Hot Dry Climate</i>	<i>Warm Humid Climate</i>	<i>Moderate Climate</i>	<i>Composite Climate</i>	<i>Cold Climate</i>
(1)	(2)	(3)	(4)	(5)	(6)
Reduction in the ingress of heat during the day (by insulation, thermal mass, buffer spaces, orientation, shading, etc)	√	√	√	√	√
Introduction of naturally (through use of courtyard, wind towers, properly positioned windows, etc) or mechanically pre-cooled air, into the building with adequate air-flow during the day	√	√ (substantive increase recommended)	—	√	√
Adequacy of airflow of naturally (through the use of courtyard, wind towers, properly positioned windows, etc) or mechanically pre-cooled air during the night	√	√ (substantive increase recommended)	√(naturally only)	√	√
Reduction of the temperature variation within the building during the day/night, in comparison to temperature variation in the ambient temperature	√	—	—	√	√
Adequacy air changes, as required by the activities within building, and the density of the occupancy	√	√ (substantive increase recommended)	√	√	√

A-2 WINTER PERIOD

<i>Design Strategy</i>	<i>Hot Dry Climate</i>	<i>Warm Humid Climate</i>	<i>Moderate Climate</i>	<i>Composite Climate</i>	<i>Cold Climate</i>
(1)	(2)	(3)	(4)	(5)	(6)
Reduction in the ingress of cold into the building during the day, as well as during the night (by insulation, buffer spaces, orientation, weather stripping, etc)	√	√	—	√	√ (substantive reduction recommended)
Reduction in the air changes, without compromising with the minimum requirements for the activities, as well as for the density of the occupancy	√	—	√	—	√ (substantive reduction recommended)
Reduction in the egress of heat from within the building spaces during the day as well as during the night	√	—	—	√	√ (substantive reduction recommended)
Adequacy of natural ventilation/air changes in all spaces, as per requirement of maintaining indoor air quality	—	√	—	√	—
Marginal reduction in the ingress of cold into the building during the day as well as during the night	—	—	√	—	—

A-3 MONSOON PERIOD

<i>Design Strategy</i>	<i>Hot Dry Climate</i>	<i>Warm Humid Climate</i>	<i>Moderate Climate</i>	<i>Composite Climate</i>	<i>Cold Climate</i>
(1)	(2)	(3)	(4)	(5)	(6)
Reduction in the ingress of heat from outside into the building (by insulation, thermal mass, buffer spaces, orientation, shading, etc)	√	√	√	√	√
Substantive increase in the airflow/velocity/air changes during the day as well as the night	√	√	√	√	√
Reduction of humidity within the building throughout the day and night (using dehumidifiers, desiccant cooling, etc)	√	√	√	√	√
Substantive increase in the natural ventilations in all spaces	—	√	—	—	—

ANNEX B

[Clauses 8.2(a), C-1 and D-1]

PRESCRIPTIVE METHOD FOR ENVELOPE OPTIMIZATION

B-1 ROOFS

Roofs shall comply with either the maximum assembly *U*-value or the minimum insulation *R*-value in Table 9. *R*-value is for the insulation alone and does not include building materials or air films. The roof insulation shall not be located on a suspended ceiling with removable ceiling panels.

Cool roofs with slopes less than 20° shall have an initial solar reflectance of not less than 0.70 and an initial emittance not less than 0.75.

Table 9 Roof Assembly *U*-Value and Insulation *R*-Value Requirements

(Clause B-1)

Sl No.	Climate Zone	24 h Use Buildings Hospitals, Hotels, Call Centres, etc		Daytime Use Buildings Other Building Types	
		Maximum <i>U</i> -Value of the Overall Assembly W/m ² C	Minimum <i>R</i> -Value of Insulation Alone m ² C/W	Maximum <i>U</i> -Value of the Overall Assembly W/m ² C	Minimum <i>R</i> -Value of Insulation Alone m ² C/W
(1)	(2)	(3)	(4)	(5)	(6)
i)	Composite	U-0.261	R-3.5	U-0.409	R-2.1
ii)	Hot and dry	U-0.261	R-3.5	U-0.409	R-2.1
iii)	Warm and humid	U-0.261	R-3.5	U-0.409	R-2.1
iv)	Moderate	U-0.409	R-2.1	U-0.409	R-2.1
v)	Cold	U-0.261	R-3.5	U-0.409	R-2.1

Table 10 Opaque Wall Assembly *U*-Value and Insulation *R*-Value Requirements

(Clause B-2)

Sl No.	Climate Zone	24 h Use Buildings Hospitals, Hotels, Call Centres, etc		Daytime Use Buildings Other Building Types	
		Maximum <i>U</i> -Value of the Overall Assembly W/m ² C	Minimum <i>R</i> -Value of Insulation Alone m ² C/W	Maximum <i>U</i> -Value of the Overall Assembly W/m ² C	Minimum <i>R</i> -Value of Insulation Alone m ² C/W
(1)	(2)	(3)	(4)	(5)	(6)
i)	Composite	U-0.440	R-2.10	U-0.440	R-2.10
ii)	Hot and dry	U-0.440	R-2.10	U-0.440	R-2.10
iii)	Warm and humid	U-0.440	R-2.10	U-0.440	R-2.10
iv)	Moderate	U-0.431	R-1.80	U-0.397	R-2.00
v)	Cold	U-0.369	R-2.20	U-0.352	R-2.35

B-2 OPAQUE WALLS

Opaque walls shall comply with either the maximum assembly *U*-value or the minimum insulation *R*-value in Table 10. *R*-value is for the insulation alone and does not include building materials or air films.

B-3 VERTICAL FENESTRATION

Vertical fenestration shall comply with the maximum area weighted *U*-value and maximum area weighted SHGC requirements of Table 11. Vertical fenestration area is limited to a maximum of 60 percent of the gross wall area for the prescriptive requirement.

Table 11 Vertical Fenestration *U*-Value and SHGC Requirements

(Clause B-3)

Sl No.	Climate	Maximum <i>U</i> -Value W/m ² C	Maximum SHGC	
			WWR ≤ 40 Percent	40 Percent < WWR ≤ 60 Percent
(1)	(2)	(3)	(4)	(5)
i)	Composite	3.30	0.25	0.20
ii)	Hot and dry	3.30	0.25	0.20
iii)	Warm and humid	3.30	0.25	0.20
iv)	Moderate	6.90	0.40	0.30
v)	Cold	3.30	0.51	0.51

Alternative overhangs and/or side fins may be applied in determining the SHGC for the proposed design. An adjusted SHGC, accounting for overhangs and/or side fins is calculated by multiplying the SHGC of the unshaded fenestration product times a multiplication (*M*) factor. If this exception is applied, a separate *M* factor shall be determined from Table 5 for each orientation and unique shading condition.

Vertical fenestration areas located more than 2.2 m above the level of the floor are exempt from the SHGC requirement in Table 11, if the following conditions are complied with:

- a) The total effective aperture for the elevation is less than 0.25, including all fenestration areas greater than 1.0 m above the floor level; and
- b) An interior light shelf is provided at the bottom of this fenestration area, with an interior projection factor (PF) not less than:
 - 1) 1.0 for *EW*, *SE*, *SW*, *NE*, and *NW* orientations;

- 2) 0.5 for *S* orientation; and
- 3) 0.35 for *N* orientation when latitude is less than 23°.

B-3.1 Minimum Visible Transmission (VLT) of Glazing for Vertical Fenestration

To permit the use of available day lighting in place of electric lighting, glazing products used in offices, banks, libraries, classrooms with predominant daytime usage, shall have the minimum VLT, defined as function of WWR, where effective aperture is greater than 0.1, equal to or greater than the minimum VLT requirements of Table 12. Table 12 also indicates recommended VLT

Sl No.	Window Wall Ratio	Minimum VLT
(1)	(2)	(3)
i)	0 - 0.3	0.27
ii)	0.31 - 0.4	0.20
iii)	0.41 - 0.5	0.16
iv)	0.51 - 0.6	0.13
v)	0.61 - 0.7	0.11

ranges for daylight applications in such spaces.

B-4 SKYLIGHT

Skylights shall comply with the maximum *U*-value and a maximum SHGC requirement of Table 13. Skylight area is limited to a minimum of 5 percent of the gross roof area for the prescriptive requirement.

Sl No.	Climate	Maximum <i>U</i> value (W/m ² °C)		Maximum SHGC	
		With Curb	Without Curb	0-2 Percent SRR	2.1-5 Percent SRR
		(3)	(4)	(5)	(6)
(1)	(2)	(3)	(4)	(5)	(6)
i)	Composite	11.24	7.71	0.40	0.25
ii)	Hot and dry	11.24	7.71	0.40	0.25
iii)	Warm and humid	11.24	7.71	0.40	0.25
iv)	Moderate	11.24	7.71	0.61	0.4
v)	Cold	11.24	7.71	0.61	0.4

ANNEX C

[Clause 8.2(b)]

TRADE-OFF METHOD FOR ENVELOPE OPTIMIZATION

C-1 The building envelope complies with the Code, if the building envelope performance factor (EPF) of the proposed design is less than the standard design, where

the standard design exactly complies with the criteria in Annex B. The envelope performance factor shall be calculated using the following equations:

$$EPF_{Total} = EPF_{Roof} + EPF_{Wall} + EPF_{Fenest}$$

where

$$EPF_{roof} = c_{roof} \sum_{s=1}^n U_s A_s$$

$$EPF_{Wall} = c_{Wall,Mass} \sum_{s=1}^n U_s A_s + c_{Wall,Other} \sum_{s=1}^n U_s A_s$$

$$EPF_{Fenest} = c_{1Fenest,North} \sum_{w=1}^n SHGC_w M_w A_w + c_{2Fenest,North} \sum_{w=1}^n U_w A_w + c_{1Fenest,Non North} \sum_{w=1}^n SHGC_w M_w A_w + c_{2Fenest,Non North} \sum_{w=1}^n U_w A_w + c_{1Fenest,Skylight} \sum_{s=1}^n SHGC_s A_s + c_{2Fenest,Skylight} \sum_{s=1}^n U_s A_s$$

and

EPF_{Wall} , EPF_{Fenest} = envelope performance factor for walls, fenestration and roofs, respectively;

and EPF_{Roof}

A_s , A_w = area of a specific envelope component referenced by the subscript 's' or for windows referenced by the subscript 'w';

- $SHGC_w, SHGC_s$ = solar heat gain coefficient for windows and skylights;
- M_w = multiplier for the $SHGC_w$ that depends on the projection factor of an overhang or side fin as given in Table 5;
- U_s = U -value for the envelope component referenced by the subscript 's';
- $c_{Roof}, c_{Wall,Mass}, c_{Wall,Other}, c_{Fenest,North}, c_{Fenest,Non North}, c_{Fenest,Skylight}$ = coefficients for the roof, wall, window and skylight class of construction. Values of c are taken from Table 14 to Table 18 for each class of construction.

Table 14 Envelope Performance Factor Coefficients — Composite Climate
(Clause C-1)

SI No.	Building Component	Daytime Occupancy		24 h Occupancy	
		U-Value W/m ² K	SHGC	U-Value W/m ² K	SHGC
(1)	(2)	(3)	(4)	(5)	(6)
i)	Mass walls	6.01	—	13.85	—
ii)	Curtain walls, other walls	15.72	—	20.48	—
iii)	Roofs	11.93	—	24.67	—
iv)	North windows	-1.75	40.65	-4.56	58.15
v)	Non-north windows	-1.25	54.51	0.68	86.57
vi)	Skylights	-96.35	311.71	-294.66	918.77

Table 16 Envelope Performance Factor Coefficient — Warm Humid Climate
(Clause C-1)

SI No.	Building Component	Daytime Occupancy		24 h Occupancy	
		U-Value W/m ² K	SHGC	U-Value W/m ² K	SHGC
(1)	(2)	(3)	(4)	(5)	(6)
i)	Mass walls	6.42	—	9.60	—
ii)	Curtain walls, other walls	14.77	—	19.71	—
iii)	Roofs	9.86	—	14.11	—
iv)	North windows	-1.58	34.95	-7.29	64.19
v)	Non-north windows	-1.00	43.09	-6.48	76.83
vi)	Skylights	-96.11	305.45	-295.45	893.55

Table 15 Envelope Performance Factor Coefficients — Hot Dry Climate
(Clause C-1)

SI No.	Building Component	Daytime Occupancy		24 h Occupancy	
		U-Value W/m ² K	SHGC	U-Value W/m ² K	SHGC
(1)	(2)	(3)	(4)	(5)	(6)
i)	Mass walls	5.48	—	15.01	—
ii)	Curtain walls, other walls	6.38	—	22.06	—
iii)	Roofs	11.14	—	25.98	—
iv)	North windows	-2.40	36.57	-1.49	56.09
v)	Non-north windows	-1.86	46.79	1.187	81.79
vi)	Skylights	-96.27	309.33	-295.81	923.01

Table 17 Envelope Performance Factor Coefficient — Temperate Climate
(Clause C-1)

SI No.	Building Component	Daytime Occupancy		24 h Occupancy	
		U-Value W/m ² K	SHGC	U-Value W/m ² K	SHGC
(1)	(2)	(3)	(4)	(5)	(6)
i)	Mass walls	2.017	—	3.11	—
ii)	Curtain walls, other walls	2.72	—	4.11	—
iii)	Roofs	5.46	—	5.86	—
iv)	North windows	-3.10	29.66	-11.95	62.14
v)	Non-north windows	-2.98	34.86	-11.62	68.45
vi)	Skylights	-96.21	298.82	-294.12	876.70

Table 18 Envelope Performance Factor Coefficient — Cold Climate
(Clause C-1)

SI No.	Building Component	Daytime Occupancy		24 h Occupancy	
		U-Value W/m ² K	SHGC	U-Value W/m ² K	SHGC
(1)	(2)	(3)	(4)	(5)	(6)
i)	Mass walls	5.19	—	5.19	—
ii)	Curtain walls, other walls	6.76	—	6.76	—
iii)	Roofs	5.69	—	5.67	—
iv)	North windows	1.55	9.13	1.55	9.13
v)	Non-north windows	-1.13	16.32	-1.13	16.32
vi)	Skylights	-93.44	283.18	-93.44	283.18

ANNEX D

[Clause 8.2(c)]

WHOLE BUILDING ANALYSIS METHOD FOR ENVELOPE OPTIMIZATION

D-1 A building complies with the whole building performance requirement when the estimated annual energy use of the proposed design is less than the standard design, even though it may not comply with the specific requirements of the prescriptive requirements given in Annex B. Annual energy use for the purposes of the whole building performance method shall be calculated, in kilowatt-hour (kWh), of electricity use per year.

D-2 SIMULATION GENERAL REQUIREMENTS

A simulation program may be used for the analysis of energy consumption in buildings to model the following:

- a) Energy flows on an hourly basis for all 8 760 h in the year;
- b) Hourly variations in occupancy, lighting power, miscellaneous equipment power, thermostat set points and HVAC system operation, defined separately for each day of the week and holidays;
- c) Thermal mass effects;
- d) Ten or more thermal zones;
- e) Part-load and temperature dependent performance of heating and cooling equipment;
- f) Airside and waterside economizers with integrated control; and
- g) All the standard design characteristics specified in this chapter.

The simulation program shall use hourly values of climatic data, such as temperature and humidity from representative climatic data, for the city in which the proposed building is to be located. For cities or urban regions with several climatic data entries, and for locations where weather data are not available, the designer shall select available weather data that best represent the climate at the construction site.

The proposed design and standard design shall be calculated using the following:

- 1) Same simulation program;
- 2) Same weather data; and

- 3) Same building operation assumptions (thermostat set points, schedules, internal gains, occupant loads, etc).

D-3 CALCULATING THE ENERGY CONSUMPTION OF THE PROPOSED DESIGN AND THE STANDARD DESIGN

The simulation model for calculating the proposed design and the standard design shall be developed in accordance with the requirements in Table 19. The HVAC system type and related performance parameters for the standard design shall be determined from Table 20 and the following rules:

- a) All HVAC and service water heating equipment in the standard design shall be modelled at the minimum efficiency levels, both part load and full load.
- b) Where efficiency ratings, such as energy efficiency ratio (EER) and coefficient of performance (COP), include fan energy, the descriptor shall be broken down into its components so that supply fan energy can be modelled separately.
- c) Minimum outdoor air ventilation rates shall be the same for both the standard design and the proposed design.
- d) The equipment capacities for the standard design shall be sized proportionally to the capacities in the proposed design based on sizing runs; that is, the ratio between the capacities used in the annual simulations and the capacities determined by the sizing runs shall be the same for both the proposed design and standard design. Unmet load hours for the proposed design shall not differ from unmet load hours for the standard design by more than 50 h.

Components and parameters not listed in Table 20 or otherwise specifically addressed in this Part of the Code shall be identical to those in the proposed design. Where there are specific requirements in this Part of the Code the component efficiency in the standard design shall be adjusted to the lowest efficiency level allowed by the requirement for that component type.

Table 19 Modelling Requirements for Calculating Proposed and Standard Design
(Clause D-3)

Sl No.	Case	Proposed Building	Standard Design
(1)	(2)	(3)	(4)
i)	Design model	<p>a) The simulation model of the proposed design shall be consistent with the design documents, including proper accounting of fenestration and opaque envelope types and area; interior lighting power and controls; HVAC system types, sizes, and controls; and service water heating systems and controls</p> <p>b) When the whole building performance method is applied to buildings in which energy-related features have not yet been designed (for example, a lighting system), those yet-to-be-designed features shall be described in the proposed design so that they minimally comply with applicable mandatory and prescriptive requirements</p>	<p>The standard design shall be developed by modifying the proposed design as described in this table. Except as specifically instructed in this table, all building systems and equipment shall be modelled identically in the standard design and proposed design</p>
ii)	Space use classification	The building type or space type classifications shall be chosen in accordance with this code. More than one building type category may be used in a building if it is a mixed-use facility	Same as proposed design
iii)	Schedules	The schedules shall be typical of the proposed building type as determined by the designer	Same as proposed design
iv)	Building envelope	<p>All components of the building envelope in the proposed design shall be modelled as shown on architectural drawings or as installed for existing building envelopes</p> <p><i>Exceptions:</i> The following building elements are permitted to differ from architectural drawings:</p> <p>a) Any envelope assembly that covers less than 5 percent of the total area of that assembly type (for example, exterior walls) need not be separately described. If not separately described, the area of an envelope assembly shall be added to the area of the adjacent assembly of that same type</p> <p>b) Exterior surfaces whose azimuth orientation and tilt differ by no more than 45° and are otherwise the same may be described as either a single surface or by using multipliers</p> <p>c) For exterior roofs other than roofs with ventilated attics, the reflectance and emittance of the roof surface shall be modelled</p> <p>d) Manually operated fenestration shading devices such as blinds or shades shall not be modelled. Permanent shading devices such as fins, overhangs, and light shelves shall be modelled</p>	<p>The standard design shall have identical conditioned floor area and identical exterior dimensions and orientations as the proposed design, except as noted in (a) to (d)</p> <p>a) <i>Orientation</i> — The baseline building performance shall be generated by simulating the building with its actual orientation and again after rotating the entire building 90°, 180°, 270°, then averaging the results. The building shall be modelled so that it does not shade itself</p> <p>b) Opaque assemblies such as roof, floors, doors, and walls shall be modelled as having the same heat capacity as the proposed design but with the minimum <i>U-value</i> required in B-1 and B-2</p> <p>c) <i>Fenestration</i> — Fenestration areas shall equal that in the proposed design or 40 percent of gross above grade wall area, whichever is smaller, and shall be distributed uniformly in horizontal bands across the four orientations. No shading projections are to be modelled; fenestration shall be assumed to be flush with the exterior wall or roof. Manually operated fenestration shading devices such as blinds or shades shall not be modelled. Fenestration <i>U-value</i> shall be the minimum required for the climate, and the solar heat gain coefficient shall be the maximum allowed for the climate and orientation</p> <p>d) <i>Roof albedo</i> — All roof surfaces shall be modelled with a reflectivity of 0.30</p>
v)	Lighting	<p>Lighting power in the proposed design shall be determined as follows:</p> <p>a) Where a complete lighting system exists, the actual lighting power shall be used in the model</p> <p>b) Where a lighting system has been designed, lighting power shall be determined</p> <p>c) Where no lighting exists or is specified, lighting power shall be determined for the appropriate building type</p> <p>d) Lighting system power shall include all lighting system components shown or provided for on plans (including lamps, ballasts, task fixtures, and furniture-mounted fixtures)</p>	<p>Lighting power in the standard design shall be determined using the same categorization procedure (building area or space function) and categories as the proposed design, with the lighting power to be set equal to the maximum allowed for the corresponding method and category in either Table 20 or Table 21. Power for fixtures not included in the lighting power density calculation shall be modelled identically in the proposed design and standard design</p>

Table 19 — (Concluded)

(1)	(2)	(3)	(4)
vi)	HVAC system	<p>The HVAC system type and all related performance parameters, such as equipment capacities and efficiencies, in the proposed design shall be determined as follows:</p> <ol style="list-style-type: none"> Where a complete HVAC system exists, the model shall reflect the actual system type using actual component capacities and efficiencies Where an HVAC system has been designed, the HVAC model shall be consistent with design documents. Mechanical equipment efficiencies shall be adjusted from actual design conditions to the standard rating conditions, if required by the simulation model Where no heating system exists or no heating system has been specified, the heating system shall be modelled as electric resistance. The system characteristics shall be identical to the system modelled in the standard design Where no cooling system exists or no cooling system has been specified, the cooling system shall be modelled as an air-cooled single zone system, one unit per thermal block. The system characteristics shall be identical to the system modelled in the standard design 	<p>The HVAC system type and related performance parameters for the standard design shall be determined from Table 22. Equipment performance shall meet the requirements of this Code and the relevant Indian Standards</p>
vii)	Service hot water	<p>The service hot water system type and all related performance parameters, such as equipment capacities and efficiencies, in the proposed design shall be determined as follows:</p> <ol style="list-style-type: none"> Where a complete service hot water system exists, the model shall reflect the actual system type using actual component capacities and efficiencies Where a service hot water system has been designed, the service hot water model shall be consistent with design documents Where no service hot water system exists or is specified, no service hot water heating shall be modelled 	<p>The water heating system shall be of the same type of the proposed design</p> <p>For residential facilities, hotels and hospitals the standard design shall have a solar system capable of meeting 20 percent of the design load</p> <p>Systems shall meet the prescribed efficiency requirements of equipment, pipe insulation and incorporate heat traps in accordance with the relevant applicable Indian Standards</p>
viii)	Miscellaneous load	<p>Receptacle, motor, and process loads shall be modelled and estimated based on the building type or space type category</p> <p>These loads shall be included in simulations of the building and shall be included when calculating the standard design and proposed design. All end-use load components within and associated with the building shall be modelled, unless specifically excluded, but not limited to, exhaust fans, parking garage ventilation fans, exterior building lighting, swimming pool heaters and pumps, elevators and escalators, refrigeration equipment, and cooking equipment</p>	<p>Receptacle, motor and process loads shall be modelled the same as the proposed design. The water heating system shall be of the same type of the proposed design</p>
ix)	Modelling limitations to the simulation program	<p>If the simulation program cannot model a component or system included in the proposed design, one of the following methods shall be used with the approval of the authority having jurisdiction:</p> <ol style="list-style-type: none"> Ignore the component if the energy impact on the trade-offs being considered is not significant Model the component substituting a thermodynamically similar component model Model the HVAC system components or systems using the standard design's HVAC system in accordance with SI No. (vi) <p>Whichever method is selected, the component shall be modelled identically for both the proposed design and standard design models</p>	<p>Same as the proposed case</p>
<p>NOTE — The energy simulation results shall be reported for the proposed building and standard design and the percentage savings in annual energy consumption achieved each for interior lighting, exterior lighting, HVAC, domestic hot water and other/miscellaneous equipment consuming substantial energy. The total energy savings for all equipment, that is, total building load shall also be reported.</p>			

Table 20 Interior Lighting Power — Building Area Method
(Table 19)

SI No.	Building Area Type	LPD W/m ²
(1)	(2)	(3)
i)	Automotive facility	9.7
ii)	Convention center	12.9
iii)	Court house	12.9
iv)	Dining: bar/lounge/leisure	14.0
v)	Dining: cafeteria/fast food	15.1
vi)	Dining: family	17.2
vii)	Dormitory	10.8
viii)	Exercise center	10.8
ix)	Gymnasium	11.8
x)	Healthcare clinic	10.8
xi)	Hospital/health care	12.9
xii)	Hotel	10.8
xiii)	Library	14.0
xiv)	Manufacturing facility	14.0
xv)	Motel	10.8
xvi)	Motion picture theater	12.9
xvii)	Multifamily	7.5
xviii)	Museum	11.8
xix)	Office	10.8
xx)	Parking garage	3.2
xxi)	Penitentiary	10.8
xxii)	Performing arts theater	17.2
xxiii)	Police/fire station	10.8
xxiv)	Post office	11.8
xxv)	Religious building	14.0
xxvi)	Retail	16.1
xxvii)	School/university	12.9
xxviii)	Sports arena	11.8
xxix)	Town hall	11.8
xxx)	Transportation	10.8
xxxi)	Warehouse	8.6
xxxii)	Workshop	15.1

NOTE — In cases where both a general building area type and a specific building area type are listed, the specific building area type shall apply.

Table 21 Interior Lighting Power — Space Function Method
(Table 19)

SI No.	Building Area Type	LPD (W/m ²)
(1)	(2)	(3)
i)	Office-enclosed	11.8
ii)	Office-open plan	11.8
iii)	Conference/meeting/multipurpose	14.0
iv)	Classroom/lecture/training	15.1
v)	Lobby	14.0
vi)	For hotel	11.8
vii)	For performing arts theater	35.5
viii)	For motion picture theater	11.8
ix)	Audience/seating area	9.7
x)	For gymnasium	4.3
xi)	For exercise center	3.2
xii)	For convention center	7.5
xiii)	For religious buildings	18.3
xiv)	For sports arena	4.3
xv)	For performing arts theatre	28.0
xvi)	For motion picture theatre	12.9

Table 21 — (Continued)

(1)	(2)	(3)
xvii)	For transportation	5.4
xviii)	Atrium-first three floors	6.5
xix)	Atrium-each additional floor	2.2
xx)	Lounge/recreation	12.9
xxi)	For hospital	8.6
xxii)	Dining area	9.7
xxiii)	For hotel	14.0
xxiv)	For motel	12.9
xxv)	For bar lounge/leisure dining	15.1
xxvi)	For family dining	22.6
xxvii)	Food preparation	12.9
xxviii)	Laboratory	15.1
xxix)	Restrooms	9.7
xxx)	Dressing/locker/fitting room	6.5
xxxi)	Corridor/transition	5.4
xxxii)	For hospital	10.8
xxxiii)	For manufacturing facility	5.4
xxxiv)	Stairs-active	6.5
xxxv)	Active storage	8.6
xxxvi)	For hospital	9.7
xxxvii)	Inactive storage	3.2
xxxviii)	For museum	8.6
xxxix)	Electrical/mechanical	16.1
xl)	Workshop	20.5
xli)	Sleeping quarters	3.2
xl ii)	Convention centre — exhibit space	14.0
xl iii)	Library	
	a) Card file and cataloguing	11.8
	b) Stacks	18.3
	c) Reading area	12.9
xl iv)	Hospital	
	a) Emergency	29.1
	b) Recovery	8.6
	c) Nurse station	10.8
	d) Exam treatment	16.1
	e) Pharmacy	12.9
	f) Patient room	7.5
	g) Operating room	23.7
	h) Nursery	6.5
	j) Medical supply	15.1
	k) Physical therapy	9.7
	m) Radiology	4.3
	n) Laundry — washing	6.5
xl v)	Automotive — service repair	7.5
xl vi)	Manufacturing	
	a) Low bay (<8 m ceiling)	12.9
	b) High bay (>8 m ceiling)	18.3
	c) Detailed manufacturing	22.6
	d) Equipment room	12.9
	e) Control room	5.4
xl vii)	Hotel/motel guest rooms	11.8
xl viii)	Dormitory — living quarters	11.8
xl ix)	Museum	
	a) General exhibition	10.8
	b) Restoration	18.3
	c) Bank office — banking activity area	16.1
l)	Religions buildings	
	a) Worship-pulpit, choir	25.8
	b) Fellowship hall	9.7
li)	Retail	
	a) Sales area	18.3
	b) Mall concourse	18.3
li i)	Sports arena	
	a) Ring sports area	29.1
	b) Court sports area	24.8
	c) Indoor field area	15.1

Table 21 — (Continued)

(1)	(2)	(3)
liii)	Warehouse	
	a) Fine material storage	15.1
	b) Medium/bulky material storage	9.7
	c) Parking garage — garage area	2.2

Table 21 — (Concluded)

(1)	(2)	(3)
liv)	Transportation	
	a) Airport — concourse	6.5
	b) Air/train/bus — baggage area	10.8
	c) Terminal — ticket counter	16.1

Table 22 HVAC Systems Map
(Clause D-3)

Sl No.	Parameter	Residential More than 3 Storeys	Non-residential		
			Less than 3 floors or less than 7 500 m ²	4 or 5 floors or less than 7 500 m ² or 5 floors or less and 7 500 – 15 000 m ²	More than 5 floors or more than 15 000 m ²
(1)	(2)	(3)	(4)	(5)	(6)
i)	System Type	Packaged terminal air conditioner	Packaged rooftop air conditioner	Central cooling plant with constant volume AHU for each zone	Central cooling plant with constant volume AHU for each zone
ii)	Fan control	Constant volume	Constant volume	Constant volume air handler for each zone	Variable volume air handler
iii)	Cooling type	Direct expansion	Direct expansion	Chilled water	Chilled water
iv)	Heating type	Electric resistance	Electric resistance	Electric resistance	Electric resistance

NOTE — If the proposed building has an air cooled chiller/system then the budget building shall have Air cooled chiller otherwise the budget case shall have water cooled centrifugal chillers.

LIST OF STANDARDS

The following list records those standards which are acceptable as ‘good practice’ and ‘accepted standards’ in the fulfilment of the requirements of the Code. The standards listed may be used by the Authority for conformance with the requirements of the referred clauses in the Code.

In the following list, the number appearing in the first column within parantheses indicates the number of the reference in this Part.

	<i>IS No.</i>	<i>Title</i>
	457 : 1957	Code of practice for general construction of plain and reinforced concrete for dams and other massive structures
	458 : 2003	Specification for precast concrete pipes (with and without reinforcement) (<i>fourth revision</i>)
	459 : 1992	Specification for unreinforced corrugated and semi-corrugated asbestos cement sheets (<i>third revision</i>)
(1)	15792 : 2008	Guidelines for artificial recharge to groundwater
	15797 : 2008	Guidelines for roof top rainwater harvesting
(2)	3792 : 1978	Guide for heat insulation of non-industrial buildings (<i>first revision</i>)
(3)	456 : 2000	Code of practice for plain and reinforced concrete (<i>fourth revision</i>)
(4)	4926 : 2003	Code of practice for ready-mixed concrete (<i>second revision</i>)
(5)	455 : 2015	Specification for Portland Slag cement (<i>fifth revision</i>)
	456 : 2000	Code of practice for plain and reinforced concrete (<i>fourth revision</i>)
	1332 : 1986	Specification for precast reinforced concrete steel lighting poles (<i>first revision</i>)
	1343 : 2012	Code of practice for prestressed concrete (<i>second revision</i>)
	1489	Specification for Portland-pozzolana cement:
	(Part 1) : 2015	Fly ash based (<i>fourth revision</i>)
	(Part 2) : 2015	Calcined clay based (<i>fourth revision</i>)
	1592 : 2003	Specification for asbestos cement pressure pipes and joints (<i>fourth revision</i>)
	1626	Specification for asbestos cement

<i>IS No.</i>	<i>Title</i>	<i>IS No.</i>	<i>Title</i>
	building pipes and pipe fittings, gutters and gutter fittings and roofing fittings:		concrete (<i>second revision</i>)
(Part 1) : 1994	Pipe and pipe fittings (<i>second revision</i>)	5817 : 1992	Code of practice for preparation and use of lime pozzolana mixture concrete in buildings and roads (<i>first revision</i>)
(Part 2) : 1994	Gutters and gutter fittings (<i>second revision</i>)	5820 : 1970	Specification for precast concrete cable cover
(Part 3) : 1994	Roofing accessories (<i>second revision</i>)	6041 : 1985	Code of practice for construction of autoclaved cellular concrete block masonry (<i>first revision</i>)
1727 : 1967	Methods of test for pozzolanic materials (<i>first revision</i>)	6042 : 1969	Code of practice for construction of lightweight concrete block masonry
2096 : 1992	Specification for asbestos cement flat sheets (<i>first revision</i>)	6066 : 1994	Recommendations for pressure grouting of rock foundations in river valley projects (<i>second revision</i>)
2098 : 1997	Specification for asbestos cement building boards (<i>first revision</i>)	6072 : 1971	Specification for autoclaved reinforced cellular concrete wall slabs
2117 : 1991	Guide for manufacture of hand-made common burnt clay building bricks (<i>third revision</i>)	6073 : 2006	Specification for autoclaved reinforced cellular concrete floor and roof slabs (<i>first revision</i>)
2185	Specification for concrete masonry units:	6908 : 1991	Specification for asbestos cement pipes and fittings for sewerage and drainage (<i>first revision</i>)
(Part 1) : 2005	Hollow and solid concrete blocks (<i>third revision</i>)	8229 : 1986	Specification for oil well cement (<i>first revision</i>)
(Part 2) : 1983	Hollow and solid light-weight concrete blocks (<i>first revision</i>)	9142 : 1979	Specification for artificial lightweight aggregates for concrete masonry units
(Part 3) : 1984	Autoclaved cellular aerated, concrete blocks (<i>first revision</i>)	9375 : 1979	Specification for precast reinforced concrete plant guards
(Part 4) : 2008	Preformed foam cellular concrete blocks	9627 : 1980	Specification for asbestos cement pressure pipes (light duty)
2541 : 1991	Code of practice for preparation and use of lime concrete (<i>second revision</i>)	9872 : 1981	Specification for precast concrete septic tanks
3115 : 1992	Specification for lime based blocks (<i>second revision</i>)	9893 : 1981	Specification for precast concrete lintels and sills
3370	Code of practice for concrete structures for storage of liquids:	10049 : 1981	Code of practice for manufacture of lime based blocks
(Part 1) : 2009	General requirements (<i>first revision</i>)	10262 : 2009	Guidelines for concrete mix proportioning (<i>first revision</i>)
(Part 2) : 2009	Reinforced concrete structures (<i>first revision</i>)	10359 : 1982	Code of practice for manufacture and use of lime-pozzolana concrete blocks for paving
3466 : 1988	Specification for masonry cement (<i>second revision</i>)	10360 : 1982	Specification for lime-pozzolana concrete blocks for paving
3812	Specification for pulverized fuel ash:	10772 : 1983	Specification for quick setting lime-pozzolana mixture
(Part 1) : 2013	For use as Pozzolana in cement, cement mortar and concrete (<i>third revision</i>)	11293	Guidelines for design of grout curtains:
(Part 2) : 2013	For use as admixture in cement mortar and concrete (<i>third revision</i>)	(Part 1) : 1985	Earth and rockfill dams
4098 : 1983	Specification for lime-pozzolana mixture (<i>first revision</i>)	(Part 2) : 1993	Masonry and concrete dams
4139 : 1989	Specification for calcium silicate bricks (<i>second revision</i>)		
4926 : 2003	Code of practice for ready-mixed		

<i>IS No.</i>	<i>Title</i>	<i>IS No.</i>	<i>Title</i>
11650 : 1991	Guide for manufacture of common burnt clay building bricks by semi-mechanized process (<i>first revision</i>)	(8) 2185	Specification for concrete masonry units:
12089 : 1987	Specification for granulated slag for manufacture of Portland slag cement	(Part 1) : 2005	Hollow and solid concrete blocks (<i>third revision</i>)
12440 : 1988	Specification for precast concrete stone masonry blocks	(Part 2) : 1983	Hollow and solid lightweight concrete blocks (<i>first revision</i>)
12592 : 2002	Specification for precast concrete manhole cover and frame (<i>first revision</i>)	(Part 3) : 1984	Autoclaved cellular (aerated) concrete blocks (<i>first revision</i>)
12894 : 2002	Specification for pulverized fuel ash lime bricks (<i>first revision</i>)	(Part 4) : 2008	Preformed foam cellular concrete blocks
13000 : 1990	Specification for silica-asbestos cement flat sheets	12440 : 1988	Specification for precast concrete stone masonry blocks
13008 : 1990	Specification for shallow corrugated asbestos cement sheets	(9) 2572 : 2005	Code of Practice for construction of hollow concrete block masonry (<i>first revision</i>)
13757 : 1993	Specification for burnt clay fly ash building bricks	6041 : 1985	Code of Practice for construction of autoclaved cellular concrete block masonry (<i>first revision</i>)
14862 : 2000	Specification for fibre cement flat sheets	6042 : 1969	Code of Practice for construction of lightweight concrete block masonry
14871 : 2000	Specification for products in fibre reinforced cement — Long corrugated or asymmetrical section sheet and fittings for roofing and cladding	(10) 1725 : 2013	Specification for stabilized soil blocks used in general building construction (<i>second revision</i>)
15388 : 2003	Specification for silica fume	(11) 401 : 2001	Code of practice for preservation of timber (<i>fourth revision</i>)
15648 : 2006	Specification for pulverized fuel ash for lime pozzolana mixture application	1141 : 1993	Code of practice for seasoning of timber (<i>second revision</i>)
15916 : 2011	Code of practice for building design and erection using prefabricated concrete	(12) 303 : 1989	Specification for plywood for general purposes (<i>third revision</i>)
15917 : 2010	Code of practice for building design and erection using mixed/composite construction	710 : 2010	Specification for marine plywood (<i>second revision</i>)
(6) 2686 : 1977	Specification for cinder as fine aggregates for use in lime concrete (<i>first revision</i>)	1328 : 1996	Specification for veneered decorative plywood (<i>third revision</i>)
3068 : 1986	Specification for broken brick (burnt clay) coarse aggregates for use in lime concrete (<i>second revision</i>)	1658 : 2006	Specification for fibre hardboards (<i>third revision</i>)
3182 : 1986	Specification for broken brick (burnt clay) fine aggregates for use in lime mortar (<i>second revision</i>)	1659 : 2004	Specification for block boards (<i>fourth revision</i>)
9142 : 1979	Specification for artificial lightweight aggregates for concrete masonry units	3087 : 2005	Specification for wood particle boards (medium density) for general purposes (<i>second revision</i>)
(7) 9142 : 1979	Specification for artificial lightweight aggregates for concrete masonry units	3097 : 2006	Specification for veneered particle boards (<i>second revision</i>)
		3129 : 1985	Specification for low density particle board (<i>first revision</i>)
		3308 : 1981	Specification for wood wool building slabs (<i>first revision</i>)
		4990 : 2011	Specification for plywood for concrete shuttering work (<i>third revision</i>)
		5509 : 2000	Specification for fire retardant plywood (<i>second revision</i>)
		12406 : 2003	Specification for medium density

<i>IS No.</i>	<i>Title</i>	<i>IS No.</i>	<i>Title</i>
	fibreboards for general purposes (<i>first revision</i>)		of cement and cement-lime plaster finish (<i>first revision</i>)
12823 : 2015	Specification for wood products — Prelaminated particle boards (<i>first revision</i>)	(19) 2547	Specification for gypsum building plaster:
13958 : 1994	Specification for bamboo mat board for general purposes	(Part 1) : 1976	Excluding premixed lightweight plaster (<i>first revision</i>)
14587 : 1998	Specification for prelaminated medium density fibre board	(Part 2) : 1976	Premixed lightweight plaster (<i>first revision</i>)
14588 : 1999	Specification for bamboo mat veneer composite for general purposes	12679 : 1989	Specification for by-product gypsum for use in plaster, blocks and boards
14616 : 1999	Specification for laminated veneer lumber	(20) 14862 : 2000	Specification for fibre cement flat sheets
14842 : 2000	Specification for coir veneer board for general purposes	14871 : 2000	Specification for products in fibre reinforced cement long corrugated or asymmetrical section sheets and fittings for roofing and cladding
15380 : 2003	Specification for moulded raised high density fibre (HDF) panel doors	(21) 2095	Specification for gypsum plaster boards:
15476 : 2004	Specification for bamboo and corrugated sheets	(Part 1) : 2011	Plain gypsum plaster boards (<i>third revision</i>)
15491 : 2004	Specification for medium density coirboards for general purposes	(Part 2) : 2001	Coated/laminated gypsum plaster boards (<i>second revision</i>)
15877 : 2010	Specification for coir faced block boards	(Part 3) : 1996	Reinforced gypsum plaster boards (<i>second revision</i>)
15878 : 2010	Specification for coir hardboard for general purposes	8272 : 1984	Specification for gypsum plaster for use in the manufacture of fibrous plasterboards (<i>first revision</i>)
(13) 2250 : 1981	Code of practice for preparation and use of masonry mortars (<i>first revision</i>)	(22) 4021 : 1995	Specification for timber door, window and ventilator frames (<i>third revision</i>)
4443 : 1980	Code of practice for use of resin type chemical resistant mortars (<i>first revision</i>)	(23) 6523 : 1983	Specification for precast reinforced concrete door and window frames (<i>first revision</i>)
4832	Specification for chemical resistant mortars:	(24) 8183 : 1993	Specification for bonded mineral wool (<i>first revision</i>)
(Part 1) : 1969	Silicate type	(25) 3677 : 1985	Specification for unbonded rock and slag wool for thermal insulation (<i>second revision</i>)
(Part 2) : 1969	Resin type	(26) 2115 : 1980	Code of practice for flat roof finish: Mud <i>phuska</i> (<i>second revision</i>)
(Part 3) : 1969	Sulphur type	(27) 4082 : 1996	Recommendations on stacking and storage of construction materials and components at site (<i>second revision</i>)
(14) 13077 : 1991	Guide for preparation and use of mud mortar in masonry	7969 : 1975	Safety code for handling and storage of building materials
(15) 653 : 1992	Specification for linoleum sheets and tiles (<i>third revision</i>)	(28) 10500 : 2012	Drinking water (<i>second revision</i>)
1198 : 1982	Code of practice for laying, fixing and maintenance of linoleum floor (<i>first revision</i>)	11624 : 1986	Guidelines for the quality of irrigation water
(16) 1237 : 2012	Specification for cement concrete flooring tiles (<i>second revision</i>)	8188 : 1999	Treatment of Water for Cooling Towers — Code of Practice
1443 : 1972	Code of practice for laying and finishing of cement concrete flooring tiles (<i>first revision</i>)		
2114 : 1984	Code of practice for laying <i>in-situ</i> terrazzo floor finish (<i>first revision</i>)		
(17) 15622 : 2006	Specification for pressed ceramic tiles		
(18) 1661 : 1972	Code of practice for application		

<i>IS No.</i>	<i>Title</i>	<i>IS No.</i>	<i>Title</i>
201 : 1992	Quality tolerances for water for textile industry(<i>second revision</i>)		high pressure boilers
2724 : 1964	Quality tolerances for water for pulp and paper	13891 : 1994	Quality tolerances for freshwater for fish culture
2725 : 1964	Quality tolerances for water for rayon- manufacturing industry	3957 : 1966	Quality tolerances for water for ice manufacture
3328 : 1993	Quality tolerances for water for swimming pools (<i>first revision</i>)	(29) 15883 (Part 1) : 2009	Guidelines for construction project management: Part 1 General
4221 : 1967	Quality tolerances for water for tanning industry	(30) 456 : 2000	Code of practice for plain and reinforced concrete (<i>fourth revision</i>)
4251 : 1967	Quality tolerances for water for processed food industry	1343 : 2012	Code of practice for prestressed concrete (<i>second revision</i>)
4700 : 1968	Quality tolerances for water for fermentation	(31) 4130 : 1991	Safety code for demolition of buildings (<i>second revision</i>)
8914 : 1988	Quality tolerances for water for vitreous enamel industry (<i>first revision</i>)	(32) 6598 : 1972	Specification for cellular concrete for thermal insulation
10392 : 1982	Specification for feed water and boiler water for low and medium pressure boilers	(33) IS/ISO 817	Designation and safety classification of refrigerants (<i>under preparation</i>)
10496 : 1983	Specification for feed water, boiler water and condensate for	(34) 12615 : 2011	Energy efficient induction motors — Three phase squirrel cage (<i>second revision</i>)

NATIONAL BUILDING CODE OF INDIA

PART 12 ASSET AND FACILITY MANAGEMENT

BUREAU OF INDIAN STANDARDS

CONTENTS

FOREWORD	... 3
1 SCOPE	... 5
2 TERMINOLOGY	... 5
3 GENERAL ASPECTS OF ASSET/FACILITY MANAGEMENT	... 9
4 ORGANIZATIONAL STRUCTURE OF AN ASSET AND FACILITY MANAGEMENT SYSTEM	... 12
5 METHODOLOGY	... 13
6 RESOURCES REQUIREMENT FOR ASSET/FACILITY MANAGEMENT	... 14
7 PROCUREMENT OF ASSET/FACILITY RELATED SERVICES	... 15
8 CLASSIFICATION OF ASSET/FACILITY MANAGEMENT	... 17
9 BUILDING MAINTENANCE — METHODS AND MANAGEMENT	... 17
10 BUILDING FABRIC MAINTENANCE	... 30
11 MAINTENANCE OF PLUMBING AND DRAINAGE SYSTEMS	... 31
12 MAINTENANCE OF HEATING, VENTILATION AND AIR CONDITIONING (HVAC) SYSTEMS	... 36
13 MAINTENANCE OF ELECTRICAL INSTALLATIONS	... 38
14 OPERATIONS AND MAINTENANCE OF LIFTS AND ESCALATORS	... 41
15 MAINTENANCE OF FIRE FIGHTING SYSTEMS	... 45
16 ROADS AND PATHWAYS MAINTENANCE AND UPKEEP	... 46
17 HEALTH AND SAFETY REQUIREMENTS	... 47
18 MAINTENANCE OF LANDSCAPING AND HORTICULTURE WORKS	... 49
19 HOUSE KEEPING	... 52
20 PEST AND RODENTS CONTROL	... 53
21 SECURITY SERVICES FOR BUILDING OCCUPANTS AND ASSETS/ FACILITIES	... 54
22 SOLID WASTE MANAGEMENT	... 61
23 BUILDING MANAGEMENT SYSTEMS (BMS)	... 63
24 INFORMATION MANAGEMENT	... 66
25 CHECK LISTS	... 71
ANNEX A COMMON CAUSES FOR MAINTENANCE PROBLEMS	... 72
ANNEX B FORMAT FOR INSPECTION REPORT	... 74
ANNEX C TYPICAL NORMS FOR EMPLOYMENT OF WORKMEN FOR DAY-TO-DAY MAINTENANCE OF BUILDINGS	... 81
ANNEX D METHODS OF OPERATIONAL CHECKS FOR STP	... 82
ANNEX E GUIDELINES FOR MAINTENANCE OF ELECTRICAL EQUIPMENT	... 87
ANNEX F FORMAT FOR PREVENTIVE MAINTENANCE PROFILE OF LIFTS	... 89
ANNEX G TYPICAL CHECKLISTS FOR MAINTENANCE OF LIFTS AND ESCALATORS	... 91
ANNEX H TYPICAL CHECK LIST FOR LANDSCAPE AREAS	... 95
ANNEX J TYPICAL TEMPLATE FOR HOUSEKEEPING OF HOTELS	... 95
LIST OF STANDARDS	... 97

FOREWORD

There has been significant growth in the requirement of building maintenance in view of an increased output of the construction industry in terms of buildings and built environment. This has been primarily due to large scale new construction taking place all across the country. While there is a need for proper maintenance of the existing building assets, there is a growing awareness of the need to manage the condition of the nation's building stock more efficiently. Paralleling these developments has been the increased application of new technology, permitting more efficient use of data and resources. Notwithstanding this, it is still the case that much maintenance activities take place in a context that do not create a fully integrated approach to managing asset/facility performance and, thus, the full potential of many assets/facilities is never wholly realized. The likely adverse impact on safety and business continuity due to lack of a well planned maintenance strategy is also not fully appreciated as yet.

Poor detailed design affects building performance, and hence impacts maintenance cost and consequent effect is well known. There is need to look into this aspect and explore design-maintenance relationship. Many of the problems encountered in buildings stem from the development phase, where a failure to establish user requirements in sufficient detail results in the poor performance of the completed building. At the hand-over stage also there may be serious shortcomings, and more careful consideration need to be given to providing the client with a proper building model to facilitate the effective management of the property. None of these crucial developments can take place without a major shift in client attitudes, and professions working with the built environment.

Considering all the above, the National Building Code Sectional Committee decided to incorporate this new Part to NBC, namely, Part 12, to give a comprehensive approach to asset and facility management for adoption by all concerned.

This Part 12 of the Code covers provisions relating to management of building assets and associated services and deals with issues relating to maintenance of all types of facilities and fixed assets such as buildings and building services. Besides these provisions, critical activities and critical assets which need to be focused upon by facility managers have also been identified. The responsibilities of occupants for maintenance of facilities, such as, structures, equipment and exterior property have also been covered.

While outlining a process approach to maintenance management at the strategic and tactical level with links to operational activities, an attempt has been made to make the owners and occupants aware of the importance of initiating timely action to formulate strategies and policies for maintenance management. Measures that will help organizations and individuals to assist those responsible for ensuring that asset and facility continue to perform as intended, retaining their asset value at minimum cost, have been outlined. While focusing on the activities required to maintain an asset or a complete facility, it is imperative that capabilities of the Facility Managers are improved in general so that money spent on maintaining the assets yield value.

Following Indian Standards have been utilized while formulating this Part 12:

IS 15183	Guidelines for maintenance management of buildings:
(Part 1) : 2002	General
(Part 2) : 2002	Finance
(Part 3) : 2002	Labour

Considerable assistance has also been drawn from following International Standards while formulating this Part:

ISO 55000 : 2014	Asset/Facility management — Overview, principles and terminology
ISO 55001 : 2014	Asset/Facility management — Management systems — Requirements
ISO 55002 : 2014	Asset/Facility management — Management systems — Guidelines for the application of ISO 55001
BS 8210 : 2012	Guide to facilities maintenance management

- BS 8536 : 2010 Asset/Facility management briefing code of practice
BS 8572 : 2011 Guide to procurement of facility-related services
BS 8587 : 2012 Guide to facility information management
BSI PAS 55 : 2008 Publicly available specification for the optimal management of physical assets

Reference has also been made to following publications:

Maintenance Manual 2012, Central Public Works Department, Govt of India.

Solid Waste Management Rules, 2016, Ministry of Environment, Forest and Climate Change, Govt. of India

Hazardous and Other Wastes (Management and Transboundary Movement) Rules, 2016, Ministry of Environment, Forest and Climate Change, Govt. of India

All standards, whether given herein above or cross-referred to in the main text of this Part, are subject to revision. The parties to agreement based on this Part are encouraged to investigate the possibility of applying the most recent editions of the standards.

For the purpose of deciding whether a particular requirement of this Part is complied with, the final value, observed or calculated, expressing the result of a test or analysis, shall be rounded off in accordance with IS 2 : 1960 'Rules for rounding off numerical values (*revised*)'. The number of significant places retained in the rounded off value should be the same as that of the specified value in this Part of the Code.

NATIONAL BUILDING CODE OF INDIA

PART 12 ASSET AND FACILITY MANAGEMENT

1 SCOPE

1.1 This Part 12 covers provisions relating to management of building assets and associated facilities and includes various aspects relating to maintenance of all types of facilities and fixed assets, such as, buildings and building services.

1.2 This Part does not cover assets other than physical assets.

1.3 Whereas all asset and facility management services in permanent or temporary buildings, including mechanical, electrical and plumbing services relating to buildings, maintenance of landscaped areas, etc, are covered in this Part, the maintenance of bulk services required for towns and cities are not covered in this Part. This Part, however, covers all operations/efforts required to ensure that the asset/facility continues to meet the requirements which were set for it during design stage.

2 TERMINOLOGY

For the purpose of this Part, the following definitions shall apply.

2.1 Access — Approach, entry, internal circulation or exit, including in cases of emergency.

2.2 Ageing — Getting old, specifically beyond the design life of the asset.

2.3 As-built Information — Expression of the design, its working detail, construction works and/or installations, functions, operations and maintenance needs of a facility in a form suitable for use in managing that facility.

2.4 Asset — A useful or valuable thing or an item of property owned by a person or organization, regarded as having value and life of more than one year, available to meet debts, commitments, or legacies and performing predetermined functions to facilitate the users.

2.5 Asset Life — Period from asset creation to end of its functional life.

2.6 Asset Register — A central database of information about asset/facility in terms of their manufacturer, vendor, make, model, specifications, date of acquisition, initial cost, maintenance costs and requirements, additions/alterations over period, accumulated depreciation and written down value.

2.7 Asset Type — Grouping of assets having common characteristics that distinguish those assets as a group or class, for example, physical assets, information

assets, intangible assets, critical assets, enabling assets, linear assets, information and communications technology (ICT) assets and infrastructure assets.

2.8 Asset/Facility Management — Integration of processes within an organization to maintain and develop the agreed services which support and improve the effectiveness of its primary activities.

2.9 Benchmarking — Comparing performance, often between companies in similar sectors.

2.10 Biodegradable Waste — Any organic material that can be degraded by microorganisms into simpler stable compounds.

2.11 Briefing — Briefing is the process of communicating the objectives and needs of an owner, or prospective owner, of a facility to a designer in order to prepare a design for that facility. This process includes clarification and confirmation of the owner's intentions and documenting the consequent provisions for the facility to enable informed decision making primarily in design, but also in construction work and/or installation, testing and commissioning, handover and start-up of operations. A number of stages are envisaged for preparing and applying the brief during design and in later phases.

2.12 Buffer Zone — A zone of no development which shall be maintained around landfills, processing and disposal facilities of solid waste.

2.13 Building Fabric — Elements and components of a building other than furniture and services installations.

2.14 Building Information Model (BIM) — Shared digital representation of physical and functional characteristics of any built object (including buildings, bridges, roads, etc) which forms a reliable basis for decisions.

NOTE — A building information model may embody, for example, building geometry, spatial relationships, geographic information and the quantities and properties of building components.

2.15 Building Maintenance Work undertaken to maintain or restore the performance of the building fabric and its services to provide an efficient and acceptable operating environment to its users.

2.16 Building Management System (BMS) — Computer aided control systems, including hardware and software, to collect and monitor parameters and performance data of plant, equipment, systems and elements either at source or remotely and to enable corrective action to be initiated.

2.17 Building Manual — Guidance to assist in making the best use of the design features, services and systems of a building or other facility.

2.18 Business Continuity Management (BCM) — Holistic management process that identifies potential threats to an organization and the impacts to business operations that those threats, if realized, may cause, and which provides a framework for building organizational resilience with the capability for an effective response that safeguards the interests of its key stakeholders, reputation, brand and value creating activities.

2.19 Carbon Emissions — Polluting carbon substances released into the atmosphere.

2.20 Carbon Footprint — Totality of greenhouse gas (GHG) emissions caused directly and indirectly by an individual, organization, event or product.

2.21 Cleaning — Locating, identifying and properly disposing of undesirable substances from surfaces or material.

2.22 Cleaning Services — Services undertaken to ensure the cleanliness, maintenance and aesthetic upkeep of the building/property.

2.23 Competent Person — Person, suitably trained and qualified by knowledge and practical experience.

2.24 Computer Aided Facilities Management (CAFM) — Systems, applications and tools that automate functions needed to support the core business in its efficient and effective use of facilities.

2.25 Computer Aided Maintenance Management System (CMMS) — System specifically designed to enable planning, organizing, directing and controlling maintenance programmes and to collect and collate historical data on the performance of assets so that the most effective maintenance method is selected under actual performance and environmental conditions.

2.26 Condition Monitoring — Act of measuring and recording data from operating parameters, using either human senses or instrumentation, to verify plant and equipment condition and trends. It is also the act of assessing an asset to understand how it is likely to perform in future.

2.27 Confined Space — Space which may be inadequately ventilated for any reason and may result in a deficiency of oxygen, or a build-up of toxic gases, for example, closed tanks, sewers, ducts, closed and unventilated rooms, and tanks particularly where heavier than air gases or vapours may be present.

2.28 Corrective Maintenance — Maintenance carried out after fault recognition and intended to put an item into a state in which it can perform a required function.

2.29 Crime Prevention Through Environmental Design (CPTED) — A multi-disciplinary approach to deterring criminal behavior through environmental design. CPTED strategies rely upon the ability to influence offender decisions that precede criminal acts. CPTED principles of design affect elements of the built environment ranging from the small-scale (such as the strategic use of shrubbery and other vegetation) to the overarching, including building form of an entire urban neighbourhood and the amount of opportunity for ‘eyes on the street’.

2.30 Critical Activities — Activities which have to be performed in order to deliver the key products and services which enable an organization to meet its most important and time sensitive objectives.

2.31 Critical Asset — Asset having potential to significantly impact on the achievement of the organization’s objectives.

2.32 De-construction — A planned selective demolition in which salvage, re-use and recycling of the demolished structure is maximized.

2.33 Deliverable — Product or service as an outcome of a process.

2.34 Design Development — Transitional phase where the basis of the design progresses towards the production of detailed design information.

2.35 Design Life (DL) — Intended/expected service life by the designer or as stated by the designer to the client to support specification decisions.

2.36 Documented Information — Information required to be controlled and maintained by an organization and the medium on which it is contained.

2.37 Domestic Hazardous Waste — Waste contaminated with hazardous chemicals or infectious waste such as discarded paint drums, pesticide cans, CFL bulbs, tube lights, expired medicines, broken mercury thermometers, used batteries, used needles, gauge and syringes, etc, generated at the household level.

2.38 Dry Waste — Waste, other than food waste, inert and including recyclable waste, non-recyclable waste, combustible waste and sanitary waste.

2.39 Dump Sites — A land utilized by urban local body for unscientific disposal of solid waste without following the principles of sanitary land filling.

2.40 Durability — Ability of a building and its parts to perform its required function over a period of time and under the influence of agents.

2.41 Duress Alarms — Duress alarms are installed to protect personnel who may be placed in danger of

physical assault during interactions with other persons. Duress alarms are normally placed in locations where an employee may be alone with a potentially threatening person.

2.42 End-user — Recipient of facility-related services.

NOTE — Recipients include occupants and other users of a facility.

2.43 Estimated Service Life (ESL) — Service life that a building or parts of a building should be expected to have in a set of specific in use conditions, determined from the reference service life data after taking into account any differences from the reference in-use conditions.

2.44 Exterior Property — The open space on the premises under the control of owners or operators of such premises.

2.45 External Envelope — Roof and façade including openings.

2.46 Facilities Maintenance — Work needed to maintain the performance of the building structure, fabric and components, and engineering installations.

2.47 Facility — Tangible asset that supports/serves an organization.

2.48 Facility Asset Performance — Requirements in terms of measurable outcomes for meeting organizational goals.

2.49 Hazardous Waste — It shares the properties of a hazardous material (for example ignitability, corrosivity, reactivity, or toxicity), or other physical, chemical, or biological characteristics that may pose a potential risk to human health or the environment if improperly managed. Wastes may also be defined as ‘hazardous’ by local regulations or international conventions, based on the origin of the waste and its inclusion on hazardous waste lists, or based on its characteristics. Sludge from a waste treatment plant, water supply treatment.

2.50 House Keeping — The routine recurring work which is required to keep a structure in good condition so that it can be utilized at its original capacity and efficiency along with proper protection of capital investment, throughout its economic life.

2.51 Information Management — Processing and storage of information in a controlled manner.

2.52 Intrusion Detection Systems — An intrusion detection system (IDS) is a device or software application that monitors the activities for malicious activities or policy violations and produces reports to a management station. Intrusion detection and prevention systems (IDPS) are primarily focused on

identifying possible incidents, logging information about them, and reporting attempts.

2.53 Life Cycle — The stages of an asset from acquisition through commissioning and operation to disposal.

2.54 Maintenance — An intervention on an asset to improve its operation or ensure its continued good operation (It is also the combination of all technical and associated administrative actions during the service life to retain a building, or its parts, in a state in which it can perform its required functions.).

2.55 Maintenance Management — Process of ensuring that the most effective and efficient maintenance programme is formulated and delivered to ensure that assets/facilities continue to perform their intended function. The organization of maintenance has to be within an agreed policy. Maintenance can be seen as a form of ‘steady state’ activity.

2.56 Maintenance Manual — Technical instructions intended to preserve an asset/facility in, or, restore it to a state in which it can perform a required function.

2.57 Maintenance Plan — Structured and documented set of tasks that include the activities, procedures, resources and the time scale required to carry out maintenance.

2.58 Maintenance Policy — Scope and course of action taken to achieve an organization’s objectives.

2.59 Maintenance Programme — Arrangement of maintenance tasks in terms of their sequence, durations and resource requirements.

2.60 Maintenance Strategy — Statement of organizational approach to maintenance management.

2.61 Management System — Set of interrelated or interacting elements of an organization to establish policies and objectives and processes to achieve those objectives.

2.62 Mantrap — A small room with two doors. The first door is locked; a person is identified and authenticated. Once the person is authenticated and access is authorized, the first door opens and allows the person into the mantrap. The person has to be authenticated again in order to open the second door and access a critical area. The mantrap area can have a weight sensing floor as an additional control to prevent literal piggybacking.

2.63 Occupants — Users who spend a significant proportion of their time in or about a facility.

2.64 Operational Plan — Organization’s statement of actions intended to achieve a specific business goal(s).

2.65 Operational Strategy — Overall approach to managing production or use of a facility.

2.66 Perimeter Intrusion Detection and Assessment System (PIDAS) — A type of fencing that has sensors on the wire mesh and base of the fence. A passive cable vibration sensor sets off an alarm if an intrusion is detected.

2.67 Perimeter Security — Control and observation of areas of ingress and egress to a building and parking structure, including main lobby doors, rear plaza doors, truck docks, fire exits, and other points of access.

2.68 Physical Asset — A tangible, manmade object that has a specific function, normally within a broader system.

2.69 Planned Preventive Maintenance — Maintenance organized and carried out with forethought, control and the use of records to a plan based on the results of condition surveys.

2.70 Predicted Service Life — Service life predicted from performance recorded over time in accordance with standard laid down procedure.

2.71 Predictive Action — Action to monitor the condition of an asset and predict the need for preventive action or corrective action.

2.72 Preventive Maintenance — An intervention on an asset taken in advance of a failure to reduce the chances of failure.

2.73 Preventive Action — Action to eliminate the cause of a potential non-conformity or other undesirable potential situation (for asset/facility management).

2.74 Primary Collection — Collecting, lifting and removal of segregated solid waste from source of its generation including households, shops, offices and any other non-residential premises or from any collection points or any other location specified by the urban local body.

2.75 RASCI Chart — Responsible, accountable, supported, consulted and informed chart that is used to summarize the roles and functions performed in the procurement process and the activities within it.

2.76 Reliability Centered Maintenance (RCM) — An approach which targets intervention on assets based on the known historic performance of that or similar assets.

2.77 Repair, Renovate, Refurbish — An intervention which improves the performance and condition of an asset to upgrade or retain desired performance.

2.78 Residual Waste — Includes the waste and rejects from the solid waste processing facilities which are not

suitable for recycling or further processing.

2.79 Root Cause Analysis — A thorough assessment of all of the factors influencing the occurrence of a fault or failure.

2.80 Sanitary Land Filling — The final and safe disposal of residual solid waste and inert wastes on land in a facility designed with protective measures against pollution of ground water, surface water and fugitive air dust, wind-blown litter, bad odour, fire hazard, animal menace, bird menace, pests or rodents, greenhouse gas emissions, persistent organic pollutants slope instability and erosion.

2.81 Sanitary Waste — Wastes comprising of used diapers, sanitary towels or napkins, tampons, condoms, incontinence sheets and any other similar waste.

2.82 Scope Creep — Uncontrolled changes to the agreed scope of the facility related service being provided.

2.83 Secondary Collection — Collection of solid waste deposited at secondary waste storage depots or bins for onward transportation of the waste to the processing or disposal facility.

2.84 Secondary Storage — The temporary containment of solid waste at a public place in a covered bin or container in a manner so as to prevent littering, vectors, stray animals and odour.

2.85 Service Life — Period of time after installation during which a building or its parts meets or exceed the performance requirements.

2.86 Shutdown/Outage — A period, either planned or otherwise, during which asset interventions occur.

2.87 Stabilizing — The biological decomposition of biodegradable wastes to a stable state where it generates no leachate or offensive odours and is fit for application to farm land, soil erosion control and soil remediation.

2.88 Stakeholder — Individual, organization or group with an interest in an organization, facility or project. It also applies to the person or entity with an interest in or concern about a facility.

2.89 Surveillance — Surveillance is the monitoring of the behaviour, activities, or other changing information, usually of people for the purpose of influencing, managing, directing, or protecting them. This can include observation from a distance by means of electronic equipment (such as, CCTV cameras). Surveillance is used for intelligence gathering, the prevention of crime, the protection of a process, person, group or object, or for the investigation of crime. Surveillance is often a violation of privacy, and is opposed by various civil liberties groups and activists.

2.90 Surveillance Devices — Surveillance device can be defined as any instrument, apparatus or equipment used either alone, or in conjunction with other equipment, which is being used to conduct surveillance.

2.91 Whole Life Costing — An understanding of the full economic impact of owning an asset, covering all stages of its life cycle.

3 GENERAL ASPECTS OF ASSET/FACILITY MANAGEMENT

3.1 Asset and its Management

The physical assets represent only one of the five broad categories of asset types that have to be managed holistically in order to achieve the organizational strategic plan. The other categories are human assets, information assets, financial assets and intangible assets (reputation, morale, intellectual property, goodwill, etc). The scope of this Part is limited to maintenance of physical assets.

Asset management is the process by which an owner maximizes the value of a property or portfolio of properties from acquisition to disposition within the objectives defined by the owner.

Asset management utilizes strategic planning practices including investment analysis, operation analysis and the positioning of a property in the market place in accordance with market trends.

3.2 Facility and its Management

Facility is something that is built for a specific purpose and which is used by end users for predetermined purposes. Facilities management is the integration of processes within an organization to maintain and develop the agreed services which support and improve the effectiveness of its primary activities as well as enhances its ability to successfully control the building environment that houses people (employees, clients, visitors). Facilities management encompasses multi-disciplinary activities within the built environment and the management of their impact upon people and the workplace. It is also known as a profession that encompasses multiple disciplines to ensure functionality of the built environment by integrating people, place, process and technology.

3.3 Overview of Asset/Facility Management

Asset/Facility management is a multidisciplinary approach for designing, planning and managing in an integrated and coordinated way all non-core support services necessary for an effective and efficient execution of the organization's core activities. It involves systematic and coordinated process of planning, operating, maintaining, upgrading and

replacing assets cost effectively with minimum risk and at the desired level of customer service at the lowest life cycle cost for the purpose of achieving its organizational strategic plan. It can be used to help assure that utility services are provided in a sustainable, cost-effective way to assist and help to improve the quality of life of people.

Asset/Facility Management is not an accounting exercise or a substitute for quality management. It is for everyone working in a organization that owns or operates assets. This includes those working in procurement, finance, personnel, service, planning, design, operations, administration, leadership, marketing and sales. It is neither a project management system nor just about maintenance.

It is devoted to the coordination of space, infrastructure, people and organization, often associated with the administration of office blocks, public arenas, schools, sporting complexes, convention centre, shopping complexes, hospitals, hotels, etc. Facilities management practice is applicable for all class of assets, that is, retail, residential, commercial, industrial, warehousing and hospitality, etc.

If correctly implemented, facility management can deliver safe, productive, humane and cost effective environments in different spheres of people's living, commercial activities and working. This practice also enhances the skills of people within the facilities management sector, creates career opportunities, and enables new working styles which is important in this technologically driven world. All these benefits will not only enhance the organization's image and brand name but also make the infrastructures across class of assets a safe, healthy and productive place.

Asset/facility management includes the integration of the planning and management of a wide range of services both 'hard' (for example, building fabric and building services) and 'soft' (for example, catering, cleaning, security, and mailroom), the management of an increasingly broad range of tangible assets, support services as well as people skills.

The identified core competencies of the asset/facility management are:

- a) *Communication* — Communication plans and processes for both internal and external stakeholders;
- b) *Emergency preparedness and business continuity* — Emergency and risk management plans and procedures;
- c) *Environmental stewardship and sustainability* — Sustainable management of built and natural environments;
- d) *Finance and business* — Strategic plans,

- budgets, financial analyses, procurement;
- e) *Human factors* — Healthful and safe environment, security, facility management employee development;
- f) *Leadership and strategy* — Strategic planning, organization, staff and leadership organization;
- g) *Operations and maintenance* — Building operations and maintenance, occupant services;
- h) *Project management* — Overseeing and management of all projects and related contracts;
- j) *Quality* — Best practices, process improvements, audits and measurements;

NOTE — Management of only physical assets are covered in this Part.

The asset/facility management can be done either in-house or by engaging outside agency.

Asset management and facility management have overlapping aspects, these are therefore dealt with in this Part together and accordingly, in most cases the term ‘asset/facility’ has been used while in some other cases, the two terms have been used interchangeably.

3.3.1 General Issues Relating to Asset/Facility Management

Any asset/facility will have following stakeholders:

- a) Owner,
- b) Execution team,
- c) End user, and
- d) Maintenance or operation team (Operator).

All the four may be different entities or may be one. In any case it is essential to ensure that the best interests of all the stakeholders are served. This gets served when an asset/facility is maintained in such a manner that it performs the function or allows functions to be performed for which the facility was conceived.

The owner may be the operator of the asset/facility or another party may fulfil this role. In either case, it is important that the interests of the operator are taken into account from the outset. This interest extends to the needs of the end-users of the asset/facility. In larger organizations, an operations team, asset/facility management team or a facility manager is responsible for the asset/facility on a day-to-day basis. In smaller organizations, there may not be any equivalent provision. Nonetheless, someone has to provide expertise on operational matters and that may have to fall to a consultant engaged for this purpose. This person is necessary to provide comment and advice on the implications of design and construction proposals from

an operational perspective as they are developed from planning to the procurement strategy through to the handover and close-out work stage.

The operator, operations team or facility manager, as appropriate, should be given authority by the owner to contribute information concerning the operational strategy and operational requirements, including performance outcomes and targets, operational costs and budgets, and the procurement of facility related services where appropriate. The owner may agree that such contributions are channeled through the owner’s representative or they may be communicated directly to the design and construction team. In the latter case, the design and construction team should ensure that contributions are duly recorded and made available within the team. A responsible, accountable, supported, consulted and informed (RASCI) chart should be used to clarify responsibilities.

Effective asset/facility management, combining resources and activities, is vital to the success of any organization. At a corporate level, it contributes to the delivery of strategic and operational objectives. On a day-to-day level, effective facilities management provides a safe and efficient working environment, which is essential to the performance of any business – whatever its size and scope. Maintaining and developing services through the process of building maintenance, administration and contract management, maintaining communications infrastructure ensures that a facility gives value during its operational life.

Timely action and proper maintenance ensures continued serviceability during life of the asset/facility and gives better return on investment, ensures enhanced life of asset, continued safety and helps avoid risks of the asset/facility losing value and requiring greater amount of effort and finances to bring it back to a serviceable stage. It ensures that the asset continues to meet the standards which were set during design stage.

3.3.2 Strategy

An organization should formulate a facilities maintenance strategy and policy that meets its current and likely future needs. The strategy and policy should be reviewed, at least annually, to ensure that it continues to be aligned to the organization’s core business and primary processes. An organization should ensure that the needs of its stakeholders are identified and the impact of those needs is assessed and taken into account when formulating the strategy and policy. A communication plan to disseminate the strategy and policy, as well as tactical and operational actions, to stakeholders should be prepared by the organization. Details of annual, or more frequent, reviews to check on the alignment between actions and the organization’s facilities maintenance strategy should be included in the plan.

3.3.3 Stakeholder Engagement

Stakeholders should be involved in discussion about the arrangements for asset/facility management in general and facility-related services in particular in defining their needs and the level of performance that is acceptable. This task includes,

- a) involving stakeholders, as far as practicable, in identifying their needs through, for example, the use of questionnaire-based surveys and in contributing to the drafting of service specifications and service levels;
- b) identifying diversity of need such as when seeking to include people with disabilities or other individuals' specific needs;
- c) prioritizing the needs of stakeholders; and
- d) controlling stakeholder inputs and changes once service specifications and service levels have been agreed in order to avoid scope creep.

3.3.4 Effective Communication

Effective communication between the procurer and service providers (another stakeholder group) should be maintained to enable the implementation of an asset/facility management strategy (in terms of the broad approach to the procurement of services) which is both understood and capable of being acted upon. Clear and regular communication is required to develop relationships.

3.3.5 Performance Evaluation

It is imperative that the strategy for managing the asset/facility should be efficient and cost-effective in terms that are quantifiable. It may be advisable to set the following performance outcomes at the strategy work stage and monitored during each subsequent work stage up to operation and end of life, with post occupancy evaluation (POE) during a defined period of extended aftercare used as the basis for measuring operational performance:

- a) *Environmental* — The asset/facility should meet performance targets such as those for energy use, CO₂ emissions, water consumption and waste reduction or others defined by the owner and operator.
- b) *Social (that is, functionality and effectiveness)* — The asset/facility should be designed and constructed to meet the functional and operational requirements of the owner such as the overall concept, context, uses, access, visual form, space, internal environment, durability and adaptability, and in operation should meet the operator's and end-users' requirements of utility, usability,

safety, maintainability, security, inclusiveness and comfort.

- c) *Economic* — The asset/facility should meet performance targets for capital cost and operational cost, which should be considered side-by-side to enable whole-life costs to be calculated.

Outcomes and targets should be specific to the project and should be verified in each work stage.

3.3.6 Statement of Needs

Deliverables in the briefing process should include a statement of needs. A statement of needs embodies the owner's objectives and the extent to which they are likely to be satisfied by the facility. A functional brief is the interpretation of the statement of needs in the form of defined scope of work as a basis for design.

Internal and external stakeholders should be identified at the start of the briefing process and their interest in the facility should be assessed and documented. A stakeholder impact analysis should be undertaken to determine how, and the extent to which, stakeholder interests may impact on the facility in terms of its design, construction work and/or installation, testing and commissioning, handover and start-up of operations.

A statement of the owner's primary activities and primary processes should be prepared. This statement should provide details of how the facility is expected to contribute to the fulfilment of the owner's primary activities and should describe the processes to be carried out in or from the facility.

The space efficiency of the facility should be calculated, where applicable, and used to assess the owner's space provision over the anticipated lifetime of the facility. Allowance for growth and/or reduction in the demand for space and its phasing over the lifetime of the facility should be incorporated in the assessment of this provision.

Results of the stakeholder impact analysis used in assessing stakeholder interests in the facility should be made available to the designer if prepared by the owner or a third party. The results should show the nature, extent and relative importance of all expressed needs. Any prioritization should be made explicit. The statement should express the needs of the owner both in general terms and specifically in relation to the facility.

The statement of needs should be used to inform the provision of an operational facility. Information and data on the expected use of the facility, including technical solutions, should be prepared against criteria given in the statement of needs. The information and

data should be grouped as follows:

- a) Primary activities and processes to be accommodated by the facility;
- b) Operational demands and support processes for users; and
- c) Technical solutions, including the appraisal of options for satisfying identified needs.

This information is used, amongst other things, in planning the layout and arrangement of spaces and functions within the facility. There can be different ways of satisfying an identified need and these have to be made clear and supported by information and data for decision-making.

3.3.7 Importance of Asset/Facility Management System

Systems asset/facility management are vital for organizations that are dependent on the function and performance of their physical assets in the delivery of services or products, and where the success of an organization is significantly influenced by the stewardship of its assets. Asset/facility management is important because it can help organizations to,

- a) reduce the total costs of operating their assets;
- b) reduce the capital costs of investing in the asset base;
- c) improve the operating performance of their assets (reduce failure rates, increase availability, etc) and ensure continued serviceability during life of the asset;
- d) reduce the potential health impacts of operating the assets;
- e) reduce the safety risks of operating the assets;
- f) minimise adverse environmental impact of operating the assets;
- g) maintain and improve the reputation of the organization;
- h) improve the regulatory performance of the organization;
- j) reduce legal risks associated with operating assets;
- k) gives better return on investment (important from financiers point of view), enhanced life of asset, ensures continued safety; and
- m) it ensures that the asset continues to meet the standards which were set during design stage – the strategy for managing the asset/facility should be efficient and cost-effective in terms that are quantifiable.

The key to good asset/facility management is that it optimizes these benefits. That means that asset/facility management takes all of the above into account and determines the best blend of activity to achieve the best

balance for all of the above for the benefit of the organization. Asset/facility management is explicitly focused on helping organizations to achieve their defined objectives and to determine the optimal blend of activities based on these objectives.

4 ORGANIZATIONAL STRUCTURE OF AN ASSET AND FACILITY MANAGEMENT SYSTEM

The organizational strategic plan is the starting point for development of the asset/facility management policy, strategy, objectives and plans. Monitoring and continual improvements within the asset/facility management system is very important.

Organization setup for large facilities will be guided by the factors given below.

4.1 Scope of Work to be Carried Out

In general, asset/facility management will require carrying out necessary activities in various disciplines involved for covering all relevant aspects. For each discipline, the number of persons required at field level and supervisory levels will depend on the quantum of assets to be managed.

4.2 Competence of Staff at Various Levels

Asset/facility management work will need personnel with adequate and relevant expertise in each of the concerned disciplines at various levels.

4.3 Organization Roles at Various Levels

The top management has to ensure that the personnel at various levels are aware of their roles and responsibilities and an information communication system is in place to see that all activities specified for asset/facility management have been duly carried out at all levels.

4.4 Facility Manager

Normally functions of facility management are entrusted to a dedicated functionary termed as Facility Manager. He can be assisted by various skilled and unskilled persons as per facility requirements.

4.4.1 Functions of Facility Manager

Facility Manager is primarily concerned with operational planning and control of the activities covered under asset/facility management. This will involve various items as given under 4.4.2 to 4.4.4.

4.4.2 Persons Reporting to Facility Manager

They should be aware of their roles and responsibilities and procedures to be followed. Facility Manager has to see that adequate resources are made available to

them for carrying out the required activities. Where necessary, their competence is to be developed further so that they may carry out the present and future assignments successfully.

4.4.3 Control Mechanisms

The facility manager should put in place certain control mechanisms to ensure that,

- a) there is documentation to enable verification that the activities required were duly carried out and completed as required;
- b) there is documentation to enable verification that the risk management processes required were duly carried out and completed as required; and
- c) efforts are made to determine emerging risks and plan changes to asset/facility management well in advance, if required.

4.4.4 Management of any Change

During operational phase, there may be changes due to supply chain constraints in respect of materials or labour, or there may be competing demands on resources. New assets may also have to be managed. There may be a change in processes and so on. Efforts have to be made to foresee the changes and take timely action to avoid any disruption in asset/facility management processes.

4.5 Outsourcing

Certain items under the facility manager may have been outsourced. Facility Manager has to supervise those items with effective monitoring in order to ensure that the concerned agencies are discharging their responsibilities properly and performance is as planned, which should be supported by necessary documentation. The control of risks which cannot be transferred to outside agencies should be maintained with the Facility Manager.

5 METHODOLOGY

During the planning of the asset/facility management system, the resources required for the activities planned should be determined. These resources may be grouped broadly in the following two categories:

- a) In-house; and
- b) Outsourced.

The costs of activities required for asset/facility management should also be incurred under above two categories.

5.1 In-House Activities

Following aspects should be kept in view while

planning the activities required for asset/facility management as in-house activities:

- a) Cost to be incurred on salary and establishment expenses of regular staff will be more or less fixed depending upon the number of staff in various categories and the infrastructure required for them by way of office accommodation, tools and plants, equipment, etc. This expenditure will not vary much unless the number of staff or the quantum of equipment is varied depending on the work load.
- b) Generally, the quantum of works to be carried out is decided keeping in view, in addition to technical requirement, the availability of funds. Cost incurred on works will depend on the actual quantum of work carried out and is, therefore, variable.

5.2 Outsourced Activities

The procurer should determine the extent to which, if any, facility-related services are to be provided from within the organization and those services that are to be outsourced. Where both occur, account should be taken of the need to integrate the two sources of service delivery and the resources and costs that may be involved in managing such an arrangement. Consideration should be given to the interfaces between separate services, including any obtained from within the organization, so that end-users experience seamless service delivery.

5.2.1 Precautions to be Taken During Outsourcing

The advantage of managing activities with in-house resources is that the organization has direct control over the operations. However, when activities are outsourced, such direct control is not automatic. The organization shall assess the associated risks and shall ensure that outsourced processes and activities are controlled. There has to be a clear demarcation between the activities that have to be outsourced and the activities to be managed by the organization in-house. Arrangements have to be made for sharing the knowledge and information between the organization and the agencies with whom contract has been entered into for providing certain activities. Therefore, in case of outsourcing of certain activities, the organization shall lay down responsibilities and authorities within the organization for controlling such outsourced activities including monitoring of their performance.

5.3 Processes to be Adopted

Adequate staff having necessary training in carrying out various operations for ensuring required levels of cleanliness, serviceability, hygienic conditions, safety

and security of occupants under guidance of facility manager should be deployed. The Facility Management team should draw up plans for achieving the desired standards. It should also keep track of best practices developed elsewhere and is exposed to latest developments in this field.

6 RESOURCES REQUIREMENT FOR ASSET/FACILITY MANAGEMENT

6.1 Resource Assessment

A facility, and the individual assets that it comprises, should be maintained to deliver the most effective outcomes in terms of minimal cost and risk. Assets should be classified into risk categories, for example, small, medium, severe and critical, according to their potential impact on the core business of the organization in the event of failure in performance. The condition of assets should be determined and a decision made as to the most effective option for their maintenance.

The organization shall determine and provide the resources needed for the establishment, operation, and further improvement of the asset/facility management system; meeting the asset/facility management objectives and implementation of the activities specified in asset/facility management system. Information technology will help in making better use of resources, reduce risk of failure of essential services, and make available information for better future planning.

6.2 Resource Plan

A maintenance resource plan should be prepared for assets operating under normal (operating) conditions. This plan should be modified, where necessary, to reflect operating conditions within the facility that fall outside specified design requirements and/or tolerances. The plan should be capable of aligning with changes in demand for, or modes of, service delivery. For an existing facility, a condition assessment of the assets should be undertaken before preparing the maintenance resource plan, wherever practicable. The cost of implementing the plan should be estimated and adequate provision made within budgets. Once implemented, the plan should be monitored for effectiveness and performance, with adjustments made where appropriate to ensure that the requirements set out are met.

6.3 Need Assessment

An organization should align its service needs, including service dependency, utilization, location, capacity and functionality, and maintenance planning with the required level of facility asset performance. Where a new facility is being procured, an organization

should ensure that adequate provision is made during the design and construction phases to incorporate these requirements. Maintenance should be planned to take account of the maintenance cycle of each element/sub-element and inspections should be made at regular intervals (as determined by the properties of each element/sub-element and its anticipated service life). An organization's production and operational requirements should be integrated into the maintenance plan. Annual programmes of maintenance should take into account subsequent years' programmes so that additional costs or abortive works are minimised. Decisions to replace or repair components should be taken after due consideration of whole-life costs.

6.4 Adequacy of Resources

6.4.1 The resources available may be compared with the resources required. In case of shortfall in availability as compared to requirement, the shortfall may be met by one or more of the following options:

- a) Augmenting in-house resources;
- b) Augmenting outsourced resources; and
- c) When resources cannot be augmented, say, due to non-availability of requisite funds, postponing the requirements which are not so urgent.

6.4.2 Following factors affect the choice of the category of resource required for various activities:

- a) *Competence of staff*— It is to be seen whether the requisite competence is available with the staff available in-house, or it is necessary to arrange the same by outsourcing. Where required, the competency needs should be met by provision of training to the available persons, or hiring or contracting of competent persons. The following shall be taken care of,
 - 1) The organization shall determine the required level of competence of persons doing work under its control that affects its asset performance, asset/facility management performance and asset/facility management system performance.
 - 2) The organization shall ensure that the persons engaged on its works are competent on the basis of appropriate education, training or experience.
 - 3) Where required, action should be taken to see that the concerned persons acquire the requisite competence by further training, etc.
 - 4) Adequate documented information shall be kept as evidence of competence of concerned persons.

- 5) The organization shall periodically review current and future competency needs.
- 6) Staff is aware of their job requirement and expected deliverables.
- b) Persons doing work under the organization's control, who can have an impact on the achievements of the asset/facility management objectives, shall be aware of,
 - 1) the asset/facility management policy;
 - 2) their contribution to the effectiveness of the asset/facility management system, including the benefits of improved asset/facility management performance.
 - 3) their work activities, the associated risks and opportunities and how they relate to each other.
 - 4) the implications of not conforming to the asset/facility management system requirements.
- c) *Tools, plant and machinery* — Certain maintenance operations may require tools, plants and machinery, which may or may not be available in-house. In case of non-availability in-house, it has to be decided whether the same should be procured or the work outsourced.

7 PROCUREMENT OF ASSET/FACILITY RELATED SERVICES

7.1 Roles, Responsibilities and Accountabilities

One of the functions of asset/facility management is to determine which procurement option, or combination of options, for the delivery of maintenance-related services best fits the core business and primary processes of an organization. It is important for organizations to understand the full maintenance requirements and the capability and capacity required to deliver these services.

Procurement of facility-related services should be regarded as a distinct function within the procurer's organization and, as such, should be covered by a designated role. Formal systems, processes and procedures should be assessed to determine whether or not arrangements covering facility related services have been included and, if so, how these may apply.

The procurer should determine where responsibilities and accountabilities rest with respect to defined roles in the procurement of facility-related services. Where tasks to be performed fall outside existing roles, the organization should consider designating additional personnel for this purpose. The need for expert advice from external sources to supplement any lack of internal

skills and competence should be ascertained. Where found necessary, additional roles should be defined and incorporated alongside those existing. The procurer should identify all roles that are connected with the function of procuring facility-related services and ascertain their nature and the relationship between them. Where the procurer is unable to fulfil required roles, the appointment of a managing agent (or other consultant) should be considered.

7.2 Planning for Procurement

A plan of the procurement process should be prepared to identify the stages involved and activities within them. The plan should take the form of a schedule in which stages, planned activities and their resources, decision points and milestones are shown against a time-scale.

Planning for procurement is a project in its own right. Resources include finance, budgets, human resources, consumables, equipment and information technology. Milestones cover commencement dates, completions and deadlines. Approvals and other key decisions are better considered as activities having durations and not as milestones since they are rarely, if ever, instantaneous events. The plan should complement existing processes and procedures, and align with the requirements of corporate governance. The procurement plan should identify:

- a) Stages and decision points in the procurement process;
- b) Criteria for decision-making;
- c) Activities within stages and their sequence;
- d) Sources of information and data to be used in activities;
- e) Individuals and external organizations to be involved in activities and their roles;
- f) Other stakeholders who may be involved;
- g) Resources needed to support the activities; and
- h) Deliverables at each stage and the form they should take.

The plan should incorporate the tendering process and procedures to be adopted.

7.3 Pre-qualification

A request for proposal (RFP) or a pre-qualification quotation (PQQ) should be prepared by the procurer and reflect, as a minimum, the following:

- a) Legal form and ownership of the service provider;
- b) Areas of specialization, competences and technical skills;
- c) Proposed approach to service delivery (that is, method of work);

- d) Extent of subcontracting;
- e) Relevant track-record (based on evidence of similar contracts);
- f) Financial capacity and dependency;
- g) Organizational organogram ;
- h) Health, safety, security and sustainability policies, procedures and practices;
- j) Commitment to provisions on access, inclusion and equality;
- k) CSR policy and initiatives;
- m) Alignment with the procurer's business process and systems; and
- n) Basis for assessing overall suitability (including criteria, scoring and any weightages to be applied).
- p) Training infrastructure

The RFP/PQQ may be undertaken in two parts: firstly, through a preliminary evaluation which is used to determine and filter out any service providers that are clearly unsuitable; and, secondly, through a detailed evaluation aimed at objectively assessing the ability of prospective service providers. Any preliminary evaluation should enable the procurer to quickly establish the suitability of service providers, enabling them to focus attention on those best qualified to deliver the service.

NOTE — Standard procedures for call of tenders may be as well established by respective organizations, for example, ones under two/three envelope system.

The procurer should determine the number of service providers that it wishes to invite to submit an RFP/PQQ. A maximum and minimum number should be set. The procurer should determine if, at the end of the RFI stage, it lacks information to specify all of its facility-related services and required levels of performance. In such a case, it should make arrangements to gather that information before proceeding to a request for proposal (RFP).

7.4 Financial Appraisal

All prospective service providers, irrespective of specialization or size, should be treated fairly and with equal diligence during the financial appraisal process. As a minimum consideration, the following should be undertaken:

- a) Inspection of the financial accounts for the past three years of trading (in the absence of audited statements, other information that demonstrates the service provider's financial standing should be sought); and
- b) Assessment of the service provider's ability and capacity to deliver the service at the current estimated contract value.

Where the procurer considers that its knowledge of the market is underdeveloped, it should investigate the availability of prospective service providers and the extent to which they may cover the identified scope of facility related services. The procurer should engage in direct enquiries with service providers and/or the trade associations or other bodies that represent them. Market testing should represent a genuine attempt to engage existing and prospective service providers in discussion about approaches to service delivery.

The procurer should consider the benefits of seeking indicative cost estimates to guide decision-making.

7.5 Centralized Versus De-centralized Management of Service Contracts

Where the procurer has both centralized and de-centralized management with respect to procurement, it should state its position and policy in regard to services that may be procured locally and those that may only be procured centrally and *vice-versa*. Note should be taken of the arrangements for day-to-day management of service contracts and authorities for contract awards, approval of payments and significant changes in the scope of contracts or their value. Where there is a requirement for pre-qualification for the purpose of inclusion in a list of tenderers, policy in this regard should be made clear both centrally and locally.

7.6 Geographical Location and Limits

By examining needs in regard to the provision of facility-related services, in particular attributes of service, the procurer should be able to achieve a clear understanding of what is important in service delivery. The procurer should consider the extent to which the local market is able to offer the planned services and the geographical limits that are acceptable when considering the suitability of a prospective service provider.

7.7 Single/Multiple Service Contracts

The procurer should explore the combinations of services that can be delivered by prospective service providers with regard to the defined scope and the relationships and interfaces between the services. Account should be taken of the ability of service providers based on evidence of performance and/or reference sites.

7.8 Local, Regional and National Service Providers

The procurer should determine the extent to which the market locally, regionally or nationally has the capacity to satisfy needs. Account should be taken of the specialization, number and size of service providers

able to offer the planned services. Informal enquiries directed to prospective service providers may reveal the extent to which they are in a position to undertake new work, although care should be exercised when making judgments as to their capacity to do so.

7.9 Award of Works and Monitoring

The work shall normally be awarded to lowest responsible bidder whose bids are found to be responsive and is capable of delivery. Proper monitoring system shall be put in place to ensure quality work, as per work schedules and within budget estimates.

8 CLASSIFICATION OF ASSET/FACILITY MANAGEMENT

8.1 Typically asset/facility management can be classified into two areas of ‘hard’ and ‘soft’ services. The scope is extremely varied and services are likely to include hard services and soft services as given under **8.1.1** and **8.1.2**, respectively.

8.1.1 Hard Services

Hard services basically include building fabric maintenance, building services maintenance, such as plumbing, heating, ventilation and air conditioning (HVAC), electrical installations, lifts and escalators, etc.

MEP equipment provide essential service and make the building/facility safe and workable it is most essential that all the systems installed in any building/facility are maintained in good running/operating condition. Shortcoming in maintenance can lead to disruption of essential service and lead to impacting adversely the working within the facility therefore downtime should be minimised. All these services have to be carried out as per the type and usage of the facility.

For large or sensitive installations/facilities, it will be desirable to co-opt the facility management team at planning and design stage and utilize their inputs during the lay-out/design of building fabric and services, which can ultimately lead to easier and better functioning. Selection of materials, system, which have proved to be easier to maintain should be considered while making selection at project execution stage.

Some of these hard services, which are covered in this Part include,

- a) building fabric maintenance (including addition/alteration and refurbishment) (*see 10*);
- b) building services maintenance:
 - 1) Plumbing and drainage (*see 11*);
 - 2) Air conditioning, heating and mechanical

- ventilation (HVAC) services (*see 12*);
 - 3) electrical installations (*see 13*);
 - 4) lifts and escalators (*see 14*); and
 - 5) fire fighting-detection and suppression (*see 15*); and
- c) Roads and pathways (*see 16*).

8.1.2 Soft Services

Soft services, such as housekeeping, pest control, waste management, security, valet services, office support services, etc, are as essential a part of asset/facility management as maintaining hard services.

All these soft services have to be carried out as per the type, usage of the facility and may vary considerably. For instance services and service standards for a hotel, hospital or shopping malls/complexes may be quite different from those required for a standalone residence. A considered call on this has to be taken by the owner and the standards required to be achieved have to be communicated to the facility management team.

Some of these soft services, which are covered in this Part include,

- a) environment, health and safety (*see 17*);
- b) landscaping and horticulture waste management (*see 18*);
- c) housekeeping (*see 19*);
- d) pest control (*see 20*);
- e) security management (*see 21*); and
- f) solid waste management (*see 22*).

8.2 Asset/facility management in respect of common areas in a building and built environment should also take care of the provisions of **9.13**.

8.3 Various services, whether hard or soft, require understanding of different aspects, methodologies and management of maintenance, which have been detailed in **9**.

9 BUILDING MAINTENANCE — METHODS AND MANAGEMENT

9.1 General

Any building (including its services) when built has certain objectives and during its total economic life, it has to be maintained in proper condition to meet those objectives. Maintenance is a continuous process requiring a close watch and taking immediate remedial action. It is interwoven with good quality of housekeeping. It is largely governed by the quality of original construction. The owners, engineers, constructors, occupants and the maintenance agency are all deeply involved in this process and share a responsibility. Situation in which all these agencies

merge into one is ideal and most satisfactory. There are two processes envisaged, that is, the work carried out in anticipation of failure and the work carried out after failure. The former is usually referred to as preventive maintenance and the latter as corrective maintenance. The prime objective of maintenance is to maintain the performance of the building fabric and its services to provide an efficient and acceptable operating environment to its users.

Maintaining a building is expensive; it costs many times more to run a building over its lifetime than to build it, yet maintenance is often not accorded the priority it warrants. A poorly maintained building will be a drain on resources and will impair building use, whereas a well maintained building will function smoothly and represent an appreciating asset to its owners. A professional approach is therefore required to building maintenance.

Though the building may be designed to be very durable it needs maintenance to keep it in good condition. Whereas construction stage lasts for a short period, maintenance continues for comparatively very large period during the useful life of building. Inadequate or improper maintenance adversely affects the environment in which people work, thus affecting the overall output. In the post construction stage the day to day maintenance or upkeep of the building shall certainly delay the decay of the building structure. Maintenance management of building is the art of preserving over a long period what has been constructed

9.1.1 The objective of maintenance is,

- a) to preserve building and services, machinery in good operating condition;
- b) to restore it back to its original standards; and
- c) to improve the facilities depending upon the development that is taking place in building and services engineering.

9.1.2 Maintenance in general term can also be identified in the following broad categories:

- a) *Cleaning and servicing* — This is largely of preventive type, such as checking the efficacy of rain water gutters and servicing the mechanical and electrical installations. This covers the house keeping also.
- b) *Rectification and repairs* — This is also called periodical maintenance work undertaken by, say, annual contracts and including external replastering, internal finishing, etc.
- c) *Replacements* — This covers major repair or restoration such as reproofing or re-building defective building parts.

9.2 Maintenance Methods

An organization should determine which method or combination of methods best satisfies its operational needs in maintenance in accordance with its facilities maintenance strategy and policy. Each method should be assessed in terms of the extent to which it satisfies (or does not satisfy) the criteria defined as part of the facilities maintenance strategy. When taking into account asset criticality and monitoring capacity within the facility, the benefit of combining methods should be evaluated.

There are a number of methods of maintenance; these can be grouped into two broad categories (*see also* Fig. 1):

- a) Planned maintenance, which includes planned preventive maintenance and shutdown maintenance. Preventive maintenance further includes condition-based maintenance, reliability centred maintenance (RCM) and total productive maintenance (TPM); and
- b) Unplanned maintenance, which includes corrective maintenance, breakdown maintenance and emergency maintenance.

9.2.1 Planned Maintenance

9.2.1.1 Planned preventive maintenance or scheduled maintenance

This method allows maintenance activities to be organized and carried out with forethought, control and records to a predetermined plan, based on the results of condition surveys. This method aims to avoid or to mitigate the ‘consequences of failure’ and to minimise maintenance-induced failures and their associated costs. It is based on the criticality of failure to the organization and is also known as scheduled maintenance.

Planned preventive maintenance is further classified into following categories:

- a) *Condition-based maintenance* — This method of maintenance is based on the results of condition monitoring of building, plant, equipment, systems and elements to avoid loss of function or failure. Condition-based maintenance is performed by selecting and monitoring a parameter which, for example, indicates plant condition. Data are collected and analysed and required maintenance is determined from the findings. This work can be carried out continuously, periodically or on demand in real time and is often used for remotely monitoring plant condition.
- b) *Reliability centred maintenance* — Reliability centred maintenance is a systems-based method used to determine maintenance tasks

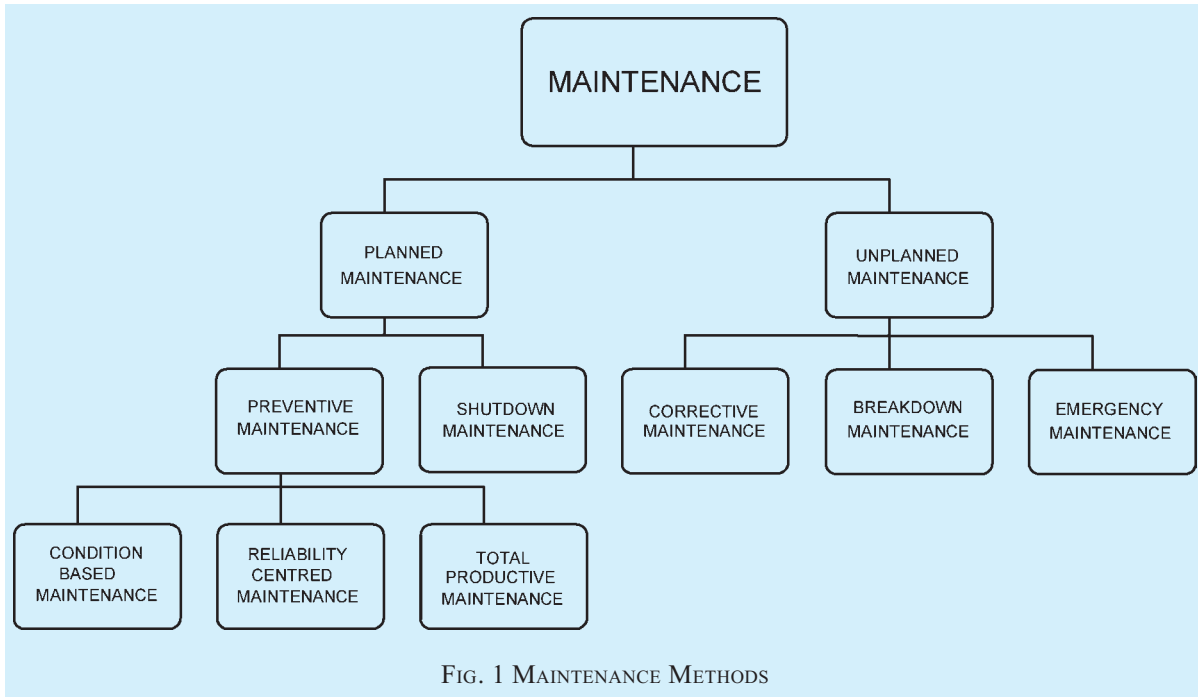

FIG. 1 MAINTENANCE METHODS

needed to ensure that a facility asset or system continues to function in order to fulfil its purpose as designed in its present operating condition. The method can involve the implementation of asset condition monitoring, based on the advance provision of an asset register.

- c) *Total productive maintenance* — Total productive maintenance is a systematic approach to improving maintenance effectiveness, which operates at the tactical level and normally builds on the successful implementation of strategic methods. The method also involves the implementation of asset condition monitoring, based on the advance provision of an asset register.

9.2.1.2 Planned shutdown maintenance

This method is normally used for continuous process production and manufacturing facilities, where a detailed plan is produced for all assets for work to be carried out during a total shutdown.

9.2.2 Unplanned Maintenance

9.2.2.1 Corrective maintenance

Maintenance initiated as a result of the observed or measured condition of plant, equipment, systems, elements, before or after a functional failure, can be used to resolve the problem and ensure correct functional performance. This work can be planned or unplanned.

9.2.2.2 Breakdown maintenance

Breakdown maintenance relates to the task of restoring an asset so that it can fulfil its original function after failure. This method may result in high replacement costs over the lifetime of the asset, but has a low initial maintenance resource requirement. It is sometimes used for simple facilities that have few operatives and no critical environments to support.

9.2.2.3 Emergency maintenance

This maintenance method results from a sudden, unforeseen occurrence requiring immediate corrective work to be carried out to restore to function and to avoid potentially serious consequences.

9.3 Cost Effectiveness

The facility manager has to work out the cost effectiveness of the method adopted taking into account the resources availability, criticalness of services and cost trade off to determine the frequency and level of maintenance to be ensured. Impact of various factors on costs involved and degree of maintenance services achieved is shown in Figs. 2 to 4.

9.4 Aspects Influencing Building Maintenance

9.4.1 Maintenance of the buildings is influenced by the following factors:

- a) *Technical factors* — These include age of building, nature of design, material specifications, past standard of maintenance and cost of postponing maintenance.

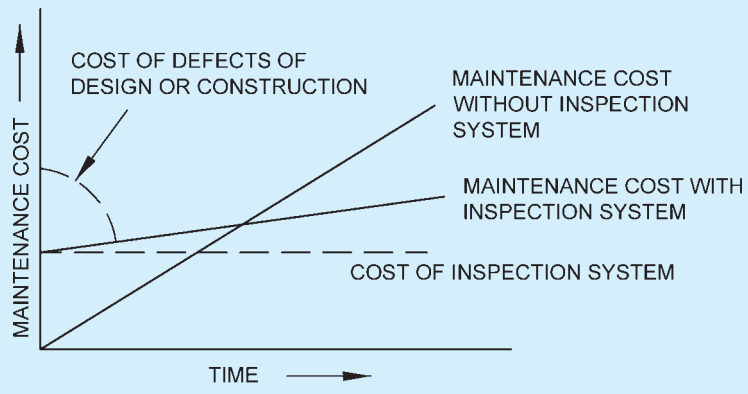

NOTES

1 In general maintenance classification may be as:

- a) Major repair or restoration,
- b) Periodic maintenance, and
- c) Routine or day-to-day maintenance.

2 A system which is based on planned inspections and maintenance will have higher overhead costs than the one that is not, but the planned inspection lead to lower maintenance expenditure.

FIG. 2 COST RELATIONSHIP BETWEEN PLANNED AND UNPLANNED SYSTEM

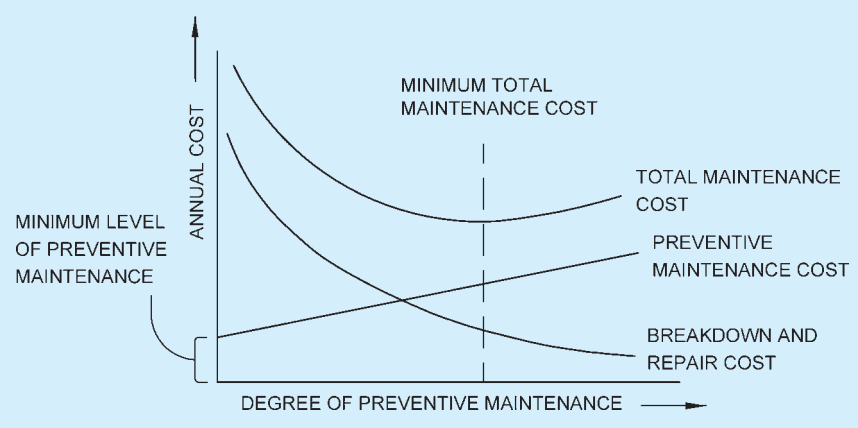

FIG. 3 TRADE-OFF BETWEEN REPAIRS AND PREVENTIVE MAINTENANCE

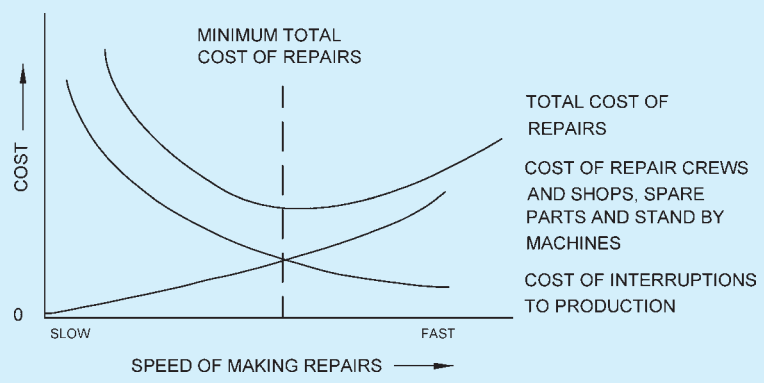

FIG. 4 SPEED OF MAKING REPAIRS

- b) *Policy* — A maintenance policy ensures that value for money expended is obtained in addition to protecting both the asset value and the resource value of the buildings concerned and owners.

A maintenance policy should be developed to support the preparation of operational plans in accordance with the maintenance strategy. The policy should outline the scope and course(s) of action that should be taken to achieve an organization's goals. The maintenance policy should embody the principle of best value for money to protect both the asset value and the resource value of the facility. The policy should cover,

- 1) the organization's anticipated future requirements for the facility, taking into account the facility's physical performance and functional suitability, for example:
 - i) The use of the facility, that is, anticipating likely upgrades and the effect on the life cycles of existing materials, components and engineering installations;
 - ii) A change of use for the facility and the effect of any conversion work on the life cycles of existing materials, components and engineering installations; and
 - iii) The anticipated date of conversion, renovation or refurbishment work.
 - 2) any cycles of maintenance determined in accordance with (a);
 - 3) the method of maintenance, taking account of cycles of maintenance together with the requirements of the organization with respect to the use of the facility and any special requirements to which this may give rise;
 - 4) holding spare parts and other items to replace those that are beyond repair or which have exceeded their useful life; and
 - 5) the means for reporting on performance achieved.
- c) *Financial and economic factors* — The planning and control of finance is an important aspect of maintenance management not only for the control of maintenance but also to demonstrate that the owners are getting value for money and that the maintenance proposals justify the funds requested.

Financial considerations start with the

development of maintenance programmes and the preparation of budget proposals. They also include the preparation of the detailed maintenance programme following the allocation of budget funds. These will involve decisions regarding optimum repair reaction time and the choice of the most appropriate method of execution (directly employed).

- d) *User* — the maintenance requirements of buildings and their various parts are directly related to the type and intensity of use they receive and the people who use these facilities especially those with disabilities, elderly and children in particular.

9.4.2 *Other Factors Affecting Maintenance*

9.4.2.1 *Health and safety*

9.4.2.1.1 *General*

The management of occupational health and safety has to be viewed as an integral component of facilities maintenance management and not as a separate function or as an add-on.

An organization should assess risks and other hazards at all stages in a facility's life cycle. Identified risks should be monitored and, wherever possible, their potential impacts should be mitigated. An organization should implement a formal system of risk management, including establishing and maintaining a risk register. Periodic reassessment of risks should be undertaken to update the risk register and associated risk mitigation.

9.4.2.1.2 *Initial review*

An initial review should be undertaken to provide information on the appropriateness, efficiency and effectiveness of existing health and safety management systems. Where no formal, or a minimal, health and safety management system exists (such as when an organization is newly established or when carrying out new activities) the initial review should be used as a base from which to develop a new system.

9.4.2.1.3 *Risk control and corrective actions*

An organization should implement risk control, as an integral part of its risk management, to ensure that control measures remain in place and that they remain efficient and effective. The risk management system should allow, as a minimum, for the following:

- a) Identification of health and safety hazards arising from maintenance and other work determined by workplace inspections, behavioural observations, tours, and formal and informal discussions with the workforce;
- b) Identification of people who may be at risk

from maintenance, for example, maintenance personnel, occupants, visitors, passers-by, trespassers, persons with disabilities, elderly people and children;

- c) Evaluation of the risks to which individuals and/or an organization may be exposed;
- d) Devising ways to eliminate, reduce and/or control risks, for example guarding and fencing, method statements, safe systems of work, permit-to-work, training and supervision;
- e) Monitoring and recording the effectiveness of risk control measures and systems, for example inspections, observations, safety tours and checklists;
- f) Taking coordinated corrective action;
- g) Providing feedback to the workforce and other stakeholders;
- h) Training, together with health and safety checks, of operatives; and
- j) Auditing and reviewing the system and, therefore, health and safety performance.

9.4.2.2 *Environmental factors*

9.4.2.2.1 *External*

An organization should assess the extent to which external environmental factors can influence the condition of the structure, fabric, engineering installations, fixtures and external finishes, and take such factors into account when drawing up maintenance plans. This should also include control of moisture. Swimming pool structures are vulnerable to the effects of chlorine used in water.

9.4.2.2.2 *Internal*

Humidity, temperature and pollution are factors that can adversely affect the condition of the structure, fabric, engineering installations, fixtures and internal finishes. The effects of intermittent heating and condensation can be particular problems.

An organization should assess the extent to which internal environmental factors, as well as the level of maintenance, influences the condition of the structure, fabric, engineering installations, fixtures and internal finishes. These factors should be taken into account when maintenance plans are drawn up. Factors that have a damaging effect on physical conditions, for example control of moisture, static electricity, as well as any unintended consequences for maintenance personnel, occupants and other users of the facility, should also be taken into account.

9.4.2.2.3 *Materials and components*

When drawing up maintenance programmes and plans,

including inspection schedules, the likely maintenance cycle of each element/sub-element (in accordance with the known quality of the materials and components employed and their manufacturers' recommendations where available) should be incorporated. The following need special attention:

- a) Potentially hazardous materials and components such as:
 - 1) Those containing asbestos;
 - 2) Lead, which may be present in some paint or be used for pipes carrying potable water;
 - 3) Materials that are either highly combustible or give off large quantities of smoke and fumes when involved in an established fire or in confined spaces (for example electrical risers); and
 - 4) Areas that should operate under a permit-to-work system.
- b) Types or methods of construction that, under certain circumstances, may become dangerous.
- c) Finishes and decorations, including their protection and treatment, where required.

9.5 **Influence of Design**

9.5.1 The physical characteristics, the life span and the aesthetic qualities of any building depend on the considerations given at the design stage. All buildings, however well designed and conscientiously built, will require repair and renewal as they get older. For better performance of the building envelope the following ways help to minimise troubles at later stage.

- a) Due attention be paid to maintenance requirements of the facility from the planning stage. The agency which is likely to be entrusted with the work of subsequent maintenance and upkeep of the facility should be involved from the design stage itself. Their inputs will be very valuable in ensuring economical maintenance during the lifetime of the facility. This aspect needs greater attention as the defects that are built in at planning stage are difficult to be addressed at subsequent stages.
- b) Detail and choose materials during construction so that the job of maintenance is less onerous.
- c) Specifications adopted should be practical and based on local practices. Durability considerations and maintenance of various areas should be kept in view.
- d) In addition to initial costs and life, type of

finish achieved and fire and life safety requirements should be built in at the time of design.

- e) Detailing of components should be done to ensure that they are conducive to effective operation and maintenance
- f) Accessibility for maintenance purposes of areas and services requiring maintenance is taken care of. It is necessary that service personnel are able to reach the service easily, safely, have adequate working space, safe working conditions and adequate lighting provisions. Cleaning of façade and replacement of glass panes needs to be kept in view while finalizing exteriors.
- g) In addition to designing a building for structural adequacy, consideration should also be given to environmental factors such as moisture, natural weathering, corrosion and chemical action, user wear and tear, pollution, flooding, subsidence, earthquake, cyclones etc.
- h) Design phase should cover such items as the owner's anticipated future requirement for the building taking account of the building's physical performance and its functional suitability. This may lead to decisions regarding,
 - 1) a change of use for the building and the effect of any conversion work on the life cycles of existing components or engineering services; and
 - 2) availability of replacements.
- j) The present use of the building anticipating any likely upgrading and their effect on the life cycles of existing components or engineering services.

9.5.2 During construction stage it should be ensured that suitable construction techniques are adopted, adequate quality control measures are taken, special attention is paid to services and testing of lines, effective supervision throughout and sound remedying of defects is ensured.

Need of good workmanship needs no emphasis. Proper detailing of elements and various fittings and fixtures will ensure good workmanship and quality work which in turn will not only give longer life to the facility but will ensure their long term functional service.

9.5.3 A list of common causes for maintenance problems is given in Annex A for guidance. However, no such list is likely to be entirely comprehensive.

9.6 Maintenance Planning

9.6.1 General

Maintenance plans should be driven by and support the intended outcomes stated in the facilities maintenance policy and strategy and should be fully aligned with them. Maintenance plans should be prepared in consultation with stakeholders, taking account of the following as a minimum:

- a) Organization's requirements for production and operational demands and constraints;
- b) Organization's financial circumstances and/or taxation position; and
- c) Feedback data on maintenance outcomes, including associated costs. Multi-year programmes of maintenance should be put in place where appropriate, that is, for long-term planning, finance or other expediency. Programmes should state a review date for assessing progress and performance.

When formulating maintenance plans, alternate maintenance methods should be evaluated. The links between the selected maintenance method(s), maintenance performance, facility asset performance and service delivery should be established through metrics, such as, key performance indicators (KPIs), based on a practical and effective maintenance process.

9.6.2 Assessment of Maintenance Planning

An organization should assess the benefits of maintenance planning, basing the assessment on the following:

- a) Contribution to the organization's goals;
- b) Satisfaction of stakeholder interests;
- c) Effectiveness of the facility in supporting the organization's operational plans;
- d) Availability and reliability of the facility at minimal cost;
- e) Capital and tax planning;
- f) Asset/facility management strategy;
- g) Protection of the value of facility assets;
- h) Provision of data on facility asset performance;
- j) Provision of data for maintenance benchmarking;
- k) Provision of data for continual process improvement;
- m) Provision of data on environmental performance;
- n) Basis for service life planning;
- p) Contribution to energy management;
- q) Contribution to business continuity management;

- r) Basis for service level agreements;
- s) Transparency and sound governance in financial reporting;
- t) Identified security risks;
- u) Awareness environmental sustainability;
- v) Improvement of outsourcing and collaboration agreements;
- w) Contribution to the facilities management strategy;
- y) Contribution to total quality management; and
- z) Contribution to procurement and supply chain management.

9.6.3 Maintenance Planning Process

While taking up maintenance planning, following should be kept in consideration:

- a) Facility assets required to support the core business and the delivery of services should be defined;
- b) Required level of facility asset performance, including performance indicators, should be agreed;
- c) Condition and sufficiency of facility assets for their intended purpose should be audited;
- d) Scope of the maintenance required should be identified through gap analysis;
- e) An appropriate maintenance method from those available should be selected;
- f) Resources required for the chosen maintenance method should be assessed;
- g) Maintenance plans and budgets should be prepared to cover the required scope of services over the short, medium and long term;
- h) A tactical plan for delivery of maintenance should be formulated;
- j) Resources to deliver the scope of maintenance should be provided;
- k) Maintenance plans and programmes of work are implementable;
- m) Performance monitoring, review and control of maintenance plans and programmes of work should be carried out.

Information and data gathered from this process should be used to re-inform the organization's need for, and use of, facility assets during this and any future iterations, of this process.

9.6.4 Financial Management

Maintenance budgeting is directed to keeping building in appropriate condition by the most economic means and each aspect of maintenance policy bears on cost. In maintenance budgeting, there are two prime elements

relating to what to budget for and how to assess its cost.

Financial control is an important aspect of maintenance management; this ensures that maintenance proposals justify the funds requested and that organizations obtain best value for money.

A maintenance strategy, and its associated maintenance programme(s), should include estimates of the cost of known work and provision for work that may be required but where the extent is unknown. These estimates should be used as the basis for preparing budgets for maintenance in line with an organization's overall financial planning and management accounting requirements. Budgets should include, but are not limited to, repair/replace decisions, the optimization of planned preventive maintenance, surveying/inspection costs and whole-life costs. Budget proposals should be presented in a way that identifies,

- a) the impact on capital value;
- b) the costs and benefits that accrue from the funds required;
- c) the risks and associated costs of not carrying out maintenance programmes in accordance with the maintenance strategy; and
- d) the costs and benefits of repair against refurbishment and against replacement and the basis of calculation, for example, net present value (NPV).

In the case of outsourced contracts, the contract sums and the costs associated with the management of the contracts, should be prepared. An audit should be carried out in each financial year to ascertain the extent to which best value for money has been obtained from the funds expended in the previous year on maintenance and to determine if any changes are needed to improve value for money.

It will be a good practice to carry out during the following financial year, a technical audit to ascertain the extent to which value for money was obtained from the funds expended in the previous year and what improvements in management may be made to improve cost benefits.

Guidelines relating to estimation of expenditures for maintenance as in 9.11.2 may be used.

For details, *see* good practice [12(1)].

9.7 Maintenance Work Programmes

The programming of maintenance work can affect an owner or his activities. Following aspects need consideration:

- a) Maintenance work should be carried out at

such times as are likely to minimise any adverse effect on output or function.

- b) Programme should be planned to obviate as far as possible any abortive work. This may arise, if upgrading or conversion work is carried out after maintenance work has been completed or if work such as rewiring is carried out after redecoration.
- c) Any delay in rectifying a defect should be kept to a minimum only if such delay is likely to affect output or function. The cost of maintenance increases with shortening response times.
- d) Maintenance work, completed or being carried out should comply with all statutory and other legal requirements.

9.7.1 Maintenance Guides

An owner responsible for a large number of buildings may have established procedures for maintenance. When an owner is responsible for the maintenance of only one building or a small number of buildings, the preparation of a guide tailored to suit each particular building, can offer significant advantages. Such a guide should take into account the following:

- a) Type of construction and residual life of the building, and
- b) Environment and intensity of use.

The guide may form part of a wider manual covering operational matters.

9.7.2 Feed Back

9.7.2.1 Feedback is normally regarded as an important procedure of providing information about the behaviour of materials and detailing for the benefit of the architect/engineer designing new buildings, which will result in lessening maintenance costs. It is an equally valuable source of information for the persons responsible for maintenance. Every maintenance organization should develop a sample way of communicating its know-how, firstly for benefit of others in the organization and secondly for the benefit of the building industry as a whole. There should be frank and recorded dialogue on an on-going basis between those who occupy and care for buildings and those who design and construct them.

9.7.2.2 Feedback should aim at the following:

- a) User satisfaction, particularly from diversity of users, such as women, elders and person with disabilities;
- b) Continuous improvement, and
- c) Participation by all.

9.7.2.3 Source of information

The information on feedback can be obtained from the following:

- a) Occupants,
- b) Inspections,
- c) Records, and
- d) Discussions.

9.8 Means of Effecting Maintenance

9.8.1 Responsibility

Some maintenance work will be carried out by the occupier of a building or by the occupier's representative. In the case of leasehold or similar occupation not all maintenance may be the responsibility of occupier. Responsibility of common areas, as need to be clearly defined (*see 9.13*).

9.8.2 The owner/occupant is primarily responsible for ensuring meeting minimum requirements of maintenance and upkeep as specified in **9.12**. Maintenance work sub-divided into major repair, restoration, periodical and routine or day-to-day operations may be undertaken by one of the following:

- a) Directly employed labour,
- b) Contractors, and
- c) Specialist contractors under service agreement or otherwise.

9.8.3 The merits of each category for typical maintenance work shall be considered because optimum use of resources appropriate to tasks in a given situation is an important element of policy.

9.8.4 The success of contracting out depends on the nature of the services, conditions in which contracting is undertaken (the tendering process), how the contract is formulated and subsequent monitoring of service quality. The important consideration in the decision to contract out is whether a contractor can ensure a socially desirable quantity and quality of service provision at, a reasonable cost to the consumers.

9.9 Access for Maintenance

9.9.1 General

All maintenance activities including any preliminary survey and inspection work require safe access and in some situations this will have to be specially designed. Maintenance policy, and maintenance costs, will be much influenced by ready or difficult access to the building fabric and to building services. Special precautions and access provisions may also need to be taken for roof work or for entry into confined spaces such as ducts or voids.

9.9.2 Access Facilities

Permanent accessibility measures should be provided at the design stage only for all the areas for safe and proper maintenance. It is a matter on which those experienced in the case of the building can make an important contribution at design stage in the interest of acceptable maintenance costs.

A wide variety of temporary access equipment may appropriately be provided for maintenance work, ranging from ladders to scaffoldings or powered lift platforms.

Wherever possible, it is better to provide permanent access facilities, such as fixed barriers, ladders, and stairways. When such permanent access facilities are provided necessary arrangement may be included in maintenance plans for their regular inspection, maintenance and testing.

All personnel employed for carrying out maintenance should be provided with the necessary protective clothing and equipment and instructed in its use.

When physical access is not possible in situations such as wall cavities, drains, etc, inspections may be made with the aid of closed circuit television or optical devices such as endoscopes.

9.9.3 Access to Confined Spaces

Following should be ensured for facilitating maintenance in confined spaces:

- a) *Ventilation* — Special precautions need to be taken when entering a confined space. Such confined spaces should be adequately ventilated, particularly before being entered, to ensure that they are free from harmful concentrations of gases, vapours other airborne substances and that the air is not deficient in oxygen.
- b) *Lighting* — Good lighting is necessary in order that maintenance work can be carried out satisfactorily. This is particularly important in confined spaces. When the normal lighting is inadequate it should be supplemented by temporary installations. These should provide general and spot illumination as appropriate.

9.10 Performance Management

9.10.1 General

Performance management involves monitoring, controlling and improving the efficiency and effectiveness of maintenance management and applies to both internal and outsourced arrangements. Various models, methods and tools are available to assist in the measurement of performance and in indicating where

improvement is required; examples include, but are not limited to, value management.

Performance management can be used as a means to foster efficient and effective working relationships between the parties of a contract or agreement relating to maintenance and/or its management, with the aim of achieving continual improvement in performance. It is not intended to be used as the basis for penalizing contractors or service providers, but instead to encourage better performance. Requirements for performance management should be formulated as part of the maintenance strategy and policy and communicated to all affected stakeholders.

An organization should establish a performance management system based upon service level agreements. Where a quality management system exists, the relationship between that and the performance management system should be made clear. In such cases, information and data should be capable of being entered once into either system and should be accessible from both.

9.10.2 Quality Control

Quality of construction has to be ensured during planning stage and construction stage of the facility as already emphasized by making suitable provisions for use of durable materials, proper specifications, adequate detailing with emphasis on works required to be done after construction for maintenance and upkeep. All maintenance should ideally be inspected while it is being undertaken and immediately after completion to ensure that it complies with requirements. Records and accounts rendered for maintenance work carried out should be checked for completeness and accuracy.

9.10.3 Inspections

Maintenance is intended to ensure that the facility remains fit for purpose in terms of satisfying organizational goals. This requirement is met, in part, through an effective inspection regime and forward-looking maintenance reporting.

9.10.3.1 The facility should be inspected to determine the quality of the internal environment and the condition and performance of the structure, fabric, engineering installations, fixtures and finishes. Inspection intervals should take into account the properties and anticipated service life of elements/sub-elements.

Regular inspections are actual part of the procedures for the maintenance of buildings. They are needed for a variety of purposes and each purpose requires a different approach if it is to be handled with maximum economy and efficiency. A more detailed inspection covering all parts of a building is needed to determine

what work should be included in cyclic and planned maintenance programme.

Inspections should be carried out carefully as unrecorded dangers may exist. If any area or task is suspected of being hazardous, suitable precautions should be taken.

9.10.3.2 Frequency of inspection

Inspection should be carried out at the following frequencies:

- a) *Routine* — Continuous regular observations should be undertaken by the building user as part of the occupancy of building. Feedback resulting from this type of observation should be encouraged. Consultation with occupants and other users of the facility to determine the existence of any maintenance matters that may require action and, where such work has been undertaken, measurement of users' satisfaction with the outcomes.
- b) *General* — Visual inspections of main elements should be made annually under the supervision of suitably qualified personnel at appropriate times. That informs an organization's budget for maintenance programmes and other maintenance.
- c) *Detailed* — The frequency of full inspection of the building fabric by suitably qualified personnel should not normally exceed a 5 year period. An inspection should be carried out by using a checklist made up of facility elements/sub-elements and arranged in way that supports safe working

9.10.3.3 Inspection schedule

The preparation of a specific schedule should be encouraged. Once prepared, it can be used for subsequent inspections.

9.10.3.4 Inspection of engineering services

Engineering services generally have a shorter life expectancy than building fabric and because of their dynamic function should be subjected to more frequent inspections and maintenance.

Inspection of services should be carried out for three purposes as follows:

- a) To check, if maintenance work is required,
- b) To check, if maintenance work is being adequately carried out, and
- c) For safety reasons to comply with statutory requirements and if required, with recommendations of other relevant organizations.

The frequency of inspections for purpose (a) will depend upon types of plant and system manufacturer's recommendations and subjective judgment. Frequencies for purpose (b) should be carried out on an annual basis.

9.10.3.5 Method of inspection

The limited life of building services means it is important to record their residual life so that their replacement can be budgeted for, and inspection methods should be arranged accordingly.

A checklist of items of plant to be inspected should be considered. Detailed procedure of how inspections should be carried out are necessary because a simple visual inspection is unlikely to show whether plant operating correctly and efficiently.

Inspections frequently necessitate the use of appropriate instruments by competent persons. An example of this is the inspections carried out to check compliance with statutory requirements.

When instruments are used it is important that adequate training is provided in the use of the instruments and the interpretation of the results.

9.10.3.6 Records of all inspections should be kept. Inspection report for buildings may be prepared in the format as given in Annex B.

9.10.3.7 Reporting

A maintenance report should be prepared. Information gained from inspections should be collated into two groups:

- a) The degree of urgency needed to carry out repairs; and
- b) A comparison of maintenance plans, including work of a planned preventive nature.

Attention should be paid to the requirements defined in the maintenance policy. Each item should be carefully assessed when postponing apparently non-urgent work so that it does not result in a major defect or failure over the longer term. The anticipated life of the facility, or any element of it, should be taken into account.

Anticipated failures and defects expected to lead to failure should be highlighted in reports. The resulting information should be arranged in three categories: those matters requiring immediate attention, those that can be placed into a maintenance programme and those which can be postponed but which should continue to be monitored and reviewed.

The maintenance report should address all maintenance requirements not covered by planned preventive maintenance for a period of five to ten years. Where contracts run over longer periods, maintenance plans

may extend beyond this limit. The following points should be included, as a minimum, in the maintenance report:

- 1) Location;
- 2) Name of element (for example, roof);
- 3) Name of sub-element (for example roof covering – tiling);
- 4) Existing condition (for example excellent, satisfactory, adequate, poor or unsafe);
- 5) Prioritization of the element (for example, the redecoration of a customer-facing reception area will have a higher ranking than a storage room);
- 6) Anticipated phasing of maintenance; and
- 7) Cost of maintenance.

9.11 Standard Norms for Maintenance Management

9.11.1 Labour Management

9.11.1.1 Since the types of assets and facilities, requirements and levels of maintenance vary widely from asset to asset, the same may be established between the parties concerned depending on the type of the asset and the complexities involved. Typical indicative norms for employment of workmen for day to day maintenance of buildings is given at Annex C.

9.11.1.2 Multidisciplinary skill among the workers should be encouraged.

Multidisciplinary training programmes should be organized for the workmen to impart them knowledge of various skills. After suitable tests, they should be entrusted with multidisciplinary responsibilities. This approach of multidisciplinary skill will help in improving the quality of maintenance and shall also result in speedy attendance of maintenance complaints requiring attention of two/three disciplines at a time. For details see good practice [12(2)].

9.11.1.3 Organizations should ensure that suitable expertise is available for maintenance and its management at all levels within the organization. Where this expertise is not available in an organization, external resources should be employed instead. Persons responsible for managing the maintenance of facilities, including engineering installations, should possess appropriate management ability and technical competence.

9.11.2 Recommendatory Expenditures for Maintenance

A major part of expenditure on asset/facility management is incurred on maintenance, which is determined as follows:

- a) Maintenance for day-to-day services,
- b) Annual repairs, and

c) Special repairs.

Plinth area maintenance rates, that is annual financial yardstick established for building maintenance on plinth area basis for civil, electrical/mechanical works may be taken as per existing provisions in works departments at central or state level or any other prevalent rates. Special considerations may be taken into account for hilly areas, coastal areas or other areas with severe aggressive climate.

These rates may be multiplied by approved city and year maintenance cost index factor to set the present values for particular city for particular time period. Weightages for various components may be determined based on the usage and applied to work out cost index factors for maintenance works.

NOTE — Typical weightages for building maintenance works may be:

a)	Aggregate	3.50
b)	Cement	9.00
c)	Lime	15.00
d)	Paint	25.00
e)	Sand	4.00
f)	Timber	9.00
g)	Unskilled labour	23.50
h)	Skilled labour	11.00
	Total	100.00

However, the wages shall be governed by *Minimum Wages Act*, 1948 along with the statutory provisions like PF, ESI, Bonus, etc, and other prevalent mandatory regulations of the respective States/Union Territories.

9.12 Responsibility of Occupants for Maintenance of Facilities

The provisions of **9.12.1** to **9.12.5** shall govern the responsibilities of occupants for maintenance of facilities, such as, structures, equipment and exterior property.

9.12.1 Responsibility

The owner of the premises shall maintain the structures and exterior property in compliance with requirements given in **9.12.2** to **9.12.5**, except as otherwise provided for in this Code. Occupants of a building/premises/dwelling unit are responsible for keeping in a clean, sanitary and safe condition, that part of the building/premises/dwelling unit which they occupy and control.

9.12.2 Exterior Property Areas

The owner/occupant shall maintain the following:

- a) *Vacant structures and land* — Vacant structures and premises thereof or vacant land shall be maintained in a clean, safe, secure and sanitary condition so as not to cause a blighting problem or adversely affect the

public health or safety.

- b) *Sanitation* — Exterior property and premises shall be maintained in a clean, safe and sanitary condition. The occupant shall keep that part of the exterior property that such occupant occupies or controls in a clean and sanitary condition.
- c) *Sidewalks and driveways* — Sidewalks, walkways, stairs, driveways, parking spaces and similar areas shall be kept in a proper state of repair, and maintained free from hazardous conditions.
- d) *Weeds* — Premises and exterior property shall be maintained free from weeds or plant growth in excess of height specified by Authority. Noxious weeds shall be prohibited.

Upon failure of the owner or agent having charge of a property to cut and destroy weeds after service of a notice of violation, any duly authorized employee of the Authority or contractor hired by the Authority may be authorized to enter upon the property in violation and cut and destroy the weeds growing thereon, and the costs of such removal shall be paid by the Owner or agent responsible for the property.
- e) *Exhaust vents* — Pipes, ducts, conductors, fans or blowers shall not discharge gases, steam, vapour, hot air, grease, smoke, odours or other gaseous or particulate wastes directly upon abutting or adjacent public or private property or that of another *tenant*.
- f) *Accessory structures* — All Accessory structures, including *detached* garages, fences and walls, shall be maintained structurally sound and in good repair.

9.12.3 Exterior and Interior Structure

The exterior and interior of a structure shall be maintained in good repair, structurally sound and sanitary so as not to pose a threat to the public health, safety or welfare. Following measures shall be taken:

- a) *Protective treatment* — Exterior surfaces, including but not limited to, doors, door and window frames, cornices, porches, balconies, decks and fences, shall be maintained in good condition.
- b) *Interior surfaces* — Interior surfaces, including windows and doors, shall be maintained in good, clean and sanitary condition.
- c) *Structural members* — All structural members shall be maintained free from deterioration, and shall be capable of safely supporting the

imposed dead and live loads.

- d) *Roofs and drainage* — The roof and flashing shall be sound, tight and not have defects that admit rain. Roof drainage shall be adequate to prevent dampness or deterioration in the walls or interior portion of the structure. Roof drains, gutters and downspouts shall be maintained in good repair and free from obstructions. Roof water shall not be discharged in a manner that creates a public nuisance.

9.12.4 Rubbish and Garbage

9.12.4.1 Accumulation of rubbish or garbage

Exterior property and premises, and the interior of every structure, shall be free from any accumulation of rubbish or garbage.

9.12.4.2 Disposal of rubbish and garbage

Every occupant of a structure shall dispose of all rubbish and garbage in a clean and sanitary manner by placing such rubbish, garbage in an approved rubbish/garbage disposal facility or approved containers.

9.12.4.3 Containers

The operator of every establishment producing garbage shall provide, and at all times cause to be utilized, approved leak proof containers provided with close-fitting covers for the storage of such materials until removed from the premises for disposal.

9.12.5 Pest Elimination

9.12.5.1 Infestation

Structures shall be kept free from insect and rodent infestation. Structures in which insects or rodents are found shall be promptly exterminated by approved processes that will not be injurious to human health. After pest elimination, proper precautions shall be taken to prevent re-infestation.

9.12.5.2 The responsibility of pest elimination in several cases of occupancy shall be as below:

- a) *Single owner* — The owner of any structure shall be responsible for pest elimination within the structure prior to renting or leasing the structure and the occupant of a one-family dwelling or of a single-tenant non-residential structure shall be responsible for pest elimination on the premises.
- b) *Multiple occupancy* — The owner of a structure containing two or more dwelling units, a multiple occupancy, a rooming house or a non-residential structure shall be responsible for pest elimination in the public or shared areas of the structure and exterior property.

- c) *Occupant* — The occupant of any structure shall be responsible for the continued rodent and pest-free condition of the structure.

Where the infestations are caused by defects in the structure, the owner shall be responsible for pest elimination

9.13 Common Area Maintenance

Maintenance of common areas in any building, group of buildings, should be responsibility of all those who share and use the common areas.

9.13.1 Common Areas and Equipment

The common area of a building or project includes all space contained in building premises that are not exclusive to any specific occupant(s) and which benefits, or is intended to benefit, all users/occupiers of the building, in common and without distinction.

Common area of a multiple building campus/project is proportionately loaded on to the individual segments within the overall campus. Common area of such campuses will include driveways, ramps, walkways, pavements, corridors, entrances, vestibules, stairways, atriums, refuge area, terraces (with or without common rights of access) landscapes, common toilets, loading and unloading docks, dedicated property management office, parking areas, external peripheries, façade and elevation elements and utility areas such as DG room, plant room, etc.

Common equipment will include all types of pumps for water supply, fire fighting, etc; lifts and escalators; firefighting system; HVAC plant and equipment; E&M equipment like electric panels, DG sets, transformers, lightning protection system, earthing system, etc.

9.13.2 Maintenance of Common Areas

One way to arrange for funds to carry out this function is to levy a common area maintenance (CAM) charge on all the users. The value of CAM to be charged can be decided by the owner or it can be collectively decided by the users. Normally, CAM is charged on pro-rate basis, that is, on the ratio of area in actual occupation of each user *vis-a-vis* the total area. While computing the CAM charges it is normal practice to include expense incurred towards providing common facilities to all occupiers of a building/facility like cost of housekeeping services; energy consumption of fixtures and equipment provided for the common areas, annual maintenance contracts, if any; of equipment, spares and consumables and charges for property management services, all expenses towards maintaining regulatory and statutory compliance as applicable to

the building or the project, insurance of building and equipment, sinking fund and expenditure incurred on annual maintenance of common areas, etc.

9.14 Maintenance from Accessibility Consideration

All maintenance and refurbishment in public buildings and built environment shall take into account improving accessibility for persons with disabilities and care taken that accessible design features are properly maintained during maintenance activities (*see B-25* of Part 3 ‘Development Control Rules and General Building Requirements’ of the Code). Periodic access audits shall be carried out at least once in three years to ensure that the requisite accessible features as per Part 3 ‘Development Control Rules and General Building Requirements’ of the Code are provided in the building and its built environment and maintained in good condition on an ongoing basis.

10 BUILDING FABRIC MAINTENANCE

10.1 This constitutes maintenance of elements and components of a building other than furniture and services installations.

10.2 Prevention of Cracks, Repairs, Retrofitting and Seismic Strengthening of Buildings

Cracks in buildings are of common occurrence. A building component develops cracks whenever stress in the component exceeds its strength. Stress in a building component can be caused by externally applied forces, such as dead, imposed, wind or seismic loads, or foundation settlement or it can be induced internally due to thermal movements, moisture, chemical action, etc. The buildings affected by earthquake may suffer both non-structural and structural damages. Non-structural repairs may cover the damages to civil and electrical items including the services in the building. Repairs to non-structural components need to be taken up after the structural repairs are carried out. Care should be taken about the connection details of architectural components to the main structural components to ensure their stability. The main purpose of the seismic strengthening is to upgrade the seismic resistance of a damaged building while repairing so that it becomes safer under future earthquake occurrences.

10.2.1 Prevention of cracks, repair work, seismic strengthening and retrofitting of an existing building shall be done in accordance with Part 7 ‘Construction Management, Practices and Safety’ of the Code.

10.3 While demolishing a damaged building or existing unsafe building, safety precautions as given in Part 7 ‘Construction Management, Practices and Safety’ of the Code shall be observed.

11 MAINTENANCE OF PLUMBING AND DRAINAGE SYSTEMS

11.1 General

Plumbing fixtures shall be properly installed and maintained in working order, and shall be kept free from obstructions, leaks and defects and be capable of performing the function for which such plumbing fixtures are designed. Plumbing fixtures shall be maintained in a safe, sanitary and functional condition. Where it is found that a plumbing system in a structure constitutes a hazard to the occupants or the structure by reason of inadequate service, inadequate venting, cross connection, back-siphonage, improper installation, deterioration or damage or for similar reasons, the same should be attended to immediately.

11.2 Plumbing System

Plumbing system is a system installed in a building for the distribution and use of potable water and the removal of waterborne wastes. It covers the system that operates toilets, sinks, showers, bathtubs, etc, as also laundry facilities in buildings for washer, utility sinks, and drains that may be installed.

11.3 Drainage System

Water outputs in a building include,

- a) storm water,
- b) grey water,
- c) black water, runoff, and
- d) evaporation and leaks.

These are discussed in **11.3.1** to **11.3.4**.

11.3.1 Storm Water

Storm water should be reclaimed to a great extent though properly designed rainwater harvesting. Excess storm water needs to be drained off through properly designed drainage system. Outlet for it shall be identified and checked for its carrying capacity and final disposal so as to avoid inundation and unhygienic conditions.

11.3.2 Grey Water

It is the waste water collected from indoor sources, other than toilets, such as showers and hand basins, washing machines and requires treatment such as screening, oil and grease removal (if kitchen wastewater is also included in the source), filtration and disinfection. Grey water comprises 50-80 percent of residential wastewater. If grey water is filtered properly, reusing it for irrigation and further conveyance is safe from a health perspective.

11.3.3 Black Water

It is the discharge from the toilet and contains significant

nutrient concentrations. The microbial contamination associated with black water demands it to be treated to a very high level, especially with respect to disinfection.

11.3.4 Evaporation and Leaks

Evaporation can account for a significant water loss in building systems that rely on evaporative cooling towers. Leaks can also account for a significant quantity of water use if they are not detected and corrected in a timely manner. In taking a strategic approach to improving water performance, all inputs, uses, and outputs should be considered.

11.4 Plumbing and drainage system shall be designed in accordance with Part 9 'Plumbing Services, Section 1 Water Supply and Section 2 Drainage and Sanitation' of the Code. Good practices as given in these Sections of the Code attempt to minimise risk by specifying technical standards of design, materials and workmanship.

11.5 Only licensed/registered plumbers with specified qualifications should be permitted to carry out work of plumbing and installations. Such works shall be inspected by competent person to check their adequacy and functionality. For guidelines for registration of plumbers including the minimum standards for qualifications for the grant of licences, reference may be made to good practice [12(3)].

No person should be permitted to construct, install, extend or materially alter any plumbing system without making formal application to, and receiving formal approval from, the concerned authority. Except where the authority shall agree in writing to other dispositions, only a licensed plumber shall be authorized to be responsible for the construction, repair, alteration or removal of pipes, valves, drains or other appurtenances of any drinking-water supply or drainage system (including storm drainage discharging into a public sewer or watercourse) in any building or on any land. Only a licensed plumber may make a connection to a public water main or to a public sewer, and he shall be responsible for giving notice to the water and sewerage authorities of the intention of making such connection for satisfying any requirements of those bodies.

11.6 Restoration and Recycling of Waste Water

All wastewater can potentially be recycled within a building system. Wastewater exiting the building under grey water or black water should be recycled in various possible ways.

11.7 Rain Water Harvesting

It is essential to provide rain water harvesting or storage systems to capture the runoff from the roof surfaces. For details, reference shall be made in Part 9 'Plumbing Services, Section 2 Drainage and Sanitation' of the Code.

11.8 Common Problems

The maintenance of water supply and sanitary system in buildings requires thorough knowledge about the design, specifications and the materials used within the building and for external connections. If the defects are not attended timely, these may result in unhygienic conditions and ultimate structural failures too. Availability of as-built drawings for services is of great help in taking up repair and restoration works.

The faults in these services occur due to defective system and misuse. The common problems in water supply and sanitary system are as follows:

- a) Leakage in internal pipes;
- b) Blocked drains and leaking joints;
- c) Damaged floor drains;
- d) Overflowing cisterns;
- e) Blocked waste pipes;
- f) Defective or improperly fixed fittings;
- g) Inadequate pressure;
- h) Maintenance of appliances;
- j) Noise in plumbing system;
- k) Odour in piping system;
- m) Seepage through floor joints of wet areas;
- n) Heading up of water on terraces; and
- p) Damaged or cracked appliances.

Early detection of leakage seepage is possible with use of thermal cameras which are available and can detect the early signs of leakages, etc, and can actually photograph the same showing location and its intensity.

As steady drip which comes out drop by drop can waste as much as 9 000 litre of water every three months, use of good fittings and urgent attendance to leakages/ drippings can hardly be overemphasized.

11.9 Precautionary Measures

- a) *Avoid chemical drain-clearing products* — Clogged drains are the most common home plumbing problem. Chemical products used to clear clogged drains, may harm the drainage system. They can actually erode cast-iron drain pipes, and because they typically don't remove the entire clog, the problem is likely to recur, resulting in their repeated use. Drain should therefore be cleaned by removing chunk of hair and grease by using flexible drain cleaning devices (snake).
- b) *Prevent future clogging* — Clogs aren't just nuisances. Backed-up water puts added pressure on wastepipes, stressing them and shortening their lifespan. Therefore, avoid plug-ups by watching what goes down the

drains. Keep food scraps out of kitchen drains, hair out of bathroom drains, and anything but sewage and toilet paper out of toilets.

- c) Install screens over drains in showers and tubs, and pull out hair every few weeks to prevent build-ups. Scrape food into the trash before doing dishes, even if there is a disposal and never put liquid grease down the drain; pour it into a sealable container to put in the garbage after it cools.
- d) *Reduce the pressure* — High water pressure stresses pipes, and increases the likelihood of a leak. It drastically reduces the life of plumbing system. It makes pipe joints, faucets, and appliance valves work harder.
- e) *Soften the water* — If the water has a high mineral content, known as hard water; it can shorten plumbing's lifespan. A white build up on showerheads and faucets is a tell-tale sign of hard water. To effectively deal with hard water install a water softener.
- f) *Keep sewer lines or septic tank clear* — Snake main sewage cleanout every few years to remove messy sewage backups. Always detect and fix problems quickly. Even small leaks can make pipes corrode more quickly, and cause significant water damage. Water test and/or smoke tests on the drainage of the plumbing system should be carried out before accepting the system and allowing final finishing works.

11.10 Maintenance of Plumbing and Drainage Systems

11.10.1 General

Proper maintenance ensures that all fittings and fixtures are kept in acceptable working condition so that their utility is not sacrificed.

Even little leaks in plumbing can lead to big problems. It is therefore necessary to be alert to signs of impending plumbing failures, such as, leaking faucets, damp cabinets, leaking toilets or dripping refrigerators; all signal problems that need prompt attention. Problems should be repaired early. A leaking faucet isn't just annoying; the moisture it releases puts wear on sink fixtures and can encourage the growth of mold and mildew. A licensed plumber should be called to get repairs done in a professional manner.

Design of various areas has to be such that all appliances and areas needing frequent maintenance are easily approachable and adequate working space is available to maintenance personnel.

Shaft shall be of adequate size to allow workmen to

carry out their functions properly. Working platforms and easy access to the shafts and working platforms should be ensured. Specific provisions are required to be made for maintaining services in multistoried buildings.

Checking of roofs, drains, traps on regular basis should be carried out as part of preventive maintenance to ensure that they are clean and functional. Users and cleaning personnel have to be educated not to throw solid waste into WC's, traps and drainage system.

It is good practice to lay-down a periodical drill for doing some of the maintenance works required to be done on regular basis such as white washing, painting, drain de-silting, roads re-carpeting, cleaning of traps, manholes, cleaning of tanks, etc. A small inventory of items which are often required should be kept in store for immediate use.

For effective maintenance it is necessary that the buildings are inspected on regular basis and corrective measures taken as per the outcome of inspection. Special attention is required to be paid to inspection of storm water drainage works, roofs before monsoon. This can help in preventing problem from getting worse.

Checking of roofs, drains, traps on regular basis should be carried out as part of preventive maintenance to ensure that they are clean and functional. Users and cleaning personnel have to be educated not to throw solid waste into WCs, traps and drainage system.

Special attention is to be paid to inspection of storm water drainage works, roofs before monsoon.

All fittings and fixtures should be checked regularly. For monitoring on an annual and bi-annual basis, a check list will be helpful for checking plumbing problems or potential plumbing problems.

11.10.2 Maintenance of Plumbing Systems

11.10.2.1 All water mains communication pipes, service pipes and pipes used for distribution of water for domestic purposes shall be thoroughly and efficiently disinfected before being taken into use and also after every major repair. The method of disinfection shall be subject to the approval of the Authority. The pipes shall also be periodically cleaned at intervals, depending upon the quality of water, communication pipes and the storage cisterns shall be thoroughly cleaned at least once every year in order to remove any suspended impurities that may have settled in the pipes or the tanks.

11.10.2.2 Storage tanks shall be regularly inspected and shall be cleaned out periodically, if necessary. Tanks showing signs of corrosion shall be emptied, thoroughly wire brushed to remove loose material (but not

scraped), cleaned and coated with suitable anti-corrosive material not liable to impart taste or odour or otherwise contaminate the water. Before cleaning the cistern, the outlets shall be plugged to prevent debris from entering the pipes. Tanks shall be examined for metal wastage and water tightness after cleaning.

11.10.2.3 Record drawings showing pipe layout and valve positions shall be kept up to date and inspection undertaken to ensure that any maintenance work has not introduced cross-connections or any other undesirable feature. Any addition or alterations to the systems shall be duly recorded from time-to-time.

11.10.2.4 Any temporary attachment fixed to a tap or outlet shall never be left in such a position that back-siphonage of polluted water may occur into the supply system.

11.10.2.5 All valves shall periodically be operated to maintain free movement of the working parts.

11.10.2.6 All taps and ball valves shall be watertight, glands shall be made good, washers shall be replaced and the mechanism of spring operated taps and ball valves shall be repaired, where required.

11.10.2.7 All overflow pipes shall be examined and kept free from obstructions.

11.10.2.8 The electrical installation shall be checked for earth continuity and any defects or deficiencies corrected in the case of hot water supply installations.

11.10.3 Maintenance of Drainage Systems

11.10.3.1 General

Domestic drainage system shall be inspected at regular intervals. The system shall be thoroughly cleaned out at the same time and any defects discovered shall be made good.

11.10.3.2 Cleaning of drainage system

- a) Sewer maintenance crews, when entering a deep manhole or sewer where dangerous gas or oxygen deficiencies may be present, shall take safety precautions required and follow the following procedures:
 - 1) Allow no smoking or open flames and guard against sparks.
 - 2) Erect warning signs.
 - 3) Use only safety gas-proof, electric lighting equipment.
 - 4) Test the atmosphere for noxious gases and oxygen deficiencies (presence of hydrogen sulphide is detected using lead acetate paper and that of oxygen by safety lamps).
 - 5) If the atmosphere is normal, workmen

- may enter with a safety belt attached and with two men available at the top. For extended jobs, the gas tests shall be repeated at frequent intervals, depending on circumstances.
- 6) If oxygen deficiency or noxious gas is found, the structure shall be ventilated with pure air by keeping open at least one manhole cover each on upstream and downstream side for quick exit of toxic gases or by artificial means. The gas tests shall be repeated and the atmosphere cleared before entering. Adequate ventilation shall be maintained during this work and the tests repeated frequently.
 - 7) If the gas or oxygen deficiency is present and it is not practicable to ventilate adequately before workers enter, a hose mask shall be worn and extreme care taken to avoid all sources of ignition. Workers shall be taught how to use the hose equipment. In these cases, they shall always use permissible safety lights (not ordinary flash lights), rubber boots or non-sparking shoes and non-sparking tools;
 - 8) Workmen descending a manhole shaft to inspect or clean sewers shall try each ladder step or rung carefully before putting the full weight on it to guard against insecure fastening due to corrosion of the rung at the manhole wall. When work is going on in deep sewers, at least two men shall be available for lifting workers from the manhole in the event of serious injury; and
 - 9) Portable air blowers, for ventilating manhole, are recommended for all tank, pit or manhole work where there is a question as to the presence of noxious gas, vapours or oxygen deficiency. The motors for these shall be of weather proof and flame-proof types; compression ignition diesel type (without sparking plug) may be used. When used, these shall be placed not less than 2 m away from the opening and on the leeward side protected from wind, so that they will not serve as a source of ignition for any inflammable gas which may be present. Provision should be made for ventilation and it should be of the forced type which can be provided by a blower located at ground level with suitable flexible ducting to displace out air from the manhole.
- b) The following operations shall be carried out during periodical cleaning of a drainage system:
 - 1) The covers of inspection chambers and manholes shall be removed and the side benching and channels scrubbed;
 - 2) The interceptive trap, if fitted, shall be adequately cleaned and flushed with clean water. Care shall be taken to see that the stopper in the rodding arm is securely replaced;
 - 3) All lengths of main and branch drains shall be rodded by means of drain rods and a suitable rubber or leather plunger. After rodding, the drains shall be thoroughly flushed with clean water. Any obstruction found shall be removed with suitable drain cleaning tools and the system thereafter shall be flushed with clean water;
 - 4) All subsoil drains shall be periodically examined for obstruction at the open joints due to the roots of plants or other growths;
 - 5) The covers of access plates to all gullies shall be removed and the traps plunged and flushed out thoroughly with clean water. Care shall be taken not to flush the gully deposit into the system;
 - 6) Any defects revealed as a result of inspection or test shall be made good;
 - 7) The covers or inspection chambers and gullies shall be replaced, bedding them in suitable grease or other materials; and
 - 8) Painting of ladders/rings in deep manholes and external painting of manhole covers shall be done with approved paints.
- 11.10.3.3 Operation and maintenance of sewage treatment plant (STP)**
- a) *Operational checks for STP* — More and more campuses are now being served by STPs for treatment of waste water and reusing it for various purposes. Maintenance of STPs and their operation is an essential activity for proper functioning of facilities where such plants are provided.

The methods of checking operational aspects of the STPs are given in Annex D.
 - b) *Operation and maintenance considerations*
 - 1) Typically, in small plants, the filter press may be sized for a single batch operation

- per day. In large plants, three batches per day, one per shift, is the norm.
- 2) Fresh sludge (not more than a day old), kept fully aerated and mixed (agitated).
 - 3) Dewaterers easily in the filter press. Hence, sludge shall not be stored in the holding tank for longer durations.
 - 4) The desired quantity of polymer needs to be added 15 - 30 min before the dewatering operation. Filter press operation is carried out over 3 - 4 h, or when filtration ceases.
 - 5) After every dewatering operation, the filter clothes shall be thoroughly cleaned, so that clogging in the pores of the woven polypropylene filter fabric is avoided. Periodic cleaning of filter cloth with hypo solution will also prolong the life of cloth.
 - 6) When the filtration process becomes excessively slow, it is time to replace the filter cloth with a fresh set.
 - 7) Normal maintenance as prescribed by the manufacturer may be practiced for the high pressure helical screw pump. Care shall be taken not to damage the rubber stator of the screw pump by dry running of the pump. It is generally preferable to locate the pumps such that positive suction is enabled.
- c) *Miscellaneous considerations*
- 1) Genset backup power to run the entire STP in case the mains electricity line fails.
 - 2) Adequate illumination in STP if in a room, or basement.
 - 3) Totally covered, underground STPs are neither operator-friendly, nor maintenance-friendly.
 - 4) Adequate exhaust and ventilation system to be provided for operator comfort, health and hygiene.
 - 5) Without proper exhaust/ ventilation in enclosed spaces, carbon dioxide accumulates, gets converted to carbonic acid and corrodes metallic parts in the STP. Carbonic acid also depresses pH of the wastewater, thus affecting treatment performance.
 - 6) Provide safe and comfortable access to all units in STP for monitoring, operation, and maintenance.
 - 7) Prepare and maintain a standard operating procedure for the STP and train all operators to follow those procedures.
- 8) Prepare and maintain an operating log book for all activities in the STP.
 - 9) Prepare and maintain a mechanical checklist for routine preventive maintenance.
 - 10) Prepare and maintain a history sheet for each critical equipment in the STP.
 - 11) Prepare and maintain a chemicals/ consumables stock register.
 - 12) Periodically check and validate all log books, checklists, etc.
 - 13) Provide a water meter at the outlet of each type of water treatment system for respective uses to monitor average daily throughput of the STP.
 - 14) *Ventilation system* — Required air changes should be provided to ensure good ventilation. The air change is calculated based on the open/vacant head space of the underground/ basement room. There shall be a fresh air fan (forced draft) and an exhaust fan (induced draft), with two separate ducting systems.
 - 15) If the induced draft fan is designed for a slightly higher capacity than the fresh air fan, then the room will always be under a slight negative pressure, and gases will not escape the room as fugitive emissions.
- d) *Abnormal conditions*
- 1) *Excess flow to STP* — At times due to malfunction of the flushing systems in the toilets, excessive inflow to the STP may be encountered. Similar is the situation during heavy rainfall. This upsets normal operation by flooding the collection tank; submerging the pumps and causing excessive flow to aeration tank. The remedies and recommended operational procedures for these situations are as follows:
 - 2) *Remedy*
 - i) Make all toilets' flushing systems fail proof.
 - ii) Raise manhole levels and make covers water tight in the conveyance system.
 - iii) Replace existing lift pumps by submersible pumps.
 - 3) *Operation*
 - i) Keep collection tank near empty at all times in order to accommodate

sudden excessive inflows.

- ii) If level continues to rise to near pump level, start both pumps.
 - iii) If level continues to rise, switch off both pumps and activate standby external portable pump to save the duty pumps.
- 4) *MLSS washout due to excess flow* — Consequent to high inflow conditions due to reasons cited in (1) above, mixed liquor suspended solids (MLSS) washout from the system may occur. In order to quickly put the system back to normal, it is recommended that controlled transfer of MLSS from the digester tank (to a maximum extent of 50 ml/l of MLSS per day) to the aeration tank be done so that the design level of MLSS is reached within 4-5 days of washout. For this purpose, the aerobic digester tank should be operated at near full conditions.
- 5) *pH variations in inflow* — Although pH variations in domestic sewage are not a cause for concern, it is possible that due to accidental spillage/ excessive usage of cleaning chemicals in the toilets may result in pH variations.

11.11 Attention to Wet Areas

In case of wet areas, planning for good maintenance has to be done even before execution. Bathroom, kitchen, water closet and to a lesser extent *Verandah*, balconies and sunshades may be termed as wet areas of a buildings which are more vulnerable to water due to their functional requirements. These wet areas are one of the main source of leakage and dampness in a building which leads to unhygienic conditions affecting badly the health and comfort of the inhabitants and seriously deteriorating the stability of the building. The causes of dampness and leakage may be due to defective design, sub-standard material, improper execution and incorrect usage by the occupant. For provisions on methods to be employed in a building under construction for preventing dampness and leakage arising out of the wet areas, reference shall be made to the good practice [12(4)].

Problem of leakage and dampness in building already in use require different considered approach in the analysis of the cause and remedial measures.

11.12 Selection, installation and maintenance of sanitary appliances shall be done in accordance with good practice [12(5)].

12 MAINTENANCE OF HEATING, VENTILATION AND AIR CONDITIONING (HVAC) SYSTEMS

12.1 The aspects of operation and maintenance of HVAC services and guidelines on good operating practices, maintenance requirement, its frequency, etc, in order to improve the performance of the equipment, reduce failure risk, increase life and effective use of the equipment, and save on energy consumption are covered hereunder. HVAC services include,

- a) individual units;
- b) plants and pumps;
- c) ducts, grills and other air conveyance systems;
- d) smoke extraction system; and
- e) fire dampers.

For effective management of the asset, component wise operation and maintenance protocol need to be observed. It is necessary to understand basic operating logic that can be implemented manually, or through a building management system.

12.2 Selection of Equipment/Systems

Selection of equipment/systems should be made after careful consideration keeping in view the specific requirements of the facility and after duly computing the heat loads and other relevant factors. At the stage of handing over of the HVAC system by the vendor, the facility manager shall check the system running with internal loads, and also check that uniform temperature, within allowable tolerances, is being maintained throughout the air conditioned area.

12.3 The HVAC vendor shall handover the system with complete air and water balancing, along with a commissioning report. There are various types of HVAC systems available and these are selected, depending upon the intended use and economic viability. Whichever be the system installed, the same has to be maintained properly to obtain optimum output.

12.4 Guidelines on maintaining of equipment issued by the manufacturer shall be followed and regular servicing shall be got done through trained/accredited service providers to ensure proper results.

12.5 Operation of the system should be done by first switching on the indoor unit fan, and then the condensing unit. Normally most modern packaged and ductable split units have an inbuilt sequencing and only an on/off switch needs to be operated. In order to save energy consumption and to prevent discomfort to occupants, it is advisable to set the temperature in accordance with Part 8 'Building Services, Section 3 Air Conditioning, Heating and Mechanical Ventilation' of the Code. It is advisable to switch on the HVAC

units a little before facility/office starts working to lower the indoor temperature for achieving comfort levels.

12.6 Regular cleaning of filters is the most important maintenance aspect for HVAC systems. A schedule for air filter cleaning shall be established and followed and a log should be maintained for same. Frequency of cleaning of filters should be determined keeping in view the usage, location and recommendation of the manufacturers.

12.7 Cleaning the condenser coil for air conditioning (AC) units and checking all operating pressures to ensure that there are no gas leaks and that the system is working properly should be got done through skilled technicians at regular intervals to ensure proper working of all systems.

12.8 Maintaining and operating of central HVAC plant should be done as per guidelines of the manufacturers and suppliers as it has a number of components. The components of a central air conditioning system include, chillers, pumps, air handling units, chilled water pipe systems, control valves, electrical systems, ducts, cooling towers and water softening systems. All these components are important and shall be maintained properly and as per protocol prescribed by the manufacturer/design consultant.

12.8.1 *Operation of Central AC Plants*

12.8.1.1 It is important to follow laid down sequence either manually, or through BMS - first, switch on the air handling units (AHUs), followed by chilled water pumps, followed by cooling tower fan, followed by condenser water pumps, followed by chiller. Following measures shall be adopted:

- a) The chilled water temperature shall be set as per design set point. However, the set point can be increased in winter or during night operation by 1°C to 3°C, to save energy. This set point change may be done when loads are less, during winter/night, especially in non-monsoon months as per the advice of the HVAC system designer. Room thermostats for common areas may be set at universal comfort condition of 24°C, and individual area thermostats at temperature between 24°C and 25.5°C, depending upon individual comfort.
- b) All AHU should be maintained properly to ensure that there is no loss of energy because of clogged filters. The basic maintenance protocol is similar (in terms of filter cleaning) as a ductable split. In addition, a regular maintenance visit by HVAC vendor is recommended, to check strainer, pressure drops, etc.

- c) All pumps shall be checked regularly to look for leakages, current consumption, temperature and operating pressure, etc.
- d) Cooling tower sump water should be checked monthly and laboratory analysis of the water shall be carried out to ensure that the total dissolved solid (TDS) level is below 500 ppm (or as per chiller supplier's recommendation). Blow down or bleed off from the sump, with continuous replenishment of soft water, to maintain TDS levels is recommended. Where possible, the bleed off from sump of cooling tower may be led to water softening plant for treatment and recirculation.
- e) Cleaning of air-conveyance system such as ducting, grills, diffusers, is important to ensure that desired level of hygiene is maintained. This is most important in hospitals and public places.

12.8.1.2 The most important aspect is to continuously monitor the plant. It is advisable that this monitoring be done through a BMS and continuously seek refinement of the programmed logic, till the user is satisfied. A BMS does not substitute a scheduled maintenance operation but it helps to check and document sensor readings making it perform better and improve the life of the system. Readings through this system can be evaluated every quarter, to obtain annually a calibration of components like flow meters and gauges. The BMS can also provide measurement and verification of plant capacity and efficiency. It is also recommended to do a quarterly random check of few sample reports, and compare with physical readings. In addition, the BMS shall be interlinked with all safety and alarms, such as fire and access control. The BMS shall maintain a log of basic parameters like operating hours of each major component of HVAC plant, with records of in/out temperatures, and operating pressures. These logs shall be scrutinized at least once in a month by the operations team, to check for anomalies if any, in order to detect adverse operating conditions, and prevent failures.

12.9 *Periodicity/Frequency of Servicing*

Depending upon the type of facility, type and specification of equipment installed, usage and other operational and financial constraints, the optimum frequency of carrying out servicing should be determined. A regular record of all maintenance and service operations shall be maintained and periodically reviewed.

Daily logs of operation with timings, and readings of important parameters should be maintained. It should be ensured that logs are always up to date in real time.

Back log being filled later shall be prohibited.

13.10 In addition to above, the requirements for operation and maintenance of HVAC systems as laid down in Part 8 'Building Services, Section 3 Air conditioning, Heating and Mechanical Ventilation' of the Code shall also be complied with.

13 MAINTENANCE OF ELECTRICAL INSTALLATIONS

13.1 Electrical installations in building have to be installed and constantly maintained in proper working condition to ensure efficient use of electricity including safety from fire and shock. Electrical system maintenance is very important as it also helps in ensuring smooth operation of all plants and equipment. The coverage is limited to maintenance of internal electrical installations starting from receiving of electric supply within premises. It covers HV panels, HV switches, transformers, LV panels, floor panels, earthing, internal electrical distribution systems, light fixtures/switches/MCBs, lightning arrestors, street lighting systems, facade lighting and transformers.

13.2 Planning of Electrical Maintenance Work

The authorized person shall have complete knowledge of the electrical appliances to be worked upon, to ensure safety. Repetitive nature of jobs require lesser pre-planning, whereas infrequent nature of jobs may need careful planning.

Planned routine maintenance will facilitate continued safe and acceptable operation of an electrical system with a minimum risk of breakdown and consequent interruption of supply. As far as the electrical equipment/installations are concerned, for the interval between the maintenance required, recommendation of the manufacturer should be followed. The manufacturer should be requested to specify minimum maintenance frequency under specified conditions. These intervals depend greatly upon the design of the equipment, the duty that it is called onto perform and the environment in which it is situated. At least annual health check up of all E&M equipment shall be carried out. Following two types of maintenance are envisaged:

- a) *Routine maintenance* — Routine maintenance of the electrical equipment goes along with the regular inspections of the other equipment. Inspections shall reveal the undue damage and excessive wear to the various components. Examination of the equipment shall reveal need for conditioning of the contact system, lubrication and adjustment of the other relevant mechanisms.
- b) *Post fault maintenance* — When there is a

breakdown in the system and certain parts are identified for the replacement and then the maintenance/repair of the defective part away from the operating environment is covered under post fault maintenance.

13.3 Uninterrupted and hazard free functioning of the electrical installations are the basic requirements of maintenance. The equipment should be restored to correct working conditions. Special attention should be paid to the items and settings that may have been disturbed during the operational phase. Loose and extraneous equipment or wiring give rise to potential safety hazards. All covers and locking arrangements should be properly checked and secured to achieve original degree of protection.

13.3.1 Following maintenance procedures shall be adopted:

- a) All transformers shall be provided with a linked switch with fuse or circuit breaker of adequate capacity. These should be checked annually to ensure the safety of the transformers. Where oil type transformers are used, timely de-hydration of oil and topping up shall be done to ensure proper functioning.
- b) Regular servicing of all circuit breakers shall be ensured so that they function properly and provide desired safety.
- c) The supply of energy of each motor or a group of motors or other equipment/apparatus meant for operating one particular machine should be controlled by a suitable linked switch, or a circuit breaker, or an emergency tripping device with manual reset of requisite capacity, placed in such a position as to be adjacent to the motor or a group of motors; or other apparatus readily accessible to and easily operated by the person in charge and so connected in the circuit that by its means all supply of energy can be cut off from the motor or group of motors or apparatus from any regulating switch, resistance of other device associated therewith. It should be ensured that at time of working on these equipment, this switch remains in off position to ensure safety of workers.
- d) All insulating materials should be chosen with special regard to the circumstances of its proposed use ensuring that their mechanical strength is sufficient for its purpose and so far as is practicable of such a character or so protected as to maintain adequately its insulating property under all working conditions in respect of temperature and moisture.

- e) Adequate precautions shall be taken to ensure that no live parts are so exposed as to cause danger.
- f) Where energy is being supplied, transformed, converted or used, the consumer, supplier or the owner of the concerned installation should be responsible for the continuous observance of the provisions in respect of his installations.
- g) List of authorized person should be displayed on HV, LV, lift machine room because of likelihood of lots of hazards in these areas. Proper signage shall be displayed to discourage unauthorized personnel in these areas.
- h) Lock out and tag out (LOTO) processes:
 - 1) Inform all affected employees that more than one group/person is doing servicing /maintenance on same equipment/ location.
 - 2) Have person in charge for each group for locked out and tag out to perform the servicing or maintenance.
 - 3) Authorized employee has to identify the type and magnitude of the energy and inform all concerned.
 - 4) Person in-charge has to fill the declaration form owning his overall responsibility to place lock out/tag out.
 - 5) The person in-charge has to impart the necessary information to each person of the various sources of hazardous energy and the method of isolation.
 - 6) Equipment is to be disconnected from the energy source.
 - 7) Each person in-charge has to provide his/her lock, on behalf of the group and tag out.
 - 8) Key of the lock shall be kept with the person executing the job.

13.3.2 Maintenance of UPS/Inverter

Following maintenance procedures shall be adopted:

- a) UPS/Inverter for emergency lighting system backup shall be checked at regular intervals.
- b) Life safety systems; emergency lighting and fire alarm systems that are required to be provided with an emergency power supply from batteries shall be checked by switching off power supply to see their operations. A log book for backup time shall be maintained.

13.3.3 Maintenance of Battery

Storage batteries are provided for various functions such as for UPS/Invertors, DG sets, lift ARD, etc.

Wherever batteries are installed, two flame proof exhaust fans shall be provided in battery room (one should run on fire indication and timer as well) to exhaust gases (during battery charging) and smoke (in case of fire) from battery room. Flame proof light fixtures will only be used in battery room. Lift automatic rescue device (ARD) and other critical system battery should be replaced after every 18 months to avoid ARD failure. All fittings and fixtures in battery room shall be flame proof.

Appropriate gas detectors can be installed in battery rooms to detect and warn about buildup of harmful gasses. These detectors should be regularly monitored and inspected to ensure proper functioning

13.3.3.1 Standard operating procedures for maintenance of dry cell battery

- a) Check the batteries as per the schedule and make record.
- b) Clean the battery terminal on regular basis.
- c) Avoid charging of batteries on boost mode. Float mode of charging is best way to increase the life of the battery.
- d) Check the charger for auto cut after charging. Overcharging is very harmful for the batteries.
- e) Check for deposition of any sulphate on battery terminal, if found, clean with hot water and apply petroleum jelly.
- f) Avoid high temperature in battery room.
- g) For the performance of the batteries, voltage shall be checked on each battery terminal after determination of individual battery terminal.
- h) Replace the battery, if voltage is found to be less than the specified voltage.

13.3.3.2 Standard operating procedures for maintenance of lead acid battery

- a) Do the routine checks of lead acid batteries.
- b) Check the distilled water level in the batteries. Never overfill the water.
- c) Always keep the chargers in auto charge mode. Avoid boost charging.
- d) Never add new electrolyte in the batteries.
- e) Never add raw water to the batteries, it may contain minerals that can contaminate the electrolyte.
- f) Check for the sulphation.
- g) Check all the cells with the help of cell tester.
- h) Check the gravity of the batteries on regular basis.
- j) Battery terminals to be checked and tightened.
- k) Maintain the cross ventilation in battery room.

13.3.4 Earth Pits and Earthing Installations

Earth pit should not be located near pavements, roads and near the building and minimum distance from the wall to the pit should not be less 1.5 m. Earth wires running along various sub-circuit shall terminate at the main distribution panel. Resistance of earthing pits shall be checked at least once in a year. Earthing pit record shall be maintained.

13.3.5 DG Set and its Auxiliary Operation

DG sets should be maintained and operated only by trained technicians. Adequate stock of diesel should be maintained to ensure that the DG sets are able to provide backup power for duration of mains failure. If more than one DG set is installed then where possible DG sets should be synchronized to ensure that optimum power output is received. It should be ensured that DG sets are not operated beyond their designated power rating and also not below desired power rating. In this regard recommendation of DG set manufacturers shall be followed.

Regular checks shall be got carried out from authorized technicians/service providers. Adequate safety precautions shall be taken while operating the DG sets. All exhaust systems shall be checked at regular intervals to ensure that DG exhaust does not get blocked or is allowed to pollute sensitive areas.

13.3.6 Emergency Lighting

13.3.6.1 Just like fire extinguishers, smoke alarms and other life safety equipment, emergency lighting fixture is required in commercial, industrial and institutional buildings for times when emergency situations arise, so that people are able to find their way out of a building. These are often referred to as egress lighting.

Modern emergency lighting is installed in virtually every commercial and high occupancy residential building. The lights consist of one or more parabolic aluminized reflector (PAR 36) sealed beams or wedge base lamps. All units have a reflector to focus and intensify the light they produce. This can either be in the form of a plastic cover over the fixture, or a reflector placed behind the light source. Most individual light sources can be rotated and aimed for where light is needed most in an emergency, such as towards fire exits. Advance feature fixtures usually have a test button which temporarily overrides the unit, and causes it to switch on the lights and operate from battery power even if the main power is still on. Modern systems are operated with relatively low voltage, usually from 6-12 V. This reduces both the size of the batteries required as also the load on the circuit to which the emergency light is wired. Batteries are commonly made of lead-calcium/maintenance free and can last for 10

years or more on continuous charge. Fire safety aspects may require a minimum of 90 min on battery power during a power outage along the path of egress.

To indicate that a power outage has occurred, some models of emergency lights can only be shut off manually after they have been activated, even if the main building power has come back on. The system will stay lit until the reset button on the side of the unit is pressed. As there are strict requirements to provide required lighting along the path of egress, emergency lighting should be selected carefully to ensure compliance thereof as per this Code.

An emergency lighting installation may be either a central standby source such as a bank of lead acid batteries and control gear/chargers supplying slave fittings throughout the building, or may be constructed using self-contained emergency fittings which incorporate the lamp, battery, charger and control equipment. Self-contained emergency lighting fittings may operate in 'maintained' mode (Illuminated all the time or controlled by a switch) or 'non-maintained' mode (Illuminated only when the normal supply fails).

Another popular method involves battery backup ballasts that are installed within or adjacent to existing lighting fixtures. Upon sensing power loss, the ballasts switch into emergency mode turning the existing lighting into emergency lighting without the need of wiring separate circuits or external wall mounts.

For remote mounted emergency lighting, wiring from the central power source to emergency luminaries should be kept segregated from other wiring, and constructed in fire resistant cabling and wiring systems. Minimum illumination levels in escape routes and open areas should be kept as per the requirements of this Code. When non-maintained fittings are used, they shall be supplied from the same final circuit as the main lighting circuit in the area.

Emergency lighting fixtures/exit lights can use non-electrical photo luminescent lighting technology with advantage to save energy.

Smoke injures or kills more people than heat from the fire, hence the electrical emergency lighting should be designed and properly marked to effectively help people find the exits or installed near floor level for ease of evacuation in smoke.

13.3.6.2 Procedures for maintenance of emergency lighting fixtures

The testing intervals for the system shall be determined based on the type of usage. More frequent testing shall be done in case of buildings where large public gathering takes place. In any case, this should not exceed six months. However, units that are not

operational between the test intervals should be checked out and repaired on an ongoing basis.

a) *Half yearly procedures*

- 1) Replace any faulty lamps prior to the test procedure. When replacing a faulty lamp it may also be required to replace the lamp starter also.
- 2) Operate the fitting from their battery supply by turning off their normal lighting power supply. This is generally done by turning off the electrical switchboard circuit that is controlling the exit and emergency lighting (*see* Note 1).
- 3) The light shall remain illuminated for at least 90 min.
- 4) Replace any faulty lamps or fittings (*see also* Note 2).
- 5) Turn on the normal lighting power supply and check that the battery charger indicator light on the fitting functions correctly.
- 6) Record details of the test and correct operation of the system. Record the replacement of faulty lamps and the replacement of fittings.

NOTES

1 On some older installations this may also affect general lighting, as the exit lights may be wired on the same electrical circuit. In these cases coordination with building occupants is required to ensure occupant safety during testing.

2 Depending upon the nature of the fault at fixture, fittings can be repaired or replaced as considered expedient and economical.

b) *Yearly procedures*

- 1) Carry out the half yearly procedures.
- 2) Clean down all light emitting and reflecting surfaces.
- 3) Record details of the test, cleaning and correct operation of the system.
- 4) Record the replacement of faulty lamps and the replacement of any fittings.

In addition to the above, a regular programme of inspection should be implemented by the building tenants to check that all maintained exit and emergency lights are operating as required.

The emergency lighting system should include adequate facilities for testing and recording the system condition. Appropriate testing should be carried out to ensure towards maintaining compliance of the system. These need to be appropriate for the specific site and should be considered as part of the system design. The tests include function test and discharge test.

13.3.7 In addition to above, the procedures for maintenance of electrical equipment to ensure their smooth functioning as given in Annex E as also provisions of Part 8 'Building Services, Section 2 Electrical and Allied Installations' of the Code shall also be complied with.

14 OPERATIONS AND MAINTENANCE OF LIFTS AND ESCALATORS

The essential requirements for the operation and maintenance and also inspection of lifts and escalators to ensure their safe and satisfactory performance are covered hereunder. Generally lifts designed for passenger usage should not be used for movement of goods, etc.

14.1 Acceptance

The purchaser should accept the lift installation only on completion of testing and commissioning with all necessary standards and documents, for example third party insurance cover of passengers and belongings, licence from the regional lift inspectorate along with lifts handing over certificate, etc.

It shall be ensured that two numbers of door open keys, operation manual, auto attendant keys and machine room keys are handed over to the owner.

14.2 Guarantee and Servicing

To ensure the continuance of satisfactory and safe operation, the purchaser (or building occupier) should arrange for the completed lift to receive regular servicing by competent persons at such intervals as the type of equipment and intensity of operation demands. Beyond free maintenance period, a comprehensive maintenance contract with the lift/escalator manufacturer is desirable and need to be entered into.

The maintenance contract shall be all inclusive including cost of manpower/supervisor/engineer as required, regular servicing, intermediate service calls, repairs and replacement of worn parts. If the owner decides to exclude provision of some major parts from the scope of maintenance contract, such exclusions should be clearly mentioned in the contract. However, this list should be bare minimum so that lift installation is not out of commission for delay in procurement of parts.

The building owner should ensure that the equipment is properly used, and that unauthorized persons are not permitted to enter the lift shaft, pit or machine rooms. Particular attention should be paid to ensure that lifts are not overloaded or misused specially when they are used in connection with furniture and equipment removals, and internal redecoration and other similar

activities, which may be undertaken within the building.

14.3 Statutory Examinations

Lifts in certain premises (residential and commercial) are required by statutory regulations to be examined at intervals, as specified by the state Lift Acts, by a competent person, who is required to report on a prescribed form. Such reports should normally be kept in a register. Statutory examinations are not a substitute for servicing; the provision of statutory examinations and reports may be specially included in a service contract or may be arranged separately.

14.4 Service Contract (Annual Maintenance Contract)

Generally this is a document which is made in interest of lift purchaser and manufacturer within agreed terms and conditions by both parties. This document has the contact details of both parties with escalation matrix for all the related communications. Service contract period depends on purchaser and manufacturer's mutual decision. Generally service contracts are made for 12 months.

There are two types of service contracts, namely,

- a) *Comprehensive contract* — This covers all the man, material and machine required for meeting the best performance of the lift or its connected equipment. Normally car enclosures, door panes, false ceilings, car gates, lights with fixtures, hand rails, mirrors, starters, chokes, floor coverings and carpets, others architectural features, hoistway enclosures, landing gates, door frames, external wiring, fans and batteries, etc, are not included. However all terms and conditions, inclusions and exclusions shall be fully clarified and documented. Manufactures normally do not cover damages caused by mishandling and acts of God (such as natural disaster, riot, blackout, brownout, flood, fires and earthquakes). Service level agreement (SLA) for rectification of deficiencies shall also be amply documented.
- b) *Non-comprehensive contract* — A non-comprehensive contract does not have the provisions to cover the parts of lifts; in such cases manufacturer provides the parts on chargeable basis as per industry norms, wherever required. In this type of contract, manufacturer has to provide the services for attending call backs and preventive maintenance and rescue operation in case of man entrapments.

14.4.1 Manufacturer's Responsibilities

Manufacturer is liable to fulfill all the requirements of

the purchaser with reference to lifts as given in **14.4.1.1** and **14.4.1.2**.

14.4.1.1 Deployment of manpower

The lift maintenance contractor shall deploy adequate quantum of skilled technicians/supervisor/engineer with proper PPE (Personal Protective Equipment) to attend to servicing/maintenance/repairs/rescue operation as required.

When the lift number is substantial or lift service is critical like hospitals, the maintenance contract may provide for manning the lift control room by a skilled and trained staff to attend to emergency calls from the lifts and to attend to emergency rescue operation, or any emergency situation.

The lift manufacturer shall train few earmarked personnel like security staff pertaining to safe method of rescuing trapped persons.

14.4.1.2 Statutory approvals and compliances

Lift manufacturer will provide all the required liaison to obtain the lifts licence form the competent authority, lift insurance. Annual equipment safety certificates should also be obtained from competent authority as may be required.

14.5 Equipment's Operations

Operation of some important lifts equipment that shall be kept functional and needs to be monitored is described below:

- a) *Emergency alarm operation* — This is a general bell and situated inside the shaft at ground floor in conception with car operating panel (COP). It shall be ensured that this is in working condition at all the times and shall be pressed in an emergency situation.
- b) *Intercom/Press to talk operation* — This is also an important and necessary equipment and shall generally be located in lift car and parallels connected to lift lobby/control room and machine room. Intercom shall be hung on car panel or located on COP with a symbol to make easier identification for users.
- c) *Emergency lights* — There shall be a provision of emergency lighting in cab to ensure proper illumination in it in case of main supply failures or emergency.
- d) *Door open and door close (DO and DC) operation* — A door open button shall be available in the COP towards the car gate to reverse the closing motion and hold the door. Door closing button shall also be provided in COP next to DO button. DC shall operate when user wish to close the door before its

normal dwell time.

- e) *Auto attendant mode operation* — There shall be a key operated switch in the COP and shall be operated by the attendant to take lift in manual control.
- f) *Automatic rescue device (ARD) operation* — This shall be provided in accordance with Part 8 ‘Building Services, Section 5 Lifts, Escalators and Moving Walks : 5A Lifts’ of the Code. In the event of power interruption, ARD which is powered by an internal battery shall operate within 15 - 20 s, enabling the arrival of lift to the nearest floor at slow speed and open the doors to let the passengers evacuate. Condition of the ARD batteries shall also be checked regularly as per manufacturer guidelines and entry of the same shall be made in ARD’s battery log card. ARD batteries should be replaced if their condition is found unsatisfactory. Poor condition of batteries adversely impacts the functioning of ARD and compromises on safety of the lift.
- g) *Over speed governor (OSG) operation* — OSG is a safety device which is engaged with lift car or counter weight. It is an automatic device which brings the lift car or counter weight to rest by operating the safety gear in the event of the speed in a descending direction exceeding a predetermined limit.
- h) *Door safety (Sensor) operation* — This is a very important safety function located at the front edge or back edge of car door. This is known by different names, such as, as door sensor, door screen, etc. Door sensor shall protect full height of the door, covering at least 1 600 mm of car door height from bottom. Selection of the type of sensor to be supplied should be such that even slightest encumbrance will ensure that the doors do not close.
- j) *Fireman lift operation* — It is a mandatory requirement and shall be implemented in all the lifts, individual or in group, with minimum of 1 or 2 h (or as may be prescribed by competent authority) fire rating. Two way (ON/OFF) fire switch shall be common to all in case of group of lifts, and individual fire switch for single lift, to evacuate the lift at ground floor, protected in a box with glass in front with suitable level indication that it is a fireman switch. When the switch is on, all the landing calls for all the floors shall become inoperative and the lift shall be on car control only after reaching at parking floor which is generally at ground, and shall park at with open door condition. Fireman lift should work only

when the door close button is pressed continuously. In this exercise all the landings and car calls will not respond and remain inoperative.

NOTE — Fireman’s lifts shall be clearly identified with the word ‘FIREMAN LIFT’ at all the landing floors.

Maintenance and routine check of fire lift shall be carried out as per the schedule given below:

<i>Frequency</i>	<i>Requirement</i>
Weekly check	Operating the fire switch by building maintenance staff that should check that the lift returns to the parking floor with its door open
Monthly check	Simulate failure of the primary power supply. Building maintenance staff should operate the fire switch and observe its operation by entering few calls
Half yearly check	Inspection and testing of the operation sequence of the lift should be made
Annual check	A full operation test of the lift should be performed at least once in a year. A record of this test should be retained and maintained

- k) *Lift full load operation* — In case of lift full load, all the landing call shall be inoperative and only car calls made from inside the cab shall be active to satisfactorily serve the users. This full load setting should match with the full load setting agreed for the lift.

14.6 Preventive Maintenance

Modular based preventive maintenance method shall be implemented to ensure safety, availability of lifts. Maintenance modules are categorized into modules and the effectiveness is monitored through site audits. For keeping proper records, manufacturer should generate the reports and log cards. Manufacturer shall provide a schedule of plan preventive maintenance (PPM) to the user. Preventive maintenance profile should be as per the prescribed format, a typical example of which is given in Annex F.

14.7 Checks

14.7.1 Checks for Lifts

- a) *Daily checks* — Lifts and connected parts should be checked by user on daily basis as per the typical check list given in **G-1**.
- b) *Monthly checks* — Lifts and connected parts

should be got checked by user on monthly basis as per the typical check list given in G-2.

14.7.2 Checks for Escalators

- a) *Daily checks* — Escalators and connected parts should be checked by user on daily basis as per the typical check list given in G-3.
- b) *Monthly checks* — Escalators and connected parts should be got checked by user on monthly basis as per the typical check list given in G-4.

14.8 Call Backs

Every call back or complaint related to lift should be reported by user to manufacturer on 24 × 7 basis. Manufacturers normally provide a toll free number to the users with 24 × 7 serviceability and an acknowledgement number is issued to the user.

14.9 Man Entrapments Rescue Operation

Lift rescue operation is an important function and responsibility of the lift technician/ manufacturer engineer/trained person to ensure safe and smooth lift rides. Following measures are taken in such eventualities:

- a) *Automatic rescue device (ARD)* — In the event of intermittent power, the lift should automatically restart once supply is restored or ARD shall start working within 15 s to 20 s. When there is power shut down, the lift moves to nearest floor to let the passengers out provided there is no fault in the system. Passengers get trapped only when there is any electro-mechanical fault in lift.
- b) *Rescue operation procedure*
 - 1) As soon as the call is received from lift car about the trap (by intercom or by hooter noise), facility management team shall call the call centre of the service provider/lift agency and register call while simultaneously informing rescue team of service provider available in the building.
 - 2) The passengers shall be informed (using intercom) that they are going to be rescued soon, so nobody should get panicked and nobody should try to open the car door. It will be better to reach the floor and knock the door during rescue operation to ensure presence.
 - 3) Communication shall be continuous with the passengers in the lift to avoid the panic situation while entrapment.
 - 4) Respective lift machine room shall be

reached immediately and the level of lift shall be checked from the rope marking with reference to floor level marking; also the shaft light of the respective lift should be switched on;

- i) One should also try to reset the lift by switching off the main incomer panel and switch it on again after 10 s.
 - ii) If there will be any fault which may get resolved after reset then lift will operate and come to the level and the doors will open to let the passengers out from lift.
- 5) If lift is found to be at level and or near level as per the rope level marking;
 - i) Main supply should be cut off from main incomer panel of that particular lift and ARD shall also be switched off.
 - ii) The floor where the lift car has landed shall be reached; then the landing doors should be opened manually by hand (not by inserting de-locking key); lift doors will open smoothly if the lift is on level and the passengers may be taken out and rescued.
 - 6) If lift is out of level as per rope level marking, services team shall not try to rescue by any means. They shall follow up with service provider and wait until the arrival of lift agency's rescue team for rescue operation. Communication shall be continuous with the passengers in the lift [see SI No. (3)].
 - 7) If lift agency/service provider does not reach within 10 min, building manager and service provider shall be informed for further action.
 - 8) After the successful rescue operation, the lift shall be shut down 'Lift Under Service' signage shall be put in front of the landings. The service agency shall then be informed for their investigation and corrective actions. Lift should not be operational until it gets fully checked and confirmed by lift agency for its safe working.

14.10 In addition to above, the requirements of ARD, fireman's lift and other lift equipment and also procedures for maintenance of lifts and escalators as given in Part 8 'Building Services, Section 5 Lifts, Escalators and Moving Walks' of the Code shall also be complied with.

15 MAINTENANCE OF FIRE FIGHTING SYSTEMS

15.1 Maintenance of fire detection and suppression systems in any facility is a very important task for the facility manager. All owners shall arrange to deploy adequate number of trained people to man the systems and also ensure adequate budgetary support to enable proper maintenance and upkeep of the systems.

15.2 Besides properly maintaining all systems, such as fire detectors, sprinklers, first aid fire equipment, yard hydrants, fire tanks, fire pumps, etc, it is imperative that all fire exits and staircases are kept free from any form of obstruction to allow easy egress of occupants in case of any fire incident.

15.3 At the time of commissioning of any facility proper testing of all fire detection and suppression systems shall be done in accordance with relevant Indian Standards and proper record of same shall be maintained. Wherever lift lobbies, staircases, lift wells or any other such location has been designed to remain under pressure from firefighting point of view it is imperative that necessary pressure fans, etc, are kept properly maintained so that there is no failure in this regard. Security guards/lift operators shall be guided to ensure that, wherever doors have been provided to maintain differential pressures are closed to ensure proper functioning.

15.4 Similarly smoke extraction fans, fire dampers in HVAC systems shall be periodically (at least a fortnightly check is desirable) run and tested to ensure that they function properly in case of any emergency.

15.5 The facility manager shall hold regular mock firefighting drills so that people are made aware of the systems installed, the location of nearest exits, etc.

15.6 Maintenance of fire extinguishers shall be carried out in accordance with the good practice [12(6)]. Periodic inspection, testing and refilling shall be got done from competent and trained persons as per provisions given in the above mentioned good practice and as per recommendations of the manufacturers. Proper records of this activity shall be maintained. All fire detection systems shall be strictly maintained in accordance with the good practice [12(7)]. Facility manager shall ensure that during any fit out or refurbishment, no detector is subjected to any interior decoration treatment such as painting, alteration of exterior cover to conform to the environment.

15.7 A log book should be maintained for recording details, including causes of all the alarms (genuine, test or false), faults service tests and routine inspections, servicing/repairs, etc, as and when done. Period of disconnection/non-operation should also be shown.

15.8 Checks shall be made every day to ascertain that the fire panel indicates normal operation and if not, then any fault indicated should be recorded in a log book and corrective action taken and record of that should also be maintained. It shall be ensured that any fault warning recorded the previous day has received attention. The control panel shall be manned regularly so that in case of any incident, immediate action can be initiated.

15.9 Success of any firefighting system will depend upon timely and proper functioning of the fire pumps. Regular maintenance of these pumps shall be done in accordance with the good practice [12(8)]. Checking of jockey pumps shall be a daily exercise. Adequate stock of diesel shall be maintained in a safe location to ensure that pumps can be operated for design duration.

15.10 Other fire installations such as external fire hydrants, hose reels, etc, shall be checked periodically and shall be maintained. External fire hydrants shall be inspected, checked and maintained in accordance with the good practice [12(9)]. Internal fire hydrants and hose reels on premises shall be maintained in accordance with the good practice [12(10)]. Automatic sprinkler system shall be maintained in accordance with the good practice [12(11)].

15.11 Fire Water Reservoirs/Tank

It shall be ensured that fire water tank reservoirs are always full and free from any foreign materials. The water level shall be recorded weekly. Reservoirs shall be cleaned at least once in a year or more frequently depending upon quality of water and sludge formation shall be prevented.

Records of inspection, testing and maintenance operations and reports of hydraulic pressure tests of extinguishers and other equipment shall be maintained as per history sheet.

15.12 All maintenance operations shall be carried out as a well-planned exercise to ensure that the facility is not subjected to unnecessary risk.

- a) *In case of planned shut down:*
 - 1) Authorities shall be kept informed before shutting of the installation for any reason, whatsoever.
 - 2) A thorough assessment of the risk shall be undertaken before a part or total shut down to ensure that there is no incident of fire during shut down.
 - 3) The heads of all the departments, tenants, RWAs shall be notified in writing that the installation shall remain inoperative and they shall exercise abundant caution during the period.

- b) *In case of unplanned shut down* — When the installation is rendered inoperative as a matter of urgency or by accident, the measures stated above for planned shutdown shall be implemented with least possible delay.

15.13 Fire Drills

Carrying out regular and periodic fire drills, at intervals as may be prescribed, is essential to ensure preparedness of personnel and testing of equipment to ensure that all systems function smoothly in case of any exigency.

15.14 All assets used for firefighting and fire prevention can be equipped with sensors. These sensors shall be capable of monitoring the health of the equipment. Sensors should log the status and send to the central database at monitoring station or BMS, where provided.

15.15 Staircases, fire exits, refuge areas, passages, open surroundings inside or outside the premises should be kept clear of goods.

16 ROADS AND PATHWAYS MAINTENANCE AND UPKEEP

16.1 General

Like other facilities, great care in planning and construction stage is very important for roads/pavements/paths for their subsequent maintenance and upkeep. It is to be ensured that the roads are well planned and foot paths/pavements provided are at a standard height (usually 150 mm) above the road surface so that they do not cause obstruction to the vehicles and are easily manoeuvrable. All services required at the time of construction including those anticipated in future should be taken care of in the planning stage itself and adequate provisions shall be made for them from the very beginning. This will ensure that the roads are not required to be dug/cut time and again for laying of such services and also the laying of services will be efficient and economical once these are thought of and incorporated well in advance.

16.2 External Services

Special attention needs to be paid to the drainage of the area as storm water drains, more often than not, remain unplanned in the early stages of any project and the areas get inundated during rains causing inconvenience to the users. Proper survey and outlets for the rain water shall be ensured while taking up the work of the residential or commercial complexes. Need for rainwater harvesting systems has already been explained and emphasized (*see 11.7*). These provisions have to be taken into account while designing roads/pavements and paths. All external services should be planned and coordinated before execution. Care has to

be taken to ensure that the sewer lines do not run above water lines and also do not cross potable water lines as far as possible.

16.2.1 Ease of Movement

While laying out foot paths/walk ways and cycle tracks traffic studies shall be carried out, junctions and crossings shall be well planned. It should be ensured that foot paths/walkways are easily approachable and are user-friendly especially to elderly people and persons with physical disabilities. A simple test for the same can be to make a person walk with a trolley and he should be able to move around without having to lift the trolley at any point.

Action at design stage should be taken to develop a safe and effective network of cycle paths. Footpaths and cycle paths are provided to assist the community with walking and cycling activities. Walking and cycling need to be encouraged as modes of transport as they,

- a) enhance fitness, health and general life enjoyment;
- b) reduce traffic congestion;
- c) reduce greenhouse gas emissions; and
- d) reduce public expenditure on new roads and car parking facilities.

Damage to paths mainly arise from aging infrastructure, vehicle overrun or through tree roots lifting the paths.

16.3 Maintenance Requirements

Materials used for footpaths and walkways need not be very costly but should be of good quality and durable so that the maintenance needs remain minimal. Attention needs to be paid to regular cleaning of drains and walkways for which the time schedule can be drawn up depending upon the usage and expectations.

All roads present maintenance problems in varying degrees depending upon the specifications and standard of execution at construction, change in traffic intensity/pattern, climatic conditions natural calamities. In the case of concrete roads, the repairs to the roads are more or less as those applied to any other concrete works.

Road layouts indicating location of culverts, cross drainage and other underground services shall be prepared and kept available with the facility manager and exhibited in office. Different types of roads like gravel, bituminous, or concrete roads should be indicated along with length of the each stretch. A register of roads indicating total length of different types of roads shall be maintained. Similarly, a register of drains/culverts and cross drainage works shall also be maintained indicating type, length/span, etc.

16.4 Inspections

The minimum frequency of inspections of road conditions shall be specified. Permanent surface evaluation based on surface condition like cracking, patching, riding quality, road roughness and skid resistance will form the basis for taking periodic maintenance decisions. The data collected as a result of inspection should be recorded methodically. The condition of road assets, including community paths and pedestrian areas should be regularly inspected, with focus on areas with high pedestrian usage. Priority for inspections should be given to intensively used areas.

During inspections following observations should be carefully noted:

- a) Carriageway and crust conditions;
- b) Berms — gullies and erosion;
- c) Road side drains;
- d) Road protection works — retaining walls pitching on slopes, weep holes;
- e) Safety aspects:
 - 1) Cuts on roads,
 - 2) Over hanging branches of trees shall be above 4.5 m,
 - 3) Vertical clearance from power lines, and
 - 4) Berms should not be lower than 25 mm from carriageway;
- f) Maintenance of the bituminous road surfaces:
 - 1) Surface defects on account of defective quantities of bitumen;
 - 2) Cracks — longitudinal, edge and hairline cracks; and
 - 3) Bleeding on account of binder moving upwards and collecting on the surface.

Maintenance of walkways, roads and paths should specifically ensure proper maintenance of accessibility features provided, to facilitate movement of people with disabilities.

16.5 Routine Road Maintenance

Following shall be attended to as part of routine maintenance activity:

- a) Periodic inspections should be carried out;
- b) All patch repairs and rectification of undulations shall be attended well in time;
- c) Shoulders and the side drains to be kept in camber/cleaned;
- d) Proper signage to be provided;
- e) Soil erosion to be avoided; and
- f) Vegetative cover should be established on cut/ fill slopes.

16.5.1 Permanent Maintenance Management System (PMMS)

Permanent maintenance management system is used for managing or directing and controlling maintenance resources in a scientific manner for optimum benefits for major road system. Matching of resources time materials and labour equipment, funds, design and timely decision-making is an integral part of PMMS. The required data of assets to be maintained should be collected and made available to the facility manager who will be able to identify requirements of funds, labour, materials and equipment for maintenance works based on the methodology to be adopted.

16.6 Environmental Concerns

Environmental concerns are also to be looked into to reduce the vehicle operating costs and levels of emission from road traffic. Urban roads have unique features which need to be accounted for in the maintenance norms so as to ensure that the maintenance is carried out in right perspective. These features include traffic signals, pedestrian walkways, cycle tracks, street furniture, footpath, service lanes, streetlights, etc. Even removal of dead animals becomes a part of maintenance. These roads are subjected to continuous flow of traffic thereby giving only very limited working hours for maintenance purposes hence high level of mechanization is required. Proper monitoring of the maintenance works needs no emphasis. While carrying out design work for the roads and pavements it shall be ensured that there are no deficiencies left in the crust thickness.

17 HEALTH AND SAFETY REQUIREMENTS

17.1 Personal Protective Equipment (PPE)

17.1.1 Many hazards exist in work environment which cause thousands of injuries and health problems every year. Working at a site involving constructional work/ maintenance work can pose a serious/fatal threat to the personnel involved if appropriate PPEs are not used. PPEs are protection gears used by individuals to reduce the consequence of specific risks in the work place, for example, safety helmet, safety shoes, gloves, etc.

All the PPE shall be suitable for the industry need and comply with the requirements of relevant Indian Standards. There shall be zero tolerance and no compromise on the safety at all the times. All PPE shall be maintained in optimum condition to ensure longer sustainability and durability and stored properly in easily accessible locations

17.1.2 PPE being the basic requirement, shall be supplied to all the employees, labour, contractors vendors and suppliers to protect themselves as well as

others. Respective units as field and factory shall incorporate specialized PPE for operation in their respective operational control procedures.

17.1.3 Responsibility

Each one in the premises involved in work environment shall be equally responsible to ensure use of the PPE as per HSE Manual and safety code. The need and importance of safety measures shall be explained to each worker on day-to-day activities at work place.

17.1.4 General Requirements

- a) Use PPE properly according to the nature of work.
- b) Awareness of the correct way to use PPE. This may be done by training, reading and discussion on the usage of manual of specialized PPE.
- c) Regular checking, cleaning and maintenance of PPE. PPE shall be maintained in good shape and condition to ensure that the purpose is served.
- d) Information to be given to supervisor regarding need to repair and replace PPE.

Each establishment shall prepare and notify safety requirements and guidelines for use of PPE. Non-adherence to the guidelines so prepared should be treated as an offence. If any personnel are noticed for non-compliance, it shall be reported to line manager or work manager for appropriate disciplinary action. This shall be a general practice to impart refresher training to all the employees meeting their other training needs as tool box talk before starting any task.

17.1.5 Use of PPE for Specific Areas

- a) *Maintenance of electrical installations* — All personnel are required to observe the following procedures for PPE use:
 - 1) PPE use is mandatory when contact with exposed electrical sources is likely. Only use PPE that is designed for the work being performed. Inspect and test all PPE prior to use.
 - 2) Use a protective outer cover (for example, leather), if the work being performed may possibly damage the PPE's insulation.
 - 3) Wear non-conductive headgear, if there is danger of electrical burns or shock from contact with exposed, energized equipment. Wear eye and/or face protection, where there is danger of flying objects, flashes or electrical arcs produced by an electrical explosion.
- b) *Maintenance of E&M services* — All workers

employed in maintaining MEP equipment shall be supplied with proper PPE and should be trained to use them properly. Working on machines and plants without proper PPE should be strictly discouraged. Some of the PPE usage which shall be ensured are:

- 1) Use of insulated gloves for electrical maintenance;
- 2) Use of safety shoes for all kinds of maintenance;
- 3) Use of safety helmets if it is a construction site;
- 4) Suitable 'wet floor/wet area' displays to be provided at the time of wet service;
- 5) Disconnect main power supply while attending to any service requirement on the respective equipment;
- 6) Always check with line tester that supply is disconnected;
- 7) Use safety belt and harness if working on building vertical faces;
- 8) Ensure limit switch, fan guard and marine light inside AHUs;
- 9) Ensure adequate lighting at all times during service;
- 10) Use only competent and trained service agencies/personnel;
- 11) Ask service provider's service representative to display identity card before commencing service, to prevent sabotage/industrial espionage; and
- 12) Use genuine/reliable spares.

17.2 Maintenance Tools

17.2.1 A list of recommended tools should be maintained. Out of the list, tools relevant to the specific maintenance activity may be used. All tools and other equipment which are used shall be stored properly and be easily accessible. Wherever tools are to be used for working on hazardous areas, they shall be procured from reputed manufacturers to ensure safety of the workers.

17.2.2 Portable Electrical Tools

- a) Portable electrical tools (especially metal body) should be connected through 30 mA earth leakage circuit breaker (ELCB) only to avoid any injury due to any leakage current.
- b) Portable electrical tools should be double insulated because with regular use, the portable tools insulation gets weak and during the work technician may get injured due to electrical shock.

- c) Portable electrical equipment shall be regularly examined, tested and maintained to ensure that the equipment and its leads are in good order.
 - d) Register shall be maintained for inspection, recording the testing dates and results of the equipment.
 - e) All portable appliances shall be provided with three core cable and three pin plug. The third pin of the plug shall invariably be earthed.
 - f) It shall be ensured that the metal part of the equipment shall be effectively earthed.
 - g) All connections to portable equipment or machines from the panel/distribution board/extension board shall be taken using three core double insulated PVC flexible copper wires in one length. No joints shall be allowed in this flexible wire. In case single length of wire is not sufficient for a particular location then the supply can be tapped by providing another extension board comprising of switch and socket.
 - h) Flexible cables for portable lamps, tools and apparatus shall be regularly examined, tested periodically and maintained to ensure safety.
- j) Senior supervisors, facility managers shall review maintenance operations and records regularly to ensure that proper schedules are being followed and that servicing, etc, of equipment is being done on time.
 - k) Constant emphasis shall be given on safety aspects.
 - m) Regular onsite training will help maintenance personnel to improve their performance
 - n) All maintenance manuals, documents related to equipment, service records shall be kept in a convenient place to allow quick and easy access.
 - p) Wherever a special service request is received, a follow up on the same shall be done after action has been taken to resolve it. This will help in generating confidence of end users in the facility management team and will also ensure that the personnel tasked with resolving the request perform properly.
 - q) Some operations are required to be carried out on a 24 × 7 basis. In all such places, proper provision for a rest room shall be provided.
 - r) Many installations may need deployment of large work force for maintenance and operations. In all such places it will be desirable to provide a proper rest room for the workers or an area for the purpose may be designated so that they can be approached quickly, whenever a need arises.

17.3 Good Practices

Besides ensuring use of appropriate PPE, tools and trained manpower, there are some other aspects which each facility management team should follow. These aspects include the following:

- a) Always ensure that the service provider checks the operation logs, to verify whether plants were operating as they should be.
- b) Always ensure that the vendor prepares a service report and duly signs it.
- c) Always ensure that service report is signed by an authorized person representing the owner.
- d) Always ensure that all components of the plant are maintained as per protocol.
- e) Always ensure that there is a physical meeting between operator and service provider, at the time of each quarterly service.
- f) Never allow unauthorized personnel to enter plant rooms, sub-stations or other installations where machinery or other equipment are installed.
- g) Do not allow wearing of loose clothes by operators and technicians as it can be a potential hazard.
- h) Maintain all plant rooms, sub-stations, electrical panel rooms, etc, neat and clean. Remove all unwanted materials from these

18 MAINTENANCE OF LANDSCAPING AND HORTICULTURE WORKS

18.1 General

Landscape maintenance specifications and management plan is the key to aesthetic environment and pleasant surroundings. Well maintained and manicured green areas not only enhance the value of the asset but also provide relief to the users. The objective is to provide regular time defined services as per the landscape maintenance specifications laid down for the property. This covers hardscape as well as softscape, which are explained below:

- a) Hardscape are primarily the design elements that are solid and remain unchanged as the years go by, examples are rocks, walkways, retaining walls, paver patios, outdoor kitchens, water features, fountains, decks, podiums, driveways, etc.
- b) Softscape are elements that are fluid and change with time. It is the living animated part of a landscape, comprising of elements such

as soil, plants, shrubs, trees, flowers, vegetables, vines, turf, etc.

Maintenance of hardscape and softscape should be ensured as planned. Maintenance of walkways, roads and paths should specifically ensure proper maintenance of accessibility features provided, to facilitate movement of people with disabilities.

18.2 Maintenance of Plants

The fundamental principle of maintenance of in-door and out-door plants means using the right plant and the right place in the property. Indigenous plants, or others well adapted to local conditions, should be used wherever possible. Plant growth rate, size at maturity, life span, brittleness and requirements of light, water and soil pH are important factors in selecting plants, along with their colour, texture, fragrance and seasonal characteristics. Matching plant requirements with site realities and correctly placing appropriate plants helps avoid expensive and time consuming problems.

In case of indoor plants, it is necessary to choose the right location with good light and away from heat, vent and air conditioner. In case of a location with abundant sunlight, in-door plants should be placed in east west facing windows, whereas in case of locations with less sunlight, they should be placed in a north facing window. It is essential to give right amount of water as both too much water and not enough water can be the primary reason for a plants death. Plants should be given plenty of moisture depending on its type. In-door plants should be kept free of pest and dust. Over-time in-door plants become sickly and poor looking as a result of dust build up and insect pest infestation. They shall be cleaned with a rag and organic insecticide soap every few months. Unhealthy growth should be removed. In case of out-door plants/trees, it shall be ensured that they are getting enough sunlight. They should be watered on regular basis. Insects, snags and snails should be killed with organic insecticides. Care of planted area shall be done in accordance with **18.5.1**.

18.3 Regular, weekly maintenance services, as outlined in the landscape maintenance specifications, should be provided and weekly and monthly checklists should be maintained. All landscape areas, including irrigation systems, should be examined on a weekly basis, looking for problems or potential problems so that timely action can be taken. This is essential as the plants once damaged can only be replaced which will require extra financial burden.

18.4 Following documents needs to be maintained in suitable formats for effective monitoring:

- a) Landscape maintenance plan;
- b) Weekly and monthly monitoring checklists;

- c) Attendance register for the garden maintenance team;
- d) Records to be maintained for gardening consumables purchased in a month;
- e) Weekly checks on the gardening tools and tackles; and
- f) AMC for mechanized equipment.

18.5 Methodology and Processes to be Adopted

18.5.1 Care of Planted Area

- a) *Trees* — Trees shall be maintained in a healthy, vigorous growing condition, free from disease and large concentrations of pests. Pruning of trees should be done only in appropriate months. Timely action, to remove dead, diseased, broken, dangerous, or crossing branches, to be undertaken as part of the regular maintenance to encourage a high-branching structure. All non-structural branches between the ground and a point half the tree's total height should be removed (for very tall trees branches higher than 6 m above the ground should not be removed). Trees planted for screening purposes, such as those at rear perimeters of many sites shall not be pruned except as needed to remove dead, diseased, broken, dangerous, or crossing branches. The cutting blades on pruning shears, clippers, blades, saws, etc, shall be sterilized after pruning each tree to minimise the possibility of spreading disease.

A vertical clearance of 2.90 m (114 inches) is required above all parking spaces. A vertical clearance of 2.0 m (80 inches) is required above all walkways. Trim trees to remove all limbs within these areas.

- b) *Shrubs and vines* — Shrubs and vines shall be pruned weekly or as needed to keep them in healthy, vigorous condition, free from disease and large concentrations of pests. Works to be carried out under guidance of a competent professional. Shrubs should be allowed three months to rejuvenate prior to pruning or replacing.
- c) *Groundcover* — Groundcover shall be maintained in a healthy, vigorous growing condition. Groundcover shall be planted at 200 mm spacing from the building to encourage quick coverage. Prior to planting replacement groundcover, the soil shall be tilled to a depth of 150 mm to prepare it for the new plants. The groundcover should be kept trimmed back from sidewalks, curbs, and paved areas on a weekly basis. Vertical edges

should not be created when pruning groundcover. The edges should be cut at an angle for a more natural appearance and healthier plants.

- d) *Weed control* — Weeds in planted areas, sidewalks, curbs, gutters, or pavement shall be removed or killed weekly as the weeds emerge.
- e) *Mulch and/or rock layer* — Soil mulch and/or rock layer shall be cared for, as needed to create and maintain an even and uniform appearance over the visible soil surface of each planter area. Replacement rock shall be of the same size and colour as existing decorative rock on site. In the event no rock is existing, the decorative rock used shall have a maximum diameter of 20 mm and a minimum diameter of 10 mm.
- f) *Fertilizer* — When applying granular fertilizers to drip-irrigated areas, the fertilizer shall be washed in by hand or rainfall before turning on the drip system. Running the drip system immediately after application will push the fertilizer away from the emitters, resulting in a high concentration of fertilizer at the edge of the wetted zone. This highly-concentrated fertilizer can kill or damage plants. It is recommended that granular fertilizers be applied to drip-irrigated areas only in early spring, just prior to a moderate rainfall.
- g) *Lawns* — Lawns shall be kept in a healthy, vigorous condition, free of disease and pests. Lawn height shall not exceed 130 mm at any time, preferred is 3 inches. Lawns should be mowed, edged and trimmed weekly or as required to maintain an even, well-groomed appearance. Visible lawn clippings should be removed and disposed off-site in a legal manner. It is encouraged to use mulching mowers which cut clippings into small pieces that sift down into the lawn. Weeds shall be controlled in lawn areas as described in (d).

18.5.2 Irrigation — Water Application and Scheduling

18.5.2.1 Hand watering should be done, as needed to supplement natural rainfall and maintain plantings in a healthy, stress-free condition, to ensure that plants receive adequate water regardless of weather conditions. Irrigation shall be done by the use of the permanent irrigation systems. Hand watering should also be done, as needed to supplement the permanent irrigation systems.

Watering times shall be adjusted each week. Plantings shall not be over-watered. Multiple-start times and short run times should be used to prevent run-off. Drip

systems should be left on for sufficient time to allow for saturation of the root zone. Shorter runs with drip irrigation do not provide sufficient water penetration for healthy root development. Multiple-start times with drip systems should be avoided, if possible. Run-off should not be allowed from any irrigation.

18.5.2.2 Irrigation system scheduled maintenance

Irrigation system scheduled maintenance shall include the following:

- a) Each valve zone shall be observed for signs of damage on a weekly basis during the irrigation season.
- b) The irrigation system should be maintained, including cleaning of filter screens yearly or more often as needed, and flushing pipes, as part of regular maintenance.
- c) Drip irrigation systems need periodic flushing to remove sediment and shall be performed as per the required frequency. Drip systems shall be flushed at least once a year. Ends of drip lines should be opened and run for at least 15 min at full flow to flush. It may be necessary to install flush outlets in order to flush the drip system.
- d) For safety, sprinklers shall not be installed on risers above the ground level, even if the risers are flexible. Spring-operated, pop-up style, sprinkler heads should always be used. Sprinkler heads are available with pop-up heights up to 300 mm above ground level. If the existing sprinklers are mounted on above-ground risers, the replacements shall be pop-up type sprinklers.
- e) The entire irrigation system should be inspected weekly for items such as dry spots and missing or malfunctioning irrigation components. It shall be checked for leaking valves, water running across sidewalks, water standing in puddles, or any other condition which hampers the correct operation of the system or the public safety. The team shall carefully observe plant materials for signs of wilting, indicating a lack of water.

18.5.3 General Cleaning

While it is essential to maintain all hardscape and softscapes properly it is also essential to ensure general cleaning up of these areas. Cleaning up and litter removal from, all walks, kerbs, and gutters, on weekly basis should suffice. However, frequency may be determined depending upon the usage of the facility. In no case shall trash, litter, or leaves be blown or swept onto the property of others. All trash, litter, leaves, etc, shall be collected, hauled away, and disposed of legally.

Under no circumstances shall dry leaves be burned. Wherever possible, composting of horticulture waste should be resorted to.

18.5.4 Chemicals, Pesticides and Herbicides

All chemicals shall be used in accordance with label directions and the manufacturer's recommended dosage and handling methods and handled in accordance with all applicable regulations. Nothing in this clause shall be construed to be the advice of, or to substitute for the advice of, a pest control adviser whose advice should be sought for use of registered chemicals.

Pesticides shall not be applied within one hour of the start of operating hours for businesses at the site. In the event that it is not possible to complete the application by 1 h prior to business hours (that is, 24 h operations), applications shall be made at times when customer presence is minimal. Areas to be treated shall be blocked off and warning signs posted.

18.5.5 In addition to above, the maintenance requirements as given in Part 10 'Landscape Development, Signs and Outdoor Display Structures, Section 1 Landscape Planning, Design and Development' of the Code shall also be complied with.

18.5.6 Reports

The weekly landscape maintenance checklist shall be complete in respect of all applicable items on the checklist. It shall be submitted to authorized representative each week for review. The monthly landscape maintenance checklist needs to be prepared for month on month requirements as per the season during the year. A typical checklist for landscape areas is given at Annex H.

19 HOUSE KEEPING

19.1 It is an established fact that a 'clean' facility enhances the appeal, productivity of occupants and the value of the facility. Janitorial service standards cover basic features of operations required to be carried out to keep the facility clean. Housekeeping or janitorial services will include, where required, ensuring desired levels of hygiene.

19.2 Methodology and Processes to be Adopted

19.2.1 Adequate staff, having necessary training in carrying out cleaning operations for ensuring required levels of cleanliness, under guidance of trained janitorial supervisor should be deployed. Having trained teams for carrying out these operations will result in better standards being achieved with lesser manpower. The facility management team should draw up plans for achieving the desired standards without disturbing the use and operation of the facility.

Assessment of manpower required needs to be carefully assessed keeping in view all relevant factors.

19.2.2 While carrying out housekeeping activities following aspects should be kept into consideration:

- a) All local laws and regulations are abided by, and
- b) Required protocols of cleaning for all areas of the building and cleaning schedules for all areas of the building are implemented.

19.2.3 Tools and Technology

Cleaning chemicals to be used should have a pH value of (1 percent sol) : 9.5-11.0 and it is desirable to use only green seal certified chemicals, certified by an appropriate authority, and manufactured by reputed manufacturers. This is essential to prevent damage to assets and ensure that no harmful impact is caused to facility/users.

Chemicals used should be safe and should display appropriate hazard warnings and material safety data. Storage of the cleaning chemicals should be done properly to ensure that no untoward incident occurs and misuse can be prevented.

Mechanical equipment like, dry vacuum cleaners, dustette, back-pack vacuum, upright vacuum, pile lifter, wet and dry vacuum cleaner, large tank type vacuum cleaners, carpet shampooing machine/steam extraction machine, high pressure washers, scrubbing/polishing machine, etc, may be deployed as required. Selection of cleaning equipment may be made based on:

- a) *Floor finish* — Vitrified, carpeted, mosaic, marble, granite, etc;
- b) Total area required to be cleaned;
- c) Cleaning standards/frequency required to be achieved;
- d) Time at which cleaning activity is to be carried out and time duration available to complete the process;
- e) Periodicity of the activities, that is, daily, weekly, etc; and
- f) Areas/building component required to be cleaned, for example, glass facades, aluminum composite panel (ACP) sheets, atrium, etc.

Periodicity of the activities can be classified into: daily, weekly, monthly or annually.

19.2.4 Periodic Tasks

The activities to be carried out at intervals mentioned above shall be enumerated and the facility management team shall be aware of the same and should carry out these activities at specified intervals.

19.3 Documentation Required to be Maintained for Effective Monitoring

Like other services, proper documentation of housekeeping services shall be maintained to ensure proper execution, review and control. Following details may be maintained:

- a) Supervisors check-list;
- b) Deployment sheet;
- c) Attendance register;
- d) Week-end check-list;
- e) Incident tracker;
- f) Chemical consumption record; and
- g) Machinery running and maintenance report.

19.4 Evaluation and Recommended Frequencies

As housekeeping is a function which shall be carried out strictly as per desired schedule, it is desirable that service level agreement (SLA) shall be reviewed and findings documented.

Recommended frequency of evaluation should be once every month.

19.4.1 Measurements and Recording of Non-conformance

Non-conformance can be measured through e-mail/ telephonic/written/verbal report received from the employees/end users. Number of times the default has occurred in a month shall also be recorded. Any escalation on the help-desk/help-line will be categorized as non-conformance except for request. Any incident/default will be measured as a single unit.

19.4.2 Non-conformance to SLA may be classified as:

- a) *High* — Any event which compromises with business continuity, life threatening incident, loss of reputation, major financial loss.
Non-conformance recording — Default twice in a month equals to one non-conformance.
- b) *Medium* — Default observed in the adhering to bench-marked cleaning standards defined for the property.
Non-conformance recording — Default thrice in a month equals to one non-conformance.
- c) *Low* — Any event causing minor annoyance.
Non-conformance recording — Default four times in a month equals to one non-conformance.

NOTE — The above being recommendatory, appropriate measures should be taken by the facility management team based on the type of usage of facility.

19.4.3 It is desirable that the facility management team sets benchmarks for measuring performance and non-

compliance. It is recommended that a score of 95 percent or above may be accepted as having complied with the SLA and a score of 50 percent or below may be taken as to indicate failure of the housekeeping team.

19.4.4 A typical template for measurement and recording of conformance or otherwise with respect to housekeeping is given at Annex J.

19.5 Training and Skilling

Cleaning supervisor/cleaning personnel (janitor/ chamber-maid) should have required skills and attitude and eye for detailing. Regular onsite training should be carried out. This will help in improving delivery of services by the personnel. During training, housekeeping staff should be sensitized on needs of persons with disabilities, elderly and frail people and children in particular.

Housekeeping staff should also participate in, and also be trained to participate in all safety and disaster related activities.

20 PEST AND RODENTS CONTROL

20.1 Overview

A clean environment and prevention is the starting point of pest control. Keeping harmful pests at bay results in preventing loss and ensures a healthy and safe environment for the users. Pest control is the process of eliminating or minimizing a wide range of undesirable pest and insects. A watchful eye and alertness to detect tell-tale signs of pests helps to take adequate timely action. Certain kind of pests can be a great health risk and can cause safety issues for any premises. Engaging a professional service partner to manage the pest control brings about desired results.

Integrated pest control management is a holistic approach encompassing prevention, monitoring and control techniques with larger goal of suppressing pests by application of least toxic measures. Preparation of an integrated pest management plan can be very useful and following guidelines may be considered in its preparation:

- a) Preventive measures should be explored;
- b) Alternative methods of control to be evaluated;
- c) Timely action for effectiveness and safety;
- d) Most effective method to be adopted that has cost benefit and least environment effect; and
- e) Adequate monitoring and documentation.

NOTE — It is recommended that control measures be adopted only when the problem occurs.

20.2 Methodology and Processes to be Adopted

20.2.1 Tools and Technology

Various tools and equipment employed in pest control are hand operated sprays, foot operated sprays, gum pads, gel guns/syringes, fogging machines, etc. These may be used/deployed as required.

20.2.2 General Management

20.2.2.1 Prevention techniques

An important step, as it eliminates the pests by disturbing its environment, can be through physical barriers or elimination of source, as described below:

- a) *Elimination of ingress points:*
 - 1) Allow food and beverage at designated areas only.
 - 2) Keep areas dry, eliminate stagnant water.
 - 3) Carpeted areas to be vacuumed frequently.
 - 4) Precautions for food preparation and serving areas with due attention to storage, cleaning and waste disposal practices.
- b) *Monitoring techniques* — Good monitoring is a cost effective aspect of integrated pest management, forming the basis for control techniques. Regular, systematic inspection of the facility is essential to be effective. It may include the following:
 - 1) *Tell-tale signs* — Sighting of pests, damage, droppings, tracks and traces.
 - 2) *Thresholds* — Mere presence need not trigger control action but sizeable presence warrant actions.
 - 3) *Traps* — Very effective method of monitoring and helps reduce usage of chemicals and pesticides.
 - 4) *Data to be recorded systematically* — Helps to detect pest problems and compare outbreaks season to season. Records should be maintained to capture dates, temperature, location of infestation and control action taken.
- c) *Control techniques* — Use of control techniques to be on the basis of proven efficacy, low environmental impact, operational feasibility and cost effectiveness. Control methods by use of chemicals is most effective while cultural, mechanical, physical, biological methods contribute greatly towards prevention. Special control techniques may also be employed based on case specific requirements. Best practices for this aspect

include the following:

- 1) Training of personnel;
- 2) Usage of personal protective equipment (PPE);
- 3) Usage of green chemicals; and
- 4) Usage of low toxicity chemicals.

Periodicity of activities can be daily, bi-weekly, weekly, fortnightly and monthly.

20.2.2.2 Documents like integrated pest management plan, pest monitoring checklists in appropriate formats should be maintained for effective monitoring.

20.2.2.3 Evaluation and recommended frequencies can be laid down by each establishment depending upon location, use and infestation of pests.

21 SECURITY SERVICES FOR BUILDING OCCUPANTS AND ASSETS/FACILITIES

21.1 The primary aim of security in a building occupied by people for various purposes is to take adequate measures to deny all opportunities of acquiring information, committing sabotage and subversion activities by antisocial elements. The security issues shall be addressed in using integrated design process with an understanding of the impacts and goals of other design objectives. While ensuring safety and security measures adopted, the staff deployed should take into account needs of persons with disabilities, elderly and frail people, women and children in particular.

The physical security addresses the threats, vulnerabilities, and countermeasures that can be utilized to physically protect an asset's resources and sensitive information. These resources include people, the facility in which they work, and the data, equipment, support systems, media, and supplies they utilize. These guidelines assist in the identification of physical security measures that can be applied at facilities to safeguard or protect an organization's asset, that is, people and property. Security measures required for keeping information secure are not covered herein.

There are generally eight main categories of physical security measures used to protect buildings. These categories are listed below and need to be kept in view while planning and providing security services:

- a) Crime prevention through environmental design (CPTED);
- b) Physical barriers and site hardening;
- c) Physical entry and access control;
- d) Security lighting/illumination of the vital installation;
- e) Intrusion detection systems;
- f) Electronic/video surveillance;

- g) Physical deployment (engagement of security personnel); and
- h) Security policies and procedures.

21.2 Threat Types

Some types of threats to be considered include the following:

- a) Unauthorized entry/trespass (forced and covert).
- b) Insider threats.
- c) *Explosive threats* — Stationary and moving vehicle-delivered, mail bombs, package bombs.
- d) *Ballistic threats* — Small arms, high-powered rifles, drive-by shootings, etc.
- e) Weapons of mass destruction (chemical, biological, and radiological).

21.2.1 Suitable measures at design, construction and maintenance stage need to be taken to ensure that threats of unauthorized entry (forced and covert) are taken care of.

21.3 Methodology and Processes

21.3.1 Threat and Risk Assessment

A security system is generally not effective unless it is developed based on an understanding of the actual threats and risks it is designed to control. The development of a threat and risk assessment for a facility involves the following steps:

- a) *Preparation* — Determining what to protect,
- b) *Threat assessment* — Determining what to protect against,
- c) *Risk assessment* — Determining if existing or proposed security measures are satisfactory, and
- d) *Recommendations* — Identifying what should be done.

21.3.2 Site Development

A safeguarding strategy should be defined and used to develop a security site brief (SSB).

The institution or tenant should prepare a SSB for leasing existing facilities, because custodians generally seek existing space as a first option. If it is determined that existing space is not available or is not the first option, then another SSB for constructing facilities should be prepared. Once selected through a build, buy or lease process, the site is subjected to a survey to determine site specific security-related problems. These problems may include neighbourhood vandalism, theft or violent crime. This information is considered along

with the facility threat and risk assessment and allows the safeguarding strategy to be adjusted as required and adequate safeguards to be developed for the site.

21.3.3 Security Strategy

21.3.3.1 The security strategy should be based upon the following principles:

- a) Segregation of public and private areas;
- b) Segregation of high and low security level areas;
- c) Access control;
- d) Surveillance;
- e) Alarm generation;
- f) Physical security;
- g) Screening of personnel and vehicles;
- h) Layered security through multiple tiers;
- j) Crime prevention through environmental design (CPTED); and
- k) Response to potential threats and incidents.

21.3.3.2 Key security measures

- a) *Vehicle movement plan* — There will be several options available for movement of vehicles. The final plan should be based on smooth flow of traffic that will promote uninterrupted traffic for all types of vehicles. Ideally there should be separate entry and exit points. Security demands minimum entry and exit points to ensure proper screening and checking of vehicles.
- b) *Pedestrian movement plan* — Movement of pedestrian should be restricted to one entry, if possible. There should be proper arrangement for screening of pedestrians including cabin for female pedestrians.
- c) *Fire engine movement plan* — Arrangement shall be made for entry, exit and movement of fire engine. Adequate turning radius shall be provided within the entire complex. Ideally there should be separate entry and exit point to ensure regular flow of fire engines, if necessary.

21.3.3.3 Security managers/security personnel's responsibilities shall include among other things the following:

- a) Physical security of the organization's assets;
- b) Development and enforcement of security policy and procedures;
- c) Crisis management;
- d) Business continuity planning;
- e) Executive protection within building/facility;

- f) Preliminary investigation of security incidents;
- g) Employee security awareness;
- h) Law enforcement and governmental liaison;
- j) Workplace violence prevention;
- k) Security systems management;
- m) Assisting in preventing and fighting any fire incident;
- n) Periodic threat assessment of the building;
- p) On the job training of the security staff;
- q) Regular conducting of evacuation drills;
- r) Maintenance and upkeep of the security gadgets; and
- s) Monitoring of security situation by electronic surveillance

Security manager can be direct employee or contractor to the organization. Security managers should be assisted by security supervisors and security guards whose duties should be detailed to cover all required aspects as given below:

- 1) Supervisor should ensure that all the norms related to safety are followed by all.
- 2) He should be aware of emergency action plan of the premises and ensure that all guards and employees are also aware of it.
- 3) Security supervisor shall know the locations of fire points, hydrant points, emergency exits, fire alarm break glass switches and first aid junctions, etc within the premises. At the same time he is to take initiatives to ensure that guards and all the employees also know about the above mentioned points.
- 4) Supervisor shall ensure that telephone numbers of all key personnel and emergency numbers are readily available at each post for the use during emergencies.

21.3.4 Common Service Standards

21.3.4.1 Patrols

Frequency of patrols shall be agreed and timetabled and records of all patrols shall be kept.

21.3.4.2 Controlled access during out of hours

- a) During out-of-hours shifts only specified access and egress shall be used which the security staff should control.
- b) At no time shall unauthorized individuals be allowed into the premises.
- c) Any person not wearing an appropriate pass at any time, including recognized staff, shall be challenged to ensure that any and every

person has a valid reason for being on the premises.

- d) The scanning/vetting of any items received outside core service hours, other than pre-notified scheduled deliveries, shall be controlled by security staff.
- e) All security personnel shall receive adequate training for this purpose.

21.3.4.3 Vehicle access control

Vehicles have been a major threat to security of any asset. These can be used for bringing armed intruders, smuggling of explosives, arms and other contraband items. Measures to secure premises/complex should include the following:

- a) *Vehicle ramp schemes* — Vehicle barriers, as given below should be designed and installed at all vehicle entry/exit points.
 - 1) *Boom barriers* — Boom barriers perform the majority of access control functions for regulating vehicular traffic into and out of control areas. The boom barrier can be operated with radio frequency identification (RFID) to enable unobstructed entry to select clients. Tags for smooth flow during peak hours may also be considered.
 - 2) *Retractable bollards* — Retractable bollards are generally deployed to provide vehicle management for secure areas. Road blockers rise from road level, form a solid barrier and will not allow a vehicle to gain entry or pass by crashing through.
 - 3) *Sliding gates* — Sliding gates may be installed to reinforce vehicle entry points and delineate the property boundary during demonstrations. Sliding gates are quick to deploy and cannot be easily bypassed by pedestrians. These or any other combination of gates shall be installed for any unforeseen eventuality to prevent entry into the complex by vehicles or pedestrians.
- b) *Vehicle screening* — Any method of under vehicle inspection requires regular security officer training and diligence when performing his/her search. Adequate lighting should be provided to screen the vehicle during night. The following options for vehicle screening are available, which should be considered for taking appropriate decision for providing suitable measures:
 - 1) *Undercarriage vehicle surveillance*

- system (UVSS)* — The UVSS provide the operator, through video cameras, with a safe and effective means to search the underside of vehicles for explosives or firearms. The systems are available in fixed or portable units. A UVSS is recommended, however the comparison of vehicle images with a default image is dependent on capability of a security guard. The system can be upgraded to a composite system to include full vehicle search. UVSS with explosive detectors may also be used.
- 2) *Search mirrors* — This method of screening vehicles for an improvised explosive device (IED) is common throughout the country.
 - 3) *Vapour and particle detectors* — Vapour detectors and particle detectors, generally known as sniffers; identify explosives by their particulate or gaseous elements. When used correctly, sniffers can assist in the detection of a range of explosive compositions. The device collects vapour samples through a vacuum as it is run over a package, then analyses them for vapours generated by certain explosives, however, vapour detectors may miss explosives with a low vapour pressure.
 - 4) *Explosive detection trained (sniffer) dogs* — Explosive detection trained dogs (known as sniffer dogs) used in conjunction with search mirrors is another option for screening vehicles.
 - 5) CCTV surveillance to cover the activities of the vehicle entry point is a very important requirement and should be catered in all cases.
 - 6) Suitable means for automatic number plate reading/recording of the vehicle and for capturing image of the driver can also be provided.
 - 7) Speed breakers can include dynamic speed bumps, rumble strips and speed humps to facilitate vehicle screening.
- c) *Car parking* — A car park can be one of buildings busiest and most vulnerable areas. Parking facilities can offer criminals the opportunities to commit personal and property crime without detection. Enhanced security operations in parking areas are supported by intercom systems, emergency phones at strategic locations, duress alarms, CCTV, scream alert detectors and motion detectors in stairwells.
- 1) *Duress/panic alarm stations* — Duress or panic alarms can be placed at strategic locations to enhance public/tenant safety. When the emergency button is activated, the alarm will alert the operator in the control room and emit an audible alarm and/or strobe light.
 - 2) *CCTV* — The placement of cameras shall be done to provide optimum surveillance in all directions including all entry/exit points and cover all dark corners.
 - 3) *Security patrols* — The guard force shall conduct regular patrols of the all car-parking areas. Installing a guard tour system can enhance patrol coverage and effectiveness.
 - 4) *Roller shutters* — Roller shutters can be installed at all vehicle entry points to secure the area when the circumstances dictate.
- d) *Loading bays* — The screening of goods vehicles is difficult and can take time to complete, the size of this development, number of loading bays and expected vehicle traffic in any one day further exasperates the situation. Loading bay has limited space for turning and checking of vehicles. Surveillance measures in form of CCTV cameras should be considered to control and monitor the following:
- 1) Vehicles;
 - 2) Personnel;
 - 3) Goods loading and unloading; and
 - 4) General area.
- e) *Car lift/waiting area in basement* — Basements are vulnerable to vehicle borne explosive devices, theft of vehicles or vehicle parts, theft from vehicles parked in basement, vandalism or damage to vehicle, unauthorized access to basement, damage to car lifts/systems, placement of explosives in lift lobbies or misconduct in lift lobbies. Measures to mitigate these are as under:
- 1) CCTV coverage and regular security patrols.
 - 2) Duress alarm/Panic stations.
 - 3) Roller shutter to secure access to/from the car park.
 - 4) Personnel screening prior to entering shuttle lift by security guards through door frame metal detector (DFMD), hand held metal detector (HHMD)
- f) *Managing of parking bays* — Outside working hours all parking bays should be closed with

roller shutters or sliding shutters secured on the inside. During working hours, the bays should be under the control of a custodian or, where the threat is high, closed with electronically operated shutters which are only opened when the incoming vehicle has been identified and, where necessary, searched.

21.3.4.4 CCTV monitoring

21.3.4.4.1 Security personnel shall,

- a) Be fully trained and conversant in the use of the CCTV equipment on the premises.
- b) All staff responsible for monitoring the CCTV shall be rotated at regular intervals to maintain alertness as defined in recognized industry guidelines.
- c) Any staff overseeing CCTV monitors shall have immediate recourse to other security staff, including emergency/incident control personnel, at all times, to ensure the safe and secure functioning of the premises and their inhabitants and to facilitate the instigation of action as appropriate.
- d) Guidelines for the use and storage of all CCTV footage shall be available to all staff.
- e) Any recording material shall be kept in a fire-proof secure facility to allow immediate access to their contents.
- f) The maintenance of all CCTV recording material shall be kept in good order to enable ready access on an as-needs basis.
- g) All CCTV recording material shall be kept available for review for four weeks.
- h) Log books shall be kept of any incidents requiring investigation/intervention by security staff, and shall be available at all times.

21.3.4.4.2 CCTV control and monitoring

- a) All access areas, such as doorways, lifts and staircases should be covered by CCTV surveillance for both day and night monitoring in large group housing, commercial complexes, hospitals/hotels, airports and railway stations.
- b) The CCTV installation shall be interfaced to the Security Management System (SMS) to provide the operator with the facility to capture and display any camera picture.
- c) Where necessary, cameras shall be provided with pan and tilt control and be fitted with a motorized lens capable of a zoom range (Pan/Tilt/Zoom or PTZ cameras) appropriate to the designated task. Pre-set capability can be provided for all fully functional camera

heads to allow automatic response to adjacent alarms.

All CCTV images shall be recorded. This will provide full flexibility for remote viewing of live and recorded images. The operational requirement of each camera can be stated in terms of monitor and control, detection, recognition or identification.

21.3.4.5 Screening of personnel entering facility

Screening personnel and their belongings at entry points can help reduce the likelihood of explosive devices, weapons and other hazardous or prohibited items or materials being brought into buildings or onto sites. Similarly, searching personnel as they exit can help reduce the risk of unauthorized removal of items and information and acts as deterrent. Appropriate screening and detection equipment can offer real benefits where used in support of robust procedures and well trained and motivated staff.

21.3.4.5.1 Standard operating procedures (SOP)

In order to provide an excellent security service following security procedures should be adhered to across all buildings and SOPs as per the organization's requirement should be formulated to standardize the processes:

- a) Access control;
- b) Identification badge;
- c) Administration of locks and keys;
- d) Sites' opening and closing procedures;
- e) Security risk, threat and violation;
- f) Card access system;
- g) Search procedures;
- h) Managing the security control room;
- j) Incident management and investigation;
- k) Reporting of security incidents and losses;
- m) Asset removal;
- n) Transportation security; and
- p) Site emergency procedures.

21.3.4.5.2 Perimeter and landscaping

Perimeter forms an important part of security environment of any complex or asset. Landscaping shall lend itself to strengthen the security instead of creating a hurdle in securing the area. Some of the measures recommended are as under:

- a) Perimeter protection through a wall/fence and barriers with adequate height to deter intrusion.
- b) Physical and electronic measures to cordon the complex, when desired.

- c) Surveillance of perimeter including intruder detection system and quick response from security.
- d) Regular patrolling by security.
- e) Provision of armed guards for limited defending capability against armed intruders.
- f) All plants and trees to be kept trimmed to minimise the opportunity of concealment and/or assistance for intruders to unlawfully enter facility.
- g) Allocate public space to provide natural barriers to prevent easy targeting for bag snatchers.
- h) All plants and trees to be kept trimmed to minimise the opportunity of concealment of improvised explosive device (IED).
- j) Provision of good perimeter lighting.
- k) Adequate CCTV coverage that will deter, detect and record incidents of concern to the client.

Perimeter landscaping including plants, trees, shrubs, ditches and berms (low earth walls used to provide blast protection) should be constructed, located and maintained to stop, deter and/or delay an intruder. Landscaping shall not provide cover for surprise attacks on persons, and shall not permit entry or a climbing aid. Landscaping shall not obstruct lines of sight, lighting, and CCTV or intrusion detection systems.

Fountains, pools, pieces of sculpture, sizeable boulders, stairs reinforced and anchored benches, concrete planters and bollards strategically placed near a building can be used to deny vehicle access to vulnerable areas and maintain a spatial separation of vehicles from a buildings structure.

21.3.4.5.3 Service entry/exit

These areas are vulnerable to unauthorized entry/exit, loitering in premises/landscaped area by anti-social elements and also forced entry by unauthorized vehicle. Some of the measures for securing these should be as below:

- a) Install sliding gates at the service entrance.
- b) Use the gates at night to restrict access.
- c) Create the impression of a 'hard target'.
- d) Adequate lighting of building perimeter.

21.3.4.5.4 Pedestrian entrance/exit

Entry of pedestrians is another major threat to the asset. Strict security measures shall be implemented to secure the asset from entry of persons into the complex. Pedestrian entry points can be used for unauthorized access of anti-national or anti-social personnel, smuggling of arms, ammunition, explosives and

contraband, placement of IEDs or other fire arms/ explosives within premises, removal or theft of items/ articles of value, commit criminal activity, unauthorized reconnaissance or surveillance of premises. Mitigation measures recommended:

- a) Mandatory display of ID cards by employees.
- b) All non-employees guided to pedestrian lane.
 - 1) All visitors to be asked to report to the reception desk.
 - 2) Personnel security screening checkpoint
 - 3) Visitor registration and issue of photo ID badge.
 - 4) Screening of only visitors through Hand Held Metal Detector (HHMD) and Door Frame Metal Detector (DFMD).
 - 5) Checking of visitor's baggage by X-ray scanners.
 - 6) Random checking of employee bags.
 - 7) All employees to pass through flap barrier/ turnstiles placed at lift lobby and escalator base landing by using their access cards.
 - 8) Separate turnstile lane needed for visitors and handicapped persons.
 - 9) Stairwells should provide egress only from a floor; all ground level doors should be fitted with panic bars and monitored by security/installation of electronic access control lock.

21.3.4.5.5 Mail and courier handling

Mails can be a source for sending letter bombs. Letter can also be used for delivery of biological/chemical contaminants. Mitigation measures recommended for prevention of threats from letter bombs can be:

- a) Isolation of mail delivery area, that is, mail room;
- b) Screening of mail by X-ray scanner, explosive detector (*see Note*);
- c) Access control and intruder detection for critical plant rooms, like, BMS, DG room, UPS room, LT Panel, water treatment plant (WTP), AHU, etc.

NOTE — Mail detection devices represent one layer of defence and will not detect every type of explosive material. Detection technologies employed should meet very specific needs. Blast containers should be provided to hold suspect mail, which can be identified and dealt with by the Bomb Detection and Disposal Squad (BDDS) of the police.

21.3.4.5.6 Glazing

- a) Most glazing materials and components designed to respond to blast loads will be damaged by the blast overpressures. To

improve the post-damage behaviour of the glazing system, laminated glass is the preferred choice. The minimum overall thickness of laminated glass classed as blast resistant should be designed considering the impact which shall include a polyvinyl butyl (PVB) interlayer of minimum thickness of 1.5 mm.

- b) Equally important to the design of the glass is the design of the window frames. For the window to properly fail, the glass shall be held in place long enough to fail. The capacity of the frame system to resist blast loading should therefore exceed the corresponding capacity of the glazing. Finally a glazing and mullion system designed to resist a specified blast load shall be anchored to an adequately designed building wall system. This building skin shall be capable of resisting not only a reflected shock wave but also reactions transferred from the blast resistant glazing system.

21.3.4.5.7 Door sets

- a) Door sets should be securely fixed into a structural opening of wall construction that shall at least be equivalent strength to the door.
- b) *External secure area doors* — External door sets should be sufficiently strong to resist manual attack from assailants with tools, and the locking system should be multi-point bolting with hinges protected by hinge bolts and resistance against levering. External emergency escape doors: Emergency escape doors should be sufficiently strong to resist manual attack from assailants and the locking system should be resistant against levering.

21.3.4.5.8 Security lighting

The following areas should be illuminated to provide enhanced security:

- a) Perimeter roads;
- b) Public spaces;
- c) Areas immediately surrounding buildings;
- d) Pedestrian walkways/routes; and
- e) Car parks.

21.3.4.5.9 Blast resistant trash bins

Blast mitigation trash receptacles enhance public safety from terrorist bombs planted inside public trash receptacles. These blast mitigation bomb receptacles are typically used at airports, train stations, sports stadiums, and malls.

21.3.4.5.10 Baggage inspection

X-ray scanners have either a fan shaped or scanning X-ray beam that is transmitted through the object to be viewed. Simple X-ray machines rely on humans to serve as pattern recognition devices; in the absence of computer pattern recognition techniques they are very dependent on human factors such as training and competency of the screener.

21.3.4.5.11 Lift lobby level access turnstiles or panel gates

These are designed to provide a means of access control in busy office/lift lobby entrances. The gates function in either an open position that closes the lane in the event of an unauthorized access, or in a closed position that opens the lane for authorized passage. Flap barrier type turnstiles/panel gates are recommended.

21.3.4.5.12 Electronic security systems

Electronic security systems provide a control, monitoring, and detection and surveillance capability. Electronic systems are interfaced with physical barriers such as doors, gates and turnstiles. Electronic systems need to be integrated in to a security management system (SMS). The SMS will provide the necessary capabilities to monitor control and manage the security systems.

21.3.4.5.13 Fire detection and alarm system interface

The SMS can interface with the fire detection and alarm system. The interface will operate such that, upon the activation of the fire alarm system, the access control system (ACS) controlled door locks, which are designated to operate in a fail-safe mode and release open, shall be de-energized. ACS controlled doors to high security areas, such as computer rooms, will be designated to fail-secure in a fire alarm condition.

21.3.4.5.14 Access control system (ACS)

A fundamental element in the security strategy is to prevent unauthorized access to restricted areas and, subsequently, to control and monitor the movement of authorized persons within the buildings. This shall be implemented in a manner, which does not inhibit operations.

The system should operate as an integral sub-system of the SMS. The proposed system should utilize the latest developments in access control technology and should be based on proximity card reading technology. The system should limit the ability of individuals without authorization to pass through 'locked' doors based on the time of the day, day of the week, week of the year and the authorization levels allocated to the individual.

Proximity technology which is extremely ‘user friendly’ may be used with advantage. The card is not subjected to any form of mechanical wear and the life expectancy of the card is considerable.

All high security areas within the building shall be provided with an appropriate level of access control technology. Personnel traffic shall be monitored and access to individual floors and specific areas within each floor shall be strictly controlled, as appropriate, by use of the ACS.

21.3.4.5.15 Guard room

A guard room serves administrative purpose which cannot be carried out from the security control room (SCR), namely:

- a) Security management and shift supervision;
- b) Radio communications and charging; and
- c) Provide a centralized point for security issues and tenant concerns.

21.3.4.5.16 Guard tour system

The safety and operational efficiency of the security guard force is critical to the overall security strategy as is the correct and proper patrolling of all external and internal areas. The proposed system will be wireless and operate as an integral sub-system of the access control installation and all patrols details will be displayed on the SMS graphics floor plan. Guard tour radio frequency identification (RFID) tokens presented at designated readers shall be logged and time stamped such that printouts and reviews can be attained of individual Guard tour route.

21.3.4.6 Miscellaneous systems

21.3.4.6.1 Truck screening

Fixed screening devices allows the user to inspect the contents of cargo containers and vehicles quickly and easily, validate manifests in minutes, and pinpoint weapons, explosives, drugs and other security threats. While vehicles and containers remain stationary, the gantry-mounted X-ray and detectors pass over the object being inspected. A dedicated truck screening system is not recommended.

21.3.4.6.2 Keys

To maintain the security of the buildings and areas, the keys and cylinders to the entrance points should be obtained under a key registration system where the keys and cylinders can only be obtained from a nominated manufacturer when the order is approved by an authorized person – usually the department/security manager. Keys should be kept in secure key cabinets where authorized persons only draw them. The key cabinet and key allocation should be controlled using

a key management system. The loss or suspected compromise of a security key shall be reported immediately to the Security Manager.

21.3.4.6.3 Radio communications

It is recommended that an efficient and well organized communication network should be created to pass information as and when necessary.

21.3.4.7 Methodology

Like other services security services can also be carried out by deploying guards by having them on regular rolls of owner/occupant or can be out sourced to specialized agencies. Detailed guidelines on roles/responsibility/qualification of personnel deployed on security details have been prescribed by Law. For all major complexes and sensitive buildings compliance to *The Private Security Agencies (Regulation) Act, 2005* shall be ensured as per the directions of the Authority.

22 SOLID WASTE MANAGEMENT

The requirements for waste management in buildings applicable to all large/small facilities that generate, store, or handle any type/quantity of waste are covered in **22.1** to **22.4**. Waste management of townships, etc, are not covered.

22.1 Principles

Following should be the guiding principle for solid waste management:

- a) Minimise waste generation;
- b) Reuse and recycling of waste;
- c) Waste segregation; and
- d) Waste disposal.

22.2 Solid Waste Management Planning

Facilities that generate waste should categorize their waste according to composition, source, types of wastes produced, generation rates, or according to local regulatory requirements. Effective planning and implementation of waste management strategies should include,

- a) review of new waste sources during planning, siting, and design activities, including during equipment modifications and process alterations, to identify expected waste generation, pollution prevention opportunities, and necessary treatment, storage, and disposal infrastructure.
- b) collection of data and information about the process and waste streams in existing facilities, including characterization of waste streams by type, quantities, and potential use/disposition.
- c) establishment of priorities based on a risk

analysis that takes into account the potential environmental, health and safety (EHS) risks during the waste cycle and the availability of infrastructure to manage the waste in an environmentally sound manner.

- d) identify opportunities for at source reduction, as well as reuse and recycling
- e) detail procedures and operational controls for onsite storage.
- f) definition of options/procedures/operational controls for treatment and final disposal.

22.2.1 Waste Prevention Strategy

Processes should be designed and operated to prevent, or minimise, the quantities of wastes generated and hazards associated with the wastes generated in accordance with the following strategy:

- a) Substituting raw materials or inputs with less hazardous or toxic materials, or with those where processing generates lower waste volumes.
- b) Applying manufacturing process that convert materials efficiently, providing higher product output yields, including modification of design of the production process, operating conditions, and process controls.
- c) Instituting good housekeeping and operating practices, including inventory control to reduce the amount of waste resulting from materials that are out-of-date, off specification, contaminated, damaged, or excess to building/equipment/plant needs.
- d) Instituting procurement measures that recognize opportunities to return usable materials such as containers and which prevents the over ordering of materials.
- e) Minimizing hazardous waste generation by implementing stringent waste segregation to prevent the commingling of non-hazardous and hazardous waste to be managed

22.2.2 Recycling and Reuse

In addition to the implementation of waste prevention strategies, the total amount of waste may be significantly reduced through the implementation of recycling plans, which should consider the following elements:

- a) Evaluation of waste production processes and identification of potentially recyclable materials.
- b) Identification and recycling of products that can be reintroduced into the manufacturing

process or industrial activity at the site.

- c) Investigation of external markets for recycling by other industrial processing operations located in the neighbourhood or region of the facility (for example, waste exchange).
- d) Establishing recycling objectives and formal tracking of waste generation and recycling rates.
- e) Providing training and incentives to employees in order to meet above objectives.

22.2.3 Treatment and Disposal

If waste materials are still generated after the implementation of feasible waste prevention, reduction, reuse, recovery and recycling measures, waste materials should be treated and disposed of and all measures should be taken to avoid potential impacts to human health and the environment. Selected management approaches should be consistent with the characteristics of the waste and local regulations, and may include one or more of the following:

- a) On-site or off-site biological, chemical, or physical treatment of the waste material to render it non-hazardous prior to final disposal.
- b) Treatment or disposal at permitted facilities specially designed to receive the waste. Examples may include: composting operations for organic non-hazardous wastes; properly designed, permitted and operated landfills or incinerators designed for the respective type of waste; or other methods known to be effective in the safe, final disposal of waste materials such as bioremediation.

22.2.4 Every solid waste generated [except industrial waste, hazardous waste, hazardous chemicals, bio medical wastes, e-waste, lead acid batteries and radioactive waste, that are covered under separate rules framed under the *Environment (Protection) Act, 1986*] shall be managed in accordance with the *Solid Waste Management Rules, 2016*.

22.3 Construction and Demolition Waste Management

Every waste resulting from construction, re-modeling, repair and demolition of any civil structure of individual or organization shall be managed in accordance with the *Construction and Demolition Waste Management Rules, 2016*.

22.4 Hazardous Waste Management

Hazardous wastes should always be segregated from non-hazardous wastes. If generation of hazardous waste

cannot be prevented through the implementation of the general waste management practices (*see 22.2*), its management should focus on the prevention of harm to health, safety, and the environment, according to the following additional principles:

- a) Understanding potential impacts and risks associated with the management of any generated hazardous waste during its complete life cycle.
- b) Ensuring that contractors handling, treating, and disposing of hazardous waste are competent enterprises, and following good industry practice for the waste being handled.

The management of hazardous and other wastes as specified in the schedules to *Hazardous and Other Wastes (Management and Transboundary Movement) Rules, 2016* shall be done in accordance with the said rules.

22.5 Plastic Waste Management

The plastic waste generated in the premises shall be managed in accordance with the *Plastic Waste Management Rules, 2016*.

22.6 Bio-medical Waste and E-Waste Management

22.6.1 All bio-medical wastes generated in the premises shall be disposed strictly in accordance with the *Bio-Medical Waste Management Rules, 2016* as may be applicable. Utmost care should be taken to ensure that this does not get mixed with other types of waste. Disposal should be segregated and stored in closed bins, carrying appropriate markings, which should be colour coded as prescribed in the statutory rules only in designated and suitably designed and protected areas till they are removed through and to authorized waste treatment facilities

22.6.2 E-waste generated shall also be disposed of as per *E-Waste (Management) Rules, 2016* and to authorized e-waste recycling and disposing facilities.

22.6.3 Proper documentation shall be maintained in all such cases in formats as may be prescribed by the concerned authorities.

23 BUILDING MANAGEMENT SYSTEMS (BMS)

23.1 Overview

All buildings have some form of mechanical and electrical services in order to provide the facilities necessary for maintaining a comfortable working environment. These services have to be controlled by some means to ensure, availability of facilities as designed and comfort conditions irrespective of the number of occupants or individual preferences. Basic controls take the form of manual switching, time clocks

or temperature switches that provide the on and off signals for enabling pumps, fans or valves, etc. The purpose of a building management system (BMS) is to automate and take control of these operations in the most efficient way possible for the occupiers/business, within the constraints of the installed plants/installations.

The BMS is a 'stand alone' computer system that can calculate the pre-set requirements of the building and control the connected plant to meet those needs. Its inputs, such as temperature sensors and outputs, such as on/off signals are connected into outstations around the building. Programmes within these outstations use this information to decide the necessary level of applied control. The outstations are linked together and information can be passed from one to another. In addition, a modem can also be connected to the system to allow remote access. The level of control *via* the BMS is dependent upon the information received from its sensors and the way in which its programmes tell it to respond to that information. In addition to offering a precise degree of control to its environment, it can also be made to raise alarm on conditions that can't meet specification or warn of individual items of plant failure.

Occupancy times for different areas are programmed into the BMS such that the facilities are brought on and off to meet the occupier requirements. BMS determines the plant start time based on the outside air temperature, the space temperature and the building structure.

BMS can control the following key operations:

- a) HVAC systems, which include air handling units, fan coil units, chillers, pumps and boilers;
- b) Lifts (it is normally used to gather information about location/movement of lifts rather than actually controlling their operation);
- c) All equipment having variable frequency drives (VFD);
- d) Lighting systems;
- e) Water supply systems including boilers, water treatment plants, water supply pumps, etc;
- f) Sewage treatment plant (STP), effluent treatment plants (ETP);
- g) Medical and other gas supply system; and
- h) Access control system;
- j) Ventilation system;
- k) Fire alarm and suppression, fire fighting systems (Sprinklers, hydrants); and
- m) CCTV cameras connected to digital video recorders (DVR) or network video recorders (NVR).

Where a BMS or equivalent arrangement exists for monitoring and controlling mechanical, electrical or other engineering installations, an organization should ensure that the requirements for the maintenance of the BMS are fully incorporated into maintenance programmes. In the event of actuator failures or other faults, corrective actions should be initiated with minimal delay.

23.2 Key Components of BMS

BMS is an intelligent mix of hardware devices which works as data collecting/ warning agents and software which collates data and graphically presents same for better and simple understanding. The following are the key components of BMS:

- a) Centralized workstation computer with user friendly software used for everyday building operations;
- b) Direct digital controllers (DDC) – micro-processor based pre-configured/freely programmable controllers; and
- c) Field devices – temperature sensors, humidity sensors, pressure sensors, valves, actuators, movement sensors, etc.

23.3 Responsibilities Relating to BMS

23.3.1 Responsibility of Facility Manager

- a) To operate and manage BMS systems, identify faults, and provide the required reports for the tenant, building owner and building maintenance team.
- b) Adequate monitoring, zoning, scheduling so as to enable the building to operate at maximum possible energy efficiency consistent with tenant lease provisions.

23.3.2 Occupants Responsibility

- a) Providing accurate and detailed information on equipment loads.
- b) Providing a detailed schedule on occupation and equipment loads of tenanted areas.
- c) Early advice on changes to usage of tenanted areas.
- d) Vetting staff requests for system adjustments to ensure energy impacts are considered.

23.3.3 Maintenance Team Responsibility

- a) Daily monitoring of the BMS for faults and exceptions relating plant and equipment.
- b) Maintenance of the BMS.
- c) Management of temporary or permanent adjustments to control parameters in accord with lease provisions.

- d) Ensure timely BMS software and hardware upgrades.
- e) Manage upgrading of BMS as required by owner and tenants to support changes in space utilization, equipment upgrades, or energy intensity improvement projects.
- f) Providing timely and accurate advice and reports.

23.4 Good Practices

23.4.1 Mechanical Services

The software should preferably be optimized for start and stop schedules. Rather than starting to pre-condition a building at a set time, each zone may start just in time to reach minimum set condition as occupants start to arrive. For example, a hot summer's night may need an extra hour of air flow compared to a milder night. This typically means that energy requirements for heating and cooling greater will be extended, on average, by several hours per day. For example, many buildings provide full heating and cooling up to 5:30 or 6:00 pm. In well-built and insulated buildings, chillers and boilers can turn off at 4:00 pm or earlier, and still ambient conditions can remain within agreed temperature parameters for 2 h or more utilizing the heating or cooling energy within the water loops.

BMS should have the following:

- a) Provision for automated seasonal temperature adjustment enabling lowering set point temperature at low temperatures and gradually raising through the seasons, giving savings.
- b) Remote alarming system.
- c) Secure remote access as agreed for fault response, diagnosis, and tenant emergency need.
- d) Scheduling calendar so as to be able to check and adjust for daylight saving including for requirements specific to various events, which can be adjusted without programming skills. For example, shutting down unoccupied zones or temporarily varying working hours.
- e) Occupancy sensors; many areas have minimal occupancy at any time or highly variable loads such as conference rooms. In such cases, it may be appropriate to provide minimal conditioned air during normal hours, and ramp up only when space is fully occupied (Ramp up can sometimes be most effectively provided by standalone units to avoid oversizing the central plant to respond to low frequency situation.).

Following safeguards should be followed:

- a) Ensure sensors are correctly located. Sensors should be at the correct height, not above heat generating equipment, or hidden behind office fit-out, within supply air flow, or where external events can affect. For example, a thermostat mounted on an external wall shall be insulated from the wall cavity, or it will read cold in winter, and hot in summer. A thermostat used as a coat rack will have a delay in registering actual room temperature. A thermostat above a photo copier may consistently read four degrees higher than actual temperature when copier is at full power to correct temperature when it is in sleep mode.
- b) Frequent calibration of sensors may be required. While many modern sensors do not suffer accuracy drift over time, a base line error of up to 1° can occur. Calibration will ensure that BMS utilize a true reading at all times.

23.4.2 Electrical Services

Software may be programmed to ensure sensors are activated to provide required illumination controls in following ways to effect efficiency and economy:

- a) Lighting is controlled in zones generally of 100 m² area (unless special circumstances exist) by occupancy sensors. Fire exit stairs on occupancy sensors with automatic override to full lighting during fire alarm events.
- b) Car park daylight adaptation lighting to be dual dimmer controlled by photoelectric (PE) cell and occupancy sensors.
- c) Car park lighting to have two stage occupancy sensor control covering normal and out of hours lighting levels.
- d) Perimeter office zones to have PE cells operating dimmer controls in addition to occupancy sensors.
- e) Entry lobbies to revert to occupancy sensor control outside of operating hours.
- f) General security lighting to minimum level required by security cameras. With modern cameras this is very low and less than what human eye requires.
- g) Responsive security lighting to be event activated with time controlled manual override for emergency situations.
- h) Metering of equipment and zones to be integrated through BMS to required reports.
- j) Lift operation to be optimized *via* intelligent lift controllers, with activity and consumption reports to BMS.

23.4.3 Hydraulics

- a) Meters to report to BMS (number shall enable excess consumption to system or zone).
- b) Temperature optimization control of boilers, by control strategy.
- c) Flow meters to alarm on abnormal consumption.
- d) Boiler temperature reset optimization, to match actual and predicted loads.
- e) Automated shut down valves in critical areas to avoid waste and damage from major failure, with BMS over ride function.

23.4.4 BMS Configuration Active Point Control

- a) Shall default to safe condition on failure and trigger alarm.
- b) Points to be actively interrogated on status to ensure they are operating and reporting.
- c) Point trending and graphing to be flexible and comprehensive.
- d) Demand limiting algorithm in place and load shedding if indicated.
- e) Alarms have priorities set to at least three levels, are placed in permanent file, with name of operator who responded to alarm. Archive of this information should be permitted only to a person with highest authority level, and only when record is over one year old.

23.4.5 Graphics and User Interface

- a) To clearly present data required to check status of system or sub-system without clutter and in logical visual presentation.
- b) Navigation from a graphic page either up to a system overview or down to sub-unit or point history to be intuitive, point and click.
- c) Graphics available of all systems and sub-systems.
- d) Temporary trend graphics able to be set up by all users, and not require high level skills or access.
- e) A full set of reports is configured to enable effective management of system and building.
- f) Four level or equivalent user authorization level control: programmer, system controller, maintenance staff, tenants.
- g) Simple click and point to data, graphics, and agreed control functions of each user.

23.5 Documents Required

Most of the data and reports are stored hence no documents are required except for the works which requires manual interface, for example, maintaining

contacts with appropriate maintenance personnel, logs of maintenance, roaster log, etc.

24 INFORMATION MANAGEMENT

24.1 General

Records and documents relating to the maintenance of the facility should be organized, kept up-to-date and stored in a secure environment.

The following general information should be recorded:

- a) *Classification* — The facility and its sub-divisions (that is, rooms and other spaces) should be assigned codes according to type or use to support the management of information and data;
- b) Obligations under conditions of lease or occupancy (for example, frequency of repainting);
- c) Statutory and insurance inspections;
- d) Estate terrier (records of property holdings with legal status);
- e) Ownership of and/or maintenance obligations of parties, separating and boundary walls;
- f) Rights of way, easements and way-leaves (particularly with respect to buried utilities); and
- g) Requirements and restrictions laid down by planning, building regulation control and fire authorities including, in the case of the latter, fire risk assessments.

Elements/sub-elements of the facility should be labelled or marked, as far as is practicable, so that the materials, components, systems, plant, equipment and parts can be easily identified. Where information is limited or lacking, records should be compiled during maintenance. Alternative (or additional) surveys or investigations should be initiated to accelerate the gathering of information for record purposes; photographic records can be of assistance in this respect.

All personnel involved in the maintenance of the asset/facility should be made aware of the existence of records containing information about it. Hazardous areas should be explicitly marked on the records as well as marked in their physical location/site and should be made known to personnel, together with any system of work adopted for use in these areas.

24.2 Documentation

Good records can save owners and users/occupiers from much unnecessary expense and reduce potential hazards in exploration work, when faults arise. Records are of value only if they are kept up to date and arrangements for this should be included in any

provision that may be made for records.

Records may be broadly classified as following:

- a) ‘As built’ information, which should have been prepared before the handover of the facility, such as construction details, floor plans, perspectives and as-built drawings showing the location of engineering installations and structural details; and
- b) ‘As subsequently altered’, which need to be kept during the operational life of the facility, such as details of defects, maintenance, alterations and redecoration work.

A record should be kept of all reported defects and the measures taken to rectify them. Details of maintenance should also be recorded and cross-referenced to the reported defect.

Periodic reviews of records should be made and where there are recurrences of the same defect, the causes should be investigated.

24.2.1 Facility Handbook

A facility handbook should be prepared as a compilation of records of the asset/facility, which can be stored and retrieved electronically, as well as being reproduced on paper wherever necessary. The form of the handbook should be such that content can be easily updated and future versions of it to be controlled. The handbook should include the records relating to the maintenance of the facility and the documents to support the wider needs of the organization in regard to its facilities management.

Following should be typical contents of the facility handbook:

- a) A brief history of property, names and addresses of consultants and contractors.
- b) Short specifications, constructional processes, components, material finishes, hidden features, special features, etc.
- c) ‘As built’ plans and as subsequently altered with sections, elevations and other detailed drawings.
- d) Foundation and structural plans/sections such as concrete reinforcement drawings.
- e) Detailed specification of all materials incorporated, for example, concrete mix, species and grades of timber, etc. Potentially hazardous materials and types or methods of construction that under some circumstances may become hazardous may be identified.
- f) Information on house keeping and routine maintenance with details of internal and

- external surfaces and decorations, schedule of cleaning, inspection and maintenance.
- g) Information on accessibility features of the building that makes it friendly to users with disabilities and elders.
 - h) Means of operating mechanical, electrical and plumbing installations.
 - j) Description of renovations, extensions, adaptations and repair to each elements.
 - k) All plant, machinery and propriety articles including manufacturers trade literature and instructions for installation, use and maintenance.
 - m) Methods of work used in construction such as assembly of prefabricated units.
 - n) All information related to fire such as,
 - 1) location and service arrangements of all fire alarm and call points;
 - 2) location and service arrangements of all extinguishers, hose reels and other fire fighting installations;
 - 3) location of all fire compartment walls, doors, floors and screens;
 - 4) location of all areas of exceptional fire hazard;
 - 5) fire escape routes;
 - 6) details of application of any fire protection treatment; and
 - 7) location details and description of any installation for smoke control or protection of escape routes.
 - p) There should be a wall chart showing at a glance the various operations which have to be undertaken. Line drawings of buildings are always useful.
 - q) Records of security measures should be known to authorized personnel only.
 - r) Where no records exist, information should be slowly built up as it becomes available during the course of maintenance work.
 - s) Use of computers for storing information may be preferred.

24.2.1.1 Drawings

The records of the facility should include as-built and as subsequently altered drawings [see 24.2.1 (c)] and contain, as a minimum, the following:

- a) A neighborhood plan, showing the position of the facility and the site upon which it is located in relation to its surroundings;
- b) The site plan, showing the facility and other structures forming the facility and external

- engineering installations, for example drainage runs and incoming public utilities;
- c) General arrangement plans of each floor and the roof to a scale not normally greater than 1:50;
- d) Elevations and sections;
- e) Foundation plans and details, together with available soil investigation reports;
- f) Structural plans and sections, including information relating to design parameters, such as permissible superimposed loadings on floors;
- g) Structural details, such as structural steel connections and concrete reinforcement drawings and bending schedules; these are particularly important when prestressed or post-stressed forms of structure have been used;
- h) Details of the construction of external wall elements and roofs, including insulation materials and vapour barriers;
- j) Materials that may be injurious to health and safety;
- k) Location of public health (that is, waste) systems;
- m) Location of essential intake and shut-off of public utilities (water, electricity, gas and telecommunications).
- n) All drawings, including those used in design and construction, should be verified against the as-built facility. Where a discrepancy is found, full details should be recorded and, wherever practicable, the affected drawing(s) should be labelled as subsequently altered.

24.2.1.2 Specifications and schedules

The records of the facility should include detailed specifications of,

- a) all materials incorporated, for example name of facing brick, mix of concrete, species and grade of timber;
- b) materials with properties that can prove injurious to health and safety;
- c) all plant and machinery, including manufacturers' trade literature, manuals and instructions for installation, operation and maintenance; and
- d) methods of work used during construction, which are unusual or a typical, such as assembly of purpose-made manufactured units.

All specifications and schedules, including those used during construction work, should be verified against

the as-built facility. Where a discrepancy is found, full details should be recorded and, wherever practicable, the affected specification(s) and/or schedule(s) should be labelled as subsequently altered.

24.2.2 Asset Register

Asset register is an important document and shall be maintained for each asset and kept updated. Many organizations maintain this as building register for keeping records of their assets and any modifications/alterations done during life time of the asset/facility. An organization should include other information and data as may be necessary in the form of a register of its assets/facility, for example:

- 1) Identification number or unique reference for the asset;
- 2) Location of asset;
- 3) Initial cost;
- 4) Completion cost (component /unit wise if so required);
- 5) Make and/or model;
- 6) Manufacturer for machineries and equipments;
- 7) Vendor, if different to manufacturer;
- 8) Date of manufacture or year of construction for buildings;
- 9) Date of acquisition, installation or completion of construction;
- 10) Details of asset such as area statements, type of structure;
- 11) Whether or not the asset is subject to a permit-to-work requirement;
- 12) Predicted lifetime;
- 13) Specifications;
- 14) Replacement cycle;
- 15) Cost breakdown;
- 16) Servicing requirements, including type and frequency of service;
- 17) Other maintenance required;
- 18) Maintenance costs;
- 19) Accumulated depreciation;
- 20) Written-down value;
- 21) Source of components and spare parts, where applicable;
- 22) Energy consumption and, where applicable, energy efficiency rating; and
- 23) Identification of hazardous or other risks to people or property.

24.2.2.1 Engineering installations

Information describing the facility's engineering installations should be recorded. Details should include

points of entry, or termination, of public utilities.

An organization should stipulate the maintenance requirements for its mechanical and electrical installations and fire protection systems; the tasks to be carried out and their frequency should be included. The following attributes of major components should be taken into account:

- a) Current condition;
- b) Current utilization or output;
- c) Maintenance tasks to be performed;
- d) Frequency of maintenance; and
- e) Estimated cost of maintenance.

24.2.2.1.1 Warranties, repairs and spare parts

Details of warranties relating to plant, equipment, components and systems should be recorded and cross-referenced to those operational and maintenance requirements that affect them. Details of repairs should be recorded against the respective item. A list of spare parts should be kept up-to-date. Details should include the following as a minimum:

- a) Description of part;
- b) Identification number or unique reference for the part;
- c) Original manufacturer of part;
- d) Contact details of current manufacturer and/or distributor;
- e) Predicted lifetime of part;
- f) Operational parameters affecting lifetime of part;
- g) Minimum number of parts to be held in stock (within or near to the facility);
- h) Where permissible, details of any alternative part and its source;
- j) Availability and minimum delivery period;
- k) Warranty period;
- m) Estimated cost of part;
- n) Transportation and logistical considerations;
- p) Details of other parts potentially affected by failure and/or replacement;
- q) Specialist equipment or tools required;
- r) Specific competence required; and
- s) Details of special conditions or arrangements when installing.

The details given in (a) to (s) are, in effect, an inventory that should be kept up-to-date if the organization is to minimise disruption and/or loss of business continuity in the event of a breakdown or failure. An organization should determine its policy on the holding of spare parts.

24.2.2.1.2 Documentation of mechanical records

Documentation should record the following as installed:

- a) Location, including level if buried, of all public service connections (for example, fuel gas and cold water supplies) together with the points of origin and termination, size and materials of pipes, line pressure and other relevant information;
- b) Layout, location and extent of all piped services showing pipe sizes, together with all valves for regulation, isolation and other purposes as well as the results of all balancing, testing and commissioning data;
- c) Location, identity, size and details of all apparatus and all control equipment served by, or associated with, each of the various services together with copies of any test certificates for such apparatus, where appropriate. The information with respect to size and details may be presented in schedule form;
- d) Layout, location and extent of all air ducts showing dampers and other equipment, acoustic silencers, grilles, diffusers or other terminal components. Each duct and each terminal component should be marked with its size, the air quantity flowing and other balancing data; and
- e) Location and identity of each room or space housing plant, machinery or apparatus.

24.2.2.1.3 Drawings for mechanical installations

Drawings should record the following as installed:

- a) Detailed general arrangements of boiler houses, machinery spaces, air handling plant, tank rooms and other plant or apparatus, including the location, identity, size and rating each apparatus, The information with respect to the size and rating can be presented in scheduled form;
- b) Isometric or diagrammatic views of boiler houses, plant rooms, tank rooms and similar machinery, including valve identification charts. It is useful to frame and mount a copy of such drawings on the wall of the appropriate room; and
- c) Comprehensive diagrams that show power wiring and control wiring and/or pneumatic or other control piping including size, type or conductor or piping used and identifying the terminal points of each.

24.2.2.1.4 Electrical installations

Records should be kept of the following as installed:

- a) Main and sub-main cables, showing origin, route, termination, size and type of each cable. Cables providing supplies to specialist equipment, for example data centre equipment, should be identified separately;
- b) Lighting conduits and final sub-circuit cables, showing origin, route, termination and size of each, together with the number and size of cables within each conduit. The drawings should indicate, for each conduit or cable, whether it is run on the surface or concealed, for example in a wall chase, in a floor screed, cast *in-situ* or above a false ceiling. These drawings should also indicate the locations of lighting fittings, distribution boards, switches, draw-in-boxes and point boxes, and should indicate circuitry;
- c) Details of secondary power sources for inclusion in a safe systems of work regime;
- d) Location and purpose of each emergency lighting fitting, including an indication of the circuit to which it is connected;
- e) Single and three-phase power conduits and final sub-circuit cables showing locations of power distribution boards, motors, isolators, starters, remote control units, socket outlets and other associated equipment;
- f) Other miscellaneous equipment, conduits and cables;
- g) Lightning conductor air terminals, conductors, earth electrodes and test clamps;
- h) Location of earth tapes, earth electrodes and test points; and
- j) Cables providing earth circuits for specialist equipment should be identified separately.

Records should also include, where applicable,

- 1) distribution diagrams or schedules to show size, type and length (to within 1 m) of each main and sub-main cable, together with the measured earth continuity resistance of each;
- 2) schedule of lighting fittings installed stating location, manufacturer and type or catalogue number together with the type or manufacturer's reference, voltage and wattage of the lamp installed;
- 3) schedule of escape and emergency lighting fittings installed stating location, manufacturer, type or catalogue number together with the type or manufacturer's reference, voltage and wattage of the lamp installed. For battery systems, the position of the battery, its ampere-hour rating and battery system rated endurance, in hours, should be stated;

- 4) records of smoke detectors, sprinklers and fire precautions generally, as well as security precautions;
- 5) incoming supply details including the type of system, voltage, phases, frequency, rated current and short circuit level, with the details of the supply protection and time of operation as appropriate;
- 6) main switchgear details which, for purpose-made equipment, should include a set of manufacturers' drawings and the site layout;
- 7) transformer, capacitor and power plant details. for example in the case of transformers, the volt-ampere rating, voltages and type of cooling; and
- 8) completion certificate.

All records and drawings, including those used during construction work, should be verified against the as-built facility. Where a discrepancy is found, full details should be recorded and, wherever practicable, the affected record(s) and/or drawing(s) should be labelled as subsequently altered.

24.2.3 Operating and Maintenance Manuals

24.2.3.1 The engineering services within buildings frequently are dynamic, involving complex systems of integrated plant items. Operation of such plant can require detailed knowledge and direction. Maintenance can also require extensive information to be available. It is, therefore, important to have suitable operating and maintenance manuals to provide the necessary guidance. These should be included as part of the contractual requirements for new installations and should ideally be prepared as reference documents for existing installations where no such information exists.

24.2.3.2 Information and data on the operation and maintenance of the facility, including measures to conserve fuel and power, should be incorporated into the O&M manual. The organization should ensure that provisions made in the facility handbook are satisfied.

Preparation of an O&M manual tailored to suit each facility can offer significant advantages in terms of providing a clear statement of intentions and required actions. Depending upon whether one is responsible for the maintenance of a number of facilities or a single facility, the maintenance manual will be designed and prepared.

An organization's procedures for undertaking maintenance should be formalized in a maintenance manual or manuals. The manual may form part of wider documentation covering operational plans and arrangements. In the event of a change of organization or maintenance advisor, an up-to-date manual and

facility handbook should ensure continuity of maintenance. Copies of maintenance manuals should be held by the organization and any maintenance advisor, if appointed.

24.2.3.3 Structure of operation and maintenance manual

The maintenance manual should be prepared in two parts: the first part should be addressed to the organization; and the second part should be addressed to those responsible for inspecting the facility and reporting to and advising the organization.

The first part of the manual should,

- a) Recommend intervals between,
 - 1) routine, general and detailed inspections,
 - 2) inspection and maintenance of each engineering installation and items of special equipment;
 - 3) maintenance of items which, as recommended by their manufacturers, require regular attention to preserve satisfactory performance, for example the lubrication and adjustment of moving parts in component assemblies and systems; and
 - 4) other periodic work as experience in use shows to be necessary, for example the clearing of gutters, downpipes or surface water gullies.
- b) Draw attention to the need to ensure that a facility's provisions for means of escape in the event of fire, that is, fire resisting self-closing doors and exit hatches, are in satisfactory working order at all times, including those periods during which any maintenance is being undertaken.
- c) Draw attention to critical environments, including special arrangements for gaining access for the purpose of inspections or when undertaking maintenance;
- d) Specify proprietary maintenance materials, for example floor sealers and polishes likely to offer acceptable service and slip resistance.
- e) Set out the names, addresses and other contact details of firms responsible for the following:
 - 1) inspecting, reporting and advising on the condition of the building fabric;
 - 2) emergency repairs to the building fabric; and
 - 3) servicing and emergency repairs for each engineering installation and items of special equipment.

The second part of the manual should,

- a) Consist mainly of selected, concise information, abstracted from the facility handbook, and likely to be needed during inspections; this information should be ordered in the sequence in which examination is likely to be carried out.
- b) Schedule those materials and components that experience shows to be prone to failure and/or to require special attention.

24.2.3.4 *Updating of O&M manual*

The maintenance manual should be reviewed annually and updated where necessary, to reflect changes in legislation as well as current circumstances and arrangements. When changes occur to facilities, or where new information becomes available, all copies of the maintenance manual should be revised accordingly, irrespective of whether it is self-standing or forms an integral part of the facility handbook.

24.3 Storage and Security of Records

24.3.1 *General*

An organization should keep records in a safe and secure location and arrange them in such a way as to enable their rapid retrieval. Records of personnel permitted to access the records and any requirements or conditions attaching thereto should be defined.

24.3.2 *Storage*

The place for storage of records should take into account the form of the records, the media used and the conditions necessary to keep them from damage of any kind; they should also be readily accessible. Backup or duplicate records (electronic and paper-based) should be kept in a secure place in a location other than the facility to which they relate. Both sets should be kept up-to-date.

24.3.3 *Security*

Measures taken to ensure security should be recorded and a copy should be held in a secure location away from the facility to which they relate. The following records should be readily accessible to authorized personnel when required, which may be at short notice and outside normal working hours:

- a) Names, home addresses and telephone numbers of key holders;
- b) Details of master key system; and
- c) Details of intruder alarms and other security systems.

24.4 Computerization of Information Management

An organization should review its requirements for data systems, basic information and communication

technology (ICT) facilities and extended services necessary to support its maintenance management. The use of a CAFM or a CMMS as means for managing facility related maintenance information should be evaluated. The following features are likely to provide a suitable basis:

- 1) Budgetary and other financial controls;
- 2) Cost accounting;
- 3) Asset register;
- 4) Condition-based monitoring of assets;
- 5) Early detection of problems and rapid fault reporting;
- 6) Operational plans, including frequency of functions or activities performed;
- 7) Risk and hazard assessment;
- 8) Permits-to-work;
- 9) Personal protective equipment issued and returned;
- 10) Planned preventive maintenance;
- 11) Reactive maintenance;
- 12) Change management;
- 13) Job orders and other requisitions for goods and services;
- 14) Job logging, prioritization and tracking, including details of backlogs;
- 15) Energy use and carbon dioxide (CO₂) equivalent emitted per annum;
- 16) Resource consumption and productivity measures;
- 17) Analysis of work undertaken to identify trends;
- 18) Space planning and space utilization;
- 19) Workstation location and furniture management;
- 20) Performance indicators for the delivery of services;
- 21) End-user experiences of services delivered;
- 22) Audit trail of system transactions; and
- 23) Exception reporting for management purposes.

25 CHECK LISTS

In order that the activities of inspection/maintenance of assets may be carried out systematically in a comprehensive manner, certain check lists/proforma may be made available. While these may vary from asset to asset and organization to organization, a few examples of the activities to be covered are given below:

- a) *Register of buildings* — Initial cost, cost of additions and alterations year-wise. This is required to verify periodically that all assets

- paid for by the organization are kept duly preserved and maintained.
- b) Amount admissible per annum for carrying out maintenance operations related to civil, E&M equipment and establishments, horticulture maintenance works during a year, including,
 - 1) plinth area rates for maintenance works for base year; and
 - 2) maintenance cost index, repair cost index.
 - c) Maintenance norms, frequency of application of finishing items.
 - d) Guidelines for annual maintenance estimates for horticulture works.
 - e) Classification of horticulture maintenance works.
- f) Inspection lists of general buildings:
 - 1) Civil,
 - 2) Electrical, and
 - 3) Horticulture.
 - g) Additional inspection lists for critical buildings:
 - 1) Substation equipment, generating sets, service connection;
 - 2) Air conditioning plants;
 - 3) Electrical installations, lifts, water supply pumps, sewage pumps, filtration plants;
 - 4) Fire alarm, fire fighting;
 - 5) Public address system; and
 - 6) CCTV, cable TV, laundry, kitchen, incinerator, etc.

ANNEX A

(Clause 9.5.3)

COMMON CAUSES FOR MAINTENANCE PROBLEMS

A-1 The major causes for maintenance problems in different elements of a building are discussed in **A-1.1** to **A-1.5**.

A-1.1 Floors

- a) Poor quality of construction which includes quality of construction material and workmanship.
- b) Improper slopes, mainly in kitchen, bathrooms/toilets, etc.
- c) Lack of rounding at junctions of walls with floors.
- d) Lack of damp-proof course treatment in walls and particularly in sunken floors.
- e) Poor design of building.
- f) Improper waterproofing.

A-1.2 Roofs

- a) Inadequate roof slopes.
- b) Inferior quality of construction.
- c) Cracks on roof surfaces.
- d) Inadequate provision of rain water spouts.

- e) Blockages in gratings/rain water pipes.
- f) Worn out felts/membranes.
- g) Bubbling up of tar felt and separation of joints.
- h) Improper water proofing or wrong selection of water proofing technique.
- j) Leakage from the openings provided on the roof.
- k) Improper treatment of expansion/construction joints.
- m) Non providing of *Gola* at junction of parapet and wall and roof.
- n) Improper execution of *Khurra*.
- p) Lack of pre-monsoon inspections

A-1.3 Plumbing

- a) Inadequate slopes in soil/waste pipes.
- b) Improper joints in pipes.
- c) Joints in walls and floors.
- d) Improper junctions of stacks.
- e) Inadequate cleaning eyes at junctions.
- f) Throwing of solid wastes in WC's.

- g) Lack of periodical checking and cleaning.
- j) Lack of motivation/education to users for proper use.
- k) Overflow from service tanks.
- m) Inferior quality of fittings and fixtures.
- n) Inadequate design.

A-1.4 Drainage

- a) Improper surface dressing around buildings and improper upkeep of surroundings.
- b) Growth of wild grass and vegetation.
- c) Inadequate drainage system around the building.

- d) Inadequate slope of the drains or drainage pipes.
- e) Inadequate number of inspection chambers.
- f) Theft of manhole covers, etc.
- g) Throwing of solid waste in the open surface drains.

A-1.5 Electrical

- a) Loose connections.
- b) Improper earthing and earth connections.
- c) Damages to wires, cables and other installations.
- d) Under rated cables/wires and other installations.

ANNEX B
(Clause 9.10.3.6)

FORMAT FOR INSPECTION REPORT

Building/Block:

(A) INSPECTION OF BUILDINGS (CIVIL)									
(a) House No. and Type:					(b) Location:				
(c) Date of Last Inspection:					(d) Date of Present Inspection:				
SI No.	Item No.	Needs Repair			Needs Replacement		Priority		
		Action	Quantity	Cost	Quantity	Cost	Immediate	Annual	Routine Repairs
1.	Walls								
1.1	Cracks								
1.2	Repair to plaster								
1.3	Repair to brick work								
1.4	Dampness								
2.	Floors								
2.1	Cracks								
2.2	Settlement								
2.3	Slopes								
2.4	Skirting cracks								
2.5	Dados cracks								
3.	Doors, Windows, Ventilators and Cupboards								
3.1	Glass panes broken								
3.2	Panels in shutters broken								
3.3	Panels fit improperly								
3.4	Improper/missing fittings								
	3.4.1	Hinges							

	3.4.2	Handles								
	3.4.3	Tower bolts								
	3.4.4	Aldrops								
	3.4.5	Floor door stopper								
	3.4.6	Knobs								
	3.4.7	Cleats								
	3.4.8	Hooks and eyes								
	3.4.9	Curtain rods								
	3.4.10	Stays								
	3.4.11	Pelmets								
4.		Roofs								
4.1		Leakages/damp patches								
4.2		Water proofing treatment								
4.3		<i>Gola</i>								
4.4		<i>Khurra</i>								
4.5		Brick drip course								
4.6		Rain water pipe								
4.7		Regrading								
4.8		Top layer of tiles								
4.9		Parapet, coping								
5.		Water Supply and Sanitary Fittings								
5.1		Leakages in pipe joints								
5.2		Functioning of washers								
5.3		Functioning of traps in fittings								
5.4		Functioning of floor traps								
5.5		Functioning of overhead/low level cistern								
5.6		Air locking								

76

NATIONAL BUILDING CODE OF INDIA 2016

5.7	Leakages in pipe joints								
5.8	Condition of overhead tank								
5.9	Cleaning of overhead tank								
5.10	Fittings								
	5.10.1	Washbasin							
	5.10.2	Soap container							
	5.10.3	Mirror							
	5.10.4	Glass shelf							
	5.10.5	Towel rail							
	5.10.6	Hangers							
	5.10.7	Sinks							
	5.10.8	Taps							
	5.10.9	Pillar cocks							
	5.10.10	Showers							
	5.10.11	Cisterns							
	5.10.12	Ball valves							
	5.10.13	Seat cover							
	5.10.14	Steps							
6.	External Services								
6.1	Manhole covers								
6.2	Covers to gully traps								
6.3	Cleaning of manholes								
6.4	Plinth protection								
6.5	Cleaning of storm water drain								
6.6	Approach roads								
6.7	Service lanes								
7.	Finishing								
7.1	White washing/colour washing/distemper								
	(a)	When was it done last?							

	(b)	When is it due?							
	(c)	Existing condition.							
7.2	Painting								
	(a)	When was it done last?							
	(b)	Existing condition							
	(c)	When is it due?							
8.	Common Areas								
8.1	Railing to staircase								
8.2	Staircase steps								
8.3	Staircase nosing								
8.4	Shafts								
(B) INSPECTION OF BUILDINGS (ELECTRICAL)									
(a) House No. and Type :						(b) Location :			
(c) Date of Last Inspection :						(d) Date of Present Inspection :			
Sl No.	Item No.	Needs Repair			Needs Replacement		Priority		
		Action	Quantity	Cost	Quantity	Cost	Immediate	Annual	Routine Repairs
1.	Switch Boards								
1.1	Regulator								
1.2	Switches								
1.3	Fixing of tiles								
2.	Fans								
2.1	Canopy fixing								
2.2	Speed and noise								
3.	Socket outlet points and connection								
3.1	Tile								

78

3.2	Switch								
3.3	Outlet connection, if any								
4.	Fittings								
4.1	Reflector								
4.2	Louvres/Perspex cover								
4.3	Suspension rod								
5.	Exhaust Fans								
5.1	Speed and noise								
5.2	Louvres								
5.3	Connecting wires including ceiling rose								
6.	Call bells								
6.1	Bell push								
6.2	Connecting wire								
6.3	Bell buzzer								
7.	Sub distribution boards/ BDB/Main Board								
7.1	Switch covers								
7.2	Fuse kit kats								
7.3	Earth connection								
7.4	Fuse rating								
7.5	Inter connection								
7.6	Boards								
(C) INSPECTION OF BUILDINGS/GARDENS									
1.	Lawn:								
1.1	Weeding								
1.2	Patch repair								

NATIONAL BUILDING CODE OF INDIA 2016

1.3	Renovation								
1.4	Regrassing								
2.	Hedge:								
2.1	Gap filling								
2.2	Replacement								
3.	Pruning and Training:								
3.1	Naturally required pruning								
3.2	Pruning required for security purpose of building as well as occupant								
4.	Planting Beds:								
4.1	Needs replacement								
4.2	Gap filling								
5.	U/F Water Supply:								
5.1	Matter to be reported to U/F water division after inspection								
6.	Rockerries:								
6.1	Gap filling of dead one								
6.2	Replacement of damaged, weak								
6.3	Replacement of stones								
6.4	Thinning, trimming								
6.5	Redesigning of paths, maintenance of paths								
7.	Kitchen Garden:								
7.1	Change in site								
7.2	Plan for planting of vegetables								

80

8.	Road Side Plantation:								
8.1	Gap filling Nos.								
8.2	Trimming, pruning								
8.3	Tree guards not required and to be removed/repair/painting, etc								
8.4	Proposal for new plantation, digging of holes, etc								
8.5	Miscellaneous								
8.6	MOU-Detailed report (Performance and financial achievements)								

NATIONAL BUILDING CODE OF INDIA 2016

ANNEX C

(Clause 9.11.1.1)

TYPICAL NORMS FOR EMPLOYMENT OF WORKMEN FOR DAY-TO-DAY MAINTENANCE OF BUILDINGS

C-1 Building maintenance is known to be most labour intensive of the construction industry.

C-2 CIVIL WORKS

Maintenance staff is required for day-to-day maintenance of buildings. The work of carrying out annual repairs to buildings, like white/colour washing, distempering, emulsion painting, enamel paint/polish, etc, works of additions and alternations or minor works not requiring immediate execution are normally not covered in their duties and may be got done through contractors. However, spare capacity, if any, should be utilized in carrying out petty items of works.

C-2.1 Norms for Employment of Workmen

The general norms for employment of workmen for civil works in building is given in Table 1.

C-3 ELECTRICAL ENGINEERING WORKS

C-3.1 Day-to-Day Maintenance

For electrical engineering works, maintenance staff is generally employed on routine maintenance works of internal wiring. Maintenance and repair work of specialized and complicated nature are not covered. The yardsticks given in Table 1 indicate the workmen normally required for day-to-day maintenance of electrical works.

C-3.2 For electrical installations, only the electrician/wireman/assistant wireman holding the valid permit/licence issued by the electrical inspectorate/state administration (of the respective state in which work is to be carried out) shall be deputed on work.

Table 1 General Norms for Employment of Workmen
(Clauses C-2.1 and C-3.1)

Sl No.	Categories	Number	Residential Buildings	Non-Residential Buildings	Remarks
(1)	(2)	(3)	(4)	(5)	(6)
i)	Civil categories ¹⁾ :		Plinth area, in m ² , for which admissible		
	a) Mason	1	25 000	30 000	For public buildings, such as airports, hospitals and hotels, norms will depend upon the facilities and specific requirements
	b) Carpenter	1	30 000	50 000	
	c) Plumber	1	30 000	36 000	
	d) Sewerman	1	30 000	60 000	
	e) Shramik/Beldar		One beldar for each carpenter and mason. Additional as per work requirement	Twice the number of workers in category of mason and carpenter	
ii)	Electrical categories:		No. of points for which one person is required		
	a) Wireman	1	3 300	3 300	For public buildings, such as airports, hospitals and hotels, norms will depend upon the facilities and specific requirements
	b) Khallasi ²⁾	1	6 600	6 600	
NOTES					
1 These norms are for government buildings where change of users is very often and permanent staff is required on account of sensitivity of users.					
2 Actual requirements will depend upon type of structure, its usage and complexity/importance and level of maintenance required.					
3 Requirement of other category of maintenance and operational staff will depend upon the type and usage of the facility.					
¹⁾ Number of workmen indicated is where engagement is considered desirable on regular basis for entire year. Night duty staff not included in this norm.					
²⁾ One khallasi for two wiremen.					

ANNEX D
(Clause 11.10.3.3)

METHODS OF OPERATIONAL CHECKS FOR STP

D-1 CODE AND METHOD OF CHECKING

<i>Sl No.</i>	<i>Code</i>	<i>Method</i>	<i>How to Check</i>
(1)	(2)	(3)	(4)
i)	V	Visual	Check for presence (or absence) of the indicated feature
ii)	M	Measurement	Measure the indicated dimensions and compare against specified limits
iii)	T	Performance test	Conduct a test and compare the results against the specified limits
iv)	D	Documentation check	Check in drawings and calculations (typically for aspects that cannot be checked with visual inspection or other testing methods)

D-2 BAR SCREEN CHAMBER

<i>Sl No.</i>	<i>Check</i>	<i>Acceptance Criteria</i>	<i>Method</i>	<i>Rationale</i>
(1)	(2)	(3)	(4)	(5)
i)	Working on platform	a) Observe the operator as he collects debris	T	If the debris-collection is not comfortable, it will stop in a few days; leading to a clogged and dysfunctional bar screen chamber
		b) Posture is normal during working		
		c) Does not have to balance on platform		
		d) Can see the whole chamber easily		
		e) Not facing any difficulty		
		f) Can easily reach the grill and floor		
		g) No struggle to remove parts stuck in grill		
ii)	Handling of debris	a) Observe the operator as he disposes off debris	T	Disposal of debris shall be easy and hygienic
		b) Operator can easily use the platform (or a basket) to let the debris drip dry		
		c) Operator can easily place the collected debris into a garbage bag		

D-3 EQUALIZATION TANK

<i>Sl No.</i>	<i>Check</i>	<i>Acceptance Criteria</i>	<i>Method</i>	<i>Rationale</i>
(1)	(2)	(3)	(4)	(5)
i)	Actual level fluctuations	Check for overflows – tell-tale colouration on side walls/freeboard	M	To determine if equalization tank size is adequate to handle peak inflows

<i>Sl No.</i> (1)	<i>Check</i> (2)	<i>Acceptance Criteria</i> (3)	<i>Method</i> (4)	<i>Rationale</i> (5)
ii)	Aeration and mixing	a) Bubbles rise across the entire surface of the aeration tank (no dead zone in any area, especially edges and corners) b) There is no odour c) There is no localized violent bubbling/ boiling	V	This is the end-result of proper diffuser selection and placement; and also correct air pressure
iii)	Maintenance of diffusers	Select a few diffusers (typically the diffuser in the most remote corner) and execute a mock repair cycle and check for the following: a) Easy to isolate from the rest of the system b) Easy to retrieve the chosen element c) Easy to dismantle the element without disturbing the other plumbing d) Easy to clean the element e) Easy to lower it back at the exact spot		

D-4 RAW SEWAGE LIFT PUMPS TANK

<i>Sl No.</i> (1)	<i>Check</i> (2)	<i>Acceptance Criteria</i> (3)	<i>Method</i> (4)	<i>Rationale</i> (5)
i)	Easily accessible	Simulate a repair cycle on the pump that is more difficult to access and check the following: a) Easy to isolate from the rest of the system b) Easy to dismantle c) The rest of the plumbing is not disturbed d) Easy to carry it outside its area e) Easy to place it back and assemble it	V	The STP should allow easy maintenance of pumps without significant interruption of its process

D-5 AERATION TANK

<i>Sl No.</i> (1)	<i>Check</i> (2)	<i>Acceptance Criteria</i> (3)	<i>Method</i> (4)	<i>Rationale</i> (5)
i)	Baffle wall function	a) The sewage is let into the baffle zone – No splash or overflow b) There is no bubble-free dead zone adjacent to the baffle wall on the tank	V	These signs indicate wrong dimensions of the baffle wall
ii)	Diffuser function	a) Bubbles rise uniformly across the surface b) No dead zone (especially near walls and corners) c) No large bubbles bursting through	V	To get optimum results, you may need to adjust the placement of diffusers and/or air pressure in individual diffusers

<i>Sl No.</i>	<i>Check</i>	<i>Acceptance Criteria</i>	<i>Method</i>	<i>Rationale</i>
(1)	(2)	(3)	(4)	(5)
iii)	Maintenance of diffusers	Simulate a service cycle on sample diffusers (select the most remote elements) and check for the following: a) Easy to isolate from the rest of the system b) Easy to retrieve the chosen element c) Easy to dismantle the element without disturbing the other plumbing. d) Easy to clean the element e) Easy to lower it back at the exact spot	T	Maintenance of diffusers should not disrupt the STP functioning
iv)	Membrane type diffuser	Pull out and check if membranes are in good condition	V	—
v)	Split aeration tank	Easy to isolate and empty each tank for repairs a) Cut off compressed air (Check safety function) b) Equal flow of sewage and recycle sludge to each compartment	V	—
vi)	Biomass in Aeration tank	a) Healthy brown biomass b) Check MLSS level in aeration tank	V T	— —

D-6 SECONDARY CLARIFIER TANK

<i>Sl No.</i>	<i>Check</i>	<i>Acceptance Criteria</i>	<i>Method</i>	<i>Rationale</i>
(1)	(2)	(3)	(4)	(5)
i)	Settling of sludge	a) Sludge settles without vortex b) No sludge drawn up near the weir c) No significant sludge trace in the launders d) No clumps/ balls of rising sludge	V	—
ii)	Fine mesh basket at outlet	Easy to service the mesh, for which check the following: a) Easy to remove b) Easy to clean c) Easy to fit it in place	T	—
iii)	Bridge	a) Bridge allows safe travel up to motor and gear box b) The safety railing has closely spaced balusters to prevent accidental fall from under the railing	T	—
iv)	Maintenance of motor and gearbox	Simulate a repair cycle for the motor and gearbox a) Safe access to the motor and gearbox b) Allows safe removal of motor and gearbox c) Allows safe carrying of parts out of tank d) Allows safe re-fitting of parts e) Check rotational speed of rake	T M	If the motor and gear box cannot be made functional within 30 min, the bacteria may start dying

<i>Sl No.</i>	<i>Check</i>	<i>Acceptance Criteria</i>	<i>Method</i>	<i>Rationale</i>
(1)	(2)	(3)	(4)	(5)
v)	Weir level	Check for uniform overflow of water over the entire length of the weir(s)	T	—

D-7 SLUDGE RECIRCULATION PUMPS — AIRLIFT

<i>Sl No.</i>	<i>Check</i>	<i>Acceptance Criteria</i>	<i>Method</i>	<i>Rationale</i>
(1)	(2)	(3)	(4)	(5)
i)	Air lift	Check if recirculation sludge flow is roughly between 60 and 100 percent of sewage inflow	V	—

D-8 SLUDGE RECIRCULATION PUMPS — ELECTRIC

<i>Sl No.</i>	<i>Check</i>	<i>Acceptance Criteria</i>	<i>Method</i>	<i>Rationale</i>
(1)	(2)	(3)	(4)	(5)
i)	Air lift	Check if recirculation sludge flow is roughly between 60 and 100 percent of sewage inflow	V	—
NOTE — Based on the STP design, select the previous table (for an airlift pump) or this table (for electric pumps used in direct-suction or buffer sump variations).				

D-9 SLUDGE RECIRCULATION SYSTEM — WITH A BUFFER SUMP

<i>Sl No.</i>	<i>Check</i>	<i>Acceptance Criteria</i>	<i>Method</i>	<i>Rationale</i>
(1)	(2)	(3)	(4)	(5)
i)	Aeration and mixing in sludge sump	a) Bubbles rise across the entire surface (no dead zone in any area, especially edges and corners) b) There is no odour	V	This means the system does not pose a threat to the bacteria
ii)	Maintenance of pump	Simulate a repair cycle (select the pump that is more difficult to access) and check for the following: a) Easy to cut off from the rest of the system b) Easy to remove c) Easy to carry outside STP d) Easy to assemble back. e) Check if recirculation sludge flow is roughly between 60 and 100 percent of sewage inflow		
			T	Although availability of a standby drastically reduces the risk, it should be easy (and fast) to repair a defective pump

D-10 CLARIFIED WATER TANK

<i>Sl No.</i>	<i>Check</i>	<i>Acceptance Criteria</i>	<i>Method</i>	<i>Rationale</i>
(1)	(2)	(3)	(4)	(5)
i)	Aeration and mixing	a) Bubbles rise across the entire surface (no dead zone in any area, especially edges and corners) b) There is no odour c) No accumulation of solids in the tank	V	—

D-11 FILTER FEED PUMPS

<i>Sl No.</i>	<i>Check</i>	<i>Acceptance Criteria</i>	<i>Method</i>	<i>Rationale</i>
(1)	(2)	(3)	(4)	(5)
i)	Maintenance of pump	Simulate a repair cycle (select the pump that is more difficult to access) and check the following: a) Easy to cut off from the rest of the system b) Easy to remove c) Easy to carry outside STP d) Easy to assemble back	T	—

D-12 BACKWASH PUMPS

<i>Sl No.</i>	<i>Check</i>	<i>Acceptance Criteria</i>	<i>Method</i>	<i>Rationale</i>
(1)	(2)	(3)	(4)	(5)
i)	Maintenance of pump	Simulate a repair cycle (select the pump that is more difficult to access) and check the following: a) Easy to cut off from the rest of the system b) Easy to remove c) Easy to carry outside STP d) Easy to assemble back	T	—

NOTE — This table is applicable only when the design uses a separate set of pumps for backwash (not by reversing the flow of the filter-feed pumps)

D-13 PRESSURE SAND FILTER

<i>Sl No.</i>	<i>Check</i>	<i>Acceptance Criteria</i>	<i>Method</i>	<i>Rationale</i>
(1)	(2)	(3)	(4)	(5)
i)	Filter operation	Filter is able to handle design flow of water without excessive pressure drop	T	—
ii)	Filter Backwash	Backwash filter for 5-10 min and check if initially lot of solids come out, gradually becoming clearer and finally clear water is observed	T	—

D-14 ACTIVATED CARBON FILTER

<i>Sl No.</i>	<i>Check</i>	<i>Acceptance Criteria</i>	<i>Method</i>	<i>Rationale</i>
(1)	(2)	(3)	(4)	(5)
i)	Filter operation	Get analysis reports and compare quality at inlet to filter and outlet of filter	T	—
ii)	Filter Backwash	Backwash filter for 5 min and check if initially lot of solids come out, gradually becoming clearer and finally clear water is observed	T	—

D-15 DISINFECTION SYSTEM

<i>Sl No.</i>	<i>Check</i>	<i>Acceptance Criteria</i>	<i>Method</i>	<i>Rationale</i>
(1)	(2)	(3)	(4)	(5)
i)	Hypo dosing	Check residual chlorine level with test kit It shall be more than 1 ppm after 30 min of standing	T	—

D-16 SLUDGE-HANDLING SYSTEM

<i>Sl No.</i>	<i>Check</i>	<i>Acceptance Criteria</i>	<i>Method</i>	<i>Rationale</i>
(1)	(2)	(3)	(4)	(5)
i)	Filter press operation	Run an entire sludge dewatering cycle of one batch, and check quantity (weight) of sludge cake produced	T	—

D-17 AIR BLOWERS

<i>Sl No.</i>	<i>Check</i>	<i>Acceptance Criteria</i>	<i>Method</i>	<i>Rationale</i>
(1)	(2)	(3)	(4)	(5)
i)	Noise	Measure the noise. Results more than 80 dB(A) indicate corrective measures are needed	T	—
ii)	Capacity	Check if air in sufficient quantity is delivered to all connected tanks simultaneously, as visual indications for each tank as described above	T	—

ANNEX E

(Clause 13.3.7)

GUIDELINES FOR MAINTENANCE OF ELECTRICAL EQUIPMENT

E-1 In case of electrical appliances, manufacturer’s instructions for the usage and maintenance of the equipment should be strictly followed.

E-2 The detailed/working drawings of all the components of electrical installations should always be available with the maintenance unit. Following records should be available:

- a) Manufacturer’s name;
- b) Name plate of the equipment and its salient features such as capacity, rating, etc;
- c) Manufacturer’s recommendations regarding availability/usage of spare parts;
- d) Manufacturer’s recommendations for periodical maintenance and post fault maintenance;
- e) Details of the maintenance operations performed in the past; and

f) History card of equipment shall be maintained and made available when required.

E-3 Care should be taken while selecting replacement parts. The spare parts should be correct and suitable, preferably as recommended by the manufacturer concerned. During the placement of order for the supply of spare parts, nameplate particulars and serial number should be quoted.

E-4 The space where the equipment is kept should be clean and properly ventilated. Equipment should not be disturbed needlessly. Before cleaning, the equipment should be made dead. For internal cleaning a section cleaner should be used.

E-5 Covers and doors should not be left open unnecessarily during maintenance. Afterwards they should be promptly and correctly closed and locked.

E-6 Before removing the covers and connections, all covers and cable terminations should be marked to ensure correct replacements. Disturbed connections

and temporary connections should be marked to facilitate reconnection. Temporary connections and markings should be removed before the installation is put to use.

E-7 Those connections which have not been disturbed should also be checked for soundness and overheating.

E-8 All insulations should be regularly checked. Solid insulations should be checked for cracks and other defects. Fibrous and organic insulations should be checked for sign of blistering, delamination and mechanical damage. For insulating oils the interval between tests should be carried out as per the recommendations of the manufacturer and keeping the adverse environmental conditions in mind or at least once in an year.

E-9 It should be ensured that the earthing connections are sound and all contact screws are tight.

E-10 During the examination of interlocks it is necessary to take precautions to prevent danger to plant or persons in the event of malfunction or inadvertent operation. A person responsible for checking and maintaining any interlock system should have thorough knowledge of the extent, nature and function of the interlock.

E-11 If the equipment is ventilated then it should be ensured that the airflow is smooth and not restricted. If filters are provided, they should be cleaned or replaced as necessary.

E-12 The standby system for tripping and closing supplies should always be kept in good order. Indicators and alarms should be maintained in time with the manufacturer's instructions.

E-13 Tools, spares and instruments should be stored near to the installation. These should be regularly checked against an inventory.

E-14 Before the start of maintenance of the circuit switches it should be ensured that all incoming and outgoing main auxiliary circuits are dead and remain so during the maintenance. Over heating of the circuit switches is the root cause for faults. Overheating may be caused by inadequate ventilation, overloading,

loose connection, insufficient contact force and misalignment.

E-15 Some circuit breakers are not intended to be maintained, such as miniature circuit breakers (MCBs). Such items should not be dismantled for maintenance. These should be renewed if not found functional.

E-16 For the maintenance of fuses periodical inspection should be done for correct rating, security, overheating and correct location/orientation. Element of renewable fuses should be renewed when the deterioration is apparent. The availability and correct replacement of fuse links should be ensured.

E-17 If a fuse link of certain rating has failed and is replaced, then all fuse links of same rating apparently subjected to the fault should be destroyed and replaced by new fuse links.

E-18 In order to be reasonably sure that circuit breaker is capable of operation when required, these should be tripped and reclosed at regular intervals. Tripping should be proved manually and where possible electrically *via* the protective relay contacts. The leakage of oil, sign of corrosion, and any unusual smell which may indicate over-heating should be detected through inspections.

E-19 Timing devices are mostly designed for specialist maintenance. These should not be dismantled for maintenance or overhaul purposes unless specifically recommended by the manufacturers'. Actual timing periods should be verified with set values and application requirements.

E-20 In case of cable boxes and terminations, security of mounting and earthing should be examined. Exposed tails should be inspected for good conditions of insulation and freedom from moisture.

E-21 Battery cells should be inspected for shedding of active material, sedimentation and buckling of plates. Level of electrolyte should be regularly checked and the level should be corrected with distilled water.

ANNEX F
(Clause 14.6)

FORMAT FOR PREVENTIVE MAINTENANCE PROFILE OF LIFTS

		Maintenance S1 (See Note)					Maintenance S2 (See Note)					Maintenance S3 (See Note)				
		A	B	C	D	E	A	B	C	D	E	A	B	C	D	E
Components																
Tasks																
0	Contact customer															
1	Car interior calls, indicators, fixings	x	x		x		x	x		x		x	x		x	
2	Car lighting and diffuser	x	x		x		x	x		x		x				
3	Car door safety devices		x	x				x	x				x	x		
4	Levelling accuracy/jerk free/noise	x		x				x		x			x			
5	Landing operating panels, optical, acoustical fixings	x	x		x		x	x		x		x			x	
6	Controller: protection cover, lock, documentation	x	x	x	x		x	x	x	x		x			x	
7	Date check, error-log, LEDs check	x	x	x			x	x	x							
8	RAM/Trip counter/long-term tasks	x	x	x	x	x	x	x	x	x	x					
9	Manual/automatic passenger rescue device	x	x				x	x				x				
10	Alarm, communication systems two way with main power 'ON'												x			
11	Emergency car communicate and lighting systems	x	x				x	x				x	x			
12	Connections, contactors, relays, electrical protections	x	x		x		x	x		x		x				
13	Floor level indicate, LED control	x	x				x	x				x				
14	Control booklet of maintenance visits and break downs according to local regulation	x					x					x				
15	Car relevelling/blocking/speed control devices		x					x					x			
16	Final limit switches		x					x								
17	Hoistway lightning		x		x				x				x			
18	Remote control devices for speed governor and machine brake		x					x								
19	Safety gear						x	x	x	x	x					
20	Maintenance operating device/short head room device		x					x					x			
21	Car top/maintenance platform, car blocking device	x			x		x	x		x						
22	Inspection: top of hoistway travel limit		x					x								
23	Motor: frame, fan, bearing Lubrication and level, fixings, pulleys	x			x	x	x			x	x					
24	Gear: tachometer, backlash, thrust bearing, oil level	x		x	x	x	x		x	x	x	x				
25	Machine brake: mechanical and electrical, coupling rubbers, brake contact		x	x	x	x		x	x	x	x	x				

		<i>Maintenance S1</i> (See Note)					<i>Maintenance S2</i> (See Note)					<i>Maintenance S3</i> (See Note)							
		A	B	C	D	E	A	B	C	D	E	A	B	C	D	E			
		Components																	
Tasks																			
26	Frequency converter	x			x	x									x				
27	Speed governor	x			x	x	x		x	x					x				
28	Car fixings	x		x															
29	Car suspension fixations and slack-rope contact	x	x		x	x			x						x				
30	Car guide shoes and lubricators/rollers	x		x	x	x	x					x	x	x					
31	Hoistway doors mechanical and electrical	x	x	x	x	x	x	x	x	x	x	x	x	x	x	x			x
32	Hoistway information and connections	x		x	x			x			x	x							
33	Guide rail fixations	x		x															
34	Counter weight: guide shoes and lubricators, frame, suspension/divertor pulley fixation	x		x	x	x	x				x	x	x						
35	Counter weight: weight fixation/anti-jump/anti-twist buffer plate/compensation	x			x			x				x			x				
36	Speed governor rope	x													x				
37	Suspension ropes/STM condition and tension	x		x				x							x				
38	Door drive mechanical and electrical	x	x	x	x	x	x	x	x	x	x	x	x						x
39	Car door safety contact		x	x	x				x	x	x					x			
40	Car door coupling to landing doors	x	x	x				x	x	x									
41	Hoistway pit safety set		x		x				x			x							
42	Hoistway/hoistway pit/oil collectors	x			x			x				x							x
43	Speed governor rope tensioning pulley and contact		x	x	x	x			x	x	x	x	x	x					
44	Buffers	x	x		x	x	x								x				
45	Safety gear/buffer plate/guide shoes							x	x	x	x	x	x						
46	Suspension ropes/STM position, pulleys and retainers	x			x	x					x				x				
47	TSDs topper plate fixation and safety contact	x						x				x	x	x					
48	Compensating chain/rope and pulley	x		x	x	x			x			x			x				
49	Travelling cable and attachments	x							x						x				
50	Counterweight distance to buffer when car at top	x		x					x			x				x			
51	Load measuring device		x	x	x				x	x	x								
52	Fireman’s control, special options, automatic evaluation	x	x						x							x			
53	Feedback to customer, if any	x							x						x				

NOTE — A = Visual check, B = Function check, C = Measurement, D = Cleaning, and E = Lubrication.

S1 and S2 : Inspection to be carried out once in 6 months; and

S3 : Inspection to be carried out once in 3 months.

ANNEX G
(Clauses 14.7.1 and 14.7.2)

TYPICAL CHECKLISTS FOR MAINTENANCE OF LIFTS AND ESCALATORS

G-1 TYPICAL CHECKLIST FOR DAILY MAINTENANCE OF LIFTS

DAILY CHECKLIST FOR LIFTS:														
Site Name:									Month:		Date:			
<i>Sl No.</i>	<i>Toner/ Lift No.</i>	<i>Emergency Light and Car Light</i>	<i>Hooter/ Alarm</i>	<i>Intercom</i>	<i>Door Sensor</i>	<i>All Calls and Indications</i>	<i>Floor Level</i>	<i>Any Noise Vibration</i>	<i>Music/ Floor Voice Announcement System</i>	<i>Car Fans/ Blowers</i>	<i>Car Sill and Landing Door Sills</i>	<i>CCTV</i>	<i>General Clearing</i>	<i>Remarks</i>
i)														
ii)														
iii)														
iv)														
v)														
vi)														
vii)														
viii)														

G-2 TYPICAL CHECKLIST FOR MONTHLY MAINTENANCE OF LIFTS

MONTHLY CHECKLIST FOR LIFTS:																
<i>Site:</i>		<i>Location:</i>	<i>Lift No.:</i>	<i>Jan</i>	<i>Feb</i>	<i>Mar</i>	<i>Apr</i>	<i>May</i>	<i>Jun</i>	<i>Jul</i>	<i>Aug</i>	<i>Sep</i>	<i>Oct</i>	<i>Nov</i>	<i>Dec</i>	
<i>Sl No.</i>	<i>Activity to be Carried Out</i>	<i>Status of Activity Carried Out</i>	<i>Details of the Parts Replaced, if Any</i>													<i>Remarks</i>
i)	All daily checks															
ii)	Check the oil level in machine gear box															
iii)	Inspection of ropes and its tension															
iv)	Lubrication of guide rails															
v)	Check bearing/ bush noise in machine room															
vi)	Door sensors/ alignment															
vii)	Check of hall/car call buttons and signal															
viii)	Governor checks															
ix)	Landing doors/car gate checks															
x)	ARD and controller checks															
xi)	Pit equipment checks															
xii)	Fireman operation															
xiii)	Hoistway equipment checks															
xiv)	Car signages and aesthetics															
Signature OBM:																
Signature Shift Engineer:																
Signature Facility Manager:																

G-3 TYPICAL CHECKLIST FOR DAILY MAINTENANCE OF ESCALATORS

SITE NAME:			DAILY CHECKLIST FOR ESCALATORS:										Date:	
<i>Sl No.</i>	<i>ESC No.</i>	<i>Location</i>	<i>Escalators Light (Comb Light, Handrail Light and, Traffic Light, Step Light)</i>	<i>Skirting/ Skirt Light and Skirt Brush</i>	<i>Balust- rade</i>	<i>Floor Plates Up/ Down</i>	<i>Steps</i>	<i>Auto/ Manual Sensors</i>	<i>Decking</i>	<i>Comb Plate</i>	<i>Handrail</i>	<i>Noise, if any</i>	<i>Remarks</i>	
Signature OEM:														
Signature Shift Engineer:														
Signature Building Manager:														

G-4 TYPICAL CHECKLIST FOR MONTHLY MAINTENANCE OF ESCALATORS

MONTHLY CHECKLIST FOR ESCALATORS:													Date:			
Site:	Locations:	Esc. No.:		Jan	Feb	Mar	Apr	May	Jun	Jul	Aug	Sep	Oct	Nov	Dec	Remarks
Sl No.	Activity to be Carried Out	Status of Activity Carried Out	Details of the Parts Replaced, if any													
i)	All daily checks															
ii)	Check the oil level in machine gear box															
iii)	Chain tension checks															
iv)	Lubrication of all moving parts															
v)	Check bearing/ bush noise in machine															
vi)	Roller checks															
vii)	Floor plates sensors															
viii)	Hand rail speed monitor															
ix)	Step missing sensor															
x)	Broken steps chain monitor															
xi)	Broken hand rail monitor															
xii)	Over speed monitor															
xiii)	Skirt missing sensor															
xiv)	Anti-static brush															
xv)	Emergency switch Up/Down															
xvi)	Controller checks															
xvii)	Signages and aesthetics															
	Signature OEM															
	Signature Shift Engineer:															
	Signature Building Manager:															

ANNEX H
(Clause 18.5.6)

TYPICAL CHECK LIST FOR LANDSCAPE AREAS

H-1 A typical checklist for landscape areas is given below:

- a) Mow and edge lawns, if needed.
- b) Prune back any shrubs overhanging kerbs or sidewalks.
- c) Prune back any groundcover overhanging kerbs or sidewalks.
- d) Remove litter and leaves from plants, planters, and parking lots.
- e) Remove any broken or fallen branches from trees. Remove sucker growth from tree trunks.
- f) Remove any weeds larger than 50 mm high or wide from planters. Weeds 50 mm and larger shall be removed, not just killed.
- g) Replace bark mulch which has been knocked or washed out of planters. Smooth mulch layer, if it has been disturbed.
- h) Replace decorative rock which has been knocked or washed out of planters. Smooth decorative rock surface, if it has been disturbed.
- j) Check plants for signs of stress or disease. Replace any plants that meet conditions for replacement. Request authorization to replace other dead or missing plants (see Note 1).
- k) Sweep or blow clean all walkways, curbs, and gutters.
- m) Treat for any signs of disease or pest infestation.
- n) Complete any items required on the monthly checklist.
- p) Hand water any plants that are dry and stressed.
- q) Check the irrigation system. Make emergency repairs as needed or request authorization to make major repairs (see Note 2).
- r) Adjust the irrigation controllers for current water needs of plants.

NOTES

- 1 Request authorization to make replacements within one week of the damage becoming evident.
- 2 Request authorization for repairs within one week of the damage becoming evident.

ANNEX J
(Clause 19.4.4)

TYPICAL TEMPLATE FOR HOUSEKEEPING OF HOTELS

GENERAL CLEANING							
Month :							
<i>Sl No.</i>	<i>Indicative Scope of Work</i>	<i>Time-lines</i>	<i>Reference Document</i>	<i>Impact</i>	<i>Incident Tracker</i>	<i>Non-Conformance</i>	<i>Total Conformance</i>
i)	General cleaning		Supervisor checklist	Medium			
ii)	Supply of people related, housekeeping equipment, housekeeping chemical		Deployment sheet/attendance register	Medium			
<i>Daily activities to be completed with minimal disruptions during office hours</i>							
iii)	Sweeping floors/wet mopping	Daily twice		Medium			

iv)	Washroom cleaning	Daily once		High			
v)	Cleaning of dustbins	Daily twice		High			
vi)	Cleaning lift, cabin, floor and carpet	Daily once		High			
<i>Repetitive daily activities (Consumables inventory)</i>							
vii)	Clean all unwanted materials collected from all floors to the main dustbin after security verification	As and when required	Supervisor checklist	Medium			
viii)	Dusting the window glass	Once	Supervisor checklist	Medium			
ix)	Clean the staircase and ensure the area is mopped and railings cleaned	Once and as and when required	Supervisor checklist	Medium			
<i>Weekly activities</i>							
x)	Wet mopping of emergency stair case of all floors	Once a week	Weekend checklist	Medium			
xi)	Deep cleaning of plant rooms			Medium			
xii)	Wiping of plumbing in STP, HT/LT room and pump room			Medium			
xiii)	Cleaning of storage area			Medium			
xiv)	Terrace area			Medium			
<i>Fortnightly activities</i>							
xv)	Clean the cob-webs at all floors	Once a fortnight	Weekend checklist	Medium			
xvi)	Polishing of lift cabin with relevant chemicals to maintain the shine			Medium			
xvii)	Water cleaning of the parking area using high pressure jet			Medium			

LIST OF STANDARDS

The following list records those standards which are acceptable as 'good practice' and 'accepted standards' in the fulfillment of the requirements of the Code. The latest version of a standard shall be adopted at the time of enforcement of the Code. The standards listed may be used by the Authority for conformance with the requirements of the referred clauses in the Code.

In the following list, the number appearing in the first column within parentheses indicates the number of the reference in this Part.

<i>IS No.</i>	<i>Title</i>	<i>IS No.</i>	<i>Title</i>
		(6)	2190 : 2010
			Selection, installation and maintenance of first-aid fire extinguishers — Code of practice (<i>fourth revision</i>)
		(7)	2189 : 2008
			Selection, installation and maintenance of automatic fire detection and alarm system — Code of practice (<i>fourth revision</i>)
		(8)	15301 : 2003
(1)	15183 (Part 2) : 2002		Installation and maintenance of fire fighting pumps — Code of practice
	Guidelines for maintenance management of buildings: Part 2 Finance	(9)	13039 : 2014
(2)	15183 (Part 3) : 2002		External hydrant systems — Provision and maintenance — Code of practice (<i>first revision</i>)
	Guidelines for maintenance management of buildings: Part 3 Labour	(10)	3844 : 1989
(3)	11208 : 1985		Code of practice for installation and maintenance of internal fire hydrants and hose reels on premises (<i>first revision</i>)
	Guidelines for registration of plumbers	(11)	15105 : 2002
(4)	13182 : 1991		Design and installation of fixed automatic sprinkler fire extinguishing systems — Code of practice
	Waterproofing and damp-proofing of wet areas in building — Recommendations		
(5)	2064 : 1993		
	Code of practice for selection, installation and maintenance of sanitary appliances (<i>second revision</i>)		



BUREAU OF INDIAN STANDARDS

Manak Bhavan, 9 Bahadur Shah Zafar Marg, New Delhi-110 002

www.bis.gov.in

AMENDMENT NO. 1 MARCH 2021**TO****SP 7 : 2016 NATIONAL BUILDING CODE OF INDIA 2016**

This amendment amends the provisions of Part 4 ‘Fire and Life Safety’ of the Code, as follows:

(Page 11, clause **2.43.9**) — Insert the following definition at the end:

‘2.43.10 Link Load — The number of passengers travelling between two stations on board a train or trains during peak headway.’

(Page 13, clause **3.1.1.2**, line 3) — Substitute ‘**3.1.11**’ for ‘**3.1.12**’.

(Page 16, clause **3.1.8**, para 5, line 1) — Delete the words ‘and fire load density’.

[Page 34, clause **4.4.2.4.3.2** (f), line 6] — Substitute ‘90 mm’ for ‘115 mm’.

[Page 34, clause **4.4.2.4.3.2** (h) (12)] — Substitute the following for the existing:

‘12) Scissors type staircases (of type where intermingling of persons in the landing is possible or of type where both stairs use the common air space) shall not be treated as part of exit.’

(Page 51, Table 7, Note 16) — Insert the following at the end:

‘For C-1 occupancy, see also **6.3.2(g)(4)**’.

(Page 53, clause **5.1.2.1**, para 7, line 1) — Substitute ‘The covering slab and its supporting wall/supporting system’ for ‘The covering slab’.

(Page 64, clause **6.4.4**) — Substitute the following for the existing:

‘6.4.4 Fire Protection and Firefighting System for Metro Stations (D-7 Occupancy)

Fire and life safety requirements for metro stations and metro trainways shall be in accordance with Annex J and Annex K, respectively. In case of any ambiguity with respect to provisions in Part 4 or any other Part of the Code, the respective provisions given in Annexes J and K shall be applicable.’

(Page 94, reference under heading Annex H) — Substitute ‘Clauses 6.4.2.2(e) and 6.8.1.5’ for ‘Clauses 6.4.2.2 and 6.8.1.5’.

[Page 97, clause **J-4.1(e)**] — Substitute the following for the existing:

‘e) Peak hour load shall be converted to peak minute load by dividing by 60 and multiplying further by a system surge factor varying from 1.3 to 1.5, as defined by the transit system authority. Surge factor may require to be further enhanced where increased footfalls are anticipated, like stations catering to sports complex transit oriented development, and stations serving two or more lines.

NOTE — Surge factors shall be based on actual calculations by transit system authority and in no case it shall be less than 1.3.’

[Page 97, clause **J-4.1(f)(1)**] — Substitute the following for the existing:

‘1) *Train on fire* — It is assumed that a train loaded to crush capacity/link load as may be decided by the transit system authority, travelling in peak direction at peak hour has caught fire, and as per the operating procedure it is brought to the next station, whereupon it shall require to be evacuated.’

Amendment No. 1 to SP 7 : 2016

[Page 97, clause J-4.1(g), line 6] — Substitute ‘train load/link load’ for ‘train load’.

[Page 97, clause J-4.1(j)] — Substitute the following the existing:

‘j) Segregation with non-transit occupancy:

Non-transit (and incidental) occupancies of area up to 250 m² (total area of all floors), shall be permitted to be accommodated within the station building. Occupant load of areas under non-transit occupancies shall be in accordance with Table 3.’

(Page 100, clause J-6.4, line 4) — Substitute ‘10 m²’ for ‘6 m²’.

[Page 101, Table 27, Sl No. (i)] — Substitute the following for the existing:

‘i) Auxiliary substation, electrical UPS/battery room 2h 2h 2h 2h’

[Page 101, Table 27, Sl No. (iv), col. no. 2] — Delete the words ‘cash and ticket supervisor room,’ and ‘toilets,’.

[Pages 114 and 115, List of standards under Sl. No. (17)] — Delete the following entries and their corresponding titles:

‘2878 : 2004’

‘13385 : 1992’

‘13386 : 1992’

[Page 115, List of standards under Sl. No. (17)] — Insert the following standard at the end:

‘16018 : 2012 Wheeled fire extinguisher — Performance and construction — Specification’

[Page 116, List of standards under Sl. No. (26)] — Delete ‘13039 : 1991’ and its corresponding title.